

Reflections on the Integration of Social Justice Concepts into an Introductory Control Systems Course (Work in Progress)

Dr. Kathryn Johnson, Colorado School of Mines

Kathryn Johnson is an Associate Professor at the Colorado School of Mines in the Department of Electrical Engineering and Computer Science and is jointly appointed at the National Renewable Energy Laboratory's National Wind Technology Center. In the fall 2011, she was a visiting researcher at Aalborg University in Denmark, where she collaborated on wind turbine control research and experienced Aalborg's Problem-Based Learning method. She has researched wind turbine control systems since 2002, with numerous projects related to reducing turbine loads and increasing energy capture. She has applied experiential learning techniques in several wind energy and control systems classes and began engineering education research related to social justice in control systems engineering in fall 2014.

Dr. Jon A. Leydens, Colorado School of Mines

Jon A. Leydens is an associate professor in the Division of Liberal Arts and International Studies at the Colorado School of Mines, USA, where he has been since 1997. Research and teaching interests include communication, social justice, and engineering education. Dr. Leydens is co-author of *Engineering and Sustainable Community Development* (Morgan and Claypool, 2010) and editor of *Sociotechnical Communication in Engineering* (Routledge, 2014). Dr. Leydens won the James F. Lufkin Award for the best conference paper—on the intersections between professional communication research and social justice—at the 2012 International Professional Communication Conference. In 2015, he won the Ronald S. Blicq Award for Distinction in Technical Communication Education from the Professional Communication Society of the Institute for Electrical and Electronic Engineers (IEEE). His current research focuses on rendering visible and integrating the social justice dimensions inherent in three components of the engineering curriculum—in engineering sciences, engineering design, and humanities and social science courses. That research, conducted with co-author Juan C. Lucena, will culminate in *Engineering Justice: Transforming Engineering Education and Practice* (Wiley-IEEE Press, 2017).

Dr. Barbara M. Moskal, Colorado School of Mines

Barbara Moskal is a professor of Applied Mathematics and Statistics and the Director of the Trefny Institute for Educational Innovation at the Colorado School of Mines. She is also a Senior Associate Editor for the *Journal of Engineering Education*.

Reflections on the Integration of Social Justice Concepts into an Introductory Control Systems Course (Work in Progress)

Introduction

Real engineering problems are solved not in a vacuum but in social contexts, so engineering practice demands sociotechnical thinking—learning to define and solve problems not in exclusive technical terms nor just in social terms but in both. Since social dimensions shape and are shaped by technical dimensions¹, engineers need to understand sociotechnical problem defining and solving processes². Yet students in technical engineering courses often focus exclusively on the technical, and in their Humanities and Social Science courses they often focus exclusively on the social; meetings of the technical and the social may occur in engineering design courses, but often superficially. Hence, a need to provide practice in sociotechnical thinking pervades the entire engineering curriculum. The focus here is on an engineering science (ES) course.

During the Fall 2014 and Fall 2015 semesters, our research team integrated social justice concepts into the ES core course “Introduction to Feedback Control Systems” (IFCS) at our public university, the Colorado School of Mines (CSM). Our motivation was to introduce students to a missing or underrepresented element of the curriculum at CSM, and to do so in such a manner that challenges the “sacred cow” notion of the ES core curriculum^{2,3}, reinforcing the high value of social justice to engineering as opposed to placing it in a course with lower perceived value. We have previously reported on results from this integration^{4,5}; this paper adds additional value to engineering educators interested in similar integrations by reflecting primarily on the instructor’s experiences and providing insights into the implementation process in this work-in-progress paper, inspired by the field of collective autoethnography⁶. The perspective taken on this paper is that of the instructor, reflecting on two semesters of implementing social justice concepts into the ES course.

A key inspiration for this paper is the reflective account provided by Huff⁷. Based on this work, it is clear that faculty need resources and examples as they embed social justice or other educational innovations into the engineering curriculum. Matusovich and collaborators⁸ have further argued that faculty motivation provides both an opportunity and a barrier to improving engineering education. We hope to provide a concrete example that prompts dialogue among faculty regarding the process of curriculum innovation.

The three faculty members on our research team worked collaboratively and with other faculty and students to integrate social justice concepts; the team also analyzed survey, focus group, and interview data. However, as would be expected, day-to-day experiences were the primary responsibility of the instructor. Student responses from the Fall 2014 iteration, discussed in reference⁴, influenced significant revisions to the Fall 2015 iteration. In this paper, we track our activities and critical reflections during and across both iterations. We illustrate numerous challenges experienced by the instructor, including student pushback and the struggle to balance content. Opportunities also surfaced, including insightful and eager conversations between students and faculty and student insights on learning control systems via a sociotechnical rather than just technical approach. From the perspective of the course professor, teaching this course

was a form of rewarding professional development. For the students, it was an opportunity to learn control systems content, to render visible the (previously obscure) social justice dimensions of that content, and to foster “real world” understanding of control systems.

Context

Early in our research, we framed social justice as an important missing element in engineering education because of its importance within the reasonably well-accepted goal of sustainability. Sustainability requires three cornerstones, sometimes called the Three P’s or Three E’s: people/ethics, profit/economy and planet/environment⁹, yet the full triad is frequently left out of the engineering curriculum. The first of these concepts, which addresses the human and ethical elements, probably receives the least instructional attention when compared to the other two. By not exposing students to the social dimensions inherent in engineering, we risk the development of engineering professionals who do not consider the needs of the individuals, communities, or societies impacted by engineering designs.

We began the research without a formal definition of social justice, but more recently have shared the following definition¹⁰ with our students:

“...we define SJ [social justice] as engineering practices that strive to **enhance human capabilities (goal) through an equitable distribution of opportunities and resources** while **reducing imposed risks and harms (means)** among agentic citizens of a specific community.” (p. 4)

Stemming from this definition, we have introduced students to six elements of social justice for consideration in engineering problem solving and definition, as shown in Table 1. In some ways, IFCS, a rigorously mathematical course, seems a difficult choice for social justice integration. However, students in the course learn to design a feedback controller to achieve a certain goal, and elements such as problem definition, design constraints and specifications, and the selection of the system to be controlled can all lend themselves to social justice considerations as they would in an engineering design course. The class is centered on the classical feedback loop shown in Figure 1; sociotechnical thinking can dramatically influence the definition of the system to be controlled and the reference signal, which in turn impacts the remainder of the feedback system.

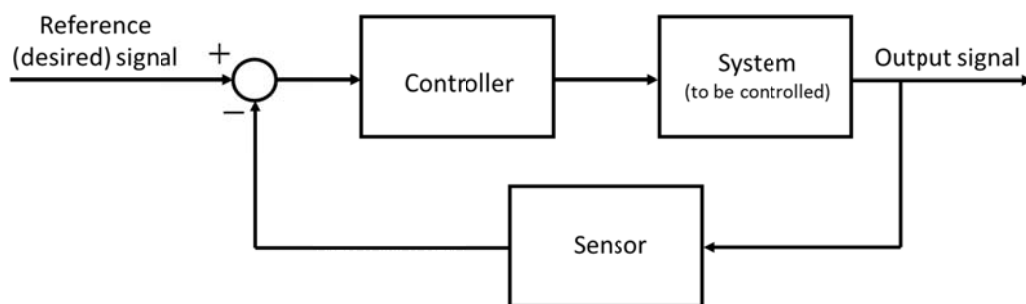

Figure 1: Classical feedback control loop showing a physical system to be controlled (“System”), its physical output, the desired plant output (“Reference (desired) signal”), and the controller that achieves the desired objectives.

Since misconceptions about the meaning of social justice are commonplace and since the term can be too abstractly, the instructor provided students with the above definition and a contextualized problem involving the design of a system that controls the height of the water in a water tank. The third column of Table 1 gives examples of social justice questions related to the tank’s water-level control design; professors can ask such questions to engage students to consider the sociotechnical elements of feedback control design and to model such questions so students can later conduct such inquiries into other feedback control systems themselves.

Table 1: Social justice criteria, definitions, and examples

Criteria	Definition	CSM Example
1. Listening contextually	...to diverse users and actors so the ways in which the social context shapes (and is shaped by) the technical becomes visible. Listening to discover more about criteria 2-6.	In the contextualized water tank problem, students realized that to solve the problem well, they needed to listen to the social context by asking locals questions: How scarce is water? How much of locals’ income is their water bill?
2. Identifying structural conditions	...so social structures (legal, historical, economic, etc.) that serve as real or potential barriers and/or opportunities to users, key actors, or engineers become visible.	Who controls water supplies? Do water monopolies exist? What other water source options do locals have, in any? Are water resources privately owned? If so, what percentage of water? What other water access issues emerge?
3. Acknowledging political agency/ mobilizing power	...so engineers can identify forms of political agency (of users, key actors, and their own) to mobilize available sources of power to enact a more socially just engineering product or service.	To what degree can the community shape its own water destiny? To what degree can engineers’ feedback control system design promote community self-determination vis-à-vis water access?
4. Increasing resources and opportunities	...so the engineering product or service can increase for users and key actors access to resources (e.g., water, energy) and opportunities (e.g., steady income sources, access to education, technology, and/or infrastructure).	How would a slow-fill tank that centralizes water storage and collection address the above structural conditions? How would such a tank design promote a more equitable distribution of water (and related) resources and opportunities?
5. Decreasing risks and harms	...so the engineering product or service can reduce users’ or key actors’ exposure to risks (e.g., safety, environmental) and harms (restricted access to education, technology, and/or infrastructure).	How would a locally owned tank design decrease the risk of price gouging from private or government-owned water monopolies? How would access to less expensive water reduce the harms caused by households paying a large percentage of their monthly income to water bills?
6. Enhancing Human Capabilities	...so the engineering product or service can enhance human capacities such as bodily health, bodily integrity, senses, imagination, and thought, emotions, practical reason, affiliation (protecting entities that ensure preconditions for self-respect and non-humiliation regardless of sex, ethnicity, sexual orientation, etc.), play (recreation, laughter), and control over one’s political and material environment (Nussbaum, 2007).	How does improved access to clean water enhance, among others, bodily health; senses, imagination, and thought; affiliation; play; and control over one’s political and material environment?

For brevity, we limit further discussion on social justice in engineering and instead refer readers to several resources on the topic^{11, 12, 13, 14, 15}.

We were motivated to conduct this research for varying reasons, but all of us wish to improve engineering education and the field of engineering itself: a lofty goal, and one without which the research would probably never have happened. Since all three of us have tenure, we have not needed to worry about jeopardizing our positions for unusual pedagogical risk-taking at our institution. We experienced both unexpected support for and resistance against the research we describe. In general, we felt that the research funding from as prestigious an organization as the National Science Foundation alleviated many concerns from institutional constituents.

Methods and Results

To conduct our research, we incorporated numerous social justice and sociotechnical elements into one section of an IFCS class each during the Fall 2014 and Fall 2015 semesters. We collected data from surveys, focus groups, interviews, and assignments from students enrolled in this “with intervention” (WI) and a separate “without intervention” (WOI) section of the class. All required approvals were obtained by our institution’s Human Subjects review board. In this autoethnographic-inspired paper, we focus on reflections written by the primary instructor of the WI sections, as well as correspondence among members of our research team.

Like the majority of engineering educators, the lead instructor for the WI sections of IFCS received no formal instruction and had few informal experiences in integrating sociotechnical elements into ES core courses. How does one even begin to teach engineering students about social justice? During Fall 2014, a co-PI on the research team who is an expert on social justice in engineering visited the class and gave a 40-minute guest lecture introducing social justice and providing examples on how it can be applied in feedback control design for an auto-adjusting insulin pump. Although many students seemed interested and engaged, many clearly were not. One week later, the lead instructor emailed the co-PI’s to say:

“I had my first real challenge today from a student who came to office hours and said he didn’t think it’s reasonable to teach a topic as disconnected as social justice in a control systems engineering course he signed up for. It turned into a very productive discussion, and while we may not fully agree he definitely said he’d be interested to hear more in the future. So, that went quite well.”

In retrospect, the conversation with the student was actually the beginning of a downhill slide in which this student grew more and more oppositional, clearly articulating that sociotechnical integration was inappropriate for the class. Most students were less vehemently oppositional, instead expressing lower-level annoyance about needing to catch up with the other (WOI) section after this guest lecture. It became clear to the research team that the full-class guest lecture, although alleviating the engineering instructor’s discomfort in teaching the new topic alone, was ineffective as a teaching model. In fact, using a different instructor and separating social justice from technical content in a separate class may have served to reinforce the notion of technical-social dualism¹³ and have deprioritized social justice in the students’ minds.

Although the lead instructor did not keep a formal reflection log during the first semester of implementation, she did maintain a list of “Ideas to improve [IFCS] for Fall 2015.” This list reflects many of the expected problems for such a novel experiment:

- Students question social justice as a disconnected add-on
- Students are concerned about missing “content” when discussing social justice
- Students question the relevance of social justice
- Social justice is only spottily integrated
- Students are missing real-life connections

However, at the end of the Fall 2014 semester, other members of the research team interviewed both focus groups of 3-4 students and individuals enrolled in the WI and WOI sections. From these interviews, we found the students’ perspectives to be remarkably varied, with some students indicating the class was helpful in learning to connect social and technical elements, something they could take into other technical courses. For instance, one student said that “I think it’s good to relate those two things [technical and social] in your mind rather than having them be separate: ‘This is technical. This is social.’ You can make a connection between the two if you’re learning them side by side, or when you get like a Thermo problem in your work then automatically you jump to social justice rather than being exclusive.”

Nonetheless, the instructor used the above list of concerns, paired with brainstormed lists of possible solutions, to make changes that improved social justice integration during Fall 2015. We addressed the “disconnected add-on” and “missing ‘content’” concerns by having the lead instructor present the social justice definition and criteria gradually over the course of three weeks, taking 5-10 minutes per class period and *tying them directly into the technical material* each day using real-world examples. This technique—suggested by students in focus groups and interviews—also helped to address the fifth concern, which was addressed by adding more contextualized problems to the homework sets. In addition, having an extra year to plan and gain insight helped improve integration. Although analysis of the data from Fall 2015 has not been completed at the time of this writing, our hope is that the problem of students not recognizing the relevance of social justice will have been addressed through these and other improvements.

After the conclusion of the Fall 2014 semester and completion of the analysis, the lead instructor wrote the following remarks about the experience:

“I think my biggest takeaways from this initial integration are (1) that it is more time-consuming than I ever expected, and (2) that I am more bothered by a small number of nay-sayers than I would like to admit.”

Of course any new curricular development takes time, but for a traditionally-trained faculty member, part of the challenge in sociotechnical integration is learning to think more sociotechnically before it is possible to do a good job teaching students to do so. As James Huff said⁷, professorial self-doubt when trying something new likely causes stronger reactions in ourselves when we are challenged by students. However, the lead instructor also wrote:

“Reading the transcripts (from my class, after the semester ended) and attending the focus groups and interviews for students in the other [WOI] section of the class was interesting and very illuminating. I recommend all professors have a focus group run on their classes to learn more about what it is the students are struggling with. It is crazy how often I think I’ve said things that students report not hearing (e.g., real-world examples).”

Listening to and reading transcripts of focus groups run by a skilled colleague provided exceptional insights into curricular gaps, especially between what a professor thinks students are hearing and learning and what students report hearing. This experience has been one of the most unexpectedly positive elements of the research.

During the Fall 2015 semester, mixed emotions continued. After reading student responses to an in-class “keep-start-stop” survey midway through the semester, the lead professor wrote in a reflection log, “I finished tabulating the keep-start-stop results from yesterday’s class and am overall *relieved*” (emphasis added). A few weeks later, the conflicted emotions continued:

“It’s true, though, that I’m not utterly convinced that integrating SJ [social justice] specifically into IFCS is the best choice. Obviously I’m eager to hear more about what the students in yesterday’s focus group (my section) had to say, but it’s a real challenge to think through the connections without losing content, and *frankly I’m tired of being seen as further “other” beyond just the gender biases I have to confront*. Part of me wants to run next semester’s class with the same real-world examples as this semester’s (wind energy and active prosthetics) but without the explicit SJ content, just to see if it feels like as much of an uphill push.” (emphasis added)

Because of the insights gained in Fall 2014, a major change we made in Fall 2015 was to follow two application areas throughout the semester. We selected active prosthetic control and wind turbine control as two applications that have human/social impacts as well as ability to illustrate IFCS’s technical elements. We also added some individual homework problems (several related to water systems) and modified an assignment to include more human-centered and social justice elements. We created many Lecture Supplement documents (provided to students via the course web site) and used at least one of the wind or prosthetic applications at least briefly in over 50% of classes throughout the semester. We were therefore rather surprised when reading the focus group and interview transcripts to see very little mention of these applications in student responses. After some reflection, the lead instructor had an epiphany and sent the following email to the co-PI who had led the focus groups:

“I had the sudden inspiration that **of course** the students talked to you more about the water-related examples than the active prosthetics and wind turbine ones, because the water ones were assigned to them in homework [(HW)] assignments, whereas the wind and prosthetic ones were largely used as in-class examples and discussions – times when the students could be more passive. This seems so obvious to me after the fact that I can’t believe I didn’t think of it ahead of time. I did create two HW assignments around the prosthetic and wind examples, but both were too complex, so I think the students didn’t really get it (and I already know I have to make those more tractable for next semester). So, for next semester, I’ll include a few more concrete HW problems. I also had already planned to add some

additional in-class activities (handouts) for students to work through, and will make some of those wind and prosthetic-related.”

Despite talking the students through more concrete examples, those they remembered and chose to discuss during the focus groups and interviews were largely those that had required more engagement on their parts, i.e., those assigned in homework, which is supported by large quantities of research on active learning^{16,17}.

As every engineering professor knows, the struggle to balance content in an ES core course can be significant, and IFCS is no exception even without social justice integration. Beyond the ups and downs and the efforts required to include meaningful sociotechnical in-class examples and homework assignments, the biggest challenges centered on balancing content. The lead instructor included comments about content and being pressed for time many times in the Fall 2015 reflection log, including “Timing is always an issue. I regularly run out of time to discuss what I wanted to discuss...” “Content is the bane of my CSESJ [control systems engineering and social justice] activity.” By the second-to-last week of the semester, “Fundamentally, I’m just losing steam on the semester...With so many other things going on, I haven’t pressed the students to discuss SJ in class, and they haven’t brought it up on their own.”

Timing considerations are important for both the technical and social justice content. On the last day of the semester, two members of the research team were part of an engineering and social justice workshop. The day before, the lead instructor reflected:

“In reading through the materials for tomorrow’s ESJ [engineering and social justice] workshop, I was struck by the intensity of the learning opportunities required to teach SJ concepts such as contextual listening and identifying structural conditions. The establishment of trust required for true contextual listening may not be something that can be possible as a part of an already content-intense undergraduate engineering science class.”

Indeed, after discussing further with colleagues at the workshop, the team decided to focus on no more than three social justice criteria for the spring 2016 semester, aligning with the philosophy that it is better to teach a smaller subset of content well than a larger subset poorly.

A last epiphany of the semester occurred during revisions of the course’s semester project. In Fall 2014, students had been required to motivate a design specification by one or more social justice criteria. For example, in one of the most concrete and familiar cases with dubious social justice value, students could design a more robust controller to increase safety of the human operator. Although some teams went deeper, the overall results were unsatisfying. In Fall 2015, teams were required to incorporate social justice criteria into their initial problem statement, then use control systems technique to create a solution, as illustrated in Figure 2. The lead instructor reflected:

“The requirement to *motivate* the project by SJ [social justice] was a real brainstorm since it kept the students thinking about the bigger picture from the start; I had no actual complaints about this one, and more teams talked about SJ elements beyond just safety

(anecdotally, though I haven't done the formal analysis, "enhancing human capabilities" and "increasing opportunities and resources")."

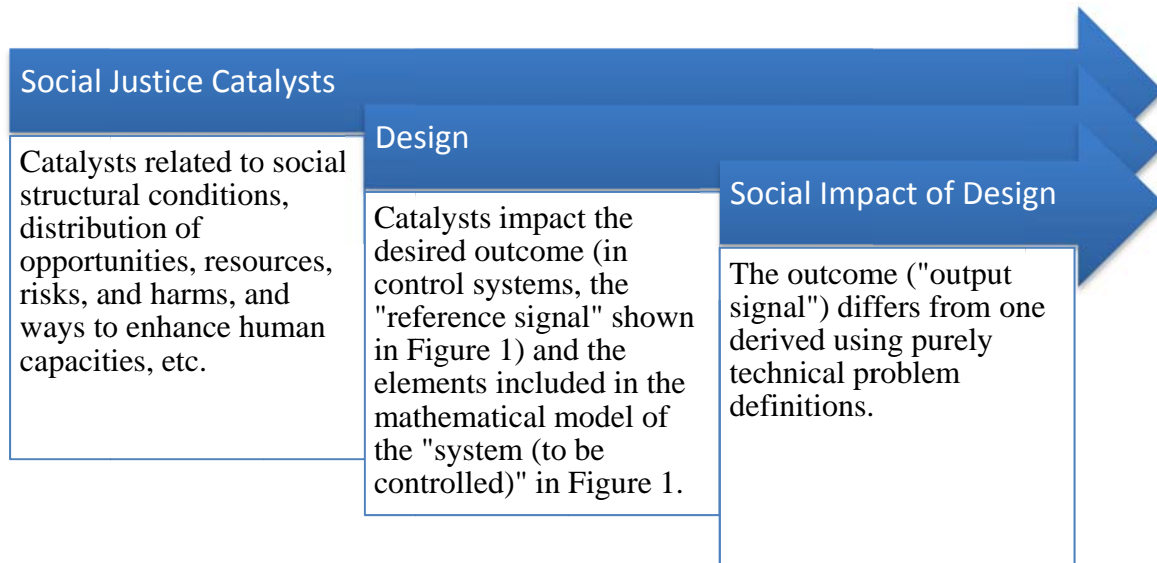

Figure 2: Social justice as a catalyst for problem definition, not just a design constraint

Although formal analysis has not yet been completed, we hope that this revised requirement supports students toward the path described by Downey (2015) toward improved problem definition, not just problem solving.

Finally, we had numerous affirming, encouraging interactions with students enthused by the sociotechnical integration. The lead instructor's last reflection included a note that "Reading the 'additional comments' from the students in their project reflections gave me a boost, too, since most of those who chose to write these were reasonably positive." One student made a point to say that the class was the favorite she had taken at CSM – a good reminder of the positive impact our innovations can have on individual students.

Conclusion

In this work-in progress paper, we have shared and discussed faculty reflections from a two-semester effort to integrate social justice into an introduction to feedback control systems undergraduate class. Some of the key barriers to sociotechnical integration include faculty knowledge, student pushback, and time and content constraints. Opportunities arose in terms of finding more meaningful ways to teach sociotechnical content through assignments and modifications to a semester project, better understanding of our own teaching, and a chance to reach students in new and different ways.

To summarize our lessons learned, we have framed them here as instructional suggestions—ones we wish we had known when starting this project but are glad to have learned.

1. Give up the idea that teaching social justice is going to be like teaching engineering science concepts or problem solving. It's not that you **teach** social justice as much as you *make it visible* to students.
2. During the first course iteration, integrate the most relevant social justice dimensions **gradually**, forging solid connections between course problems and one, two, maybe three of the six criteria in Table 1. Do not try to "do it all" at first.
3. Given the predominant student learning preference to understand how social justice relates to the problem space, avoid abstract discussions of social justice, and focus on clear, **concrete** connections between an open-ended, technical problem and one or more of the most relevant engineering for social justice criteria. Also, we found that what the instructor considered "concrete" was abstract for students coming to those technical examples for the first time.
4. Recognize that part of the challenge in making social justice visible in the engineering sciences runs against engineering educational **norms**, which privilege closed-ended problems that are easier to grade. By contrast, contextualized, open-ended problems are more similar to actual engineering practice and encourage a) learning from failure, b) learning how sociotechnical dimensions can be connected or inseparable, and c) learning to make the shift from social or technical thinking to sociotechnical thinking. Yet they also take more time, planning, and thought to integrate well.

In future work, we are in the process of recording reflections for the third iteration of the course, which will enrich the data for further and more complete autoethnographic analysis. Analysis of data collected from students enrolled in the second and third iterations of the course has also not yet been completed. Outcomes from analysis of this data can be compared to faculty reflection data to generate further insights.

Acknowledgments

This material is based upon work supported by the National Science Foundation under Grant No. EEC-1441806. Any opinions, findings, and conclusions or recommendations expressed in this material are those of the author(s) and do not necessarily reflect the views of the National Science Foundation.

References

1. Bijker, Wiebe E., Hughes, Thomas P., and Pinch, Trevor, *The Social Construction of Technological Systems: New Directions in the Sociology and History of Technology*, Cambridge, MA: MIT Press, 1987.
2. Lucena, Juan and Jon Leydens, "From Sacred Cow to Dairy Cow: Challenges and Opportunities in Integrating of Social Justice in Engineering Science Courses," *Proceedings of the ASEE Annual Conference and Exhibition*, Seattle, WA, 2015.
3. Downey, Gary, "Are Engineers Losing Control of Technology?: From 'Problem Solving' to 'Problem Definition and Solution' in Engineering Education," *Chemical Engineering Research and Design*, **83**(6): 583-595, Jun. 2005.
4. Johnson, K., Leydens, J. Moskal, B., Fantasky, J., and Silva, D., "Social Justice in Control Systems Engineering," *Proceedings of the ASEE Annual Conference and Exhibition*, Seattle, WA, 2015.

5. Johnson, K., J. Leydens, B. Moskal, and S. Kianbakht, "Gear switching: From 'technical vs. social' to 'sociotechnical' in an introductory control systems course," to appear in the *Proceedings of the American Control Conference*, Boston, MA, 2016.
6. Ellis, Carolyn, Tony Adams, and Arthur Bochner, "Autoethnography: An Overview," *Forum: Qualitative Social Research*, **12**(1), art. 1, January 2011.
7. Huff, James, "Humanizing Signals and Systems: A Reflective Account," *Proceedings of the ASEE Annual Conference and Exhibition*, Seattle, WA, 2015.
8. Matusovich, Holly, Marie Paretto, Lisa McNair, and Cory Hixson, "Faculty motivation: A gateway to transforming engineering education," *Journal of Engineering Education*, **103**(2): 302-330, 2014.
9. Edwards, Andrés, *The Sustainability Revolution: Portrait of a Paradigm Shift*, Gabriola Island, British Columbia: New Society Publishers, 2005.
10. Leydens, Jon and Juan Lucena, "Social Justice: A Missing, Unelaborated Dimension in Humanitarian Engineering and Learning Through Service," *International Journal for Service Learning in Engineering*, **9**(2): 1-28, 2014.
11. Adams, Maurianne, Lee Anne Bell, and Pat Griffin (Editors), *Teaching for Diversity and Social Justice: A Sourcebook*, Routledge, 2nd Ed., 2007.
12. Baille, Caroline, Alice Pawley, and Donna Riley, *Engineering and Social Justice*, Purdue University Press, 2012.
13. Cech, Erin, "The (Mis)framing of social justice: Why ideologies of depoliticization and meritocracy hinder engineers' ability to think about social injustices," in *Engineering Education for Social Justice: Critical Explorations and Opportunities*, (ed.) Juan Lucena, New York: Springer, pp. 67-84, 2013.
14. Lucena, Juan (Ed), *Engineering Education for Social Justice: Critical Explorations and Opportunities*, Springer, 2013.
15. Riley, Donna, *Engineering and Social Justice*, San Rafael, CA: Morgan and Claypool Publishers, 2008.
16. Bransford, John D., Brown, Ann L., and Cocking, Rodney R., (Editors), *How People Learn: Brain, Mind, Experience, and School*, Washington, DC: National Academies Press, 2000.
17. Ambrose, Susan A., Bridges, Michael W., DiPietro, Michele, Lovett, Marsha C., Norman, Marie K., *How Learning Works: Seven Research-Based Principles for Smart Teaching*, San Francisco, CA: Jossey-Bass, 2010.