AC 2011-151: TEACHING SURFACE MODELING TO CAD/CAM TECHNOLOGISTS

Derek M. Yip-Hoi, Western Washington University

Derek Yip-Hoi has a Ph.D. in Mechanical Engineering from the University of Michigan. He has broad experience in CAD/CAM and geometric and solid modeling from research and teaching experiences at UM and the University of British Columbia. Currently he coordinates the CAD/CAM instruction in the Engineering Technology Department at Western Washington University.

Teaching Surface Modeling to CAD/CAM Technologists

Abstract

This paper discusses in detail the importance of surface modeling for CAD/CAM technologists and how it supports a broad range of courses in the MET program that students must complete to graduate. The underlying strategy for teaching a course on surface modeling is also presented. This is driven from the different techniques by which the design intent or style for the model is specified. One of these techniques is to use 3D laser scanning to capture point cloud data from a physical scaled model of the product being designed. This technique is for example used in automotive body design where scaled models are created as part of the styling process. Students get the opportunity to use a FARO Arm mounted scanning system to collect data for an automotive body shell of their choosing from which a CATIA surface model is manually constructed. This paper will highlight the approach used. Examples of student project work will be presented. These projects are designed to include both a group and individual component. Teams work collaboratively to construct a surface model of an automotive body. Individually, each student must then add ancillaries such as wheels, mirrors, scoops or spoilers to complete their own design. While the group component emphasizes collecting data and applying surface modeling techniques to this data, the individual component allows students to creatively use the surface modeling techniques to style the ancillaries they choose. Feedback from students show that there is strong agreement that this course deepens and expands their CAD skills and that they value exposure to new technologies such as 3D scanning.

Introduction

An option in a Manufacturing Engineering Technology (MET) program that focuses on the development of CAD/CAM skills has been recently introduced in the Engineering Technology Department at Western Washington University (WWU). These skills include in-depth exposure and training in the use of state-of-the-art Computer-Aided Design software tools, and the programming and operation of Computer-Numerical Controlled machine tools. Students apply their knowledge from these areas in other courses where molds and tooling are designed and fabricated. Beyond an introductory exposure to CAD in freshman courses, students taking this option must complete two advanced junior level CAD modeling courses one of which exposes them to the use of advanced surface modeling using CATIA. Surface modeling is important in that it provides the capability to model a diversity of complex shapes far beyond what is possible using a feature-based parametric modeling tool. It is an indispensable modeling environment for developing products with freeform shapes. By studying and applying these techniques students are able to grasp the difference between solid and surface models, learn new geometric modeling and management techniques and be able to convert surfaces to solids as is necessary for the creation of molds, tooling and properly dimensioned engineering drawings.

This paper summarizes the approach taken and experiences in teaching a junior level surface modeling course at ET-WWU designed to expose CAD/CAM technologists to this important CAD domain. It will start by motivating the value of surface modeling in developing key skills that have been identified as essential to the education of a CAD/CAM specialist. This will be followed by an overview of the CAD/CAM curriculum taught highlighting the role that the

surface modeling class plays in supporting other junior and senior level core requirements. Details of the course will then be given. Here some attention will be given to techniques that students are introduced to for inputting data that guides the modeling activity. Included in these is the use of a laser scanning system that is used to collect data from a physical prototype for which a surface model is to be constructed. This will lead into a discussion of the project work that students must complete along with examples. This accounts for a major component of the course grade. Finally a discussion of assessment and feedback from course evaluations will be given.

What is Surface Modeling?

Historically, surface modeling followed wireframe modeling and preceded solid modeling in the evolution of CAD/CAM systems. One of the earliest uses of surface modeling in CAD can be found in the automotive industry. Bezier used the surface forms named after him to model surfaces used by Renault as part of the UNISURF CAD/CAM system¹. This provided the foundation for generating tool paths to drive NC machines for cutting stamping dies. Today Surface Modeling follows a parallel track to solid modeling which itself has evolved to include feature-based and parametric technologies. All major CAD systems have a surface modeling module (or workbench) that allows these models to be created either independently or integrated with a feature-based, parametric modeled. When integrated, surfaces that are generated are combined with solid models using one of several surface-to-solid conversion tools e.g. *Thicken, Close, Sew* (CATIA terminology). This allows these hybrid models to be further manipulated as a solid.

There are also numerous standalone NURB surface modelers such as Rhino, 3D Studio Max and Maya where the focus is on providing highly interactive modeling tools that give the designer the greatest freedom in shaping a surface. These environments are typically used by Industrial Designer and artisans (e.g. in Jewelry Industry). These models can be imported into a CAD/CAM system using a neutral format (e.g. IGES or STEP) for use in tool path generation. However, they lack the associativity that exists when the CAD model is created in the native format.

Supporting Skill Set Development

The following table is a list of key skills that are viewed as essential to the development of a CAD/CAM technologist along with a brief explanation of how surface modeling supports each. In summary, Surface Modeling impacts in some way each of the skills identified. In particular it introduces students to a different approach to modeling over what they learn in feature-based, parametric modeling where the goal is a 3D solid model. This skill gives greater freedom in creating and managing more complicated and styled shapes while at the same time providing the capability to integrate these shapes back into the solid modeling environment. They learn how to use different types of inputs to create a framework for the surfaces created and how to generate 3 and 5-axis tool paths and machine products and tooling from these.

	Desired Skill	Support provided by Surface Modeling
1	An ability to efficiently model a wide range of products of varying complexity in particular those that require machining, joining and molding.	Surface modeling is critical to modeling any product with freeform styling. Essential for many molded parts and the tooling used to create these.

2	Competency in generating engineering documentation from CAD models that conform to accepted drafting standards.	Creating drawings for freeform surface models requires a different approach to those for prismatic parts.
3	Acquire a basic understanding of geometric and solid modeling concepts that form the core of CAD/CAM systems.	Surface modeling provides a means for exposing students to the underlying concepts in modeling curves and surfaces. Concepts such as control points, continuity, tangency/curvature and their role in shaping surfaces are introduced.
4	Be able to organize and manage CAD data efficiently.	Surface models can be structured as unordered geometry i.e. the feature tree order does not have to represent the design history. A large amount of geometric entities are typically created. These must be grouped into sets for the designer to easily navigate the model.
5	Competency in utilizing various types of inputs to guide the creation of 3D CAD models.	3D laser scanning and sketch tracing are two techniques that provide inputs to surface modeling.
6	An ability to collaborate in creating CAD models and using these to fabricate tooling and components.	It is possible with surface modeling for a single part to be decomposed into regions that can be independently modeled then integrated into a single model. This can be leveraged to promote collaboration in a similar manner to assembly modeling.
7	An understanding of how CAD supports engineering analysis.	Curvature and draft analysis tools are available for use within surface modelers. These can be used to show how the CAD model can be analyzed for smoothness and removal from a mold.
8	An ability to quickly adapt to different modeling environments.	Exposes students to a different type of modeling from feature-based parametric solid modeling. Surface construction techniques and operations are more complicated than those used in 3D parametric modeling.
9	Be able to generate tool paths for manufacturing a wide range of products and tooling.	Surface models are extensively used for 3 and 5-axis tool path generation and verification.
10	Skill in programming and operating CNC equipment for machining products and tooling.	Requires knowledge of post-processing since surface machining cannot be done manually. Verification, set-up and tooling are different than prismatic machining.

Table 1. Surface Modeling Support of CAD/CAM Technologist Skill Set

Surface Modeling in the CAD/CAM Curriculum

Figure 1 summarizes the primary courses that expose students to CAD/CAM technology in the curriculum. All ET students with the exception of the Electronics program are required to take an introductory CAD class (ETEC 113) and a manufacturing processes course (ETEC 246). These are new additions to the curriculum (246 will be taught for the first time in Fall 2011) replacing three other courses in an effort to consolidate instruction and reduce resource requirements. Students are introduced to feature-based parametric modeling and generative drafting using CATIA in ETEC 113. They will receive additional exposure in ETEC 246 where they are required to use CATIA in their project to model and generate tool paths to water-jet cut a sheet metal component. There are also plans in the near future to include an introduction to the Sheet Metal Design module in CATIA. This will provide students with an example of a *Design for Manufacture* CAD application. In addition, students taking the CAD/CAM option are required to take three additional CAD classes one of which is on Surface Design using CATIA. Details of the other two courses on *Assembly Modeling and Mechanisms* and *CAD Automation* can be found in references cited in the Bibliography^{2,3}.

For CAM, all MET students are required to take an introductory course on NC programming (ETEC 322) that utilizes the CATIA prismatic CAM module to expose them to tool path programming. Additionally, students taking the CAM option do an advanced CNC class (ETEC 426), and courses on mold and tooling design (ETEC 335 and 427). It can be seen from Figure 1 that the Surface Design class is a pre-requisite for both the advanced CNC and plastics mold design courses. In both cases students complete projects that require machining of surfaces. Surface models must first be created in CATIA then used to generate tool paths using the 3-axis

machining module. Surface modeling and machining may also be used in the CAD/CAM capstone senior project depending on the topic.

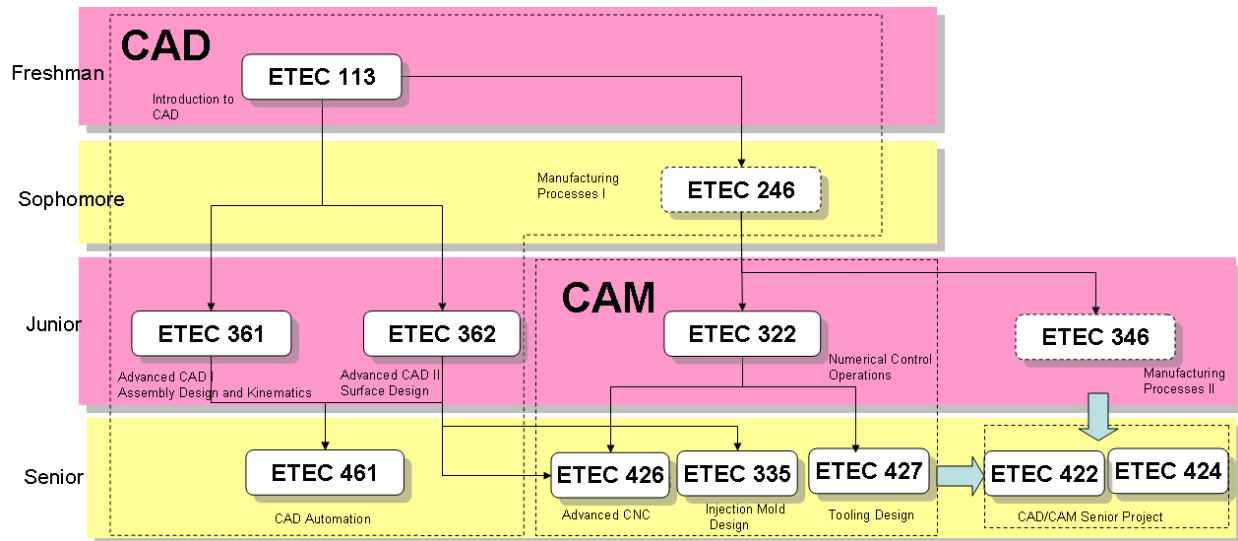

Figure 1. Primary CAD/CAM Courses in Program

Overview of Surface Modeling Course

Since WWU operates on the quarter system, courses are scheduled over a 10 week period. As a four credit offering, ETEC 362 meets for two 3 hour periods in the department’s CAD laboratory. Though the size of the lab caps enrollment at 48 students, the actual class size typically does not exceed 25 students. This adequately meets the demand for the CAD/CAM program while providing space for students in other programs wishing to take this course as an elective.

The objectives of the course are as follows:

- To introduce the modeling, management and analysis of curves and surface models in state-of-the-art CAD/CAM systems.
- To provide exposure to the use of different inputs to guide surface modeling of a physical shape.
- To expose students to the challenges faced in team-based modeling of surface models.
- To enhance the student’s understanding and skills in parametric modeling of products, molds and tooling.

A typical 3 hour meeting of the class would contain background material on the scheduled topic, instructor led exercises and tutorial exercises that the students would complete from the training manuals that are used^{4,5}. Later in the term parts of sessions are set aside to allow students to work on their projects “in-class”. This helps provide an opportunity for group project teams to meet during class time and for the instructor to be able to provide guidance in problem areas that are encountered. Outside of the regularly scheduled class time students must work on a weekly homework assignment that makes them apply the material covered in the tutorials independent of

instruction. There are also project deliverables that are scheduled for submission throughout the term.

Capturing the Framework for a Concept

Though the course is on surface modeling, significant attention is given to different techniques for capturing and inputting the framework of a concept into the CAD system and utilizing this framework to control the creation of a surface model. These input techniques are summarized in Figure 2. Four input types are identified at the top. Of these, *Interactive Modeling*, *Scanning Digitizing* and *2D Tracing* are introduced. The fourth approach, *Physical Modeling* is covered in the senior level *CAD Automation* course (ETEC 461). These techniques require exposing students to additional technologies during the course of the term. These include:

- **3D Laser Scanning:**
This is accomplished using a FARO⁶ Arm mounted line laser in conjunction with the Geomagic Studio 12⁷ software application.
- **Manipulation of 3D Point Clouds:**
Most of this is performed using CATIA's *Digitized Shape Editor* Workbench. This allows students to control the size of point clouds, generate and close meshes, align and merge clouds and position clouds correctly within the part's coordinate reference frame.
- **Sketch Tracing:**
Orthographic views of a component can be imported as images into a CATIA assembly using the *Sketch Tracer* Workbench. These images can be sketched over with interactive *3D Curves* to generate wireframe geometry for building surfaces.
- **Interactive Curve Shaping:**
3D Curves from CATIA's *Styling* Workbench are used to interactively shape these curves in orthographic views.

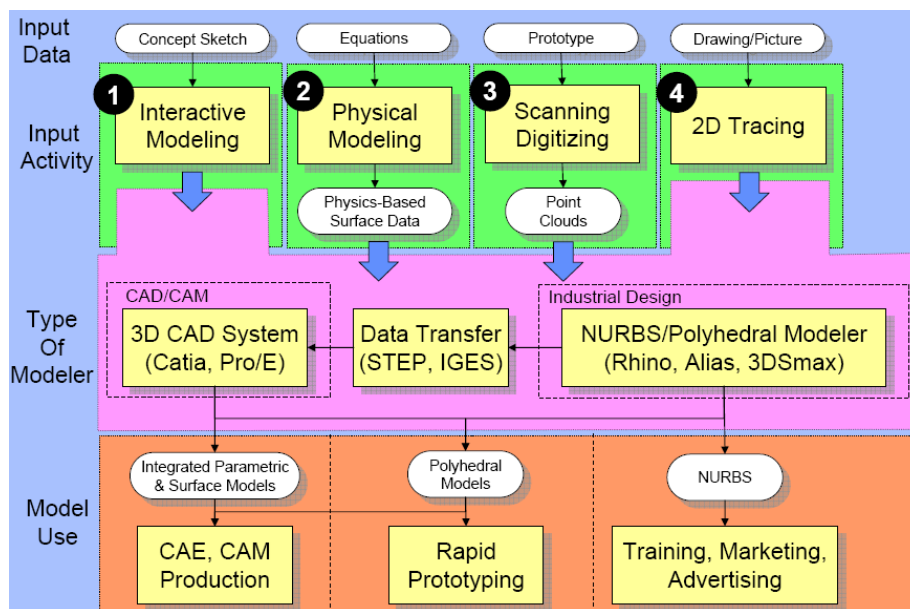

Figure 2. Inputs Used in Teaching Surface Modeling

Project Overview

A key component of the course is the completion of a term project. This project has both a group and individual component. The former encourages students to collaborate in building a surface model. This challenges them to think about and utilize ways to create and manage their model in a manner that allows it to be shared and accessed concurrently. The individual component provides each student with an opportunity to creatively and independently apply the surface modeling techniques they have been introduced to.

Group Component

This part of the project requires each team to build a surface model of an automobile body. The sequence of steps is as follows:

- **Select body style:** Each group must start with a physical representation of their body. It has been found that 1/16th scale remote control racer shells created by thermoforming provide a good variety of options for students to choose from. Since it is typical that several students in the course are majoring in the department's Vehicle Design program, they may also have examples of physically sculpted body styles that they may wish to use.

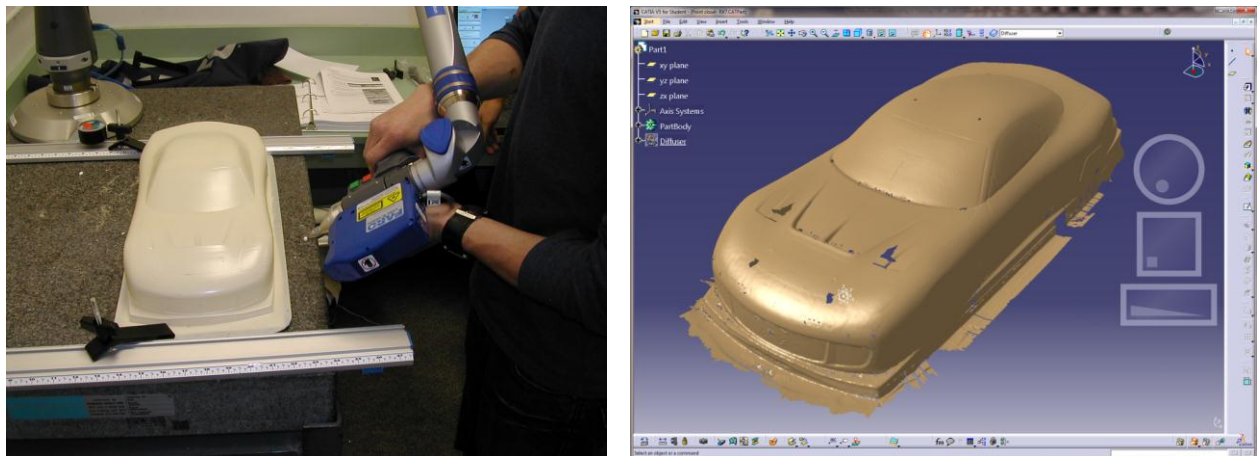

Figure 3. Scanning of Body Shell and Resulting Mesh in CATIA

- **Scan model:** Using a scanning laser mounted on the end of a FARO arm each group scans their body (Figure 3). Since most are symmetrical and there is not a requirement for a closed mesh, only half the body need be scanned. The Geomagic Studio software application with a FARO arm plugin is used to collect and process the point cloud. This typically involves creating multiple scans that cover the entire surface, then merging and decimating these point clouds to manage size. An output .STL or .xyz file type is generated.
- **Input Point Cloud into CATIA and Manipulate:** This is done using the *Digitized Shape Editor* workbench. Manipulation involves orienting and positioning the point cloud within the models coordinate reference frame, meshing, mirroring and merging to create a full body and healing to eliminate non-manifold geometry and fill large holes (Figure 3).
- **Input 2D Images of Body:** Images of orthographic views are captured from renderings of the mesh that has been created. These are input into CATIA using the *Sketch Tracer* workbench and aligned with the mesh (see Figure 5).

- **Create a Modeling Plan:** This is done on paper and is necessary to allow feedback from the instructor prior to modeling and to allow groups to distribute the work. The plan should show supporting wireframe geometry and surface types that will be created in building the surface model. Groups are encouraged to use a range of different techniques for practice even if they are not the most optimal. Figure 4 shows a sample of what is expected from each group.

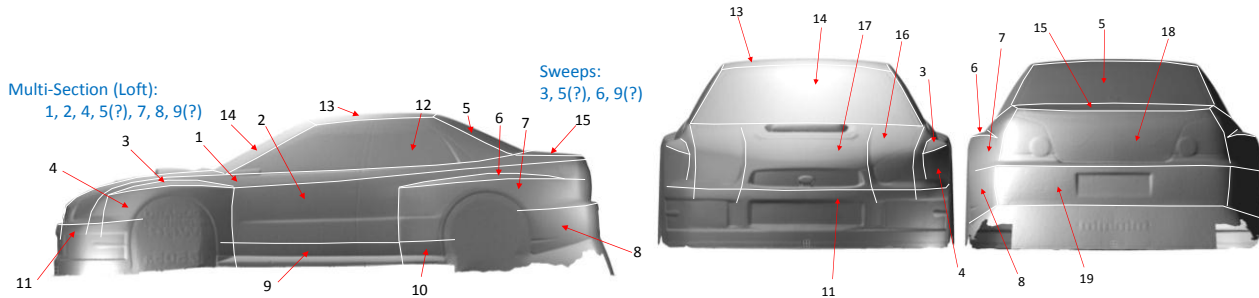

Figure 4. Expected Result for Planning the Surface Model

- **Build Surface Model:** Groups execute the plan they have created to build the surface model. Interactive 3D Curves are pulled and shaped using the 2D orthographic images as guides to capture the long body lines (see Figure 5). The mesh is used to create other foundational wireframe geometry such as sections for lofts or profiles for sweeps. Surfaces are built over the wireframe geometry. Control points are manipulated to shape surfaces to closely match the mesh shape. Surface operations (e.g. Split, Trim) are applied in many cases to generate edges. Generating these edges so that all surfaces meet correctly is one of the most challenging tasks for the students. Since symmetry is also employed to reduce the amount of modeling, it is also challenging for them to enforce curvature continuity across a symmetry plane. The left image in Figure 6 shows an example of the expected result from this step.

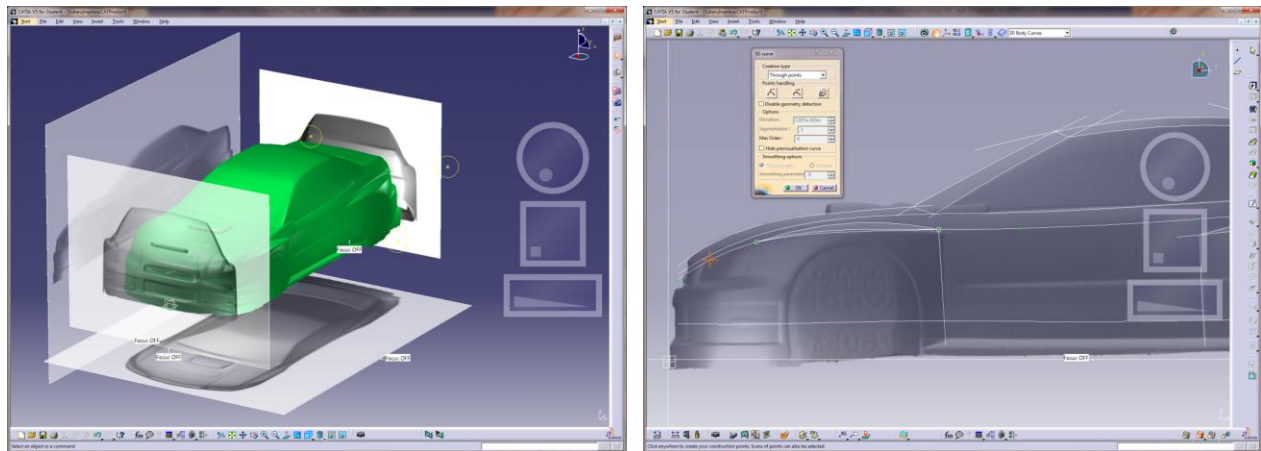

Figure 5. Orthographic Images Setup in the Sketch Tracer used to Create Body lines with Interactive 3D Curve Tool

Individual Component of Project

With a completed surface model created by the group, each member is required to develop their own variation of the body theme through a combination of modifications and the addition of ancillaries. These include components such as lights, mirrors, wheels, spoilers, bumpers, scoops,

mud guards and diffusers. This part of the project encourages students to use their imagination in developing and incorporating interesting shapes into their modifications again using wireframe and surface modeling techniques in CATIA. The goal is a complete exterior look for the automobile. An example is shown in the middle image of Figure 6. Here, a bumper, rim and wheel and mirrors have been added. Each student is required to generate a photo-realistic rendering of their final design using either the *Photo Studio* workbench in CATIA or another renderer of their choosing. Again Figure 6 illustrates an example.

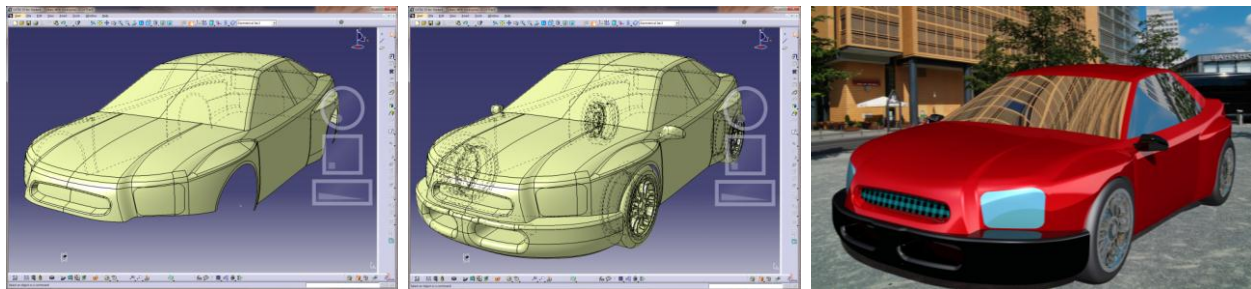

Figure 6. Final Surface Model, with Added Ancillaries and Final Rendering

Examples of Project Work

Samples of student work are shown in Figure 7 at the end of this paper. Additional examples of individual project work can be clearly seen. There is also an evident variation in effort and skill in achieving realism in the final rendering. This can be attributed to exposure to Industrial Design CAD work that some of the students have experience with as a result of taking electives in this program. It should be noted that achieving realism is not a primary goal of the project as it would be in courses required in Industrial Design.

Assessment

Assessment of CAD classes becomes more challenging as greater realism is required and open-ended assignments are introduced. ETEC 362 uses several techniques to assess student performance. These are:

- **Tutorial work (20%):** This portion of the grade evaluates student attendance at tutorials and completion of assigned exercises from the training manuals. Students are also expected to follow along with demos given by the instructor. Completion of these is also graded. This part of assessment measures whether or not a student has exposed themselves to the material. Demonstration of independent application of the material is not required.
- **Homework (25%):** This evaluates how well a student can apply a particular surface modeling technique without detailed instructions. Weekly assignments are given that are focused on the topics covered in the tutorials. Students must demonstrate an ability to think beyond the step by step instructions of the tutorials to be able to complete these assignments.
- **Project (Group – 20%, Individual – 25%):** As discussed earlier, students are given leeway to plan their modeling of an automobile body. Both the group and individual component require a high level of understanding of how different surface techniques work and when they should be used. A modeling planning is required to provide a basis for discussion with the instructor.

Students must demonstrate sophistication in their application of techniques and achieve realism in their final models.

- **Mid-Term (10%):** This is given towards the end of the term after significant time has been spent on the project. It is designed to test a student’s intuitive feel for the subject. The time constraint tends to distinguish students who are just better at CAD modeling. These students instinctively see the right choices and do not spend a lot of time searching for the technique to use in their manuals (the exam is open book).

Feedback from Course Evaluations

In addition to standard university course evaluations, students are asked each offering of ETEC 362 to provide feedback on how this course directly impacts their growth in CAD skills. Table 2 list these questions along with statistical data on the responses from students for two classes offered two years apart. Responses from 36 students (17 from 2008 and 21 from 2010) are included. Each question was answered on a scale of 1 to 5 (disagree to strongly agree). It can be seen that:

- There was a strong sense amongst the students that this course deepened their CAD skills in general and introduced them to new techniques in surface modeling (questions 1 to 3 and 7).
- Students see value in learning techniques such as 3D scanning as part of their study of surface modeling (question 4).
- There was a marked improvement in responses to questions 6 and 9 between the two samples. This is a result of changes made in instruction that gave more attention to the issues of CAD data organization and the use of curvature analysis tools in solving continuity problems.
- The responses to question 10 show that students appreciate the importance of planning before attempting to create a model. At the same time responses to 10 show that more can be done to help them visualize surface types in an existing design. This is much more complicated than the process of constructing a feature-based parametric model. Case studies that highlight the application of different surface modeling techniques can be used to help students develop this skill.
- Questions that evaluate teamwork and communication (12 to 15) received the lowest scores with highest variability. This is typical of team-based projects where some teams when members are chosen by association tend to be dysfunctional. This leads to a bad project experience that is reflected in their responses to these questions.

	Mean			Standard Deviation		
	2010	2008	Both	2010	2008	Both
1 Become more skilled at using a 3D parametric CAD system.	4.526	4.529	4.528	0.612	0.514	0.560
2 Use techniques for 3D parametric CAD modeling you were not aware of before.	4.526	4.765	4.639	0.697	0.562	0.639
3 Understand and apply the surface modeling techniques available in CATIA.	4.368	4.471	4.417	0.831	0.874	0.841
4 Use inputs such as sketches/pictures/3D point clouds to assist building models.	4.316	4.529	4.417	0.946	0.624	0.806
5 Understand strategies for wireframe and surface design.	4.368	4.235	4.306	0.684	0.970	0.822
6 Understand how to organize CAD data to increase usability and management.	4.368	3.824	4.111	0.831	0.809	0.854
7 Use a range of different workbenches in CATIA to accomplish a modeling task.	4.421	4.176	4.306	0.607	0.809	0.710
8 Integrate surface design with solid modeling (part design).	3.842	3.824	3.833	0.834	0.809	0.811
9 Analyze and fix problems in surface models.	3.579	2.882	3.250	0.961	0.928	0.996
10 Be able to decompose a physical object into surface types.	3.842	3.765	3.806	0.834	0.970	0.889
11 Appreciate the importance of planning before attempting to create a CAD model.	4.526	3.824	4.194	0.772	1.074	0.980
12 Work together on a team to set and meet team goals.	3.947	3.588	3.778	1.268	0.939	1.124
13 Listen, cooperate, and encourage participation with team members.	3.947	3.471	3.722	1.079	1.231	1.162
14 Verbally present ideas in a clear, concise manner.	3.895	3.059	3.500	0.809	1.249	1.108
15 Plan and deliver presentations.	3.316	2.941	3.139	1.376	1.345	1.355

Table 2. Student Feedback for ETEC 362

Conclusions

This paper highlights the importance of surface modeling in a curriculum to develop CAD/CAM technologists. Its study plays a role in developing each of the skills identified as important to a practicing technologist in this field. The approach used to teaching surface design in a course that is part of the curriculum is presented. At the core of this is a term project that utilizes both a team and individual component to model the exterior of an automobile. Students learn how to use different techniques for capturing the concept of their design and using this to guide the construction of their surface model. These include the use of a 3D laser scanning system mounted on a FARO arm and sketch tracing. Feedback from students show that there is strong agreement that this course deepens and expands their CAD skills and that they value exposure to new technologies such as 3D laser scanning.

Bibliography

1. Bezier, P.E., *How Renault Uses Numerical Control for Car Body Design and Tooling*, SAE Paper 680010, Society of Automotive Engineers Congress, Detroit, MI, 1968.
2. Yip-Hoi, D., *CAD Instruction Techniques for Advanced Assembly Modeling and Mechanisms Design*, Proceedings of the 2010 American Society of Engineering Education Annual Conference, Louisville, Kentucky, June 20th – 23rd.
3. Yip-Hoi, D., *Strategies for Teaching CAD Automation to Engineers and Technologists*, Proceedings of the 2010 American Society of Engineering Education Annual Conference, Louisville, Kentucky, June 20th – 23rd.
4. ASCENT, *Introduction to Surfacing*, CATIA V5R19, 2010.
(http://www.ascented.com/courseware_CATIA_Intro_Surface.htm)
5. ASCENT, *Advanced Surface Design*, CATIA V5R19, 2010.
(http://www.ascented.com/courseware_CATIA_Advanced_Surface.htm)
6. <http://www.faro.com/FaroArm/Home.htm>
7. <http://www.geomagic.com>



Figure 7. A Collage of Samples of Student Work