

**2013 American Society for Engineering Education
Pacific Southwest Section Conference**
University of California, Riverside, April 18-20, 2013

2013 ASEE PSW Conference Proceedings

University of California, Riverside
Thursday April 18th – Saturday April 20th, 2013

“Engineering Education in a Global Context”



Conference Website: <http://www.smccd.net/accounts/enriquez/asee-psw/>
ASEE PSW Section Website: <http://www.csupomona.edu/~sparisay/ASEE/PSW/>
Host Institute Website: <http://www.engr.ucr.edu/>

Conference Editors

- Enriquez Amelito Cañada College
- Gossage Lily California State University, Long Beach
- Ozer Nilgun San Francisco State University
- Marayong Pannada California State University, Long Beach
- Wang Jun University of California, Riverside
- Abbaschian Reza University of California, Riverside

Conference Reviewers

- Abbaschian Reza University of California, Riverside
- Amin Mohammad National University
- Amini Shaahin University of California, Riverside
- Bangs Karen California Polytechnic State University San Luis Obispo
- Benson Bridget California Polytechnic State University San Luis Obispo
- Brian Self California Polytechnic State University San Luis Obispo
- Cardenas Mary Harvey Mudd College
- Celik Ozkan San Francisco State University
- Chan Tammy California State University, Los Angeles
- Costea Ileana California State University, Northridge (CSUN)
- Dal Bello Dominic Alan Hancock
- Darwish Muge Mukaddes Texas tech University
- Demiryont Hulya Eclipse Energy Systems Inc.
- Enriquez Amelito Cañada College
- Gossage Lily California State University, Long Beach
- Hawley Harmonie California State University, Fullerton
- He Nannan Minnesota State University at Mankato
- Herold Jim University of California, Riverside
- Jacobitz Frank University of San Diego
- Jiang Hao San Francisco State University
- Kateeb Ibraheem North Carolina A&T State University
- Kim Jin-Lee California State University Long Beach
- Lande Micah Arizona State University
- Lanning David Embry-Riddle Aeronautical University
- Lu Stephen University of Southern California

- Macedo Jose California Polytechnic State University San Luis Obispo
- Marayong Pannada California State University, Long Beach
- Naish David California State University Fullerton
- Orwin Liz Harvey Mudd College
- Ozer Nilgun San Francisco State University
- Phillips Richard Harvey Mudd College
- Prodanov Vladimir California Polytechnic State University San Luis Obispo
- Radharamanan Ramachandran Mercer University
- Rezaei Amir Cal Poly Pomona
- Rice Dennis University of California, Riverside
- Shafahi Maryam California Polytechnic State University
- Shiller Barry San Francisco State University
- Sinha Bhaskar Raj National University
- Smestad Greg Sol Ideas Technology and Development
- Taufik Taufik California Polytechnic State University San Luis Obispo
- Teh Kwok Siong San Francisco State University
- Tiwari Binod California State University, Fullerton
- Vahid Frank University of California, Riverside
- Wang Jun University of California, Riverside

Table of Contents

International Research/education Collaboration on GaN LED/LDs between Cal Poly (USA) and PKU (China)	1
<i>Xiaomin Jin a, Xiao-hua Yu a, Xiang-Ning Kangb, and Guo-Yi Zhangb</i>	
Engaging Community College Students in Research using Summer Internship on Analysis of Performance Degradation of Integrated Circuits Due to Transistor Aging Effects in Nano-Scale	10
<i>John Paulino, Jesus Garcia, Joshua Lohse, Hector Prado, Atul Balani, Sridevi Lakshmipuram, Cheng Chen, Amelito G. Enriquez, Hao Jiang, Hamid Mahmoodi, Wenshen Pong, Hamid Shanasser</i>	
Development and Use of a Construction Engineering Gaming Simulation in the Global Environment	29
<i>Thomas M. Korman, Hal A. Johnston, Lloyd Crask</i>	
Integrating Earthquake Engineering into Community College Student Educational Experience through a Summer Internship	37
<i>Cheng Chen, John DeAndreis, Peter Moala, Agustin Robles, Jose Valdovinos, Qiming Zeng, Amelito G. Enriquez, Wenshen Pong, Hamid Shanasser, Hao Jiang, Hamid Mahmoodi</i>	
Engaging Undergraduate Students into Advanced Earthquake Engineering Research	46
<i>Cheng Chen, Jose Valdovinos, Frank Sanchez, Nelly Avramova, Hector Santillano and Robert Hartsock</i>	
Work In Progress: Stepping Back and Letting Students Take the Lead – Student-led Projects for a First-Year Introduction to Engineering Course	53
<i>Matthew T. Siniawski, Adam R. Carberry, Nazmul Ula</i>	
A Project-based Approach for a Design and Manufacturing Laboratory Course	55
<i>Matthew T. Siniawski, Adam R. Carberry, Rafiqul I. Noorani</i>	
Engaging Underrepresented Community College Students in Engineering Research.....	64
<i>Hao Jiang, Jose Carrillo, Alam Salguero, Ellaine Talle, Enrique Raygoza, Xenia Leon, Ben Lariviere, Amelito G. Enriquez, Wenshen Pong, Hamid Shahnasser, Hamid Mahmoodi, Cheng Chen</i>	
Development of International Mobility Program in Micro and Nanotechnology: Lessons Learned.....	73
<i>Jesús Acosta-Iriqui, Eniko T. Enikov</i>	
Work-In-Progress: Enhancing Students’ Learning in Introductory Power Electronic Course Using an LED Driver Project.....	81
<i>Taufik, Dale Dolan</i>	
Easy Tracking System: a Valuable Outcome of a Student Capstone Project	87
<i>Mohammed Alani, Alaa Ayoob, Jino Raj Xavier, Sameeullah Sharief, Mohammad Amin, Marcos Turquetti and Pradip Peter Dey</i>	
Framework for Sustainability Practices in Construction Education Curriculum using BIM.....	99
<i>Jin-Lee Kim</i>	
Professional Practice and the Engineering Curriculum	107
<i>Paul M. Jones, J. Richard Phillips</i>	

Practical Lecture, Research, and Projects Based Engineering Education.....	115
<i>Jeffrey Ashworth, Samer Shaghoury</i>	
A Novel Approach to Expose Students to Global Issues in Civil Engineering and Construction Engineering Management.....	124
<i>Antonella Sciortino, Lisa Star, Tesfai Goitom</i>	
Incorporating Field Experiences into Environmental Engineering Lab Courses.....	133
<i>Harmonie A. Hawley, Brian O'Dell</i>	
Encouraging Women to Transfer into Engineering Programs from 2-Year to 4-Year Colleges	140
<i>Lucia Riderer, Harmonie A. Hawley</i>	
Teaching Bioinformatics in Concert: an Interdisciplinary Collaborative Project-based Experience	147
<i>Alex Dekhtyar, Anya L. Goodman, Aldrin Montana</i>	
Analysis of Aerospace Engineering Students Who Repeat Degree Requirements.....	169
<i>David B. Lanning Jr.</i>	
Work In Progress: Teaching Introductory Digital Design Online	184
<i>Bridget Benson, Bryan Mealy</i>	
Academic and Research Cooperation between University of Washington Tacoma and Brazilian Universities	190
<i>Fabricio Braga Soares de Carvalho, Orlando Rocha Baiocchi, Robert Friedman</i>	
Compact International Experiences: Two-year Reflections on Short-term Study-abroad Elective Engineering Courses	195
<i>Frank G. Jacobitz, Thomas F. Schubert</i>	
The Middle East Initiative – Expanding Education in a Global Context.....	207
<i>Liang Li Wu, Anis Hammoudeh, Gregory Washington</i>	
Work in Progress: Using Mastering Engineering Software-Based Homework System in Statics and Circuits Classes	213
<i>Keith Level</i>	
Active Learning in Computer-Aided Engineering Courses (WIP).....	231
<i>Tammy Yut-Ling Chan, Gustavo Borel Menezes</i>	
PolyFS: An Extensible, Underspecified, Pedagogical File System and Disk Emulator	251
<i>Foaad Khosmood, Phillip Nico</i>	
New Technology and Design Methodology for Micromouse: Challenges and Solutions.....	269
<i>Ameneh Akbari, Karla Ananias, Jeffery Bouchard, Qian Wang, George Law</i>	
Retention Strategies for Engineering and Computer Science: High Impact Practices (HIP) during first year in college.....	276
<i>Raman Unnikrishnan, Victor H. Delgado, Hye Sun Moon, Edward Sullivan</i>	
Academic Analysis of an Android Based Student Project: Remote Medical Monitoring Station.....	295
<i>Danyang Li, Qiao Zhen, Albert Gordon, Bhaskar Raj Sinha, Marcos Turquetti, Mohammad N. Amin</i>	

Bringing Design and Construction into Elementary School Classrooms with Sandcastles.....	308
<i>Pamalee Brady, James Guthrie</i>	
Creating Accelerated Educational Pathways for Underprepared STEM Students through an Intensive Math Placement Test Review Program	314
<i>Amelito Enriquez, Denise Hum, Christine Woo, Brandon Price, Danni Redding Lapuz, Anna Camacho</i>	
Ethics in Engineering: Preparing Our Students to Meet Societal Obligations.....	329
<i>Jim Helbling, Angela Beck</i>	
Enhancing Learning Techniques in Undergraduate Mechanical Design Classes	337
<i>Nina Robson</i>	
The Decline of the Car Enthusiasts: Implications for Undergraduate Engineering Education.....	343
<i>M. Cardenas</i>	
Inquiry-Based Learning Activities in Dynamics.....	350
<i>Jeffrey Georgette, Brian Self, James Widmann, Kathryn Bohn, Eric Wang</i>	
Implementation of a Proactive and Effective Advising Program in a Large Civil Engineering Program In the Face of Budgetary and Organizational Constraints.....	364
<i>Seema C. Shah-Fairbank, William Kitch, Kenneth Lamb</i>	
An Innovative Approach to Educating Engineers in Entrepreneurship	376
<i>Nasser Alromaih, Mark Rajai, S. Jimmy Gandhi</i>	
Classical Test Theory Analysis of the Dynamics Concept Inventory.....	390
<i>Natalie Jorion, Brian Self, Katie James, Lianne Schroeder, Lou DiBello, Jim Pellegrino</i>	
<i>CoursePedia</i> for Engineering Courses.....	400
<i>Kiran George</i>	
Summer Research Opportunity for University-Community College-High school Partnership: A Great Motivation for Engineering Education Pathways	405
<i>Binod Tiwari</i>	
Engaging Engineering Students in Research from Early Stage of Their Student Career	412
<i>Binod Tiwari</i>	
Evaluating the Impact of ECS Academic Catalyst for Excellence (ACE) Scholarship Program	416
<i>Kiran George</i>	
Identifying At-Risk Students: How Use of Optional Study Materials and Collection of Graded Work Correlate with Academic Performance	423
<i>Vladimir I. Prodanov</i>	
Increasing Lab Participation and Content Retention through Supportive Laboratory Preparatory Assignments.....	429
<i>Tina Smilkstein</i>	
Protection Considerations for Telecommunications Network	441
<i>Ibraheem A. Kateeb, Khaled F. AlOtaibi, Larry Burton, Michael S. Peluso, Evelyn R. Sowell</i>	

The Fundamental Component of Telecommunications Cabling	452
<i>Ibraheem A. Kateeb, Khaled F. AlOtaibi, Larry Burton, Michael S. Peluso, Evelyn R. Sowell</i>	
Community Attitudes Related to Telecommunications Cables	468
<i>Ibraheem A. Kateeb, Khaled F. AlOtaibi, Larry Burton, Michael S. Peluso, Evelyn R. Sowell</i>	
A Community College Perspective of the Development of Engineering Transfer Model Curricula under the California Student Transfer Achievement Reform Act (SB 1440): An Update on Work in Progress.....	477
<i>Kate Disney, Erik Dunmire, Michelle Millea, Larry Owens, Jo-Ann Panzardi, Liz Rozell</i>	
A Data-Driven Approach to Categorizing the Spatial Organization of Homework Solutions	481
<i>J. Herold, A. Zundel, T. F. Stahovich</i>	
Using a Lexical and Temporal Analysis of Students' Self-Explanation to Predict Understanding	492
<i>Nicholas M. Rhodes, Matthew A. Ung, Jim Herold, Thomas F. Stahovich</i>	
Simple Experiments and 3-D COMSOL Simulations to Enhance the Learning of Transient Heat Transfer	501
<i>Sergio Mendez, Lisa AungYong</i>	
Towards Gender Balance in Engineering for an Expanding Global Market Place.....	511
<i>Muge Mukaddes Darwish, Ali Nejat</i>	
From Step-Response to State-Space Controller-Observer Design in Twenty Minutes: A Hands-On Workshop on the Use of Matlab/Simulink to Control a Low-Cost Aerodynamic Pendulum.....	522
<i>Eniko T. Enikov, Jesus Acosta Iriqui</i>	
Project-Based Innovation and Entrepreneurship Education in Engineering.....	536
<i>R. Radharamanan</i>	
Can Students Build Production-Quality Software?.....	555
<i>Gene Fisher</i>	
Interactive Web Activities for Online STEM Learning Materials.....	561
<i>Alex Edgcomb, Frank Vahid</i>	
Using Arduino Microcontroller Based Robot Projects to Teach Mechatronics in a Hands-On Mechanical Engineering Curriculum.....	570
<i>Andrew Siefert, Jonathan Hoy, Keith Christman, Kevin R. Anderson</i>	
Computer Aided Teaching and Learning in an Undergraduate Electromagnetics Class	583
<i>Milica Marković</i>	
Teaching Introductory Programming Concepts: A Comparison of Scratch and Arduino	604
<i>Anne Beug, Phillip L. Nico</i>	
Professional Development of University Engineering Faculty through a Math-Science Partnership	611
<i>Kurt McMullin, Thalia Anagnos, Jan Hustler, Nancy Thomas</i>	

International Research/education Collaboration on GaN LED/LDs between Cal Poly (USA) and PKU (China)

Xiaomin Jin ^a, Xiao-hua Yu ^a, Xiang-Ning Kang^b, and Guo-Yi Zhang^b

^aElectrical Engineering Department, 1 Grand Avenue,

California Polytechnic State University, San Luis Obispo, CA, USA, 93407-9000;

^bSchool of Physics and State Key Laboratory for Artificial Microstructures and
Mesoscopic Physics, Peking University, Beijing, China, 100871.

Abstract

We initiated and established an international collaboration with institution in China. This is one of the international programs at California Polytechnic state University (Cal Poly) that emphasizes on both research and educational aspects. Our international partner is Professor Guoyi Zhang in the School of Physics at Peking University (PKU), Beijing, China. This project started by the Prof. Jin's summer visit to PKU in 2006 which is supported by Wang Faculty Fellowship at Peking University in Beijing, China, 2006-2007 through California State University (CSU) International Programs, and then expanded to include several teams of Cal Poly students international visit from 2007 to 2012, which was also supported by Department of the Navy, under Award # ONR 6-N00014-07-1-1152 (2008) and Award # ONR 7-N000140811209 (2009); "ChunHui" exchange research fellow through Chinese Educational Department (2008), respectively. In summer 2009, Simeon Trieu, one of Prof. Jin's graduate students, was awarded an NSF EAPSI summer and won the 1st place CSU research competition on graduate engineering and computer engineering level in 2010, because of working on the project. Now Prof. Jin is supported by 1) NSF Grant OISE Award #1029135 from year 2010 to 2013 and 2) Chinese National Key Research Lab Collaboration Grant 2010-2011 and 2011-2012. Those grants enable Prof. Jin to bring more US students to work in China. This paper will discuss how those activities are running in the past years and what the key issues of the program are. The paper also emphasizes participates (students and faculty) learning outcome in both technical aspect and culture aspect.

1. Introduction

Because of internet and www, the world shrinks. With the rapid technology development, globalization, and intensified competition, to make the business transition smooth, there is an urgent need for our engineers, engineering students, and instructors to have direct interaction with their international counterparts. A direct solution is for us to establish collaboration among faculties and students between U.S. and overseas partners.

We initiated and established an international collaboration with institution in China. This is one of the international programs that emphasizes on both research and educational aspects. This project started by the Prof. Jin's summer visit to Peking University (PKU), Beijing, China in 2006 which is supported by Wang Faculty Fellowship at Peking University in Beijing, China, 2006-2007 through California State University (CSU) International Programs, and then expanded to include several teams of Cal Poly students international visit from 2007 to 2012,

which was also supported by Department of the Navy, under Award # ONR 6-N00014-07-1-1152 (2008) and Award # ONR 7-N000140811209 (2009); “ChunHui” exchange research fellow through Chinese Educational Department (2008), and NSF Grant OISE Award #1029135 from year 2010 to 2013, respectively. In summer 2009, Simeon Trieu, one of Prof. Jin’s graduate students, was awarded an NSF EAPSI summer and he also won the 1st place CSU research competition on graduate engineering and computer engineering level in 2010, because of working on the project. Now Prof. Jin is supported by 1) NSF Grant OISE Award #1029135 from year 2010 to 2013 and 2) Chinese National Key Research Lab Collaboration Grant 2010-2011 and 2011-2012. Those grants enable the Prof. Jin to bring more US students to work in China. Since 2012, our new goal is to let students in both countries to freely choose their research topics and their advisers. This paper will discuss how those activities are running in the past years and what the key issues of the program are. The paper also emphasizes participates (students and faculty) learning outcome in both technical aspect and culture aspect.

2. Project Activity

Cal Poly professors visit Peking University/Tsinghua University every summer to co-develop new LED structures since 2006. Our Cal Poly team is focus on design and validation, while Peking University/Tsinghua University is in charge of fabrication. Cal Poly provides and discusses LED design rules for China Partners. In the earlier years, our joint research team is very productive and brings a lot of publication in LD/LED development.

In summary, there are three stages of our activities:

1) From 2006 to 2008, we emphasized on faculty visits to establish a trust between the PI and Chinese partners, which was supported by Wang Faculty Fellowship through CSU International Programs (2006-2007); Department of the Navy, Office of Naval Research, under Award # ONR 6-N00014-07-1-1152 (2008) and Award # ONR 7-N000140811209 (2009); “ChunHui” exchange research fellow, Educational Department, China (2008), respectively.

2) Cal Poly students' summer visits to PKU (2009 - 2013) to enhance their graduated/undergraduate education, which is supported by NSF Grant: OISE Award #1029135 (2010 - 2013). Fig. 1(a) shows our students work at PKU and discuss simulation model for the devices with graduate students in Beijing China and Fig. 1(b) shows that Cal Poly and PKU students and faculty are working in the clean room. Fig. 2 shows Professor Bei Zhang from PKU visiting Cal Poly.

3) In 2012, we developed a Virtual International Research/Education Center on Energy Saving Light Emitting Diodes (LEDs) in Beijing.



(a)



(b)

Fig. 1(a) Cal Poly students work at PKU and discuss simulation model with PKU graduate students in Beijing, China and (b) Cal Poly and PKU students and faculty are working in the clean room.



(a)



(b)

Fig. 2 Prof. Bei Zhang (a) from PKU visit Cal Poly in 2011 and (b) discuss GaN LD/LED reach with Cal Poly professors and students in San Luis Obispo, USA.

3. Description of Collaboration Teams

Peking University (PKU) founded in 1898 and was the first national comprehensive university in China. The Research Center of Wide Gap Semiconductor (RCWGS) of PKU is multidiscipline research center established in 2001. It is in the frontier of wide gap semiconductor research. **Prof. GUOYI ZHANG** is a professor in the School of Physics and Director of the Research Center for Wide-band Gap Semiconductors, Peking University, China. His research focuses on MOCVD techniques and GaN-based materials and devices. His recent research projects include GaN short wave length laser diodes, GaMnN dilute semiconductor, and polarized LEDs.

California Polytechnic State University (Cal Poly) is one of the 23 campuses making up the California State University system. Cal Poly is one of the largest undergraduate teaching institutes (non-PhD program) in USA and offers programs in engineering, science, business, and liberal arts. To prepare our students with the most advanced technology, most of our faculty is actively involved in advanced research, especially those in the college of engineering. The collaboration with PKU and Tsinghua University is certainly moving us one step further in that direction. **Prof. Xiaomin Jin** has strong photonic device measurement and simulation capability due to previous projects. She graduated from Tsinghua University with B.E and MS in 1992 and 1996. And she received her Ph.D. from University of Illinois at Urbana-Champaign in 2001. Now she is an associate professor of EE department at Cal Poly. Overall she has twenty years of research experience in areas of photonics and fiber optic communication.

Cal Poly and PKU both have advantages in terms of facilities necessary for this project. The students at Cal Poly are strong in terms of employing different software models to perform simulations. The research group, led by Dr. Jin at Cal Poly, acquired several cutting-edge simulation packages over the past years, which made the detailed modeling and simulation possible. The group in PKU led by Prof. Zhang is strong in fabrication and characterization of LEDs. In fact, as well-funded research universities, PKU possesses advanced fabrication and characterization facilities that are not available at Cal Poly. The main fabrication center will still be in the Research Center of Wide Gap Semiconductor (RCWGS) of Peking University. The main simulation center will be located at Cal Poly, USA.

4. Technical work and Collaboration

In this section, we use GaN LD/LED research as examples for detail technical collaboration. With the demand to develop energy efficient, bright, and green light sources, intensive research efforts have been made on the studies of light emitting diodes (LEDs). LEDs can be used in many applications, such as solid state lighting, photonics, display technology, and machine vision. To meet the needs of these applications, light sources must be able to achieve high luminosity with minimal amount of heat generated at low power. The key limitation for light emissive devices is the light trapping due to the device layers' low critical angle. The majority of the light generated has few angles of escape and is reflected back within the device instead of escaping. The solution of above problem is the following: the emission surface can be patterned with a transmission diffraction grating that allows more angles of escape via Bragg diffraction. Incident light at the surface would be scattered at the emission surface instead of being simply transmitted or reflected. In addition, it has been shown that the same patterning can also apply to

the Ag reflector plate, commonly used to reflect the light escaping at the bottom of the device towards the top emission surface [1], [2]. The second device inefficiency is due to absorption by defects in the GaN crystal or by the highly absorbent multiple quantum well layers that light waves must eventually pass through if reflected at the emission surface. When light encounters a defect or the quantum well layers, it will be absorbed instead of being transmitted at the surface. This is a critical aspect of light extraction efficiency, not only because the photon cannot escape the device, and therefore cannot add to device luminosity, but also because the absorbed photon transfers its optical energy into a phonon or lattice vibration, thereby generating heat within the semiconductor. So, it is critical that photons are extracted in greater quantity and speed before recombination occurs [3], [4]. A diffraction grating will again relieve this issue via Bragg diffraction.

The device model is a key issue in opto-electronic device research. Grating structures can be patterned with many shapes including: pyramidal, spherical, conical, cylindrical, and so on, but only a few can be feasibly fabricated with great success. It is very expensive to fabricate different photonic devices and make direct comparisons. We first fabricate some basic devices and test them (performed at Peking University or PKU). Then, we use the experimental data and create device models which match the experimental data. We then vary the device structure in our model and find the optimized design for the photonic device and provide feedback to PKU. The device model will allow intelligent device selection, modification, and optimization of device design/performance.

At beginning, in 2006, Prof. Jin used a simple rigorous couple wave analysis (RCWA) analytical method to study top grating structure, which was published in [5, 6]. RCWA can only simulate periodic grating structures at one interface and cannot study grating performance inside devices. In summer 2008, Dr. Jin visited PKU to improve the project and decided to use the Finite Difference Time Domain (FDTD) method for this grating study, which in principle can simulate any grating structure and its effects on LED light extraction. Prof. Jin first developed the FDTD single reflection grating study. The transmission top grating simulation results were summarized and published. Her current research is focus on top, bottom, and top-bottom grating simulation for maximum light extraction efficiency of GaN LEDs using the FDTD method. The FDTD reflection grating simulation was compared to and agreed with experimental data provided by Peking University [7] [8]. The top-bottom (or transmission-reflection) grating results are also studied. This direct comparison of 181 different combined top-bottom grating cases using the FDTD method is presented for the first time [9]. Etching a structure on the extraction surface and/or on the bottom reflection surface commonly solves the light trapping issue. The single grating simulation has been studied intensively already. However, it is novel to present effects of top gratings, bottom gratings, and combinations of both using FDTD theory. It is also not practical to fabricate all the grating cases and obtain the optimization rules and trends. Even our calculation here is only limited to one particular GaN LED structure developed by PKU [7, 10]. Moreover, in fabrication, etching involves defects; the grating structure is not a perfectly periodic crystal. Finally, transmission-reflection error grating models are also presented. Randomization in grating design and its effects in fabrication are also presented for the first time [9]. We develop an error grating model to study the effects of the fabrication randomization. We published 1st paper on the error grating model of the top-bottom grating structures. In the last two years, we intensively study top, bottom, and top-bottom nano-grating simulation for

maximum light extraction efficiency from Gallium nitride (GaN) LEDs using the Finite Difference Time Domain (FDTD) method [11][12][13].

5. Outcome

The work distribution between U.S. students and Chinese students was clear, yet closely related. US students focused on device simulation, and Chinese students worked on GaN device fabrication. Exchanging results was necessary for progress on both sides, which encouraged them to actively communicate with each other. The result of this collaboration was successful from both a research and education point of view. We published more than 15 technical papers in the past years. Student comments on both sides confirm that they obtained a better understanding about foreign cultures and that they thought it was helpful for them if they chose to pursue a career in a multinational firm.

There are a lot of key elements or advantages of the projects. Here we list some of those [14]:

- **Trust Building/Global Friendship:** The leaders of the project should have trust and understanding. The students in both countries are also building up their friendship. One of US students even find Chinese wife.
- **Regular communication and teamwork:** Frequently holding teleconferences with the entire group (including both U.S. and Chinese teams) is important for both students and faculty to connect with each other, not only on technical issues, but also on working habits and culture differences.
- **Management skill:** The management skill of the professors from both sides is critical throughout the project. Research work needs to be distributed based on each party's strength. In our case, Cal Poly possesses an advanced design environment, and PKU has cutting-edge fabrication clean rooms. Therefore, Cal Poly is in charge of design validation and improvements, while PKU is in charge of design realization and testing.
- **Mutually beneficial topics:** This is an important motivation for the project. Good research topics and project goals should be carefully selected by professors from both sides. Complementary capabilities of both sides will produce mutual benefits for the research and strengthen collaboration in the future.
- **Financial independence:** It is difficult to receive funding from other countries. We decided to fund research independently. We are in charge of software development funding, and PKU funds their fabrication facility. As for the research visits, the sending country pays the international airfare, while the host country pays for the expenses related to a short visit.
- **Low financial burden on the students from both sides:** For some students, spending a period abroad is costly. Students also have to plan carefully to make their curriculum flexible enough to allow them to be away long term and not fall behind in other courses. Our project allows the students to get international experience without having to deal with interruptions in their regular course sequence. The short international visit is only an option and enhancement of the collaboration, but it is not a necessary component.
- **Data accessibility around the world (spontaneous global communities):** The development of computers, the Internet, the World Wide Web (WWW), and fiber optical communication systems transforms international research and education into a global scientific enterprise. The current technology allows the formation of spontaneous, international learning communities. We can share information in textual, graphic, and multimedia formats across the

world. This shrinking world provides our students a low-cost international education environment. It can be called “Spontaneous global communities.”

- **The consciousness of foreign countries:** The consciousness of foreign countries is improved throughout the project, which also improves U.S. students’ global understanding.
- **International co-authorship for the research results:** This is an important outcome of the international educational and research partnerships.
- **English/Chinese learning community:** English is the basic language for communication. However, U.S. students are also interested in learning a little Chinese besides research. Chinese students are also offered an unusual learning opportunity of presenting and defending their projects using technical English terminology. Students from both sides are working toward eliminating the linguistic barrier.

6. Conclusion

Previously, because of the lack of communication, international professional groups working on similar research projects did not exchange ideas before publishing their research results. Therefore, some of the research was developed redundantly, which wasted resources. The development of telecommunication in the past decade opened unprecedented opportunities for international scholars. Researchers, leading student-scholar teams around the world, can use each other’s knowledge and work together on a project in a timely fashion, leading to what we call international research and education collaboration. However, there are no universal models for international collaboration. Each case has a unique character. In our project, researchers in Cal Poly and PKU are involved in these activities. Communication between faculty advisors and students on all sides is important to the success of this project. We also hold annual meeting for the collaboration to exchange ideas both on research and culture.

Acknowledgement

This project is currently supported by 1) NSF Grant OSIE Award #1029135 from year 2010 to 2013 2) Chinese National Key Research Lab Collaboration Grant 2011, 2012, Peking University in China.

Reference

1. J. Q. Xi, H. Luo, A. J. Pasquale, J. K. Kim, E. F. Schubert, “Enhanced Light Extraction in GaInN Light-Emitting Diode with Pyramid Reflector,” *IEEE Phot. Tech. Lett.*, vol. 18, pp. 2347-2349, 2006.
2. S. Trieu, X. Jin, B. Zhang, T. Dai, K. Bao, X. N. Kang, G. Y. Zhang, “Light Extraction Improvement of GaN-based Light Emitting Diodes using Patterned Undoped GaN Bottom Reflection Gratings,” *Proc. SPIE.*, Vol. 7216, pp. 72162Q-72162Q-8, 2009.
3. T. X. Lee, C. Y. Lin, S. H. Ma, C. C. Sun, “Analysis of position-dependent light extraction of GaN-based LEDs,” *Optics Express*, vol. 13, pp. 4175-4179, 2005.
4. Y. A. Chen, N. Y. Liang, L. H. Lai, W. C. Tsay, M. N. Chang, J. W. Hong, “Improvement of electroluminescence characteristics of porous silicon LED by using amorphous silicon layers,” *Elec. Lett.*, vol. 33, pp. 1489-1490, 1997.
5. X. Jin, B. Zhang, T. Dai, W. Wei, X. N. Kang, G. Y. Zhang, S. Trieu, F. Wang, “Optimization of top polymer gratings to improve GaN LEDs light transmission,” *Chinese Opt. Lett.*, vol. 6, pp. 788-790, 2008.

6. X. Jin, S. Trieu, Fei Wang, B. Zhang, T. Dai, X. N. Kang, and G. Y. Zhang, "Design Simulation of Top ITO Gratings to Improve Light Transmission for Gallium Nitride LEDs", 2009 Sixth International Conference on Information Technology: New Generations, ITNG2009, Las Vegas, Nevada, USA, April 27-29, 2009.
7. K. Bao, X. N. Kang, B. Zhang, T. Dai, C. Xiong, H. Ji, G. Y. Zhang, Y. Chen, "Improvement of Light Extraction from Patterned Polymer Encapsulated GaN-Based Flip-Chip Light-Emitting Diodes by Imprinting," IEEE Phot. Tech. Lett., vol. 19, pp. 1840-1842, 2007.
8. S. Trieu, X. Jin, C. Xiong, X. X. Fu, X. Kang, G. Y. Zhang, B. Zhang, F. Wang, "Simulation and Experiment on 2PC Transmitted Diffraction Grating for GaN LEDs" Nanotech 2010, June 2010, Anaheim, CA.
9. S. Trieu and X. Jin, "Study of Top and Bottom Photonic Gratings on GaN LED with Error Grating Models," IEEE J. Quantum Electon., Vol.46, no. 10, pp.1456-1469, 2010.
10. K. Bao, X. Kang, B. Zhang, T. Dai, Y. Sun, Q. Fu, G. Lian, G. Xiong, G. Zhang, Y. Chen, "Improvement of light extraction from GaN-based thin-film light-emitting diodes by patterning undoped GaN using modified laser lift-off," Appl. Phys. Lett., vol. 92, 141104, 2008.
11. Douglas Alan Cattarusaa, X. Jin, Xing-Xing Fu, Xiang-Ning Kang, Bei Zhang, and Guo-Yi Zhang, "Optical-Mode Study of Galium Nitrate Based Laser Diodes," Advanced Materials Research, Vol. 571, pp 476-481, 2012.
12. Greg Chavoor, Doug Cattarusa, Xiaomin Jin, Xing-Xing Fu, Xiang-Ning Kang, Bei Zhang, and Guo-Yi Zhang, "Optical Mode Pattern Study of GaN LEDs with and without Top Nano-Gratings", The SPIE Photonic West 2012, the Moscone Center, San Francisco, CA, January 21-26, 2012.
13. Greg Chavoor, Xiaomin Jin, Ashton Ellaboudy, Xing-Xing Fu, Xiang-Ning Kang, Bei Zhang, and Guo-Yi Zhang, "Light Extraction Improvement of GaN LEDs using Nano-scale Top Transmission Gratings", The SPIE Optical Engineering + Applications, 21-25 August 2011 in San Diego, California , 2011.
14. X. Jin, B. Zhang, F. Wang, J. Flickinger, S. Jobe, T. Dai, G.Y. Zhang, "International Engineering Research and Educational Activity on GaN Lasers and LEDs", International Journal of Engineering Research and Innovation (IJERI), Vol. 1, No. 1, P5, Spring/Summer 2009.

Engaging Community College Students in Research using Summer Internship on Analysis of Performance Degradation of Integrated Circuits Due to Transistor Aging Effects in Nano-Scale

John Paulino¹, Jesus Garcia¹, Joshua Lohse¹, Hector Prado¹, Atul Balani², Sridevi Laksh mipuram², Cheng Chen², Amelito G. Enriquez¹, Hao Jiang², Hamid Mahmoodi², Wenshen Pong², Hamid Shanasser²

¹Cañada College, Redwood City, CA/ ²School of Engineering, San Francisco State University, San Francisco, CA

Abstract

Integrated Circuits, or ICs, work behind the scenes to make people's lives better from common appliances, such as refrigerators and dish-washers, to the most sophisticated computers. IC performance has dramatically improved since their first creation. However, with scaling of ICs to Nano-scale, an ideal integrated circuit delivering reliable performance over its lifetime is almost impossible. All ICs experience degradation over time due to the aging of underlying transistors. Working on latest technology issues is typically an opportunity available only to graduate level students working on related research projects. To address this gap, using a NASA Curriculum Improvements Partnership Award for the Integration of Research (CIPAIR) grant, we have created a summer internship program that engages community college students in research projects on the latest challenges of circuit design in nano-scale semiconductor technology. Through this program, four community college students were mentored by two graduate students in a research project to analyze performance degradation of integrated circuits due to transistor aging effects in nano-scale. In this research, analysis of transistor breakdown is performed through computer simulations using the Custom Designer SE tool to understand effects on circuit power and performance. To simulate the effect of transistor breakdown, a ring oscillator circuit is utilized. This breakdown is modeled by resistors placed between the transistor terminals. The values of the resistors represent the severity of breakdown; large resistors represent fresh transistors, whereas low resistors represent a fully broken transistor. In addition to computer simulations, real ICs are studied by taking power measurements. This research aims to offer better insight into the impact of transistor breakdown and to improve IC design in Nano-scale.

I. INTRODUCTION

It is difficult to imagine life without integrated circuits because many aspects of civilization have become dependent upon them. The supercomputers, high-tech machines, and cutting-edge technology of today would not be possible without a simple switch known as the transistor. It is unbelievable how much IC technology improved in such a short time; the first IC had two transistors, but today's computers typically exceed a billion transistors. However,

designing more reliable, energy efficient, and high performing ICs in nanotechnology presents many difficulties. As transistor channels continue to shrink for better performance, problems such as transistor breakdown and instability arise and challenge today's computer scientists and engineers. It is important to study and prevent IC breakdown in order to continue technological growth.

Transistors have two main attributes: a high speed switch and an amplifier. The most simple model of a transistor is a faucet which can be turned on or off by a valve. In the case of digital circuits, transistors are either on or off with a delay in between the switching. As the size of transistors decreases, this delay decreases due to the time to activate.

Circuit designers and testers commonly use a circuit called a ring oscillator (RO), as shown in Fig. 1, to test new technology and reliability. ROs are created using an odd number of Complimentary Metal-Oxide Semiconductor (CMOS) Inverters because an even number of inverters will not allow the signal to oscillate. The output signal of the last inverter or stage is connected to the input signal of the first inverter forming a "ring".

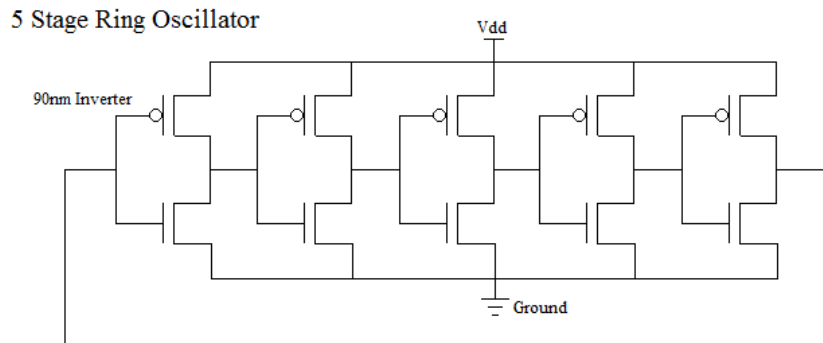

Figure 1. Schematic for 5 Stage Ring Oscillator

Each inverter is composed of two Metal-Oxide Semiconductor Field-Effect Transistors (MOSFETS), which act as capacitors [1]. The inverter is the most fundamental construct of digital circuits. Its job is to take an incoming pulse and convert it to either high voltage or zero. This means that if a pulse has amplitude of 1.2V, the output of the inverter will be zero, or if the pulse has amplitude of zero, the output will be 1.2V.

When the RO is started with alternating potentials of high and zero volts at nodes between inverters, the signal starts to oscillate. The signal frequency is dependent on the transistor technology but most notably on the number of stages. Frequency and the number of stages are inversely proportional, so as the number of stages increases, the frequency of oscillation decreases.

All integrated circuits will experience degradation which can come in many forms. Soft Oxide Breakdown (SBD) is a type of degradation that involves the formation of traps in the gate oxide layer of the transistor. These traps, which are defects in the SiO_2 gate oxide, form conduction paths and develop leakage current from the polysilicon gate to the silicon substrate, as shown in Fig. 2. The leakage current affects the power consumption of the circuit even during its off state. There is debate about the formation of traps which includes: fabrication issues, hole creation, proton release, irradiation, and thermal damage [2].

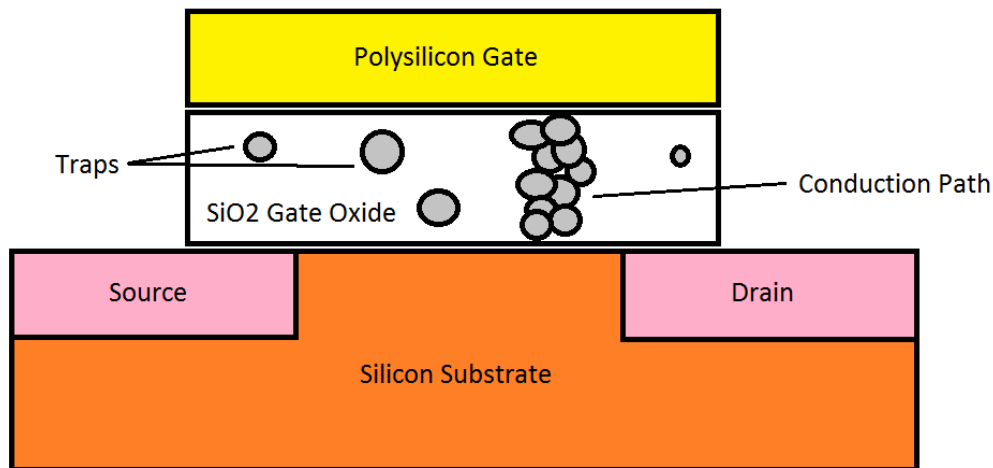

Figure 2. Cross Section of NMOS transistor showing traps and conduction path in the gate oxide region

Oxide breakdown has been investigated for various purposes, ranging from early-life failure (ELF), to the effect that breakdown has on performance of circuits [3 4]. Nan et al. analyzed the delay caused by SBD on a single gate of an inverter [4]. They used 32nm transistor technology, with a 0.9V supply voltage, and a constant resistance value of 100k Ω to model SBD. However, their work did not include a wider range of resistance values to better understand the effects of SBD on the performance of the circuit. As such, they were unable to see the decrease in performance up until the point that hard breakdown (HBD) occurs.

Working on latest technology issues is typically an opportunity available only to graduate level students working on related research projects. To address this education gap, using a NASA Curriculum Improvements Partnership Award for the Integration of Research (CIPAIR) grant,

we created a summer internship program to engage community college students in research projects on the latest challenges of circuit design in nano-scale semiconductor technology. Through this program, four community college students were mentored by two graduate students in a research project to analyze performance degradation of integrated circuits due to transistor aging effects in nano-scale. This paper presents the research conducted by these students on establish how SBD affects the performance of a circuit, specifically the delay variation and power consumption, in relation to location of the breakdown, and its severity.

II. APPROACH

The effects of leakage current through the transistors of integrated circuits are simulated by inserting a resistor into the RO circuit. Failures in the inverter can occur at four different locations, as shown in Fig. 3: NMOS/PMOS gate to source and NMOS/PMOS gate-to-drain. These failures are modeled by placing resistors at these locations one at a time. The values of the resistors determine the severity of the circuit degradation. It is expected that as this value decreases, the performance degrades proportionally.

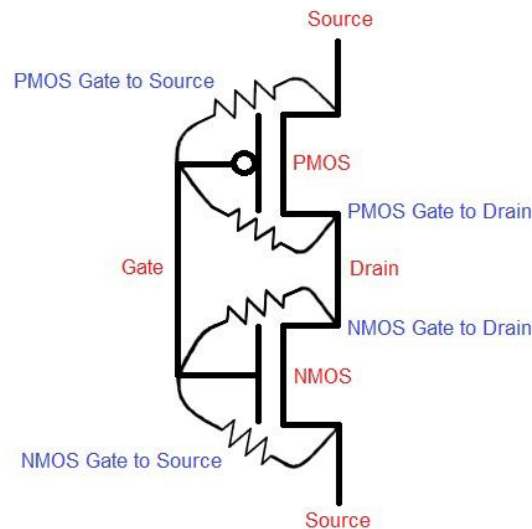

Figure 3. Locations of Leakage Resistors in the Ring Oscillator

SBD in logic circuits can be modeled by replacing multiple different logic gates in a specific path with a ring oscillator. This ring oscillator contains one inverter that contains a resistor at one of the four locations whose value varies from $1\text{M}\Omega$ down to $1\text{k}\Omega$. Three, five and seven stage ring oscillators are used to see if the effect of the inverter with SBD diminishes with

length. All of these circuits were created in Synopsys Galaxy Custom Designer and simulated using HSPICE.

Data on frequency, period, delay and average current were collected using measurement tools inside the WaveView software. Delay values were calculated by averaging the rise and the fall delays at 50% of maximum voltage as shown in Fig. 4. These delay values were only taken for the inverter that has SBD to compare to a fresh inverter. Each one of the variables had multiple values recorded and averaged to form the final tables and graphs.

An actual IC is analyzed using Cascade B11000 Probe Station and Agilent B1500A Device Parameter Analyzer. The Cascade B11000 probes the ICs and the Agilent B1500A records and analyzes data.

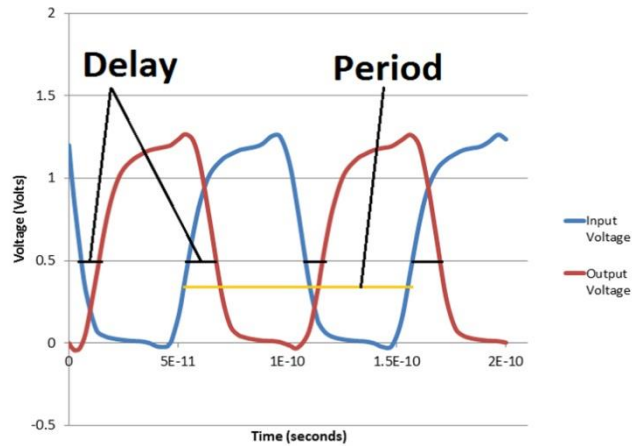

Figure 4. Delay, period, and frequency measurements

III. RELATIONSHIP BETWEEN LEAKAGE RESISTANCE AND TIME

Although the study provides valuable insight as to how ICs will break down, it does not indicate when breakdown will occur. It is important to understand when ICs will cease to work properly in order to improve the ways they are designed and manufactured. According to Afzal et al. [5], the relationship between Soft Breakdown Resistance R_{SBD} and time can be modeled by

$$R_{SBD} = \frac{V_{dd}}{I_0} \exp(-tGR) \quad (1)$$

where V_{dd} is the supply voltage, I_0 is the Initial leakage or defect current, and GR is the defect current growth rate. GR can be computed using the equation

$$GR = K_1 \exp(\theta_1 V_g - \theta_2 T_{ox}), \quad (2)$$

where V_g is gate stress voltage, T_{ox} is gate oxide thickness, and θ_1 , θ_2 , and K_1 are constants from experimental data.

Different values for GR are used: 1.6, 3.2, and $6.4 \times 10^{-8} \text{s}^{-1}$. These constant values are used because no industrial data are available for GR [5]. There are many proposed methods to calculate the initial defect current, I_0 . A voltage source was attached to an NMOS transistor, and it was observed the current that flows through the power source, which is also I_0 , as shown in Fig. 5.

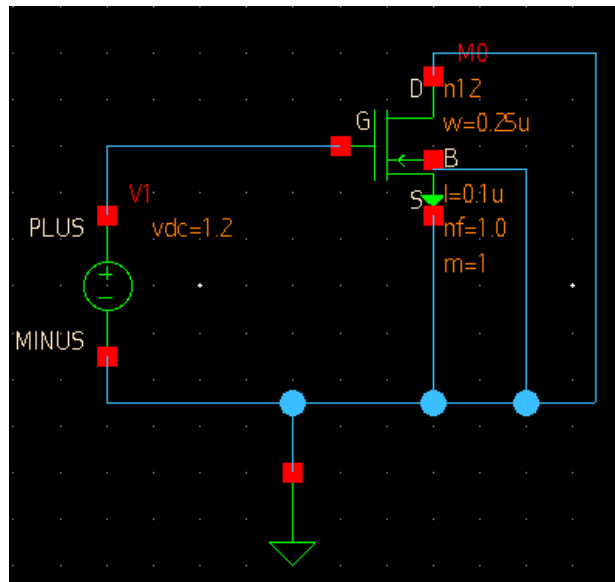

Figure 5. Set-up used to determine I_0

The current coming from the power supply behaves in an oscillating fashion. We use its average as our initial defect current, which is found to be **2.76 nA**. Using the average defect current and 1.2V for V_{dd} , we are able to use Eq. 1 to create a plot that relates resistance and time, which is shown in Fig. 6. The value GR is an inherent characteristic of the circuit; hence, the lowest GR value represents a circuit with a very short life span, and the highest GR value represents a very durable circuit. It is also observed that the leakage resistance does not decrease linearly over time. Rather, it experiences exponential decay.

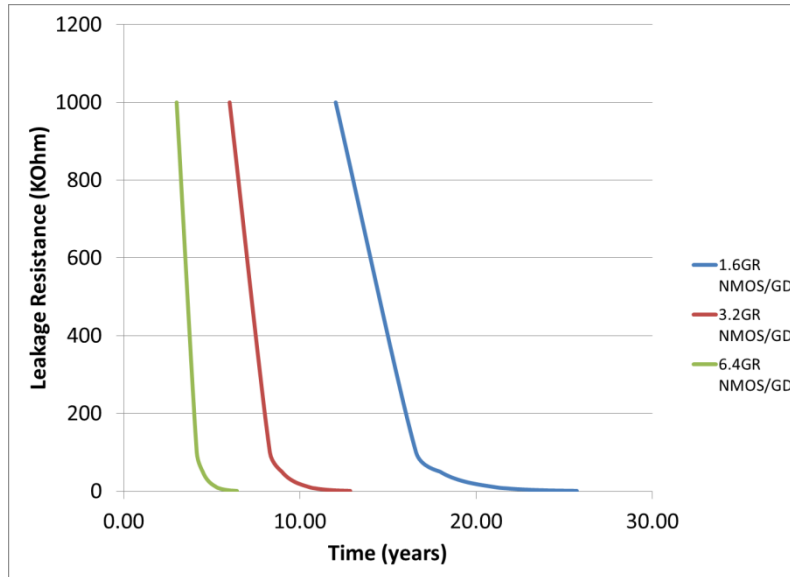

Figure 6. Leakage Resistance vs. Time for various GR values

IV. DELAY RESULTS AND ANALYSIS

A. NMOS/PMOS Gate-to-Source

The results shown in Fig. 7, from the three ring oscillator circuits with NMOS Gate to Source breakdown, show no perceptible difference in delay up to the 10 kΩ average life limit. The measurements show an average change of 1-2 ps in period which is an insignificant change in performance. This difference is not enough to cause the calculation to be completed after the clock cycle because it falls within a minimum clock error of 10 ps.

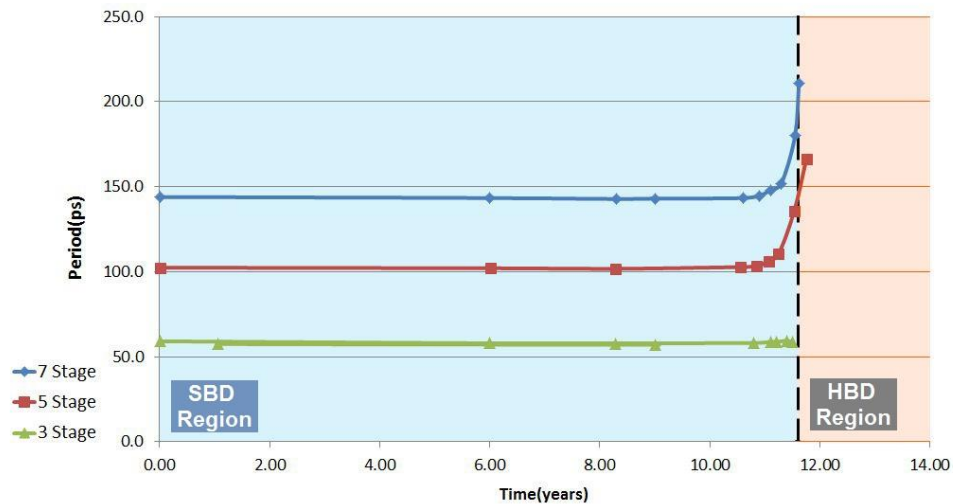

Figure 7. NMOS Gate-to-Source Period vs. Time

*Proceedings of the 2013 American Society for Engineering Education Pacific Southwest Conference
Copyright © 2013, American Society for Engineering Education*

Significant differences occur when the inverter is close to HBD at about 3-4 k Ω , which causes the circuit to fail completely. These failures correspond to about 11-12 years of use, which is more than double the time a typical consumer will use a device.

Delay at the level of the single inverter has increased significantly, but as the number of stages increase, the effect diminishes quickly as shown in Fig. 8. The increase may be critical when a circuit has aged evenly where all transistors have had breakdown. If a main path in a logic circuit were to undergo even SBD, the cumulative effects would be significant enough to cause problems with calculations falling outside of the clock error. Further study is required to see how overall delay or period increases with the addition of more inverters with breakdown.

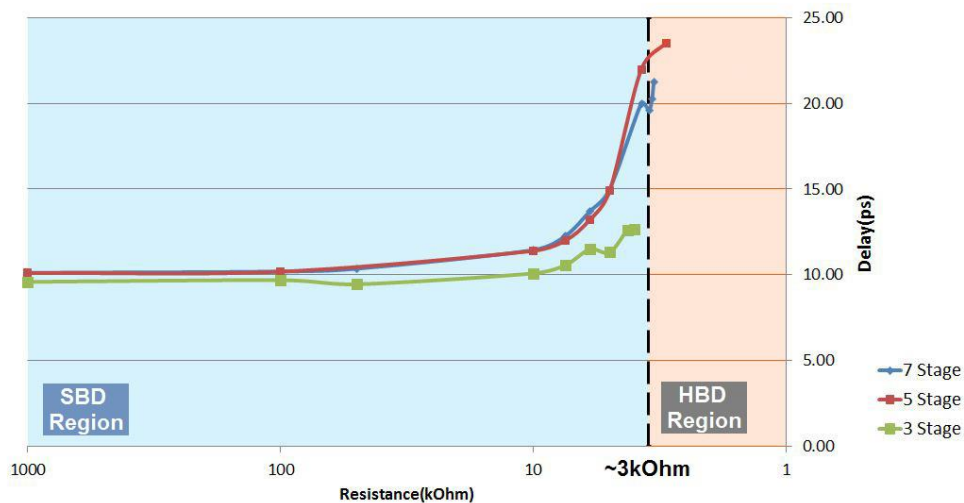

Figure 8. NMOS Gate-to-Source Delay vs. Resistance

According to Choudhury et al. [6], PMOS breakdowns are less likely to be seen because the time to breakdown is one order of magnitude greater than that of the NMOS. The delays, frequencies, and power are very similar to the NMOS as shown in Figs. 7 and 8, so it is believed that further study should be focused on the NMOS failure.

NMOS/PMOS gate to source results can be explained with an analog circuit shown in Fig 9. As the pulse train enters the inverter, shown as current source, some of the current flows to the capacitor but some also flows through the resistor to ground. This causes an increased delay in the charging of the capacitor, which means the rise and fall delays of the waveforms increase. In short, as the resistance decreases the delay increases so the frequency decreases proportionally.

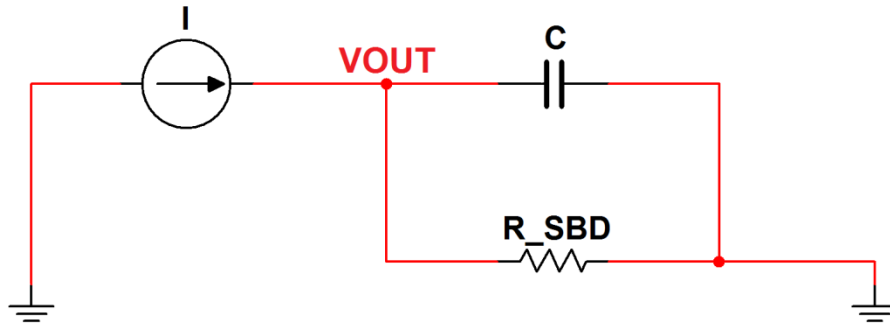

Figure 9. NMOS/PMOS gate-to-source model

B. NMOS/PMOS Gate-to-Drain

Since PMOS and NMOS gate-to-drain yielded identical results due to resistors being connected to same nodes, data for both cases were combined. The three simulations show that an increase in performance is possible when a gate-to-drain breakdown occurs as Table 1. It shows the period on average decreases by 8%. This most likely should not be the focus of future research because it does not negatively affect the circuit.

90nm Ring Oscillator – NMOS/PMOS Gate-to-Drain				
Type	Period(No SBD)	Period(10k Ohm)	Difference	% Difference
3 Stage	59	52	7	11.9
5 Stage	102	97	5	4.90
7 Stage	144	132	12	8.33

Table 1. NMOS/PMOS difference between fresh oscillator and one with single breakdown

Delay of the single affected inverter shown in Fig. 10 does show increase in performance because of the decrease in delay. The change in delay is similar to gate to source, but it seems to have a larger effect on the overall circuit as shown by the period.

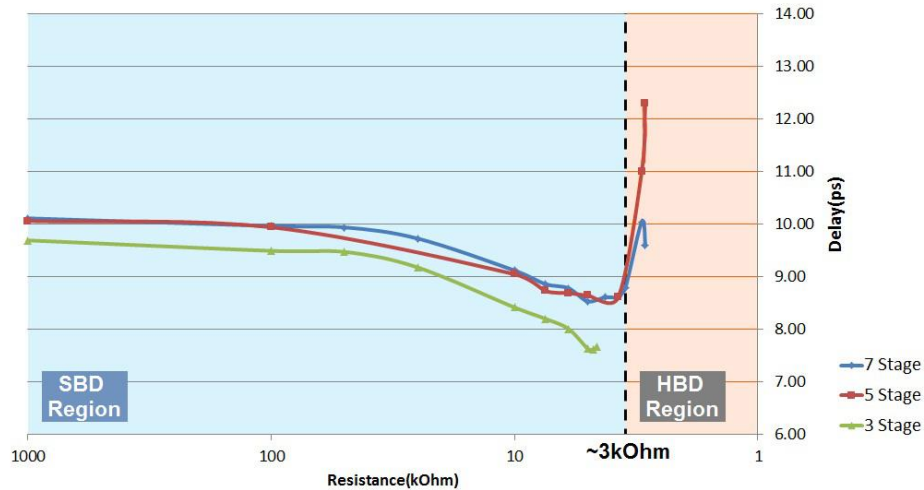

Figure 10. NMOS/PMOS Gate-to-Drain Delay vs. Resistance

The data for the gate-to-drain simulations can be explained with a simpler analog circuit shown in Fig 11. Initially the inverter is turned on, thus a current I_P flows through the resistor helping to charge the capacitor, so $I_C = I + I_P$. I_P switches direction when the inverter switches which slows the charging of the capacitor, thus $I_C = I - I_P$. Large values of R_{SBD} show that the first case is stronger than the second because the delay decreases. As the value decreases close to 5 k Ω , the second case overtakes the first so delay increases rapidly.

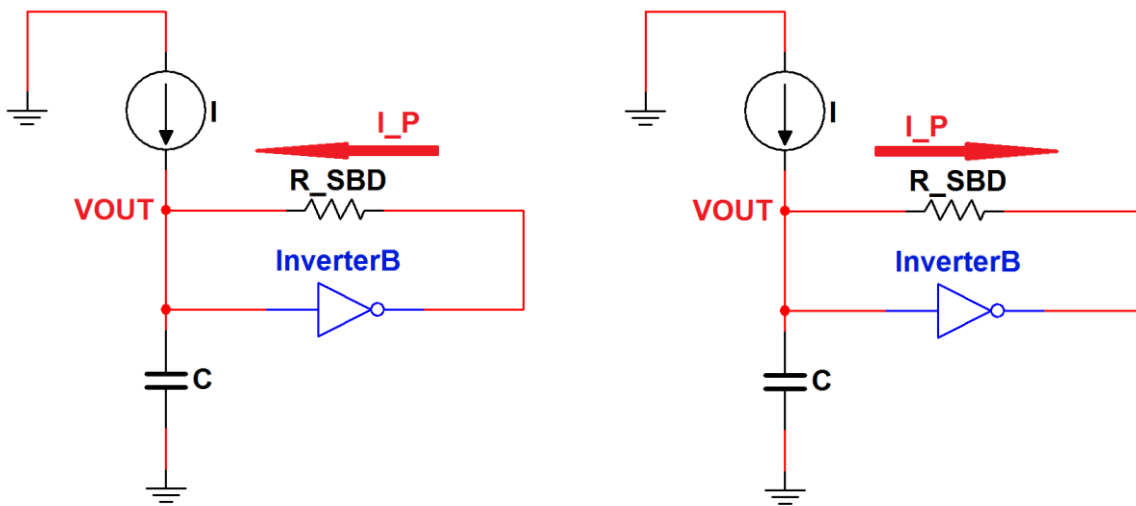

Figure 11. NMOS/PMOS gate-to-drain model, current helping charge (left), resistor taking current (right)

C. Unexpected Results

The three stage results for all of the resistor positions show some unexpected results. The waveforms appear to be damped because they oscillate until their amplitudes reach zero after a short period of time of about 0.5 ns. The frequency and period data remain relatively flat until the breakdown point, which was unexpected because it was believed that the shorter ring oscillator would accentuate the delay differences. We were expecting to still see the rise or drop of frequency, period, and delay that was seen with the seven and five stage ROs.

An interesting difference between the three ring oscillator results seems to be the time when hard breakdown occurs. The exponential increase in period appears to come sooner when the number of inverters increases, such as from five to seven stages. Further study may be needed to see if this is true for circuits longer than seven stages.

V. POWER RESULTS AND ANALYSIS

A. Gate-to-Source

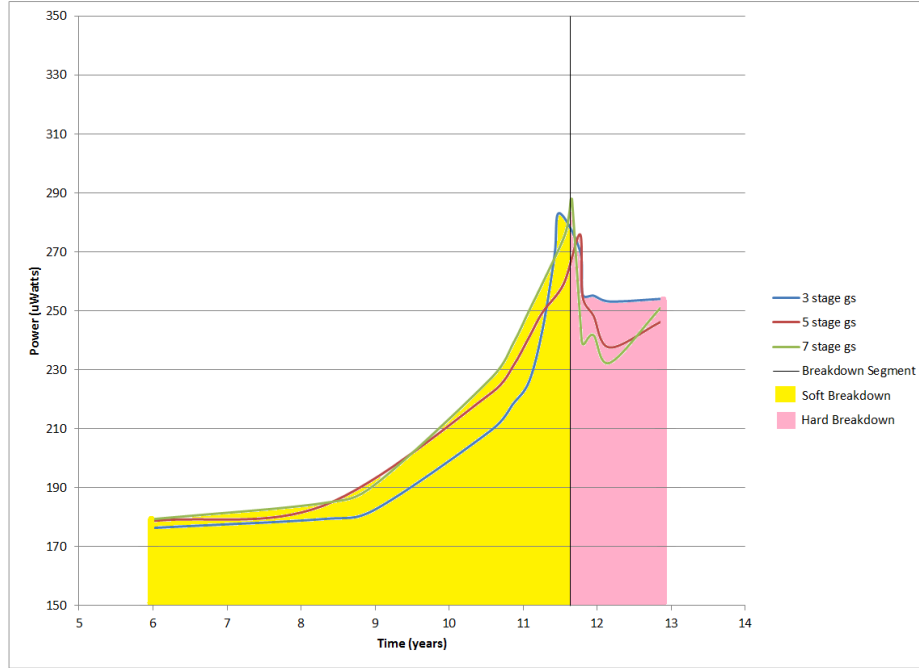

Figure 12. Power vs. Time for Gate-to-Source Breakdown

$$P_{total} = P_{sw} + P_{leakage} \quad (3)$$

The total power consumption for breakdown that occurs in the Gate-to-Source (GS) region can be modeled by Eq. 3. The switching power P_{sw} is the power consumed by the inverter as it switches signals. The transistors in the inverter act as capacitors, so there is a finite time for them to be fully charged and invert the input signal. This charging sequence is one of the reasons for the dissipation of power.

$$P_{sw} = f * C * V_{dd}^2 \quad (4)$$

$$P_{leakage} = V_{dd} * I_{leakage} = V_{dd}^2 / R_{sbd} \quad (5)$$

To understand leakage power $P_{leakage}$, it must be noted that there is no such thing as a perfect IC. Due to breakdown, there is current leaking from the gate to other regions, such as the source region. This leakage current increases as circuit degradation gets worse.

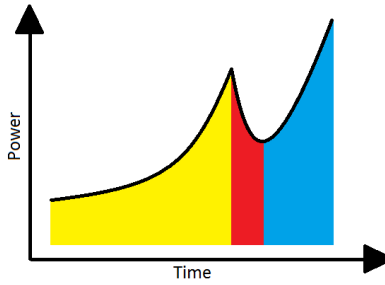

Figure 13. Power Consumption behavior for Gate-to-Source Breakdown

The data collected from the simulations of ring oscillators with various stages show a curve that predicts power consumption over time, as shown in Fig 12 (actual data) and Fig 13 (pictorial representation). The yellow region shows a non-linear increase in total power. This region is the SBD region, where the switching power is constant and the leakage power rises as R_{sbd} decreases. HBD begins in the red region, where the period of the IC rises dramatically until it reaches infinity. Since period is the reciprocal of frequency, the switching power goes to zero, and the power consumption drops significantly. R_{sbd} is still decreasing, which means the leakage power continues to increase. Even though the switching power no longer contributes to total power consumption, leakage power is still growing, hence the rising curve in the blue region.

B. Gate-to-Drain

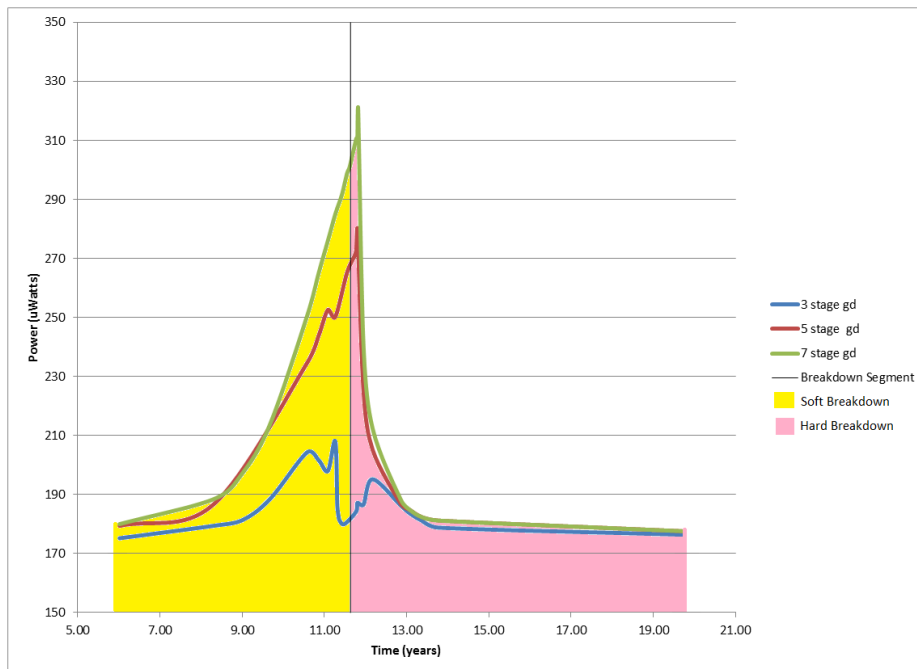

Figure 14. Power vs. Time for Gate-to-Source Breakdown

In contrast to the GS graph, the Gate-to-Drain (GD) breakdown shows interesting behavior in the HBD region. From the data gathered, a Power-Time pattern is created, as shown in Fig 14 (actual data) and Fig 15 (pictorial representation).



Figure 15. Power Consumption behavior for Gate-to-Drain Breakdown

The yellow region in Fig. 15 represents the SBD region. Similar to GS breakdown, as the value of R_{sbd} decreases, the leakage current increases, thus overall power consumption rises. When HBD begins, total power consumption decreases until it reaches a steady state, as shown in the pink region.

C. Different Power Behavior for Severe HBD

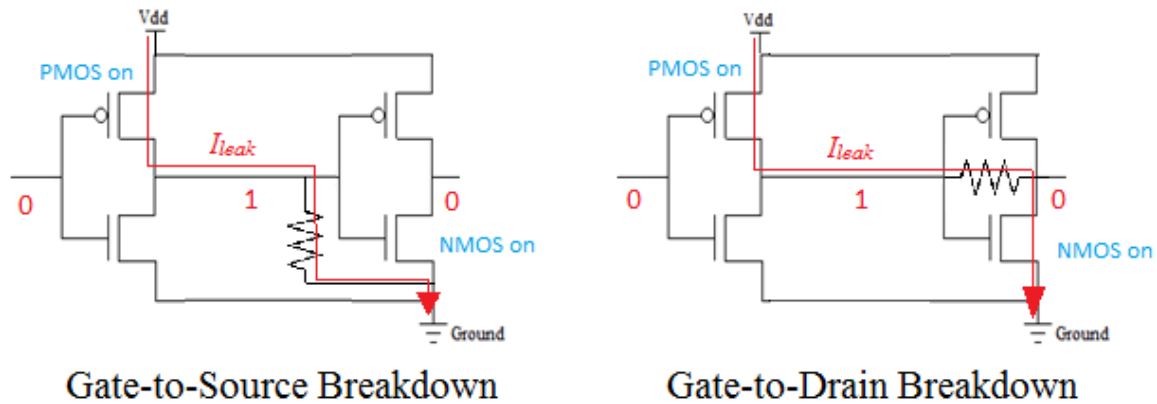

Figure 16. Leakage current paths for GS and GD breakdown

In Figs. 12 and 14, the significant increase in power in GS breakdown that is not present in GD breakdown can be attributed to the different pathways of the leakage current. In GS breakdown, the leakage current flows across the leakage resistor and PMOS transistor that acts as a resistor in its on-stage. Although there is increased resistance due to the PMOS transistor, the leakage current is still able to flow from V_{dd} to ground. Hence, total power consumption for GS breakdown increases again, as shown by the blue region in Fig. 13.

In GD breakdown, the leakage current I_{leak} flows across the PMOS transistor, leakage resistor, and NMOS transistor. It is more difficult for the current to flow compared to GS breakdown. The leakage power for GD breakdown becomes,

$$P_{leakage} = V_{dd}^2 / (R_{sbd} + R_{PMOS} + R_{NMOS}) \quad (6)$$

The high resistance reduces the leakage current significantly so that its effect on total power consumption can be neglected.

After HBD, further decrease in leakage resistance no longer affects the circuit, and total power consumption is simply given by

$$P_{total} = f * C * V_{dd}^2 + V_{dd}^2 / (R_{PMOS} + R_{NMOS}) \quad (7)$$

Because total power is independent of leakage resistance, all of the ring oscillator curves converge to some constant power value, regardless of the number of stages in the IC.

D. Initial Leakage Current Effect on Power

For both GS and GD breakdown, it is observed that as the number of inverters in the ring oscillator increases, the area under the Power curve gets larger. To explain this behavior, the effects of initial leakage current must be considered.

The initial leakage current I_0 is an inherent characteristic, which is caused by imperfections in the IC. Also, as IC design gets better, the Gate Oxide region gets smaller, which contributes to the increase in current tunneling. It is not the same as leakage current caused by breakdown. Total leakage current is the sum of breakdown current and initial leakage current. Each inverter in the ring oscillator has its own initial leakage current; therefore, total leakage current is,

$$I_{leakage} = I_{bd} + n * I_0 \quad (8)$$

In Eqn. 8, I_{bd} is the breakdown current and n is the number of inverters in the ring oscillator. Incorporating this initial leakage current effect, Leakage Power becomes,

$$P_{leakage} = V_{dd} * I_{leakage} = V_{dd} * (I_{bd} + n * I_0)$$

$$P_{leakage} = (V_{dd}^2/R_{sbd}) + (n*V_{dd}*I_0) \quad (9)$$

Total power consumption is dependent on the number of inverters in the ring oscillator, which explains why the seven stage ring oscillator consumed the most power and had the largest area under its power curve among the ring oscillators that were tested.

VI. EXPERIMENTAL RESULTS

This portion investigates the validity of the simulations conducted on the computer program. Using the Cascade B11000 Probe Station and Agilent B1500A Device Parameter Analyzer, the test chip was probed at its voltage and ground nodes while applying 1.8V at 20°C provided by the Source Monitor Unit (SMU), and produce the I-V graph for the fresh test chip. The chip is then stressed with the Semi-Conducting Pulse Generator (SPGU) at 3.5 V at 140°C for approximately one hour at 90% duty cycle with 1ms period to accelerate the process of SBD. After stress, the chip was probed to original quantities and its I-V graph was made. The same process was performed except at 100°C and a graph was created. Fig. 17 represents the defect current of the chip due to the breakdown.

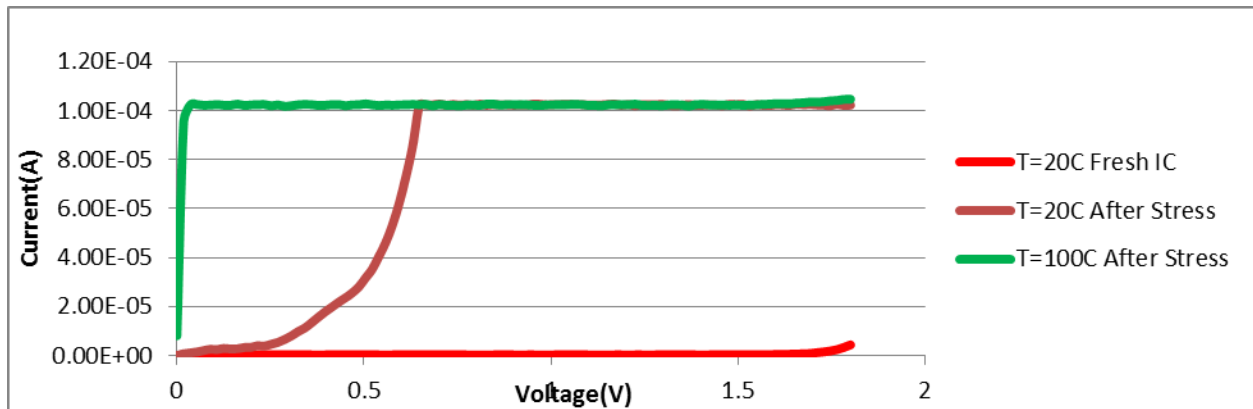

Figure 17. I-V characteristic of fresh IC and IC after stress



Figure 18. Power supply section of chip under test

VII. STUDENT SURVEYS

Table 2 summarizes the results of post-program student survey designed to measure perception of over-all usefulness of the research internship program. Results show that the research internship program was successful in its achieving its goals of helping students prepare for transfer, solidify their choice of major, increase their confidence in applying for other internships, and enhance their interest in pursuing graduate degrees. Overall, students were satisfied with the program, and would recommend it to a friend.

The internship program was successful in achieving its goals of developing students' skills needed for academic success. Table 3 shows a summary of student perception of how much they have learned from participating in the internship program, as determined from a post-program survey. Note that for each of the categories, the average response is between "Quite a bit" and "A lot."

Table 2. Summary of student responses to the post-program survey measuring the perceived benefit of participating in the research internship program.

Question: Tell us how much you agree with each of the following statements.	
Response Scale: 1 – Strongly Disagree; 2 – Disagree; 3 – Neutral; 4 – Agree; 5 – Strongly Agree.	Average Rating
The internship program was useful.	4.9
I believe that I have the academic background and skills needed for the project.	4.1

The program has helped me prepare for transfer.	4.5
The program has helped me solidify my choice of major.	4.3
As a result of the program, I am more likely to consider graduate school.	4.6
As a result of the program, I am more likely to apply for other internships.	4.8
I am satisfied with the NASA CIPAIR Internship Program.	4.8
I would recommend this internship program to a friend.	4.8

Table 3. Summary of student satisfaction with the summer research internship program.

Question: How much did you learn about each of the following?	Average Rating
Response Scale: 1 – Nothing; 2 – A little; 3 – Some; 4 – Quite a bit; 5 – A lot.	
Performing research	4.8
Designing/performing an experiment	4.9
Creating a work plan	4.8
Working as a part of a team	4.8
Writing a technical report	4.8
Creating a poster presentation	4.7
Making an oral presentation	4.6
Performing research	4.8

VII. CONCLUSION

Adding resistors to the IC produces reliable approximations to the effects of SBD. The equation relating leakage resistance to time allows our circuit model to behave like a typical integrated circuit.

The results of the gate to source individual delay and the total period of the three, five and seven stage ring oscillators show no perceptible difference up to the hard breakdown point.

The gate-to-drain data shows a much larger change of about 8%, which is shown as an increase in performance rather than a decrease. We conclude that delayed multisampling is not possible due to the small differences in delay and period.

This research confirms that power consumption increases due to the growing leakage current from SBD. It has been observed that there is a point, called Hard Breakdown Point, where power consumption actually starts to decrease. Experimental results support our observations by simulations.

Our research goes beyond the scope of prior research by analyzing the circuit behavior as the SBD progresses to HBD. The HBD behavior is different for GS and GD breakdowns. In the BD region the delay continues to increase until the circuit fails. The power shows an irregular behavior depending on the location of the breakdown.

VIII. BIBLIOGRAPHY

- [1] B. Van Zeghbroeck. "The MOSFET – Introduction." Internet: <http://ecee.colorado.edu/~bart/book/mosintro.htm>, 1997 [July 11, 2012]
- [2] N. Azizi. "Gate Oxide Breakdown". December 2, 2003.
- [3] T. Chen, Y. Kim, K. Kim, Y. Kameda, M. Mizuno, S. Mitra. "Experimental study of gate oxide early-life failures," IEEE International, Reliability Physics Symposium, 2009.
- [4] H. Nan, L. Li, K. Choi. "TDDB-Based Performance Variation of Combinational logic in Deeply Scaled CMOS Technology," 13th International Symposium, Quality Electronic design (ISQED), 2012.
- [5] B. Afzal, B. Ebrahimi, A. Afzali-Husha, H. Mahmoodi. "Modeling read SNM considering both soft oxide breakdown and negative bias temperature instability"
- [6] M. Choudhury, V. Chandra, K. Mohanram, R. Aitken, "Analytical model for TDDB-based performance degradation in combinational logic", Design, Automation & Test in Europe Conference & Exhibition (DATE), pp. 423-428, 2010.

Development and Use of a Construction Engineering Gaming Simulation in the Global Environment

Thomas M. Korman, Ph.D, P.E., M.ASCE, Hal A. Johnston, C.P.E. /Lloyd Crask, P.E.
California Polytechnic State University, San Luis Obispo
California State University, Fresno

Abstract

Simulations and learning games use technology to create real-world experiences to provide the opportunity to engage, have fun, and truly learn. Many have been designed to meet specific learning goals, i.e. sharing case studies to demonstrating very complex situations. Gaming is not new to higher education but in the past was done in a very narrow vein and because of the complexity and development time required to produce them. Most have not been robust enough to engage students. Managing Construction involves being able to make decision to balance time, cost, quality, resources, and identifying and solving a variety of issues. As the millennium generation enters the higher education system many have spent many hours playing computer games as they have in the classroom during their lifetime; therefore, it is a natural transition that our learning environments begin to use techniques from the gaming world. The skills required of today's construction management personnel are a combination of management skills and technical knowledge. This paper describes the development of gaming system designed and developed at California Polytechnic State University, San Luis Obispo to educate civil and construction engineering students.

Introduction and Background

Experiential learning is learning through reflection on doing, which is often contrasted with didactic learning. Experiential learning is related to, but not synonymous with, experiential education, action learning, adventure learning, free choice learning, cooperative learning, and service learning. While there are relationships and connections between all these theories of education, importantly they are also separate terms with separate meanings.

Experiential learning focuses on the learning process for the individual (unlike experiential education, which focuses on the transactive process between teacher and learner). An example of experiential learning is going to the zoo and learning through observation and interaction with the zoo environment, as opposed to reading about animals from a book. Thus, one makes discoveries and experiments with knowledge firsthand, instead of hearing or reading about others' experiences.

Experiential learning requires no teacher and relates solely to the meaning making process of the individual's direct experience. However, though the gaining of knowledge is an inherent process that occurs naturally, for a genuine learning experience to occur, there must exist certain elements. According to David A. Kolb, an American educational theorist, knowledge is

continuously gained through both personal and environmental experiences. He states that in order to gain genuine knowledge from an experience, certain abilities are required:

- the learner must be willing to be actively involved in the experience;
- the learner must be able to reflect on the experience;
- the learner must possess and use analytical skills to conceptualize the experience; and
- the learner must possess decision making and problem solving skills in order to use the new ideas gained from the experience.

COInstruction Industry Simulation (COINS) – An educational gaming simulation for Construction Engineering

Construction Industry Simulation (COINS) is a computer simulation built to simulate the business environment for a construction company. The players, participants, play the role of contractors, competing in a market with variable demand for construction work. The simulation immerses students into the day-to-day operations of a construction company, requiring them to management specific aspects of the company with the goal of procuring and managing construction work in terms of its planning, scheduling, and resource allocation. Students have a choice between commercial construction company, a heavy construction company, or a company that does both. Players are required to set up a complete business strategy including the following tasks:

- examine available information
- determine the best portfolio of jobs to bid on
- create strategies to improve bonding limits
- set strategies to create negotiated work
- develop bid prices for desired jobs
- monitor their financial position as work progresses
- monitor and create strategies to improve company’s appraisal metrics
- choose and modify their construction methods to meet due dates and reduce costs
- interpret their competitors' strategies
- respond to changing conditions and situations proposed to the company and driven by the decisions and actions of the company

Commercial Building Projects	Heavy Civil Projects
<ul style="list-style-type: none"> • Apartment buildings • school buildings • office buildings • hospital buildings • industrial plants 	<ul style="list-style-type: none"> • highways • bridges • site development • mass excavation • underground utilities

Each period the simulation generates a list of jobs available for bidding and creates an Estimated Time and Cost Report for each job. Using the this information, each company must decide which jobs to bid on, the bid price, and which of the five methods to use for each of the activities. All jobs will have up to nine activities (Both Heavy and Commercial). These activities are:

Commercial Building Projects	Heavy Civil Projects
<ul style="list-style-type: none"> • Excavation • Foundation • Basement • Framing • Closure Roof • Siding • Finishing • Mechanical and Electrical 	<ul style="list-style-type: none"> • Clear and Grub • Rough Grading • Excavation • Underground piping • Concrete (Form and Place) • Backfill and Compaction • Aggregate Base • Paving • Finish Grading

Every activity has five (5) different construction methods that vary in time and cost. The fifth method is generally use of a subcontractor. All five methods of activity #9 (Mechanical and Electrical) are generally subcontracted. The Estimated Time and Cost Report gives labor and material costs and the amount of time required for every activity using each of the five methods. Heavy construction bids are generally unit price bids while commercial bids are lump sum.

Phase 1 - Project Planning and Design

Students begin the simulation in Phase 1 by being presented with a list of potential projects to review. Considering market conditions, student teams proceed by selecting a project to plan and then designing a project control system for the project. This is accomplished by selecting methods for each project activity and balancing the schedule and cost considerations. In Phase 1, students compete against their peers as well as the simulation’s virtual companies for award of the project. Award of projects is based on the team’s accuracy and proximity to the simulation’s internal estimate. Teams that are not initially awarded a project for their efforts must continue with the simulation, refining their plans, until their plans are awarded a project. Thus, the COINS simulation enables students to learn from their mistakes.

Phase 2 – Construction Engineering

When a student team is awarded a project, they enter Phase 2. In Phase 2 student teams must manage their project by monitoring and controlling the project activities, analyzing the schedule and costs in reference to the methods to the activities they selected for each activity. Throughout the duration of their project, students are presented with real-life scenarios which they must respond to, thus measuring, testing, and validating the design of the project control system. Therefore, students are able to utilize their knowledge and hone their skills at controlling the process through modifying their project control system. The simulation provides feedback to the students which they then can use to continuously improve their model throughout the duration of the simulation.

Phase 3 – Project Closeout

Phase 3 begins after students have completed each activity for their virtual project. They have the opportunity to evaluate their performance using several predefined metrics, including Schedule Variance, Cost Variance, Cost Performance Index, and Schedule Performance Index.

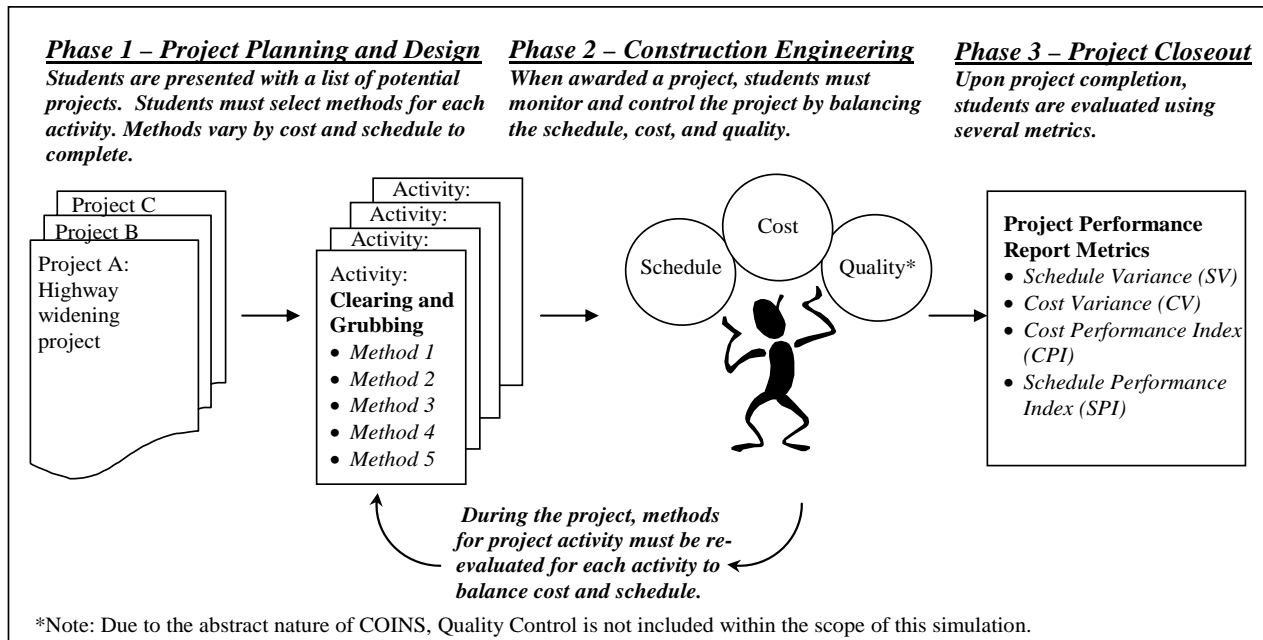

Figure 1 – Project Phases

As mention above, one of the first activities for the students is to determine what positions will make up their main office overhead. This is reevaluated each period, and hire/fire activity is performed by the team. A report is given to the company telling them how they are handling their personnel and it's requirements. Work scheduling is very important in the selection of the methods so projects can be completed by the contractual deadlines, and the costs reduced as much as possible. Each bid price submitted should cover all the firm's direct and indirect job expenses, its main office overhead costs, and the desired profit. At the end of each period the simulation will determine which company is awarded each available project. The lowest bid will not necessarily win since the computer takes into account several other factors:

- Is the firm's cash-on-hand adequate to provide enough liquidity with regard to the bid price?
- Is the bid price below a minimum amount, computed by the program? If so, then the bid will be disregarded as irresponsible and be rejected.
- Is the bid price higher than the unknown contractors, the presence of this simulated company assures a competitive, uncertain environment with realistic bid prices.
- Is the firm within it bond limits?

Companies must monitor their financial situations as the game progresses, forecasting and completing progress payments, and potential needs for loans. In any period, participants have the option to ask for information on weather forecasts, material prices, labor and material availability, and market projections. These requests for consulting services have a cost and are charged against the firm's financial account. Using the information obtained from these reports, companies can determine the best strategy to proceed for each individual job.

At the end of each period, teams receive a progress report for the previous two month period, giving a statement of the firm's work progress on each of its jobs during that time. It shows the amount of work completed as well as the expenses incurred for each activity in every one of the

company's projects. The amount of work completed during a period depends not only on the methods selected for the various activities, but also on uncertainty factors during that time such as the weather conditions, labor availability, and the fluctuating cost of materials.

An end-of-period financial report is also provided to the participants showing the expenses incurred during that period. It lists amounts spent on direct construction services, bidding costs, delay fines, taxes incurred, and interest on borrowed money. It also shows payments to the contractor by the owner according to the payment requests and gives total cash-on-hand at the end of the period. Each firm may at any time apply for a loan to improve its financial situation. Loans granted are amortized over a one year time period. Changes in company ratios are also logged along with changes to the company's appraisal metrics.

- Financial Liquidity
- Financial Success
- Responsibility
- Pace
- Ethics
- Name Recognition

At the end of a period, the firms examine their Progress Reports and decide on the effectiveness of the methods chosen for the various work activities. If they wish, they may change them and specify different methods for the following periods. The choice of methods allows companies to utilize slower but cheaper methods if they fear budget overruns, or faster but more expensive methods if meeting contractual deadlines is the main concern. In addition, overtime may be used to speed up certain activities, greatly increasing the labor costs. Firm must be concerned with the amount of liquidated damages on each project as they vary from project to project.

At the conclusion of the simulation, the program provides each participating company with a final report, forecasting the expected results of any on-going projects or their position at that point in time. It also shows the final total worth of the firm. Teams should consider maximization of profit as one of their main objective, and one of the primary criteria used to evaluate each firm's performance. As the simulation progresses, evaluations of company ratio, and appraisal metrics can be used to determine successful completion of the simulation.

Global Use of the Simulation

At Cal Poly, COINS has been used in several courses including:

- Professional Practice
- Construction Estimating
- Construction Accounting
- Management of the Construction Firm
- Business Practices

During the 2005/2006 academic year, the simulation was used for regional competition between multiple universities in the Associated Schools of Construction Regional 6 and 7 Student Competition.

Most recently, in November 2009, universities from the Czech Technical University (CTU) - Prague, Czech Republic, Auburn University – Alabama, California State University, Fresno - California, Illinois State University - Illinois, Boise State University - Idaho, Western Carolina University - North Carolina, and Washington State University – Washington, participated in an international competition. Competition Results were evaluated in three categories: Highest Retained Earning - received the highest profit, Highest Appraisal Metrics - the best valuation metrics and third, Most Awarded Projects - the company with the most awarded projects.

Most recently, between September 2012 and December 2012, the authors sponsored an international game where universities from the Czech Technical University (CTU) - Prague, Czech Republic, California State University, Fresno, California Polytechnic State University, San Luis Obispo, and Northwestern University, Illinois State University completed against each other. The competition concluded with an assessment of student learning described below.

Assessment of Student Learning

The simulation has a built-in grading module that can be used to obtain statistic on the various companies for comparison or to use in the classroom for grading the simulation. Each faculty can have their own method of grading. The following on faculty used a criteria for assessing participation and student learning:

- Number of jobs bid
- Minus the jobs rejected (i.e., not enough bonding capacity, substantially low cost estimate, etc.)
- Number of times the number jobs you are the lowest cost
- Number of times the company retained earnings
- Company's appraisal metrics

Using the seven principles of good practice as an evaluation metric, the COINS system performs well. It encourages contact between students and faculty by encouraging frequent student-faculty contact in and out of classes, which is an important factor in student motivation and involvement. Faculty concern helps students get through rough times and keep on working. Knowing a few faculty members well enhances students' intellectual commitment and encourages them to think about their own values and future plans. It develops reciprocity and cooperation among students. When using the COINS systems, learning is enhanced when it is more like a team effort than a solo race. Good learning, like good work, is collaborative and social, not competitive and isolated. Working with others often increases involvement in learning. Sharing one's own ideas and responding to others' reactions sharpens thinking and deepens understanding. COINS encourages active learning. Learning is not a spectator sport. Students do not learn much just by sitting in classes listening to teachers, memorizing pre-packaged assignments, and spitting out answers. They must talk about what they are learning, write about it, relate it to past experiences and apply it to their daily lives. They must make what they learn part of themselves. COINS gives prompt feedback. Knowing what you know and don't know focuses learning. Students need appropriate feedback on performance to benefit from courses. When getting started, students need help in assessing existing knowledge and competence. In classes, students need frequent opportunities to perform and receive suggestions for improvement. At various points during college, and at the end, students need chances to

reflect on what they have learned, what they still need to know, and how to assess themselves. The use of COINS emphasizes time on task. The time plus energy equals learning. There is no substitute for time on task. Learning to use one's time well is critical for students and professionals alike. Students need help in learning effective time management. Allocating realistic amounts of time means effective learning for students and effective teaching for faculty. How an institution defines time expectations for students, faculty, administrators, and other professional staff can establish the basis of high performance for all. Use of COINS communicates high expectations. Expect more and you will get more. High expectations are important for everyone -- for the poorly prepared, for those unwilling to exert themselves, and for the bright and well-motivated. Expecting students to perform well becomes a self-fulfilling prophecy when teachers and institutions hold high expectations for themselves and make extra efforts. COINS respects diverse talents and ways of learning. There are many roads to learning. People bring different talents and styles of learning to college. Brilliant students in the seminar room may be all thumbs in the lab or art studio. Students rich in hands-on experience may not do so well with theory. Students need the opportunity to show their talents and learn in ways that work for them. Then they can be pushed to learn in new ways that do not come so easily.

Discussion and Recommendations for Future Implementations

Some early recommendations during the first stage the simulations development included: creating learning objectives, creating an outline or direction, and to create modules. Even the simple simulations generally cannot be completed during the first development stage. Having a framework of different modules and what each might accomplish is critical to success and the development process. Most times having a group to develop this direction and the different modules that might be needed is a key to creating complex and broad simulations.

To assist in the development of COINS, the developers have developed an Industry Advisory Board (IAB) from the construction industry as well as a working group of educators to continue the development and ideas for changes. Because of the idea of module development COINS can turn on and off some of its modules, making it a better fit in different classes. For example, estimating can be turned to an automatic mode which in a construction accounting class helps the student focus on accounting and not on the estimating itself which can be very time consuming and complex. Periods can move much quicker giving the students more accounting to analyze and in a shorter time in which they can see the changes that occur within a company without being bogged down in the estimating/procurement of work. Billing can be turned on to auto mode and additional projects can be added to each team to create additional project or backlog. The game play between commercial and heavy/civil construction is also modularized so a faculty can play only commercial, heavy/civil or both can be played in one game. Future additions are also planned as modules, i.e. personnel additions, case studies, and wide use of equipment management.

Bibliography

1. Bonds, C.; Cox, C. III; and Gantt-Bonds, L. "Curriculum Wholeness through Synergistic Teaching." *The Clearing House* 66/4 (1993): 252-254.

2. Bonwell, C.C. and Eison, J.A. Active Learning: Creating Excitement in the Classroom. ASHE-ERIC Higher Education Report No. 1, George Washington University, 1991.
3. Felder, R.M. and Brent, R. Cooperative Learning in Technical Courses: Procedures, Pitfalls, and Payoffs. ERIC Document Reproduction Service Report ED 377038, 1994.
4. Johnston, Hal, Borland, Jim, and Craig, K., " Building Industry Game (B.I.G.) A Computer Simulation for Construction Management," ASC Proceedings of the 39th Annual Conference, pp 79-90. [Online]. Available: <http://ascpro0.ascweb.org/archives/cd/2003/2003pro/2003/Johnston03.htm>
5. Korman, Thomas M., and Johnston, Hal A., "Development of Use of a Virtual Construction Company Simulation System for Education", FECS'12 The 2012 International Conference on Frontiers in Education: Computer Science and Computer Engineering, WORLDCOMP'12 The 2012 World Congress in Computer Science, Computer Engineering, and Applied Computing, Las Vegas, NV. July 2012.
6. Korman, Thomas M., "Design and Implementation of Experiential Learning Exercises for Commercial Building Construction Education" Proceedings of the 2012 ASEE PSW Section Conference, Cal Poly - San Luis Obispo, CA, April 2012.
7. Korman, Thomas, and Johnston, Hal, "Enhancing Construction Engineering and Management Education using a COINSTRUCTION INDUSTRY SIMULATION (COINS)", 2011 ASCE International Workshop on Computing in Civil Engineering: June 19-22, 2011, Miami, FL, USA.
8. Korman, Thomas M. and Johnston, Hal "Enhancing Construction Management Education through the use of a Virtual Construction Company Simulation System, " The 2nd International Symposium on Engineering Education and Educational Technologies: EEET 2010 in the context of The 3rd International Multi-Conference on Engineering and Technological Innovation: IMETI 2010, Orlando, FL, July 2010
9. Lacey Duckworth, Dr. Tulio Sulbaran, Dr. Andrew Strelzoff, Professor Hal Johnston, "Application of a Communication Protocol Methodology to Embed a Collaborative Virtual Reality Environment in Building Industry Game" The 2011 International Conference on Software Engineering Research and Practice

Integrating Earthquake Engineering into Community College Student Educational Experience through a Summer Internship

Cheng Chen¹, John DeAndreis², Peter Moala², Agustin Robles², Jose Valdovinos², Qiming Zeng¹, Amelito G. Enriquez², Wenshen Pong¹, Hamid Shanasser¹, Hao Jiang¹, Hamid Mahmoodi¹

¹School of Engineering, San Francisco State University, San Francisco, CA

²Cañada College, Redwood City, CA

Abstract

Young professional civil engineers are critical for preparing the San Francisco Bay Area for future earthquake events. Many of these future engineers will come from community colleges, which serve as a gateway to higher education for large numbers of students, especially minority and low-income students. Preparing community college students for their future engineering career and engaging them in professional development is one of the major objectives of the NASA CIPAIR (Curriculum Improvements and Partnership Award for the Integration of Research) program. In the San Francisco Bay Area, a collaborative NASA CIPAIR program between Cañada College, a federally designated Hispanic-serving community college, and San Francisco State University, a large urban university, has developed a summer internship program that provides freshmen and sophomore community college students an opportunity to participate in a ten-week study of earthquake engineering. For the summer 2012 internship program, students designed a five-story steel special moment-resisting frame, and evaluated its performance under four selected ground motions. The students optimized the structural design through iterative computer-based dynamic time history analysis. Structural analysis program SAP2000 was incorporated into the design process for students to examine story drift, and the capacity of the structural members. The ten-week program was found to be successful in engaging community college students in the civil engineering career thereby helping train future American workforce for seismic hazard mitigation.

Introduction

Earthquake engineering is concerned with design and analysis of structures to withstand earthquakes at specific locations. Steel structure design is one of the main approaches to this mission. Starting in the late 1800's, steel became readily available for applications in large-scale engineering structures. This triggered a tide of tall buildings, including the Home Insurance Building in Chicago and the Manhattan Building in New York¹. Steel frame buildings began to rise all across the nation without any major changes in their connections or design for nearly a century after the 1880's. But after the structural failures during the 1994 Northridge Earthquake, there was a fundamental rethinking in the design of seismic resistant steel moment connections. This led to the SAC Steel Project research funded by FEMA². The San Francisco Bay Region experienced large and destructive earthquakes in 1838, 1868, 1906, and 1989. In a recent study, scientists and engineers released a new earthquake forecast for the earthquake forecast made for the greater San Francisco Bay Area as shown in Figure 1. The research predicts that the

probability of earthquakes of magnitude 6.7 or greater in the next 30 years is 63%³. Future earthquake disaster prevention and preparation require that young professional civil engineers be trained and recruited into the next generation workforce as part of the efforts to mitigate the seismic hazard and improve public safety.

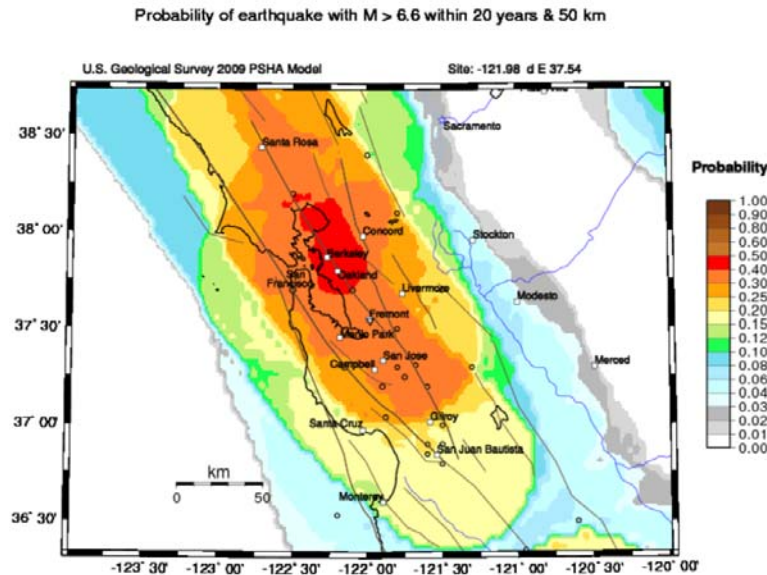

Figure 1. Probability of Earthquakes in the San Francisco Bay Region

Community colleges such as Cañada College serve as the gateway to higher education for large numbers of students especially in California. However, for science and engineering fields, lower success and retention rates are observed at both community college and university levels resulting in underrepresentation of minority groups in these fields. The NASA CiPair program between SFSU and Cañada College addresses some of these barriers to the successful transfer of community college engineering students to a four-year institution including inadequate preparation for college-level courses, especially in mathematics, low success rates in foundational math courses, lack of practical context in the traditional engineering curriculum, and inadequate relevant internship opportunities for lower-division engineering students.

Cañada College is a member of the California Community College System, and is one of three colleges in the San Mateo County Community College District. It is one of only two federally-designated Hispanic Serving Institutions in the San Francisco Bay Area. During the 2011-2012 academic year, the College enrolled 10,965 unique students. The student body is genuinely multi-cultural with Hispanic students as the largest single group at 35.5%; white students comprise 32.6%, Asians 8.1%, Filipinos 3.4%, African-Americans 3.9%, Pacific Islanders 1.7%, American Indian/Alaska Natives 0.3%, multi-racial 9.5%, unknown 4.9%. San Francisco State University is a large, regional, comprehensive university, part of the California State University System. In fall 2009, 30,469 students enrolled at SFSU: 25,001 undergraduates and 5,468 graduate students. Students pursue 115 undergraduate majors, 97 master's degree programs, 27 credential programs, and 37 undergraduate and graduate certificate programs. According to the fall 2009 Undergraduate Student Profile, although white students form the largest racial/ethnic group of undergraduates at 32.8%, 24.9% are Asian, 19.9% are Hispanic, 9.4% are Filipino,

6.0% are African American, 0.9% are Pacific Islander, 0.5% are American Indian or Alaska Native, and 5.6% are “other.” Women comprise 59.7% of the student body.

The objectives of the NASA CiPair project are: (1) to improve student engagement and success in foundational math courses and core engineering courses; (2) to provide ten participants each summer with research experiences in NASA Ames, which they would not otherwise have in their usual academic environment; (3) to provide current community college students a year-long engineering design experience early in their academic career by participating in capstone design courses for graduating seniors; (4) to strengthen existing faculty relationship with NASA Ames, and establish new collaborative relationships among two-year and four-year engineering faculty, and NASA Ames Research Center; (5) to increase the number of academically prepared community college students transferring to four-year institutions as engineering majors; (6) to improve academic success of engineering students from underrepresented groups by providing academic support and mentoring; and (7) to increase the number of minority students pursuing advanced degrees in STEM fields.

Summer Intern Project Description

For the second year of the project in summer 2012, a total of twelve students were selected through an application process and participated in the CiPair Program. Four of these twelve students chose to work on a civil engineering project, which composed of designing a 5-story office building in an earthquake prone area, where steel moment-resisting frames are used as a major lateral resistant system. Figure 3 shows a schematic of the project office building. The AISC Steel Manual⁴ and ASCE 7-05 Minimum Design Loads for Buildings for structural design⁵ were the main references for their design.

Table 1. Design load for the five-story office building

Building Specifications	Dead load (psf)	Live load (psf)	Height (ft)
Roof	95	20	11
5	90	50	11
4	90	50	11
3	90	50	11
2	92	50	13

The five-story special steel moment frame structure is assumed to be located at 3939 Bidwell Drive, Fremont, CA 94538 and will be an office building designed with large open spaces in the center, and large windows to allow for the most natural light to enter these areas. Table 1 shows the live loads of 50 psf (pounds per square foot) at each floor and 20 psf for the roof. Dead loads (including the weight of the building) were assigned as 95 psf on the roof, 92 psf on the second floor and 90 psf on the third, fourth and fifth floors. The height of the first floor is 13 feet, and 11 feet for the second, third, fourth and fifth floors. Figure 2 shows the dimensions of the entire building. This building is designed according to AISC’s code and ASCE’s equilateral force procedures. Computer software SAP 2000⁶ is required for the students to analyze the structure under given loads.

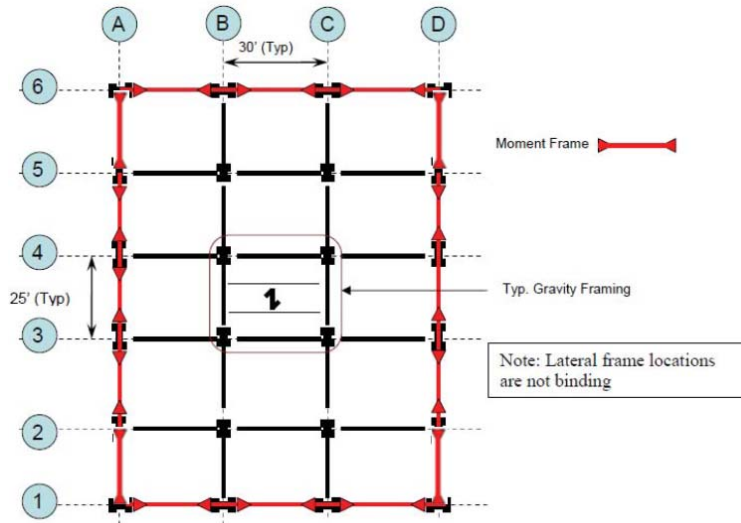

Figure 2- Top view of building

Structural Design Project Outcome

During the 10-week internship program, the four students were expected to acquire necessary knowledge on structural design and evaluation of a steel moment-resisting frame. To accommodate their different educational backgrounds, the CiPair Program set up a two-level instructional team that includes a faculty advisor and a graduate student. Fundamental concepts in steel design were explained to the intern students by the graduate student and then reinforced by relating the concepts to the equations in the design manual.

Table 2 presents the calculation of the horizontal distribution forces and the accidental torsions conducted by the students following the equivalent lateral force procedure. Figures 3 and 4 show the member selection for the first and final design of the moment resisting frame in the E-W and N-S direction, respectively. Tables 3-4 present the check of the selected beam for bending.

Table 2. Horizontal distribution forces and accidental torsions for structural design

Horizontal Distribution Forces and Accidental Torsions							
Floor	h_i	w_i	$w_i h_i^3$	$\frac{w_i h_i^3}{\sum (w_i h_i^3)}$	F_x	$.5F_x$	V_x
Units	ft	K			kips	kips	kips
Roof	57	1068.75	93136.06	0.35	327.91	163.95	0
5	46	1012.50	69621.35	0.261	245.12	122.56	327.91
4	35	1012.50	51474.28	0.19	181.23	90.61	573.02
3	24	1012.50	33925.67	0.13	119.44	59.72	754.25
2	13	1035.00	17613.58	0.07	62.01	31.01	873.70
1	0	0.00	0.0000	0.0000	0.0000	0.0000	935.71
	sum	5141.25	265770.93	1.0000	935.71	467.85	935.71

The student interns are guided to develop a preliminary design and then a final design to improve the efficiency of the building. Figure

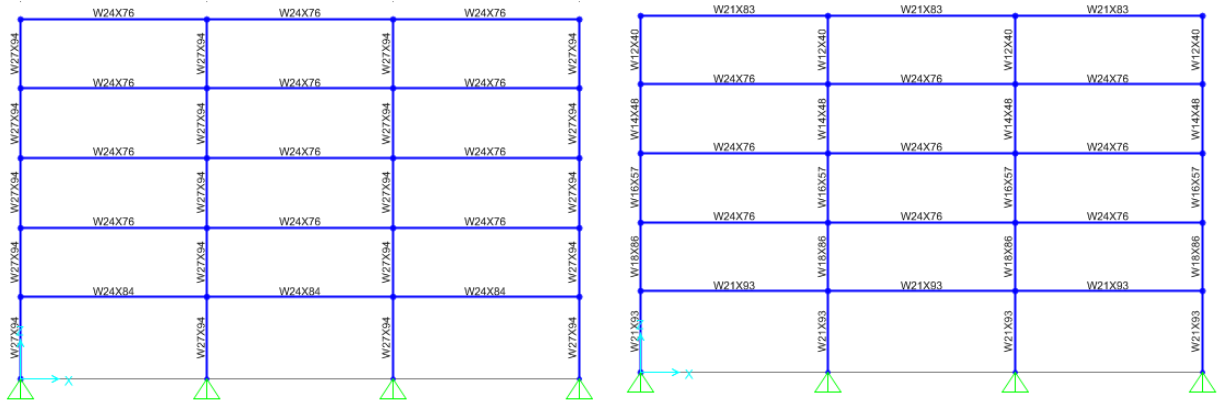

Figure 3. Building design in E-W direction: a) first design; b) final design

Table 3. Details of E-W Beams for final design

E-W beams	Members	W _u (kip)	M _u (<i>kip · in</i>)	Calculated Z _x (<i>in³</i>)	Z _x table (<i>in³</i>)	Check
Roof	W21X83	9.48	710.93	189.58	196	OK
5	W24X76	9.95	746.29	199.01	200	OK
4	W24X76	9.95	746.29	199.01	200	OK
3	W24X76	9.95	746.29	199.01	200	OK
2	W21X93	10.14	760.27	202.74	221	OK

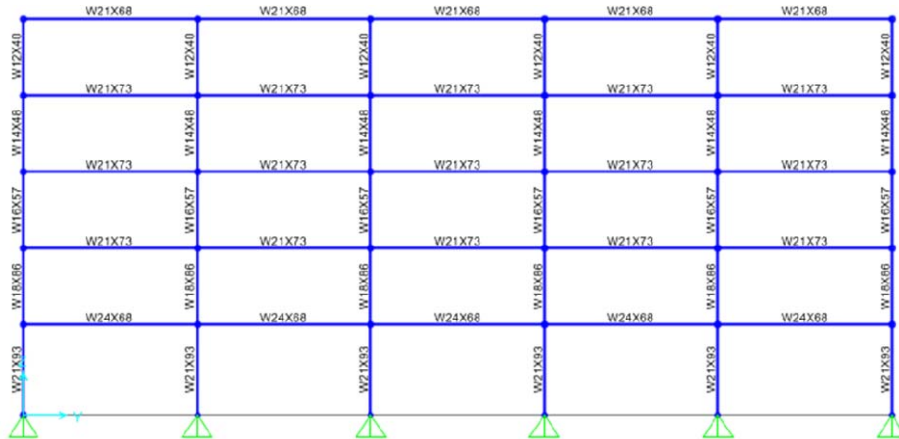

Figure 4. Building design in N-S direction: a) first design

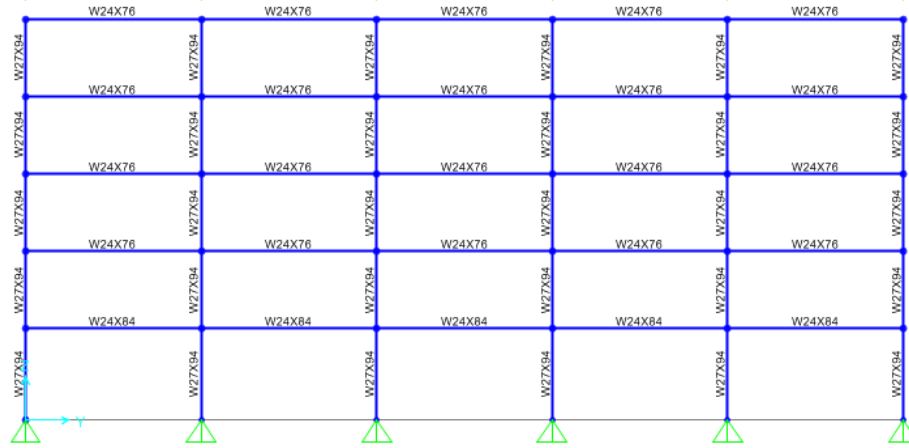

Figure 4. Building design in N-S direction: b) final design

Table 4. Details of N-S beams for final design

N-S beam	Members	Wu (kip)	Mu (kip · in)	Calculated Z _x (in ³)	Z _x (in ³)	Check
Roof	W21X68	11.37	592.44	157.98	160	OK
5	W21X73	11.94	621.91	165.84	172	OK
4	W21X73	11.94	621.91	165.84	172	OK
3	W21X73	11.94	621.91	165.84	172	OK
2	W24X68	12.16	633.55	168.95	177	OK

The member columns are checked by tests for effective slenderness and elastic buckling behavior. K, the effective length factor, is used for calculating the column slenderness, KL/r, where L is the laterally unbraced length of the member and r is the governing radius of gyration. The flexural buckling, F_e, stress test and elastic buckling, F_{cr}, test are to confirm if the building can retain its shape after being hit by an earthquake. The nominal strength, P_n, checks for local stability for proper thickness of the column web and strong axis bending strength⁷. These calculations and tests can be seen in Table 5.

Table 5. Strength checks of the columns

Columns	$\frac{KL}{r}$		Fe = $\frac{(\pi^2 \cdot E)}{(\frac{KL}{r})^2}$	F _{cr}	$P_n = F_{cr} \cdot A_g$		
Members	Slenderness ratio	Check	elastic critical buckling (ksi)	Flexural buckling Stress (ksi)	nominal strength (kips)	Local Stability	
roof	W12X40	68.0412	OK	61.8235	35.6418	417.0088	stable
5	W14X48	69.1099	OK	59.9262	35.2618	497.192	stable
4	W16X57	82.5	OK	42.0523	30.3977	510.6822	stable
3	W18X86	50.1901	OK	113.6217	41.5891	1052.2032	stable
2	W21X93	84.7826	OK	39.8184	29.5608	807.0101	stable

Structural analysis using computer software is emphasized in the program. In addition to the steel member design, the students were also trained on structural analysis using SAP2000, integrated software for structural analysis and design⁶. The students were instructed to use SAP 2000 for both equivalent lateral force design and the time history analysis. Ground motions recorded in four different earthquakes that occurred in California were selected by the students with magnitude between 6.0 and 7.0. Table 6 lists the details of the four ground motions for the SAP 2000 time history analysis by the students. The analysis results are presented in Figure 5, which shows that the final design satisfies the code requirement.

Table 6. Specifications on the four selected earthquakes

Earthquake	Magnitude	Duration (s)	Cost	Loss of Life
Loma Prieta, 1989	6.90	40	\$8 Billion	63 killed, 3,757 injured
Morgan Hill 1984	6.19	27	\$7 Million	27 injured
Northridge 1994	6.70	60	\$20 Billion	57 killed, 8,700+ injured
San Fernando 1971	6.61	70	\$505 Million	65 killed, 2,000+ injured

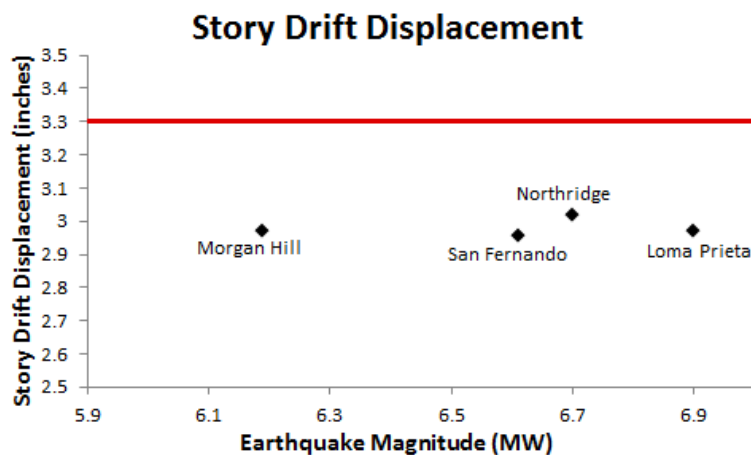

Figure 5. Story Drift Displacement from SAP2000 Analysis

To help propel NASA's goal of human settlement in outer space, the interns also analyzed special moment-resisting frames' behavior on the surface of the moon. They researched the landscape and studied the environment to gain a better understanding of the lunar conditions and determine if the designed structure would endure moon ground shaking. There are four different types of moonquakes, the technical term for seismic activity on the moon, which are deep moonquakes, meteorite impacts, thermal quakes, and shallow quakes. Shallow moonquakes is the most harmful type of moonquake as they are less intense (magnitude of 4 on the Richer scale) but last for a longer duration (up to 10 minutes) in comparison to earthquakes⁷. Shallow moonquakes due to the terrain of the moon being a large dry-rigid chunk of stone, seismic activity of the same magnitude/intensity on the moon would cause more damage than that on Earth where the water and soil dampen seismic vibrations. Low magnitude moonquakes will not cause serious damage to our structure but their extended duration causes issues such as low-cycle fatigue.

Project Assessment and Future Improvement

The internship experience enabled the interns to realize how trained civil engineers in the field will have to collaborate with other members on their team. Trained civil engineers will need to make weekly meetings with their supervisor to discuss their progress on their design and provide feedback on what they can improve. They will need to make a detailed, tentative plan that they must follow until their deadline when the building must be constructed. The research project could not have been completed by one engineer because it takes teamwork and collaboration on everyone's part to get the project done.

To obtain a quantitative assessment of the project and further improve the project in the future, an exit survey was conducted for all twelve student participants. Students were asked to rate their level of agreement with each question in a five point scale: 1 – Not at all useful; 2 – A little; 3 – Some; 4 – Quite a bit; 5 – A lot. The tables below present the students' response to some of the survey questions. The survey was conducted anonymously to help student express their opinions honestly.

Question: As a result of your participation in the program, how much did you learn about each of the following?

Activity	Average Rating
Performing research	4.69
Designing/performing an experiment	4.85
Creating a work plan	4.77
Working as a part of a team	4.85
Writing a technical report	4.85
Creating a poster presentation	4.62
Making an oral presentation	4.54

Question: Tell us how much you agree with each of the following statements.

Activity	Average Rating
The internship program was useful.	4.92
I believe that I have the academic background and skills needed for the project.	4.08
The program has helped me prepare for transfer.	4.38
The program has helped me solidify my choice of major.	4.38
The program has helped me solidify my choice of transfer university.	3.54
As a result of the program, I am more likely to consider graduate school.	4.46
As a result of the program, I am more likely to apply for other internships.	4.77
As a result of the program, I am more likely to consider SFSU as my transfer institutions, or recommend it to others.	3.77
I am satisfied with the NASA CIPAIR Internship Program.	4.85
I would recommend this internship program to a friend.	4.77

When asked the question "what do you like most about the NASA CIPAIR Internship Program?" Typical response from the civil engineering group students are: "I like the fact that we work in a group on a research project. We gain the experience and knowledge of working as a group." "The problem that we were given was a graduate level problem for student civil engineers. This project helps us advance our skills in civil engineering." "I liked how each day i had the chance of learning something new about my major and the principles that goes with Electrical Engineering. "The part I liked the most about this project was the safety inspections that we did at NASA Ames (full-time interns' assignment). I was able to learn a lot about the things NASA does to improve our lives." "I like the opportunity to conduct research and experience how theoretical concepts learned in class can be applied to real world situations. I like the environment created by adviser, mentor, and group mates. We could work and learn as we have some fun."

Summary and Conclusion

The NASA CiPair program has been very successful in helping students understand civil engineering topics and the engineering profession. Responses from the student participants are very positive. Among the students who solidified their choice of an engineering career and decided to major in one of the engineering fields, the program has provided context to their study of engineering – a strategy that has been proven to increase student motivation and persistence – especially as they struggle through the first two years of the engineering curriculum.

Acknowledgement

This project is sponsored by NASA Office of Education through the Curriculum Improvement Partnership Award for the Integration of Research (CIPAIR), Grant Number NNX10AU75G. The authors would like to acknowledge their support. Any opinions, findings conclusions and recommendations expressed in this paper are those of the author and do not necessarily reflect those of the sponsors.

Bibliography

1. History of Iron and Steel Bridges. History of Iron and Steel Bridges. TATA, 2012.
<http://www.tatasteelconstruction.com/en/reference/teaching_resources/bridges/history_of_steel_bridges/>.
2. Technical Background. SAC Steel Project: Project Description. SAC,
<<http://www.sacsteel.org/project/index.html>>.
3. United States Geological Survey, <http://earthquake.usgs.gov/regional/nca/ucerf/>
4. AISC Steel Construction Manual, 13th edition, 2005, ISBN 1-56424-055-X
5. ASCE/SEI 7-05 Minimum Design Loads for Buildings and Other Structures, 2006, ISBN 0-7844-0831-9
6. SAP2000, Computers and Structures, Inc. 2012.
7. Bell, Trudy E. "Moonquakes." NASA - National Aeronautics and Space Administration. NASA, 2006.

Engaging Undergraduate Students into Advanced Earthquake Engineering Research

**Cheng Chen, Jose Valdovinos, Frank Sanchez, Nelly Avramova,
Hector Santillano and Robert Hartsock**

School of Engineering, San Francisco State University, San Francisco, CA

Abstract

Preparing undergraduate students for advanced studies is critical to enhance engineering education for future American workforce. This paper presents the engagement of undergraduate students into a two-year BRIGE project funded by National Science Foundation. The research project aims to establish a reliability assessment approach for real-time hybrid simulation with the presence of actuator delay during the test. Real-time hybrid simulation has been widely considered the most effective and efficient alternative for shake table test to accommodate rate-dependent behavior within large-scale civil engineering infrastructures. Research is urgently needed for reliability assessment of experimental results of real-time hybrid simulations. A total of five undergraduate students were recruited with varying knowledge background in earthquake engineering. To involve these students into research activities, they were provided introductory lectures on structural dynamics and real-time hybrid simulation. Numerical model using Matlab and Simulink is created to emulate nonlinear structural behavior under selected ground motions. The students were instructed to conduct computational simulations of a nonlinear structure using recorded ground motions from PEER strong motion database and to interpret the simulation results to analyze the effect of actuator delay in real-time hybrid simulation. These engagement activities of undergraduate students have been demonstrated very effective preparing the undergraduate students for the further study to accomplish the project objectives.

Introduction

In 2010 the Committee to Assess the Capacity of the U.S. Engineering Research Enterprise published a report indicating that engaging students in engineering research is essential for our nation's competitiveness and long-term productivity in a global, knowledge-driven economy¹. To achieve this objective, the National Science Foundation (NSF) provided the Broadening Participation Research Initiation Grants in Engineering (BRIGE) program which intends to increase the diversity of researchers in the engineering disciplines. The goal of the BRIGE program is to support innovative research and diversity plans that contribute to recruiting and retaining a broad representation of engineering researchers especially those from groups that are underrepresented in the engineering population². In 2012, the project titled "Reliability Assessment of Real-Time Hybrid Simulation Results for Performance Evaluation of Structures under Earthquakes" led by first author was funded by NSF to develop a probabilistic approach to assess the reliability of experimental results using the real-time hybrid simulation technique for replicating actual structural responses during earthquakes. To accomplish the project objectives, a total of five undergraduate students are recruited at San Francisco State University (SFSU). This paper presents the engagement of these five undergraduate students into an on-going two-year BRIGE project.

SFSU is one of the 23 campuses of the California State University system and one of the nation's most ethnically and culturally diverse master's-granting universities. With a total enrollment of 29,718 in fall 2010, SFSU is the 51st largest university in the country³ and ranks 14th in the nation in awarding undergraduate degrees to minorities⁴. Of the 29,718 enrolled students, who reported their ethnicity in fall 2010, 37.2% were from underrepresented minority (URM) groups including 21.5% Latino; 5.9 % African American; 0.8 % Pacific Islander and 0.4% Native Americans. The students in the School of Engineering are equally ethnically, culturally, academically, and economically diverse. About 15% of the School's students are women and 78% are students of color (33% Asian, 20% Filipinos and Pacific Islanders, 16% Hispanic, 8% Black, and 1% Native Americans). The diverse student body at SFSU provides an ideal environment to accomplish the goal of the NSF BRIGE program.

The research objectives of the funded BRIGE project are: 1) Analyze the effect of actuator delay on accuracy of real-time hybrid simulation involving single or multiple actuators. 2) Conduct correlation analysis between actuator delay and simulation accuracy based on numerical analysis results. 3) Incorporate the probability model to develop probability-based criteria for reliability assessment of real-time hybrid simulation results. 4) Validate the effectiveness of the reliability assessment approach by applying it to experiment results from real-time hybrid simulations. Along with these research objectives, this BRIGE project also aims to: 1) create a diverse research group at SFSU to provide student researchers with meaningful research experiences and prepare them for engineering careers; 2) develop learning modules on earthquake engineering and involve student researchers into state-of-the-art earthquake engineering research so as to prepare them for their future more advanced degrees; 3) provide student researchers opportunities to participate and present at engineering conferences.

Challenges for Engaging Students into Research Activities

Laboratory experiments play a critical role in earthquake engineering research. Devastating structural damages and loss of human lives in recent earthquakes in Christchurch New Zealand⁵ and Tohoku Japan⁶ call for advances in research on seismic resilient infrastructures. Numerical simulations have inherent limitations due to the simplification of complicated force-deformation relationships within engineering structures. Laboratory experiments therefore play a critical role by enabling immediate evaluation of structures under simulated earthquake loading and by providing data to calibrate numerical models. Findings from laboratory experiments not only replicate the damage and failure of structures during earthquakes, but also provide the most effective means for the earthquake engineering profession to understand and utilize new technologies to engineer structures that withstand earthquakes. Real-time hybrid simulation technique⁷⁻¹⁰ divides the simulated structure into: (i) experimental substructures to be physically tested in laboratory, and (ii) analytical substructures to be numerically modeled. Typically, although not always, not well understood key components of the structure are physically tested as experimental substructures in the laboratories, while well-behaved parts are numerically simulated as analytically substructure in computer programs. A numerical algorithm is used to integrate the substructures and solve the structural dynamics in a step-by-step manner. The dynamic response of civil engineering structures, especially those in which complex nonlinear behavior is expected to occur in only a few locations, can therefore be simulated realistically and cost-effectively at large- or full-scale in the size limited laboratories. Figure 1 depicts a typical

application of the real-time hybrid simulation technique, in which the energy dissipating devices are isolated as experimental substructures, and the steel moment resisting frame (MRF) is modeled analytically. Real-time hybrid simulation therefore represents the state-of-the-art research activities in earthquake engineering. The funded BRIGE project therefore provides a unique opportunity for students at SFSU to have meaningful research experience in the field of advanced earthquake engineering. Along with this also come the challenges to engage students at SFSU to understand the technical background and to produce meaningful results.

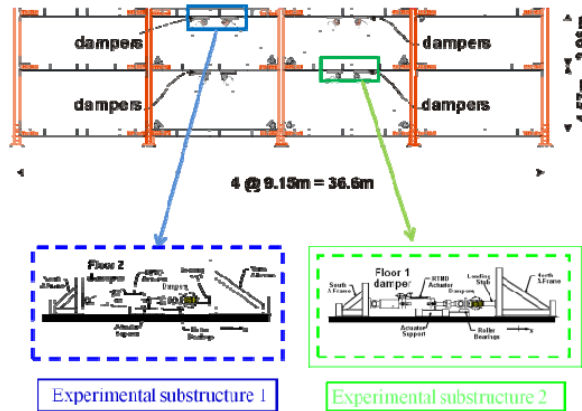

Figure 1. Real-time hybrid simulation of MRF with energy dissipating devices

With the support of NSF funding, a total of five undergraduate students at SFSU were recruited for the BRIGE project. Three of them are seniors and the other two are juniors. One is female and three of them are Hispanic students. As to the academic background, two of the five student researchers have finished the fundamental engineering course on structural dynamics and vibration, while another two were taking the course concurrently during the previous spring semester. During the first few weeks, the PI met the students twice a week to provide introductory lectures to the student researchers. These lectures focus on fundamentals of the BRIGE project including MATLAB¹¹ programming, structural dynamics and nonlinear structural behavior. For example, the nonlinear behavior considered in this project is emulated using the Bouc-Wen model¹², which is mathematically expressed by several differential equations. To help the students to understand and to be able to simulate nonlinear single-degree-of-freedom structure when subjected to selected ground motion, a Simulink model is developed as shown in Figure 2. After each lecture, the student researchers were required to make slight modifications to the MATLAB script to incorporate the varieties in ground motions, properties of SDOF structure and time delays. After four-week lectures, the students researchers started to understand the concept of real-time hybrid simulation, nonlinear structural behavior and computational simulation using MATLAB and Simulink¹¹.

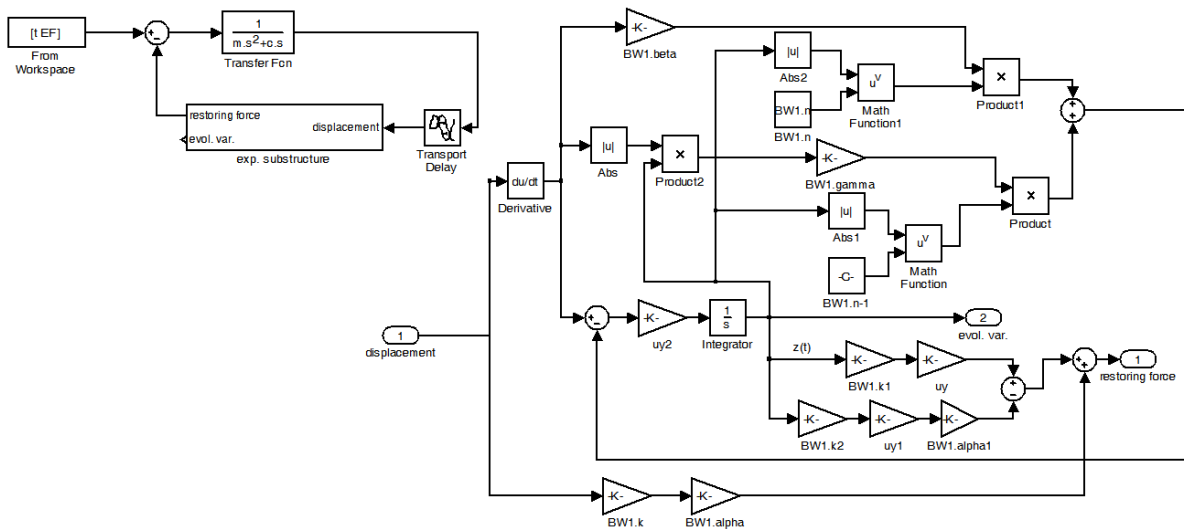

Figure 2. Simulink model for computational simulation of structural response under earthquakes

Another challenge is how to actively involve the recruited students into the research activities. All the student researchers have taken the PI's class in the past and the recruitment is based on academic standing and motivation. Around ten students have contacted PI for research opportunities and five of them are finally selected. To facilitate discussion, the students are divided into several groups working on different research topics. During the first semester, it has been shown that it is quite difficult to motivate all the recruited to devote themselves to the project. Two major issues exist: 1) Time management. During the junior and senior years, the students often take fourteen to sixteen units classes and also have part-time jobs ranging from 10 to 15 hours per week. It is difficult to have the students finish the assigned research tasks in time. 2) Financial support. The NSF funding provides an hourly rate of \$11 for student researchers and a maximum of 20 hours per week. This is not comparable with internship payment. It is difficult provide enough financial support to students researchers to concentrate on the project.

Project Research Outcome

The research experience during the first semester (September to December 2012) enabled the student researchers to develop fundamental concepts about the BRIGE project, involve in state-of-the-art earthquake engineering research for the first time during their undergraduate study. Student researchers meet weekly with their supervisor to discuss their progress on their research and provide feedback on what they can achieve. The student researchers will need to balance between their course work and research task which helps them develop time management capability for their future career. The research activities have led to a peer-reviewed conference paper in Structures Congress¹³ and two other publications are being submitted.

Figure 3 shows the computational simulation results for the effect of different ground motion inputs on the accuracy of real-time hybrid simulations with actuator delay including the ground motions recorded during the 1994 Northridge and 1995 Kobe earthquakes. The SDOF structure is assumed to be linear elastic. It can be observed that for the same amount of delay, different ground motions will lead to different values of maximum error. The student researchers are

guided to conduct for computational analysis which further demonstrated that the actuator delay for given accuracy measure in terms of maximum error varies for different ground motions.

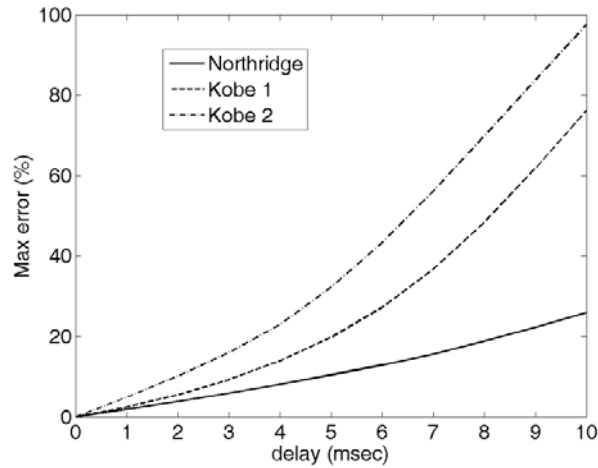

Figure 3. Effect of actuator delay on real-time simulations with different ground motions¹³

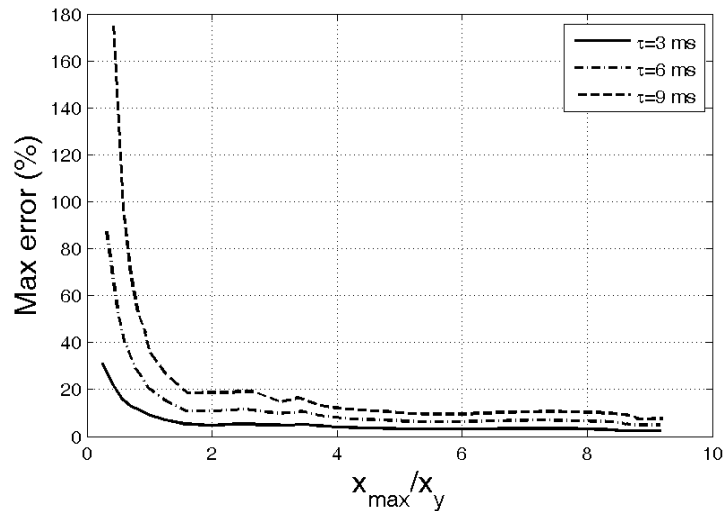

Figure 4. Effect of actuator delay for different ductility demands¹³

The students were further guided to analyze the effect of nonlinear behavior on the accuracy of real-time hybrid simulation results. Figure 4 shows that the maximum error for real-time hybrid simulations of a SDOF structure decreases with the increase of the ductility demand when the time delay is 3 ms, 6 ms and 9 ms, respectively. The yield displacement of the SDOF structure is 24.8 mm. The scale of the ground motion is gradually increased to achieve larger values of x_{max}/x_y . For the case of time delay equal to 3 ms, the maximum error in simulated response decreases from 9.37% for x_{max}/x_y equal to 1.0 to 4.22% for x_{max}/x_y equal to 3.2. Similar observation can also be made for the cases of time delay equal to 6 ms and 9 ms. Figure 4 reveals that for the same actuator delay, the maximum error of a real-time hybrid simulation involving nonlinear behavior could be estimated based on that for corresponding linear elastic structure by considering the ductility demand imposed on the SDOF structure.

Figure 5 shows an exploratory study by a student researcher on smart hybrid simulation [#]. Modeling errors are introduced into the analytical substructure parameters. The simulated response with modeling error is compared in Figure 5(a) with the exact structural response to demonstrate the detrimental effect. The error in simulated response in Figure 5(b) could reach 25% of maximum structural response. Figures 5(c) to 5(d) show the synchronized subspace plot between the restoring forces from the experimental and analytical substructures. Figures 5(f) to 5(h) demonstrate the effectiveness of modeling accuracy indicator (MAI) for assessing the accumulative error in restoring force due to the modeling error.

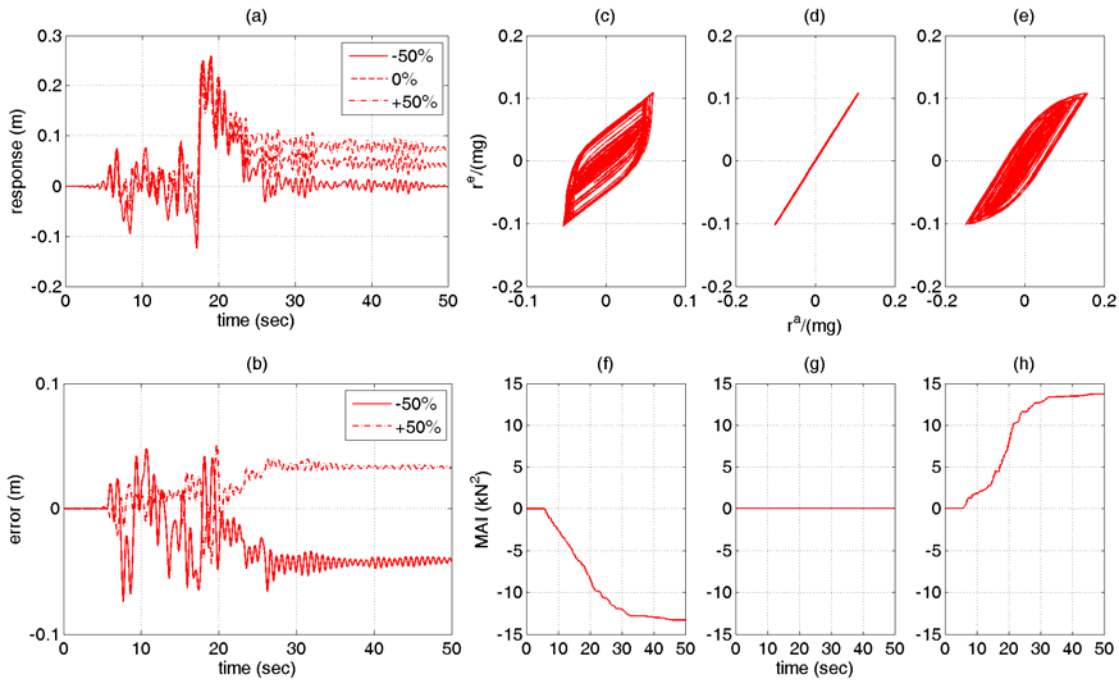

Figure 5. MAI for effect of error in yield displacement¹⁴

Summary and Conclusion

The NSF funded BRIGE project has been successful in engaging five undergraduate students at SFSU into state-of-the-art earthquake engineering research on real-time hybrid simulation. During the first semester, the project has helped the student researchers understand earthquake engineering topics. Under the supervision, the students have contributed to two peer-reviewed conference publications to demonstrate the success of this project engaging undergraduate students into engineering research.

Acknowledgement

This research was supported by the National Science Foundation under the award number CMMI-1227962. The author would also like to acknowledge the support from the California State University Wang Family Faculty Award and San Francisco State University Presidential Research Award. Any opinions, findings conclusions and recommendations expressed in this paper are those of the author and do not necessarily reflect those of the sponsors.

References

1. Engineering Research and America's Future: Meeting the Challenges of a Global Economy. 2005. Committee to Assess the Capacity of the U.S. Engineering Research Enterprise, National Academy of Engineering of the National Academies, The National Academies Press, Washington, D.C.
2. http://www.nsf.gov/funding/pgm_summ.jsp?pims_id=503160
3. Chronicle of Higher Education, Almanac Edition. 2011. Campuses with the Largest Enrollments. , last accessed 01/10/2012.
4. Diverse Issues in Higher Education. 2011. Top 100 undergraduate degree producers. last accessed 01/14/2012.
5. Tohoku Earthquake, Japan (2011), http://en.wikipedia.org/wiki/2011_Christchurch_earthquake
6. Christchurch Earthquake, New Zeland (2012).
7. Blakeborough, A., Williams, M.S., Darby, A.P. and Williams, D.M., 2001. "The development of real-time substructure testing." Philosophical Transactions of the Royal Society of London A, 359:1869-1891.
8. Shing P.B., 2002. "Development of high-speed on-line substructuring testing system at the University of Colorado." CASCADE Technical Workshop, Oxford, UK.
9. Bonnet, P.A., Lim, C.N., M.S. William, Blakeborough, A., Neild, S.A., Stoten, D.P. and Taylor, C.A., 2007. "Real-time hybrid experiments with Newmark integration, MCSmd outer-loop control and multi-tasking strategies." Earthquake Engineering and Structural Dynamics, 36(1):119-141.
10. Chen, C., Ricles, J.M., Marullo, T.M. and Mercan, O., 2009a. "Real-time hybrid testing using the unconditionally stable explicit CR integration algorithm." Earthquake Engineering and Structural Dynamics, 38(1):23-44.
11. MATLAB, Mathworks Inc., 2012.
12. Wen, YK. Equivalent linearization for hysteretic systems under random excitation. Journal of Applied Mechanics, Transaction of ASME, 1980; 47:150-154.
13. Chen, C. and Valdovinos J., and Santillano H. (2013), "Reliability Assessment of Real-Time Hybrid Simulation Results for Seismic Hazard Mitigation," Structures Congress 13, May 2- 4, Pittsburgh, PA.
14. Chen, C., Avramova, N.B., and Pong, W.S. (2013), "An Assessment tool for Quantifying Cumulative Effect of Modeling Errors for Smart Hybrid Simulation," 11th International Conference on Recent Advances in Structural Dynamics, July 01-03, Pisa, Italy.

Work In Progress: Stepping Back and Letting Students Take the Lead – Student-led Projects for a First-Year Introduction to Engineering Course

Matthew T. Siniawski¹, Adam R. Carberry², Nazmul Ula¹

¹ - Loyola Marymount University / ² - Arizona State University

Abstract

A first-year introduction to engineering course was redesigned to encourage active learning through a project-based pedagogy. A major goal of this approach was to improve students' engagement, learning, and interest in pursuing an engineering career. Student teams participated in four unique engineering projects throughout the course. Each project varied the degree to which the instructor defined the project goal, the specific project requirements, the schedule, the project deliverables, and the project-grading criterion. Some projects were completely defined by the instructor, while some projects gave freedom to the students in defining various project aspects. This paper will discuss student preferences toward the level of freedom given to them in defining various aspects of the projects.

Introduction

Students in a first-year introduction to engineering course at a small private university in the southwest completed various team-based projects throughout the term. The course included four sections enrolling a total of 118 students. Students in two of the course sections were asked to participate in this study.

Both course sections required student teams of 3-4 students per team to work on a total of four unique projects throughout the term. Projects included building and testing mousetrap vehicles, popsicle stick bridges, catapults, solar ovens, and programmable robots. Projects typically lasted 2-3 weeks per project and often allowed time for design iterations and re-testing. Each project varied the degree to which the instructor defined the following:

1. Selecting the project
2. Defining the project requirements
3. Setting the project schedule
4. Determining the project deliverables (e.g., reports, presentations, etc.)
5. Determining the project-grading criterion.

Some projects were completely defined by the instructor, while some projects gave freedom to the students in defining the various project aspects.

Research Methods

Our study consists of a one-phase analysis regarding students' conceptions of working on various aspects of the first-year introduction to engineering design projects. Students were asked at the end of the course to indicate their preference toward instructor-defined or student-defined project aspects regarding three constructs: *student engagement*, *student learning*, and *interest in*

pursuing and engineering career. Each construct was assessed using a scale that allowed students to reflect on the five activities previously listed, i.e. *selecting the project, defining the project requirements, setting the project schedule, determining the deliverables (e.g. reports, presentations, etc.), and determining the project-grading criterion.*

Students selected their preference for each item using a sliding scale from zero to 100, where 0 = instructor-defined and 100 = student-defined. The questions were designed to identify student preferences in defining the various design project activities and if any differences arose regarding their conceptions of engagement, learning, and their interest in pursuing an engineering career. Post-conceptions were recorded immediately after the conclusion of the course. No pre-conceptions or comparison group data was collected.

Findings and Future Work

Of the 61 students enrolled in the two experimental course sections, 66% of the students (N=40) completed the survey. The mean preferences of the students are displayed in Figure 1. The error bars are the standard deviations of the results and represent the wide range of students' responses.

Overall, the majority of the students most preferred selecting the project, determining the deliverables, and defining the project requirements. For all five questions, the student preferences had the highest influence on their interest in pursuing engineering. These results will be used as a foundation to effect change in the first-year engineering courses as a path to impact student retention. Future work will determine changes in student preferences based on pre-post comparisons. In addition, experimental data will be compared to comparison groups.

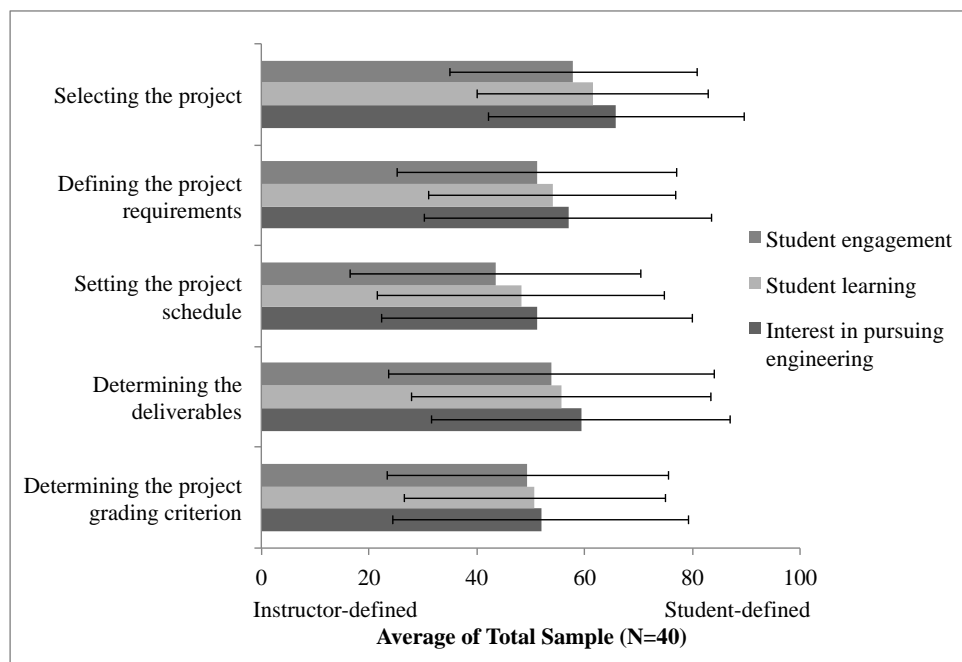

Figure 1. Resulting average preferences of the students (error bars are the standard deviations of the results).

A Project-based Approach for a Design and Manufacturing Laboratory Course

Matthew T. Siniawski¹, Adam R. Carberry², Rafiqul I. Noorani¹

¹ - Loyola Marymount University / ² - Arizona State University

Abstract

An upper-division design and manufacturing laboratory course for mechanical engineering students was redesigned to incorporate a semester-long project. The goal of the project was to provide students with an experience applying the design process to develop a simple product, a manual bottle opener. During the design process, students individually generated a conceptual design, created a 3D computer-aided design (CAD) model of their design incorporating appropriate design for manufacturing (DFM) guidelines, created a rapid prototype (RP) model of their design, and conducted relevant analyses to ensure reliability and functionality. The initial project design concluded with each student pitching his or her product idea to the entire class. The ‘winning’ design was determined by a class vote. The entire class then worked to manufacture CNC milled prototypes of the winning design. This paper will discuss the details of the design project and a qualitative assessment of the students’ responses.

Introduction

This project is the result of a desire to improve the learning process of design for manufacturing (DFM) guidelines and practices. The overall goal was to provide a practical, active learning environment that engages students in the design and manufacturing process of a simple consumer product. Similar efforts have been conducted in the past in order to improve student learning and engagement. For example, practice-based curricula and physical facilities have been developed specifically to focus on student engagement with the product realization process¹. Undergraduate courses for mechanical engineering students that provide students with hands-on experiences in design and manufacturing have proven beneficial, especially in regards to technical communication abilities and preparation for completion of their capstone projects².

Integrative approaches to design and manufacturing are typically dealt with in senior electives, capstone projects, or graduate courses. This course and project were both created with the goal of providing our undergraduates with an integrated experience of the design and manufacturing process in order to better prepare them for their capstone project courses. Our research explores students’ conceptions of and ideas associated with design and design for manufacturing guidelines. We therefore ask the following question: ‘what are students’ conceptions of learning design and manufacturing principles in the context of working on an integrated design and manufacturing project?’

Course Structure

Our undergraduate program, like many others, contains courses in design, manufacturing and computer-aided design (CAD) and concludes with a yearlong capstone project. A required two-unit laboratory course was designed in order to provide an integrated experience of design and

manufacturing prior to the capstone project. Students currently enroll in this course during the fall semester of their senior year while concurrently enrolled in the first semester of their yearlong capstone project. Two sections of this course are typically offered every fall semester.

The course introduces design for manufacturing (DFM) guidelines and common tools used in product development. Students complete numerous design and manufacturing activities, complete a comprehensive design and manufacturing project, and prepare various technical reports. The general topics covered in the course include design for manufacturing (DFM) guidelines, dimensional accuracy, rapid prototyping, NC programming and CNC machining equipment, design of experiments (DOE), and preparing technical reports. The learning outcomes that were established for this course include:

1. *Designing components based on design for manufacturing (DFM) guidelines.*
2. *Creating design prototypes using rapid prototyping (RP) and CNC machining.*
3. *Communicating laboratory experimental findings and relevant design information in technical reports.*

Throughout the duration of the course, students are continuously working on various aspects of the bottle opener design project. In addition, focused lectures and laboratory experiments are included that reinforce a variety of the design project aspects. For example, the students participate in a two-week long experiment to determine the shrinkage factor for the rapid prototyping machine that they will use later on for their project. In addition, the students participate in a two-week long experiment involving NC programming and commercially available computer aided manufacturing (CAM) software prior to working on having their designs machined.

Design Project Details

Overall Design Project Requirements

For this semester-long project, each student was asked to design and create a handheld bottle opener of his or her own design. The instructor chose a bottle opener as the product primarily because of its relatively low manufacturing costs and short production time and the potential interest from students. In addition, simple analyses of stresses and deflections could easily be included with the integrated design and manufacturing work. The project was structured into four major phases: 1) design concept selection, 2) design for manufacturing, 3) design analysis and initial prototyping, and 4) final prototyping. In line with these four phases, each student was required to:

1. *Create multiple design concepts, evaluate them, and select one design concept*
2. *Generate a 3D CAD model of the selected design concept that incorporates design for manufacturing (DFM) guidelines*
3. *Conduct relevant failure analyses to ensure reliability, produce an initial prototype using a rapid prototyping machine, and modify the design based on analysis and testing results of the initial prototype*

4. Manufacture a final revised prototype using a CNC milling machine

Each student was required to participate in two individual ‘sit-and-spin’ CAD design reviews with the instructor, where the students show and discuss their 3D CAD models, and complete three intermediate design reports. In addition, a comprehensive design intent document was due at the end of the semester. Detailed information regarding the requirements for each of the major project phases and the requirements for each report were provided.

Both function and form were considered throughout the duration of this project. The design had to work properly and repeatedly, as well as have a simple, yet aesthetic form. The final prototype was required to be made out of a non-corrosive metal, smaller in volume than 6 in. x 2 in. x 1 in., and relatively simple to machine using a CNC mill (two or less machining directions). The stock material used to manufacture the final prototype was limited to a cost of \$20 (excluding taxes, shipping and handling).

Phase 1: Design Concept Selection

Students conducted a study of similar products in order to come up with a few different conceptual designs. They performed some relevant evaluation in order to select one of the design concepts, with the instruction to keep in mind that ‘the best design is usually the simplest.’ They create scaled, clear, and labeled hand drawn sketches that depicted three different views of their final selected design concept. The relative dimensions were shown, but did not include dimension specific features. A short report was required that included a discussion of their different conceptual designs, the design concept evaluation methods, a description of the selected design, and their design concept sketch.

Phase 2: Design for Manufacturing

Students created a 3D CAD model of their selected design concept using SolidWorks®. Their model was required to incorporate design for manufacturing (DFM) guidelines for machined parts. They were told to remember that their design must be relatively simple to machine using a CNC mill (requiring two or less machining directions). Once their design model was created, students were then tasked with producing a complete 2D drawing of their part using SolidWorks®. They were asked to only use as many views as needed to communicate the design. All features on their 2D drawing were to be dimensioned properly, including appropriate placement, decimal places, and tolerance. Students were informed to keep in mind that ‘the best design is tolerant of variations’ and to not call out tight tolerances when unnecessary.

Each student participated in a design review during this project phase in which they lead a sit-and-spin CAD review of their part. During this review, they discussed how the part will be machined using a CNC mill. Specifically, they were asked to be prepared to discuss the number of setups, what operations will be performed from which direction(s), and to provide detailed information such as the type and stock size of the material, the size of the cutters and drill bits, etc. They were required to bring copies of their 2D drawing to the review and discussed the called out dimensions and tolerances. Finally, they were asked to turn in any supporting documentation as necessary that will help communicate their design.

A short report was required that included a discussion of how their part will be machined using a CNC mill. Specifically, they were required to discuss the number of setups and what operations will be performed from which direction(s). They were informed to be detailed in their discussion, including information such as the stock size of the material, the size of the cutters and drill bits, etc. If necessary, they included labeled images of their 3D CAD model in order to support their discussion. Finally, students were required to include their 2D drawing with this report.

Phase 3: Design Analysis and Initial Prototyping

Students were asked to develop a theoretical model for their design and analyze the stresses and factor of safety. They validated their theoretical analysis with computational analyses using the SolidWorks® Simulation add-in. The students made necessary design changes based on their analyses and updated their 2D drawings. Finally, they created a physical initial prototype of their design using a rapid prototyping machine.

Each student participated in a second design review during this project phase. During this review, they discussed how they analyzed their design and what conclusions they were able to make from the results. In particular, they were required to discuss the loading conditions that were considered, how the loads were applied, the key results of the theoretical and computational analyses, how the results compared, and any design changes that were made as a result of the analyses.

Students completed a third short report that discussed how their part was analyzed and the results of the analyses. In particular, they were required to discuss the loading conditions that were considered, the key results of the theoretical and computational analyses, how the results compared, and any design changes that were made as a result of the analyses. Students also provided an updated 2D drawing and a bill of materials (BOM) with the report.

Phase 4: Final Prototyping

Instead of each student working to produce a CNC milled prototype of their unique design, the students voted on a single ‘winning’ design for each class section. Each student pitched their design idea to the class section and the students voted to select a single design that would be manufactured. Each student received a final CNC milled prototype of the ‘winning’ bottle opener design. Small student groups then used GibbsCAM® computer-aided manufacturing (CAM) software and worked with the laboratory technician to create the necessary programming to produce the design using a 3-axis CNC mill.

Students were also required to create a detailed design intent document for their individual bottle opener design. Students were provided with a design intent document template and examples of design intent documents for other products. The main purpose of the design intent document is to communicate the designer’s thought process and decisions for arriving at the final design. The major sections of the design intent document included: 1) a general description of the product and its basic function, 2) a detailed description of the major features of the product, 3) a detail description of the design, including conceptual design development, evolution and iterations of

the design, and results of the analyses, 4) a discussion of functionally critical dimensions and a tolerance analysis, and 5) a discussion of the issues with the design and potential future changes. A 3D CAD image from the design intent document and a picture of the final CNC milled part for one of the ‘winning’ designs are shown in Figure I. The form of this particular design was in the shape of a silhouette of a lion, our university mascot. The bottle cap is opened using the teeth of the lion (shown as features 2 and 3 in Figure IA).

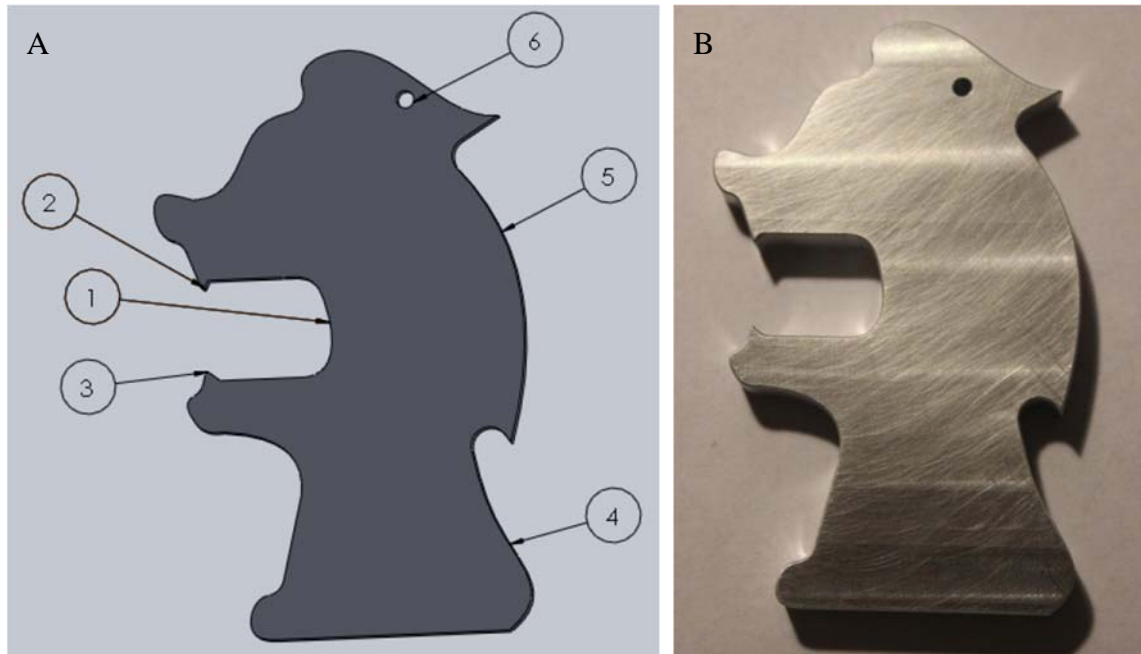

Figure I. One of the ‘winning’ bottle opener designs. A) 3D CAD image from the design intent document indicating various features, and B) the final CNC milled part.

Research Methods

Our study consists of a one-phase analysis regarding students’ conceptions of the design and manufacturing project. Students were asked at the end of the course to reflect on and respond to two open-ended questions regarding their conceptions of learning design and manufacturing:

1. Describe what you learned about design and manufacturing as a result of working on the bottle opener design project.
2. Describe the aspects of the bottle opener design project that you most and least liked and why.

The questions were designed to identify general conceptions of learning about the design and manufacturing process and their opinion of the bottle opener design project. Post-conceptions were recorded immediately after the conclusion of the course.

An open-coding approach was taken to identify emergent categories in the data³⁻⁴. A single rater first read each student’s response to determine a set of categories compiled into a rubric. The rubric was then used to code each student’s response. A second rater then used the rubric to test

its reliability across raters. The second rater repeated a two-step process consisting of 1) coding 10 percent of the responses using the rubric, and 2) consulting the first rater’s codes, until agreement was reached. Changes to the rubric were made to establish a high inter-rater reliability between the two raters.

Six learning area codes emerged from the data for question one (Table I). *Applied Process* included statements regarding applying the design process firsthand and learning how to design is challenging. *CAE Software* included references to the use of CAD/CAM software for design and manufacturing purposes, creating 2D drawings, and geometric dimensioning and tolerancing (GD&T). *Decision Making* represents considerations that must be made in regards to the project requirements and compliance with DFM guidelines. *Design Iterations* represent geometric design and material revisions based on analysis and testing results. *Physical Prototyping* represents the physical development of design concepts using rapid prototyping and machining. The final code, *Project Management*, involves communication, documentation of the design process and intent, and time management.

Table I. Question 1 codes and examples.

Code	Example(s)
Applied Process	<p><i>“The process of making designs and refining these designs can only be taught through experience and trial.”</i></p> <p><i>“I learned that there are a lot of unforeseen difficulties associated with building a part from scratch like this.”</i></p>
CAE Software	<p><i>“I learned how to make a CAD model from just a simple concept drawing.”</i></p> <p><i>“I learned how to build a part using CAM and CAD and how they communicate with each other.”</i></p>
Decision Making	<p><i>“There are many considerations to be made simultaneously to progress in a productive manner.”</i></p> <p><i>“The requirements were key for learning how to break down the design process into its most essential pieces.”</i></p>
Design Iterations	<p><i>“I learned how to analyze high risk features of the design and respond with the appropriate changes.”</i></p> <p><i>“Detailed analysis of components helps validate and explain decisions.”</i></p>
Physical Prototyping	<p><i>“The rapid prototype (sample) was extremely useful.”</i></p> <p><i>“I learned about CNC machining and the importance of rapid prototyping.”</i></p>
Project Management	<p><i>“I learned the importance of communicating with the machinist.”</i></p> <p><i>“I learned how to communicate my (design) intent and document my progress on a design project effectively.”</i></p> <p><i>“We had to consider rapid prototyping production and CNC milling time.”</i></p>

Seven unique codes were identified for question two. For organizational purposes we have identified the codes that the students indicated they most liked or least liked (Table II). Some of the codes for question two were the same that were identified for question one and described above. *Concept to Final Product* included specific statements regarding taking a design from a concept on paper to a final physical product. *Creative Freedom* represents the freedom and flexibility that the students were given during the project. Finally, *One ‘Winning’ Design*

included references to the fact that only one design concept was selected for final CNC prototyping.

Table II. Question 2 codes and examples.

Code	Most Liked	Least Liked	Example(s)
Applied Process	☐		<i>“I liked that it taught us the fundamentals of the design and manufacturing process.”</i>
Concept to Final Product	☐		<i>“Seeing a design go from an idea to a usable object is amazing and is what engineering is about.”</i>
Creative Freedom	☐		<i>“I liked the freedom to create my own unique design.” “I most liked the flexibility and independence of the project.”</i>
Design Iterations	☐	☐	<i>“Iterating my design concepts to fit design-for-manufacturing standards was a fun challenge.” “The revisions became a little tedious with such a simple design.”</i>
One ‘Winning’ Design		☐	<i>“I disliked how at the end we were unable to each get our own design produced.”</i>
Physical Prototyping	☐		<i>“I like the prototyping because it gave me a physical model of the part I had spent time designing.”</i>
Project Management	☐	☐	<i>“It ended up teaching me time management skills.” “A write-up after each step was a bit unnecessary.”</i>

Findings and Discussion

Our findings include a post analysis of our experimental group. The number of students referring to each category for the post-survey is displayed in Figures 1 and 2. Responses were coded by assigning a value of one when a code was present and zero if a code was not. An overall inter-rater reliability of 90% was obtained between the two raters.

As shown in Figure 1, the majority of students (60%) indicated that they learned that design is an **Applied Process**, meaning that design is challenging and is best learned firsthand. In addition, the majority of students (60%) indicated that they learned about **Physical Prototyping** and the physical development of design concepts using rapid prototyping and machining. Finally, a significant number of students (50%) also learned about the importance of **Design Iterations**, especially geometric design and material revisions based on analysis and testing results.

According to Figure 2, the majority of students (50%) of students indicated that they most liked the **Creative Freedom** they were given with this project. In addition, 45% of students indicated that they most liked the **Applied Process** aspect of this project. Finally, 35% of students indicated that they least liked that only **One ‘Winning’ Design** concept was selected for final prototype fabrication.

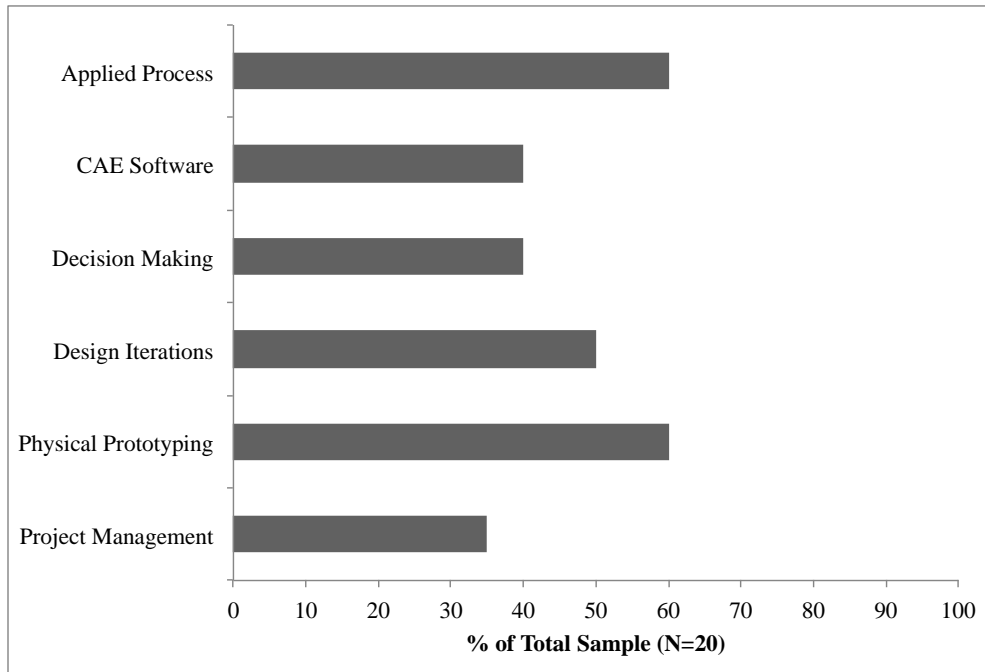

Figure 1. Percentage of students from the post analysis identifying each category as something they learned about design and manufacturing as a result of working on the bottle opener design project.

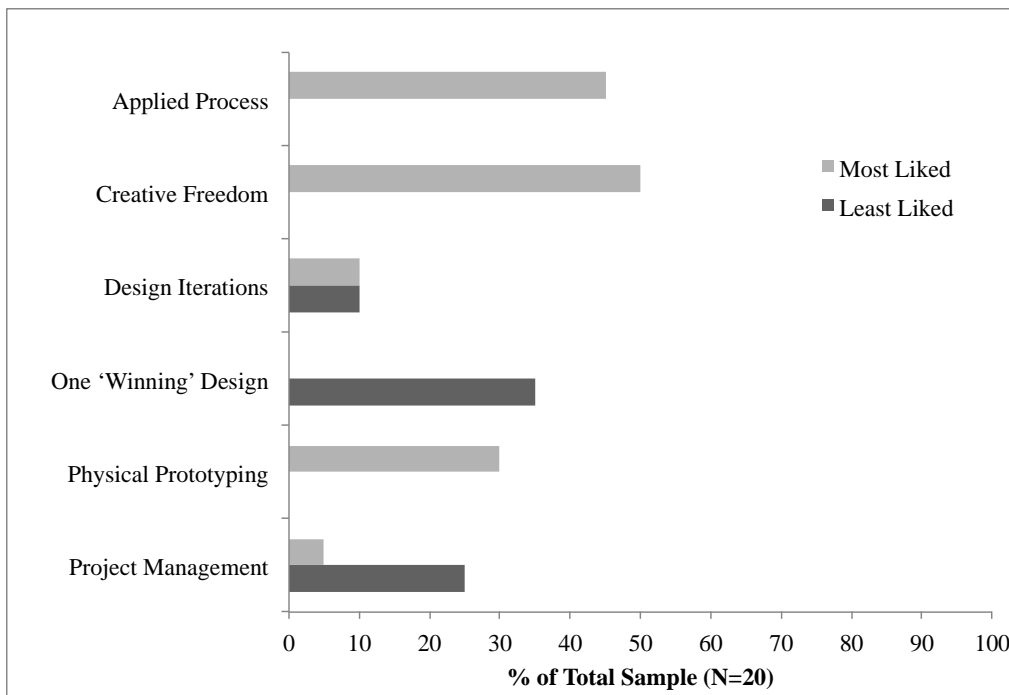

Figure 2. Percentage of students from the post analysis identifying each category as something that they either most liked or least liked about the bottle opener design project.

Conclusions, Implications, and Future Work

Design is an important part of the engineering process. Our initial findings suggest that students both learn and like learning about design and manufacturing through direct application. Our findings indicate that students learn multiple skills while working on a semester-long design and manufacturing project. Student responses include recognizing that design is a process best learned through application. Students also indicated that they learned about physical prototyping and design iterations and appreciated the creative freedom they were given. Overall, students mostly liked learning these skills through this project, but mostly disliked not being able to fabricate a final CNC milled prototype of their own unique design.

While our work has provided useful insights, additional studies are needed to further investigate the conceptions of and ideas associated with design and design for manufacturing guidelines. Future changes to this project include replacing the smaller design reports with an ongoing, working design document report. In addition, the department is currently considering moving this course to the junior year to better prepare students for the capstone projects. Future studies of this project include determining changes in the emergent organizational categories from pre-post analysis. In addition, a comparison between our experimental group and comparison group will be conducted.

As we continue this research, we aim to shed light on how to teach design and manufacturing so that the implicit activities of design, i.e. the process, are given as much attention as the tools or products of design thereby helping students to develop more sophisticated conceptions of a core engineering skill.

Bibliography

1. Lamancusa, J.S., et al. (1997). The learning factory-a new approach to integrating design and manufacturing into the engineering curriculum. *Journal of Engineering Education*, 86, 103-112.
2. Dutta, D., et al. (2004). Introducing Hands-on Experiences in Design and Manufacturing Education. *International Journal of Engineering Education*, 20 (5), 754-763.
3. Glaser, B., and Strauss, A. (1967). *The discovery of grounded theory: Strategies for qualitative research*. Chicago, IL: Aldine.
4. Miles, M., and Huberman, M. (1984). *Qualitative data analysis: A source book for new methods*. Thousand Oaks, CA: Sage Publications.

Engaging Underrepresented Community College Students in Engineering Research

Hao Jiang¹, Jose Carrillo², Alam Salguero², Ellaine Talle², Enrique Raygoza², Xenia Leon², Ben Lariviere¹, Amelito G. Enriquez², Wenshen Pong¹, Hamid Shahnasser¹, Hamid Mahmoodi¹, Cheng Chen¹

¹School of Engineering, San Francisco State University, San Francisco, CA

²Cañada College, Redwood City, CA

Abstract

One of the effective methods to engage and excel underrepresented minority (URM) students in the STEM field is to “replace standard laboratory courses with discovery-based research”, as mentioned in the 2012 PCAST report [1]. Funded by 2012 NASA CIPAIR (Curriculum Improvements and Partnership Award for the Integration of Research) award, five underrepresented minority (i.e., 4 Hispanic and 2 female) students from Cañada College participate in a ten-week research of designing a world smallest power harvesting apparatus for implantable medical devices (IMDs). Two of the five students engage in circuit simulation using LT-Spice to predict the device’s performance. Two students are involved in programming the micro-controller, which controls the operation of the power harvest apparatus, and characterizing its performance. Another student designs and winds spiral coils that is used to harvest time-varying magnetic field. After students are familiar with the system, they are asked to improve the existing device by re-designing the electronic circuitry using the printed circuit board (PCB) technology altogether. At the last week of the summer project, they have the opportunity to characterize the device that is designed and made by students. During the ten-week summer research, students from Cañada College have the opportunity to experience entire engineering development flow: idea > design > prototyping > validation. In addition to learning the electronics design using the state-of-art electronic design automation (EDA) tool, the students are exposed to the challenges in designing electronic systems for biological systems. The interdisciplinary thinking could benefit their future STEM careers. The feedback from the students shows that the NASA CIPAIR is an effective method to engage URM students from community college in engineering research.

Introduction

Closing the persistent ethnic and racial gap among engineering students plays a pivotal role in reaching the goal proposed in the Engage to Excel by the President’s Council of Advisors on Science and Technology (PCAST) [1]: “producing, over the next decade, approximate 1 million more college graduates in STEM fields than expected under current assumptions”. In California, Hispanics make up about 37.6 percent of the total population [2], and only about 6 percent of the total engineers [3]. Increasing under-represented minority (URM) students in the STEM field will not only answer the call of producing more STEM graduates, but also improve the overall well-being of the society.

Recent reports [3, 4] indicate a great achievement gap among various ethnic groups. In California, only one in four students wanting to transfer or earn a degree/certificate did so within six years. African American and Hispanic students have even lower rates of completion; only 14% of African American students and 20% of Latino students completed a degree or certificate within six years, compared to 29% of white students, and 24% of Asian students. These low success and completion rates among URM students at community colleges are even more crucial since almost three-fourths of all Latino and two-thirds of all African-American students who go on to higher education begin their postsecondary education in a community college.

“Replacing standard laboratory courses with discovery research” is one of the five effective methods to engage and excel underrepresented minority students in the STEM field in the 2012 PCAST report [1]. However, in the community college setting, students are not exposed to STEM research. To facilitate community college students, especially those from underrepresented minority groups, to participate in STEM research, Cañada College, a Hispanic serving community college, joined forces with San Francisco State University, a four-year university with an active master program, to create an internship program that integrates underrepresented minority students into research. Supported by NASA 2012 CIPAIR program, five students joined the Electrical Engineering research program in SFSU.

The critical challenge to integrate community college students into research is to assign the activity at an appropriate level, so that students are actually involved in the research and make contributions. The approach here is to let students understand the research by pre-packaged computer simulations, and contribute to the project by hands-on tasks.

Project Background

The research project is to optimize an AC-DC boost converter for wireless powered miniaturized biomedical implants. Biomedical implants are highly anticipated by the medical community to dramatically improve the healthcare quality with the potential to lower the associated costs. Delivering electrical power to implants wirelessly has a profound impact on the implant's efficacy. Inductive coupling based wireless power delivery realized by two face-to-face coils has been the primary technology for the last several decades [5]. One of the critical challenges is that the receiving coil must be large enough (in cm range) so that its induced voltage can be significantly higher than the diode's turn-on voltage (about 400~700 mV in silicon technology). Otherwise, the power conversion efficiency (from the induced AC power to the usable DC power) is low [6].

The research group in SFSU has proposed a new approach to efficiently convert the received low-voltage AC power to a high-voltage DC power, when the induced voltage of the receiving coil is low (500mV when the coil is open). The operating principle of the proposed AC-DC boost converter is illustrated by a simplified circuit that handles the half period of the induced AC power, as depicted in Fig. 1 (a) and (b). In this particular design, the circuit operates the following three consecutive modes during half of the input AC period. First, the switch is turned on to short the receiving coil by itself, as depicted in the dashed line in Fig. 1(a). During this period, the induced current stores the magnetic energy into the coil. Second, the switch is off. Because the disruption of the coil current is dramatic, the receiving coil will generate a high

voltage across the receiving coil. The voltage across the coil is high enough to overcome the diode's turn-on voltage and the DC output voltage. Thus, a charging current is produced, depicted as the dashed-arrow in Fig. (1)(b). The charging current will only last for a very short time until the coil voltage is lower than the sum of the output voltage and the diode's turn-on voltage. At last, both the switch and the diode are off. The circuit waits for next charging. The operating principle of the circuit is similar to the traditional discontinuous conduction mode (DCM) DC-DC boost converter that raises a low voltage DC input to a high voltage DC output [7]. With this design, a very low induced voltage AC power at the receiving coil (500mV when the coil is open) can be converted into DC and raised to $>5V$ in DC. The ability of converting low-voltage AC power into high voltage DC can alleviate the requirement of large receiving coil. Thus, the receiving coil, which is the largest component in most implants, can be miniaturized without the sacrifice of the power conversion efficiency.

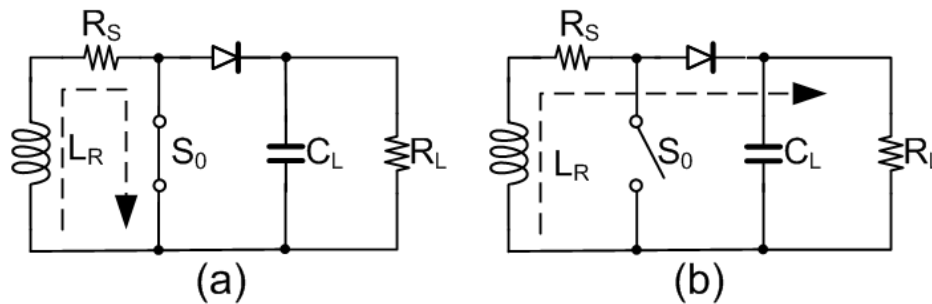

Figure 1: A simplified equivalent circuit to illustrate the operating principle. (a) energy storing mode, (b) charging mode

To validate the proposed circuit, a discrete components based electrical circuit is built, as shown in Fig. 2(a). The circuit diagram is shown in Fig. 2(b). A microcontroller that samples the input waveform using a separated auxiliary coil is used to produce the control signal for the main switch, S_0 . The measurement setup is shown in Fig. 3(a). Rotating permanent magnets is just a convenient way to generate a strong, low-frequency time-varying magnetic field to characterize the AC-DC boost converter [8]. The system is able to generate a magnetic field varying at 100 Hz. The disk magnet shown in Fig. 3(a) is made of neodymium iron boron (NdFeB) with 19 mm diameter and 3 mm thickness [9]. The hexagonal rotor driven by a DC motor [10] is made of steel so that all the disk magnets can be attracted to the surface. Each adjacent disk magnet has the opposite polarity. When the rotor rotates 60° , the receiving coil could experience the maximum variation of the magnetic flux. When the open-circuit induced voltage is as low as 500 mV, a $>5V$ DC output is produced as shown in Fig. 3(b).

Before the undergraduate research team join the research, the AC-DC boost converter, though have many jumpers on the board, is constructed by the graduate students. The characterization setup is also established. The project goal for the undergraduate research team is to (1) optimize the existing electronics to improve its performance by reducing the parasitics and its reliability by removing the jumpers; (2) carry out systematic measurements to fully characterize the proposed circuit.

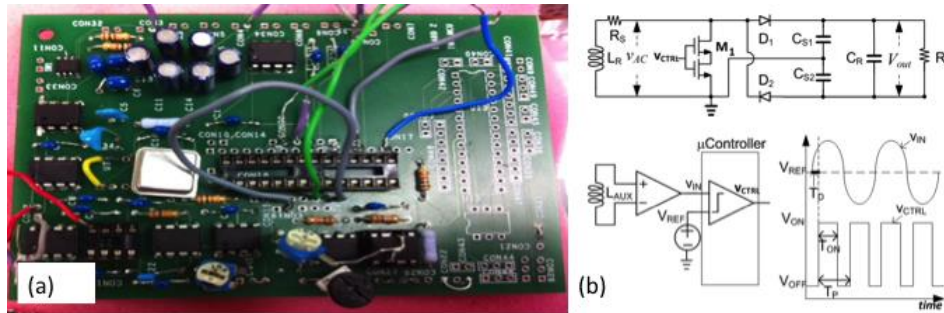

Figure 2: (a) The first circuit implementation of the proposed switching based AC-DC boost converter; (b) The circuit diagram of the boost converter

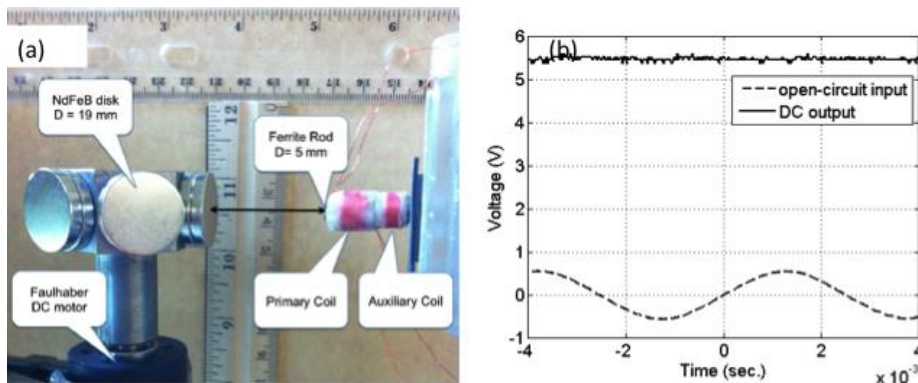

Figure 3: (a) the measurement setup; (b) input open-circuit AC and output DC.

Project Description

Five students (i.e., 4 Hispanic and 2 female) students from Cañada College participate in a ten-week research of designing a world smallest power harvesting apparatus for implantable medical devices. The project is divided into three phases

Phase 1: Understand the research project via computer simulations

All five students simulate the describe circuit using LT-SPICE [11], as shown in Fig. 4. By changing the value of each circuit component, students have thorough understanding of the AC-DC boost converter. The students are asked to present their findings after two weeks when they have exhausted all the possible design variation. Because computer simulations are able to illustrate the voltage of every node and the current of every branch, the exercise is an effective tool to help students understand the operating principle of the described AC-DC boost converter.

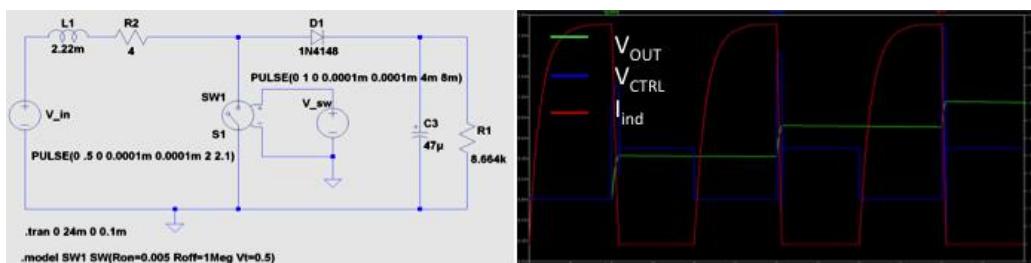

Figure 4: LTspice simulation, schematic and simulation results

Phase 2: Improve the existing circuit and the testing setup

Once students are familiar with the design, they are divided into three groups to work on the research. Group 1 (2 students) is to optimize the circuit, Group 2 (2 students) is to improve the measurement setup, and Group 3 (1 student) is to wind multiple coils to facilitate the characterization.

Group 1: Improve the existing circuit

The circuit shown in Fig. 2(a) has many redundancies and errors that are circumvented by jumper wires. The goal of the undergraduate research team is to improve the circuit design by reducing the redundancies and fixing all the wiring errors. As shown in Fig. 5, students create the new schematic and the layout of the described AC-DC boost converter.

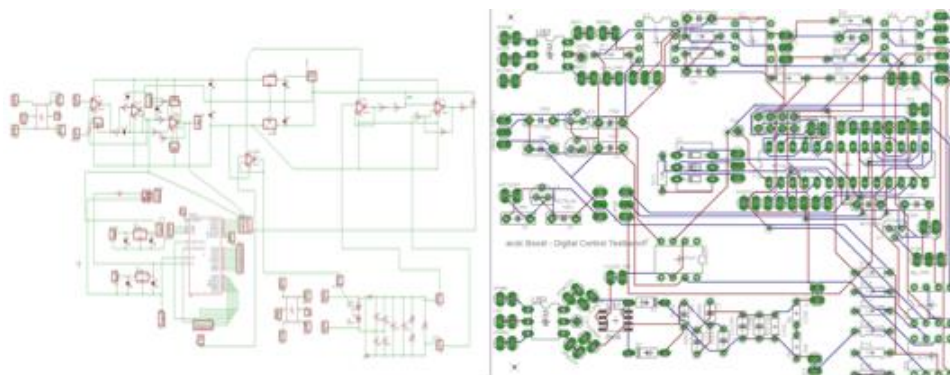

Figure 5: The schematic and layout of the AC-DC boost converter

Group 2: Improve the measurement setup

The measurement setup has been established before students join the research. However, the C-program that is used to produce the control signal from the microcontroller is not flexible enough to accommodate various testing modes. Two students in the undergraduate research team are asked to rewrite the original C-program so that it can dial out various duty cycle based on the original program. Because students are exposed to various programming language before, completing the task does not require a steep learning cliff.

Group 3: Design and wind inductive coils

One student is asked to wind various inductive coils to facilitate the test. The student is also responsible to measure the characteristics of an inductive coil.

Phase 3: Characterize the improved AC-DC boost converter

The improved AC-DC built based on the students' modification is used to fully characterize the circuit performance. In Fig. 6, the DC output is measured and plotted versus the duty cycle of the control signal that is applied to the main switch S_0 . Two coils are measured. Coil A has the inductance of 0.4 mH and the resistance of 1.2 Ohm, and Coil B has the inductance of 2.16 mH and the resistance of 4.0 Ohm. The open-circuit voltage of both coils is 500 mV and the load resistance is kept at 8.62 K Ω . The DC output of Coil A peaks at 8.98 V when the duty cycle is 52%, and the DC output of Coil B peaks at 5.85 V when the duty cycle is 56%, as depicted in Fig. 6. The characterization results indicate that the proposed AC-DC boost converter is able to

produce high DC output with the low-voltage AC input. The electronics modified by the undergraduate research team works well.

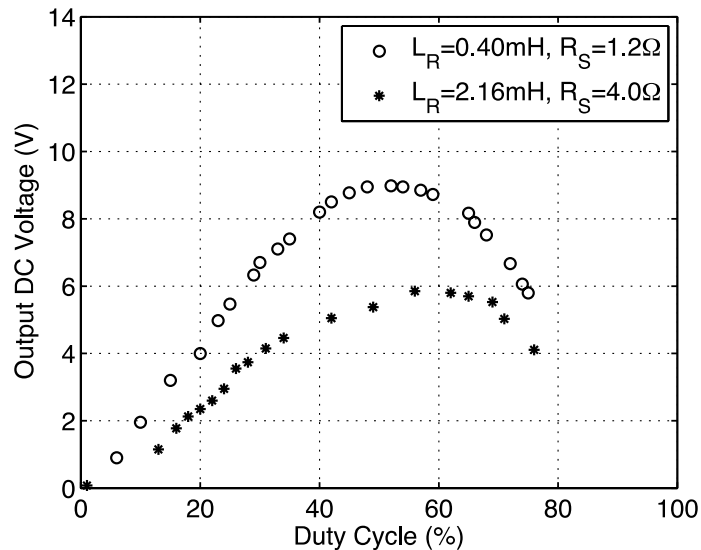

Figure 6: The DC output voltage is measured at various duty cycle of the main switch S_0 's control signal

In the traditional AC-DC boost converter design, the switching frequency is $10 \sim 50 \times$ higher than that of the input AC [12, 13], therefore, the timing between the switching pulse and the input AC is not critical to the converter's performance. In this low switching frequency AC-DC boost converter, the timing between the control signal and the input AC power is important. In the experiment, the DC output voltage across an $8.62 \text{ k}\Omega$ load resistor is measured and plotted in Fig. 7, when a delay time is inserted before the rising edge of the control signal, whereas the falling edge is kept at the 60% of the input AC's half-cycle. In Fig. 7, the delay time T_D is normalized to the control signal period, T_p . The measurement result indicates that the DC output voltage drops less than 10% when the rising edge of the switching pulse is $\sim 20\%$ behind the zero-crossing of the input AC. This measurement suggests that the low-frequency AC-DC boost converter has a large timing tolerance on the comparator, and has the potential to work with high-frequency input AC.

Project Assessment and Future Improvement

Students who participate in the research on the design and optimization of an innovative power harvest device for miniaturized biomedical implant are very enthusiastic about the selected project, and highly motivated to learn electrical engineering. The future improvement suggested by students is to extend the internship into a longer period of time.

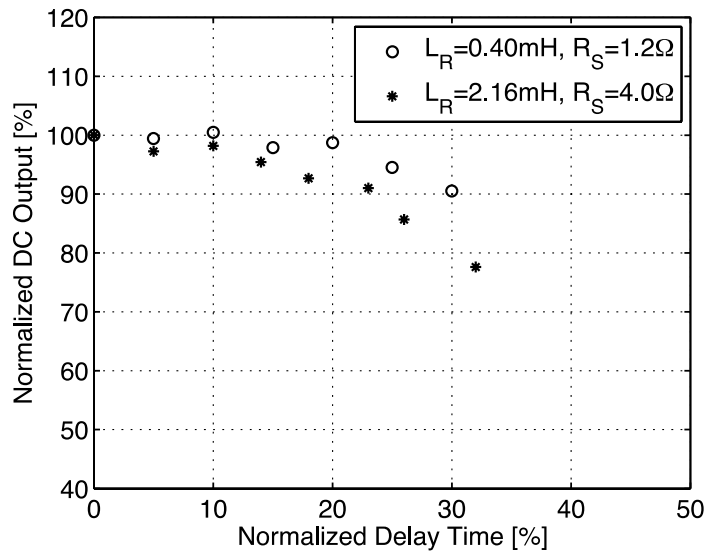

Figure 7: The DC output voltage versus the delay time that is inserted before the rising edge of the pulse.

A survey is conducted after the internship to obtain the assessment of the project. The survey includes four questions that students were asked to rate their level of agreement with each question in a five point scale (1 – Not at all useful; 2 – A little; 3 – Some; 4 – Quite a bit; 5 – A lot), and three questions that students were asked to write their comments. The survey is conducted anonymously so that students are able to express their opinions freely.

Students in the internship program are very enthusiastic about the research, although they just finished engineering preparation courses in the community college and are ready to transfer to a four-year college. Table 1, which extracted from the survey, clearly indicates students’ enthusiasm towards the research.

Table 1: Students’ responses on the results of the internship program

Question: As a result of your participation in the program, how much did you learn about each of the following?

Activity	Average Rating
Performing research	4.69
Designing/performing an experiment	4.85
Creating a work plan	4.77
Working as a part of a team	4.85
Writing a technical report	4.85
Creating a poster presentation	4.62
Making an oral presentation	4.54

When asked the question "what do you like most about the NASA CIPAIR Internship Program?", Electrical Engineering students’ responses are: “*I like the opportunity to conduct research and*

experience how theoretical concepts learned in class can be apply to real world situations. I like the environment created by adviser, mentor, and group mates. We could work and learn as we have some fun”, “It gave us practice with researching a topic.”, and “being able to implement all my knowledge that I have learned in my engineering classes to a research”.

Students who participate the program are very committed in electrical engineering. Students put down comments like: *“I liked how each day I had the chance of learning something new about my major and the principles that goes with Electrical Engineering. Also that the internship was research based.”* and *“I like that we got to work with the EE department and we got to work on a project that interest me.”* These comments show students are interested in electrical engineering.

When asked *“Give at least one suggestion for improvement of the NASA CIPAIR Internship Program?”* The most-likely response is that students want to extend the program to a longer period of time. The suggestions are: *“Increase the number of weeks in the summer projects”;* *“Maybe offer one during a semester. Give more time maybe. like 15-20 weeks.”;* *“The only change that I would consider is if possible is to try to extend the internship longer because 10 weeks is not adequate to comprehend everything.”;* *“Extending the program for a couple more weeks in order to allow the interns more time to understand the material and be able to present a better final report.”.* These comments suggest that students are very interested in research experience.

Summary and Conclusion

The NASA CIPAIR program has successfully integrated the underrepresented minority students from community college into the state-of-art electrical engineering research. With some careful planning, students who participated in the program have indicated that the program has exerted a positive influence in their future STEM learning and practicing.

Acknowledgement

This project is sponsored by NASA Office of Education through the Curriculum Improvement Partnership Award for the Integration of Research (CIPAIR), Grant Number NNX10AU75G.

References

- [1] J. P. Holdren and E. Lander, "Engage to Excel," President's Council of Advisors on Science and Technology, Washington, DC. 2012.
- [2] (2010). *Quickfacts*. Available: <http://quickfacts.census.gov/qfd/states/06000.html>
- [3] M. Gibbons, "Engineering by the Numbers," American Society of Engineering Education 2010.
- [4] B. A. Nagda, S. R. Gregerman, J. Jonides, W. von Hippel, and J. S. Lerner, "Undergraduate student-faculty research partnerships affect student retention," *The Review of Higher Education*, vol. 22, pp. 55-72, 1998.
- [5] W. Ko, S. Liang, and C. Fung, "Design of radio-frequency powered coils for implant instruments," *Medical and Biological Engineering and Computing*, vol. 15, pp. 634-640, 1977.
- [6] Y. K. Ramadass and A. P. Chandrakasan, "An Efficient Piezoelectric Energy Harvesting Interface Circuit Using a Bias-Flip Rectifier and Shared Inductor," *Solid-State Circuits, IEEE Journal of*, vol. 45, pp. 189-204, 2010.
- [7] R. W. Erickson and D. Maksimovic, *Fundamentals of Power Electronics*, 2nd ed.: Springer 2001.
- [8] H. Jiang, J. M. Zhang, S. S. Liou, R. Fechter, S. Hirose, M. Harrison, and S. Roy, "A high-power versatile wireless power transfer for biomedical implants," in *Engineering in Medicine and Biology Society (EMBC), 2010 Annual International Conference of the IEEE*, 2010, pp. 6437-6440.

- [9] SuperMagnetMan. *Super Magnet Man*. Available: <http://www.supermagnetman.net/>
- [10] Faulhaber. *Faulhaber Group*. Available: <http://www.faulhaber.com/>
- [11] L. T. Corp. *LTspiceIV*. Available: <http://www.linear.com/designtools/software/-LTspice>
- [12] H. Jiang, D. Lan, D. Lin, J. Zhang, S. Liou, H. Shahnasser, M. Shen, M. R. Harrison, and S. Roy, "A Feed-Forward Controlled AC-DC Boost Converter for Biomedical Implants," presented at the 34 Annual International Conference of the IEEE Engineering in Medicine and Biology Society EMBC2012, San Diego, 2012.
- [13] R. Dayal, S. Dwari, and L. Parsa, "Design and Implementation of a Direct AC-DC Boost Converter for Low-Voltage Energy Harvesting," *Industrial Electronics, IEEE Transactions on*, vol. 58, pp. 2387-2396, 2011.

Bibliography

1. Dr. Hao Jiang joined San Francisco State University in 2007. Between 2000 and 2007, Dr. Jiang worked as a radio-frequency devices and circuits in Conexant Systems, Jazz Semiconductor and Broadcom Corporation. His recent research in the general area of analog integrated circuits, particularly in ultra-low-power electronics system for biomedical implants. He has served as faculty advisor for the IEEE SFSU chapter since 2008.
2. Dr. Amelito Enriquez has been a tenured professor in the Engineering and Mathematics departments at Cañada College since 1995. He has been an active member of the California Engineering Liaison Council since 1997, and has been serving as the Vice Chair, Community College of the ASEE Pacific Southwest (PSW) section since 2008. He has received awards for his accomplishments related to teaching and enhancing student success. He also received the 2010 NSF Presidential Awards for Excellence in Science, Mathematics, and Engineering Mentoring (PAESMEM).
3. Dr. Wenshen Pong joined the engineering faculty of SFSU in 1998. As a committee chair of over 40 graduate students' culminating experience, Dr. Pong works closely with his students to ensure that they successfully produce and complete quality research work. He was named Faculty of the Year by the engineering societies of the School of Engineering at SFSU in 2000. He also served as Graduate Coordinator from 2001 to 2007. He has been civil engineering program head since 2007 and currently serves as Director of the School of Engineering at SFSU.
4. Dr. Hamid Shahnasser has been teaching and carrying out research at SFSU for the past 22 years. He has received ten NASA related grants and fellowships, and has been working at NASA Ames Research center since 1990. He has advised and mentored many students and successfully introduced some of them to NASA Ames summer internship programs as well as careers at Ames and other NASA sites.
5. Dr. Hamid Mahmoodi is currently an associate professor of electrical and computer engineering in the School of Engineering at San Francisco State University. He was a recipient of the 2008 Semiconductor Research Corporation Inventor Recognition Award, the 2006 IEEE Circuits and Systems Society VLSI Transactions Best Paper Award, 2005 Semiconductor Research Corporation Technical Excellence Award, and the Best Paper Award of the 2004 International Conference on Computer Design. He is a technical program committee member of International Symposium on Low Power Electronics Design and International Symposium on Quality Electronics Design.
6. Cheng Chen joined SFSU in 2009 and he is currently an assistant professor in civil engineering at the School of Engineering at SFSU. He has a strong research background in hybrid simulation and earthquake engineering, and he has published more than twenty technical papers in professional journals and conference proceedings. He has served as faculty advisor for the ASCE SFSU chapter since 2009. He is also a technical committee member of ASCE on structural control and seismic effects.
7. Mr. Ben Lariviere is currently a senior undergraduate student in electrical engineering at SFSU. He has been an undergraduate researcher in the Bioelectronics Lab at SFSU since Nov. 2011.
8. Jose Carrillo, Alam Salguero, Ellaine Talle, Enrique Raygoza, Xenia Leon and Amelito G. Enriquez were student participants of the CIPAIR program from Cañada College. Mr. Carrillo, Mr. Salguero, Mr. Raygoza and Ms. Leon are currently enrolled in electrical engineering in Cal Poly at San Luis Obispo. Ms. Talle is currently a material science student at University of California at Irvine.

Development of International Mobility Program in Micro and Nanotechnology: Lessons Learned

Jesús Acosta-Iriqui, Eniko T. Enikov
The University of Arizona

Abstract

The Advanced International Studies in Mechanics of Micro- and Nano-systems program is a four-year student exchange program under the Atlantis Excellence in Mobility program supported by the United States Department of Education and the European Commission of Higher Education. The main goals of this project was to increase students' academic aspirations in science and engineering careers, increase students' professional aspirations in science and engineering, and increase students' awareness of science and engineering globally. With this presentation, we present some of the experiences that students from two universities in the United States –University of Arizona and University of New Mexico– gained while studying at the two European universities – Budapest University of Technology and Economics and Slovak Technical University – in Hungary and Slovak Republic. In addition, we address some of the challenges that prevented some students from traveling abroad. A successful student recruitment model based on utilization of the Senior Capstone Design course at the University of Arizona was developed and tested. The methods used to evaluate the program were interviews conducted through phone and Skype conference calls with participants. Most interviews were conducted during or after their semester abroad. A total of 23 U.S. students were recruited in a period of 4 years (2008-2012).

Introduction

The Advanced International Studies in Mechanics of Micro- & Nano-systems program was completed in spring of 2012. The program consisted of an engineering student exchange and research arrangement between the University of Arizona, New Mexico State University, Budapest University of Technology and Economics, Hungary, and Slovak University of Technology in Bratislava, Slovak Republic. Like other universities in Europe these two institutions felt well prepared to receive international students, in this case from the U.S. [1] A total of 23 students were recruited in a 4 years period –from 2008 to 2012. The main goals of the program were to increase students' academic aspirations in science and engineering careers, to increase students' professional aspirations in science and engineering, and to increase students' awareness of science and engineering globally. The third goal somehow addresses what has been recently reported, that the U.S. must commit to embracing global economy and awareness, and train its workforce to be more competitive globally.[2] This paper documents the extent to which

these goals were met through a review of interviews (conducted through Skype conference calls or telephone) with participants. Overall, the program appeared to have made important inroads to meeting these goals. The program was well-run and met students' needs having a positive impact on them. An average of 6 students were recruited every year, however one of the students from NMSU participated in the program two semesters.

The program was supported by the U.S. Department of Education's Fund for the Improvement of Post-Secondary Education and the European Commission's Atlantis Program, this project was intended to support bilateral study abroad exchanges for up-to six students per over a period of four academic years. The goal of the program was to recruit three students from UA and three from NMSU to spend a semester at one of the European partner universities. Each student received a \$5,000 stipend to cover travel and living expenses. Such program supports the importance of global education, recognized by the National Science Foundation (NSF), which has developed several programs focusing on global placements. This program addresses the importance of supporting U.S. scientists and engineers in developing international collaboration adding to their experiences early in their careers. [3] Like NSF, the National Academy of Engineering stresses the global perspective of awareness as result of international exchange programs. [4]. In addition, The National Science board has stated that a key challenge in engineering is how the U.S. programs react to the changing global context of science, technology, and engineering. [5]

The exposure of students to global perspectives implies to "work effectively with people who define problems differently." [6] Students who participated in the exchange program were expected to take at least one course at their host institution; however, they were encouraged to enroll in two or more courses during their semester abroad. Students who participated in the program were also expected to participate in a faculty-directed research project directed at their host institution. It was anticipated that students would acquire new knowledge through formal instruction as well as technical and professional skills through collaborative research projects in which they got involved. Overall objectives of the project include increasing students' knowledge of global opportunities in science, engineering and technology and heightening students' commitment to science and engineering careers and further education. This paper addresses only the United States part of the program.

Methods:

The research questions addressed the extent to which the Advanced International Studies in Mechanics of Micro- & Nano-systems objectives were met over the four years period of the project. These questions were:

- How has the experience of studying abroad impacted students' science and engineering academic aspirations and commitment?
- To what extent has studying abroad influenced students' science and engineering career goals?

- How has studying abroad contributed to students' awareness of the global relevance of science and engineering?

Additionally, the overall programmatic performance with special attention given to improvements made was addressed.

Qualitative research methods were employed to evaluate its results. These methods were selected for three interrelated reasons. First, the number of students who participated in the program was limited; it would not be possible to conduct robust statistical analysis with survey or other quantifiable measures. Second, qualitative methods are best suited to gather "thick" accounts of individual experiences. And third, in-depth interviews are appropriate for gathering data necessary to answer the evaluation questions, which focus on individual understanding and goals.

A total of Twenty-three students were recruited, twelve from UA and eleven from UNM). They were in their second or third year towards graduation and their ages varied from 20 to 25 years old. A total of six women were recruited, 5 from UA and 1 from UNM. All students were American, 83% Caucasian and the other 17% of the students were of Mexican background.

Data were gathered through semi-structured interviews. A total of twenty-eight interviews were conducted. Some participants were interviewed before they departed for their semester abroad, other were interviewed while their time abroad, and the rest after they returned. Three students who knew about the program but chose not to participate were also interviewed. These baseline interviews were intended to understand students' academic commitment, career goals, and knowledge of science and engineering globally. Additionally, these interviews were used to gauge the reasons why students choose either to accept or forgo the opportunity to participate in the program. Interviews also were intended to understand how the experience of studying abroad had affected students' aspirations and understanding of science and engineering globally were affected by their experience abroad. All interviews followed the same protocol (see Appendix) and lasted from 30 minutes to one hour. Interviews were conducted in person, over the telephone, or through Skype internet video conference. All interviews were audio-recorded then transcribed, reviewed and analyzed for emerging themes under grounded theory analysis [7].

In addition to interviews, supplementary data were gathered through content analysis of student study abroad blogs and in-person and e-mail contact with the project's principle investigators. Information from these sources was used to develop a deeper overall understanding of the program and to triangulate interview findings.

Interviews capture rich accounts of individuals' experiences that can be used to make overall assessments of the program. However, as with all qualitative research, the findings from this evaluation are not generalizable to a population. These limitations are furthered by an incomplete

follow-up set of interviews. Nevertheless, given the consistency between interviews within each year and over the four years, evaluation data have achieved satisfactory levels of trustworthiness.

Findings:

The findings are organized in four different themes. The first three address each of the main research questions. The final section reports on the overall performance of the program and outlines where the program improved or not during the four-year period.

Academic aspirations and commitments

All students had clear academic goals and all were committed to their education. The primary objective for most participants was to complete a baccalaureate degree in engineering; several students indicated interest in graduate education; all of the students who indicated and interested in graduate school wish remain in STEM fields; and most students indicated that labor-market demands would determine their level of educational attainment (they will pursue education to the level required for their desired professional position).

Except for one student out of four interviewed in the third year cohort who originally did not think or had in mind attending graduate school, the rest addressed that graduate school has become a priority once they finish or obtained their baccalaureate degree. Students in the third- and second-year cohort tended to have higher educational aspirations than those in the first and the fourth year group. Three of the six students in the second year indicated a strong interest in graduate school immediately following their undergraduate education and the other three indicated that graduate school is an option they are considering. One student, the only senior that participated, had applied to several graduate programs and for graduate fellowship funding by the time of the follow-up interview. There are several other reasons that may explain the difference. The increased aspirations of the year two and three cohorts may have to do with increased educational intentions during a tight labor market, with more students considering graduate school when jobs are scarce. It may also be related to more educationally ambitious students participating in the program after observing successful experiences among their peers who participated in the first year. Finally, the most likely reason for the increased aspirations among the third and second year cohorts is that students were recruited to combine their study abroad experiences with a capstone research project. This capstone resulted in a 90 page research report written by four of the exchange participants summarizing their research on an automated fish tracking system using MATLAB.

It is important to mention that two of the five students of the three-year cohort expressed that, their decision for participating in the exchange program was done once they consulted with their advisors and/or professors in their programs if their participation would have an impact on the time for obtaining their current undergraduate studies. This was the case of one student on year-four. One of the two students, who decided not to participate in the exchange program on year-three, expressed that her decision was made thinking that she would be held back a year in her program. She also added that if this program were more of a 'track' where students could chose to take the study-abroad track as a replacement of the senior year, more students would choose to participate.

The stated academic aspirations of students who participated in the exchange program largely remained unchanged. All of the students maintained their educational aspirations and their interest in research increased. However, maintenance of aspirations is not an indicator that the exchange program is ineffective in stimulating educational aspirations. Most of the students reported enjoying the research aspect of their time aboard and having developed a stronger interest in research. Interviews with third and second year participants show that the experience abroad consolidated their educational aspirations and while their academic goals may not have changed they now appear to be firmer.

Many students who participated in the program had already engaged in educationally rich activities such as previous study abroad experiences, engaged in research, and/or worked as unpaid interns. Student self-selection may account for both predication and educational aspirations, and the exchange program may be a component of a set of opportunities that help to shape and depend students' academic commitment to STEM fields.

While the Advanced International Studies in Mechanics of Micro- and Nano-systems program was clearly serving the ambitions of students well, there was room for expanded participation. Students who had not participated in educationally enriching activities such as internships and study abroad realized enhanced benefits from participation.

For all students, engineering education pedagogy in Hungary and Slovakia differs from what is typical in the United States. Varying pedagogues expand and challenge students' learning modalities. The two mayor differences expressed are individual focused instruction and assessment style encourages students to become more pro-active and accountable for their own learning, and inform experiences of living and traveling in a foreign country reinforce students' self-efficacy.

Students from third cohort had similar experiences to the first one; they did not experienced cultural and logistical difficulties as students in the second-year cohort described. These differences are almost certainty the result of varying individual experiences and perceptions rather than actual differences in the program. Moreover, the difficulties described by returning students did not adversely affect their overall experiences in any meaningful way.

Career goals and aspirations

Hundred percent of students indicated plans to work in engineering. Some students had a clear industry or sub-field goals while others expressed familiarity with mechanical engineering jobs.

Four of the four interviewed students in the third and fourth year cohorts expressed specific areas of engineering they would like to continue working on, compared to students participating in year one cohort who did not have clear goals. Year two students like students in cohorts three and four were, overall, more knowledgeable about careers and expressed more specific interest in particular jobs. This is not surprising given that these groups also had more specific academic aspirations.

Compared to students in cohort year-one and two, students in cohort three and four expressed that their experiences abroad have had impacted and strengthen their career aspirations. Some students develop more specific and stronger career goals, while others did not.

One of the students of the third cohort, interviewed while still been abroad expressed strong interest in continuing a research path in addition to seeing himself as a business man, promoting his own invented products having a positive impact in society. Both of the students who were interviewed following their experiences abroad in the first year of the program identified sub-fields of particular interest, a plan for learning more about specific opportunities in these fields, and a list of potential employers. However, this was much less career aspiration growth among year two participants. It should be stressed that this difference is not surprising given that year two participants entered the program with greater career focus.

After the first year, it was speculated that potential career aspiration growth would be developed through participation in the program due to two factors: 1) increased exposure to research; 2) the maturation and self-exploration that often occurs during study abroad experiences. Regardless of whether or not changes in career aspirations are immediately evident, it is likely that all participants in the program benefit from both of these factors.

Understanding global opportunities in science and engineering

Participants expressed a strong understanding of science and engineering abroad. Most students described some similarities and differences between the U.S. and European scientific enterprises, they also understood that the U.S. position in science and engineering, while strong, is not as advanced relative to economic competitors as it once was.

There were remarkable similarities in understanding and sensitivity about the state of science and engineering internationally. Participants appear to develop a deeper understanding of science and engineering around the world and especially in Europe.

In-class and research experience provides a vehicle for understanding the level of development in European engineering as well as the specific problems that are of most interest in Hungary and Slovakia; Social interactions with local students as well as students from other European countries and around the world are important in expanding students' knowledge of science and engineering abroad; students also developed a greater appreciation for the standard of facilities in the U.S. in comparison to universities in Hungary and Slovakia.

According to three students in cohorts year-three and -four there is a specific area of engineering that leads in European countries compared to the U.S. (in the context of Arizona and New Mexico) being this urban transportation; however, the other students were limited on expressing specific areas of engineering in Hungary and Slovakia beyond what they see or hear in the university they attended for the exchange program. The experiences of students who participated in year one and those who participated in year two are very similar in this regard. One student was especially notable. After spending a semester at STUBA decided that she wanted to pursue a PhD in Germany.

Overall programmatic assessment

The Advanced International Studies in Mechanics of Micro- & Nano-systems did a great job over the 4 years the 2008-2012. At least one student participated in both academic semesters. Students that participated after year one and two reported that the program was more visible than in previous years and anticipated that many of their peers would be interested in participating in future semesters. Despite recruitment efforts for year three of the program, fewer students participated compared to years one and two, however more students participated in year 4 which balanced and meet the recruitment goals for the length of the program.

The first and second year evaluations made a few recommendations, each of which was addressed during the third and fourth year. The following identifies the first two years recommendations and describe steps that have been made to meet these recommendations.

A wider recruitment effort should be made. During the first year of the program students indicated that they believed the existence of the program was not widely known among students. Students interviewed during the consecutive years indicated that the program was well advertised and that the experiences of past participants were well known by engineering students at UA and NMSU. Moreover, students indicated they felt they had enough information about the program.

Women students should be recruited to participate. No women students participated in the first year of the program; a trend, which is not uncommon in engineering fields. However, one woman student participated in the second year of the program and one cancelled her participation in year three. Several women students participated in the program during its four year. Students indicate that special outreach efforts were made through women in engineering groups. Expanding the participation of women in the program was major accomplishment.

Students should be asked to perform some summative activity to reinforce their learning. While the experience of participating in the program was clearly beneficial for the students, they were not asked to reflect upon their experiences to help formalize what they learned. During the second and third year, returning students were asked to give presentations to peers and prospective participants. This activity served two purposes. First, it helped participants to consolidate and articulate their learning. Second, it was a powerful recruitment tool for future participants.

Several participants after year one also participated in a capstone research project. This project resulted in an extensive report and the students from different cohorts continued to maintain a web-site reporting on both their research findings as well as content about their experiences abroad. This was also a powerful summative tool that both helps to consolidate learning and increases the programs' exposure, as well as an additional recruitment tool.

Recommendations and conclusions:

The Advanced International Studies in Mechanics of Micro- & Nano-systems appeared to be a well-run program, making important strides towards meeting its goals of increasing students' academic and professional aspirations and raising awareness about science and engineering

globally. The challenge for each year of the program was to build upon the headway made during the previous year. Efforts to recruit women and develop summative activities for students to consolidate their learning continued.

While the total number of recruited participants during year one and two was excellent, student recruitment for year three and four was expanded in two ways. First, efforts were made to attract students to participate in the program during both academic semesters. Having a balance in semester participation kept interest in the program active among potential participants. Second, efforts recruiting students with limited or no previous international experience were made because these students stand to gain the most from participation. It was acknowledged, however, that this final recruitment recommendation was difficult. The program directors did not know which students had extensive experience abroad and which students did not. Moreover, students with limited international experience could not wish to participate in the program. It was anticipated after the first year, given the success of this first year, that the Advanced International Studies in Mechanics of Micro- & Nano-systems would further improve over the next three years. The program met its goals and continued to improve.

Acknowledgements

This bi-lateral student exchange program was supported by grant #P116J080016 from US Department of Education Fund for the Improvement of Postsecondary Education (FIPSE).

Bibliography

1. Andersen, A. "Implementation of engineering product design using international student teamwork – to comply with future needs", *European Journal of Engineering Education*, 2001, Vol. 26, No. 2, pp.179-186.
2. National Academy of Engineering, *Engineer of 2020: Visions of Engineering in the New Century*, National Academy Press, Washington, DC., 2004.
3. Office of International Science and Engineering, National Science Foundation, Accessed at: <http://www.nsf.gov/div/index.jsp?div=OISE>
4. National Academies of Science Engineering and Medicine, *Rising Above the Gathering Storm*, National Academy Press, Washington, DC, 2007.
5. National Science Board, "Moving Forward to Improve Engineering Education", National Science Foundation, Arlington, VA, November 2006.
6. G.E. Downey, J.C., Lucena, B.M. Moskal, R. Parkhurst, T. Bigley, C. Hays, B.K. Jesiek, L. Kelly, J. Miller, S. Ruff, J.L. Lehr, A. Nichols-Belo, "The Globally Competent Engineer: Working Effectively with People who Define Problems Differently", *Journal of Engineering Ed.* Vol. 95, No. 2, pp.107-122.
7. B. Glaser, A. Strauss, *The discovery of grounded theory: strategies for qualitative research* – Chicago, IL: Aldine, 1967.

Work-In-Progress: Enhancing Students' Learning in Introductory Power Electronic Course Using an LED Driver Project

**Taufik, Dale Dolan
California Polytechnic State University, San Luis Obispo**

Abstract

This paper presents a new hardware project assignment introduced in the first course of power electronics at Cal Poly State University, San Luis Obispo. The new project is a culmination of series of experiments in the laboratory portion of the course. There are several objectives for assigning the project. First, the project is aimed to enhance students' learning by exposing students to practical issues in dc-dc converter designs. Secondly, the project will sharpen students' practical skills required by industry which are often not being taught to students as part of the curriculum. This, in turn, will help students in pursuing their career in the power electronics industry due to the skills learned from the project which match current demands from the power electronics industry. The project will also enforce students to learn beyond circuit design by incorporating one modern and widely used power electronic application as the final deliverable of the project. Consideration was taken such that the complexity of the project should be appropriate for an undergraduate level course. Detailed description of the project along with preliminary results of student's assessment on the project will be presented in this paper. Challenges of conducting the project both for the instructor and students will also be discussed.

Introduction

In many aspects of our daily lives, we often use appliances, tools, electronics which require conversion from one form of electrical energy to another. For example, many of the appliances we use in our house and office requires an ac input power which typically comes from the utility through the wall-plug. This ac power then goes through the process called rectification where it is being converted into dc power to operate many dc components inside appliances. Portable electronics is another good example where electrical energy conversion takes place in the form of dc power level obtained from one or multiple batteries to several dc power levels supplying the proper power the many chips inside the electronics. In the electrical engineering field, Power Electronics is an engineering discipline that deals with these types of conversion. More specifically, power electronics is enabling technology allowing us to convert energy from ac to dc, ac to ac, dc to dc, and dc to ac. Power electronics has become increasingly important nowadays where billions of kilo-watts of electric power are being re-processed every day to provide the appropriate type and level of power needed by loads¹. Due to the rapid growth in power electronics technology, there has been an increasing demand from industry for electrical engineers that possess power electronic background. This has been reflected mainly by the number of power electronics companies who have participated in on-campus career fair at Cal Poly and who have recruited electrical engineering (EE) students with specifically power

electronics background. Such demand in turns spurred significant growth of interest among EE students at Cal Poly in power electronics as indicated by the steady increase in the number of students enrolled in power electronic courses².

At Cal Poly San Luis Obispo, we currently offer technical elective courses related to power electronics. These courses are mainly geared for our EE students, although they are also open to any non-electrical engineering majors. The following is the list of these courses along with their descriptions³:

EE 410 Power Electronics I

Introduction to power electronics and power semiconductor devices. Analysis, performance characterization, and design of power electronics converters such as: rectifiers, DC choppers, AC voltage controllers, and single-phase inverters. Operation of DC motor drives. Use of commercially available software. 3 lectures, 1 laboratory.

EE 411 Power Electronics II

Switching losses. Analysis, performance characterization, and design of snubber circuits and resonant converters. Operation of DC transmission lines, flexible AC transmission system (FACTS) controllers, three-phase inverters, and AC motor drives. Use of commercially available software. 3 lectures, 1 laboratory.

EE 420 Sustainable Electric Energy Conversion

Electrical engineering aspects of photovoltaic and wind power generation and usage, and electrochemical energy conversion. Power control, processing, and quality for grid-connected and stand-alone systems. Distribution and storage of electric energy. Hydrogen and synthetic fuels. Distributed generation. 3 lectures, 1 laboratory.

EE 433 Introduction to Magnetic Design

Design of magnetic components. Fundamentals of magnetics, magnetic cores, design of power transformer, three-phase transformer, dc inductor, ac inductors, dc-dc converter transformer design, actuators. Use of commercially available software. 3 lectures, 1 laboratory.

EE 520 Solar-Photovoltaic Systems Design

Solar radiation and insolation variability. Solar cell theory. Photovoltaic module and array design. Interfacing PV generators with various kinds of loads. Power processing circuits and systems. Energy storage options. Stand-alone and grid-connected systems. Economic and policy issues. 4 seminars.

EE 527 Advanced Topics in Power Electronics

Selected advanced topics in power electronics such as dc-dc converters, phase-controlled rectifiers, switched-mode inverters, ac and dc drives, HVDC transmission, or utility applications of power electronics.

As stated in the above course descriptions, four out of the six courses have lab portions where students conduct hands-on experiments in power electronics and its related applications. This is in line with Cal Poly's "learn-by-doing" philosophy. The last two courses (EE 520 and EE 527)

are actually graduate-level courses, and although they don't have lab portion of the courses, practical hardware projects are assigned in these courses.

To better prepare our EE students and to better align with industry needs, the above courses have undergone revamping of their contents. In addition, new lab experiments involving both concepts and modern applications have also been implemented in the lab portion of the courses. Equally important is the newly developed hardware project in each course to improve students' learning by exposing them to real-world circuit design and applications. In addition, these hardware projects were designed with increasing level of difficulty as students progress through the sequence. This paper focuses on the recently developed hardware project for the introductory course in power electronics EE 410. The hardware project emphasizes on practical skills in power electronics while familiarizing students to one widely used application of power electronics.

Hardware Project Background

Since Fall 2006, a final hardware project has been a requirement in the introductory power electronic course EE 410. This first hardware project was brought about following feedback from companies who recruit from Cal Poly and identified certain practical skills needed to start as new engineers in these companies such as board layout, real world component selections, soldering skills, surface mount components, magnetic design/calculations, and performance testing of dc-dc converter⁴. These practical skills despite their importance are rarely covered in traditional power electronic courses for undergraduates due mainly to time constraint. Therefore at Cal Poly San Luis Obispo, these topics were addressed mainly in the final hardware project assignment. For EE 410, the hardware project involved the construction of a boost converter and was mostly supported by Linear Technology.

While the response by students and companies are positive⁴, the boost converter project lacks practical application which further enforces students' understanding of how the boost converter may be useful. Therefore starting Fall 2012, a new hardware project has been assigned which still revolves around boost converter.

The Hardware Project

The new hardware project for the EE 410 course requires students to construct a boost converter for an LED driver. The controller used for the boost LED driver has the ability to adjust the dimming level of the LEDs. Therefore, the project not only addresses the same issues as the previous one it replaces, but it also offers students a great example of how the circuit may be applied in real world and method to achieve it. In addition, the inclusion of white LED lights as the output of the project will make the project more interesting due to the visible results that students will see instead of merely looking at voltages and currents. The new hardware project was fully supported by Linear Technology who supplied all components required to build a complete LED driver circuit. A group of 2 to 3 people is required to perform the project which is worth 15% of the overall grade. During the 10th week of the quarter, each group has to demo their hardware project and is being graded based on criteria as presented.

Objective:

Build the following LED Driver using LT1618 switching regulator from Linear Technology.

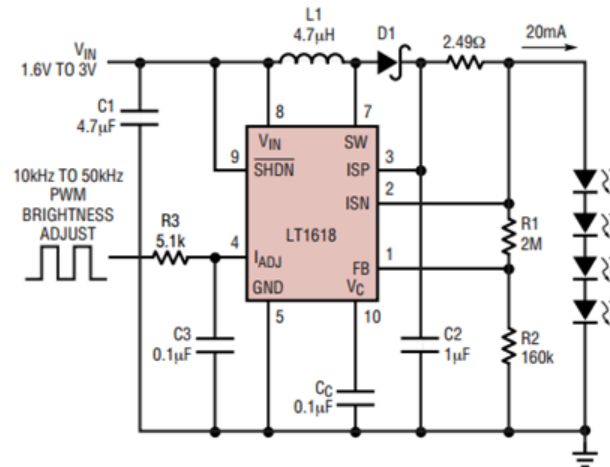
Components:

Linear Technology will provide most of the required components which include the main components such as the LT1618 chip, inductor, and diode.

The converter must meet the following specifications:

1. Output is driving White LEDs
2. Constructed on the provided test board
3. Nominal Input Voltage = 2.5 V
4. Maximum Output Current = 20 mA
5. Efficiency at 20 mA \geq 80%

Deliverables:

- LTSpice simulation results showing all specifications are met
- A fully operational LED driver

The grade for this project will be based on:

- How well the driver meets specifications (both simulation and hardware)
- Neatness/aesthetic of the driver circuit (wiring, component placements, layouts)

Hardware demo must be performed during the dead week with the last day to demo is **Friday, Nov 30, 2012 before 5pm**. A sign-up sheet will be posted on my office door the week before the demo week on a first-come first-served basis.

Early demo is encouraged and will be scheduled only by appointment.

Results and Initial Assessment

Figure 1 depicts the finished circuit board layout which shows the challenge that students have to face in terms of dealing with very small surface mount components. Figure 2 also shows a finished hardware project with LED lights turning on.

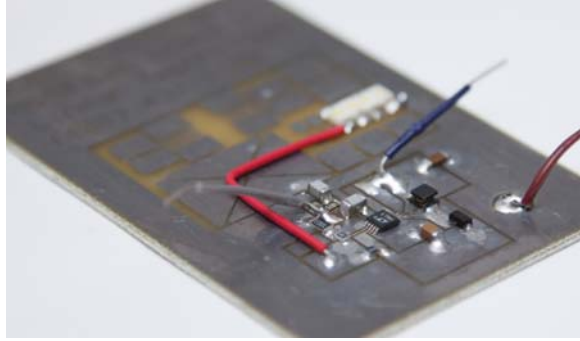

Figure 1. Circuit board layout of a finished project



Figure 2. Top view of a finished project with LEDs turning on

Preliminary assessment using survey was developed and data were collected as shown in Table I. The survey questions are exactly the same as those given for the previous hardware project⁴. As many as thirty-five students participated in the simple yes/no survey given in Fall 2012.

Table I. Survey questions from Fall 2012

Survey Questions	Yes	No
Before this project, have you worked on surface mount components (selecting, buying, or soldering)?	23.2%	76.8%
Before this project, were you aware of surface mount inductor?	53.6%	46.4%
Before this project, were you aware of surface mount power electronic components?	80.4%	19.6%
Has the project increased your awareness of surface mount power electronic components?	68.0%	32.0%
Has the project increased your skill in working with surface mount components?	76.8%	23.3%
Has the project helped you in learning dc-dc converter in general?	91.0%	9.0%
Has the project helped you in learning dc-dc converter performance testing such as line and load regulations, efficiency, peak to peak output voltage ripple?	94.6%	5.4%

As shown in Table I, most students felt that the new project did help them in understanding basic operations and performance testing of dc-dc converter which is central to the course. The majority of students also believed that the project successfully enforces them not only their awareness of surface mount components, but also on how to work with the small surface mount components. Overall, the results of the survey show how the new project has indeed increased technical and practical skills in power electronics among students.

Conclusion and Further Work

In this paper, a new hardware project that incorporates real-world practical application while enforces practical skills has been presented. The new project was developed for students taking the introductory course in power electronics at Cal Poly San Luis Obispo. The project was assigned for the first time in Fall 2012. Difficulties encountered by students were observed to include getting familiar with soldering and handling surface mount components which may be time consuming and frustrating. Learning how to layout extra small components also turned out to be a challenging task for students. From the instructor's point of view, assigning such a project requires significant amount of time to help troubleshoot problems as well as for hardware demonstration of the project. More data still needs to be gathered to assess the effectiveness of the project and whether learning objectives related to practical skills are being met by completing the project. Feedbacks from companies should also be sought to verify whether students going into their new engineering program are prepared better when performing their work.

Acknowledgment

The author wish to thank Linear Technology for providing the full support on the boost LED driver project.

Bibliography

1. P. Thollot, "Power Electronics Today", Proceedings of the 1990 IEEE Colloquium in South America, 1990, Pages 184-187.
2. Taufik, "Power Electronics Courses That Work", Proceedings of 2006 Frontier in Education Conference, San Diego, Oct 2006.
3. Cal Poly website, http://www.catalog.calpoly.edu/2011cat/cenr/ee_dept/eecrs2011.pdf, retrieved February, 2013.
4. Taufik, "Work in Progress: Improving Learning Using Industry Supported Project in Power Electronics Course", Proceedings of Frontiers in Education Conference, October 2007.

Easy Tracking System: a Valuable Outcome of a Student Capstone Project

**Mohammed Alani, Alaa Ayoob, Jino Raj Xavier, Sameeullah Sharief,
Mohammad Amin, Marcos Turquetti and Pradip Peter Dey
National University, San Diego, California**

Abstract

Easy Tracking is a unique and an innovative tracking system that uses Bluetooth, Short Message Service (SMS), Global Position System (GPS), and Google Map technologies to develop a new mobile application. This system helps to keep monitoring of someone's personal belongings or loved ones (children or pet). The application utilizes the Java programming language and Android platform. It can be installed on any mobile device including smart phone, laptop, iPad, etc. This system is appropriate for tracking missing luggage, car, child, and pet in a cost effective manner. It can also be applied to monitor elderly patients in a nursing home and children in a daycare. In this project, a prototype was developed and tested for validating the proof of concepts by using two Bluetooth enabled mobile devices. The prototype was able to monitor a child's movement within 10 meters from the parents. Bluetooth technology was used to establish a short range wireless communication channel between two mobile devices. In this case, two smart phones were used (one for the parent and one for a child). The GPS technology was used for determining the exact locations and distance between these phones in real time and SMS technology was used for delivering this valuable information. The prototype was demonstrated and project findings were presented to a Faculty Judging Panel of three external and two internal judges. The overall quality of the project was found to be satisfactory and rated high.

Key Words: Android, Bluetooth, GPS, Mobile App, Smart Phone, and SMS.

Introduction

In this advanced technological era, wireless communication is one of the fastest growing technologies which is being applied to almost all areas of our daily life. Wireless systems are most commonly used at the present time since these systems are widely distinguished in its varieties in the form of handsets and internet distributors. So, these are easy to use and cost effective. Basically, this project of Easy Tracking system is based on the use of wireless technologies (Bluetooth and GPS) incorporating Java programming in the Android environment. The benefits of this wireless system are many such as cost effective, user friendly, accurate measurement, and fast communication compared to other tracking systems. This proposed system will help keep track of children within a limited area from their parents avoiding a traditional leash which is commonly seen in many busy airports, shopping malls, stadiums, parks, etc. A typical diagram of commonly used system (using a leash) is shown in the Figure-1a and a block of the proposed system using wireless technologies is shown in the Figure-1b.



Figure-1a: Mother controls a child with a leash



Figure-1b: Easy Tracking Interconnection

In this project, short range Bluetooth radio channels and GPS technologies were used to connect two smart phones for tracking their locations within a limited range (see Figure-1b). The functions and operational procedures of Bluetooth and GPS are described in the literatures¹⁻⁷. A Bluetooth and GPS enabled Android phone is used as the main unit called ‘parent phone’ which is programmed with a software application (Android app). The parent phone stays connected with the sensor unit, called ‘child phone’, to keep tracking the child phone’s location continuously by using SMS.

The proposed system utilized the Bluetooth technology to maintain the concavity between two phones to stay in a short range (less than 10 m). A software application based on Java programming was developed and installed on the parent phone to check the connectivity and position of the child phone regularly. GPS technology was used in this project to check the exact position of the child phone. Once the child phone goes out of range (more than 10 m) then connectivity of this system gets terminated and initiates an alarm in the parent phone in the form of vibration and ringing. This way parents can start looking for their missing child immediately in an efficient way. There are many other tracking systems available in the current market, but this proposed Easy Tracking system has some extra merits. Table-1

exhibits a comprehensive comparison of other existing systems similar to the proposed Easy Tracking system.

Table-1. Comparison of Other Similar Products

Features	EasyTracking App	Toddler Tag Child Locator	Spy Mini GPS tracking Device	LOC8TOR Lite	GT30	ST-2011
Tracking Using GPS	Yes	Yes	Yes	No	Yes	Yes
Tracking Using GSM	No	No	Yes	Yes	Yes	Yes
Tracking Using Bluetooth	Yes	No	No	No	No	No
Tracking Accuracy To Target's Location	10 Meters	8 Meters	5 Meters	5 Meters	6 Meters	5 Meters
Battery Life	6-12 Hours	6 Months	6 Months	6 Months	55 Hours	48 Hours
Price	Less than \$15	\$44.90	\$54.58	\$73.90	\$106.66	\$149.35

Methodology

In order to implement this proposed Easy Tracking system, it was needed to integrate both hardware and software. Following is the list of hardware and software requirements:

- i) Hardware requirements: Two Android smart phones equipped with Bluetooth, GPS, and SMS.
- ii) Software requirements: Java programming, Eclipse editor, Android Operating system.

The goal of this project was to design and develop a tracking system using wireless technologies in order to monitor a child's movement in a busy area. This was being done by establishing a short-range wireless link between the parent and the child by pairing of two Android phones. Figure-2 shows the block diagram of this proposed system.

In this project, a set of new Mobile Apps was developed using J2E java codes. Interfacing was developed by using XML codes, Bluetooth connectivity and alarm applications were developed using Java codes and the GPS location program was also developed using Java⁹⁻¹³.

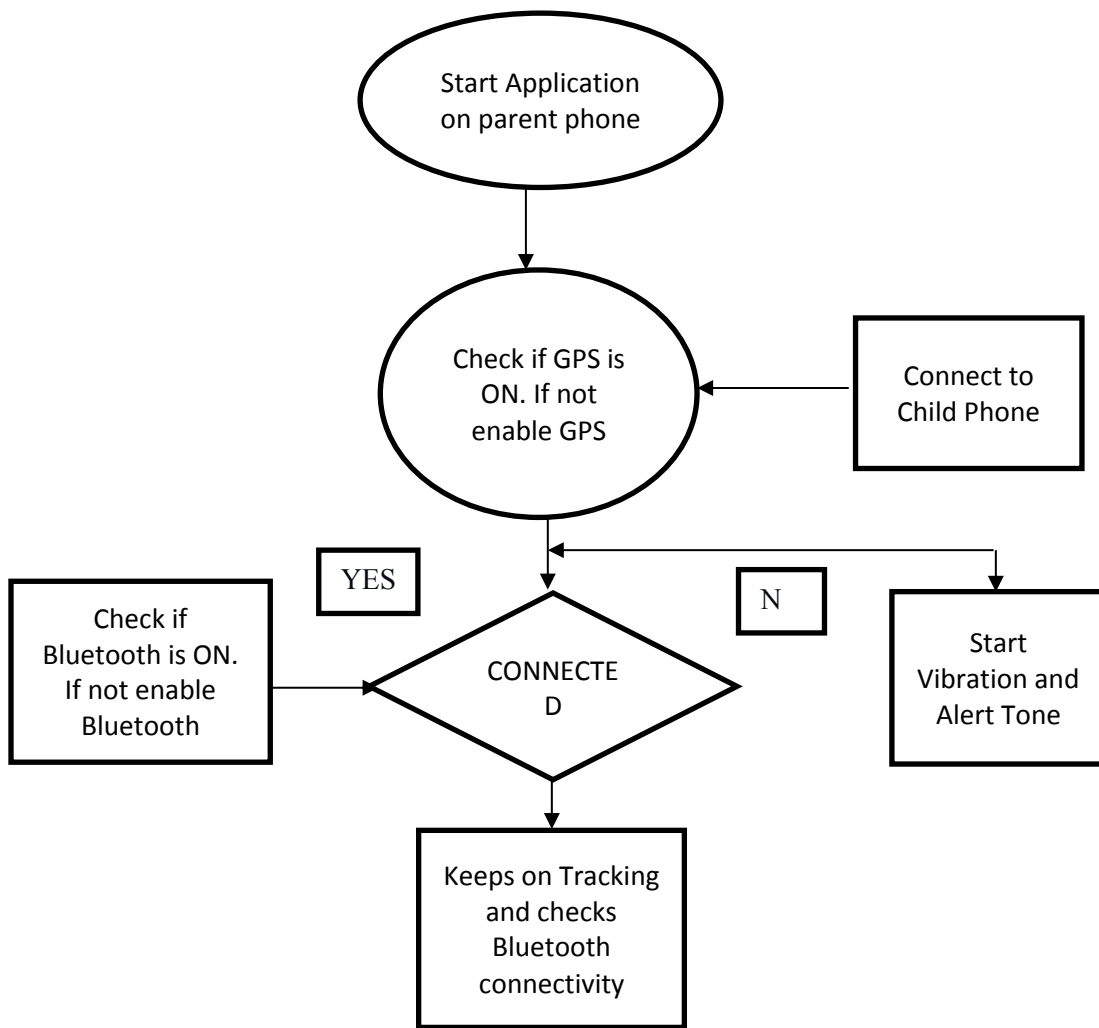

Figure-2: Block Diagram of Easy Tracking System.

Validation of Easy Tracking System

In this project, an additional thorough investigation was conducted using a software (inSSIDer) to test and evaluate the performance of this newly designed and developed tracking system both indoor and outdoor. The distance at which the Bluetooth pairing is disconnected is taken as a parameter in this study. The pairing distance was measured under different RF conditions from different angles. Some quiet and noisy locations were selected for this investigation. Table-2 shows some of these selected locations in San Diego, California and the measured Bluetooth connectivity distances.

Table-2: Selected Locations and the Measured Bluetooth Connectivity Distances

DIFFERENT LOCATIONS	WITHOUT OBSTACLES	WITH OBSTACLES
QUALCOMM STADIUM	9 M	8.9M
DOWN TOWN SAN DIEGO	8.7M	8.55M
NATIONAL UNIVERSITY INDOOR	8.8M	8.7M
NATIONAL UNIVERSITY OUTDOOR	8.9M	8.85M
MISSION VALLEY MALL	8.7M	8.6M

Figure-3 shows a graph that illustrates the distances, locations, and barriers between the parent phone and the child phone. Parent phone is located at the center of the circle and the child's phone can be anywhere in the graph. Once the child phone goes out of this circle then the parent's phone will start vibrate and display the distance and direction of the child phone's location.

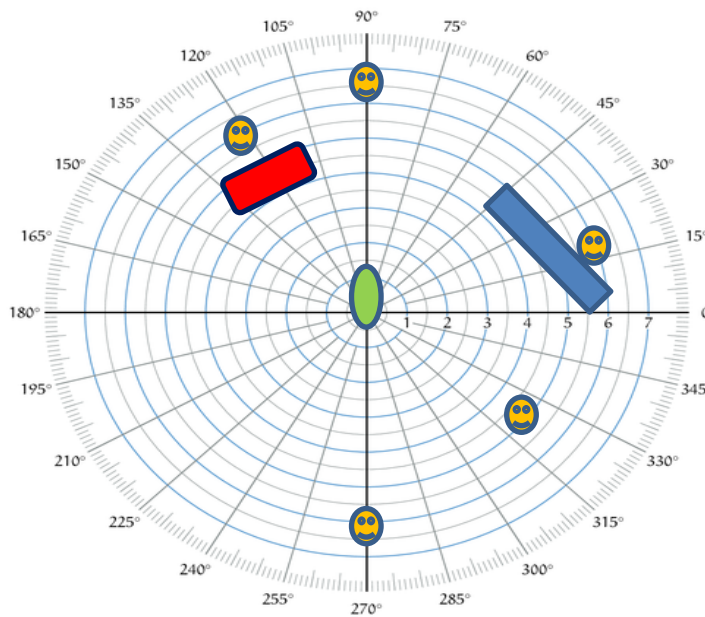
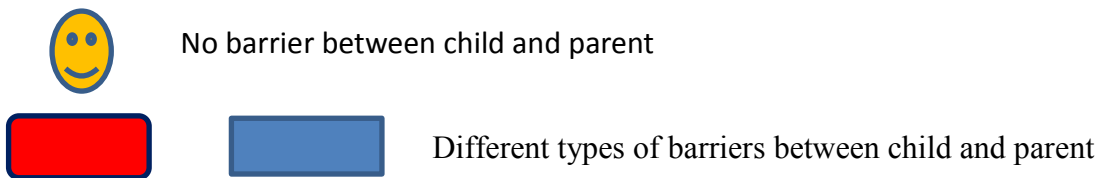
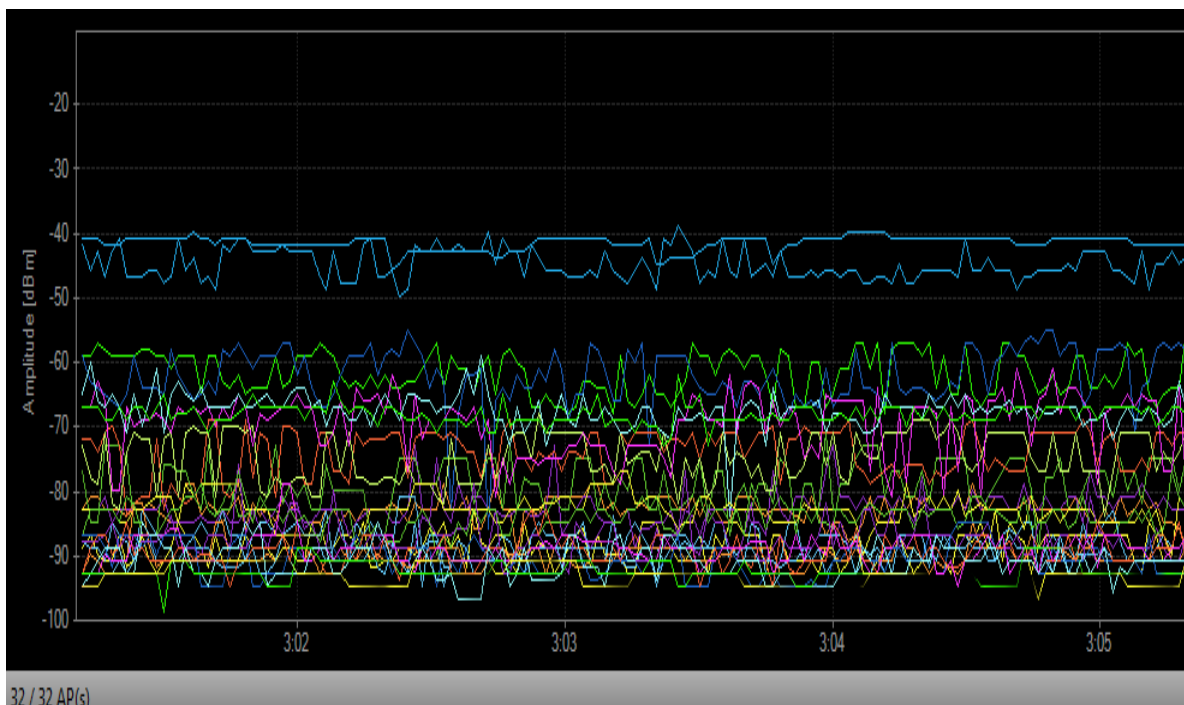

Figure-3: Locations, Distances and Obstacles between Two Phones

inSSIDer

inSSIDer is a Wi-Fi network scanner software⁸. This software was used to check and evaluate various RF conditions under which this experiment was conducted. The inSSIDer is capable of:

- ⊙ Working with the internal Wi-Fi radio system
- ⊙ Collecting DWi-Fi network information (e.g. SSID, MAC, access point vendor, data rate, signal strength, and security)
- ⊙ Determining the graph signal strength over time
- ⊙ Showing how Wi-Fi networks overlap.
- ⊙ Comparing graphs between the signal strength and time domain.
- ⊙ Showing the signal strength v/s channel plot as well.



a) Signal V/S Time Plot

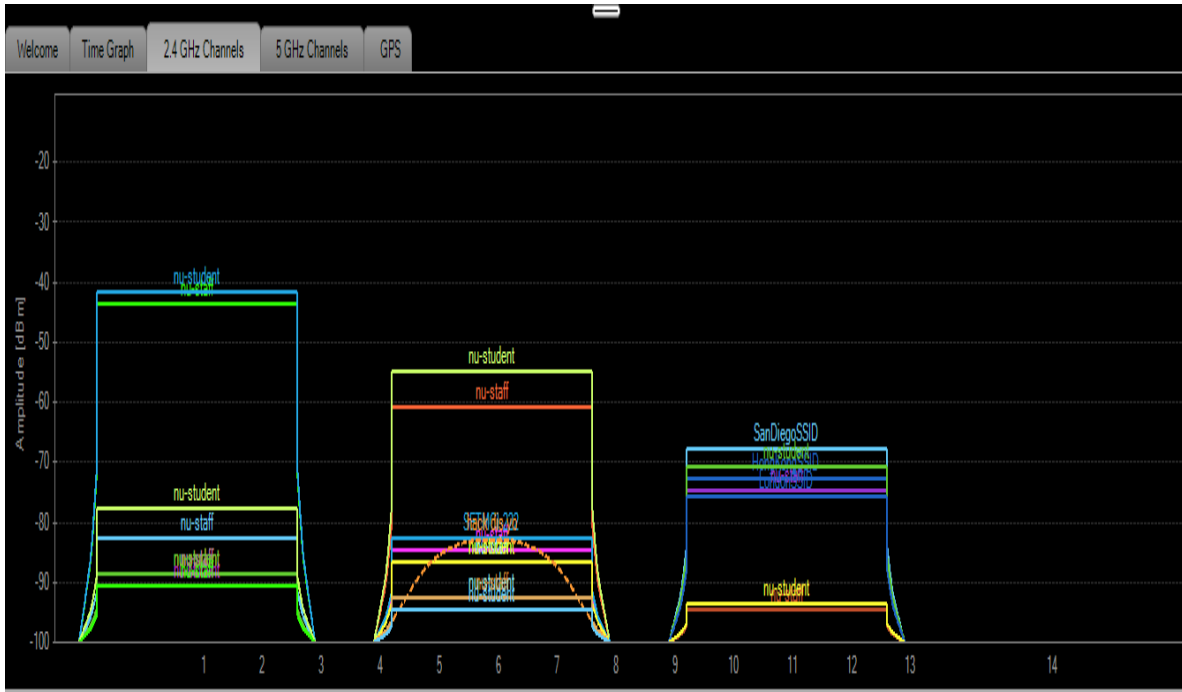

b) RF Conditions Checked at National University (quiet location)

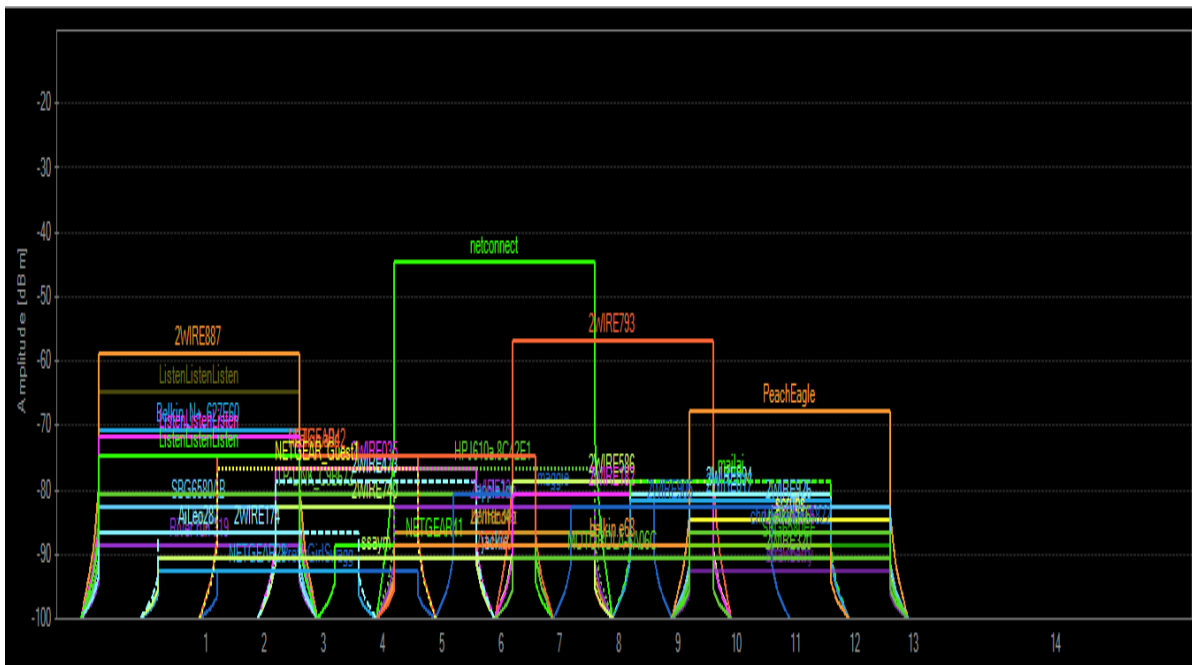

c) RF conditions at Qualcomm Stadium (noisy location)

Figure- 4. Snapshots of Experimental Observations

Figures- 4 a, b & c show a set of snapshots of experimental data. Here a comparison study was done by using two frequency plots 1) National University (quiet) and 2) Qualcomm Stadium (noisy). It is observed from these two plots: Figures-4b & c that RF signal is brighter in noisy location than the quieter location. It was also further observed that the Bluetooth connectivity distances become slightly short with the increase of RF signal noises. From these experimental observations, it is clear that the Easy Tracking system will always be able to detect child's location under any RF conditions and physical barriers.

App Operational Process

Easy Tracking involves proximity gathering information using Android application. Bluetooth was selected as it has wider applications in cell phones and its short coverage helps to reduce the sample pool detection. Other factor that drives the selection of Bluetooth is the power efficiency. Easy Tracking deals with proximity detection. Mobile phones are using this technique for many applications. For example, as we bring the phone closer to our ears (body) the sensor in the phone detects the proximity with the body and dims the background light. It uses GPS to get the location information, Bluetooth for the pairing and SMS to aid the transfer of information regarding GPS. The app has to be started only once, and it keeps on tracking the child by working in the background. The distance between the parent and child is shown in the app at the parent control phone.

It is commonly observed that all smart phones available today are equipped with Bluetooth. That was the main reason it was employed in our application. The parent phone is coupled with the child phone using Bluetooth. The coupling ensures connectivity is established between the child and parent until it is within the range. When the child phone exceeds the connectivity range, coupling is disconnected and an alert in the form of vibration and ring tone starts on the parent phone. If the child comes back into the range the vibration stops.

Most of the mobile phones in today's market are also pre equipped with GPS service. GPS is an important part of our application as it is used to track the child's location. SMS service was used to receive the information about the child's exact position from the child phone. An SMS is sent to and from the parent and child phone every 5 seconds so that the location can be received at the parent phone through the service provider. The GPS map on the parent phone uses two different pointers for the locations of the parent phone and the child phone. An arrow on the map was programmed to show the direction of the child phone location.

Snapshots

Snapshots below (Figure-5) provide the interface photos of Parent and Child phones.

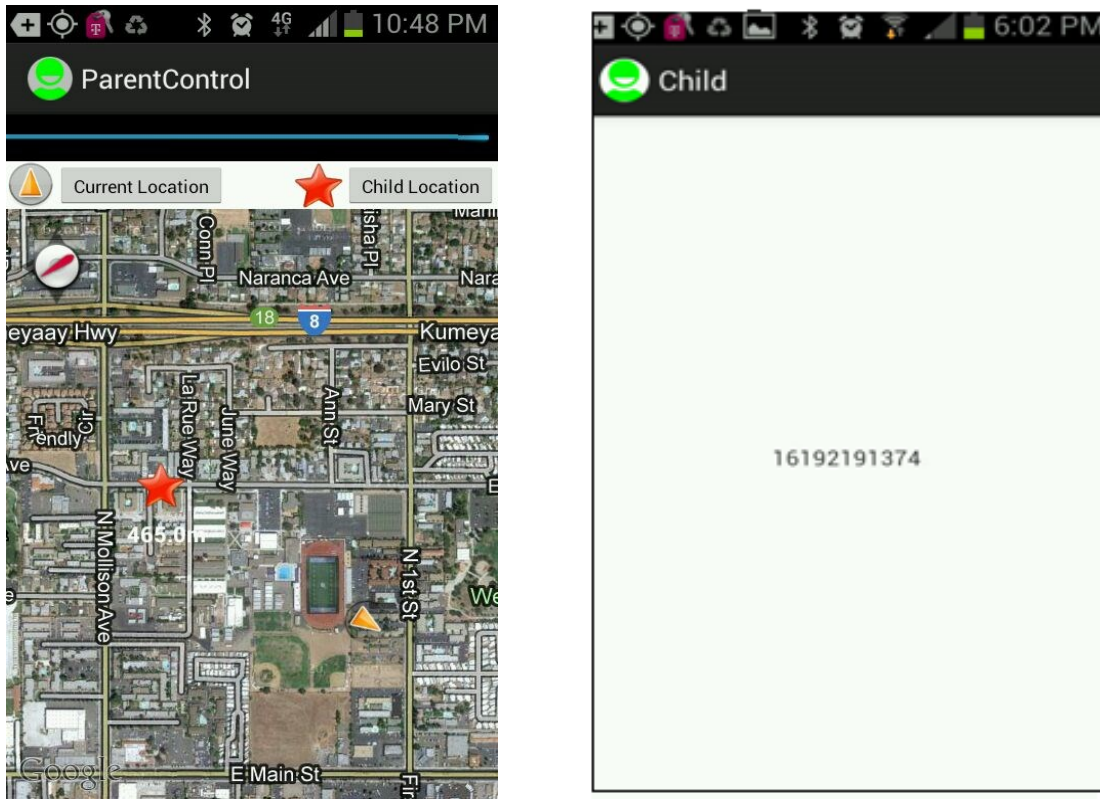

a) Interface Showing Location Of Parent and b) Child Phone Paired With Parent Phone
Figure-5: Parent App Showing the Location of Child with the Distance and Direction

Future Works

The concept of Easy Tracking system is applicable in many other areas including but not limited to the following applications: 1) Social networking- track all the other mobile phone whose Bluetooth mode is switched on, 2) Baggage- track the checked in baggage at the busy airports, 3) Car- track the location of a parked at a big parking lot, 4) Blind Person –help to walk a blind person on the street, 5) Pet- track the movement of pets, and 6) Daycare – track the movements of children in a daycare.

Assessment of Program Learning Outcomes

This project was designed and developed by a group of graduate students at National University under the guidance and supervision of a faculty member. The project was completed within three months. Students applied their theoretical knowledge gained from the Master of Science in Wireless Communications program to design a practical application of the

field and build a prototype for proof of concept. All students in the program are required to complete 10 courses and two Capstone Project courses in order to receive an MS degree in Wireless Communications. In this project, students validate their proof of concepts by building a prototype for demonstration. Students are required to make a formal presentation, a prototype demonstration and submit a written report to the Faculty Judging Panel of five members (two faculty and three industry practitioners in the field). This project was evaluated by the panel using a set of rubrics for all these three phases and received very high scores. All students successfully fulfilled the degree requirements and started working in the field.

Conclusion

Ultimately this project was done to help parents to keep tracking their child's movement constantly in a busy location. The idea behind the Easy Tracking system was extracted from tracking parcels in the past. We made this project more realistic and usable by allowing people to track their precious ones using their phones without importing any other separate devices. This was done by the use of one smart phone on the parent side and another smart phone on the child's side. Of course, we implemented a smart phone on the child's side for convenience and due to time shortage for this project. However, this can be implemented through a compact and cost effective device containing a Bluetooth and GPS chip attached to the child and this idea will be considered for the future work. The tracking process starts by enabling the parent's GPS and Bluetooth services and getting them connected to the child's phone, where these settings should be enabled on the child's phone as well. Once the child goes out of range of Bluetooth, the parent's phone will start vibrating and ringing, then it will locate the child's phone through GPS. It is very convenient for parents to have an application like Easy Tracking to track their children and belongings rather than the use of any other hardware.

References

1. Fred Zahradnik, F. (n,d), Trilateration in GPS, retrieved on 12/01/2012 from <http://gps.about.com/od/glossary/g/trilateration.htm>
2. Pawlowicz, L. (2011), *GPS Track Elevation Profiles With 3DEM*, retrieved on 11/30/2012 from <http://freegeographytools.com/2007/gps-track-elevation-profiles-with-3dem>
3. Malin De Silva, M., (May 2010), Phone Location Tracking, retrieved on 11/20/2012 from <http://notesofgenius.com/gps-applications/>
4. Londersele, B., Delafontaine, M., and Nico Weghe, N. (April 2009). Bluetooth Tracking: A Spy in your Pocket, Vol. 23 (11), retrieved on 11/05/2012 from http://www.gim-international.com/issues/articles/id1443-Bluetooth_Tracking.html
5. Vainio, J. (May 2000). Bluetooth Security. Helsinki University of Technology. Retrieved on 01/01/2013 from http://www.cse.tkk.fi/fi/opinnot/T-110.5190/2000/bluetooth_security/bluesec.html.
6. Bellis, M. (n,d). History of the Global Positioning System – GPS, retrieved on 12/05/2012 from <http://inventors.about.com/od/gstartinventions/a/gps.htm>

7. 7. "How Bluetooth Technology Works". Bluetooth SIG. Archived from the original on 17 January 2008. Retrieved 12-02-12.
8. inSSIDer (2013), Get the Best Wi-Fi Scanner, retrieved on 12/03/2012 from <http://www.metageek.net/products/inssider/>
9. Ostrander, J., (2012). Android UI Fundamentals Development and Design, Peachpit Press, Berkeley, CA
10. Deitel, P., Deitel, H., Deitel, A., and Morgano, M., (2012). Android for Programmers an App-Driven Approach, Prentice Hall, Upper Saddle River, NJ
11. Darcey, L and Conder, S., (2011). Android Wireless Application Development, 2nd Edition, Addison Wesley, Upper Saddle River, NJ
12. Deitel, P. and Deitel, H., (2011), Java How to Program (early objects) 9th Edition, Prentice Hall, Upper Saddle, NJ
13. Savitch, W., (2011). Java: An Introduction to Problem Solving and Programming, 6th Edition, Addison-Wesley

Acknowledgement

We are grateful to our National University students, professors, reviewers, Advisory Board members, Faculty Judging Panel members, and companies that allowed students to visit, sponsored some projects, donated money and equipment, and hired our MSWC graduates.

Authors' Biographies

Mohammed Alani, Student, MS Wireless Communications Program, School of Engineering, Technology and Media, National University, San Diego, California, md_alani@yahoo.com
Major research interests: Wireless communications, sensors

Alaa Ayoob, Student, MS Wireless Communications Program, School of Engineering, Technology and Media, National University, San Diego, California, Sk2005ah@Yahoo.com
Major research interests: Wireless communications, sensors

Jino Raj Xavier, Student, MS Wireless Communications Program, School of Engineering, Technology and Media, National University, San Diego, California, jinorajxavier@gmail.com
Major research interests: Wireless communications, sensors

Sameeullah Sharief, Student, MS Wireless Communications Program, School of Engineering, Technology and Media, National University, San Diego, California, samee432@gmail.com
Major research interests: Wireless communications, sensors

Mohammad Amin, Ph.D.

Professor and Lead for the MS Wireless Communications Program, School of Engineering, Technology and Media, National University, San Diego, California, mamin@nu.edu, Tel: (858)309-3422, Fax: (858)309-3419
Major research interests: Wireless communications, database, sensors, Engineering Education.

Marcos Turquetti, Ph.D.

Adjunct Faculty, MS Wireless Communications Program, School of Engineering, Technology and Media, National University, San Diego, California, Marcos.Turquetti@natuniv.edu
Major research interests: Wireless communications, database, sensors

Pradip Peter Dey, Ph.D.

Professor and Lead for the MS in Computer Science Program, School of Engineering, Technology and Media,
National University, San Diego, California, pdey@nu.edu, Tel: (858)309-3422, Fax: (858)309-3419

Major research interests: Computer Science, Software Engineering, Mathematical Reasoning, Engineering
Education.

Framework for Sustainability Practices in Construction Education Curriculum using BIM

Jin-Lee Kim, Ph.D., P.E., LEED AP BD+C
Department of Civil Engineering & Construction Engineering Management,
California State University Long Beach,
1250 Bellflower Blvd., Long Beach, CA 90840 - U.S.A
Email: jinlee.kim@csulb.edu

Abstract

This paper presents a framework to develop a unique and innovative virtual approach in order to deliver sustainability practices using Building Information Modeling (BIM) technology for undergraduate students and implement it as a new hands-on laboratory- and project-based course in the construction education curriculum. The demand for specialists in these two emerging fields is increasing tremendously due to the fact that green buildings education, research, and practice issues are becoming driving forces in academia and industry. The BIM-based teaching approach developed in the previous study is a stepping stone for the proposed innovative virtual approach. The BIM will provide students with building models containing integrated architectural information to implement sustainability that goes beyond both conventional 2D solutions using electronic drafting board and 3D modeling for purely visualization purposes. Therefore, it is expected that students enhance learning ability of sustainability through an innovative virtual approach using BIM. As an effort, this paper mainly focuses on a proposed framework to bridge the gap between the current theoretical courses and hands-on experiences. The ultimate goal of this research project is to inspire undergraduate students with green buildings associated with BIM for the sustainable development of a built environment.

Introduction

The AEC/FM industry is accelerating sustainability in built environment. The industry now heavily relies on the integrated sustainable design and construction and computer-aided automated solutions. To meet the challenges and opportunities for future employment, the integrated and practical sustainable building education is heavily required for construction engineering management students. Thus, the need for skilled and knowledgeable project managers must be addressed to survive in a competitive environment. The demands for the two emerging fields have been clearly outlined in the previous studies on BIM technology^{1, 3, 4, 5, 14, 17, 28} and sustainability in construction education^{2, 10, 12, 13, 15, 16}, respectively. A recent research recommended that a study of sustainable or green construction needs to be added to the Construction Management curriculum in the context of estimating, scheduling, and building techniques, to prepare Construction Management professionals for construction in the 21st century.²¹

Practical sustainable buildings education is needed for construction engineering management students destined for employment in the AEC/FM industry. The ultimate goal of this research project is to develop a new, innovative instructional approach on sustainable buildings for

undergraduate students and implement it as a hands-on laboratory- and project-based course using BIM technology. This innovative course is unique in construction education curriculum in the sense that these two revolutionary movements will create environmentally friendly design and construction through a streamlined process and it will help students to deeply understand the construction processes by using sequential computerized simulation and modeling.

Sustainability in Built Environment

Over the past decade, the importance of accelerating sustainability in a built environment has been well recognized all over the world. The World Commission on the Environment and Development offered the best definition for sustainable design as “Sustainable development meets the needs of the present without compromising the ability of future generations to meet their own needs.”²⁶ The built environment consumes about 40 percent of extracted resources in most industrialized countries, as well as consuming approximately 40 percent of all primary energy.⁶ According to the U.S. Green Building Council, buildings are responsible for 38% of carbon dioxide emissions, 71% of electricity consumption, 39% of energy use, 12% of water consumption, and 40% of non-industrial waste in the U.S.²⁴ Green building has been developed as a practical answer to the environmental and health burdens of the built environment.

McDonough and Braungart developed the concept of cradle-to-cradle design to follow nature’s model of eco-effectiveness based on Five Steps.²⁹ The concept has been popularized because it provides a framework for designing materials and products, and focuses attention on waste and on the proliferation of toxic substances. Sustainable and high performance buildings and infrastructures have shown dramatic increases in the U.S.A. The growing need for professionals with specific training in sustainable building practices will increase significantly over the next decade. Thus, undergraduate students need to advance their career and maintain their competitive edge with training in the green building areas.

Sustainability in Construction Education

Many schools, with undergraduate engineering programs in many disciplines, attempt to include environmental sustainability and sustainable design in their curricula.¹⁸ The challenges and opportunities are laid out in CEM disciplines as to how to incorporate sustainability into their educational formation.^{6, 18, 19, 25} Russell et al. reviewed the past and present of construction engineering and prescribed practical change to revitalize construction engineering education to meet future demands.¹⁹ Kelly proposed an approach to general education for civil engineers, which showed that sustainable development is a good theme for a civil engineering program.⁶ Pocock et al. proposed a problem-oriented approach to incorporating sustainable design into a construction engineering curriculum.¹⁸ Wang shared the experience gained from developing and teaching a sustainability course by identifying sustainability knowledge areas, course planning, and lessons learned from the class. The study recommends that engineering educators need to develop appropriate class content and effective teaching techniques to prepare students with sustainability knowledge and techniques.²⁵ From the standpoint of the education situation, sustainability issues should be incorporated into the construction engineering management education curriculum to respond to the needs of the industry.

Building Information Modeling in Construction Education

Building Information Modeling (BIM) is an emerging tool in the design industry used for design and documentation. BIM is also used as a vehicle to enhance communication among all the project stakeholders.¹¹ BIM is a comprehensive, integrated graphic and alphanumeric database, through which the collaboration among the stakeholders can be effectively achieved.²² BIM is a methodology of continuous refinement. One needs to understand the process and workflow, make gradual changes and enhancements to the individual project process to achieve better results, and repeat the concepts for innovation and best performance.¹¹ BIM modeling and analysis requires higher training efforts because it might be more difficult, for people who were previously 2D users, to learn the BIM approach and to handle complex geometry such as freedom structure. The development of BIM triggers a new approach to teaching and learning at architecture, engineering, and construction schools. However, the lack of personnel with BIM skills is a significant constraint retarding use of the technology in the AEC/FM industry.²⁰ Berwald compared a class of students using BIM programs with a class of students who were using traditional 2-D CAD programs. The study showed the different experiences of each method and contrasted the efficiency of both 2D and BIM.⁴ Barnes and Castro proposed a BIM-enabled integrated optimization tool for LEED decisions.² The construction educator should encourage construction engineering management students to acquire the skills and knowledge of the BIM technology as more AEC companies integrate BIM into their fields and require the new labor force to be able to collaborate and communicate with 3D/4D/5D BIM technologies.

Research Project Objectives

This paper aims to develop a unique and innovative virtual approach to deliver sustainability using BIM technology for undergraduate students and implement it as a new hands-on laboratory- and project-based course in construction education curriculum. The intended contribution is to influence undergraduate students with green buildings associated with BIM for the sustainable development of a built environment. The proposed approach is unique in that it covers both sustainability and BIM in a single undergraduate course as the two subjects are currently taught in separate courses in the nation. The objectives of the proposed project are as follows:

- (1) To attract students with an interest in BIM technology and sustainability,
- (2) To prepare students for employment in the AEC/FM industry such as BIM, LEED (Leadership in Energy and Environmental Design), preconstruction services, and project risk management, including ethical, environmental, and sustainability concerns,
- (3) To train the students on the application and techniques of BIM technology to provide a fundamental theory and application to the students' approach to solving the problems encountered in the workplace,
- (4) To encourage a team approach in the laboratory process simulation to develop skills and learn the importance of collaboration efforts rather than individual advancement, especially in emerging technology fields in the AEC/FM industry,
- (5) To provide students with sustainable building toolkits designed specifically for the needs of the construction industry including internship programs for undergraduate students.

Proposed Laboratory-based Teaching Framework for Sustainability

This section describes the proposed laboratory-based teaching framework for sustainability. The framework will make a stepping-stone of the BIM-based teaching approach that has been developed in the previous study.⁸ The BIM-based teaching approach integrates BIM technique into an existing course to enhance students' ability to visualize the building projects from the foundation to the roof. Figure 1 shows the framework of the BIM-based teaching approach and illustrates the sequence of the approach, the tool needed to implement each step, and the deliverable produced as a result of each step. The BIM-based teaching approach begins with the understanding of the physical models for residential buildings (See Figure 2). 2D drawings are then generated based on the physical models using traditional Computer Aided Design (CAD) programs. 3D BIM model is finally developed to better understand the buildings in detail and to accurately takeoff the material quantities.

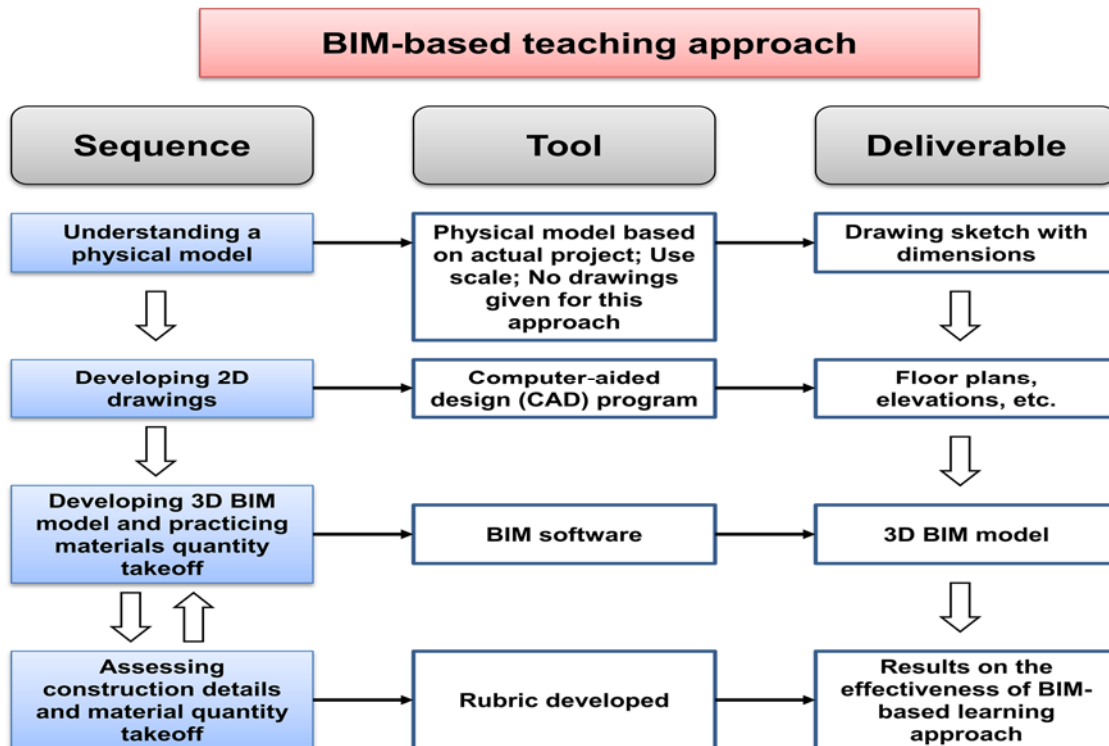

Figure 1. Building information modeling-based teaching approach⁸



Figure 2. Working on a physical model

Laboratory-based Teaching Framework for Sustainability

The proposed teaching framework for sustainability consists a 16-week laboratory- and project-based course for a 3-hour credit unit. Figure 3 shows the schematic diagram for fifteen new hands-on laboratory- and project-based course modules.

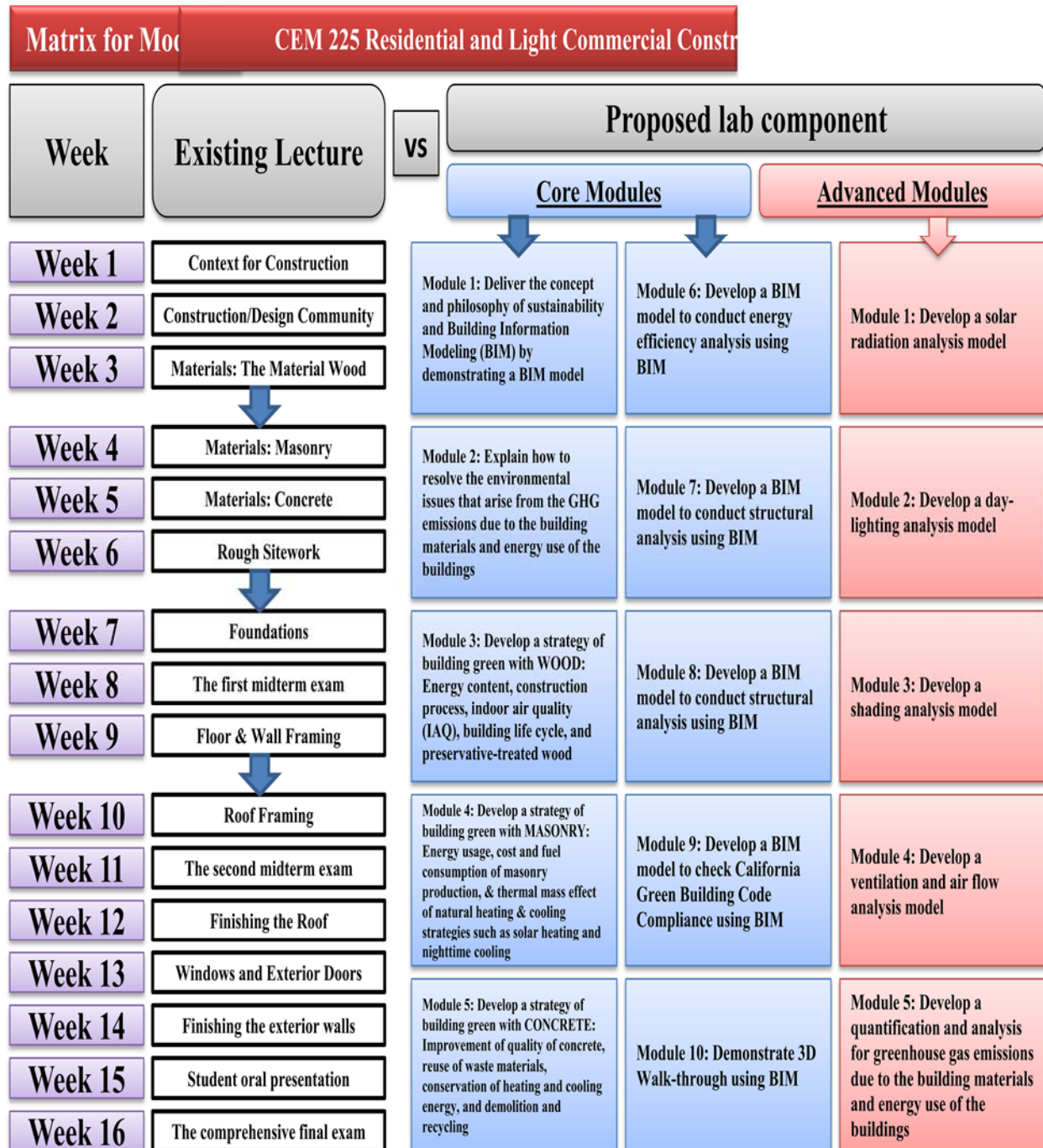

Figure 3. Schematic diagram for the proposed framework

The first five weeks (15 hours) will be devoted to the foundations and effects of green resources such as building materials, building forms, and building systems, on the green buildings. The next six weeks (18 hours) will be devoted to hands-on laboratory-based work. In the second six weeks, the applications and techniques of BIM technology will be studied through experiments that create the BIM model and closely simulate the effects of green resources on the building projects. The last five weeks (15 hours) will be devoted to hands-on project-based work to understand the relationships between BIM technology and sustainability. In these last weeks, how these two revolutionary movements will change the way the construction business operates and transform traditional processes into new workflows will be discussed, so that green solutions from the beginning of the project can be achieved in the AEC/FM industry. Also, guest lectures on sustainability, BIM technology, ethics, and green markets potential will be delivered.

Implementation Strategy

In light of the incorporation of sustainability into the BIM-based teaching approach, three main strategies are implemented. First, the use of building materials is a constant in the AEC/FM industry, regardless of how much we do not use energy nor consume water. Building materials such as wood, masonry, concrete, steel, and others have significant effects on sustainability. The fundamental knowledge of building materials falls into four major building materials: wood, masonry, concrete, and steel. EPA defines green building as the practice of creating structures and using processes that are environmentally responsible and resource-efficient throughout a building's life-cycle.²³ A recent research assessed the evolution of students' understanding of sustainability and revealed that the selected group of students made progress in understanding during a Sustainable Construction course by using problem-based and service-learning type projects.⁹ Building with wood and masonry has several areas for sustainability implementation, including energy content, construction process, indoor air quality (IAQ), building life cycle, and preservative-treated wood. Building with concrete also has several possibilities, which include aggregates and water, wastes, formwork, reinforcing, demolition, and recycling. Second, to implement the sustainability in a built environment, the understanding for simple design concepts is required for a more sustainably driven outcome. A hands-on laboratory experiment procedure and manual being developed addresses the three main areas: building orientation, building massing, and day-lighting. The impact of climate, how to reduce resource need, how to use BIM to find solar south, how to use BIM for building massing, how to optimize the building envelope, and how to analyze the daylight will be studied and understood at the project level. Finally, to examine the relationship between sustainability and building systems, the understanding for building systems is also required for a more sustainably driven outcome. The manual also addresses the three main areas: water harvesting, energy modeling, and renewable energy. How to analyze and optimize water harvesting using BIM, how to conduct energy analysis using BIM to reduce energy needs, and how to analyze renewable energy and optimize a solar array to reduce energy needs are studied at the project level.

Concluding Remarks

This paper presents a framework to develop a unique and innovative virtual approach to deliver sustainability using Building Information Modeling (BIM) technology for undergraduate students and implement it as a new hands-on laboratory- and project-based course in the

construction education curriculum. The concrete outcomes from this research project are fifteen 3-hour laboratory- and project-based course modules in teaching sustainability using BIM, which is designed to cover a semester. The outcomes of this project will provide a needed component of practical sustainable buildings education for students destined for employment in the AEC/FM industry because the industry is becoming reliant on the integrated sustainable design and construction with BIM technology. Students in the proposed course are expected to gain (1) understanding green resources such as building materials, building forms, and building systems, (2) hands-on experience with BIM, especially 3D geometric models instead of 2D CAD designs, and (3) hands-on experience with the effect of green resources on the projects using BIM analysis tools. Students are expected to build strong foundations for understanding global environmental problems such as climate change and ozone depletion, being familiar with the concept of building assessment, gaining a clear understanding about sustainable development and sustainable construction, and help students understand the relationships between sustainability and building materials, building forms, and building systems, using BIM technology. The visualization approach using BIM will enable students to implement high-performance green building strategies to explore how the buildings would be “greened.”

Acknowledgment

This material is based upon work supported by the National Science Foundation under Grant No. DUE-1140941. Any opinions, findings, and conclusions or recommendations expressed in this material are those of the author and do not necessarily reflect the views of the National Science Foundation.

References

1. Aslani, P., Griffis, F. H., and Chiarelli, L. (2009). “Building information model: The role and need of the constructors.” *2009 Construction Research Congress*, Seattle, WA, pp. 467-476.
2. Bae, J.-W., and Kim, Y.-W. (2009). “Assessing the environmental impacts of lean supply system: A case study of rebar supply in high-rise condominium construction projects.” *2009 Construction Research Congress*, Seattle, WA, pp. 1009-1018.
3. Barak, R., Jeong, Y.-S., Sacks, R., and Eastman, C. M. (2009). “Unique requirements of building information modeling for cast-in-place reinforced concrete.” *Journal of Computing in Civil Engineering*, 23(2), pp. 64-74.
5. Berwald, S. (2008). “From CAD to BIM: The experience of architectural education with building information modeling.” *Proceeding of Architectural Engineering Conference*, Sept. 25-27, Denver, CO.
6. Denzer, S., and Hedges, K. E. (2008). “From CAD to BIM: Educational strategies for the coming paradigm shift.” *Proceeding of Architectural Engineering Conference*, Sept. 25-27, Denver, CO.
7. Kelly, W. E. (2008). “General education for civil engineers: Sustainable development.” *Journal of Professional Issues in Engineering Education and Practices*, 134(1), pp. 73-83.
8. Kibert, C. J. (1999). *Reshaping the Built Environment: Ecology, Ethics, and Economics*. Washington, D.C., Island Press.
10. Kim, J.-L. (2012). “Use of BIM for effective visualization teaching approach in construction education,” *Journal of Professional Issues in Engineering Education and Practice*, ASCE, Vol. 138, No. 3, pp. 214-223.
11. Klotz, L., and Grant, D. (2009). “A balanced view of sustainability in civil engineering and construction.” *2009 Construction Research Congress*, ASCE, Seattle, WA, pp. 1338-1347.
12. Klotz, L., Horman, M., and Bodenschatz, M. (2007). “A lean modeling protocol for evaluating green project delivery.” *Lean Construction Journal*, 3(1), pp. 1-18.

13. Krygiel, E., and Nies, B. (2008). *Green BIM: Successful sustainable design with building information modeling*, Wiley Publishing, Inc., Indianapolis, Indiana.
14. Lapinski, A. R., Michael, J. H., and David, R. R. (2005). "Delivering sustainability: Lean principles for green projects." *2005 Construction Research Congress*, April 5-7, San Diego, CA, pp. 27-31.
15. Lapinski, A. R., Michael, J. H., and David, R. R. (2006). "Lean processes for sustainable project delivery." *Journal of Construction Engineering and Management*, 132(10), pp. 1083-1091.
16. Livingston, C. (2008). "From CAD to BIM: Constructing opportunities in architectural education." *Proceeding of Architectural Engineering Conference*, Sept. 25-27, Denver, CO.
17. Magent, C. S., Riley, D. R., and Horman, M. J. (2005). "High performance building design process model." *2005 Construction Research Congress*, April 5-7, San Diego, CA.
18. Nahmens, I. (2009). "From lean to green construction: A natural extension." *2009 Construction Research Congress*, Seattle, WA, pp. 1058-1067.
19. Napal, M. P., Zhang, J., Webster, A., Staub-French, S., Pottinger, R., and Lawrence, M. (2009). "Querying IFC-based building information models to support construction management functions." *2009 Construction Research Congress*, Seattle, WA, pp. 506-515.
20. Pocock, J. B., Mitchell, Z., and Bates, A. J. (2009). "One approach to incorporating sustainable design into undergraduate engineering programs." *2009 Construction Research Congress*, Seattle, WA.
21. Russell, J. S., Hanna, A., Bank, L. C., and Shapira, A. (2007). "Education in construction engineering management built on tradition: Blueprint for tomorrow." *Journal of Construction Engineering and Management*, 133(9), pp. 661-668.
22. Sacks, R., and Barak, R. (2010). "Teaching building information modeling as an integral part of freshman year civil engineering education." *Journal of Professional Issues in Engineering Education and Practice*, 136(1), pp. 30-38.
23. Siddiqi, K. M., Chatman, D., and Cook, G. (2008). "Role of education and industry towards more sustainable construction." *International Journal of Environmental Technology and Management*, 8(2/3), pp. 310-321.
24. Thomsen, C. (2008). *Program management: Concepts and strategies for managing capital building programs*, CMAA, McLean, VA.
25. U.S. Environmental Protection Agency (2008). "Lean in Government Starter Kit." (Last updated on Tuesday, April 13, 2010). <http://www.epa.gov/lean/starterkit/resources/Lean-Starter-Kit.pdf> (Retrieved May 2, 2010).
26. U.S. Green Building Council. (2007). *Green Building Research Funding: An Assessment of Current Activity in the United States*.
27. Wang, Y. (2009). "Sustainability in construction education." *Journal of Professional Issues in Engineering Education and Practice*, 135(1), pp. 21-30.
28. WCED 1987 World Commission on the Environment and Development (<http://www.worldinbalance.net/intagreements/1987-brundtland.php>) (Retrieved on May 19, 2010).
29. Weber, D., and Hedges, K. E., (2008). "From CAD to BIM: The engineering student perspective." *Proceeding of Architectural Engineering Conference*, Sept. 25-27, Denver, CO.
30. Wenfa, H., and Xinhua, H. (2008). "A case study of collaborative education based on building information model." *Proceedings of International Conference on Computer Science and Software Engineering*, CSSE, 5, pp. 198-201.
31. McDonough, W., and Braungart, M. (2002). *Cradle to Cradle: Remarking the Way We Make Things*. New York: North Point Press.

Professional Practice and the Engineering Curriculum

Paul M. Jones, J. Richard Phillips
Corporate & University Relations Group/ Harvey Mudd College

Abstract

There are elements of professional practice common to the engineering profession in all engineering fields. However, many, if not most, engineering academic curricula allow little or no room for professional practice other than minimal capstone projects. In those that do, the approach is widely scattered. The purpose of this paper is three-fold: (1) To briefly describe a professional practice program (featuring sponsored senior design projects) as adopted by California State University, Los Angeles (CSULA); (2) To discuss difficulties encountered in establishing such programs nationwide; and (3) To highlight the benefits and other facets of the Strategic Corporate Alliance Initiative at CSULA. We believe that first and foremost, a professional practice program will provide students with the experience of working on interdisciplinary team-based projects. (Virtually all engineering graduates entering the professional workplace will work in interdisciplinary teams.) It is vital that the projects be real-world projects suggested and funded by an outside sponsor. Moreover, the team project experience should extend beyond a one or two semester capstone course. Paul Jones and his colleagues at Corporate & University Relations Group have implemented custom Strategic Corporate Alliance Initiatives at CSULA, Arizona State Polytechnic University, and U. C. Santa Cruz that feature adaptations of the Harvey Mudd (HMC) Clinic model. The goal of a professional practice program should be to prepare students for engineering practice in all its aspects: technical and social. Resistance to incorporating professional practice into an existing curriculum takes many forms. This includes a natural resistance to change and inadequate rewards to faculty for teaching and advising team-based projects, especially sponsored senior design (capstone) projects. For those institutions interested in a professional practice program, there are a number of other academic issues to be overcome. For example, there may be concerns about teaching credit for project advising, and course credit for students. Different departments at the same university can differ widely on these issues. Also, some departments will have a one-semester capstone course while for others it might be a one-year course. These complications may preclude carrying out sponsored interdisciplinary projects.

Senior Projects in the CSULA Professional Practice Curriculum

Howe and Wilbarger¹ in their 2005 National Survey of Capstone Courses report that 67% of respondents state that their average direct cost per project is from \$1 to \$1,000, while only 5% reported costs above \$5,000. At CSULA engineering student team budgets

Proceedings of the 2013 American Society for Engineering Education Pacific Southwest Conference
Copyright © 2013, American Society for Engineering Education

(supplies, hardware, software, travel etc.) typically exceed well over \$5000, which enables students to solve much more challenging open-ended problems.

The essence of the CSULA Professional Program is a series of sponsored student-team projects. We assert that students perform to their best ability and receive the most educational benefits when they are working with a real customer and are working to meet the needs of the customer. Here we describe the nature of these projects.

Scope of Work: To ensure that each senior design team is engaged in a project that is both challenging, and has a high likelihood of success, it is recommended that the sponsoring organization submit several project ideas to help ensure that a suitable project will result. The design problem should be a real open-ended problem and be important, but not on the critical path for the sponsor. It should be a problem that makes sense for a sponsor to outsource.

A team of four students is assigned to each project, and each student will work, on average, 10 hours per week on the project for the full September – June academic year. The total project effort will be roughly 1200 person hours (30 weeks).

Project Liaison: The liaison is most important. He/she represents the sponsor and ideally should be a stakeholder in the outcome of the project. He/she should be knowledgeable about the needs of the company with respect to the project requirements and often serves as the domain expert for the student team. Additionally, the liaison should understand that his/her organization is supporting students and must be aware of the educational needs of the students, as well as the needs of the company.

The liaison should be able to commit to a conference call with the team each week. He/she should plan to meet with the team multiple times during the academic year and should also plan to host the team for a company site visit early into the project. This is to help students become familiar with the context of their project and to help the team establish a customer relationship with their sponsor.

Program Timeline: The schedule for projects is constrained by the academic calendar. On Senior Project Launch Day all company sponsor liaisons are expected to come to campus and to meet with their respective teams. The purposes of this meeting are to build rapport with the team; to present the problem in greater detail, and to allow for clarification of the requirements and constraints on the solution; to agree to the schedule for the first term, including timing of weekly conference calls; and to provide background on the problem to bring the team up to speed.

The first “student deliverable” is a work statement for the project. This includes the scope of work for the project, and contains a clear statement of the project goal in the students’ words. This work statement should be completed about five weeks after the initial launch date. After review, the sponsor might modify the work statement. The purpose is to arrive at an agreed-on project goal. The remaining three project phases (conceptual design; preliminary/final design; prototype/test) flow from the work statement, and will vary from project to project.

A design review is typically scheduled sometime between December and January and is normally held at the sponsor’s site. The purpose is to agree on the conceptual design of the sponsored project. (Senior technical managers are encouraged to attend.) This is followed by all of the remaining project elements: finalizing the design, prototyping, testing, and data analysis.

The project culminates when all teams present their findings at a celebratory event at the end of the academic year. Students are then expected to deliver a final report, and if relevant, present their results at the sponsor site.

Difficulties in Establishing a Professional Practice Program

Resistance to incorporating professional practice into an existing curriculum takes many forms. There is a prevailing resistance to curriculum reform at all colleges and universities. Furthermore most universities are dominated by research, and may have little interest in a professional practice undergraduate program. For those institutions that are interested, there are still challenges remaining. A primary one is the attitude of the engineering faculty who will set the tone for the professional engineering program and, in the end, will determine its success or failure. The fact that advising student-team projects is a different form of teaching, but is no less important than conventional classroom teaching, is often not recognized.

Academic Issues: There are a number of academic issues involved in introducing professional practice to the engineering curriculum. The first concerns teaching credit for project advising. That is, what course equivalent is given for advising projects in the teaching schedule? At Harvey Mudd College advising two Clinic projects in a semester is deemed to be equivalent to teaching one course (of three) in a semester.

Project advising should be embedded in the teaching schedule, not an add-on. Proper credit should be awarded for this very important type of teaching. One or two people advising 40 projects in a capstone course leads to superficial results.

Ideally, the important task of project advising should be shared by all members of the teaching faculty; not be assigned to a committed few. The same faculty members who teach engineering science should also serve as project advisors. This is part of recognizing the importance of project learning (and professional practice) for faculty and students, as well as the administration. The use of clinical professors with industry experience will often compliment tenured faculty as professional practice instructors and project team advisers.

Another consideration is conflict of interest. Many faculty members may have active consulting practices. Advising of sponsored projects is a source of potential conflict. To some extent, this is a matter of personal integrity. At HMC this has not been a problem. Faculty members have found the two activities to be reinforcing. Many with consulting practices have brought in sponsored projects through their consulting. And consulting has improved faculty skills in managing projects, and interacting with students, as well as bringing real-world experience to campus.

The Strategic Corporate Alliance Initiative at CSULA

The Strategic Corporate Alliance is a partnership between CSULA and strategic corporate partners. CSULA was awarded the prestigious Excellence in Engineering Education Collaboration Award by the Corporate Member Council of the American Society of Engineering Educators at the February 2012 ASEE/CIEC Annual Conference. The Aerospace Corporation, The Boeing Company and Northrop Grumman Corporation were recognized as members of the ASEE Corporate Members Council as founding sponsors/partners of the CSULA College of Engineering, Computer Science, and Technology (ECST) Professional Practice Program.

Invitation to Industry: The College of Engineering, Computer Science, and Technology at California State University, Los Angeles (CSULA), invites your organization to become a member of the CSULA Strategic Corporate Alliance. The purpose of the Strategic Corporate Alliance is to create highly engaging and relevant corporate and university partnerships in order to jointly establish CSULA as a recognized world class provider of professional practice experiences for its engineering and computer science students. The program aims to enhance the recruitment, retention and graduation of high-potential students that are fully prepared to enter the professional workforce.

Description: CSULA is beginning the fifth year of the Strategic Corporate Alliance Initiative. Programs that have been developed and supported through the Strategic Alliance include an award-winning sponsored Professional Practices Program, a sponsored Corporate Scholars Program, and an Executive in Residence Program. Key

programs under development include an enhanced summer transition program for first-year students (STEP-LA), and a curriculum redesign committee that will continue to revise the curriculum to be more hands-on and industry focused.

Members of the Strategic Corporate Alliance Initiative are asked to donate between \$5,000 to \$25,000 to support and enhance current programs, as well as to help launch new and innovative programs that will help students succeed in the Engineering, Computer Science, and Technology professions upon graduation. Members will hold a seat on the Dean's Advisory Board and become a stakeholder in the development of such programs.

CSULA strives to be recognized as one of the leading universities for providing corporate partners/investors with their highest return on investment for sponsored projects, research, student programs, and recruiting. In addition to becoming a strategic alliance partner, one is invited to participate in one or more of the programs offered below by the CSULA College of Engineering, Computer Science, and Technology:

Undergraduate Professional Practice Program: As detailed earlier, the purpose of the Undergraduate Professional Practice Program is to provide students with a capstone experience, in which they apply their theoretical knowledge to real applications. The program exposes students to an industry setting, where students work with a real client (industry partner) to solve a client-defined problem. The result may be a physical prototype, software package, or operational algorithm. Regardless of project type, student teams are expected to meet the needs of their client, and deliver a product at the end of the academic year. Projects involve teams of four or five engineering/computer science, or technology students, and a faculty advisor working on a real customer problem for a full academic year (1200 hours per team minimum). Faculty and staff support the efforts of the student-led professional practice teams that solve the problems for the customer. The sponsor will have full use of the results.

The college launched the Professional Practice Program in 2008 with nine founding corporate partners: The Aerospace Corporation, The Boeing Company, DirecTV, Heateflex, Los Alamos National Laboratory, Northrop Grumman Electronic Systems, Northrop Grumman Integrated Systems, Pratt & Whitney Rocketdyne, and Southern California Edison. In its second and third year, the college welcomed new partners that include: EmCycle, Medtronic MiniMed, Naval Surface Warfare Center-Corona, Space Systems Loral, Southern California Gas Company, Raytheon, and the United Parcel Service (UPS).

Several elements make these projects like an actual work experience. First, the industrial partner specifies the open-ended problem. It is a real problem that needs to be solved.

Second, the team is self-managed by the students. Although there is a faculty advisor and a recognized student team leader, each student has a leadership role and the responsibility to make sure the team functions well. This simulates many work situations. Finally, the industrial liaison is the customer for the team.

The team must react to changing information as the year progresses. The skills of negotiating, project planning; presenting, adjusting to changing conditions, and writing reports, are all needed in the workplace, but often are not sufficiently taught to undergraduate engineers. The Professional Practice project is much more like an industrial experience than any other course situation. Students are exposed to the skills required to be a professional engineer.

The self-sustaining, exemplar Professional Practice Program has allowed the College of Engineering, Computer Science, and Technology at CSULA to join a small but elite group of colleges and universities such as Harvey Mudd and Olin that are recognized leaders in professional practice preparation of graduating engineers. Sponsors are asked to provide funding in the amount of \$25,000 per project and provide a stakeholder liaison to have weekly contacts with the team.

Corporate Scholars Program: The objective of the Corporate Scholars Program is to establish CSULA as the go-to university for recruiting, retaining, and graduating the highest-potential, industry-ready engineering and computer science students. In addition to a focus on women and underrepresented minority students, a distinguishing feature is the extensive involvement of corporations and student organizations in developing a world-class experiential program that compliments the Professional Practice Program described earlier.

As a result, a student council was formed, comprised of students from each Engineering, Computer Science, and Technology discipline. All sponsors are honored at a Corporate Scholars Day/Strategic Alliance meeting. A key element of this day is the one-on-one networking sponsors will have with their scholarship recipients and other scholars within the college. The ECST student council, along with its 23 student organizations, focuses on developing various activities and events in collaboration with their corporate partners. Each year, the ECST student council hosts Engineering Week, ECST Career Fair, and Career-Awareness Day.

Career-Awareness Day presents to minority students a wide array of career possibilities in the engineering, computer science, and technology fields. CSULA is the only minority-serving institution (MSI) in the Western United States, with an ABET accredited engineering program with Hispanics and African Americans constituting about 60% of the enrollment. With that said, we believe that this event and ongoing student activities with partner companies are necessary because role models in the technical fields are not readily accessible to the population of students that served.

Corporate partners are asked to contribute a minimum of \$5,000 to a scholarship pool and \$2,000 for student organizations to offset the cost of organizing the aforementioned activities, and other student-related activities. Ongoing support of this program ensures that sponsors are engaged with student organizations on campus including SWE, SHESS, NSBE, Tau Beta Pi, etc.

Exceptional benefits begin accruing to corporate sponsors immediately. They have the opportunity to establish relationships with a very bright and motivated contingent of current engineering, computer science, and technology students. Active participation in the ongoing development of this exemplar program will increasingly assure that CSULA will provide an important cost-effective solution for each corporate partner/sponsor in achieving its recruiting goals.

Executives in Residence: The Executives in Residence Program integrates professional employees and retirees from corporations and government into the curriculum at CSULA. Executives in Residence may work full-time or part-time teaching classes, conducting research, and mentoring students. Executives in Residence also mentor graduate and undergraduate Professional Practice projects.

The knowledge executives have in their respective fields through their certification process and their industry experiences, is an invaluable asset to the college and the students. Their participation directly impacts the mission of the College of ECST: which is to provide students with a world class applied Engineering, Computer Science, and Technology experience.

Conclusions

The most meaningful facet of Professional Practice in the Engineering curriculum is the incorporation of outside-sponsored student team projects. We have described one such model for these projects, and some of the difficulties in establishing a professional practice program. In addition, we have outlined an example of a more comprehensive Strategic Corporate Alliance that will help strengthen overall corporate support and further enhance professional practice in the curriculum.

Reference

¹ Susannah Howe and Jessica Wilbarger, Smith College, “2005 National Survey of Engineering Capstone Design Courses”, 2006 ASEE Annual Conference and Exposition.

Practical Lecture, Research, and Projects Based Engineering Education

**Jeffrey Ashworth, Ph.D., and Samer Shaghoury
Embry-Riddle Aeronautical University, Prescott Campus**

Abstract

A lecture, research, and projects based course has stimulated student interest in aircraft aerodynamics, performance, and static stability and overwhelmingly enhanced preparation for the practical aircraft conceptual/preliminary capstone design course. This unique elective course titled "Aircraft Flight Mechanics and Performance" uses learning methods reinforced by application techniques to analyze actual aircraft performance. Semester lectures cover three topics in nearly equal segments: practical aerodynamics, total aircraft performance, and static stability derivatives. These lectures contain references from many authors/texts for researching and understanding various techniques to analyze aircraft characteristics in the three areas. Students apply the various techniques in five assigned projects. Each project is documented in a written technical report and the final project includes a presentation of the overall results. An outstanding motivational aspect of the current course is the ability to analyze the student data and compare to published results of existing aircraft. This paper demonstrates how team learning and applied research techniques for analyzing the performance and stability of actual aircraft can assist and motivate students in any aircraft project. The described approach could easily be successfully applied to projects in any engineering discipline.

Introduction

Many airplane design capstone courses in aeronautical and aerospace engineering programs in universities around the globe have adopted a purely theoretical approach to teaching design. This approach is characterized by assigning senior design students the task of re-designing a part of an existing airplane. Often this re-design requires utilizing a computer code or routine the students may or may not have written. The students may not be completely familiar with the boundary conditions or restrictive assumptions of the given routine. While this approach may mirror the tasking assigned a beginning engineer in industry, it seems to limit the scope of expertise and the effective areas for notable performance in an initial job. Industry representatives often express a preference for new graduates to possess a broader knowledge in the fundamentals rather than an in-depth background that could be achieved in a later graduate program. The Preliminary Airplane Design (AE 420) course at the Embry-Riddle Aeronautical University (ERAU), Prescott campus tasks the senior student groups to design an entire airplane given only performance requirements documents. The students must have design expertise in all areas including aerodynamics, propulsion, stability/control, weight/balance, structures, landing gear, and computer aided drawing/design techniques. If practical courses providing the fundamentals in these areas are not included in the pre-requisites, the students will enter the design sequence without the necessary basic skills to accomplish an entire aircraft design following basic established design methodology. After years of observing students struggle with the basics in the design course, it is apparent a course like the Aircraft Flight Mechanics and Performance (AE 395N) course is essential to develop a practical background before students entered the design sequence.

Course Overview and Motivation

The AE 395N course has been taught at ERAU in the fall semester for the last two years. This course was developed to provide practical instruction in three areas found to be necessary for design but not sufficiently covered in other courses. These three areas include: aerodynamics, performance, and aircraft static stability. The course is based on lectures, research, and projects to verify results. The projects are assigned during the semester to utilize each of these areas for problem solution and method verification. The research for each assignment usually reveals multiple methods advocated by different authors. The student group of two will research and evaluate each method, analyze the resulting data from each, and make a solution decision based on critical thinking and analysis. The results are documented in five reports and a final presentation. The first project is an individual effort to plot published airfoil lift and drag curves for a selected existing aircraft. The four remaining projects utilize groups to promote team dynamics and analyze/plot data for the aircraft. The second project expands the airfoil data into wing data including high-lift-devices. The third project completes the aerodynamic phase by including the fuselage and empennage. The fourth project evaluates performance of the entire aircraft and plots total thrust and drag data. Project five is the final project and includes thrust, drag, excess power, and flight envelope plots and also calculates take-off, range, endurance, and turning performance data.

Students learn more, quicker, and retain knowledge better when the subject is of high interest. Theoretical concepts in early undergraduate courses are sometimes difficult to comprehend when a student may not see a direct application of the material to a practical system. Early engineering students often have this problem with the required mathematics and physics due to few direct applications of the material until the upper-level courses in their engineering discipline. Engineering students enter their discipline because of a desire for knowledge in a certain area. Aerospace engineering students in the airplane track pursue this discipline because of their interest in airplanes. The first time the AE 395N course was taught, the solution techniques were applied to generic wings and aircraft with given dimensional and performance parameters. Feedback from students both currently in or already completed the design (AE 420) course indicate the AE 395N course was extremely helpful in preparing the students for all practical applications to design. However, it could always be improved. Therefore, the second version of AE 395N was modified to incorporate existing aircraft for the solutions and analysis. The student motivation for analyzing performance characteristics of these existing aircraft increased dramatically. The learning objectives were more thoroughly accomplished and the preparation for using the same research and analysis techniques in the follow-on design course was considered outstanding by the students.

Comparison and Results

In the first part of the AE 395N course, the course schedule is outlined and references for all research material are given. The students are also given a list of airplane dimensions and performance parameters for five different airplanes ranging from single engine general aviation to large jumbo jet. The students select the aircraft they wish to analyze and select partners for the group projects. The students use given aircraft dimensions and parameters to analyze the performance of the selected aircraft through a sequence of projects. Each project is assessed and corrected if necessary to ensure proper data for the following project. In assessing student

performance for the course, all student data was realistic and encouraging when compared to actual aircraft data.

The sample student data presented here is for the T-38 Talon aircraft. This aircraft was selected due to the availability of actual aerodynamic and performance data plots for comparison. The student data are shown here in the course sequence as it was determined with descriptions of the analysis techniques and accompanying data plots. The calculated aerodynamics and performance characteristics, denoted as “AE395N” in the plots, were found using methods defined by Mattingly¹, Raymer², Yechout³, and Nicolai⁴. The majority of the geometrical and propulsion data on the T-38 are listed in Yechout³. All analysis was accomplished assuming military thrust (i.e., full throttle, no afterburner). Some geometric and aircraft configuration data were approximated from three-view drawings of the aircraft. The calculated solutions are shown as dashed blue lines and the published T-38 data are shown as solid red lines.

The course initial solution project is to convert two-dimensional (2D) airfoil data to three-dimensional (3D) wing data. The airfoil data is taken from the experimental results published by Abbot and von Doenhoff⁵. The results of this conversion are shown in Figure 1.

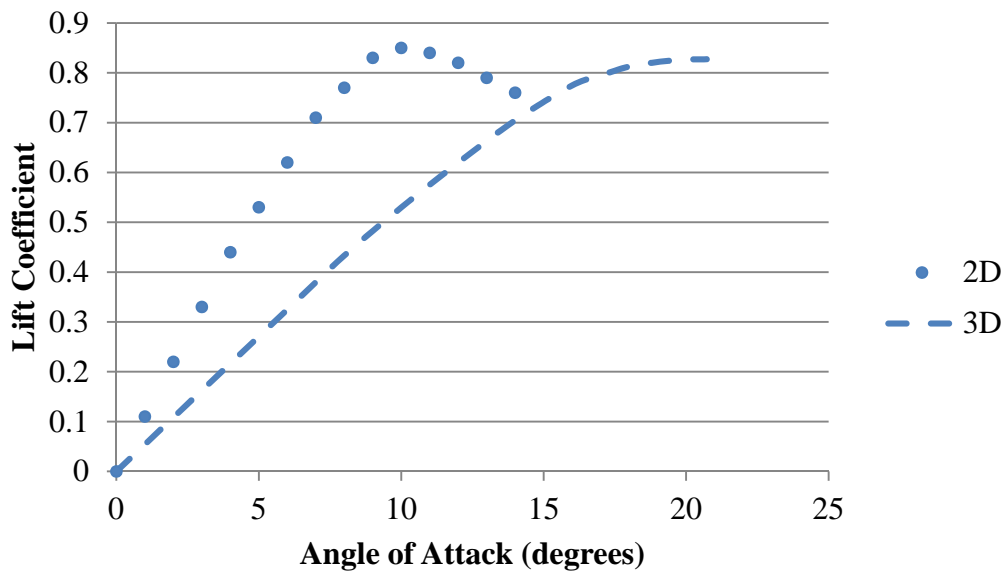

Figure 1: 2D and 3D Lift Data

The 2D to 3D conversion data follows general trends for aerodynamics. As expected, the maximum lift coefficient decreases and the stall angle of attack increases⁴. A similar analysis was accomplished on the horizontal tail of the aircraft.

The method of analyzing 3-D lifting surfaces as well as predicting stall characteristics uses both empirical relations and theoretical equations with corrections (e.g., for compressibility, wingtip vortices, etc.)⁴. After approximating the aircraft geometry (e.g., fuselage shape and location of lifting-surfaces), the overall aircraft lift curve can be determined. The Air Force Stability and Control DATCOM⁸ was used to estimate the fuselage contribution to the lift curve. The published lift curve of the entire T-38 aircraft is shown in Figure 2 plotted with the calculated value.

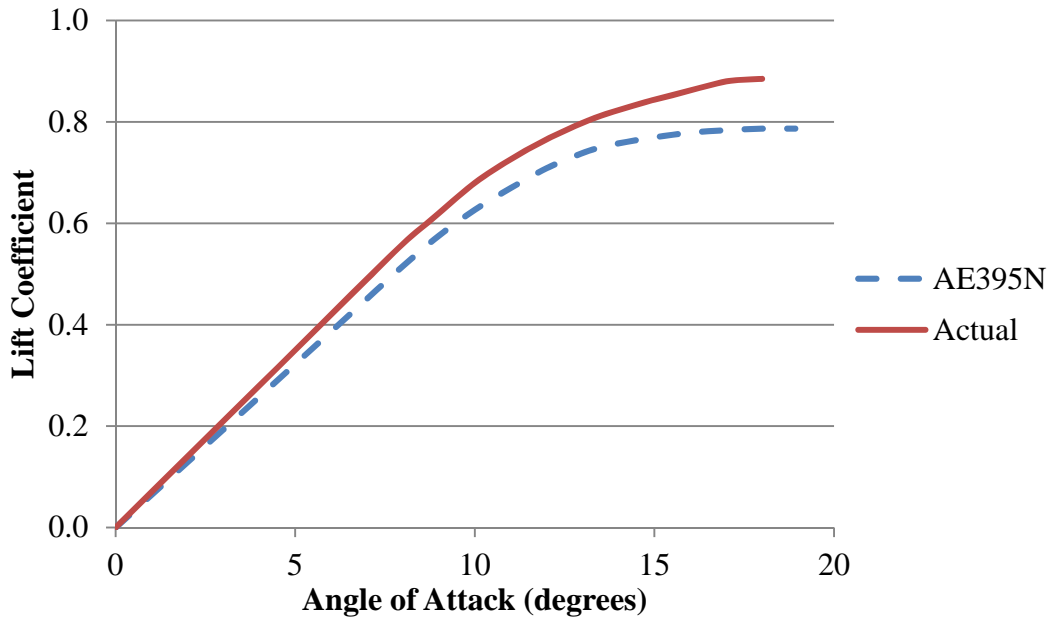

Figure 2: Aircraft Lift Curve

Figure 2 shows reasonable agreement between calculated and published data in aircraft lift-curve slope and stall characteristics. The calculations were accomplished using methods described in Raymer⁴ and the DATCOM⁸.

The aircraft lift curves with flaps deflected to 45 degrees are shown in Figure 3. The calculated values of lift-curve slope and maximum lift coefficient were obtained from methods outlined in Nicolai⁶.

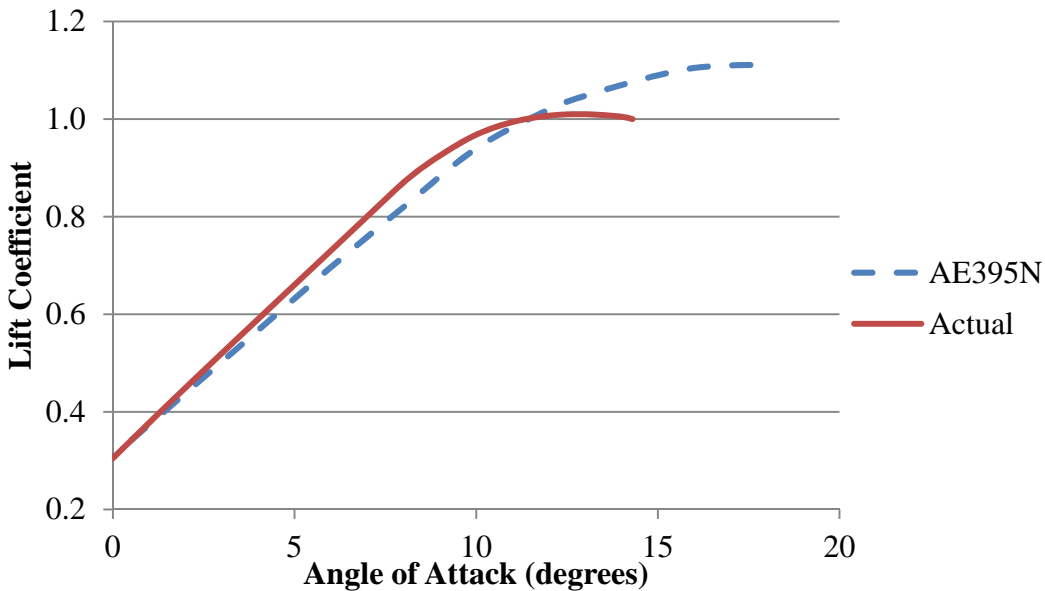

Figure 3: Aircraft Lift Curve with 45 degree Flap Deflection

The calculated lift-curve slope and zero-lift angle of attack show good agreement with the published data. The maximum lift coefficient and stall angle of attack are not coincident with the published due to the lack of accurate dimensions on the flap geometry in the published data.

The performance parameters of the aircraft were calculated utilizing values from the lift curves. The thrust required or drag was calculated for steady, level, unaccelerated flight. The thrust available was calculated using procedures found in Mattingly¹. Parasite, induced, and wave drag were estimated utilizing a drag build-up method². Since exact aircraft cross-sectional and wetted area dimensions were not available, the estimated parasite drag of the entire aircraft was based on assumptions that added error to the data. Using the installed military thrust of the T-38 engines at sea level, the effects of altitude change and Mach number were estimated using empirical relations based on engine performance analysis¹. The results of the drag and thrust analysis at sea level and 20,000 feet are shown in Figure 4.

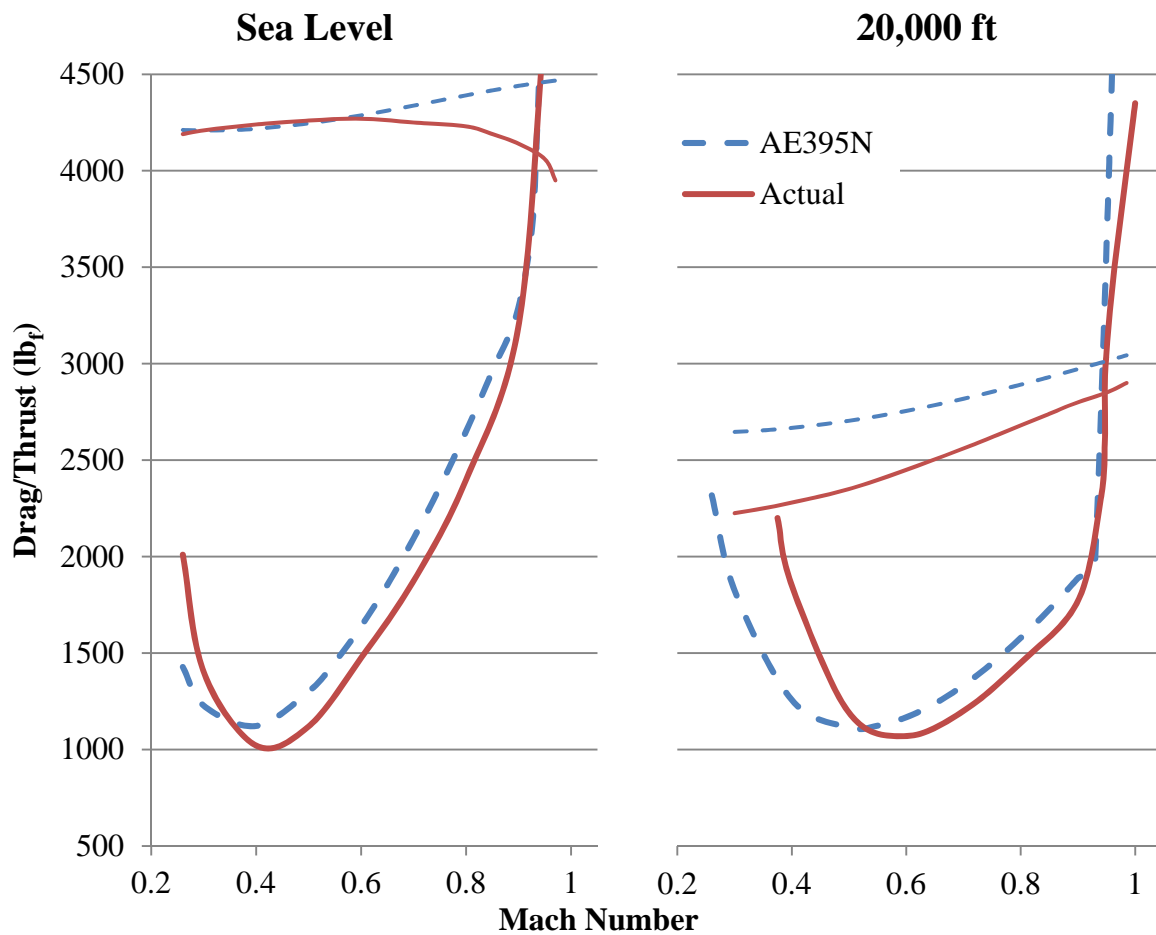

Figure 4: Thrust Available and Thrust Required

In Figure 4, the thinner lines represent the thrust available, and the thicker lines represent the thrust required. With the exception of lower Mach numbers at 20,000 feet, the thrust required analysis closely matched the actual drag behavior of the T-38. The calculated empirical relations were based on engine operation close to ideal operating conditions. This assumption caused variance in thrust available when flight conditions differed from ideal operating conditions.

The specific excess power was obtained from the thrust and drag analysis. These specific excess power curves at different altitudes are plotted versus Mach number and are shown in Figure 5.

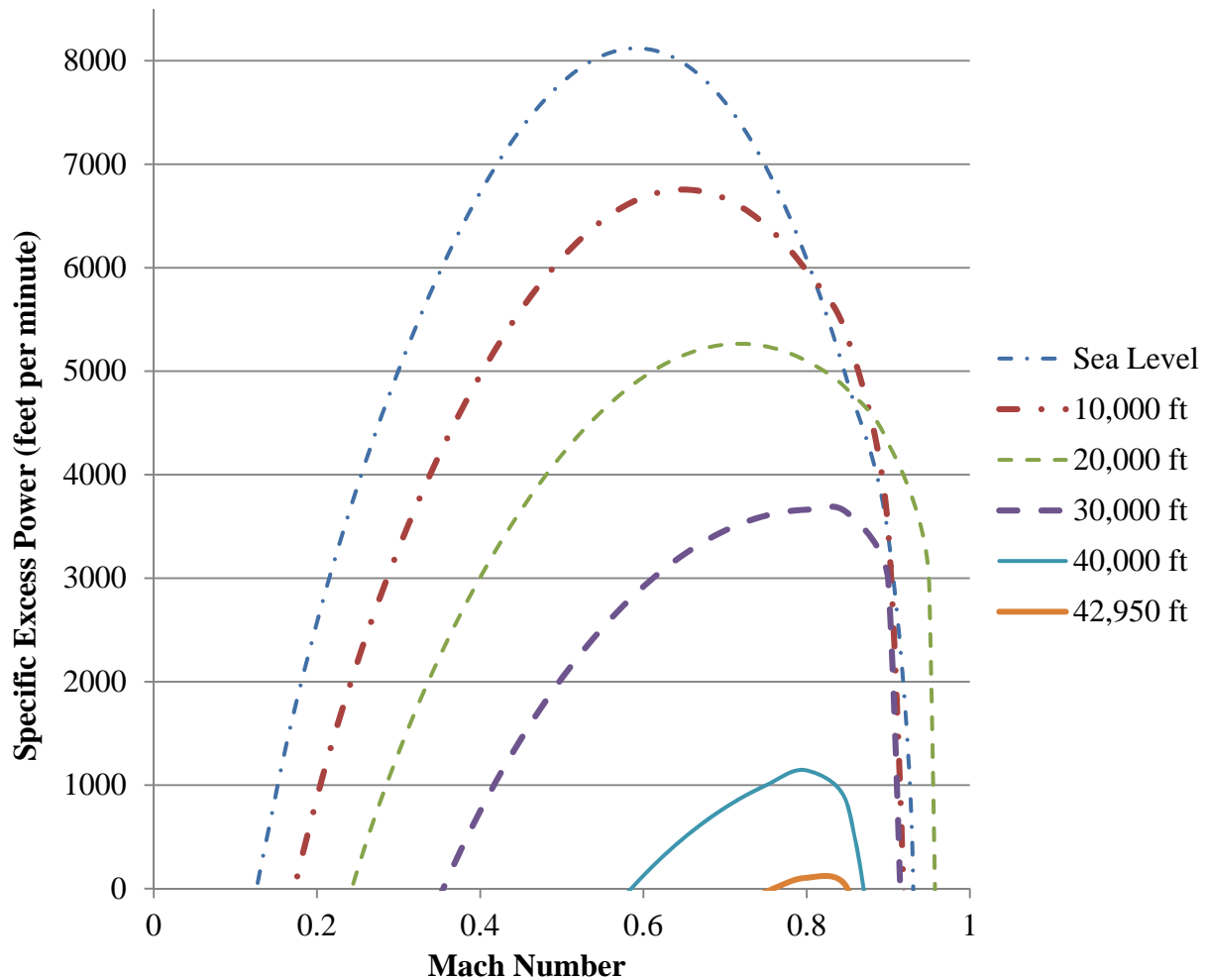

Figure 5: Specific Excess Power

Figure 5 shows the calculated specific excess power from sea level up to the service ceiling at 42,950 feet (i.e., when specific excess power equals 100 feet per minute).

A velocity versus load factor (V-n) diagram was constructed using the calculated stall velocity, given load limits⁵, and the calculated dynamic pressure (q) limit. At sea level, the q limit is defined as the dynamic pressure corresponding to the maximum level velocity where thrust available equals the thrust required. This value of dynamic pressure is used at other altitudes and densities to solve for the corresponding Mach number. The data indicates a similar method was used to obtain the q limit of the published data. The calculated T-38 V-n diagrams for sea level and 15,000 feet are shown in Figure 6.

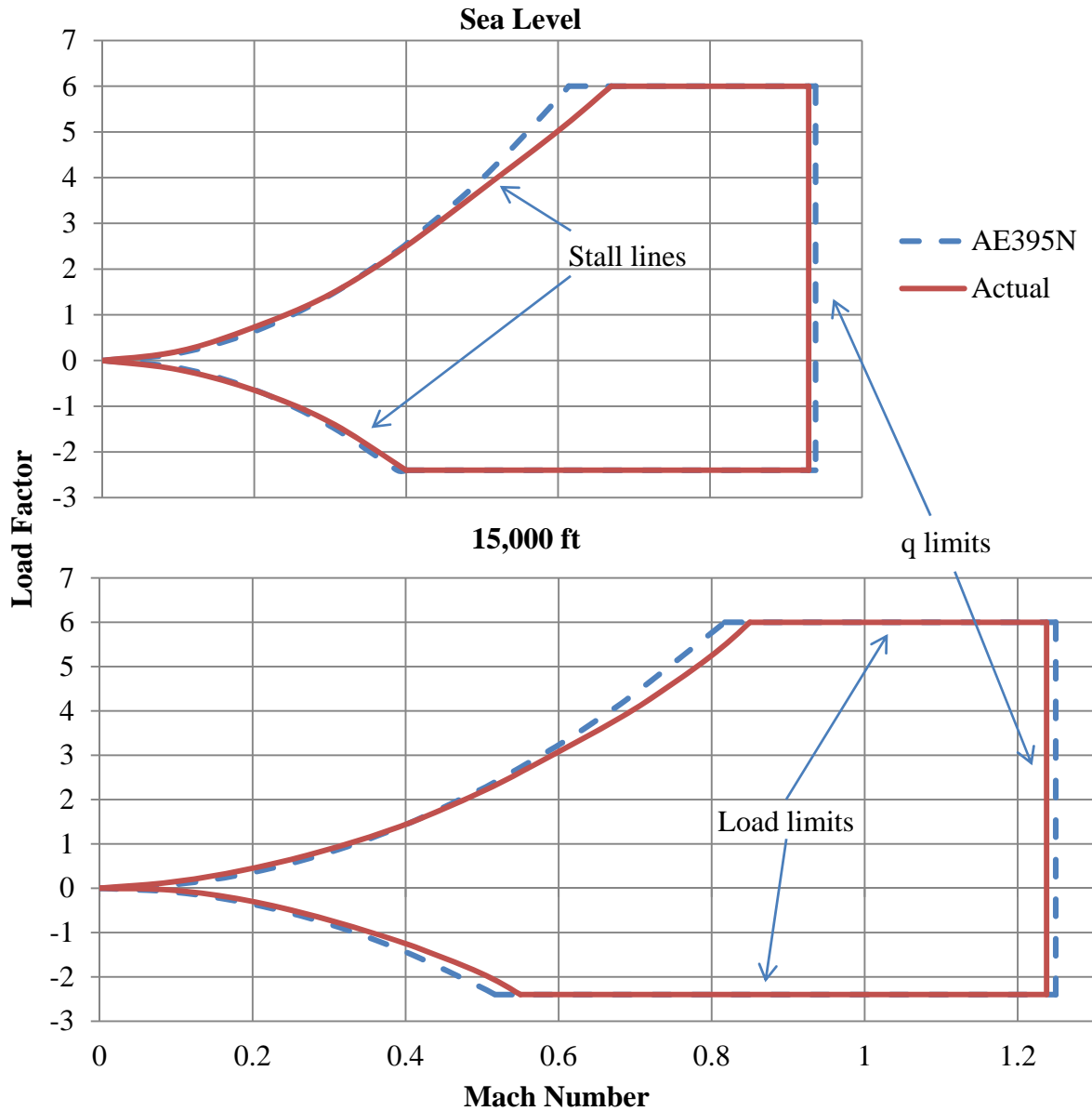

Figure 6: V-n Diagrams

Figure 6 demonstrates nearly identical stall and q limit lines when the calculated and published data are plotted. Slight deviances from the published V-n diagram occur on the stall lines at higher Mach numbers.

The T-38 was one of the aircraft analyzed in the AE395N course to obtain general aircraft performance characteristics. Lift curves, thrust available and thrust required curves, and V-n diagrams were used for the purpose of comparison. This course methodology employed techniques from multiple authors, data from published sources, and comparisons to actual flight test data to verify the course objectives and student outcomes.

Conclusions and Recommendations

Predicting actual full-scale aircraft performance throughout a variety of flight conditions using empirical techniques is very difficult. Many assumptions are made throughout the solution process and every aircraft variable affects all aspects of the overall performance. However, the student data plots show accurate performance trends and often very similar numerical results. The student T-38 solutions included here show good comparison to the published T-38 data verifying the student techniques and performance analysis methods. The aerodynamics and follow-on performance reflect valid techniques but seem limited by the dimensions and performance parameters given in the initial aircraft description. Some aircraft parameters were not available in published form before the course began so these were measured from aircraft drawings or assumed from similar aircraft. These assumptions in initial conditions and somewhat limited application to full-scale aircraft contributed to most of the differences in the data plots. However, the close agreement is very encouraging to the student groups and stimulates interest and understanding of the course material and follow-on design course.

In order to give the students the best possible chance at predicting aircraft performance, the instructor will contact aircraft companies for more specific dimensions, performance parameters, and data plots for comparison. More accurate industry-provided initial dimensions and parameters will improve student results and comparisons. Also, data for more aircraft will be requested so the students will have expanded variety in the aircraft selection and be able to analyze the type of aircraft they want to know more about.

This teaching method/technique is applicable to any engineering discipline. Nearly any engineering project can use basic techniques to analyze the performance of an existing system. In air-breathing propulsion class, the students could analyze an existing engine. In machine technology class, the students could use basic techniques to analyze the performance of an existing system. Often, in the current high speed environment, our students are assumed to be completely comfortable with the basics so course time is spent teaching favorite unique techniques or processes. Students may not fully understand these techniques nor really ever have the opportunity to use them. If students have the basic knowledge required by their discipline, there is no problem adapting to whatever specific environment encountered in initial job tasks as a beginning engineer. If new graduates have specifics without the basics, it will be difficult to adapt unless the initial tasks are exactly the same as their educational environment. So, to motivate our students and give them the best background possible, teach the basics through team/projects based delivery and comparison to real world systems.

Bibliography

1. Mattingly, J. D., Heiser, W. H., & Pratt, D. T. (2002). *Aircraft Engine Design, 2nd ed.* Reston, VA: American Institute of Aeronautics and Astronautics, Inc.
2. Raymer, D. P. (1999). *Aircraft Design: A Conceptual Approach* (3rd ed.). Reston, VA: American Institute of Aeronautics and Astronautics.
3. Yechout, T. R. (2003). *Introduction to Aircraft Flight Mechanics.* Reston, VA, USA: AIAA.
4. Nicolai, L. M., & Carichner, G. E. (2010). *Fundamentals of Aircraft and Airship Design: Volume 1–Aircraft Design.* Reston, Virginia, USA: American Institute of Aeronautics and Astronautics.

5. Abbot, I. H., & Von Doenhoff, A. E. (1959). *Theory of Wing Sections: Including a Summary of Airfoil Data*. Mineola, NY: Dover Publications, Inc.
6. Williams, J. E., & Vukelich, S. R. (1979). *Airforce Stability and Control DATCOM*. United States Air Force.

A Novel Approach to Expose Students to Global Issues in Civil Engineering and Construction Engineering Management

**Antonella Sciortino, Lisa Star, and Tesfai Goitom
Department of Civil Engineering and Construction Engineering
Management California State University, Long Beach.**

Abstract

The availability of new technologies has resulted in great achievements in the civil engineering and construction engineering management fields worldwide. Young engineers should be equipped with the necessary knowledge to perform their jobs in any region of the world, and they should be able to understand the unique cultural and societal environment in which their designs are implemented. Engineering courses need to provide students with the global engineering perspective that will prove beneficial for their careers and this should be done at the early stages of the engineering curriculum. This study proposes a novel approach to expose civil engineering and construction engineering management students to current global issues in engineering and construction practices. An additional goal is the improvement of retention rates by increasing students' interest in the engineering field. The proposed approach consists of encouraging mentoring and collaboration between graduate students enrolled in a research course and freshmen/sophomore students enrolled in an introductory engineering course. The two groups work in teams to prepare a term paper and a presentation that focuses on a comparative assessment between two similar engineering projects, one in the United States and the other in a foreign country with an emphasis on engineering and construction practices and societal, economical and environmental issues. The challenges that we faced during the implementation of the plan and the proposed improvements to the courses are presented.

Introduction and Background

In today's rapidly changing society, the new generation of engineers and construction managers must not only be equipped with advanced technical knowledge but also be able to understand the impact that engineering solutions have on society, environment and economics in a global perspective. Engineering problems are similar everywhere in the world and they are solved according to the physical and mathematical principles at the foundation of engineering science. However, each solution should reflect the unique cultural and societal environment in which it is implemented.

Ideally, young engineers should be exposed to the global issues involved in the engineering profession while they are still in school. Unfortunately, due to the high number of units necessary for graduation compared to other programs, many engineering programs don't have the flexibility to accommodate additional courses that would provide students with the global engineering perspective necessary to advance their careers. Furthermore, financial constraints may prevent many engineering students from acquiring a broad international experience.

Freshman engineering introductory courses represent an opportunity to fill the gap in this area. In such courses students should learn to see engineering as a profession that, by providing solutions to every-day problems, has implications for individuals as well as society as a whole. Acquiring skills at an early stage will not only increase student interest in pursuing engineering careers, but it will help them to understand and implement innovative design solutions in more advanced courses and it will promote lifelong learning. Freshmen introductory courses, which have been developed at four-year institutions nationwide, familiarize students with the engineering field and improve retention rates¹. Many of them include hands-on project activities coupled with lectures aimed at the development of problem solving skills and introduction to available resources^{1,2,3,4,5}. However, few provide a sufficient exposure to global engineering issues. The importance of this component in engineering education is emphasized by ABET in the list of Student Outcomes included in the 2013-14 General Criteria Section 3⁶. Specifically, Outcome *h* states that engineering programs should provide student with "the broad education necessary to understand the impact of engineering solutions in a global, economic, environmental, and societal context".

While it is beneficial to expose students to engineering as soon as they enter the program, many freshman students often do not possess the necessary background to perform research on their own and to fully analyze the technical aspects of engineering projects. Faculty support is indispensable to guarantee a successful outcome, but peer mentoring could also be an effective strategy to engage students. Peer mentoring programs that employ junior or senior undergraduate students as mentors for freshman/sophomore students, either in freshman courses or in extra-curricular activities, have been extensively implemented to improve recruitment and retention in the Science, Mathematics, Technologies and Engineering (STEM) disciplines^{7,8,9,10} to encourage women and minority students to pursue a career in engineering^{11,12} and to support undergraduate students working on research and project-based activities^{13,14}. These programs may facilitate the transition from high school to higher education, encourage exchange of experiences, and raise the enthusiasm and interest in engineering. However, the level of technical knowledge of potential mentors is limited and a full understanding of the global issues involved in the engineering profession cannot be expected. Graduate students may be more suitable as mentors to undergraduate freshman/sophomores students in engineering introductory courses to work on projects designed to increase student awareness of the global impact of engineering solutions and they could also provide counseling on academic life. Graduate students are typically young professionals who have successfully overcome the obstacles encountered by most students during their academic career, have already acquired enough design experience in senior and graduate courses, and have been exposed to the day-to-day challenges of the engineering profession through their work experience in engineering companies. Many graduate students are also international students who can provide an invaluable foreign perspective on the engineering profession. Yet, because of their student status, they are still considered peers by the undergraduates, thus removing the barriers that usually prevent a more effective collaboration between undergraduate students and faculty members or professionals from industry. Interaction between graduate and undergraduate students through mentoring programs has been implemented at the University of Texas at Austin, and at the University of Colorado at Boulder^{15,16}. In both programs undergraduate students were paired with graduate students on research projects for the purpose of improving retention of women and minority students in

engineering to provide undergraduate students with the opportunity to gain research and work experience.

In this paper we present experiences of a recent program at California State University, Long Beach (CSULB) aimed at exposing civil engineering and construction engineering management students to current global issues in engineering and construction practices through mentoring and collaboration between graduate and freshmen/sophomore students.

The Proposed Plan

The College of Engineering at CSULB has developed a series of three one-semester-unit introductory courses to provide students with information regarding the engineering career, the resources available on campus and the basic tools to successfully progress toward their degree. The courses have received GE certification by the University in Category E: "Lifelong learning and Self-development". Two of the courses, ENGR 101 and ENGR 102, are offered at the college level, the third course is offered by each department and is discipline specific.

The discipline specific course offered by the Civil Engineering and Construction Engineering Management Department (CECEM) is CE 101 "Introduction to Civil Engineering and Construction Engineering Management". This is a mandatory course for all civil engineering and construction engineering management students, including transfer students. About 90 to 100 students enroll in this course per semester. The course introduces students to the civil and construction engineering fields. It includes curriculum information and requirements, career paths, and engineering ethics. As part of the requirements for the course in its original format, students worked in teams on a term paper and a presentation that focused on a major engineering project. The course satisfies ABET Student Outcomes *h* – Achievement of the broad education necessary to understand the impact of engineering solutions in a global, economic, environmental, and societal context -, Outcome *i* - Recognition of the need for, and the ability to engage in life-long learning -, and Outcome *j* - Knowledge of contemporary issues.

Although the selection of a foreign project as topic of the paper provides the students with some insights on different approaches to engineering problems and solutions around the world, in the past, the global exposure has not been systematically implemented throughout the course.

At the graduate level, the Civil Engineering curriculum requires students to take the CE 696 "Research Methods" class. The class focuses on the development of a research proposal to address a specific engineering problem in the area of interest of each student. The proposal is the basis for the project that the students will work on, either in a subsequent class, CE 697 "Direct Studies" or as part of their thesis. The topics selected for the CE 696 proposal often do not include a global engineering component, but the Civil Engineering Masters program serves a large number of international students who represent a valuable resource in term of cultural experience and diversity. About 20-25 students per semester enroll in this course.

During the spring of 2012 the course content of both CE 101 and CE 696 was modified to provide both groups of students more exposure to current global issues in engineering and

construction practices. The modifications were designed by the authors of this paper, who are also the instructors of CE 101 and CE 696. The proposed modifications were as follows:

Modifications Proposed to the CE 101 Course

Term paper and Presentation Content

As part of the requirement for the CE 101 class, students work in teams to submit a term paper and present it to the class as an oral presentation at the end of the semester. The term paper focuses on two projects within a specific civil engineering area. One project has to be in the U.S. and the other in a foreign country. The two projects are selected because there is some similarity between the problems to be addressed. Students are required to analyze the two projects and compare the engineering design and construction practices, and highlight the impact of local environmental, cultural, and societal issues on those solutions. In some cases projects also included an historical component to illustrate how design solutions and technology have developed over time.

Some examples of term paper topics include:

- Skyscraper Design: The World Trade Center Twin Towers, NYC, and the Petronas Towers, Malaysia.
- Bridge Design: The Golden Gate Bridge and the Millau Viaduct in France
- Tunnel Design: The Boston Big Dig and the Channel Tunnel between France and England.
- Dam Design: The Hoover Dam and the Three Gorges Dam in China.
- Water Distribution Systems Design - Differences and similarities in the approach to design water distribution systems in history: The Los Angeles Aqueduct and the Roman aqueducts in Europe.
- Water Pollution. Managing and solving water pollution problems: The Orange County "Toilet to Tap" project and the London Sewers project.

Information should be provided on the purpose of the two projects, their geographical locations, the starting and ending time of construction, the names of the design engineers and the construction company. The main body of the paper and the presentation has to include the following sections:

1. Technical discussion: Students need to describe the main component of the design for the two projects including, if applicable, the structural design, the foundation design, and the design of the components of the projects and highlight similarity and unique features of each design.
2. Discussion on Global Issues: Students need to compare the two projects and analyze both the impact of local cultural, societal, and environmental issues on the specific design solutions adopted for the project in both countries (e.g., availability of materials, different design standards, and environmental impact regulations) and the impact the projects had on local population, environment, and economy. If the project also has an historical component, students are asked to highlight how the design techniques evolved over time and to discuss the impact of technology development on the design.
3. Construction Process: Students need to describe the construction work for each project and compare and contrast the construction processes in the two countries.

Each student team is mentored by two graduate students from CE 696, possibly one international student and one domestic student. Student mentors are selected to match the projects with their expertise. For example undergraduate students working on a project that focuses on skyscraper design are mentored by graduate students specializing in structures. The international student provides mentoring on the foreign project and on the issues that engineers in the foreign country faced and the solutions they proposed. The domestic student provides mentoring on the same topics for the project in the United States. Specifically, graduate students guide the students during the collection and selection of pertinent literature, provide their expertise on the design component of the two projects, and help the undergraduate students to evaluate the global issues related to their projects. In addition, graduate students could provide information to the undergraduate students on non-technical issues such as presentation or writing skills, work-life issues, career or graduate school information.

Lectures

Two lectures are devoted to global issues in civil engineering and construction engineering management. One lecture is devoted to the discussion of the ASCE Report Card on American Infrastructures¹⁷ and the other focuses on the fourteen Grand Challenges for Engineering identified by the National Academy of Engineers¹⁸.

Presentations

In addition to the project presentations by the undergraduate student teams, a lecture is devoted to presentations by two graduate student mentors. The students present their research topic and emphasize the global issues related to their research. The selection is made based on the research topic and its global content.

Assignments

One homework assignment, which in the original format of the course involved a library search to familiarize students with engineering databases and professional journals, was modified in collaboration with the engineering librarian to focus on the specific topic of the term paper. Students are required to perform a literature search and to provide four citations pertinent to the domestic project and four citations pertinent to the international project. At least two of the references should be books, encyclopedia articles, scholarly journals, magazines or newspapers, and two could be authoritative sites from the Internet. Graduate student mentors provide guidance for the selection of appropriate references.

Modifications Proposed to the CE 696 Course

Research Proposal Content

When performing background research for the international project, students are expected to include at least one citation involving an international journal or research group. Students are encouraged to discuss the specific engineering problem they selected for the research proposal from a global perspective. While this could be easily done for an applied research project, it might be a challenge for students who select a more theoretical topic. In this case they are required to identify possible applications of the research results and to discuss their global implications.

Assignments

As a requirement for the class all students serve as mentors for CE 101 student teams as explained in the section above. Graduate students receive 10% of their grade in CE 696 from mentoring assignments.

Presentations

Two students, an “international” and a “domestic” student per semester, are selected to present their research proposals to the CE 101 class as explained in the previous section.

Project Implementation and Preliminary Observations

To evaluate the effectiveness of the proposed changes we decided to implement them in the following step-by-steps fashion:

- Modify and implement selected components of the courses
- Perform an informal assessment to highlight the strengths and weaknesses of the plan
- Perform a formal assessment to evaluate student outcomes
- Develop strategies to improve the student performance
- Implement the remaining proposed modifications

During the Spring 2012 and Fall 2012 semesters we implemented some of the proposed modifications in all the sections of the CE 101 course. We changed the content and format of the term paper and presentations as described and we added the mentorship component, we modified the library assignment, and we introduced two lectures on global issues. At the beginning of the semester the CE 101 instructors divided the students in teams of five to six students and assigned them their project topics. In collaboration with the CE 696 instructor, each team was paired with at least two graduate students. Although we tried to assign one international and one domestic student per team this was not always possible, due to the limited numbers of international students enrolled in the graduate course. An introductory meeting was added to the schedule to give a chance for the CE 101 and CE 696 groups to meet in person in a formal setting. CE 696 students were graded on their attendance at the meeting.

We did not run a formal survey to collect students' feedback, but our own observations from both classes revealed that the major challenge in the proposed plan was the implementation of the mentorship component. Specifically we observed the following:

- **Scheduling conflicts:** Many of our students at both graduate and undergraduate level hold jobs or internship positions in engineering companies and local agencies and it might be difficult for many of them to find a common time for meeting and discuss the project. Furthermore, our graduate courses are all scheduled in the evening (starting at 6:00 pm) while most of the freshman courses are scheduled in the morning or early afternoon. Availability of graduate students is of major concern because in addition to work, they might also have family obligations.
- **High number of mentees per mentor:** Due to the high enrollment in the CE 101 course and the relatively low number of graduate students available in CE 696, each pair of graduate students ended up mentoring three teams for a total of 18-20 undergraduate students. This is a very high mentor-to-mentee ratio, which might decrease the effectiveness of the mentoring experience and make scheduling meetings even more difficult.

- Lack of a structured mentoring activity: Because we anticipated problems related to scheduling a meeting time, we decided to leave students the flexibility of scheduling their meetings at times that were more convenient for all team members. We also decided not to make meetings in person mandatory, allowing communication through e-mails and by phone, and we did not require a written record of student progress except for the library assignment related to the literature review that was due toward the middle of the semester.
- Lack of clear guidelines for the project: At the beginning of the semester the CE 101 instructors distributed a detailed description of the project and presentation requirements to their class. However a similar document was not provided to the graduate students. Our assumption was that the undergraduate students would communicate the requirements to their mentors, but this might not always have been the case.
- Lack of interest in the activities and unclear mentorship guidelines: Undergraduate students might not appreciate the importance of receiving guidance and assistance from a more experienced peer. Some graduate students might not be fully aware of what mentorship involves and the benefits that mentorship will provide to their professional development beyond the credit they will receive in the class for participating.

Similar challenges were reported by Attarzadeh et al.¹⁹ while implementing a mentorship program at the University of Houston where seniors were recruited to mentor students in lower-division laboratory courses. The authors proposed a set of strategies to improve the effectiveness of the program.

Proposed Strategies

Below are some of the strategies that will be implemented in our mentorship program based on our observations and suggestions by Attarzadeh et al.¹⁹.

- Resolve scheduling conflicts: We will schedule two mandatory in-person meetings per the semester during class time. To guarantee the availability of the mentors, two lectures in CE 696 will be scheduled so that mentors will have the opportunity to meet face-to-face with their mentees and provide guidance on the project. Unfortunately the CE 101 and the CE 696 classes are currently scheduled at different times during the day and it might therefore not be possible to have all the undergraduate students attending. We will require that at least one student per team participates in these meetings. Furthermore, we will require two more mandatory meetings outside the scheduled class time for both mentors and mentees to meet in person.
- Decrease the ratio of mentor-to-mentee: We will reduce the numbers of team members and we will pair each team with one graduate student based on the focus of the project and the expertise of the mentor to reduce the mentor-to-mentee ratio to one mentor per 5-6 undergraduate students.
- Provide structure to the mentoring activity: As suggested by Attarzadeh et al.¹⁹, in addition to assigning mandatory in-person meetings we will encourage students to communicate by email and by establishing discussion sessions using the class websites, and we will assign a portion of the credit that undergraduate students earn for the paper and presentation to attending the mentoring meetings. Furthermore, we will add an assignment in both classes for which students will earn credit toward their final grade. Prior to each meeting, the undergraduate students will be asked to report on the progress of their paper and presentation

to their mentor. The graduate student mentor will be responsible for reviewing and signing the report, to provide feedback and guidance for the next step of the project, and to prepare his or her own progress report. The undergraduate reports will be turned in to the CE 101 instructor while the graduate student reports will be turned in to the CE 696 instructors for credit on specified due dates.

- Provide clear guidelines for the project: During the introductory meeting, the instructors of the CE 101 course will provide both graduate and undergraduate students with the project guidelines and will discuss the scope of the project, the requirements, and the roles of mentors and mentee.
- Increase student interest in the mentorship activity and train mentors: Attarzadeh et al.²² highlighted the importance of training mentors in non-technical skills to increase their ability to engage students who might not be interested in either mentoring or in being mentored and to emphasize the benefit that mentees can gain from the experience. To accomplish this, both instructors in CE 101 and CE 696 will devote time in their lectures to explain the scope of the mentorship activity, the role of mentors and the benefit that both mentors and mentees will gain professionally from participating.

Finally we will develop a formal survey to assess the effectiveness of the proposed strategies and we will define specific student outcomes and assessment tools in both classes to quantitatively measure student performance.

Acknowledgements

The authors would like to acknowledge the CSULB "Incentive Award for Globalization Instruction" program for providing funding for this study.

Bibliography

1. Knight, D.W., L.E. Carlson, and J.F. Sullivan, 2007. "Improving Engineering Student Retention Through Hands-on, Team-Based, First-Year Design Projects". *Proceedings of the ASEE 31st International Conference on Research in Engineering Education*, Honolulu, HI.
2. Knox, D.E., and B. C. Baltzis, 2002. "Introduction to Chemical Engineering - A New Course for Freshman Students". *Proceedings of the 2002 American Society of Engineering Education Annual Conference & Exposition*.
3. Ferrara, I., and A. Vavreck, 2007. "Analysis of the Retention of Students and Possible Recruitment Into Technology in a Common First-Year Course for Engineering and Engineering technology students". *Proceedings of the 2007 American Society of Engineering Education Annual Conference & Exposition*.
4. Shaw-Courter, S., S.B. Millar, and L. Lyons, 1998. "From the Students' Point of View: Experiences in a Freshman Engineering Design Course". *Journal of Engineering Education* v 87, n 3, p 283-287
5. Hoit, M., and M. Ohland, 1998. "The Impact of a Discipline-Based Introduction to Engineering Course on Improving Retention". *Journal of Engineering Education* v 87, n 1, p 79-85.
6. "Criteria for Accrediting Engineering Programs, 2013-14" Accreditation Board for Engineering and Technology, 2012. <http://www.abet.org>
7. Budny, D., and C.A. Paul, 2004. "Integrating Peer Mentoring Into the Freshman Curriculum". *Proceedings of the 34th ASEE/IEEE Frontiers in Education Conference* Vol.3, pp. S3F-29-S3F-36.
8. Gattis, C. B. Hill, and A. Lachowsky, 2007. "A Successful Engineering Peer mentoring program". *Proceedings of the 2007 American Society of Engineering Education Annual Conference & Exposition*.

9. Bates, R., D. Nykanen, M. Hart, and R. Mezbahur, 2010. "Undergraduate Engineers and Interdisciplinary Peer-Mentoring Groups". *Proceedings of the 2010 American Society of Engineering Education Annual Conference & Exposition*.
10. Fitch, D., K.J. Shryock, and D.C. Lagourdas, 2012. "Creating a Support Network for Students Through a Student-Led Mentoring program". *Proceedings of the 2012 American Society of Engineering Education Annual Conference & Exposition*.
11. Farver, D., and C. Gattis, 2006. "Development and Implementation of a Peer Mentoring Program for Women in Engineering Students". *Proceedings of the 2006 American Society of Engineering Education Annual Conference & Exposition*.
12. Mitchell, T., and D. Angelitha, 2007. "Start: A formal mentoring Program for Minority Engineering Freshmen". *Proceedings of the 2007 American Society of Engineering Education Annual Conference & Exposition*.
13. Baha, J., T.A. Handy, S.L. Murphy, and E.C. Lemley, 2009. "Mentoring of Freshmen STEM Engineering students by Senior Engineering Students". *Proceedings of the 2009 American Society of Engineering Education Annual Conference & Exposition*.
14. Attarzadeh, F., D. Gurkan, M. Moges, M. Ramos, V. Gallardo, M. Mehrubeoglu, and R. Talusani, 2009. "NSF Grantee presentation: Innovative Approach to Learning via Peer-to-Peer Undergraduate Mentoring in Engineering Technology Laboratories". *Proceedings of the 2009 American Society of Engineering Education Annual Conference & Exposition*.
15. Tsai, J.Y., D.A. Kotys-Schwartz, B. Louie, V.L. Ferguson, and A.N. Berg, 2012. "Graduate students mentoring Undergraduate in research: Attitudes and Reflections About These Experiences". *Proceedings of the 2012 American Society of Engineering Education Annual Conference & Exposition*.
16. Cockrell School of Engineering, University of Texas at Austin. "Graduates Linked with Undergraduates in Engineering (GLUE)" <http://www.engr.utexas.edu/wep/career/glue>
17. American Society of Civil Engineers, 2009. *2009 Report Card for America's Infrastructure*, http://www.infrastructurereportcard.org/sites/default/files/RC2009_full_report.pdf.
18. National Academy of Engineering, 2012. <http://www.engineeringchallenges.org/>
19. Attarzadeh, F., D. Gurkan, M. Moges, M. Ramos, V. Gallardo, M. Mehrubeoglu, 2011. "NSF Grantee presentation: Challenges of Implementing a Peer mentoring Program to Support STEM Learning" *Proceedings of the 2011 American Society of Engineering Education Annual Conference & Exposition*.

Incorporating Field Experiences into Environmental Engineering Lab Courses

Authors: Harmonie A. Hawley, Brian O'Dell

Department of Civil and Environmental Engineering, California State University, Fullerton, Fullerton, CA

Abstract

Laboratories have long been considered a necessary part of engineering education to balance theory with practice. Most introductory, undergraduate Environmental Engineering lab based courses focus on bench-top experiments. These experiments are important and provide the base work for subsequent lab courses. Another important, but often overlooked, lesson is to incorporate field sampling into environmental lab courses. Science majors, such as environmental science and geology, have field experience labs as part of the curriculum throughout the United States. This is a useful skill for Environmental Engineers going into the consulting or research industries.

Two field sampling experiments were incorporated into an environmental engineering class held in the Spring 2012 semester. The lecture material discussed different sampling techniques and the lab portion had the students learn “hands-on” proper sampling methods. The remainder of the lab time was spent learning field equipment for water and air quality analysis. A main learning objective in the class was for the student to be able to determine the most appropriate sampling technique for a specified situation. To assess student learning a practical exam was taken by all of the students, which included scenarios that necessitated the choice of field equipment over bench-top equipment. Overall, the field labs were successful. Based on this outcome, further study is anticipated for the Spring 2013 semester.

Introduction

Engineering labs are an important component of Undergraduate engineering education for all engineering disciplines. Laboratory instruction is used to incorporate practical applications into theoretical classes^{1,2}. Lab courses usually focus on application and critical thinking skills as opposed to knowledge and comprehension (i.e. factual recall)^{3,4}. Flora and Cooper² discuss the importance of labs, including traditional labs and inquiry-based labs, in Environmental Engineering curricula. The authors note that inquiry-based labs are often more time-consuming and costly for the University and faculty and therefore may not be as applicable as traditional laboratory courses. The authors mention a field trip, however do not further discuss if the field trip incorporated sampling and analysis.

Standard Environmental Engineering labs do not incorporate field exercises into the course curriculum. Most introductory, undergraduate Environmental Engineering laboratory based courses focus on bench-top experiments. These experiments are important and provide the base work for subsequent lab courses. Another important, but often overlooked, lesson is to

incorporate field sampling into environmental lab courses. If an objective of the lab course is to include a “real-world” experience, it is important to consider what Environmental Engineers are expected to do in the private, consulting industry. It is common for engineers to conduct field sampling or to oversee field sampling campaigns, thus understanding the proper techniques to collect samples could be deemed an important lesson. Chanson⁵ surveyed 25 senior engineers and managers in Australia and 100% felt that field experience/work was a basic requirement for the Civil Engineering undergraduate curriculum.

Field work in other engineering disciplines was shown to improve student learning. Anderson and Miskimins⁶ evaluated a petroleum-engineering geology field camp as a learning tool for petroleum engineering students and to expose the students to multidisciplinary teams of engineering and geology students (i.e. a shared cognitive interface). The authors found that students who attended the field camp had a better understanding of the geological topics than students who did not attend the camp. The authors concluded that the outdoor field exercises helped students’ understand theoretical knowledge (topics learned in the classroom). Chanson⁵ promoted field work as beneficial for hydraulic engineering students in Australia. Dewoolkar et al.⁷ added a field-based project to a Geotechnical Engineering course and found the project enhanced student learning. In the same study, a student survey was conducted separate of the class and asked students to choose the top five reasons they picked Civil Engineering as a major. One of the most common answers was “to be in the field”⁷.

In addition, science majors, such as environmental sciences, ecology, and geology, include field experiences in undergraduate curriculums throughout the United States^{8,9,10} and Europe¹¹. The importance of field work was recognized in many Environmental science programs from the conception of the program (based on programs started in the 1970s and 1980s)⁸. Field work immerses the students into the complexity of the real world and the complex relationships found in natural environments. Field exercises are shown to enhance the development of practical and observational skills that are not found in typical classroom settings⁹.

Knapp et al.¹⁰ discuss the importance of field work to geology students. The authors also recognize that it is important to include computation, synthesis, and presentation skills as well as field data collection into laboratory curriculum. Scott et al.¹¹ noted the importance of field experience in geography and environmental science curriculums. Scott et al.¹¹ evaluated surveys from students and instructors and found that both groups valued field experiences and felt field work aids in understanding theoretical concepts. In addition, the study found that both groups valued the social benefits of field work, specifically in improving student-student and student-lecturer interactions.

Purpose

The purpose of this study was to evaluate the applicability of field exercises in undergraduate environmental engineering laboratory courses. These lessons are important for engineers who go into research or consulting as field and laboratory work are large components of both positions. A main educational goal of engineering laboratories is to integrate theory and practice. In

addition, engineering laboratories can prepare students for post-graduation work. This lab course was designed to enhance understanding of environmental engineering principles and to support advanced coursework and professional careers.

Implementation

A new Environmental Engineering laboratory course was scheduled into the curriculum for the Spring 2012 semester through the Department of Civil & Environmental Engineering at the California State University, Fullerton. This course was designed to include two field exercises into the semester-long laboratory course; one laboratory was in water sampling and testing and the other laboratory was in air quality sampling.

Assessment

Course objectives and learning outcomes are important components to a course¹ and those written for this laboratory class specifically included field experiences. The course objective was to learn laboratory and field procedures for analyzing water and wastewater and assessing air quality. The student learning goals were to: provide the background for students to know how to operate basic laboratory and field equipment related to environmental engineering, understand lab results, and develop an ability to determine the most appropriate equipment to use for a sampling environment. In addition, as this is an engineering course, the lab objectives were planned to coincide with “real-world” environmental engineering applications.

Assessment strategies were also included in the course. The assessment strategies were chosen before the course began and included both bench-top (laboratory) and field experiments. The main assessment strategy of field experiences was a practical exam. The exam included a station in which a scenario was placed before the student and the student had to choose which piece of equipment was most applicable given the provided scenario. Once the equipment was chosen, the student then had to test a water sample and record the answer. Laboratory reports based on the field laboratories were also required from the students as another learning assessment. The reports showed the students’ ability to collect data and synthesize knowledge from the lecture and laboratory experience. There was also a written final exam based on the entire lab course, which included theoretical principles of proper sampling protocols.

Lecture and Field Exercises

A classroom lecture was necessary to instruct students on: proper theoretical sampling techniques, reasons for choosing certain equipment, and why field samples are important. In addition, a demonstration of proper field sampling procedures was necessary to instruct the students in proper techniques for sample collection. Then, a demonstration was necessary as to the proper use of the field equipment itself. At this point the students collected and analyzed samples. Chanson⁵ found faculty or professional guidance in field labs was essential for students to comprehend the material. Kolari et al.⁴ also used a combination of theoretical lecturing on laboratory procedures followed by the application of the discussed procedures to educate

students.

Incorporating Environmental Issues

These two labs also incorporated environmental health and safety components. Feisel and Rosa¹ cited a 2002 colloquy that listed 13 fundamental objectives for engineering laboratories, of which one was the importance of including environmental issues into laboratories. In addition, the students were exposed to the complex interrelationship between environmental and anthropogenic activities⁹. The students were required to collect any waste (be it hazardous or benign) produced and bring it back to the lab for proper disposal. The theory was anything we brought to the field site was taken back out of the field with the class (bring-in, take-out) to avoid environmental damage. The students' were required to read and understand the hazardous labeling system found on field and laboratory chemicals in order to prevent adverse human impacts or environmental degradation.

Logistics

This lab proved that it is important to know the sampling location prior to choosing the field laboratories (and including them in the syllabus). For this class, travel off of the campus was not necessary. The lack of travel requirement made the lab more practical and increased the amount of time for field sampling exercises without the need to schedule a field trip during non-class time. In addition, the lecture needs to be linked to the field work, thus understanding the field site before the lecture is composed will better synthesize the lecture and laboratory class periods. Lock¹² reported this barrier as a reason for educators to avoid field trips. The logistics of transporting students and equipment can be time consuming for the faculty member. Transportation would also add a cost component to the field work and would need to be evaluated by the faculty member or department⁹. Chanson⁵ noted that field site selection is very important to maximize undergraduate student learning. Dewoolkar et al.⁷ reported that proximity of project sites to the campus was a primary criterion for project site selection.

Field sites for this class were chosen to maximize the experiences for the students. The water quality laboratory had two field sites chosen. The two field sites were located within walking distance of each other and close enough to be completed in one 2 hour and 45 minute class period. The first site was standing water in a pond. The second site was running water. The air quality laboratory involved six to seven sampling locations with each location sampled for ten minutes. The first site was near running water on the grass; the second site was in a desert section of the Fullerton Arboretum to simulate higher dust concentrations; the third site was a quadrangle on campus; the fourth site was near a food truck parked and in operation on campus; the fifth site was a car parking garage to simulate traffic inputs; and the sixth location was inside of a building on campus to evaluate indoor air quality.

If field experiences are not practical, other forms of teaching field exercises could be evaluated for implementation into an existing laboratory or classroom curriculum. Virtual simulations of field labs can be used^{1,3,5,9,13}. Ramasundaram et al.⁹ discuss the benefits and problems in using an environmental virtual field laboratory developed by the authors. Virtual field experiences

Proceedings of the 2013 American Society for Engineering Education Pacific Southwest Conference

Copyright © 2013, American Society for Engineering Education

avoid the problems of accessibility/logistics and the complexity of the natural environment that may overwhelm the student. Limitations include that virtual labs cannot simulate the feel of the natural environments (heat, humidity, etc.) and students with lower computer experience had difficulties understanding the virtual lab compared to those students with higher computer skills. The authors note that virtual labs are good for enhancement of courses, but cannot completely replace field work⁹. Budhu¹³ evaluated a virtual geotechnical engineering laboratory and noted that virtual labs are less expensive, allow easier student access, and have no safety concerns compared to physical labs. The conclusion was the same as Ramasundaram et al.⁹ for environmental field work; the virtual lab could enhance learning, but could not completely replace physical labs¹³.

A faculty member or instructor could demonstrate using field equipment in the classroom or laboratory. This would give the student “hands-on” experience without the need for travel to an outdoor field sampling location. Example outdoor environments could be constructed¹². As an example, small plastic pools can be placed in or near a laboratory and used to demonstrate grab sampling. Proper use of field equipment can be demonstrated in the laboratory (on the bench-top) if needed.

Results and Discussion

The laboratories were successfully implemented in the class. The field exercises were relatively inexpensive compared to traditional bench-top experiments. The initial purchase of field equipment is similar or lower in cost compared to bench-top equipment. A standard grab sampler was used to collect water samples and a Hach® DR890 colorimeter was used for water sampling in the field. Lighthouse® Handheld 3016 Particle Counters were used for the air quality lab.

Student Surveys

Chanson⁵ studied the benefits of field work in undergraduate Hydraulics Engineering courses at the University of Queensland, Australia. Chanson⁵ used student surveys to assess the applicability, from the student perspective, of field work. The results showed students considered field work an essential part of the courses and that the field work helped the students to think critically about the subjects. Glynn and Fergusson¹⁴ implemented a sophomore level Civil Engineering breadth course to increase interest and retention of students in Civil Engineering. The course was a combination of coursework, laboratory work, and field work and covered five disciplines of Civil Engineering (Structural, Transportation, Geotechnical, Hydrology and Hydraulics, and Environmental). The authors found that the course increased retention and interest and that the students showed a better understanding of class concepts in subsequent classes compared to students who did not take the breadth course. Student surveys showed that the students enjoyed the “real” civil engineering projects and experiences.

Dewoolkar et al.⁷ used student surveys to assess Geotechnical engineering courses that were redesigned to include laboratory and field components (technically these were Service Learning

components that involved analyzing a structure, but the projects involved site visitations and in-situ testing, thus the study is included for comparison to this research). The surveys showed that the students perceived that the Service Learning component enhanced their learning experience. In this study, student evaluations from the Spring 2012 semester indicated that students enjoyed the outdoor lab experiences. Further work needs to be completed to assess student evaluations and is planned to continue through the Spring 2013 semester.

Student Evaluations

The laboratory practical administered at the end of the semester was the primary assessment strategy for the student learning objectives. In the Spring 2012 semester the average grade on the laboratory practical was an 84%, or a B-average. This shows that more than half of the class understood the basic operation of field equipment and that the students were able to determine the most appropriate equipment for a field scenario.

Future Work

This laboratory course is currently in session for Spring 2013. Student surveys will be collected at the end of the course semester and can then be evaluated. A comparison between the Spring 2012 and Spring 2013 will be conducted at that time. There is a practical exam scheduled for the end of the semester, which is a main assessment strategy to determine if the student objectives were met. The exam grades will be compared between the two aforementioned semesters to determine if differences were present.

Conclusions

Field experiences can be an important component of undergraduate lab courses. Traditionally, Environmental Engineering lab courses have not used field exercises, but have focused on laboratory exercises. Though these laboratory procedures are important, students can gain valuable knowledge from field exercises. The incorporation of two field exercises into an environmental engineering lab class was evaluated over one semester. The labs were successfully implemented. The next step is to further evaluate the importance of environmental engineering field experience including surveys with professional engineers.

Acknowledgements

This research was in part funded by a 2012-2013 Junior Faculty Grant from the California State University, Fullerton.

References

- ¹Feisel, Lyle D.; Rosa, Albert J. The Role of the Laboratory in Undergraduate Engineering Education. *Journal of Proceedings of the 2013 American Society for Engineering Education Pacific Southwest Conference*
Copyright © 2013, American Society for Engineering Education

Engineering Education. 2005, January, 121-130.

²Flora, Joseph R. V.; Cooper, Adrienne T. 2005. Incorporating Inquiry-Based Laboratory Experiment in Undergraduate Environmental Engineering Laboratory. *Journal Of Professional Issues In Engineering Education And Practice*, 131, 19-25.

³Egemen, E.; Edwards, F.; Nirmalakhandan, N. Computer Simulation Models in Environmental Engineering Education. *Water Science and Technology*. 1998, 38 (11), 295-302.

⁴Kolari, Samuli; Viskari, Eeva-Liisa; Savander-Ranne, Carina. 2005. Improving Student Learning in an Environmental Engineering Program with a Research Study Project. *International Journal of Engineering Education*, 21(4), 702-711.

⁵Chanson, H. 2004. Enhancing Students' Motivation in the Undergraduate Teaching of Hydraulic Engineering: Role of Field Works. *Journal Of Professional Issues In Engineering Education And Practice*, 130, 259-268.

⁶Anderson, Donna S.; Miskimins, Jennifer L. *Journal of Geoscience Education*. 2006, 54 (2), 172-178.

⁷Dewoolkar, Mandar M; George, Lindsay; Hayden, Nancy J.; Neumann, Maureen. 2009. Hands-On Undergraduate Geotechnical Engineering Modules in the Context of Effective Learning Pedagogies, ABET Outcomes, and Out Curricular Reform. *Journal Of Professional Issues In Engineering Education And Practice*, 135, 161-175.

⁸Weis, Judith S. 1990. The status of undergraduate programs in environmental science. *Environmental Science & Technology*, 24(8), 1116-1121.

⁹Ramasundaram, V.; Grunwald, S.; Mangeot, A.; N.B. Comerford, N.B.; Bliss, C.M. 2005. Development of an environmental virtual field laboratory. *Computers & Education*, 45, 21-34.

¹⁰Knapp, Elizabeth P.; Greer, Lisa; Connors, Christopher D.; Harbor, David J. Field-Based Instruction as Part of a Balanced Geoscience Curriculum at Washington and Lee University. *Journal of Geoscience Education*. 2006, 54 (2), 103-108.

¹¹Scott, Ian; Fuller, Ian; Gaskin, Steve. 2006. Life without fieldwork: Some Lecturers' Perceptions of Geography and Environmental Science Fieldwork. *Journal of Geography in Higher Education*, 30(1), 161-171.

¹²Lock, Roger. 1998. Fieldwork in the life sciences. *International Journal of Science Education*, 20(6), 633-642.

¹³Budhu, Muniram. 2002. Virtual Laboratories For Engineering Education. *Proceedings of the International Conference on Engineering Education*, August 18-21, 2002, Manchester, U.K.

¹⁴Glynn, E. F.; Fergusson, W. B. 1994. Innovative Introduction to Civil Engineering Curriculum. *Journal Of Professional Issues In Engineering Education And Practice*, 120, 149-157.

Encouraging Women to Transfer into Engineering Programs from 2-Year to 4-Year Colleges

Authors: Lucia Riderer, Harmonie A. Hawley

**Physics Department, Citrus College, Glendora, CA /Department of Civil and
Environmental Engineering, California State University, Fullerton, Fullerton, CA**

Abstract

Women have long been an underrepresented group in the engineering community. Currently, research is being conducted throughout the United States on methods to retain women in engineering programs. Women in junior, or 2-year colleges, are often overlooked as potential members of the engineering community; however there are many women interested in engineering at junior colleges. Encourage and Engage Women In Engineering (EEWIE) at Citrus College is a program intended to guide and keep women on track to transfer from a 2-year college to a 4-year college with a major in an engineering discipline. The program has successfully operated for one complete year (2012). Over the past year the women who joined EEWIE have worked with peers at 2-year and 4-year colleges, women faculty from 4-year colleges, and women engineers in the industry who provided honest opinions to the group about the fields of engineering.

Vital to the success of this program was linking the group with students and faculty at 4-year colleges. This collaboration allowed EEWIE members to interact with women engineers who were in college or graduated and were able to help them with the transition from general education courses to engineering courses. Meeting women who succeeded in the engineering curriculum gave the students confidence that they could be engineers. Connecting the EEWIE women with female peers in engineering programs offered credible insights and encouragement for the women as they could relate to peers with similar problems. This is a model program from which many other colleges, universities, and students could benefit.

Introduction

Women have long been an underrepresented group in the engineering community. It is estimated that in the United States only 17.8 % of bachelor degrees were obtained by women in 2009¹. Currently, research is being conducted throughout the United States on methods to retain women in engineering programs². Another area of research is how to get more women interested in Engineering majors. Women in junior, or 2-year colleges, are often overlooked as potential members of the engineering community; however there are many women interested in engineering at junior colleges.

Community colleges can be institutions of high significance in bridging students to baccalaureate institutions to pursue a degree in Science, Technology, Engineering, and Mathematics (STEM) disciplines. The results of a study conducted by Tsapogas³ showed that about 44 percent of

students who earned a bachelors or masters degree in a STEM-related field have been enrolled in classes at one or more community colleges during their academic career at a four-year university. In addition, more women attend community colleges than four-year institutions, as indicated by the U.S. Department of Education⁴. It has been shown that community colleges play an important role in increasing the number of women in STEM disciplines and careers⁵.

Citrus College is a 2-year college located in Glendora, CA, in Los Angeles County. The Fall 2010 enrollment was 14,386 students. According to the Citrus College Fact Book⁶ about 54% of the students enrolled in classes at Citrus College are female. The percent enrollment of female students in higher level mathematics and physics courses (i.e. courses needed to transfer to a 4-year Engineering program) is much lower. In Spring 2011, 79 students were enrolled in Multivariable Calculus and Differential Equations of which approximately 19% were women. In the same semester, the student enrollment in Trigonometry and Introduction to Physics courses were about 50% women (250 total students). A survey conducted by the faculty member of the lower level courses found that only one female out of the 32 female students who participated in the survey was interested in Engineering and 12 were undecided. The undecided students were further asked if they would consider a major in Engineering; the most common responses from the students were “I am scared that I am not going to be successful in higher level math and physics”, “I don’t know anyone who is an engineer,” and “I am not a hands-on person.”

Earlier studies have noted that many women do not finish engineering programs because of a lack of self-confidence as opposed to poor performance in course work⁷. Brainard and Carlin⁷ found that female science and engineering students ranked the Women In Engineering Initiative and the student group Society of Women Engineers as factors influencing their decision to stay in engineering and science disciplines. It can be deduced from the Brainard and Carlin⁷ study that a support network was important to female students. Marra et al.² also found that women in engineering did not have a sense of inclusion or sense of community in the engineering field.

The primary mission of EEWIE was to foster interest in Citrus College female students in engineering through interaction with undergraduate female students majoring in engineering at baccalaureate institutions and faculty mentors who possess a deeper understanding of engineering in a welcoming environment conducive to discovering engineering disciplines⁸.

Methodology

The EEWIE program operated for the entire calendar year of 2012. EEWIE was a multi-component program designed to create a support network and community for women enrolled in mathematics and science courses at the Junior College. Mathematics and physics courses were chosen as the most conducive courses to transfer to a 4-year, baccalaureate degree, Engineering program.

There were three main components of the program. The first component was “Tools For Engineering”; peer led workshops associated with mathematics and physics courses. The second component was “Focus on Engineering:”; a multi-level peer mentoring program that involved

students at 4-year colleges, Citrus College students, and elementary and middle school students (grades 3 to 8). The third component was “Links to Engineering”. The third component is the focus of this paper and is described in detail.

Links to Engineering was designed to link Citrus College female students in EEWIE to female engineers at 4-year colleges and in the industry. There were three main components of Links to Engineering. The first part was presentations and discussions by faculty and students at 4-year universities. The second portion was field trips. The third portion was participation in research projects related to an engineering discipline.

Results

Seventeen (17) women students from Citrus College participated in the EEWIE program. Ten (10) of those students are still at Citrus College with plans to graduate from Citrus College and transfer to a 4-year institution. Six (6) of the students transferred to 4-year universities; the universities were University of California Los Angeles, University of California San Diego, Columbia University, California State University, Los Angeles, and California Polytechnic University, Pomona. The students are currently majoring in Mechanical Engineering, Chemical Engineering, Computer Science, Biochemistry, Biology, and Accounting.

The first component of Links to Engineering was accomplished through two presentations and peer mentoring (which falls under the Focus on Engineering task and is therefore not further discussed here). Faculty member Dr. Harmonie Hawley, accompanied by a graduate student and an undergraduate student who was the President of the Society of Women Engineers at the time, conducted an open forum style discussion on April 13, 2012. The three presenters were all affiliated with the California State University, Fullerton. The Engineering disciplines represented were Civil & Environmental, Mechanical, and Chemical Engineering. The open forum style allowed the Citrus College students to ask questions and promote discussions amongst the faculty and students. Some of the main topics discussed were the different engineering majors, what can be done with an engineering degree, how to obtain funding for graduate school and the benefits of graduate school, and what standardized exams exist for engineers. A second presentation was held on June 1, 2012 by Dr. Joann Eisberg from Chaffey College. Dr. Eisberg discussed the role of women in science and society; she encouraged the EEWIE members to study at the graduate level and to pursue their career dreams.

Three field trips were held throughout 2012 as part of the second component of Links to Engineering. Several EEWIE members visited the Jet Propulsion Laboratory in Pasadena, CA and the Uninhabited Aerial Vehicle Laboratory at California State Polytechnic University, Pomona during the summer, 2012. Two of the EEWIE participants attended a three-day NASA Advanced Rocketry Workshop in Huntsville, Alabama from July 18 to 21, 2012.

The final component of Links to Engineering was to have students work on Engineering-related research projects. Members were not required to conduct research, but several students opted to do so. Three EEWIE members joined the Citrus College Rocket Owls (total team size was six

students); the Rocket Owls are participating in the 2012-2013 NASA University Student Launch Initiative competition (USLI). USLI required students to design, build, and launch a reusable rocket one mile above ground level. Two EEWIE members linked with students at the California State Polytechnic University, Pomona to create a High Altitude Balloon (HAB) team. The students are working to design, build, and fly a device to take dosimetric measurements of ionizing radiation at different altitudes. The students plan to launch their device in Spring 2013. One member of EEWIE performed a research experiment during Summer 2012 entitled “Efficiency of Compressed Air Energy Storage”.

Discussion

Surveys were given out to members of EEWIE to assess student engagement and the applicability of the program. Nine responses were collected from the program. The results showed that the participating women found the Links to Engineering program to be useful and encouraged them to evaluate engineering as a major. There were five potential answers to each of the 35 questions: strongly agree, agree, neutral, disagree, and strongly disagree. Only questions related to the Links to Engineering component are discussed in this paper.

Component One: Presentations and Discussions

When asked to respond to “Inauguration and Meeting Mentors (1/5/2012) contributed to my sense of community, engagement and encouragement (Or check if you did not attend____)”, seven students responded Strongly Agree and two students did not attend the event. This question was not explicitly related to Links to Engineering events, but both authors attended the event and met with the students. The inauguration was attended by Deans and Faculty of Citrus College as well as outside mentors from California State Polytechnic University, Pomona (peer mentors) and the California State University, Fullerton (faculty).

When asked to respond to “Open Forum with Dr. Harmonie Hawley (4/13/2012) contributed to my sense of community, engagement and encouragement. (Or check if you did not attend____)”, five students responded Strongly Agree, one student was neutral, and three did not attend.

When asked to respond to “Lunch conversation with Dr. Eisberg (6/1/2012) contributed to my sense of community, engagement and encouragement. (Or check did you did not attend____)”, four students responded Strongly Agree and five students did not attend.

When asked the open ended question “In what ways could the Encourage and Engage program change/improve?”, there were five typed in responses. Three of the five responses were related to “Links to Engineering” in that outreach and understanding the different engineering disciplines were important. The first comment was “Invite more people to talk about the career field after graduating”. The second related response was “Have speakers come and tell us about different fields, students and teachers could tell us how to best prepare for school or the work life. A day in a life as an engineer would be interesting to know”. The final related comment was “I suggest have more outreach experiences so that we can have more hands on experience

and feel interested in engineering”. Lent et al.⁹ concluded that understanding the outcome expectations of a career was shown to be a factor in retaining students in engineering disciplines. This study also found that understanding the career outcome was important to the women students.

Similar results were found in other programs. Citrus College has a program entitled “Support and Inspire” Program for Women in Mathematics. The main goal of this program is to increase interest in mathematics by acting as peer mentors and interacting with professional women mathematicians. In 2010, surveys were conducted with members of the program and data analysis showed that Citrus College female students were inspired by female role models¹⁰. Muller¹¹ reported that mentors from the engineering industry are important role models for women engineering students and is a method shown to improve retention of female students. Mentors who are more experienced than the students can enlighten the students about career opportunities and provide support, advice, and encouragement. Marra et al.² concluded that there is a need for extracurricular activities, such as academic success seminars, to retain women in engineering.

Hartman and Hartman¹² conducted a study on engineering students who stayed in Engineering and students who left engineering at Rowan University. Their findings were that women had the same or higher retention rates than their male counterparts during the study. The authors concluded that the program was “female-friendly”. Further analysis was conducted on the women who stayed in engineering versus women who left engineering. Hartman and Hartman¹² found that the women who left engineering were worried about the freedom of a job in engineering and, relatedly, problems with conflicts over career and family. Engineering women who participated in the Society of Women Engineers and women who had internships/employment in engineering were less likely to perceive career-family problems. This suggests a reason for female attrition in engineering; however it appears to be alleviated by professional experiences in the Industry or by a support network. Hartman and Hartman¹³ conducted another study from 2002 to 2006. This study again found that perception of career-family conflicts was a problem for women, as was a lack of female role models. These issues can be alleviated by joining student groups, such as Society of Women Engineers or EEWIE, and speaking with professional women engineers.

The previous studies focused on retaining female students at 4-year institutions and found that support networks and mentoring were important for the students. This study focused on engaging 2-year college students in activities to increase their interest in transferring to engineering programs. The authors were unable to find research directly related to the transfer of females to engineering from 2-year colleges. This shows that more work in this area is needed to assess recruiting and retaining engineering students. There are potential female, and male, engineers that may be overlooked.

Component Two: Field Trips

There were no specific survey questions related to the field trips. It is the authors' advice to specifically ask questions regarding the field trips in future work. Support and Inspire¹⁰ evaluations showed that field trips were ranked highly as an important feature of the program.

Component Three: Engineering-Related Research Projects

The students who participated in research projects were asked to evaluate the usefulness of the research using the aforementioned scale. Of the three EEWIE women who joined the Rocket Owls, two students responded Strongly Agree and one student responded Not Applicable. When asked to analyze the High Altitude Balloon (HAB) project, two students responded Strongly Agree and one student responded Not Applicable. It can be assumed the student/s that responded "Not Applicable" were not members of the project, but responded to the question. The results from the survey indicate that projects had a positive influence on the students' success.

In general, undergraduate research has been shown to positively impact engineering and science education¹⁴. Though not specific to retention of students, the study shows that students gain beneficial experience by conducting research. There are Universities throughout the United States that require engineering students to conduct research or clinics to graduate with a Bachelors degree, including Worcester Polytechnic Institute and Rowan University.

Conclusions

The EEWIE successfully operated for the year of 2012. The women participants were encouraged to evaluate STEM fields for a Baccalaureate degree, with six graduating females attending four year universities. Vital to the success of this program was linking the group with students and faculty at 4-year colleges and Engineering professionals. Research projects were shown to have a positive influence on the women students.

Acknowledgements

This project was funded by the Engineering Information Foundation, Grant Contract Number EiF11.10.

References

- ¹Backer, Patricia R.; Halualani, Rona Tamiko. 2012. Impact of Self-Efficacy on Interest and Choice in Engineering Study and Careers for Undergraduate Women Engineering Students. Proceedings of the American Society of Engineering Education Annual Conference 2012.
- ²Marra, Rose M.; Rodgers, Kelly A.; Shen, Demei; Bogue, Barbara. 2009. Women Engineering Students and Self-Efficacy: A Multi-Year, Multi-Institution Study of Women Engineering Student Self-Efficacy. Journal of Engineering Education, January 2009, 27-38.

- ³Tsapogas, J. 2004. The role of community colleges in the education of recent science and engineering graduates. Info Brief, 4-315. Arlington, VA: Division of Science Resources Statistics, National Science Foundation.
- ⁴U.S. Department of Education. 2008. The condition of education. (NCES document 2008-031). Retrieved from <http://nces.ed.gov/fastfacts/display.asp?id=77>.
- ⁵Starobin, S. S., & Laanan, F. S. 2005. Influence of Pre-college experience on self-concept among community college students in science and engineering. *Journal of Women and Minorities in Science and Engineering*, 11(3), 209-230.
- ⁶Citrus College Fact Book. 2009. Citrus College Office of Institutional Research. Available for download at <http://www.citruscollege.edu/admin/research/Pages/FactBook.aspx>.
- ⁷Brainard, Suzanne G.; Carlin, Linda. 1998. A Six-Year Longitudinal Study of Undergraduate Women in Engineering and Science. *Journal of Engineering Education*, October 1998, 369-375.
- ⁸Riderer, Lucia. Final Report: Citrus College EiF11.10 Grant. Submitted to: Engineering Information Foundation, January, 2013.
- ⁹Lent, R. W.; Brown, S. D.; Hackett, G. 2000. Contextual supports and barriers to career choice: A social cognitive analysis. *Journal of Counseling Psychology*, (47): 36-49.
- ¹⁰Support and Inspire. 2010. Women in Mathematics Evaluation by Participants. Available for download at <http://www.citruscollege.edu/academics/wim>.
- ¹¹Muller, Carol B. 1997. The Potential of Industrial “E-Mentoring” as a Retention Strategy for Women in Science and Engineering. Proceedings of the Frontiers in Education Conference, 1997, 27th Annual Conference. ASEE, November 5-8, 1997, Pittsburgh, PA, 622-626.
- ¹²Hartman, Harriet; Hartman, Moshe. 2006. Leaving Engineering: Lessons from Rowan University’s College of Engineering. *Journal of Engineering Education*, January 2006, 49-61.
- ¹³Hartman, Harriet; Hartman, Moshe. 2008. How Undergraduate Engineering Students Perceive Women’s (and Men’s) Problems in Science, Math and Engineering. *Sex Roles*, 58, 251-265.
- ¹⁴Zydney, Andrew L.; Bennett, Joan S.; Shahid, Abdus; Bauer, Karen W. 2002. Impact of Undergraduate Research Experience in Engineering. *Journal of Engineering Education*, April 2002, 151-157.

Teaching Bioinformatics in Concert: an Interdisciplinary Collaborative Project-based Experience

Alex Dekhtyar, Anya L. Goodman, Aldrin Montana
Department of Computer Science, Cal Poly San Luis Obispo,
dekhtyar@calpoly.edu/ Department of Chemistry and Biochemistry. Cal
Poly San Luis Obispo, agoodman@calpoly.edu/ Department of Computer
Science, Cal Poly San Luis Obispo, amontana@calpoly.edu

Abstract

In the Spring of 2012 we piloted a novel approach to interdisciplinary instruction in the area of bioinformatics that enables undergraduate students in life sciences to work “*in concert*” with computer science students to solve biological problems. Our approach relies on well-defined **interdependent** roles for biology (BIO) and computer science (CS) students in a project-based laboratory.

We recognize distinct learning objectives for each major and implement them in two separate courses taught side-by-side: Bioinformatics Applications for BIO majors and Bioinformatics Algorithms for CS majors. We rely on separate lectures for each group of students, but in laboratory we form joint interdisciplinary teams to work on building software for solving specific biological problems. The teams rely on the biological expertise of BIO students and the software development skills of CS students to produce the software and to use it to obtain requested results. For each assignment, BIO students developed a set of software requirements for a computational biology question, provided it to the CS students on their team, and participated in design and testing of the software as it was being built.

In this paper we present the results of our pilot offering of the two courses to 24 BIO and 35 CS students. We collected and evaluated a variety of student artifacts and conducted extensive surveys in both courses. We discovered that both BIO and CS students indicate improvement in the quality of work of their partners over the course of the quarter. The majority of students reported increased confidence in their ability to collaborate with colleagues outside of their discipline. We discuss these and other findings and present our plans for improvement of our approach for the Spring 2013 offering.

1. Introduction

Beyond higher education, computer science has always been an interdisciplinary field. The vast majority of software serves purposes outside of the pure field of computing, and thus, building software has always involved software developers collaborating with customers who came from a wide range of fields.

At the same time, this interdisciplinary nature of the field, best expressed as “we build software for everyone’s needs”, finds scant reflection in computer science education. Traditional undergraduate computer science (CS) curriculum emphasizes technical proficiency, problem-solving skills, and breadth within the field of computer science, leaving learning about the

interdisciplinary nature of the field mostly off the required experience. Senior projects, capstone experiences and occasional project-driven software engineering courses provide the only opportunities to experience cross-disciplinary collaboration within CS curricula.

Among the variety of possible reasons why systematic treatment of the interdisciplinary nature of computer science is hard to find in college, *while its very importance is well-recognized by the academic community* [3], one stands very clear. Courses that provide meaningful interdisciplinary experiences for students are *hard to develop* and are *hard to teach*. While specific perception of what constitutes a “meaningful interdisciplinary experience” may vary from person to person and from department to department, in this paper, we view as “meaningful” experience, an experience students get in a regularly taught course that

1. features exposure to computational (and/or software engineering) problems in a field of study outside of computer science/software engineering/computer engineering;
2. involves students and experts (faculty, professionals from outside) from both computer science and the other discipline;
3. provides some form of a hands-on software development experience that includes participants from more than one field.

The two key challenges with developing and teaching courses that satisfy these conditions are (i) the need to attract course participants from outside of computer science and (ii) the need for the course instructor to possess some level of expertise in the second field.

These challenges can be specifically observed when bioinformatics, one of the most popular emerging cross-disciplinary fields involving computer science, is considered. As a field of professional activity, bioinformatics requires in-depth knowledge of both computer science and biology – something that is impossible to achieve in the confines of a single course. Yet, many computer science programs simply do not possess the requisite personnel (i.e., enough computer science faculty with expertise in life sciences in general and/or bioinformatics specifically) to develop and offer a full-scale study in bioinformatics, limiting the possible curricular options to a single bioinformatics course offered as a technical elective for interested students. Similar situation is observed in the Biology/Biochemistry programs.

The key difficulty in offering bioinformatics courses as technical electives in the computer science program lies in the choice the instructor has to make. An in-depth course on bioinformatics algorithms requires significant computational background, and is inappropriate for students outside of computing majors (and *very occasional* biology majors with a CS minor). An attempt to develop a computer science bioinformatics course that would bring biology students alongside computer science students to the same room, therefore, has, by necessity, to forego any topics that require prior computational experience. But what if *both* technical depth and *bona fide* interdisciplinary experiences are desired?

In 2009, Pevzner and Shamir recognized the difficulty of offering truly cross-disciplinary bioinformatics courses, and posed an educational challenge asking for the means of developing a bioinformatics course that

1. assumes few computational prerequisites;
2. assumes no knowledge of programming;

3. instills in students a meaningful understanding of computational ideas and ensures that they are able to apply them [7].

In response to this challenge, and to the additional challenge of giving students a “meaningful interdisciplinary experience” (as defined above), in Spring 2012 we successfully piloted an approach that relies on *two instructors*, one from each discipline, teaching *two different but tightly interconnected bioinformatics courses*, one for each major, collaborating on preparing and teaching the courses. We termed this approach *in-concert teaching*. This approach allows students of both majors to take a technical elective course in their discipline, while at the same time actively participating in a full-quarter interdisciplinary experience involving their peers from the other course.

The rest of this paper is organized as follows. In Section 2 we discuss in detail the concept of *in-concert teaching*. In Section 3 we show how this concept was applied to our teaching of two bioinformatics courses. In Section 4 we discuss our pilot evaluation and its results. Finally, Section 5 outlines the improvements we are planning to implement in the two courses in their Spring 2013 offering.

In this paper, our main goal is two-fold: (a) we discuss the impact of *in-concert* teaching on the experience of computer science students and (b) we discuss the specific way in which we approached the “instilling meaningful understanding of computational ideas” challenge of Pevzner and Shamir [7] for BIO majors.

2. Teaching *In-Concert*

In-concert teaching (or teaching *in concert*) is the name we gave to an approach we developed for teaching two concurrent courses presenting two different *discipline-specific* perspectives (from two different disciplines) on a specific topic. The key characteristics of teaching *in-concert* are:

- **Two discipline-specific courses** stressing technical proficiency within the chosen field of study.
- **Instructors from respective fields:** each course is taught by the instructor from the respective program/department.
- **Joint preparation.** The content of both courses is prepared in collaboration between both instructors.
- **Physical and temporal co-location:** the courses are taught on the same schedule, and, at least for a portion of each course, *occur in physically collocated spaces* (e.g., two neighboring classrooms, or two neighboring labs, or, possibly, a single lab), so that students from both classes could pursue...
- **...shared hands-on projects involving teams of students from both classes.** Interdisciplinary student teams are formed from students of both classes. A non-trivial portion of class time is devoted to interdisciplinary team activities.
- **Students as experts in their field.** While working on joint interdisciplinary assignments students from each course assume roles of experts in their field of study.

- **Exposure of students to knowledge from the other discipline** via interdisciplinary team assignments and via occasional *cross-teaching*.

Informally, the idea of *in-concert* teaching is for two instructors from two different programs to jointly prepare the content of two courses, connected at the level of *shared major coursework* that is performed by teams formed of students from both courses using shared time, space and resources. While not a direct requirement for *in-concert* teaching, the concept can be aided nicely by a number of complementary educational techniques, such as

- **Reverse course design:** course development starts with basic concepts instructors are interested in, proceeds with determination of the joint assignments, from which, in turn, the specific theoretical course material and teaching schedules are derived [8,9,10]¹.
- **Inverted classrooms:** can be used in either or both courses to drive both discipline-specific and cross-disciplinary learning [11,12]².
- **Undergraduate research:** joint assignments can be part of an undergraduate research experience, and can directly contribute to generation of new knowledge in classroom.

Structurally, we can identify three different modes of instruction within the *in-concert* teaching environment:

1. **Discipline-specific instruction:** instruction within each course on the discipline-specific concepts related to the overall subject of the study.
2. **Joint labs:** joint hands-on work on cross-disciplinary assignments.
3. **Cross-teaching:** introduction to the necessary aspects of the other discipline presented to each class by the instructor of the *other* course.

The first teaching mode is the “traditional” course instruction that concentrates on studying parts of the subject that are directly related to the specific discipline of the course. It can be done either as a lecture or as an inverted classroom exercise, but it involves the course instructor interacting only with students from *their* course. The hands-on part of the course brings students from both courses together to work on the joint assignments. Instructors of both courses share the responsibility for working with these teams. Finally, on some occasions, students in each course may need to receive some training/information pertaining to the other discipline. This is done via cross-teaching: instructor of one course coming to present a lecture or conduct an activity in the other course. The presented material is targeted *specifically* at the students from the other discipline and is, as a rule, separate from the discipline-specific lectures/activities/training.

One of the key aspects of *in-concert* teaching is that by splitting an interdisciplinary course into two discipline-specific courses, it allows for course instructors to have minimal expertise in the other discipline. In essence, in preparing and delivering *in-concert* coursework to students, course instructors go through a similar experience of joint collaborative cross-disciplinary work, in which they contribute the knowledge from their field.

¹ The earliest ideas (studying the needs/objectives, followed by selecting activities, organizing these activities, and choosing evaluation methods) were proposed by Tyler in 1949 [8]. More recently, these were organized and popularized by Wiggins and McTighe [9,10].

² Here “inverted classroom” (a.k.a. “flipped classroom”) is used to refer to a set of course instructional techniques, where students learn theoretical/lecture material on their own outside of the classroom, and spend classroom time in active learning activities.

3. Teaching Bioinformatics *In Concert*

We piloted our *in-concert* teaching on the base of two courses: CSC 448: Bioinformatics Algorithms taught by the first author, and BIO 441: Bioinformatics Applications taught by the second author. Both courses were already on the books of respective programs, which allowed us to forego new course proposals. The two courses, however, have different back stories. The Bioinformatics Algorithms course was proposed as a computer science technical elective at the turn of the century and has been taught once or twice by a different faculty member, after which due to personnel changes it has essentially become a dormant course. The Bioinformatics Applications course is a technical elective in Biology and Biochemistry programs and prior to Spring 2012 it has been taught on an annual basis.

Both classes come with six contact hours per week: three hours for lecture and three hours for lab, which made physical coordination of the courses straightforward. In what follows, we provide a brief description of the organization of the two courses, course content, joint assignments and the overall course flow.

Logistics. Both courses were offered during the same time periods on a Tuesday-Thursday schedule. Both courses used computer labs run by the department of Computer Science. BIO 441 took place in its entirety in one computer lab. CSC 448 had a lecture set in a classroom elsewhere on campus, with a lab period taking place in a computer lab next door to the one in which BIO 441 took place. The lab for the CS course was unoccupied during the lecture timeslot, so, on occasion, the entirety of CSC 448 happened in the lab, or the class was brought to the lab early.

24 students took the Bioinformatics Applications course, with the majority coming from Biology, Biochemistry and Animal Science majors, although the course was also taken by one Political Science and one Math major. 35 students took Bioinformatics Algorithms course. Most students were Computer Science or Software Engineering majors, with a few Computer Engineering majors and one Physics major.

For the hands-on part of the course we formed 12 teams consisting of two BIO 441 students and three CSC 448 students (except for one team, which only contained two CS students). The BIO pairs and the CS triples were formed by the two instructors independently based on first-day surveys. BIO students were primarily matched by attitude (how hard they expected to work in class). CS students were organized to provide balance, with each team having at least two students who completed the Intro to BIO or Intro to Chemistry sequence, some software engineering experience (having taken a software engineering course required for CS and SE majors) and with at least one student per team having taken the Algorithms course.

Throughout the course, teams wound up having 2-3 hours of face time per week. During most lab periods, each team worked together, with odd-numbered teams occupying one of the two labs and the even-numbered teams residing in the neighboring lab. Each team received its own work space (two sides of a computer lab isle) that allowed the team members to both work

independently on their own tasks, as well as join together for a team meeting by simply turning the chairs around, as shown in Figure 1.

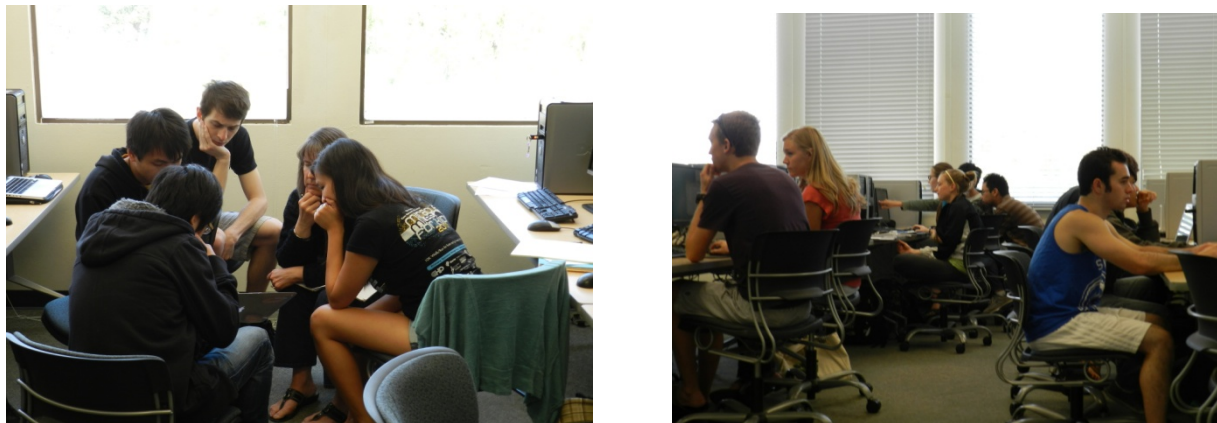

Figure 1. Students work together (left) and separately (right) on their assignments during joint lab periods.

Curricula. The curricula for the two courses have been co-designed by the course instructors in the *reverse course design* fashion. As a starting point, the instructors agreed on the set of learning objectives for each course. The learning objectives are presented in Table 1.

Table 1. Learning objectives for the two Bioinformatics courses.

CSC 448: Bioinformatics Algorithms	BIO 441: Bioinformatics Applications
1. Know main problems in bioinformatics	1. Use and explain bioinformatics concepts/terminology
2. Understand key bioinformatics algorithms	2. Use web-based tools to access gene/genome information
3. Model bioinformatics problems	3. Use scientific method to investigate questions related to gene structure and function
4. Apply algorithmic techniques to solve bioinformatics problems	4. Convert a biological question into a computational problem
5. Effectively communicate and cooperate with colleagues in biology and computer science	

To support the learning objectives of the BIO 441, we used two intertwined course-long assignments based on the work of the Genomics Education Partnership (GEP) [1,6]. GEP is a community of biology faculty who develop and incorporate in undergraduate curriculum research projects related to fruit fly genomes. One of the two course-long assignments in BIO 441 was annotation of genes in the *Drosophila mojavensis* genome, a project that BIO 441

students completed independently of CSC 448 students. The second assignment used two regions of *Drosophila erecta* genome, Chromosome 3 and Chromosome 4. It asked students to conduct a comparative study of the two chromosomes and look for differences in organization of genetic information. The instructors broke the overall assignment into a sequence of individual tasks that had to be completed by the joint teams of BIO 441 and CSC 448 students. Each task asked BIO students a specific research question, or asked them to prepare the genome data provided to them in a specific way. Either way, the BIO students had to turn their assignment into a formal software requirements specification provided to the CS students. The CS students developed software solving the given problem, deployed it for the use of the BIO students, who then ran it on their data and reported the results.

BIO 441 lectures covered the specifics of genome analysis, required for the students to be able to successfully complete the gene annotation project, and to be able to successfully explain through documentation and conversation the requirements for the software that the CSC 448 had to build.

The content of the Bioinformatics Algorithms course was built to match the specific programming assignments. The topics covered in both courses are listed in Table 2.

Table 2. Topics covered in the two courses.

week	CSC 448 topic	BIO 441 topic
1	Biology background	Bio and software engineering background
2	DNA analysis (codon bias, %GC, entropy)	DNA sequencing technologies genome sequencing (HGP)
3	String matching	Genome annotation, UCSC genome browser, custom tools
4	Suffix Trees	Sequence comparison: dot plot, local and global alignments
5	Suffix Trees	Genome annotation (practice contig)
6	Repeats and palindromes	Chromatin and gene expression
7	Alignment (Dynamic Programming)	Comparative genomics
8	Alignment (FASTA, BLAST)	Research paper: 12 fly genomes
9	Alignment (FASTA, BLAST)	Research
10	Clustering	Research

The key topics covered in the Bioinformatics Algorithms course were DNA measures (codon bias, GC percent, DNA entropy), exact string matching algorithms (Knuth-Morris-Pratt, Boyer-Moore) and suffix trees and their uses for string analysis, string alignment using dynamic programming techniques and using approximation techniques (FASTA, BLAST) and clustering.

Each topic, with the exception of clustering was tied to a lab assignment, requiring the students to adopt, adapt and implement the algorithms covered in lecture to address a specific problem supplied to them by their team partners from BIO 441.

Labs. Both classes came together for 2-3 hours a week to work joint lab assignments. Starting the first week of classes, where students from both classes participated in ice-breaking activities involving Computer Science Unplugged games [2,4] and joint work on a task of finding and retrieving genome data from on-line databases, and going through the last week of classes, when the teams worked jointly on the oral presentation for BIO students and poster for CS students, all labs targeted *joint work* of students in cross-disciplinary teams (the stable teams were formed on the second week of the classes; the ice-breaking activities of week one were performed by constructing *ad hoc* teams for each lab). Table 3 shows the list of laboratory assignments in the two courses.

Table 3. List of joint lab assignments in CSC 448/BIO 441

Lab	Name
0	CS unplugged: Marching Orders
1	Applications: Genes and Traits
2-1	DNA sequence analysis: GC content
2-2	DNA sequence analysis: Codon Usage Bias
3-1	Contig assembly (Overlap, Boyer-Moore)
3-2	Repeat Search, Palindromes (Suffix Trees)
4	Alignment (conflict resolution)
5	Poster (CS)/Presentation (BIO)

The core programming assignments in the course consisted of Labs 2-1, 2-2, 3-1, 3-2 and 4. In terms of technical assignments for CS students, both parts of Lab 2 dealt with building software for measuring different properties of DNA sequences. Lab 3 assignments were reduced to different approaches to exact string matching problems and their extensions, such as palindrome detection. Lab 4 involved implementation of a dynamic programming algorithm for global alignment. Each assignment was structured in a similar way:

1. **Origination:** the BIO 441 instructor explained to BIO 441 students the specific question to be addressed.
2. **Requirements:** BIO 441 students prepared a requirements specification for CS students.
3. **Design:** CSC 448 students obtained the requirements specification from their BIO 441 teammates. The teams worked together on ensuring that CS students understood what software needed to be built. CS students worked (informally, no formal specifications were required) on the design of the solution.

4. **Implementation:** CSC 448 students worked on implementing the software.
5. **Testing:** both CS and BIO students participated in testing of the software. CS students used feedback from BIO students to both fix bugs in the code and to improve the usability of the software, ensuring the BIO students would be able to run the software by themselves.
6. **Deployment and use.** CS students delivered the final version of the software to the BIO students, who used it on their data to either answer the research questions posed in the lab assignment, or to prepare the data for the next assignment.

Steps 2-6 of this process happened during the joint lab periods. The time frames for different labs varied. Lab 2-1 was designed to be completed in a single lab period -- by the end of the lab period, teams were expected to produce a simple but usable program computing GC percent in an input DNA fragment. Other labs usually had a two-week window, although some deadline slippage occurred: in the second half of the course teams often worked on multiple lab assignments in parallel – testing and maintaining/debugging code from an older assignment, while building requirements and design for a newer one.

For Step 4, when CS students were fully engaged in activities (coding) where their BIO partners were largely not needed, BIO students worked on their genome annotation assignments, while staying in close proximity of their CS partners, in case consultations were required (see Figure 1, right).

While CS students got detailed instructions from the course instructor concerning the specifics of work organization and deliverables for each assignment, as well as hints as to what algorithms needed to be implemented, the actual nature of assignment was conveyed to the CS students by their BIO partners. We felt that it was important to engage students from both courses in direct communication as soon as the assignments came out, and we felt that BIO students explaining the nature of the assignment, and why they needed the software to complete their tasks added an important wrinkle to the overall experience of both BIO and CS students. The former got to experience the role of experts in their field. The latter obtained an important experience of knowledge engineering from non-technical customers.

Cross-teaching. At the beginning of the quarter the CSC 448 instructor gave a guest lecture to the BIO 441 students describing the software development process, and outlining the importance of each of the steps in the process. To illustrate the process, the V model of software development [5] was used, in which the steps of the software development process are plotted in the form of the letter “V”. Five stages were discussed: *Requirements*, *Design* (the left “arm” of the “V”), *Implementation* (the “point” of the “V”), *Testing* and *Deployment/Maintenance* (the right “arm” of the “V”). A special emphasis was given to the *Requirements* stage.

To help BIO 441 students prepare requirements for the lab assignments, the course instructors developed a simple requirements template. The template listed different types of requirements (functional requirements, non-functional requirements, design constraints, process constraints). Functional requirements were broken into three categories: input specification, output specification and processing instructions. BIO 441 were asked to fill the template with specific requirements for each joint lab assignment.

While no additional formal cross-teaching occurred, throughout the quarter the CSC 448 instructor interacted with BIO 441 students as a group on several occasions, discussing specifics of some of the assignments. Additionally, the Teaching Assistant for CSC 448 (the third author) was present for all lab periods and worked actively with individual teams to bridge the gaps in communication whenever they arose.

Overall course flow. Both courses were successful in covering expected theoretical material in the time frame of the course. In CSC 448, the last week was originally planned for informal discussions of various bioinformatics problems not covered elsewhere in the course, but due to some lecture slippage, it was used to cover clustering as applied to multiple sequence alignment.

Fairly early in the course, we realized that strict code delivery deadlines were not enforceable, as a wide-range of post-deployment updates had to be made to the code by request of the BIO students. We adjusted our expectations, by introducing new assignments on original schedule, but allowing work on prior assignments to continue for a number of weeks after the initial deadline. For grading purposes, a deliverable from each team for each assignment was collected at some specific point, but *in an important distinction of this course from most other computer science courses, students continued working on the programs even after they were collected for grading*, as the final deliverables of their BIO partners were due only at the end of the quarter. The need to work on multiple software products at the same time added a level of stress (and certainly found its way into student comments), but it also added a touch of reality of working in a professional environment, where multiple tasks need to be juggled at the same time.

4. Evaluating the efficacy of *in-concert* teaching

We viewed the Spring 2012 offering as a pilot, designed to test the concept of *in-concert teaching* as applied to bioinformatics courses, and to illuminate our further efforts on improving these courses. To that extent, we were specifically interested in answers to the following questions:

1. *Are the students meeting the learning objectives of the courses?* Specifically, are the students acquiring the technical knowledge and skills taught in the courses (learning objectives 1-4 for CSC 448 and 1-3 for BIO 441).
2. *Are life sciences students acquiring computational skills?* The key computational skill presented in BIO 441 was the ability to convert a biological problem into a set of software requirements (learning objective 4 for BIO 441).
3. *Are students learning to work effectively with their peers within and outside of their discipline?* In particular, is there evidence that cross-disciplinary collaboration within the *in-concert teaching* framework is beneficial for the students? (learning objective 5 for both courses).
4. *How did students perceive in-concert teaching format?* Subjective satisfaction of students with their course may either help or significantly hamper their success with the course, often regardless of how well the students are actually meeting the course

learning objectives. The unusual format for the course presented some challenges to the students. It was important for us to understand what the students thought about the class format, and what, in their opinions, worked and did not work.

In the rest of this section we provide a brief overview of our efforts to evaluate, both objectively and subjectively, the answers to these questions. Except for question 2 which concerns primarily students from BIO 441, we stress the evaluation results obtained from the CSC 448 students.

4.1. Evaluation Overview

Our key evaluation instruments are three-fold. To evaluate overall student performance in the course – both for individual students and for student teams we use coursework grades. To evaluate the cross-disciplinary experience we conducted an exit survey for all CSC 448 and BIO 441 students in which we asked them to evaluate their work and the work on their peers on team assignments. Additionally, we asked open-ended questions about individual experiences in the course and about the major take home lessons from the course. Below we provide an overview of the observed results as they apply to the four questions specified above.

Question 1: Technical proficiency of CSC 448 students. Our only instruments in assessing the first four CSC 448 learning objectives were grades for various coursework. CSC 448 had paper-and-pencil midterm and final exams. The exams consisted of a variety of questions asking students to (a) apply algorithms covered in the course to solving instances of bioinformatics problems, (b) modify studied algorithms and techniques to adapt them to solving a specific bioinformatics problem and (c) craft simple multi-step solutions to bioinformatics problems out of existing “pieces”. Evaluation of individual CSC 448 learning objectives 1-4 on the basis of a specific problem or a set of problems from the exams is difficult, as the problems often combined elements of modeling and application. Instead, we group the objectives 1-4 into a single goal of “achieving technical proficiency with algorithms for solving bioinformatics problems.” We use the exam scores to evaluate the overall technical proficiency of individual students in the course.

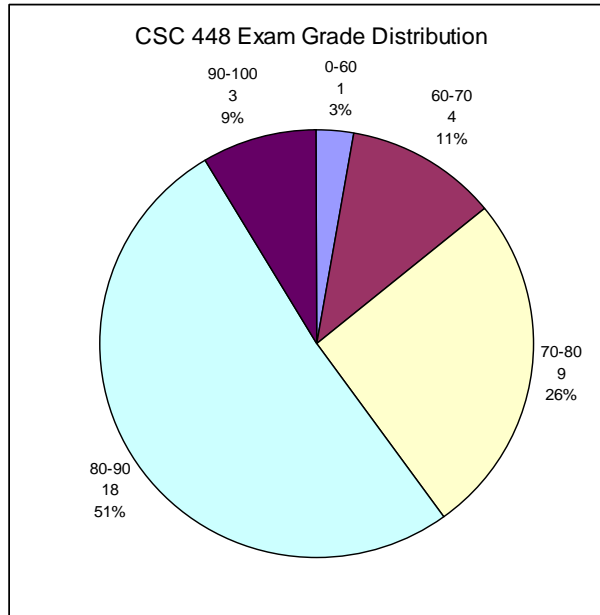

Figure 2. Distribution of normalized combined exam scores in CSC 448.

Two exams were administered: a 90-minute midterm and a three-hour final exam. The midterm was out of 75 points and the final exam was out of 100 points, with points on each exam having the same weight. Together, the two exams accounted for 50% of the course grade. The midterm exam, thus accounted for about 43% of the combined exam score or about 21.5% of the course grade, while the final exam accounted for about 57% of the combined score or about 28.5% of the course grade.

Figure 2 shows the distribution of the combined scores for the students in CSC 448 normalized to 100. An “A” range for the two exams was considered to be a normalized score of 80% or above. As seen from the chart, 60% of students (21 individuals) received a score of over 80%. An additional 26% had a score of 70-80% corresponding to a grade of “B”. Four students were in the “C” range (60-70), and one student had a score lower than 60%. A total of 86% of students in the course, therefore, displayed good or excellent technical proficiency as measured by the problem-solving on the exams.

Question 2. Can BIO students write good requirements? In the context of our courses, learning objective 4 of BIO 441 was met by introducing the notion of software lifecycle into BIO 441, and by giving students hands-on experience with participation in the software development process on almost all its stages. The computational skills we wanted to teach BIO students are the skills associated with development of proper software specifications. Throughout the course, BIO 441 students were required to produce five complete and formal requirements documents, one for each programming lab assignment (see Table 3).

We used the exit survey to evaluate this question. The exit survey was administered to both courses. The survey asked students a number of open-ended and closed-form (multiple choice or scaled answer) questions about what they considered to be their most important achievements in the course, about their experiences on the cross-disciplinary team, and about their advice for the

future course offerings. Some questions were different on the CSC 448 and CSC 441 surveys, asking students to look at the same thing from their specific perspectives. Some questions persisted across the course boundaries.

28 out of 35 CSC 448 students and 23 out of 24 BIO 441 students took the survey. At least one person from each team participated in the BIO 441 surveys. In the CSC 448 surveys, 11 out of 12 teams were represented by at least one student, with 10 of them represented by at least two. Because we wanted to link responses from students in each team together, the survey *was not* anonymous.

The survey included two questions for evaluating the quality of requirements documents written by BIO 441 students. The CSC 448 survey’s questions were:

1. *How would you rate (overall) the requirements documents provided to you by your BIO 441 partners?*

We used the 0-5 scale for the question with 0 being “requirements documents completely lacking,” and 5 being “excellent.”

2. *Did the requirements documents get better as the quarter proceeded?*

We used the 0-5 scale for the question, with 0 being “no basis for judgment”, 1 – “document actually decreased in quality”, 2 – “no clear pattern”, 3 – “quality stayed the same”, 4 – “slight improvement” and 5- “got much better”.

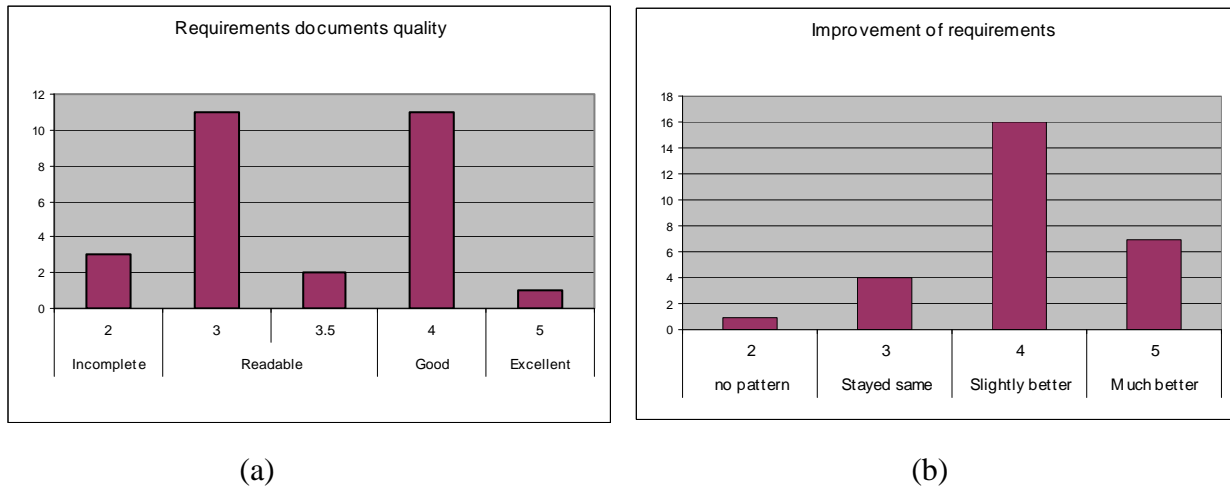

Figure 3. Peer assessment of quality of requirements documents (a) and the level of improvement of the requirements documents over the course of the quarter (b). CSC 448 students assessing BIO 441 students.

Figure 3.a shows the summary of the responses to the first question. Only three CSC 448 students stated that requirements documents provided to them throughout the quarter were incomplete and otherwise lacking in quality. The vast majority of the class split evenly between the requirements documents being “readable” and usable, and between the requirements documents being “good”. The average score on this question was 3.4 with the standard deviation of 0.72.

Figure 3.b shows the summary of the responses to the second question. Only one student indicated that the quality of the requirements documents fluctuated over the course of the quarter (incidentally, this was also one of the students who gave a score of 2 for the previous question). Four students stated that the quality stayed the same. The remaining students indicated an improvement of the quality of the requirements documents over time: 18 students indicated slight improvement, while seven students indicated significant improvement. Overall, 82% of CSC respondents indicated that the quality of the requirements improved. This aligns well with the self-assessment of BIO 441 students: 86% of them, in response to a different survey question indicated that their ability to write program requirements improved over time.

In drawing our conclusions about the efficacy of biology majors translating bioinformatics programs into formal software requirements specifications we rely on the opinion of their computer science partners. There are two possible threats to validity that may affect our overall evaluation. First, CS students are asked to evaluate their peers with whom they worked closely for the duration of the quarter. As such, they may be uncomfortable reporting their real opinions, especially in the situation where we know whose requirements documents they are supposed to evaluate. To a large degree the scores provided by the CS students reflect their level of comfort working with their BIO partners as well as their assessment of the requirements documents. We are comfortable with this evaluation for the pilot study, but will use more objective instruments for evaluation in the future. The second threat to validity comes from the fact that students are unreliable judges of quality of software engineering artifacts and that the grading scales of individual students may have been different – i.e. two different students assigned different numeric scores, while holding the same qualitative opinion of the requirements documents. This threat is present in any assessment that relies on peer evaluation though. In our case, we view student-assigned scores as the evidence of their personal perception of the difficulty of understanding the requirements documents provided.

Question 3: How well did the teams work together? The exit survey contained a group of questions designed to gauge the participation of BIO 441 students in the software development process and the level of their engagement. CSC 448 students were asked:

- *For each step of the software development process shown below, indicate the extent to which **your BIO 441** partners contributed.*

BIO 441 students were asked:

- *For each step of the software development process shown below, indicate the extent to which **you and your partner from BIO 441** contributed.*

Both classes were provided with the same list of steps: *Requirements, Design, Development, Testing, Deployment, Maintenance*. The response scale was 0 – 5, described as shown in Table 4 below:

Table 4. Response scale for the question about level of participation of BIO 441 students in the software development process.

Value	Meaning
0	Did not contribute at all
1	Contributed very little
2	Minor contributions
3	Significant contributions

4	Same level of contribution as CSC 448 partners
5	Were team leaders

Student responses are summarized in Figure 4 and Table 5. As seen from the collected data, students from both courses agreed that there was a distinct contribution from BIO 441 students in the requirements and testing stages of the lab assignments. CSC 448 students reported diminished contributions on the design stage. Deployment stage was characterized by large diversity involvement of BIO 441 students – they were making large contributions on some teams, but not contributing on others (hence the largest standard deviation of all stages). Most CSC 448 teams agreed that BIO 441 student contributions on the development and maintenance stages were not very significant.

Compared to their CSC 448 peers, BIO 441 students tended to be more optimistic about the value of their contribution to the joint work, overstating their contributions by about one point on the 0-5 point scale (the average difference between CSC 448 and BIO 441 evaluations is 0.96). This bias was expected. The differences of opinion were smaller on the stages where BIO 441 students participated more actively, and larger on the stages where their participation was not as widely acknowledged. Only one stage, deployment, showed a significant disagreement between the two courses.

Overall, the results paint a clear picture of how the collaboration process worked, and the picture aligns well with our expectations. As expected, the core interactions in the teams happened at the beginning of each lab, while requirements were discussed. We expected the contributions of BIO 441 students to be minimized during the design and development stages, and were hoping that they would come back for testing. Our hopes found cautious justification in the student responses, as we saw the contributions of BIO 441 students increase significantly at that stage. From there on, different teams chose different paths to proceed, with some teams continuing to work tightly on the deployment and maintenance of the programs, while other teams essentially not having significant post-delivery interactions concerning the software.

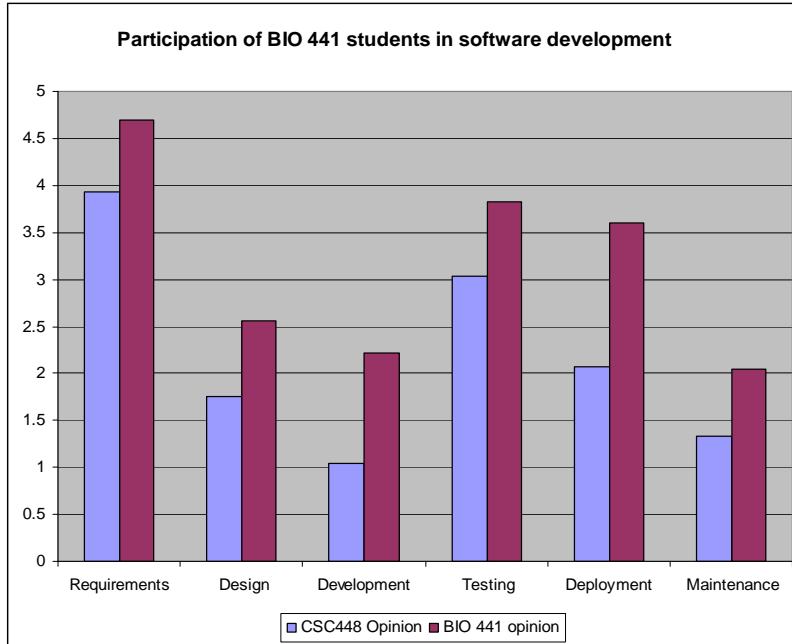

Figure 4. Participation of BIO 441 students in different stages of the software development process, as reported by CSC 448 students and BIO 441 students themselves.

Additional survey questions were used to assess student perception of the outcomes of their collaborative work. A pair of questions asked the students to specify if their confidence in their ability to work effectively with colleagues in their discipline and outside of their discipline has increased. Table 6 shows the information about the percentage of respondents in each class who indicated that their confidence has either increased somewhat or increased significantly. As seen from the table, solid majorities in both classes (but especially in BIO 441) indicated that they are more confident in their ability to work with people from outside of their discipline.

Table 5. Participation of BIO 441 students in different stages of the software development process, as reported by CSC 448 students and BIO 441 students themselves.

Stage	CSC 448		BIO 441		Difference
	Mean	St.Dev	Mean	St.Dev	
Requirements	3.92	1.05	4.7	0.63	0.77
Design	1.75	1.26	2.56	1.31	0.815
Development	1.03	1.29	2.22	1.25	1.18
Testing	3.03	1.48	3.82	0.82	0.79
Deployment	2.07	1.89	3.6	1.09	1.528
Maintenance	1.33	1.38	2.04	1.46	1.46

Table 6. Student confidence in their ability to work with colleagues.

Increased confidence in ability to work with colleagues	BIO 441 students	CSC 448 students
In own discipline	62%	75%
Outside of own discipline	86%	68%

One more survey question asked “*What are the three most important things you learned in this course?*” The most popular responses to this question for the students from CSC 448 and BIO 441 are summarized in Tables 7.a and 7.b respectively.

Table 7. Most popular responses about the most important things learned in the class for CSC 448 (a) and BIO 441 (b) students.

(a)CSC 448

(b) BIO 441

Response	Number (out of 28)	Percent	Response	Number (out of 23)	Percent
Algorithms	16	57%	Genome annotation	18	78%
Work with non-CS teammates	14	50%	Work with CS teammates	12	52%
Teamwork	8	25%	Concepts related to genes	11	48%
Suffix trees	6	21%	Software requirements	5	23%
Communication	5	18%	Research/data analysis	4	17%

Student responses in both classes paint a clear picture. In both courses, technical knowledge in own discipline – bioinformatics algorithms, and genome annotation and the science of genomics, were the most popular answers. However, work with teammates outside of their discipline came in second in both courses, with about half of students in each class naming *explicitly* not just the teamwork aspect, but also the *collaboration outside the discipline* aspect. In CSC 448, an additional 13 responses mentioned teamwork and communication, without specifically addressing cross-disciplinary collaboration. When combining student responses, 23 out of 28 CSC 448 students (82%) mentioned algorithms (generic or specific) in their response. What is interesting, is that almost the same number, 22 students (78.5%) mentioned at least one thing that alluded to Learning Objective 5 (collaborative work). We conclude from this data that students in both classes, but especially CSC 448 students found their experience of working on a cross-disciplinary team throughout the entirety of the course to be its key component.

Question 4: What did the students think about their experience? A number of questions on the survey were designed to elicit open-ended responses. We asked students to describe the benefits of working on cross-disciplinary teams, explain what challenges they encountered in coursework and how they overcame the challenges, and let us know what they liked the most about the course and what could be improved. A representative sample of comments by the CSC 448 and BIO 441 students is included in Appendix A.

A reading of the comments of CSC 448 students revealed, that almost uniformly, regardless of their prior expectations about the course, and regardless of the actual achievement of their teams on joint assignments, and specific experiences with their teams, *students understood the*

importance of working with peers from other disciplines and appreciated the opportunity to do so throughout the quarter. Some of the most encouraging and positive comments came from students whose teams struggled the most throughout the quarter. Course critique and suggestions for improvement were, for the most part, well thought-out and based on actual in-class experiences.

5. Lessons Learned and Future Improvements

As evidenced by the student comments (see Appendix A), teaching bioinformatics *in-concert* was challenging, and not everything in the course went smoothly. Below we list and discuss some of the challenges we and the students encountered.

Heterogeneity of student body. The prerequisites for both courses were historically kept relatively low: CSC 448 required CS III (Data Structures) as the only prerequisite, while BIO 441 required only an introduction to biology course. In BIO 441 it resulted in a number of students from outside of life sciences majors taking the course. In CSC 448, some students taking the course took neither algorithms nor software engineering coursework. Some Computer Engineering majors took this class after almost a year-long break from CS coursework, which affected their programming skills. This meant that the experiences and the knowledge of some of the students in each course were in conflict with the key idea behind *in-concert* lab assignments: that students from each class will play the roles of experts in their discipline. In a small number of teams, this issue existed on both sides, and these teams experienced more difficulties in organizing software development process.

CS lab deliverables. In response to concerns of some students, expressed prior to the beginning of the course, that their grade may depend fully on students from another course, CSC 448 lab assignments were designed with two deliverables in mind: a deliverable for BIO 441 students, which had to run and produce results needed for the research project, and a deliverable for CSC 448, which typically included a generic implementation of an algorithm or data structure discussed in the lectures (and was supposed to be the basis of the BIO 441 deliverable). The lab grade was based on both deliverables.

However, it turned out that the fears of grade dependence on outsiders were *premature* – no student in the class ever complained about it. At the same time, the dual deliverable policy caused a lot of confusion among the students and resulted in significant deadline slippage throughout the course. One of the strongest suggestions received from CSC 448 students was to require only the BIO 441 deliverable.

Deadline slippage. Perhaps the biggest lesson learned is that software is never complete. BIO 441 students continued using the code developed by CSC 448 students throughout the entire quarter, which meant that even the second-week assignment, a simple GC% computation program was still in active use around week 9 of the course. Additionally, as more pieces of the course-long project were developed, revisions to older programs were requested to make the inputs/outputs of deliverables from different labs match. This meant that by the second half of the quarter, each team was working on different stages of 3-4 programs at the same time. This,

and the abovementioned confusion about the nature of some deliverables led to teams being unable to complete initial code delivery for labs on the original deadline dates.

Lack of cross-teaching. Two more common comments we received from students indicated that BIO 441 students had trouble writing requirements that properly reflected their assignment, and CSC 448 students struggled at times to understand the nature of the assignment itself. We identified lack of cross-teaching as the underlying reason for both of these comments. BIO 441 students received some instruction on software development process and requirements at the beginning of the course, but no further cross-teaching interactions occurred. Similarly, CSC 448 students only communicated with their team partners on the matters related to the specific nature of the assignments, and whenever their partners struggled to explain the assignments, confusion arose.

At the same time, even with the significant challenges described above, we believe that the courses largely served their purpose. We showed that *in-concert* teaching format is feasible and is accepted by students. We observed student achievement with respect to every learning objective in both classes, and we specifically observed significant achievement associated with the new learning objectives in BIO 441 (writing requirements, working with CS peers) and the matching learning objective in CSC 448. Students *bought into the concept of the courses* even when their individual experience was imperfect.

The next offering of both classes is scheduled for Spring 2013 quarter. We plan to organize the courses logistically in the same way, and admit 12 five-person teams worth of students in both classes (24 BIO + 36 CS). We are actively revising some aspects of the courses to take into account the issues discussed above. In particular, the following course changes and improvements are planned:

- **Tighter enrollment control.** We plan to limit enrollment in BIO 441 to life sciences majors with significant biology background to ensure that they can successfully assume the role of experts in their field. Similarly, we plan to raise expectations for computing sciences majors enrolling in CSC 448.
- **Streamlined lab assignments.** All lab assignments will have only one set of software deliverables – the programs required by BIO 441 students. We will establish a two-tier submission process, where an early version is submitted on a short deadline, but the final version of each program is due during last two weeks of the quarter. Grading policies will be adjusted accordingly.
- **More cross-teaching.** A series of lectures on software engineering for BIO 441 students by the CSC 448 instructor is planned. We expect to have 30 minutes to 1 hour of cross-teaching time per week for the first 6-7 weeks of the quarter. The time will be used to discuss software development process in more detail, provide hands-on experiences with requirements specification and test case development, as well as address any questions BIO 441 student might have about the labs and collaboration with CSC 448 students. We plan to adjust the lab assignments so that each subsequent assignment emphasizes the participation of BIO 441 students in one of the steps of the software development process: requirements, design (data modeling), testing, deployment and maintenance.

During the same time, BIO 441 instructor will conduct more in-depth discussions of biological topics with CSC 448 students.

With the commitment of both Biology and Biochemistry and Computer Science programs at Cal Poly, the *in-concert teaching* of bioinformatics is slated to become an annual staple.

Acknowledgements

This work is supported in part by a grant from the W.M. Keck foundation.

Bibliography

1. Genomics Education Partnership, <http://gep.wustl.edu/>.
2. Computer Science Unplugged, <http://csunplugged.org/>.
3. G.A. Amoussou, M. Boylan, Joan Peckham, Interdisciplinary Computing Education for the Challenges of the Future, in *Proceedings, ACM SIGCSE' 2010*, pp. 556-557, 2010.
4. M. Fellows, M., T. Bell (2010) *Computer Science Unplugged*.
5. K. Forsberg and H. Mooz, The Relationship of System Engineering to the Project Cycle, in *Proceedings of the First Annual Symposium of National Council on System Engineering*, October 1991: 57–65.
6. Lopatto D, Alvarez C, Barnard D, Chandrasekaran C, Chung H-M, Du C, Eckdahl T, Goodman AL, Hauser C, Jones CJ, Kopp OR, Kuleck GA, McNeil G, Morris R, Myka JL, Nagengast A, Overvoorde PJ, Poet JL, Reed K, Regisford G, Revie D, Rosenwald A, Saville K, Shaw M, Skuse GR, Smith C, Smith M, Spratt M, Stamm J, Thompson JS, Wilson BA, Witkowski C, Youngblom J, Leung W, Shaffer CD, Buhler J, Mardis E, Elgin SCR., Education Forum: Genomics Education Partnership, 2008, *Science* 322, 684-5
7. Pevzner P, Shamir R., Computing has changed biology--biology education must catch up, *Science*. 2009 Jul 31;325(5940):541-2.
8. Tyler, R. . *Basic Principles of Curriculum and Instruction*. Chicago: University of Chicago Press, 1949.
9. Wiggins G, McTighe J. *Understanding by Design*. 2nd ed.. Alexandria, Va: Association for Supervision and Curriculum Development, 2005.
10. Wiggins G, McTighe J. *The Understanding by Design Guide to Creating High-Quality Units*. Alexandria, Va: Association for Supervision and Curriculum Development, 2005.
11. Maureen Lage, Glenn Platt, Michael Treglia. Inverting the Classroom: A gateway to Creating an Inclusive Learning Environment, *Journal of Economic Education*, 2000.
12. Julie Foertsch, Gregory Moses, John Strikwerda, Mike Litzkow (July 2002), Reversing the Lecture/Homework Paradigm Using eTEACH Web-based Streaming Video Software, *Journal of Engineering Education*, 7/ 1/2002, Vol. 91 Issue 3, pp. 267-286, July 2002.

Appendix A.

We include a sample of comments made by students from CSC 448 and BIO 441 in response to open-ended questions in the exit survey.

CSC 448.

Question: *What did you like best about the course?*

“Working on meaningful code that another discipline can use for research. It was rewarding and a valuable experience.”

“The course is fast paced. I felt like I learned a good amount.”
“The way the lab period was structured...”
“I liked that we got to work in teams with non-CSC majors. It was a fun experience.”
“Having a real research project.”
“Writing programs that actually had practical use.”
“Multi-discipline [sic] groups... Real-world experience.”
“It was fun. I really enjoy group work and that is all this was.”
“I liked that we were doing something with significance to a developing field.”

Question(s): *What can be improved in the course and how could it be improved? What can the instructors of both courses do to help students overcome the challenges better?*

“It was hard to complete some projects on time ...”
“Spend a little more time so the BIO students know what they need/want better. Program requirements were often incomplete or wrong from what they actually want [sic]. Obviously, this can never be completely avoided, but it can be reduced.”
“Work towards a single ‘tool’.”
“Reduce complexity of some labs.”
“Help CHEM students understand how to explain problems more clearly...”
“Proofread requirements. Allow time ... for BIO students to test the program.”
“Testing... Sometimes it’s hard for CS students to see a problem with data.”
“Make it perfectly clear what needs to be turned in [for BIO 441] and what for [CSC 448].”
“...the flow of communication was the biggest issue.”
“More preparation of test cases for CS student to use during development.”
“Require more communication before building software.”
“Meh, suffering is how we all learn best.”

Question: *“What were the benefits of working with partners from a different discipline?”*

“You do that in the real industry so you get a head start. You get a break from all-CS partner teams.”
“They could help fill in the blanks when we did not understand what they needed.”
“You learn to really work with subpar or unclear prog[ram] requirements.”
“Understand how to handle knowledge gaps/barriers.”
“Learned how to get requirements from people who don’t understand them.”
“Got to work on programs that go towards real use. Meet people outside the major.”
“We get their domain knowledge and they make decisions about what they want the software to do.”
“If you have to explain/teach others how to do something, you end up with a better understanding.”

Question: *“What were the challenges/drawbacks of working with partners from a different discipline?”*

“They didn’t know exactly what they needed/wanted often.”
“We were both learning so it was hard to explain if we didn’t understand how things went.”

“They didn’t fully understand what were capable of doing and we didn’t always understand the [bio]chemistry concepts.”

“Having to teach basic knowledge of own discipline.”

“Time management. Things they thought were quick problems weren’t.”

“They didn’t have any experience writing spec documents before.”

“You have to swap back and forth between different mindsets quickly.”

“...getting the program to work the way they wanted.”

Question: *“If you overcame challenges, how?”*

“By communicating ... and programming late at night.”

“We eventually learned how to speak the same language...”

“We used to finish programs early so bio partners can help us to verify results, give us feedbacks[sic].”

“Constantly calling, texting or meeting up.”

“We did it by staying in close communication with CHEM students on our team.”

“By redeveloping software at first. Later by making sure their requirements were correct.”

“Frequent conversations with our CHEM partners. Calling them late at night.”

“We overcame them by failing to give them what they wanted at first, so they figured out how to explain to us what they needed.”

“We showed them how to give us useful specifications.”

BIO 441.

Question: *What were the benefits of working with partners from a different discipline?*

“Learning how different we think from each other and how to communicate more effectively”

Question: *“What were the challenges of working with partners from a different discipline?”*

“Really the same as the benefits...differences in background knowledge and communication.”

“They had little/no prior knowledge of the concepts, so everything had to be very clear and precise while also very detailed.”

“They didn't know what we wanted, and we didn't know the extent of what they could do.”

Question: *If you overcame the challenges, how?*

“Dogged determination, sacrifice, and communication efforts/skills got us through. When these failed, we failed.”

“Learning to speak up when something is not correct on either side of the team and trying to teach each other bits of background info ...”

“By trying to fully understand the information before communicating it to CS partners.”

“We had to discuss frequently and rewind our explanations until they made sense.”

Analysis of Aerospace Engineering Students Who Repeat Degree Requirements

David B. Lanning Jr.
Embry-Riddle Aeronautical University, Prescott, Arizona

Abstract

This work investigates enrollment statistics, cumulative grade-point averages (GPA), and overall success of a cohort of undergraduate aerospace engineering (AE) students who repeated required courses during their academic studies at Embry-Riddle Aeronautical University. Students retake courses that they do not pass, or sometimes retake courses to improve upon their prior grade to raise their cumulative GPA. It has been informally observed that a number of students manage to persist in the degree program by retaking courses many times, too many times in the eyes of many of the engineering faculty. These students often manage to maintain an acceptable although often inadvisably low GPA, and harm their chances of success beyond graduation. The Department of Aerospace and Mechanical Engineering (AE/ME) is currently considering various alternatives to raise the bar on certain degree program requirements, such as limiting the number of attempts a student may make at completing a required course. For the purpose of tailoring any new degree program requirements to ensure student success both during their undergraduate engineering education and after graduation, this work focuses on identifying students who repeat courses and provides data on the number of courses repeated, improvements upon prior attempts, cumulative GPA, and graduation rates. These data and analyses are intended to aid in the deliberations on degree program requirements during the next several years.

Introduction

It is incumbent upon any long-time faculty member to assess the state of the student body in dismal terms and to make sweeping pronouncements as to the current decline in undergraduate ability, as compared to the days of yore. Nods of agreement emanate from all walks of the professoriate. But, the required self-study is often not initiated in an attempt to verify such speculation.

The author of this study and a majority of the faculty in his academic department frequently comment on the high number of students repeating required courses in the degree program. And, many seem to agree that a problem exists with numerous students not looking upon the prospect of failing a course and repeating it with the proper shame and horror that should accompany such an event. Occasional glances through advisees' transcript during times of course registration and academic planning reveal the extent to which this has occurred. For years, the faculty has discussed stiffening graduation requirements in an effort to help students understand that needing to repeat a course should not be taken lightly. However, a variety of obstacles to substantial changes often present themselves, and the faculty wonders whether the effort of proposing and implementing such changes is truly worthwhile. It is in this frame of mind that the author

undertook an investigation to find out how widespread are course repeats, and to use this information to enable sound academic planning.

Embry-Riddle Aeronautical University, Prescott campus

The Prescott, Arizona campus of Embry-Riddle Aeronautical University (ERAU) is a primarily undergraduate institution with an enrollment of close to 1700 students. It is a private university, with an annual tuition of around \$30,000. The College of Engineering includes the largest department, the Aerospace and Mechanical Engineering Department. The official tally of aerospace engineering (AE) students was 534 in Autumn 2012 and the number of mechanical engineering (ME) students was 96. Therefore, the department is responsible for over one-third of all students at the campus.

The engineering student body is composed exclusively of undergraduate students. The department strives to provide strong student-faculty instruction and mentorship, significant design experiences, and a hands-on learning environment. Engineering laboratories with extensive space in which students can work are a feature¹.

While the entire campus takes pride in the degree programs and various opportunities available at our campus, our small size may have some drawbacks for a subset of students due to the specialized nature of our “Aeronautical” University. Those considering leaving a degree program such as engineering have a limited menu of degree programs from which to choose if they hope to remain at Embry-Riddle. Knowing that close bonds form between friends during academic study, especially at small campuses, students may persist in an academic program longer than they might otherwise because of a lack of degree options of potential interest.

Methodology

To investigate the course repeat rate of a group of engineering students, a cohort of moderate size was selected. The ME program is relatively new to the Prescott campus of ERAU, so students in the AE program were chosen. A cohort of 172 students was selected, those who enrolled in ERAU at the Prescott campus as incoming freshmen in the AE degree program during the Autumn 2007 semester, and were enrolled in the UNIV 101 College Success course. This course is a one-credit hour introduction to college life and the Embry-Riddle programs, services and opportunities. This served as a convenient tool with which to select this cohort of freshmen. No transfer students were included, at least those with significant transfer credit and who elected to not enroll in UNIV 101. This cohort was selected to better understand the freshman student who plans to spend nearly four year (or longer) in the ERAU engineering degree program. The Autumn 2007 semester was chosen to obtain a group of students who would likely be graduated, or close to graduated, by the end of the Spring 2012 semester. Finally, this would be a group of students still well-remembered by the faculty, who could lend some qualitative information to an analysis of the cohort.

The author obtained all the data by combing through the transcripts for each student. At the time, ERAU was transitioning to a new student data management system, Oracle’s PeopleSoft Campus Solutions, and no easy or robust method for data mining was available to the author (nor

is there still, as far as the author is aware). So, the brute-force, long-form technique of obtaining data from individual records, bit by bit, was implemented. It should be emphasized that while the author strove to be accurate, the results in this student should be treated as estimates.

The following results are as of August 2012. The author of this work recognizes that what follows in this paper is a veritable assault of data, which might overwhelm the mildly interested reader. But, for those readers sufficiently curious about this topic, each table and figure has additional clues to the behaviors of our students, the sum of which tells an interesting story.

Graduated students

One of the first results to report for this AE student cohort is the graduation rate, shown in Table 1. Of the 174 student cohort, 19 students were still at ERAU as of August 2012 (around half of these graduated in December 2012). The graduation percentage of around 42% is not atypical of the graduation rate in engineering at many universities, when considering that most of the current students (14) will also make it to graduation. These results include several AE students who switched majors from AE to ME. Since the ME degree program is in the same department, and the switch does not represent a drastic change on the part of the student, the author is not including them in the group that has switched majors.

Table 1: Graduate rate for AE cohort

<i>Total cohort</i>	<i>174</i>	
Graduated in AE or ME	74	42.5%
Current in ERAU in AE/ME	14	8.0%
Grad. ERAU in another major	18	10.3%
Current in ERAU in another major	5	2.9%
Left ERAU	63	36.2%

One can see that the attrition rate of students leaving ERAU is not small, a little greater than one third of the cohort. While exit interviews are performed by the academic advisors to help understand why the students left the university and ask where they plan on going, those results are not the focus of the current work and the issue is not addressed further. These attrition rates in engineering are not broadcast to freshman students by a majority of the faculty, in the author's experience, but many students realize that engineering is a difficult program of study, and there is not an attempt to hide the fact that some students will decide to do something else.

Table 2 shows the number of semesters the graduated students attended ERAU. Many of our students attend classes during the summer, and this is indicated. The left column shows the number of regular semesters (i.e. autumn and spring semesters), while the additional columns include the number of summer terms the student attended. It is important to realize that a typical summer term will not include as many courses as a typical autumn or spring semester, since the summer sessions are accelerated six and seven week terms. Most students take one or two classes during a summer term; three courses would be considered a heavy load for a summer term.

Further, Table 2 does not include transfer credits (including credit from AP exams) these students brought with them to ERAU. This is of interest and may be investigated by the author at a later date. But, since these students came to ERAU as freshmen in 2007, and enrolled in the College Success course as a way of adapting to the new change of university life, it will be assumed that the influence of transfer credits is somewhat modest on the current study. A majority of these students have just a few classes transferred, often through AP credit, upon matriculating to ERAU.

The notable conclusion from the table is that a minority of students complete the degree program in just eight regular semesters. And, many of our students elect to take classes during the summer.

Table 2: Semesters at ERAU to graduate for graduated students

Regular semesters	Summer semesters					Row total
	0	1	2	3	4	
7	2	0	1	0	0	3
8	14	7	10	4	0	35
9	6	4	4	1	4	19
10	6	5	4	2	0	17
Column total	28	16	19	7	4	

Figure 1 shows the cumulative GPA (grade point average) of these 74 graduated AE or ME students from the cohort of 174 students. The average cumulative GPA is around a 3.0. Since one of the ERAU graduation requirements is that students have a cumulative GPA of greater than 2.0, there is none below a 2.0 on this chart. An additional graduation requirement is that students have a minimum GPA of 2.0 in their major, which might be viewed as too low by some faculty.

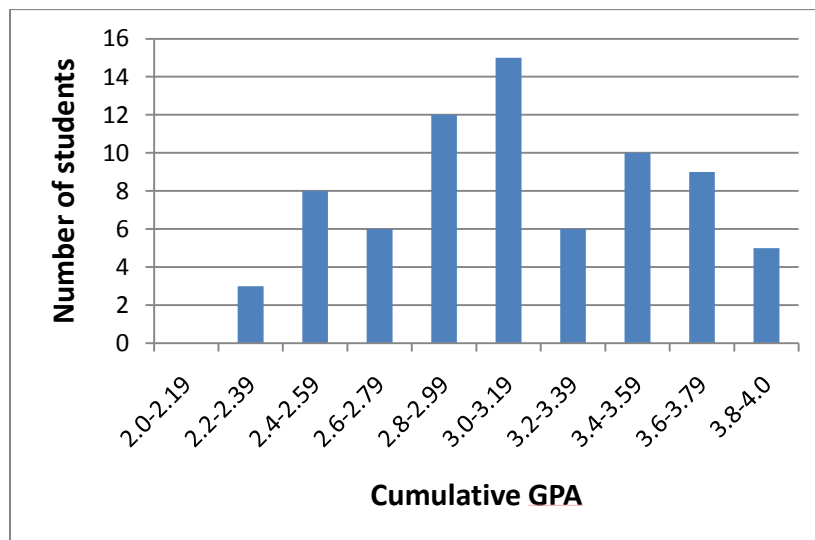

Figure 1: Cumulative GPA for graduated students.

Figure 2 shows the number of repeated courses by these graduated students. Only 23 students completed the AE or ME degree program without repeating a course. This does not include any transfer courses, although it does include courses they may have taken at the other ERAU campus in Daytona Beach, Florida (ERAU has two residential campuses). Also, a repeated course includes not only students repeating a course to improve upon a grade received the first time, but includes instances where a student has a Withdrawn or Audit on their transcript. This means they switched their status from graded to non-graded after the third week of classes during the regular autumn or spring semesters and after the second week of summer terms. The author assumes that a majority of the Withdraws and Audits are from students who have done poorly during a significant portion of the semester, and felt it in their best interest to change their status in the course lest they receive a poor grade.

Of particular concern, certainly, is that a sizable number of students repeated a fairly large number of courses, three or four and above. As a student repeats more and more courses, it is easy to wonder whether or not they are doing themselves a service remaining in an engineering program. Certainly, there is a correlation between their GPA and the number of courses they have retaken, although this correlation is not shown here. There is no limit to the number of times a student can repeat a course, although after three repeats, the old grades start to be included in the cumulative GPA calculations.

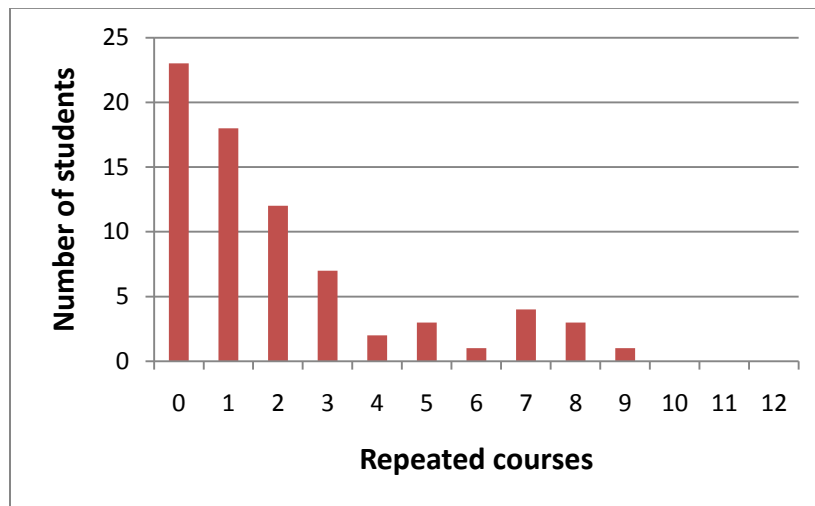

Figure 2: Number of repeated courses by graduated students.

This study includes any course repeated at ERAU, and not just the AE or ME major courses. But, it is mostly the technical courses in which the students struggle. Table 3 shows which courses are being repeated. The reader is referred to the ERAU student catalog² for a full accounting of the identities of these classes. Some interpretation without the catalog on hand can be gained by knowing that MA represents math, PS is primarily freshman and sophomore physics, AE are various aerospace engineering courses, and ES indicates engineering sciences (ES 201 = statics, ES 202 = solid mechanics, ES 204 = dynamics, ES 305 = thermodynamics). It is during the sophomore and the beginning of the junior year that students appear to struggle the most. And, the total of 153 repeats between these 74 graduated students is not a small number!

Table 3: Courses repeated by graduated students

<i>Class</i>	<i>Repeats</i>
ES 204	26
ES 202	23
AE 304, ES 305	10
AE 313	8
MA 241	7
AE 404, MA 441	6
ES 201, MA 243, PS 160	5
EE 335	4
AE 301, AE 430, EGR 115, ES 320, MA 242, MA 345, PS 150	3
CEC 220, ES 206, ES 321	2
AE 302, AE 314, AE 315, AE 413, COM 221, EGR 200, EGR495A, AE 326, AE 408, MA 412, AE 495R	1
Total	153

Valuable insight can be gained by examining the success of students retaking courses. To this end, there are multiple ways for presenting the data. Table 4 shows how many times a student repeated a *particular* course. So, there were ten instances of a course being repeated twice. For example, a student may have repeated Solid Mechanics twice, meaning they enrolled in the course a total of three times. Again, this includes Withdrawns and Audits on their transcript. And, for instance, one “double repeat” counts for two (2) of the 153 total repeats for this cohort. Most of the graduated students only had to repeat a course a single time to consider their achievement either a success or at least adequate.

Table 4: Number of times a course was repeated by graduated students

<i>Repeats for one course</i>	
Single repeat	127
Double repeat	10
Triple repeat	2
Quadruple repeat	0

It is also instructive to examine the outcomes of each course retake in terms of the improvement from the first attempt. Table 5 provides these details, showing both the original grade and the new grade. Here, the original grade is the mark in the transcript just prior to the retake. So, if a student took a class a total of three times, receiving an F and D and C consecutively, the D is the “original” grade for the second time the student retook the class. A “W” indicated a Withdrawn mark on the transcript, and “AU” indicates the student audited a class. It should be noted that almost no engineering student ever audits a required course for the sole reason of preparation in advance of the time they take the course for an actual letter grade. The audit typically comes about from students who are doing poorly and need to remove the course as a graded event, but still want to attend class and listen to the lectures. Also, some students may feel an Audit mark looks better on their transcript than a Withdrawn.

Table 5: Original grade versus new grade for repeated courses, graduated students

Original – new grade	Occurrences	Original – new grade	Occurrences	Original – new grade	Occurrences	Original – new grade	Occurrences	Original – new grade	Occurrences
F - AU	0	D - AU	0	C - AU	1	W - AU	0	AU - AU	1
F - W	0	D - W	1	C - W	1	W - W	0	AU - W	1
F - F	5	D - F	1	C - F	0	W - F	0	AU - F	2
F - D	7	D - D	4	C - D	0	W - D	2	AU - D	7
F - C	16	D - C	11	C - C	0	W - C	8	AU - C	9
F - B	13	D - B	21	C - B	4	W - B	8	AU - B	7
F - A	4	D - A	5	C - A	4	W - A	4	AU - A	3
total	45	total	43	total	10	total	22	total	30

There is a lot of information in Table 5. It should be noted that a D is considered passing at ERAU for most classes, but not all. Students must receive a C or higher in Calculus 1 and 2 (MA 241 and MA 242) and Physics 1 (PS 150) before moving on to ES classes, and the same for entry into AE classes with the additional requirement of a C or better in Physics 2 (PS 160). There are a few students who retake courses in which they received a C to improve their grade and bring up their GPA. Also, there is a single B to A course retake that is not shown in Table 5.

An important use of Table 5 is the examination of how successful the students were in improving upon the prior grade. This information is distilled in Table 6, which gives the amount of improvement in terms of increase (or otherwise) in the letter grade. Marks of W and AU are treated as F for the initial grades in this table, and as “No improvement” for final grades.” One might argue about what is to be considered a success, of course. Receiving a passing grade to replace a failing grade might certainly be a measure of success. But, the author believes that a single letter grade improvement should be viewed as somewhat disappointing for a student who has seen much of the course material twice. Therefore, the author will claim that any result less than receiving at least two letter grades for improvement is something less than successful, and this comes to 49 out of 151 retakes; about 1/3 are not successful in the author’s view.

Table 6: Grade improvement upon retaking courses

<i>Improvement</i>	
Negative one letter grade!	1
No improvement	16
Positive one letter grade	32
Positive two letter grades	58
Positive three letter grades	33
Positive four letter grades	11

Finally, it should be noted that all required courses in the AE degree program are taught every autumn and spring semester, and sometime during the summer terms. Therefore, and student needing to repeat a required course does not have to wait a full year to retake the course.

Current students (as of August 2012)

The next cohort group is of those students still enrolled at ERAU (as of the end of Summer 2012). This group consists of 14 students out of the initial 174 students. One might expect that this group of students consists primarily of those either enrolled in more than one major and those who have languished in the AE or ME degree programs, having just enough success to not be dismissed permanently from the program. After viewing the data, the reader will realize that the latter is the typical situation with these students.

This separation between graduated students and current students has a logic beyond graduated versus current. This cohort started at ERAU in 2007, and the end of Spring 2012 marks the five-year point. In the author's view, a case can be made that nearly any engineering student should be able to obtain his or her degree within five years, under normal circumstances. So, examining the difference between students completing a degree within five years and those requiring longer to graduate may be useful for understanding those students with potential serious difficulties.

Table 7 provides an overview of the number of semesters these students have spent at ERAU. The students who have not attended any summer classes are shown under "0" summer semesters. It can be seen that almost all of these students have attended at least one summer term.

Table 7: Semesters at ERAU for current students

	<i>Summer semesters</i>						
Regular semesters	0	1	2	3	4	5	6
9	1	0	0	0	0	0	0
10	0	4	5	2	0	1	1

Figure 3 provides the cumulative GPA for the current students. Only one has a cumulative GPA above 3.0, which is not good. The average GPA is below a 2.5, which indicates that these students have poorer prospects of obtaining a good engineering job after graduation. These GPAs can be compared to those in Figure 1 of the graduated students in the cohort, and there are significant differences.

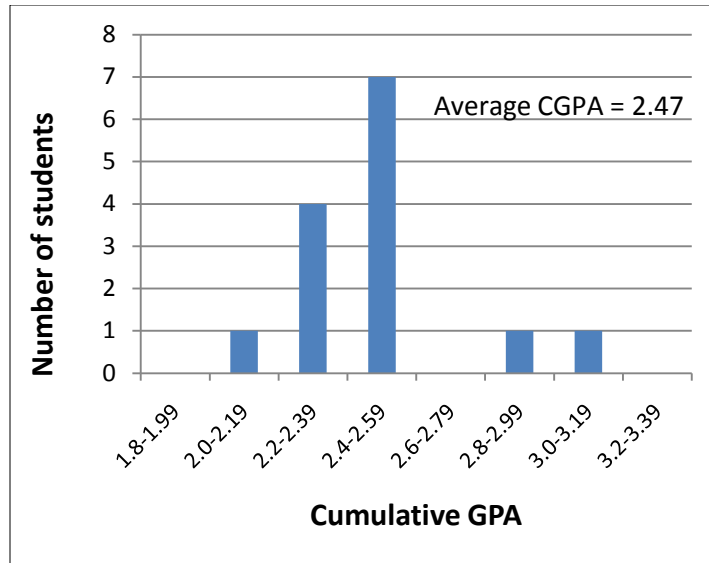

Figure 3: Cumulative GPA for current students.

Figure 4 provides the number of repeated courses for these fourteen students. There are no students who did not have a repeat a course, and the average number of courses repeated is greater than 10. One student has an absolutely astounding 20 repeats (and counting?), and has somehow managed to persist. To further place this in perspective, the entire degree program has slightly more than 40 courses, so that this one student has effectively paid 50% more tuition than he or she should have, if no courses had been repeated. It is difficult to imagine this student being employed as an effective engineer in the near future.



Figure 4: Number of repeated courses by current students.

Similar to Table 3, Table 8 shows which courses have been repeated by this group in the cohort. Most of the classes are the same as with the graduated students group. However, a tally of the number of repeats shows us that these 14 current students have amassed 142 repeats, which is nearly the total from the graduated students in the cohort (153 repeats). Most of the same courses are represented in roughly the same order. The sophomore-level mechanics classes are giving many of our students the most difficulty.

Table 8: Courses repeated by current students

<i>Class</i>	<i>Repeats</i>
ES 204	16
ES 202	13
ES 201, MA 242	12
PS 160	11
MA 243	9
ES 206	7
CEC 220, MA 345	6
AE 301, PS 250	5
AE 304, ES 305, PS 150	4
AE 404 (418), EGR 200, MA 441	3
COM 221, EC 225, ES 320, ES 321, MA 241	2
AE 302, AE 313, AE 413, AE 426, EC 210, EGR 115, EGR 495A, HU 145, PS 253	1
Total	142

Table 9 presents similar information as Table 4, on how many times a particular course was repeated. Although the single repeats are again a majority, there are more doubles, triples, and quadruples than with the graduated students group.

Table 9: Number of times a course was repeated, current students

<i>Repeats for one course</i>	
Single repeat	88
Double repeat	17
Triple repeat	4
Quadruple repeat	2

The details of student success with course retakes are shown in Table 9. It is clear that these are not students choosing to bring a C up to a B, but are retaking a course because they have failed to pass their courses with an acceptable grade.

Table 9: Original grade versus new grade for repeated courses, current students

Original – new grade	Occurrences	Original – new grade	Occurrences	Original – new grade	Occurrences	Original – new grade	Occurrences
F - AU	1	D - AU	1	W - AU	0	AU - AU	0
F - W	2	D - W	1	W - W	1	AU - W	0
F - F	9	D - F	2	W - F	2	AU - F	4
F - D	15	D - D	5	W - D	5	AU - D	7
F - C	22	D - C	11	W - C	5	AU - C	4
F - B	14	D - B	14	W - B	3	AU - B	6
F - A	4	D - A	2	W - A	0	AU - A	1
total	68	total	36	total	17	total	22

Table 10 distills the success of the course retakes, similar to Table 6. Once again, the author will denote a “success” as an improvement of at least two letter grades, with the details the same as in the previous section and with Table 6. By this definition of success, 66 of these re-taken courses are not described as success, while 74 are described a successes (slightly better than one half, compared to the two-thirds with the graduated group).

Table 10: Grade improvement upon retaking courses

<i>Improvement</i>	
Negative one letter grade!	2
No improvement	26
Positive one letter grade	38
Positive two letter grades	45
Positive three letter grades	25
Positive four letter grades	4

Students who left Embry-Riddle

The accumulation of these data presents an opportunity to investigate some academic records of those students who left ERAU. The following tables are very similar to those for the other groups of the cohort. Table 11 shows the number of semesters enrolled at ERAU for the students who eventually left. This study includes no information on why the students left. The number of students from the 174 student cohort who left the university is 63, shown in Table 1. This is 36%, and while this number may seem high, it should again be recognized that ERAU is a niche school and does not have an over-abundance of programs from which an engineering student may choose as alternatives. One might hope that students would quickly recognize when engineering is not for them and find a new direction, but this is not always the case. Upon viewing Table 11, it appears there are some students who take too many semesters to leave. Of course, there certainly may be some students who have left for reasons other than not being successful in AE or ME, and some of the following evidence leads to that possibility, although this is likely not the case for a majority of these 63 students.

Table 11: Semesters at ERAU before leaving ERAU

Regular semesters	<i>Summer semesters</i>		
	0	1	2
1	3	0	0
2	26	0	0
3	11	0	0
4	12	2	0
5	1	1	1
6	0	0	2
7	0	1	1
9	0	0	2

Figure 5 presents the cumulative GPA for these students. Only seven (7) of these students had a GPA above a 3.0, which indicates that a majority were not highly successful upon leaving.

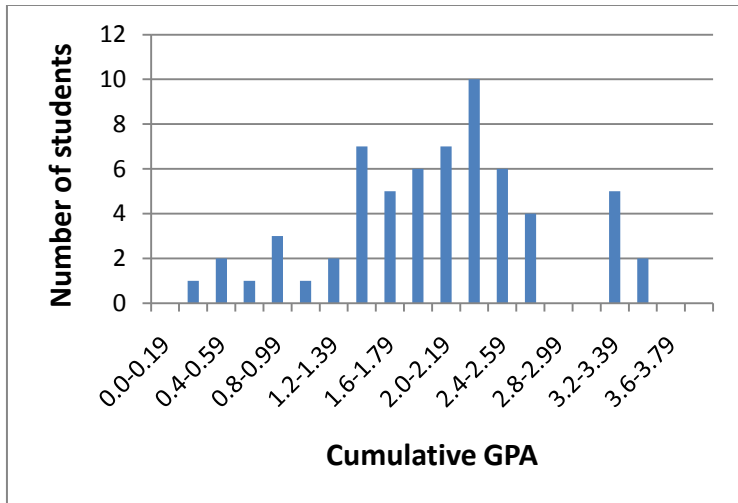

Figure 5: Cumulative GPA for students who left ERAU.

Figure 6 shows the number of repeated courses for the group of students who left ERAU. While the number of students not repeating any course is quite high, it should be noted that many students left with poor grades during their final semester, and therefore did not repeat these courses at ERAU.

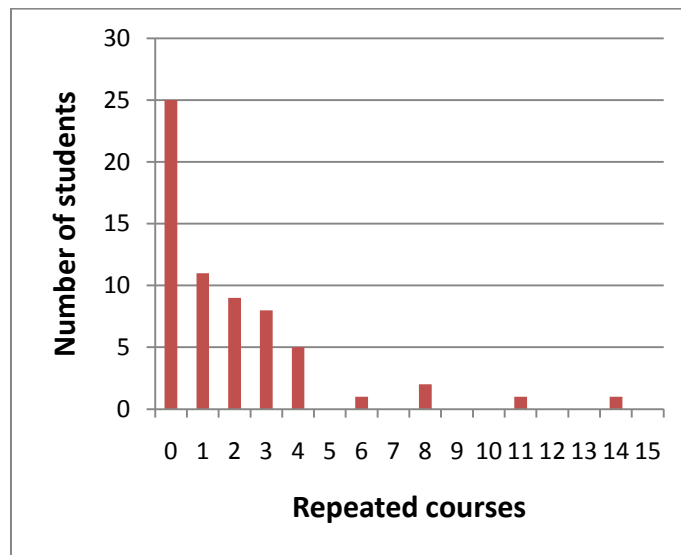

Figure 6: Number of repeated courses for students who left ERAU.

Table 12 is instructive to those seeking to understand which courses freshmen struggle with most. Physics 1 (PS 150), Calculus 1 and 2 (MA 241 and MA 242) lead the pack, and some of the others are familiar from Tables 3 and 8. EGR 115 is the freshman/sophomore introduction to programming course, and CEC 220 is the freshman Digital Circuits course. COM and HU are communications and humanities courses. The total number of repeats, 120, is nearly two repeats for every student.

Table 12: Courses repeated by students who left ERAU

<i>Class</i>	<i>Repeats</i>
PS 150	16
MA 241	14
MA 242	13
EGR 115	10
CEC 220, PS 160	9
ES 201	8
MA 243	6
MA 345	5
EGR 200, COM 122	4
MA 145, PSY 101	3
CEC 222, ES 305, HU 145, PS 103	2
AE 313, COM 219, EGR 101, EGR 210, ES 202, ES 204, PS 105, PS 250	1
Total	120

Table 13 gives the number of times a course was repeated. However, this cannot be assumed to be the number of repeats required for a successful result. Many of these courses were never successfully passed, since many poor grades occurred during the final semester(s) at ERAU.

Table 13: Number of times a course was repeated for students who left ERAU

<i>Repeats for one course</i>	
Single repeat	80
Double repeat	9
Triple repeat	6
Quadruple repeat	1

Similar to earlier sections of this paper, Table 14 provides details of each attempt, and Table 15 documents the improvement upon each repeat. Again, according to the author's definition of success, the results are instructive. A total of 83 of the retakes result in a improvement of one letter grade or lower, and 34 repeats are "successful" in an improvement of at least two letter grades (only 29% were "successful"). Three retakes which included course transfers were not included in Table 15. It is clear that unsuccessful retakes of courses may be a useful indicator of a student at risk for leaving ERAU.

Table 14: Original grade versus new grade for repeated courses, students who left ERAU

Original – new grade	Occurrences	Original – new grade	Occurrences	Original – new grade	Occurrences	Original – new grade	Occurrences
F - AU	2	D - AU	1	W - AU	0	AU - AU	0
F - W	4	D - W	2	W - W	7	AU - W	1
F - F	22	D - F	3	W - F	11	AU - F	5
F - D	10	D - D	3	W - D	2	AU - D	2
F - C	14	D - C	7	W - C	1	AU - C	1
F - B	4	D - B	7	W - B	0	AU - B	1
F - A	1	D - A	4	W - A	1	AU - A	0
total	54	total	28	total	22	total	10

Table 15: Grade improvement upon retaking courses, students who left ERAU

<i>Improvement</i>	
Negative one letter grade!	4
No improvement	58
Positive one letter grade	21
Positive two letter grades	23
Positive three letter grades	9
Positive four letter grades	2

Students who switched majors at Embry-Riddle

The last group of students from this cohort is the group who remained at ERAU but switched majors, totaling 23 (five of these were still enrolled at ERAU as of August 2012). While the author decided against providing the same statistics for course repeats, one useful piece of information is the number of semesters the student persisted at ERAU before switching majors, shown in Table 16. The reader is advised that the data in Table 16 are approximates, since occasionally it appears that a student may have informally switched majors, enrolling in classes towards that new major, without formally declaring the major to the Records department. The author tried his best to estimate when the student was actively taking a majority of courses towards the new major, and no longer taking courses towards an AE/ME degree.

Table 16: Semesters before switching majors at ERAU

<i>Semesters before switching major</i>	<i>Number of students</i>
1	7
2	7
3	2
4	0
5	1
6	1

Most students appear to switch majors within the first two semesters, which is likely a positive outcome, rather than persisting in engineering for too many semesters.

Summary

Numerous tables and plots are presented in this paper. A detailed picture of the performance and some of the academic habits of our students is emerging. The sum of these data shows interesting behaviors of our students, and can aid in making adjustments to degree graduation requirements. For instance, the AE/ME department was considering limiting the number of times a student might retake any class, including Withdrawns and Audits, to two retakes. The thought was this might light a fire, so to speak, under students and get them to put more effort into passing a class the first time. However, in light of this work, this may be a less important solution, and it may be more important to limit the total number of retakes. It is apparent that a significant percentage of students retaking classes fail to achieve significant improvement, showing a lack of ability to develop a mastery of the course material.

Some academic trends are similar to those at other universities. Around half of the students persist in the engineering major to graduation. Freshman and sophomore course, such as calculus, physics, and second year mechanics courses appear to give student the most difficulty. Around a third of these engineering students left Embry-Riddle, a figure which attracts the notice of academic administration and leads to retention efforts.

The author hopes to bolster this work in the future by adding additional students to the cohort for a more robust representation of our engineering students.

Bibliography

1. Helbling, J., Lanning, D., Madler, R., Marriott, D., and Siebold, K. (2007). "Impact of New Facilities on Engineering Student Outcomes," Proceedings of the ASEE Annual Conference and Exposition, June 24-27, Honolulu, Hawaii.
2. Embry-Riddle Aeronautical University Undergraduate/Graduate Catalog, Prescott campus, 2012-2013. Available at www.erau.edu.

Work In Progress: Teaching Introductory Digital Design Online

Bridget Benson, Bryan Mealy
Electrical Engineering Department
California Polytechnic State University San Luis Obispo

Abstract

Advances in technology have created unique opportunities for teaching digital design courses. Students in the course no longer need to be present in the laboratory in order to obtain practical hands on experience and master the course material as students can complete laboratory assignments at home using relatively inexpensive commercial off the shelf development platforms and free software design tools. In addition, eLearning tools such as Moodle, YouTube, chat rooms, and forums make providing and submitting course materials, questions, and obtaining feedback efficient and simple. This paper describes a work-in-progress to port a laboratory intensive introductory digital design course, currently taught in a flipped classroom format, into a 100% asynchronous online course. The paper provides an overview of the current flipped classroom format and then describes our approach to converting this course to an online format. A fully online laboratory course creates new opportunities for students around the globe to obtain access to hands-on engineering education.

Introduction

Online education has become prevalent and even popular in many fields due to its flexible, somewhat self-paced nature and relatively easy accessibility (you can take an online course from anywhere with an internet connection). However, online courses have not become prevalent in many engineering disciplines because these courses typically require use of expensive laboratory equipment and support software in order to complete course assignments. Yet, advances in technology have created unique opportunities for teaching laboratory based digital design courses online because students can now complete laboratory assignments in any setting using relatively inexpensive commercial off the shelf development platforms and free software design tools.

This paper describes a work-in-progress to port a laboratory intensive introductory digital design course, currently taught in a flipped classroom format, into a 100% online course. This paper briefly describes the ongoing evolution of digital course offerings including up to the current course curriculum in its flipped classroom format. We then outline the current efforts to change the flipped classroom format into an online format and then discuss how we plan to assess the efficacy of the online course. The first offering of this online format is scheduled for Summer 2013.

A literature search reveals that few online introductory digital design courses have been documented. Those that have been documented are either primarily self-paced modules that act as supplemental material for face-to-face courses¹ or are fully online courses that lack a laboratory component that makes use of digital hardware^{2,3}. A kickstarter project was recently

proposed describing efforts to create an open source hardware based digital design course⁴ but has yet to be developed.

History and Overview

The notion of porting a digital design course currently taught in a flipped classroom format to an online format follows an ongoing evolution in the mode of instruction for digital design courses at the authors' institution. The first major change in digital course formats was switching from a standard lecture-lab format (where lecture and lab are taught as separate classes potentially by different instructors) to a studio format (where lecture and lab are taught together in the same class with one instructor). Offering a digital design course in a studio format provides better support for meeting learning objectives in the course by enhancing the active lab portion of the course while reducing the notion of passively listening to lecture⁵. The addition of the flipped classroom approach continued to build upon the successes of the studio format by further reducing the passive component of the course.

The push to provide online course offerings represents the latest step in modifying the format of digital course offerings. While the efficacy of online courses is well-known, the online format has caught the attention of academic administrators in their effort to offer quality instruction to a wider audience in an era of shrinking budgets. The notion of online engineering education definitely raises questions of course quality, but initial research indicates that online education can reach its learning objectives as well as or even better than the face-to-face course².

Current Flipped Classroom Format

We teach our current digital design course, CPE 133, in a flipped classroom format. In a flipped classroom, students watch video lectures on their own time and spend classroom time solving various 'homework' problems. CPE 133 meets in two three-hour blocks each week. Each class meeting starts with a 15 minute quiz that covers the material presented in the previous class and is followed by a 15 minute review of the quiz and associated material. Students then work in groups of 2-3 for the next 50 minutes working on solving problems on paper associated with the lecture video assigned to be viewed prior to class time. These video lectures were created by the author using a **Wacom Bamboo Tablet** and **Camtasia** screen capture software. Students spend the remainder of the class period working on various laboratory assignments.

All laboratory assignments make use of the **Digilent Nexys II** development board and **Xilinx ISE**. The development boards are relatively inexpensive and allow students to easily implement their assignments without spending time wiring circuits. The Xilinx software is available for free download and allows students to model (VHDL), synthesize, and simulate their design assignments. We use a **Moodle** site to provide all course materials (i.e. course textbook⁶, in-class problems, video lectures, lab assignments, references, etc.) and to allow students to submit their work in electronic format. Students also take one in-class midterm, one final exam, and complete one final design project.

The flipped classroom format for this course is popular among students as they are able to stop, rewind, and rewatch video lectures as needed, get plenty of practice solving problems on paper

in class (which helps them prepare for the midterm and final), and get plenty of time working with real digital design hardware. They also have access to the Professor in class and in office hours to ask questions regarding the videos, in-class problems, and laboratory assignments.

The online course would essentially be the same course as the flipped classroom course, but would require that all interaction be conducted virtually.

Porting to a Fully Online Course

Porting the flipped classroom CPE 133 course to a fully online course requires replacing all face-to-face interaction with virtual interaction. To maintain the course's efficacy, the learning objectives, problem assignments, quizzes, laboratory assignments, final design project, and final exam all retain the same content as in-class instruction. Table 1 outlines how online tools will substitute for typical face-to-face interactions associated with in-class instruction.

Table 1: Face to Face to Online Conversion

Face to Face	Online Tool
In-Person Q&A on Video Lectures	Moodle Forum (Q&A)
In-Person Debug Support	Moodle Forum (Debug)
In-Class Quizzes	Moodle Quiz
In-Person Office Hours	Skype or Moodle Chat
In-Person Lab Demonstrations	YouTube (or similar)
In-Class Final Exam	Moodle Quiz
Classroom Participation Monitoring	Log Files (tracking video viewership, number of forum posts, last sign on dates, etc.)

Porting the flipped classroom CPE 133 course to a fully online course also requires that students set up their own digital design environment. Table 2 shows the hardware and software tools required for the online course. The only potential additional cost to the student (over the face-to-face flipped classroom format) is a video recording device as the online course requires that students use some type of video recording device to demonstrate their working laboratory assignments. However, many students already have devices with video recording capabilities (i.e. smart phones, web cameras, etc.).

Table 2: Hardware and Software requirements for the online course

	Item	Cost
Hardware	Digilent Nexys II board	\$100
	Web Camera	\$0-\$25
Software	Xilinx ISE	\$0
	Video Recording Software	\$0

The online course will use a similar schedule of topics as the face-to-face flipped classroom course. The primary differences between the two formats is that students can choose when to watch the lecture videos, when to complete the quizzes, and when to complete the laboratory

assignments, so long as they complete each quiz or assignment by the specified deadline. Table 3 shows the proposed course schedule for the online course.

Submission of quizzes will be due every Tuesday and Thursday evening at 11:59pm, with each quiz covering the scheduled topics. Submission of lab assignments, including both a video demo of the working hardware and a laboratory report write-up, will be due every Sunday evening at 11:59pm. As previously mentioned, the online course will use the same lab assignments as the face-to-face course. The seemingly large number of these lab assignments is mitigated by the fact that most of the assignments reuse digital modules designed in previous experiments. Moreover, the assignments are designed to ensure that they can be 100% verified using a video recording device.

Table 3: Proposed Online Course Schedule

Week	Tuesday	Thursday	Sunday
1	Number Systems	Logic Gates, Circuit Forms	Lab 0
2	K-maps	Functionally Equivalent Gates	Labs 3, 4
3	Structural Modeling	Behavioral Modeling	Labs 5, 6
4	Decoders	Multiplexors	Labs 7-9
5	Modular Design Problems	Static Logic Hazards	Labs 10, 12
6	Parity Checkers	Signed Numbers	Labs 13, 14
7	Sequential Circuits	Flip Flops	Labs 18, 19
8	FSM Intro	Sequence Detection	Labs 20, 21
9	FSM Timing	FSM Multiplication	Lab 26
10	None (Project Time)	None (Project Time)	Final Exam (6-9pm)

Changing the course format from the flipped classroom format to the proposed online format may give rise to some concerns. Table 4 on the following page lists some concerns one may have with the online course and addresses how these concerns can be viewed as a pro or con for online instruction. The authors feel that because many of the concerns may actually provide an added benefit to the course and other concerns can be adequately addressed through appropriate online tools, the online course has great potential to be an excellent alternative to its face-to-face counterpart.

Proposed Assessment

The current curriculum provides a unique opportunity for assessing the online course. Most students taking CPE 133 take CPE 233 the following quarter. CPE 233 is a course in computer design and assembly language programming that requires students to apply the design and modeling skills they learned in CPE 133. Students who took the online CPE 133 will be mixed with students who took the face-to-face version of the course. Because CPE 233 is currently taught in only a face-to-face format, we plan on assessing our students in two ways to address lingering concerns with the online format.

First, we will give CPE 233 students an exam on the first day of class that covers topics they should know from CPE 133. Additionally, we will give a similar assessment exam at the end of CPE 233 to see if students from either the face-to-face or online course perform better overall in the second quarter of digital design.

Secondly, we will track and record student performance on laboratory assignments to determine whether students working at home are at a disadvantage or advantage to students working in the in-classroom laboratory in terms of hands-on laboratory skills. We anticipate that students working at home may have better troubleshooting skills than students working in the in-classroom laboratory who rely on the instructor for spotting bugs in their VHDL code.

Table 4: Potential concerns with the online course.

Concern	Online Con	Online Pro
Students must work individually	Students lose the face-to-face team experience with a lab partner. However, students will still be encouraged to work together through posting and responding to forum posts.	All students will be solely responsible for completing all assignments. They will not be able to just sit in the shadows of a lab partner.
Students have to set up their own laboratory environment	Professors may spend significant amounts of time troubleshooting problems that arise with downloading and installing the course software in the first week of class.	Students will learn the basic requirements of setting up a laboratory environment (purchasing hardware and downloading and installing software). Students will have the tools they need to do digital designs beyond what the course requires.
Students need to own appropriate equipment to create videos of their lab demos	Increased cost on the student if he or she does not already own a web camera or similar video recording device.	Students will gain practice orally presenting their work in a clear and concise manner. Students can also exercise creativity in creating their videos.
Students cannot ask questions in real-time	Students do not have immediate access to the Professor or their colleagues to help solve various problems that may arise.	Students can post all questions to an online forum and respond to other student's posts. Students can also engage in synchronous discussion with the Professor through online office hours.

Conclusion

Advances in technology have created unique opportunities for teaching laboratory based digital design courses online because students can now complete laboratory assignments in any setting using relatively inexpensive commercial off the shelf development platforms and free software design tools. Because students can now cover the same course content and conduct the same hands-on laboratory assignments in an online course as they could in a face-to-face course, concerns about course efficacy are mitigated. Additionally, our approach to an online introductory digital design course has many potential advantages over its face-to-face counterpart including encouraging students to 1. work independently, 2. develop troubleshooting skills, and 3. practice verbal skills to succinctly describe their design work.

Our approach to this online course also has advantages that extend beyond our current course offerings. Because this is a pilot offering of the online version of this course, we expect to gather much useful knowledge and experience. We intend to use this information in our expected design of other digital design courses. Additionally, we feel strongly that knowledge and skills, particularly in the field of engineering, should be readily assessable to any student. Online courses provide the means to overcome social and economic barriers around the globe by creating new opportunities for students to obtain access to hands-on engineering education.

Bibliography

1. Self Paced Digital Logic Computer Assisted Learning Module. University of Surrey.
<http://www.ee.surrey.ac.uk/Projects/Labview/intro.html>
2. Brock LaMeres. "A Comparison of Student Learning in an Introductory Logic Circuits Course: Traditional Face-to-Face vs. Fully Online." Montana State University College of Engineering. May 2011.
http://eu.montana.edu/online/faculty/teach/pdf/Live_vs_Online_Study_EE%20261_May2011.pdf
3. Introduction to Digital Logic and Hardware Architecture. UC Irvine Extension.
<http://unex.uci.edu/courses/sectiondetail.aspx?year=2013&term=Winter&sid=00100>
4. Kickstarter Project. Open Education: An Introduction to Digital Electronics.
<http://www.kickstarter.com/projects/pyroelectro/open-education-an-introduction-to-digital-electron>
5. Bryan Mealy and Brenton Parks. "Work in Progress – PLD-Based Introductory Digital Design in a Studio Setting." ASEE/IEEE Frontiers in Education Conferences. October 2007.
6. Bryan Mealy. Digital McLogic Design. www.freerangefactory.org

Academic and Research Cooperation between University of Washington Tacoma and Brazilian Universities

Fabrício Braga Soares de Carvalho
Federal University of Paraíba – Brazil

Orlando Rocha Baiocchi
Institute of Technology - University of Washington Tacoma

Robert Friedman
Institute of Technology - University of Washington Tacoma

Abstract

Partnerships with foreign engineering schools and universities are important to paving the way for global research and cooperation efforts with American institutions. The objective of this paper is to present how the University of Washington Tacoma (UWT) is working closely with Brazilian universities to receive undergraduate students under the Brazilian Science Without Borders program, as well as to enhance academic, cultural and research achievements through international cooperation.

The presence of Brazilian students helps improve student outcomes at UWT by aggregating the local students with the foreign ones in coursework that derives from fundamental and applied research being conducted by partnering institutions. These partnerships promote the development of UWT faculty and programs, and enhance the reputation and visibility of both the Institute of Technology and UW Tacoma, while also providing a global bridge for computer engineering studies.

University of Washington Tacoma

The Institute of Technology¹ at the University of Washington², Tacoma, provides focus for the rapid development of high-technology academic programs that serve the needs of the state of Washington.

Launched in 2001, the Institute has supported the South Puget Sound community by building facilities, classrooms and labs to support STEM education. Through innovative partnerships with area companies, internships and funded research projects, Institute students gain real world experience to tackle the challenges of a continually evolving industry.

Degrees offered by the Institute of Technology are:

- Computer Science and Systems (BS/BA/MS)
- Computer Engineering and Systems (BS)
- Information Technology and Systems (BS)
- Professional Master of Cyber Security and Leadership

The Institute of Technology at the University of Washington Tacoma was created to provide the highest quality computing, engineering, science, and technology education for a diverse population and to engage in research and innovation that benefits the community by fostering social mobility and economic development. There are 11 tenure track faculty, 5 full-time lecturers, 11 part time instructional faculty, and 9 administrative and lab staff who are dedicated to the educational success of nearly 440 matriculated and non-matriculated students in its programs. Over 600 students have completed Institute programs and have been awarded University of Washington undergraduate and graduate degrees.

The vision of the Institute derives from its unique public-private partnership in higher education, one charged with serving as a catalyst for generating energy and interest in computing & engineering disciplines. Its goals include developing and enhancing faculty teaching and research while increasing students' communication and collaboration skills; expanding and diversifying student enrollment; continuously developing, assessing and improving its program offerings; and extending its reach and support within the community.

The Institute offers students unique R&D opportunities and hands-on preparation for computing-related careers in information-centric industries that are fundamental to the future of the state of Washington. In addition to its core undergraduate and graduate programs, the Institute has developed new applied computing partnerships with other academic units on the UW Tacoma campus, such as Healthcare Leadership, Criminal Justice, and Geographic Information Systems. With research strength in Big Data, Information Assurance, CyberSecurity, and Wireless Sensor Networks, the Institute of Technology's faculty brings their expertise both into the classroom and the community.

Science Without Borders Program

The Science Without Borders program (in Portuguese: *Ciência Sem Fronteiras*) is a major effort from Brazilian government to foster science and technology in the country. Although science in Brazil has demonstrated a significant growth in recent years, the country still faces major challenges³:

- to increase the number of PhD's relative to the general population;
- to enhance interaction between academia and both the business sector and civil society;
- to promote international collaborations in scientific publications;
- to boost the rate of patent applications nationally and internationally.

The main goal of the program, according to Brazilian government is³: “to promote the consolidation and expansion of science, technology and innovation in Brazil by means of international exchange and mobility. The strategy envisioned aims to (a) increase the presence of students, scientists and industry personnel from Brazil in international institutions of excellence, negotiate the existence of support from the private sector for the payment of the fees involved or the exemption of these fees with universities or local governments, (b) encourage young talent and highly qualified researchers from abroad to work with local investigators on joint projects, contributing to the capacitation of human resources and promoting the return of Brazilian scientists working overseas, and (c) enhance the internationalization of universities and research

centers in Brazil by encouraging the establishment of international partnerships and a meaningful review of their internal procedures in order to make interaction with foreign partners feasible.”

By the end of 2012 Brazil had sent approximately 20,000 students from all levels (undergraduate; graduate; PhD candidate and post-doc professional) to 39 different countries, as well as attracted more than 500 international scientists to develop research and cooperation in Brazilian institutions³. According to the Brazilian government these numbers will increase over the next few years.

Cooperation between UWT and Brazilian Universities

The University of Washington Tacoma is recognized for attracting international students from several countries. UWT also believes that, given the increasing globalization of computing and engineering, multiethnic and multicultural classes help to better prepare future engineering professionals for current and future market demands.

In this context, the Institute of Technology is expanding its international cooperation by hosting Brazilian undergraduate students in the Computer Engineering and Systems program for the 2012-2013 academic year. It is the first collaborative, multi-disciplinary, sustainable research effort in the Computer Engineering and Systems program at the Institute of Technology, University of Washington Tacoma.

These students were recruited through established, strong faculty connections and Memoranda of Understanding for long-term collaboration between UW Tacoma and the Institute for Advanced Studies in Communications (IECOM)⁴, the Federal University of Campina Grande (UFCG)⁵, and the Departments of Electrical and Computer Engineering at both the Federal University of the Vale do São Francisco (UNIVASF)⁶ and the Federal University of the Recôncavo da Bahia (UFRB)⁷.

Currently UWT has signed cooperation agreements with more Brazilian institutions, in order to receive undergraduate students and to boost the cooperation with the Federal University of Paraíba (UFPB)⁸, Federal University of Pernambuco (UFPE)⁹ and Presbyterian Mackenzie University¹⁰.

Objectives and Achievements of the Cooperation

In building the current cohort of Brazilian students, several objectives were considered.

First of all, to include students from as many Brazilian universities we have agreements of cooperation with as possible. In this scenario, UWT has signed cooperation terms for long-term collaboration with some important institutions from Brazil: IECOM and UFCG, UNIVASF, UFRB.

Today, more universities are already working with UWT and some of its existing industry partners such as Intel and Boeing, on academic and research topics. Moreover, Brazilian institutions are currently signing specific Memoranda of Understanding to formalize on-going

partnerships with UWT and the Institute of Technology, including UFPB, UFPE, Presbyterian Mackenzie University.

One important point of cooperation planning consisted in choosing students who share common interests with UWT faculty areas of expertise. In this specific case the area of interest is “Wireless Communications” due to the depth of experience and achievement of the Computer Engineering staff from the Institute of Technology in this important topic.

After selecting the first Brazilian students for the 2012-13 academic year, the next step was to create a research group that included both Brazilian and US students and faculty. This is an important contribution for the Institute of Technology as well as for Brazilian students and their research teams in Brazil: when coming back to Brazil after the academic year, these students will be able to continue the ongoing research with the group in UWT and to improve the level of research in their original schools in Brazil. This will also strengthen the cooperation between Brazilian institutions and the Institute of Technology.

In this context the research group is concentrated on a topic of applied research that serves both Brazil and Washington interests: Wireless Sensor Networks (WSN). Wireless Sensor Networks are an important technology in the 21st century; due to advances in wireless communications and computational processing, the concept of ubiquitous computing is everywhere.

WSN is a topic of current interest in the state of Washington, across the country, and around the world, as recently stated¹¹. In 2003, the National Science Foundation had already indicated WSN as one of the most important research areas in networks¹². It opens a unique opportunity for collaboration between the Institute and both the Environmental Science program and the UWT Center for Urban Waters, as well as with other University of Washington research centers and state/federal agencies interested in remote sensors and their applications.

A relevant achievement of the conjoint research is the possibility to apply for external funding both in Brazil and the US. There is great potential for external funding from agencies such as the Departments of Agriculture, Energy, Defense, Homeland Security, as well as by the National Science Foundation, PNNL, NIST, NOA and Nature Conservancy. In Brazil, CAPES¹³ and CNPq¹⁴ are the main public agencies supporting finance and logistical needs to help expand the level of scientific research in the country.

Preliminary results of the cooperation allow the expansion of the research scope to include advanced centers in wireless communications field. Cooperation has been established with the Northwest Laboratory for Electromagnetics and Acoustic Research (NEAR)¹⁵ at Portland State University, a leading research institution in the remote sensors area, to establish a joint research program with the Institute of Technology. The emphasis is on environment-related problems.

The Institute of Technology of the UWT is focused on balancing students’ activities during this academic year. It’s very important to mix research activities with classes in other courses of Computer Engineering, but also to enhance language skills and cultural exposure. Such activities help foreign students rapidly adapt to the new school and country and to deal better with local particularities. Also, it helps to make these and UWT students true world citizens.

Conclusion and Future Developments

Despite the fact that our involvement with the Science without Borders program started just a few months ago, significant progress has been made. The current students have successfully completed their first quarter with excellent grades in their respective courses. The research activity in the Wireless Sensors Network group has gathered considerable momentum already and almost twenty people are now involved, including the Brazilian students, UWT undergraduate and graduate students, Institute faculty, and more recently, members of the industry.

What differentiates our approach from most other institutions is that we are building a sustainable research program in a specific area that has many different applications and is of great interest to all institutions involved. The first concrete results have been produced: a prototype of a wireless sensor to measure room occupancy has been built and preliminarily tested. We intend to develop this project to include simulations of the electromagnetic environment and correlation with energy consumption, as well as other applications like monitoring of humidity and temperature in an agricultural environment. Moving from electromagnetic to the acoustic sensing, the development of systems capable of locating fish populations and underwater oil patches will be explored. As we progress in this work and increase our cooperation with Brazilian institutions, we will establish more tangible objectives and develop metrics to measure the outcomes of this project.

Bibliography

1. <http://www.tacoma.uw.edu>
2. <http://www.tacoma.uw.edu/institute-technology>
3. <http://www.cienciasemfronteiras.gov.br/web/csf-eng/>
4. <http://www.iecom.org.br>
5. <http://www.ufcg.edu.br>
6. <http://www.univasf.edu.br>
7. <http://www.ufrb.edu.br>
8. <http://www.ufpb.br>
9. <http://www.ufpe.br>
10. <http://www.mackenzie.br>
11. S. SUDEVALAYAM and P. KULKARNI. *Energy Harvesting Sensor Nodes: Survey and Implications*. IEEE Communications Surveys & Tutorials, Vol.13(3), pp. 443-461. 2011.
12. Report of the National Science Foundation Workshop on Fundamental Research in Networking. April 24–25, 2003. Available at <http://www.cs.virginia.edu/~jorg/workshop1>
13. <http://www.capes.gov.br>
14. <http://www.cnpq.br>
15. <http://nearlab.ece.pdx.edu>

Compact International Experiences: Two-year Reflections on Short-term Study-abroad Elective Engineering Courses

**Frank G. Jacobitz, Thomas F. Schubert
Department of Engineering, University of San Diego**

Abstract

In response to an effort by the home institution to internationalize the curriculum as well as strong student desire for engineering international studies, compact international experience (CIE) courses were developed. The efficacy of delivering such engineering electives as study-abroad, short-term courses is described through the experiences gained by repeat offerings in January 2013 of two distinct three-semester-unit courses in a three-week time frame in France and Australia. While each of these courses, Topics in Fluid Mechanics and Advanced Electronic Circuit Design, focused on its technical content, the desire for student understanding of the cultural environment and the impact of engineering solutions from a global and societal viewpoint were strong driving factors for each. The development of the two courses was undertaken with the hypothesis that CIE courses can successfully be taught in an intersession format while providing an international experience to the students. In the second offering of each course, increased interaction with local industry was a goal. Assessment of the program was carried out through typical course evaluations, student surveys, student reflection papers, and formalized instructor observations. Overall, these CIE courses have been found to be a valuable approach in the delivery of senior-level technical electives combined with an international experience.

Introduction

Over the past decade, the number of students at the University of San Diego (USD) involved in an international experience has surged to the point where more than 85 percent of USD's undergraduates participate in study-abroad programs.¹ There are a variety of reasons for this increase including an effort by the institution to internationalize the curriculum and a desire of students to incorporate global competencies in their studies. An international experience can be obtained in many different ways, including year-long or term-based study-abroad programs, summer or intersession study-abroad classes, or courses with an international focus taught at the home institution.²

Despite a desire by engineering student to participate in international experiences, engineering students are typically underrepresented in study abroad programs. Two faculty in the engineering program at USD have developed senior elective courses in mechanical engineering and electrical engineering to be taught abroad. These courses, *Topics in Fluid Mechanics* and *Advanced Electronic Circuit Design*, were first offered in January 2010 in France and January 2011 in Australia, respectively.^{3,4} Due to the success of these courses, repeat offerings of the two classes occurred in January 2013.

As part of the development of the two courses, the concept of Compact International Experience (CIE) course was developed. CIE courses are short-term, faculty-led, study-abroad courses with the goal to combine technical engineering content with an international experience. The course technical content is delivered through daily lectures within a three-week time period. Additional lectures or presentations cover cultural or global engineering topics. The international experience is rounded off by excursions in the host country to further the cultural or international engineering experience. These courses were designed with the hypothesis that CIE courses can successfully deliver technical content equivalent to courses delivered at the home institution while providing an enriching international experience.

The technical content and the international experience are assessed using a three-pronged approach. (1) Instructor observations and course grades are used to assess the efficacy of the delivery of technical material. These observations are compared to similar courses taught in a semester-long format at the home institution. (2) Students write weekly reflection papers concerning their total experiences. Finally, (3) a survey instrument is used to assess the international experience of the students.

In the following, each of the two engineering courses is described. Next, the assessment methods are described and assessment results are presented and discussed. Finally, conclusions are drawn from the assessment results.

Description of the two Compact International Experience Courses

The electrical engineering senior elective course, Advanced Electronic Circuit Design (ELEC 403), was offered during January 3 to 22, 2013 dividing time between Sydney and Canberra, Australia (figure 1). The course explored contemporary electronic design beyond that usually taught in the two electrical engineering core electronics courses and focused on the analysis and design of analog and digital electronic circuits and systems including: oscillators, non-linear waveform generation and waveshaping, power electronics, communication circuits, and digital gates. There was a strong emphasis on computer-aided analysis and design.

The textbook used was an out-of-print electronics textbook coauthored by the course instructor. Since the authors now own the copyright to the textbook and it is undergoing revision for a new edition, both hard and electronic copies were made available at no cost to the students for their private use. Each student was provided with a licensed copy of National Instruments Multisim™ 12.0 for use as a circuit simulator – arrangements were made so that the department's license could be extended to the student laptops for this course.

The course met for nineteen days with thirty-five scheduled classroom hours and an additional two-hour final exam period. The lectures were conducted in a conference room at the varied locations. The students stayed, typically in rooms of two, in hotels near the main part of each city. The instructor stayed with the students in the same residences in a private room and held office hours either in that room or in a public room at the hotel. Public transportation and private coaches provided easy access to the varied locations.



Figure 1. Advanced Electronic Circuit Design in Australia

Tours and excursions included locations that were intended to be cultural (Blue Mountains Eco Tour, Sydney Opera House, etc.) and some intended to be technical (Canberra Deep Space Communication Complex, Power House Museum, Dolby Labs, etc.) This assortment was intentional and, as such, emphasized that this international experience was more than just a USD engineering course taught in another country. In addition, the students toured the engineering departments at three Australian universities (University of Technology, Sydney; University of New South Wales; and the Australian National University) where they were introduced to engineering research activities at the universities and explored opportunities for international graduate study.

Topics in Fluid Mechanics (MENG 462) was offered in Marseille, France during January 3 to 24, 2013 (figure 2). The course is a senior-level technical elective and the course further developed selected topics in fluid mechanics, including boundary layers, pipe flow, and an introduction to flow stability and turbulence. It also included an introduction to numerical analysis and the students simulated flow problems using Comsol Multiphysics on laptop computers. Guest lectures from students, researchers, and faculty of the host institution included topics such as vorticity in turbulent flows, an introduction to plasma physics and nuclear fusion, and Fourier analysis and applications in turbulence. The lecture on the Reynolds decomposition in turbulent flow was given to a joint group of students from the home and host institutions. The course has been offered by the instructor twice before; first in a semester-long format at the home institution during the spring 2007 and then again as a CIE course in France during the 2010 intersession.

The course was held in Marseille in the south of France. The students stayed in a university residence with individual bedrooms and bathrooms, as well as shared kitchens and living rooms. The instructor stayed with the students in the same residence. The lectures were typically held at the Aix-Marseille Université campus at Chateaux Gombert outside of the city, but within easy reach by public transportation.



Figure 2. Topics in Fluid Mechanics in France

The course met for three weeks with an average of three lecture hours per day. The lectures were conducted in a seminar room at the university. There was one three-hour midterm focused on theoretical material at the end of the second week and a final computational project presented by the students on the last day of classes. The grading was based on homework (six assignments, 30% of the total grade), the midterm exam (3 hours, 4 problems, 30% of the total grade), the final project (3 different computational assignments in groups of 4 or 5 students, 30% of the total grade), and an international component (3 reflections papers, 10% of the total grade).

Group activities had technical and cultural components. A trip to the International Thermonuclear Experimental Reactor (ITER) in Cadarache was mainly technical in nature and it was accompanied by lectures on plasma physics and nuclear fusion by researchers at the host institution. A weekend trip to Paris included a visit to the Musée des Arts et Métiers, which displays many scientific instruments and inventions.

Cultural activities included visiting a variety of local attractions (Chateaux d'If, Vieux Port, Vieille Charite, Calanques), day trips to Aix-en-Provence and Lyon, and an overnight weekend trip to Paris. The students also used afternoons and evenings for a further exploration of the city and its surroundings. French language lessons to facilitate greater cultural immersion for the USD students were conducted by faculty, researchers, and students of Aix-Marseille Université

Instructor Observations and Course Grades

In ELEC 403, there were two midterms and a final exam on the last day of classes. As for a typical course at USD, grading was based primarily on homework, the midterms, and the final exam. However an additional component relating to the international experience was factored into the final grade for this CIE course.

Given the close living accommodations for the students and the course instructor and the tight schedule, homework submission was done on an individual basis. In the course of “office hours” students showed their work and computer simulations to the instructor who often made suggestions as to how to improve each: students made appropriate changes before homework grades were recorded. As a result, all the students achieved homework scores greater than 93%: typical homework grade averages for this course instructor during a normal semester lie in the 75-90% range.

Given that Advanced Electronic Circuit Design has only been offered in a compact format (either abroad or on campus as a summer course), technical comparisons are a bit difficult. However, since the course instructor also taught these students in the prerequisite courses, direct comparisons can be made. The students enrolled in the course obtained an average grade of B (~3.0) in the prerequisite courses while the total student population averaged a B- (~2.7) in those courses. For the CIE course, the average grade was somewhat higher: A- (~3.5) with no student performing at a lower level than in the prerequisites. As was the case for the other CIE course in this study, it appears that strong student interest, close student-faculty interactions, and the concentrated, single-focus format are the primary factors for improved student performance.

The technical evaluation of the three Topics in Fluid Mechanics (MENG 462) courses was quite similar. For the semester-long course taught at the home institution, the grade distribution consisted of 4 As, 3 Bs, and 1 C with an average GPA of 3.4. For the 2010 CIE course, 3 As and 1 B were given with an average GPA of 3.7. For the 2013 CIE course, 10 As and 3 Bs were given with an average GPA of 3.6. The GPAs are relatively high in all courses and there are two main reasons: first, both courses were senior-level electives and only students with a strong interest in the topic enrolled in the course. Second, due to the small student enrollment in the courses, a high level of student-faculty interaction was accomplished. This argument is particularly applicable to the CIE courses due to the shared living arrangements.

Student Reflection Papers

In that Advanced Electronic Circuit Design was presented in different cities (Sydney, Canberra, and the back to Sydney), it was decided to assign the reflection papers essentially on a city-by-city basis. Near the end of each city stay, students were asked to write “a short (~ one page) reflection paper concerning your stay in that city, the cultural differences that you noted, the engineering-related tours and lectures, and anything else that was of particular interest ...” While the content of the papers was not graded, a sincere student effort was required to achieve full credit (tours, guest lectures, and global impacts accounted for a portion of the course grade). Papers were e-mailed to the instructor as soft copies.

Student commentary covered a wide range of topics including food, scenery, animal life, the excursions, and the course itself. Some of their general comments about the international experience are:

“I figured that Australians speak English, so there wasn’t going to be too big of a difference between the places. I was extremely wrong. After stepping foot off the plane, I realized how different the culture is here. There are so many differences, large or small, that intrigues me

every day. Having never been out of the US, I feel like I was close-minded about the rest of the world. Now that I have been here for a week, I am getting a better feel for other countries, and the rest of the world in general. It makes me wonder how different other countries are.”

“I also want to continue meeting the local sydneyiders to learn more about the cultural differences and life “Down Under” so that I can walk away from this study abroad experience a more informed person of the world.”

“This being my first time out of the country, it has been an extremely eye-opening experience. It is immensely interesting interacting with people from a completely different culture and is a type of reality check to me. I had thought about countries outside of the United States before this class, but I had never really known what exactly to think about them. Being here makes a world of a difference and opens my eyes to the reality of how big the world really is. I think it is imperative that if a person wants to be successful in the world, it is necessary for them to see how others in the world are doing in comparison.”

“I found talking with the local people to be a great part of the trip. It was interesting to hear their perspective of the U.S. Some of the Australians are amazed at the issues that America is dealing with and wonder why we have not progressed beyond 1950 Euro-Christian modes of thinking.”

“Study abroad in Australia has been a life changing experience so far. I have learned so much through experiencing a foreign place. It has allowed me to get out of my comfort zone and learn how to adapt to new situations.”

The tours of technical sights and local engineering firms also expanded their thoughts about engineering as an international occupation:

“This has been the part of the trip that has really brought out the global aspect of engineering and science. Even though during the cold war the “space race” was billed between only the U.S. and USSR it really was a global effort for all of humanity. Without these communication arrays in Canberra and Madrid it would be impossible for the US or USSR to handle alone. Another example of the global engineering idea I saw at the museum in Canberra was a picture of the International Space Station. It had all of the parts separated and labeled by which country produced said part. Even though most were from the US a few countries that were on the chart surprised me like Brazil and Finland.”

“Part of this newly found understanding comes from the different tours and adventures we have been on. The most notable one for me was the Space Center. While I had previously known that electronics was vital in space, this tour allowed me to better understand the real uses for it, and how I may be able to apply it in the future.”

“Working for a company such as Dolby would be very amazing, but to also work for them overseas in another country seems almost like an imaginary dream”

“While visiting Dolby Labs, I learned that there are many Engineering related jobs available in the country, but they are extremely competitive. Dolby Labs hires few recent Bachelor Degree

Graduates, and of those few, most are either the Valedictorians or Magna Cum Laude of their class. This fact made the prospect of applying for abroad jobs a little intimidating, however the great possibility of attaining a working visa for Australia was stressed. It is good to know that if I were to eventually become in a position where I could get a job in the country, I could be easily and quickly sponsored to attain a working Visa.”

The visits to the three universities expanded their thoughts about continuing education:

“Study Abroad has given us the opportunity to visit other colleges and consider going into a graduate school. So far we have visited NSWU and UTS, two amazing schools that are open for international students for both undergraduate and graduate school. Before this trip, I never thought about attending graduate school, let alone taking graduate school in another country.”

“It makes me wonder if I should apply to each of them for graduate school, but at the same time I am reminded of the cost of living here in Sydney.”

“Graduate school in Australia seems like a very fun opportunity.”

“Each university we visited sparked interest in me if going to graduate school outside the US is a viable option.”

“I love the United States, but having the abroad experience has made me hungry to travel more and experience more cultures that the world has to offer. I previously never considered working or studying abroad long term, but this experience has inspired me to research some options for working or going to graduate school outside the United States. Sometimes it is hard to think that the world can be much bigger than the small area that I work and live in, but now I have come to realize how many amazing places and opportunities are available all over the world.”

There were also comments about how the CIE experience made them think about their own lives:

“I think the most important thing this trip has taught me was not about the places we went, but the people I went there with. I had always thought relying on other people for help was a weakness. Now I see I was the one with the weakness, an inability to admit when I need help. On this trip I learned it is ok to come to a professor with questions, or ask a classmate when you are having trouble on a homework problem. I know this is stuff people learned in high school, but it finally clicks for me.”

For Topics in Fluid Mechanics (MENG 462) course, three reflection papers were assigned: the first paper was due approximately half-ways through the course, the second just before returning to the US, and the last a few days into the spring semester at the home institution. The reflection papers were assigned to capture students’ observations and attitudes on a regular basis. The reflection papers were mandatory, but their content was not graded in order to encourage students to write openly about their impressions.

The students covered a variety of topics in their reflection papers, including trip preparations, local activities, reports on class activities, or cultural observations. Overall, the opportunity for a study abroad experience was greatly appreciated: “My time spent in France was an amazing, once in a lifetime experience that I will remember for the rest of my life.” “It has definitely been a once in a lifetime experience.”

The students comment about how the experiences have impacted them: “Going back to the U.S. I am excited to see my friends and share everything that I have been able to see and do with them. I will miss Marseille, however, I am excited to see how it feels to be back in the U.S. after experiencing so many different things that I am not accustomed to. I wonder how my perspective on things will be affected. I hope that I maintain many of the changes I have adapted to as I return. All I know is that I will never forget this trip and experience.” “I realized how little I know about the world. I felt like I have been introduced to very few cultures, languages, and activities of different countries thus far.” “I feel that within the past month I have been able to gain a very accurate experience of France altogether.” “It is extremely humbling to be put in a situation in which you cannot expect the people around you to be like the people you grew up with.” “It has been amazing to get to know everyone on such a personal level, and break the barrier of “hi, how are you, how are classes.””

The students also provided observations on the course and academic environment: “Math the Universal Language: While we have had four different lecturers teaching our material, it is incredible that even with the complex language barrier we can still learn. While math has different ‘dialects’ or notations it follows the same form (at least in the western world I do not know if I would understand Chinese notation).” “In terms of academics, I’ve really enjoyed the method of study on this trip. Since we are all leaving from the same place and taking the same transportation to school, it’s great not to have to worry about rushing to not be late for class. The flexible schedule helps, too, as class endings seem to make more sense when not confined to the 55-minute period structure at USD.” “Classes here are also a new experience. Although I am familiar with going to lecture and then a cafeteria then back to lecture, the familiarity of living in the same place as my teacher is a uncommon blessing that allows me to get to know my professor outside of just class and office hours.” “I really enjoy the University campus. Although it isn’t quite as ornate as our campus, I would hope that they would invest their money into more useful things than planters or palm trees. Like everything else here, the University is condensed.”

The course structure and student-faculty interaction were appreciated: “The final project was probably the most challenging part of the entire class, but I feel like I did learn a lot about the software while simulating boundary layers over a flat plate.” “The few hours of class each day is perfect because it gives us enough time to understand the technical part of the course, but is not overwhelming.” “The evening homework sessions are great because they allow us to recap the often large amount of technical material earlier that day, and then work on questions together. I have never worked in groups or partners on anything at USD other than required group projects, and this new approach has been wonderful for me. I feel that I am supported by both Dr. Jacobitz and the other students quite directly, as our small groups ensure that each individual understands the material being covered.” “I feel as though knowing my professor and classmates has helped

in almost every situation. It keeps me focused on school and I am able to enjoy myself more because I am around familiar faces.”

Some students also reflected on a student getting sick: “I think that one of the worst case scenarios for a traveling abroad experience is when someone would end up in the hospital. When it happened to [a student], it was troubling for all of us but I’m very impressed by the way that [the instructors] and the other students handled the situation. [His] health was put as first priority for everybody and as unfortunate as the incident was, it could not have been put in more responsible hands.”

A student was also mindful about the associated cost: “The financial aspect of the course was the main reason for my hesitation when signing up for the course.”

Survey results

The students in each CIE class were asked to complete a survey concerning international awareness immediately before and after taking the CIE course. The survey consisted of 28 queries: 19 taken from the USD School of Leadership and Education Sciences international experience survey, 3 comparing the CIE courses to USD courses given in the traditional semester-long format and during the three-week intersession on campus, 2 queries concerning the international experience as related to engineering, and 4 queries concerning returning to a foreign country for education, work, or pleasure. The survey used a 6 point scale ranging from “strongly agree” (1) to “strongly disagree” (6) and asked for short statements relating examples from the student’s own experience related to the queries. While preserving the anonymity of the respondents, individual pairs of surveys (before and after) were grouped so that individual changes in responses could be tracked.

Students started the CIE courses with high expectations when comparing them to typical courses at USD with an average score over the three questions of 2.22. Interestingly, the CIE courses exceeded their expectations, gaining almost a full point in scoring to an average of 1.30. A full 50% of the individual responses showed gains in scoring (Figure 3).

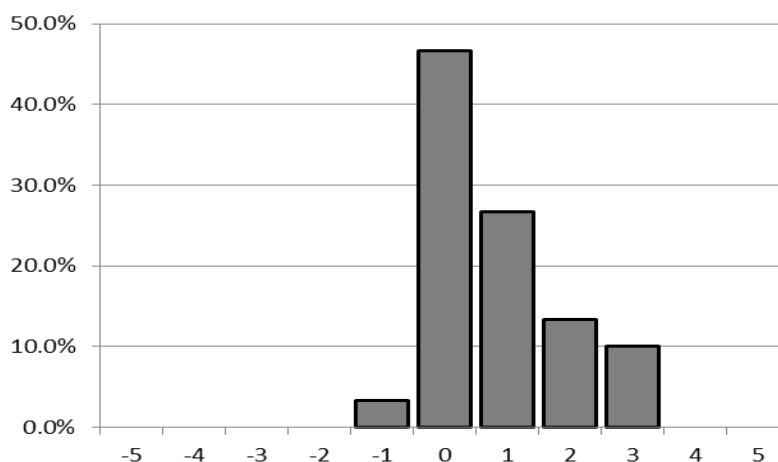

Figure 3. Incremental Change in CIE to Traditional Format Course Comparison

Students started with reasonable international awareness (2.62 average) as described in the 19 international experience queries and showed considerable gains (0.66 average) in their international awareness with 40.6% of the responses showing an increase in awareness as opposed to only 10.8% decrease (Figure 4).

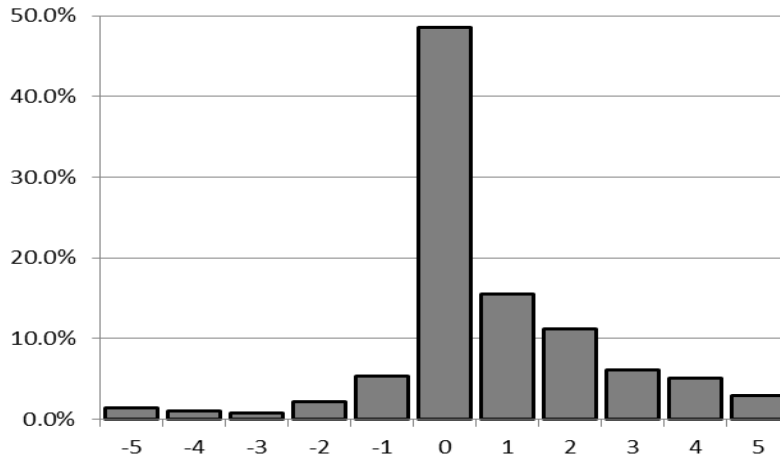

Figure 4. Incremental Change in International Awareness Student Responses

The international experience query with the largest score differentials was:

I have thought about why other countries may have a different perspective than the U.S. on global issues, such as agricultural production, trade, or the environment.

Student responses to this query started out essentially neutral (3.54 average) and increased to general agreement (2.07 average) with 64% of the responses showing an increase. The incremental changes for this query are shown in Figure 5.

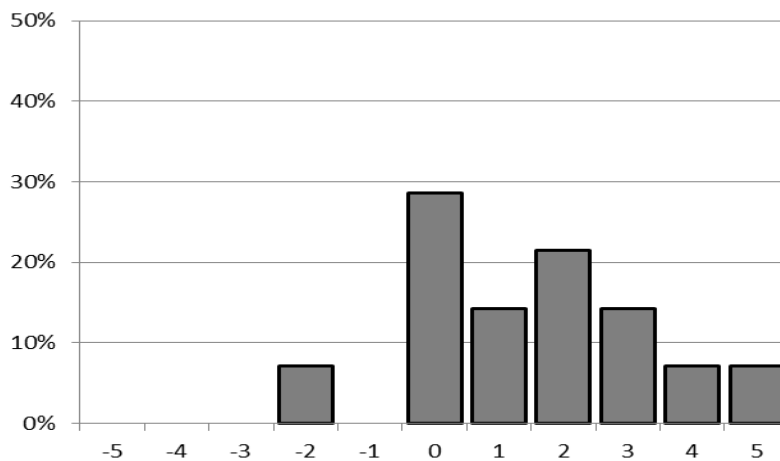

Figure 5. Incremental Change in Perspective of Global Issues Student Responses

Prior to the beginning of the CIE courses students expected the courses to enhance their engineering knowledge (1.8 average) and their understanding of the impact of engineering solutions in a global and societal context (2.11 average). Once again the CIE courses exceeded their expectations and gained in average score by 0.67 and 0.78 respectively. A full 30% of the responses showed positive gains with none showing a negative gain: 83% of the final responses were in the highest category with the remaining 17% of the final responses in the next highest category.

Students generally expect to visit a foreign country in the future (average 1.79 before and 1.20 after), but while returning to continue their educational experiences showed similar gains in scoring (an average increase of 0.61), the final mean score only showed moderate interest (2.93). Working or volunteering in a foreign country does not seem to be in the future for most of the students (average final scores of 2.87 and 3.67).

All survey queries experienced a positive change in student responses except two. “*I am interested in learning more about world geography*” experienced a slight drop of 0.20 while “*I am considering to work in a foreign country*” remained essentially constant (-0.01 differential). Students “somewhat agreed” with each statement resulting in average final scores of ~2.7 and ~2.9 respectively.

Summary

The Compact International Experience course format, as described in this paper proved to be an effective format for the delivery of two senior elective engineering courses: one in France and one in Australia. Despite the short timeframe of delivery, all evidence collected point to an educational experience equivalent in course content and depth of coverage to that of typical semester long courses delivered at the home institution coupled with an enriching international experience. Extremely strong student-faculty interaction was achieved by close-proximity housing accommodations and was a strong factor in successful course delivery.

In summary, the CIE format works well. Course instructors are on call at all times throughout the duration of the course and entirely responsible for the students’ educational and cultural experiences as well as their general wellbeing. Those responsibilities create a workload that is significant by any measure. Without a doubt, both of the instructors feel that the work needed to successfully deliver a CIE format course is worth the investment of time and effort. Each feels enriched by the experience.

Acknowledgement

USD Institutional Review Board approval was obtained for the 2012-13 academic year (Project Number 2012-12-076). F. G. Jacobitz would like to thank Aix-Marseille Université for its hospitality and support. Many members of the institution volunteered to teach technical guest lectures as well as French language and local history lessons to the students. He would also like to acknowledge the support with licensing issues by Comsol. T. F. Schubert would like to acknowledge National Instruments for its support concerning software licensing issues.

Bibliography

1. Institute of International Education, *Open Doors Report*, <http://www.iie.org/en/Research-and-Publications/Open-Doors> (accessed January 31, 2013)
2. Alan Parkinson, "Engineering Study-abroad Programs: Formats, Challenges, Best Practices", *Online Journal for Global Engineering Education 2.2* (2007) <http://digitalcommons.uri.edu/ojgee> (accessed October 10, 2010)
3. Thomas F. Schubert, Jr., & Frank G. Jacobitz, "Compact International Experiences: One Path to Expanding Student International Awareness through Short-Term Study-Abroad Elective Engineering Courses" *Proceedings of the ASEE 2011 Annual Conference*, Vancouver, BC, Canada.
4. Frank G. Jacobitz, F. & Thomas F. Schubert, Jr., "Expanding Student International Awareness through Short-Term Study Abroad Courses with Substantial Engineering Technical Content" *Bulletin of the American Physical Society*, 18th ed., vol. 56, pp. <http://meetings.aps.org/link/BAPS.2012.DFD.L30.8>). San Diego, CA.

The Middle East Initiative – Expanding Education in a Global Context

**Liang Li Wu, Anis Hammoudeh and Gregory Washington
The Henry Samueli School of Engineering, University of California, Irvine**

Abstract

Strengthening education in a global context is the future in an increasingly interconnected world. Programs that can teach students valuable skills in an environment where they can also expand their language skills and worldview will be instrumental in creating the leaders of tomorrow. Research collaborations and international education programs were orchestrated as part of the Middle East Initiative at the Henry Samueli School of Engineering, University of California, Irvine (UCI) with Israeli and Saudi Arabia universities respectively. In this paper, we report our work in progress and results from implementing the Initiative.

Introduction

The world's population is currently approaching seven billion people. This rapid population growth will cause enormous stresses on food, water, energy and natural resources. There will be double the number of Asian style megacities with more than 20 million people. To tackle these challenges, technology has and will continue to play a crucial role to alleviate these stressors. Among all disciplines, the engineering field has experienced the most radical transformation in the last 20 years. For example, telecommunications bandwidth has increased by 100,000 times since the year 2000 and the increase in the number of cell-phone users went from two per 1,000 people in 1990 to over 500 per 1,000 people today. Furthermore, due the globalized market, engineering industries, which cannot compete globally, are not likely to survive domestically¹. To be successful internationally, one is required to have cultural and economic expertise as well as solid technological background. Thus, the engineering education encounters shifting paradigm of how to train our next generation to be global leaders in the field, not only engineering ready, also culturally ready.

While the Henry Samueli School of Engineering was initiating future international programs to educate our students on a dynamic pathway, an incident occurred on campus has altered the direction of international programs and led to the birth of Middle East Initiative. In 2010, Israeli ambassador Michael Oren was invited as a guest speaker at the UC Irvine campus and his speech was continuously disrupted by a group of Muslim students in disagreement on Palestinian issues². This group of Muslim students were arrested and convicted guilty of disrupting the Israeli ambassador's lecture by the Orange County Superior Court. This series of incidents further intensified the existing tension between Israeli and Muslim students on campus. Our campus leadership recognized that punishment would not remedy the hurt and the hatred among the two student groups. It was surmised that through open dialogues with a humble attitude, and the cultivation of collaborations based on technological similarities in a global context, healing can begin. Despite the ethnic and religious differences, our commonality is the challenge we confront on diminishing recourses due to rapid population growth globally. Therefore, under the Middle East Initiative, we have engaged with both Israeli and Saudi Arabia universities in

research collaborations and undergraduate educational programs respectively in partnerships of training future international leaders.

Collaboration with Tel Aviv University (TAU) in Israel

After a delegation visit to Israel in 2012, conversations initiated on a wide range of possible collaborations such as academic exchanges, joint research initiatives, programs and projects between UCI and Israeli universities. During the visit, we discovered a common ground with Tel Aviv University that both universities had excelled in communications and information technology education. UCI is located in Southern California, home to more than 600 telecommunications companies anchored by Broadcom and Qualcomm. TAU is a technological powerhouse in Israel, which has educated a large number of scientists and engineers who have launched companies contributing to making Israel the “start-up” nation. Both schools have shared the vision to teach and educate the best possible engineers giving them a sense of social responsibility.

To elevate the initial relation built during the visit to a more meaningful and engaging interaction, a group of faculty came forth from both universities to organize an international conference called “Communications and Information Technology 2025” (Comm 2025). The conference mission is to present and discuss the issues involved in the higher education of engineers and scientists in the fields of communications and information technology in the year 2025. This conference was hosted jointly and planned through online weekly meetings using Skype – another communication technology that had brought the world closer.

The one and a half day communications conference consisted of morning and afternoon seminars, followed by evening networking sessions. Seminars explore the traditional areas of mobile technologies, micro and nanotechnologies for information processing, and the emerging areas of cloud technologies and embedded systems with presentations delivered by professors from UCI, UCLA, TAU and Technion University. An industry panel was brought together with leaders in the field to discuss from application point of view of how to integrate frontier research work into industry. We had over 140 participants from the academia and industry of Orange County and Greater Los Angeles communities. Since we hoped to use the event as a launching pad for increasing technical learning in a global context, the graduate students from the Department of Electrical Engineering and Computer Sciences, consisting of diverse ethnic backgrounds (many were from the Middle East), were invited. Over 70 graduate students had attended the conference and interacted with professors and industry members.

The inaugural Comm 2025 event served as a great way to bring experts in communications research together to discuss the future of this field. As a result, several research collaborations between UCI and TAU faculty emanated from the conference. Furthermore, the Henry Samueli School of Engineering received recognition from the Orange County Jewish community³ responding positively to the changes we intend to make. The second conference is to take place in Israel Fall 2013, and will build on the concepts we introduced in 2012 and expand to medical innovation technologies.

The Saudi Arabia International Program (SAIP)

Approaching the collaboration from a different perspective, our first Saudi Arabia partner Salman Bin Abdulaziz University engaged in conversations with faculty from our School of Engineering and expressed a keen interest in formulating undergraduate education programs. Therefore, SAIP, hosted by the Henry Samueli School of Engineering, is a collaborative program that seeks to make and strengthen new partnerships through a focused student curriculum. Utilizing the Departments of Civil and Environmental Engineering, Mechanical and Aerospace Engineering, and Electrical Engineering and Computer Science, the aim is to provide international students with extensive English and Engineering training during their stay.

The different modules that make up the year-round experience consist of the Summer Undergraduate Visitor Program (SUVP) and an Academic-Year Undergraduate Visitor Program (AUVP). SUVP brings together English Training, an Undergraduate Engineering Mentorship Experience, and Field Trips and Activities in a 10-Week intensive program. AUVP consists of a full year academic curriculum with the same focus: Intensive English, a Comprehensive Engineering Experience in the students' specific field of study, and cultural activities.

In the initial run of the program, students were not only able to improve their English skills drastically in a short period of time, but they were able to apply them to complicated technical projects and present a symposium of their results all in a language they just began instruction in 10 weeks prior. The overall collaboration formulated under SAIP fosters growth and provides results in a very short period of time. Our program expects much of its students, pushes them to achieve, and invites them to play a part in the international stage of cooperative education.

Implementation of SAIP

During the summer of 2012, 15 students, top of their class from Salman Bin Abdulaziz University, were selected based on many criteria, including but not limited to test scores for general subjects, recommendations from their professors, and proficiency in their English language skills. When running an international program, we have realized that a big part of generating success over the span of the program is providing a welcoming, open atmosphere so the students can flourish in their studies and free time. If the welcome, the housing, the entire living situation produces a negative result, their studies and the integrity of the program will suffer.

After being welcomed and picked up, the students were placed with one other person from their school, and two students from different countries in the other room sharing a common apartment. A good mix of familiarity with the unknown would foster a sense of comfort while encouraging all of the international students to converse in the common language they would all come to learn soon: English. To enhance the students' abroad experiences, a comprehensive cultural program was laid out for them. Developed in house, the cultural experience included many activities to experience American life as an addition to their more rigorous coursework. The success of a program can be measured in both numbers and experience, and for the experience side it was important to the program to let the students delve into as much of the American lifestyle as possible outside of their studies. Cultural excursions included theme parks, bonfires, various

trips to Los Angeles, sports games, etc. Outside of well-planned trips, many suggestions were also made to the students on how to spend their time outside of their coursework.

Also, specific exceptions were made out of the curriculum and schedule due to the student's religious practices. All 15 students were Muslim, and at 5 points in the day, time was made in their schedule to pray. Also, Ramadan, an annual religious observance falling on one month out of the student's time in the United States, was worked around due to the students needing to fast all day, eat after sunset, etc.

The initial program the students would start their second week at the University of California, Irvine would be a comprehensive mix of English and Engineering. English classes would run in the morning, while custom tailored Engineering programs were run in the afternoon. For English, the students took placement exams and were put into varying levels depending on their skills. They were scaled across multiple proficiencies, with some able to hold a good conversation and others unable to converse much. Over the weeks, their English proficiency was dramatically improved by immersing in a diverse ethnic classroom. Even the most hesitant students were able to carry on conversations and convey their thoughts entirely in English. Figure 1 showed that out of 15 students, 12 students have advanced three levels of English based on their final grade.

After the hours of English, the 15 students were split among multiple disciplines in their respective fields, including four programs in Electrical Engineering, Mechanical Engineering, Computer Engineering, and Civil Engineering. Three graduate mentors were hired to work in conjunction with professors providing research guidance. By the end of the program, students would be expected to finish their projects, with variations in grading being determined by measuring the proficiency, accuracy, and effort displayed in completing the tasks. Instruction was given entirely in English, enabling the students to learn at an even quicker rate than before.

After the 10-Week intensive program, students were expected to put together a symposium of their work, and then present at a symposium. Projects including Android development, 3-D printing modules, and software defined radios were on display. The students produced also their own posters for the event, complete with display table for their projects, and were able to convey their project in English while fielding questions from notable members of the Henry Samueli School of Engineering. In addition to this, all students submitted a report detailing their project in a multi-page overview. Their graded scores over the research progress were high, placing them in GPA range for the courses 3.6 and above (as measured by percentage score). Over the percentage score, the students were rated on a satisfactory level equivalent, from S+ to S- as shown in Figure 2.

Most programs that are not connected to a specific graduate program and have a technical focus, such as Engineering, tend to not meld English into their technical program as a requirement; it is not deemed as necessary as the technical work is completed. For SAIP, the cohesion between English and Engineering prepares the students better for graduate programs, giving them the language skills they need in addition to a well-planned technical curriculum to set them on the right track for continued education in the United States. By offering both solutions, this one-of-

a-kind program encourages development on both fronts to empower students to compete in a country that is not their own.

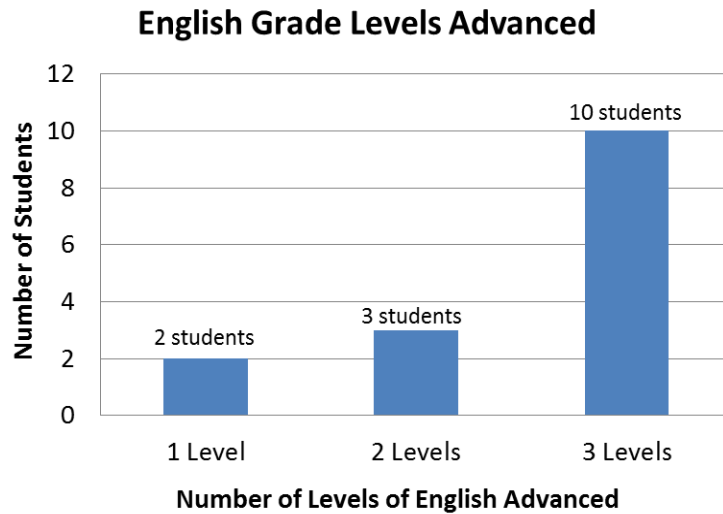

Figure 1. Program result shown by student advancement in English levels. Two students advanced one, three students advanced two and ten students advanced three levels of English.

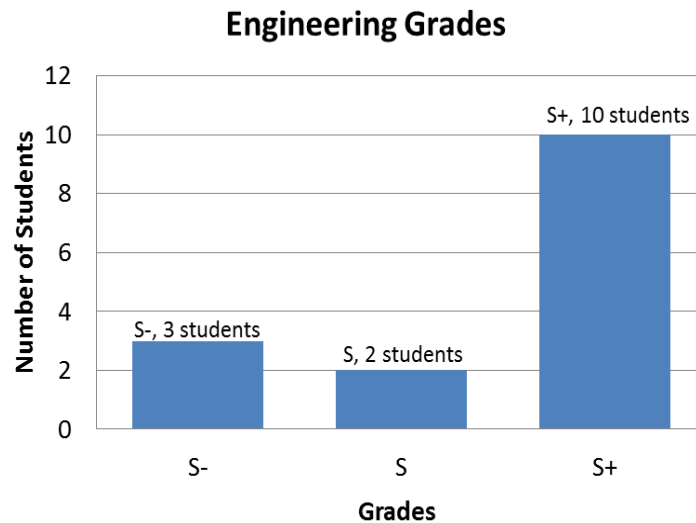

Figure 2. Program result shown by student grades in the research intensive project course. The students were rated on a satisfactory level equivalent, from S+ to S- with three students received S-, two students received S and ten students received S+.

Conclusion

In this paper, we report our work in progress under the Middle East Initiative at the Henry Samueli School of Engineering, University of California, Irvine. Two different types of collaboration approaches were formulated based on mutual interests among the institutions. We have partnered with Tel Aviv University from Israel in research collaboration by organizing an

international conference emphasizing on communication and information technology. We are anticipating the exchange of graduate students among collaborating research groups in the near future. The Saudi Arabia International Program (SAIP) focuses on undergraduate educational program that combines the technical skills of a rigorous engineering curriculum with a comprehensive cultural immersion and English program. Both programs have been piloted and implemented successfully in 2012, and we look forward to expanding the programs with other universities in the Middle East.

Bibliography

1. A. Rugarcia, R. M. Felder, D. R. Woods and J. E. Stice, "The future of engineering education I. A vision for a new century", Chem. Engr. Education, 34(1), 16–25 (2000).
2. Raja Abdulrahim "11 students arrested after disrupting Israeli ambassador's speech at UC Irvine", <http://latimesblogs.latimes.com/lanow/2010/02/11-students-arrested-for-disrupting-israeli-ambassadors-speech-at-uc-irvine-.html>, LA Times, February 9, 2010
3. Florence Dann, "Positive Exchange", <http://www.ocjewishlife.com/site/positive-exchange/>, Orange County Jewish Life, October 2012

WORK IN PROGRESS

Using *Mastering Engineering* Software-Based Homework System in Statics and Circuits Classes

Keith Level

Las Positas College, Livermore, CA

Abstract

Mastering Engineering is a web-based, homework management system, created by Pearson Publishing Company. It is currently available in 4 engineering courses and 2 science courses. Engineering Courses currently covered by the *Mastering Engineering* software include (1) *Statics*, (2) *Dynamics*, (3) *Mechanics of Materials*, and (4) *Electrical Circuits*. This paper will examine the pros and cons of using this software, from a community college perspective, including opinions from both instructors and the students in their respective classes. There will also be some short discussion on possible future uses of software applications like *Mastering Engineering*.

Table of Contents

- A. The Role of Assigning Homework in my Teaching Career
- B. *Mastering Engineering* Overview
- C. How *Mastering Engineering* Works
- D. Grading in *Mastering Engineering*
- E. Types of Problems Available in *Mastering Engineering*
- F. Importing / Exporting Courses / Other Resources
- G. Customizing *Mastering Engineering* to include Instructor's Course Materials
- H. My Recommendations for Instructors who will use *Mastering Engineering*
- I. Upsides to *Mastering Engineering*: Instructor and Student Perspectives
- J. Downsides to *Mastering Engineering*: Instructor and Student Perspectives
- K. Possible Future Trends

- L. Appendix L: Summary of Student Comments re: *Mastering Engineering* in *Circuits*
- M. Appendix M: Example of Submitted *Mastering Engineering* Answer which appears to be correct

A. The Role of Assigning Homework in my Teaching Career

As a community college Engineering instructor my work duties require a wide variety of responsibilities, including teaching up to five different course preparations in one semester. In my 28 years of teaching engineering at the community college level, my approach to assigning, collecting and grading homework in the *Statics* and *Circuits* classes has evolved. When I first started my teaching career, I would typically assign about 10-15 textbook problems every week, collect them on a weekly basis, grade most, if not all, of them by hand (typically with the assistance of a solutions manual, if available). Grading and recording homework, and providing

solutions in a secure manner was a time-consuming activity, and unlike teaching the same course in many university settings, at the community college I had no access to receiving help in grading from graduate students or other people similarly qualified.

Over time, I ended up grading fewer homework problems each successive year, though I would still provide student access to all solutions, either by physically posting solutions on a bulletin board or by posting electronic solutions on a student-accessible website like Blackboard or Moodle. In recent years, this has evolved to where I would still collect the homework, but only check it to see that the student made an attempt to solve the problem, and continue to provide students with solutions to each of the problems that I had assigned. Beginning in Fall Semester 2011, I tried using *Mastering Engineering* for *Statics* for the 1st time, based on a presentation I had seen in the summer of 2011. In the current Spring 2013 semester, I am now using *Mastering Engineering* for the 4th time: twice in *Statics* (Fall 2011, Fall 2012) and now twice in *Circuits* (Spring 2012, Spring 2013). This report summarizes briefly how *Mastering Engineering* works, and also includes both my assessment, and my students' assessments, of the effectiveness of using this web-based homework management system. In my situation, the fact that I no longer personally grade each student's homework, nor spend time recording each student's homework score, has been a significant time savings to me, particularly in large classes.

In both *Statics* and *Circuits*, the homework portion of each course, which now comes completely from the *Mastering Engineering* website, is worth 20% and 15% of the total course grade. In addition, I require a written journal, which should include work completed in answer the *Mastering Engineering* homework questions, and in both classes it is worth between 3-5% of the overall grade (see **Part G., My Recommendations**)

A summary of student comments from my first semester using *Mastering Engineering* (for *Statics*) can be found in Appendix K. The following semester (Spring Semester 2012) I used *Mastering Engineering* for *Circuits*, and I have just completed using *Mastering Engineering* for *Statics* for the 2nd time this past Fall Semester 2012. In each of these classes, the class size has averaged about 28 students per class. In terms of my determining how many problems to assign, I have varied the number of problems per assignment, from about 10 problems on some assignments, up to 25 problems per assignment on others. I recall hearing that Pearson recommended assigning 10-15 problems per assignment, though I personally will assign more problems per assignment if I feel that (a) the problems are shorter, and/or (b) I believe that students need additional practice to master the material.

B. Mastering Engineering Overview

Mastering Engineering is a product, created by Pearson Publishing Corporation, to be used by college faculty and students in a variety of disciplines, mainly within engineering and the sciences. Engineering disciplines currently available in Mastering Engineering include the following:

- Statics
- Electrical Circuits
- Mechanics of Materials

- Dynamics

Other subjects to be added to this list include Materials Science.

On Pearson's *Mastering Engineering* home page, the *Mastering* homework system is advertised the following way: “used by over a million students, the *Mastering* platform is the most effective and widely used online tutorial, homework, and assessment system for the sciences and engineering.” Pearson Publishing is also involved with on-line homework management systems in Mathematics courses, although the software I currently use in teaching Intermediate Algebra--*My Math Lab* ---has a different user (and instructor) interface than that found in *Mastering Engineering*. This paper will solely focus on the *Mastering Engineering* system.

C. How Mastering Engineering Works

Homework assignments are created by the instructor, on the *Mastering Engineering* website (website access to the instructor's site is password protected). When a “course” is created on *Mastering Engineering*, a course number is assigned (for example, in my Spring 2013 Introduction to Circuits Analysis course, the course number was MELEVELENGR44).



Figure 1: *Mastering Engineering Log in Home Page*

All students enrolled in the class are required to sign-up for the *Mastering Engineering* website. Access to *Mastering Engineering* is not free; student options for gaining access to the *Mastering Engineering* site include the following:

1. Students purchasing web-access to *Mastering Engineering* separately, through the *Mastering Engineering* website. In the current Spring Semester 2013, this access costs students approximately \$60/semester for access *Mastering Engineering-Circuits*.
2. Students can purchase either a hardbound or an electronic textbook bundled with web-access to *Mastering Engineering* through the Pearson website.

- If the instructor elects to do so, Pearson also offers the opportunity to bundle a custom-published hardbound textbook, bundled with the Mastering Engineering software. For example, in Spring 2013 I have this option available to students for the Circuits class. I am using only the first 11 chapters of the Nilsson-Riedel Circuits textbook (vs. the entire 18 chapters found in the hardbound textbook). The custom-published textbook (containing 11 chapters of Nilsson-Riedel Circuits, and identical to the chapters found in the full-length textbook), bundled with Mastering Engineering, costs approximately \$110 to Las Positas College students during Spring 2013.

As is also true in a “traditional” approach to assigning/collecting/grading homework, in Mastering Engineering the instructor will assign homework problems, determine due dates, determine whether late assignments will be accepted and, if so, how much deduction will apply to late-submitted assignments. The instructor interface for some of these tasks is shown in Figures 2 and 3.

D. Grading in Mastering Engineering

Mastering Engineering keeps a running score of student grades on all homework questions. At any time within the semester, the instructor can select the Gradebook course link (see **Figure 4**) to view a gradesheet (see **Figure 5**) which shows student scores on all homework problems assigned. There are also several filtering options that allow the instructor to see specific portions of the Gradebook.

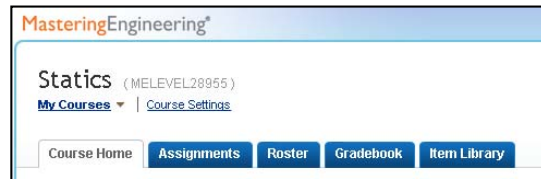

Figure 4: Course Home Links

Gradebook														Manage	View Learning Outcomes Summary
Filter ▾ Showing Score in All Categories for All Students															
Score Time Difficulty															
Students per page: 10															
<< first < prev 1 2 3 next > last >>															
NAME	Chap 1 HW	Intro.ng	Mathem..ew	Ch 2 H.1	Ch 2 H.2	Ch 2 H.3	Ch 3 HW	Ch 4 H.1	Ch 4 H.2	Ch 4 H.3	Ch 5 H.1	Ch 5 H.2	Ch 9 H.	TOTAL	
Essays	--	--	--	--	--	--	--	--	--	--	--	--	--		see all
Assigned Points	12	12	5	6	13	14	11	9	19	7	22	19		244	
Class Average	10.5	9.3	4.2	4.4	10.4	10.2	7.9	6.3	12.2	5.4	14.8	11.0		166	
Student names removed	9.4	10.3	4.8	5.1	10.8	13.0	8.8	8.8	11.0	6.1	15.4	9.9		186	
	9.1	12.0	0.0	4.4	9.8	7.8	5.9	4.9	11.0	3.9	14.3	0.0		148	
	11.9	11.7	4.8	5.9	13.0	14.1	11.0	8.7	19.0	7.0	21.5	18.9	1	243	
	11.6	1.0	4.9	3.9	12.9	13.2	10.6	3.0	17.9	6.7	21.3	13.8		203	
	11.3	11.7	5.0	3.3	10.4	3.5	1.6	1.0	2.8	6.5	16.5	9.5		143	
	10.6	11.0	4.9	4.9	1.0	6.4	1.0	1.0	2.0	0.0	6.0	0.0		69.0	
	6.0	11.0	4.7	3.8	8.3	0.0	0.0	2.0	4.9	3.4	1.4	0.0		64.8	
	11.7	11.0	5.0	5.0	12.2	13.0	10.9	7.7	15.6	5.0	15.5	13.6		201	
	9.3	11.6	4.6	5.5	8.9	11.9	7.9	7.3	12.1	5.0	1.9	8.9		148	
	11.6	11.3	5.0	4.9	12.4	13.3	9.7	8.6	17.7	6.9	20.2	15.4		209	

Figure 5: Example Gradebook, showing individual and total homework grades



E. Types of Problems Available in Mastering Engineering

Mastering Engineering is designed to have two different types of problems for students to solve. (1) **End-Of-Chapter questions** are identical to those found in the most current edition of the hardbound textbook. If students purchase the hardbound textbook bundled with the Mastering Engineering access, they can still potentially work on homework problems without access to a computer. The other type of homework problem, (2) **Tutorials**, are problems which are not available in the hardbound edition of the textbook, and have been marketed to both students and instructors as one of the value-added features to Mastering Engineering (see **Figure 6**). These are typically much longer than end-of-section problems, with multiple parts, and are designed to be more conceptual than end-of-section problems. An example of a Tutorial question from Statics is shown in Figure 6. Tutorial Problems also include a **Hints** feature, where a student can receive additional information to help solve the problem (see **Figure 7**)

Figure 6: Example of Tutorial Problem on Method of Joints, from Statics. Tutorial Problems are not duplicated in the textbook, and typically involve multiple parts, and are intended to build towards a better understanding of a topic.

Figure 7: Tutorial Hint from a Method of Joints Problem, from Statics

In addition to selecting specific problems, the instructor will also be able to view the following items, for each problem. Usage statistics are based on how have previous students have scored on the same problem. Each problem includes an (a) Item Type, (b) Title, (c) Time, (d) Difficulty, and (e) Usage Statistics. An example from an RL Circuit Tutorial is shown below:

Item Type	 <p>Tutorial</p> <p>The icon below Tutorial indicates that problems are <i>randomizable</i></p>	Tutorials are longer problems, and are not available in the textbook
Title	<p>The Natural Response of an RL Circuit</p> <p>In this tutorial, students will learn how to model an inductor under DC steady-state conditions to find the initial current. Students will also learn how to determine the time constant for an RL circuit using the Thevenin equivalent resistance seen by the inductor. Lastly, students will derive an expression for the natural response of the inductor current and use this expression to find other circuit quantities.</p>	A description of the problem or tutorial
Time	31m	How long, on average, students have taken to complete problem
Difficulty	4	Mastering Engineering's Difficulty Rating
Usage Statistics		<p>Green % who answered question correctly</p> <p>Red % who requested the answer (i.e., gave up)</p> <p>Orange Measure of wrong answers per student</p> <p>Yellow Measure of number of requested hints</p>

F. Importing / Exporting Courses / Other Resources

This feature allows an instructor to either (a) share courses that they create, with other instructors, and/or (b) re-use a course used in a previous year or semester. **Figure 8** shows the link from a Statics course, including the option of creating a course, which would lead to a dialogue box shown in **Figure 9**. As the only Engineering instructor at my college, I have only used this 2nd option, though I can see how the first option might be very helpful at colleges with multiple sections of a statics or circuits (or other *Mastering Engineering*-supported) courses. If I elect to use a course from a previous semester, I will still have the option to edit the specific problems that I had assigned before. In any case, I will still have to update due dates for all homework

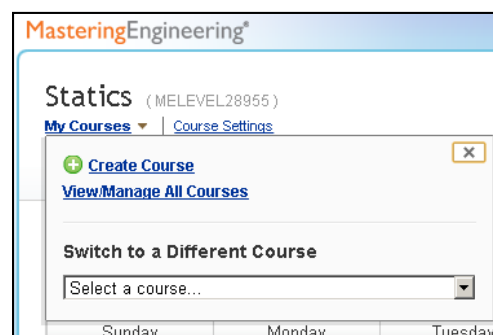

Figure 8: Create or View a Course

problems. **Figure 10** below shows a page used to Manage different courses within Mastering Engineering.

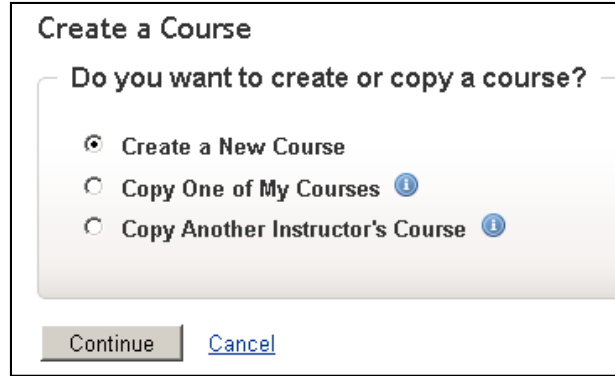

Figure 9: Create a Course Dialogue Box

Manage Courses		
Active Courses		
ACTIONS	COURSE ID	COURSE TITLE
Choose... ▼	MELEVELENGR44	ENGR 44 - Intro to Circuit Analysis (Spring 2013)
Expired Courses		
ACTIONS	COURSE ID	COURSE TITLE
Choose... ▼	MELEVEL28955	Statics
Choose... ▼	MELEVEL80097	ENGR 44 - Intro to Circuit Analysis
Choose... ▼	MELEVEL10733	ENGR 35- Statics (Fall 2012)

Figure 10: Manage Courses Link: Includes Active and Expired courses

Other resources for Instructors include (1) on-line Solutions Manuals, (2) pre-made lecture Powerpoint files, and (3) access to an on-line electronic version of the textbook (see **Figures 11, 12 and 13** below)



Figure 11: Links to Other Instructor Resources

Mastering Engineering: Instructor Resources

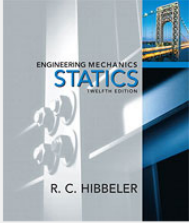

Instructor Solutions Manual

Chapter 1	Chapter 7
Chapter 2	Chapter 8
Chapter 3	Chapter 9
Chapter 4	Chapter 10
Chapter 5	Chapter 11
Chapter 6	Statics Errata

Lecture PowerPoints

Chapter 1	Chapter 6
Chapter 2	Chapter 7
Chapter 3	Chapter 8
Chapter 4	Chapter 9
Chapter 5	Chapter 10

Figure 12: Link to Solutions Manual and Lecture PowerPoints

PEARSON

Browse My Searches Search... Go

Page 103 75%

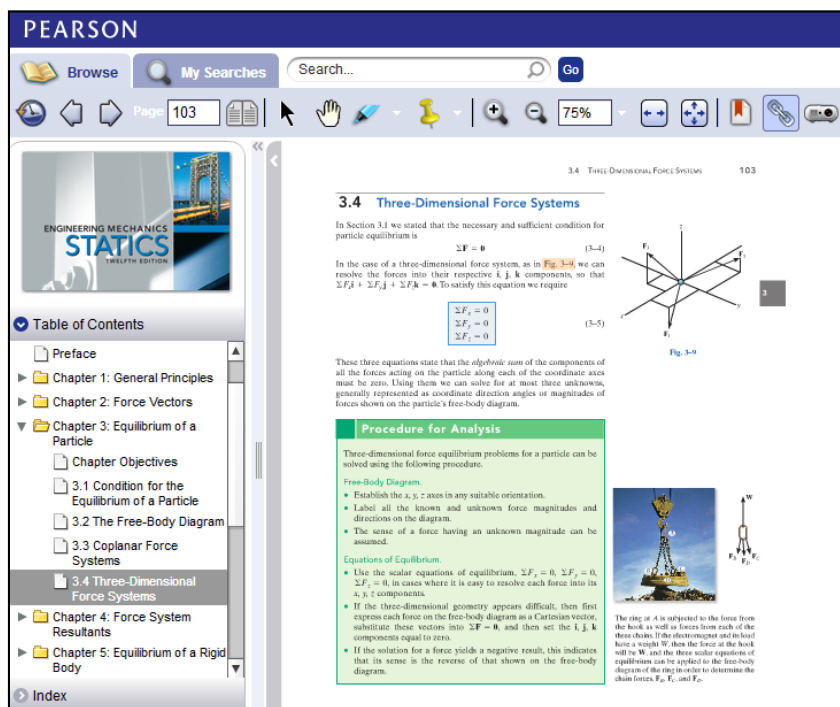

3.4 Three-Dimensional Force Systems

In Section 3.1 we stated that the necessary and sufficient condition for particle equilibrium is

$$\Sigma \mathbf{F} = \mathbf{0} \quad (3-4)$$

In the case of a three-dimensional force system, as in Fig. 3-9, we can resolve the forces into their respective i, j, k components, so that $\Sigma F_x i + \Sigma F_y j + \Sigma F_z k = \mathbf{0}$. To satisfy this equation we require

$$\begin{cases} \Sigma F_x = 0 \\ \Sigma F_y = 0 \\ \Sigma F_z = 0 \end{cases} \quad (3-5)$$

These three equations state that the *algebraic sum* of the components of all the forces acting on the particle along each of the coordinate axes must be zero. Using them we can solve for at most three unknowns, generally represented as coordinate direction angles or magnitudes of forces shown on the particle's free-body diagram.

Procedure for Analysis

Three-dimensional force equilibrium problems for a particle can be solved using the following procedure:

Free-Body Diagram.

- Establish the x, y, z axes in any suitable orientation.
- Label all the known and unknown force magnitudes and directions on the diagram.
- The sense of a force having an unknown magnitude can be assumed.

Equations of Equilibrium.

- Use the scalar equations of equilibrium, $\Sigma F_x = 0, \Sigma F_y = 0, \Sigma F_z = 0$, in cases where it is easy to resolve each force into its x, y, z components.
- If the three-dimensional geometry appears difficult, then first express each force on the free-body diagram as a Cartesian vector, substitute these vectors into $\Sigma \mathbf{F} = \mathbf{0}$, and then set the i, j, k components equal to zero.
- If the solution for a force yields a negative result, this indicates that its sense is the reverse of that shown on the free-body diagram.

The ring at A is subjected to the force from the hook as well as forces from each of the three chains. If the electrocutter and hook had a weight W , then the force at the hook will be W , and the three scalar equations of equilibrium can be applied to the free-body diagram of the ring in order to determine the chain forces F_a, F_b , and F_c .

Figure 13: Link to Electronic Version of Textbook

G. Customizing *Mastering Engineering* to include Instructor's Course Materials

Mastering Engineering does provide a way for instructors to both (a) Upload and record course materials (See Figure 14), and (b) assign their own problems (See Figure 15). In my time using *Mastering Engineering*, I have not yet used either of these features.

Upload and record course materials

The Course Materials feature on the Mastering Course Home lets instructors and [section instructors](#) with the [Course Materials privilege](#) share documents and media with your students. You might consider:

- Recording videos and uploading video and audio files
- Uploading documents such as a syllabus, study guides, labs, or presentations

Students can view or download these materials from their Course Home page. You can make the files available to students immediately, or at a later time.

Note: This feature is *not* meant to be used for adding assignment items to a course. To add assignment items, [import or create items](#) within Mastering.

 [Video: Upload audio and video files](#)







-  [Supported file types and size limits](#)
-  [About folders for your uploaded or recorded files](#)
-  [To upload a document or media file](#)
-  [To record a video file](#)
-  [To make uploaded or recorded files available to students](#)
-  [To play, view, download, copy, edit, and delete files and folders](#)
-  [To upload or record materials once, and copy them to multiple courses](#)

Figure 14: Mastering Engineering Help File on Uploading Course Materials

Custom content: Edit, create, or import items

In addition to using publisher-provided content, you can edit, create, and import your own assignable items.

- [Edit and create assignable items](#)
- [Import your own assignable items](#)
- [Manage items you edited or imported](#)

For information about uploading other course materials, see:

- [Record and upload videos and documents](#)

Copyright © 2013 by Pearson Education. All Rights Reserved.

Figure 15: Mastering Engineering Help File on Adding Your Own Problems

H. My Recommendations for instructors who will use *Mastering Engineering*

1. Consider assigning a written journal as part of the *Mastering Engineering* homework, and make it a percentage of the entire homework grade. This reinforces some of the traditional homework practices that I encourage students to maintain (e.g., drawing free-body-diagrams in Statics).
2. Learn and become knowledgeable about the various settings (e.g., late penalties for homework) that *Mastering Engineering* provides.

3. Be aware that some students may be quite insistent on their dislike of this approach to completing homework (see Appendix K for student comments).

I. Upsides to Mastering Engineering: Instructor and Student Perspectives

1. Frees up a significant amount of paperwork on the instructor's part.
2. Provides students immediate feedback on whether homework solutions are correct, and also has the potential to provide immediate assistance to students working on homework problems.
3. Keeps all grades in a secure location on the Mastering Engineering website, which an instructor can access at any time.
4. Provides the facility to align the goals of homework with Student Learning Outcomes (SLOs).

J. Downsides to Mastering Engineering: Instructor and Student Perspectives

1. Software is 1st or 2nd generation. Students have complained that correct solutions are not always recognized by the software as being correct. An example of one type of inconsistency is shown in Appendix L, where the input (mine, in this case) was not recognized as being correct, even though it appears to be correct.
2. It is unclear whether the actual learning outcomes are an improvement when compared to using a traditional approach to engineering homework. In the courses where I have used Mastering Engineering, I have not observed any significant difference in student performance, when comparing students who completed homework through Mastering Engineering vs. a traditional paper-and-pencil approach. To accurately measure learning outcome differences between using Mastering Engineering vs. using the traditional pencil-and-paper approach would be very challenging.
3. Graphics-based problems. I was advised by another community college instructor to avoid assigning these types of problems. My brief exposure to solving these types of problems has confirmed the advice that I had received.
4. Assignment of computer-based homework problems may discourage students from solving homework problems using the traditional approach of pencil on paper, including appropriate diagrams (e.g., free-body diagrams in Statics). To address this issue, I typically require that students use journals to record their problem solving, collect the journals 2 or 3 times per semester, and incorporate the journal's grade as part of their overall homework grade. This aspect is my first recommendation in Part G.
5. There is no "used-software" market for this product, and, as a result, students have really only one option for accessing the Mastering Engineering software—through the publisher. I have found that, in today's textbook market, many students have been

accustomed to using a variety of internet sources to buy textbooks. Options for students to obtain Mastering Engineering through another vendor are very limited.

K. Possible Future Trends

If the trend in offering distance-education courses (including hybrid courses) continues, then Mastering Engineering and other software systems of its type will likely increase in use. As an instructor who has ample experience in the older, more traditional approaches to teaching Statics and Circuits, I feel that it has potential to potentially improve upon the “old way”, provided it is used and managed carefully.

Appendix L: Summary of Student Comments re: Mastering Engineering in Circuits

Course: ENGR 44, *Introduction to Circuit Analysis*, 4 units, Spring 2012, Las Positas College, Livermore, CA, Instructor: Keith Level

Note: ME represents Mastering Engineering, MP represents Mastering Physics, M by itself or combined with other words will represent any of the different Mastering software programs.

All students were presented with all of the following questions; although each student's name is kept anonymous, each lower case letter, in each answer, represents the same student (this is done to provide some continuity between answers to the various questions).

1. **Summarize any use of “Mastering”-types of homework software prior to this semester, and include your overall opinion of its merits / problems (prior to Spring 2012)**
 - a. Used ME for Statics, Used MP for 3 Physics Classes
 - b. Physics Heat/Light: straightforward, just a bit time consuming
Statics: Not so great graphical problems
 - c. I used Aplia for Economics which was a lot easier to use and well thought out than M softwares that I have used
 - d. It is a good way to have immediate check for correct answer. But, I believe it is very time consuming to change and keep track of the unit prefix, such as μ , m, M, G
 - e. MP: It was pretty good
 - f. ME, MP, MChem
 - g. Decent stuff, the hints on why you got a problem wrong can really help.
 - h. Used MP before
 - i. Used MP in Physics 4A-C
 - j. Very finicky about units, ie, will be marked wrong for 5 nF when the answer is given as 5×10^{-9}
 - k. I used MP for 2 semesters. It was difficult to get used to at first, but eventually I learned to appreciate the benefits of having to spend 2 hours on one problem
 - l. M-type homework that I have done prior to this semester have the same problems I have in this semester. The way it is designed to help student learning on the subject is very weak compared to a software I have to use of Chem 1A, “sapling”
 - m.
 - n. I have used M for two semesters of physics. Both experiences have been awful.
 - o. I have used MP and ME so far. I liked using it because I thought that it was a better way to study than just using the textbook.
 - p. I don't like it at all.
 - q. It is a great idea, just need to fix up glitches.
 - r. MP was done well, all the answers were correct and what you needed to find was clear. ME for statics was also pretty clear.
 - s. MC: Did not have a problem with it. MP: Hard to input values like it wanted it. ME: Graphs and some data entry are confusing.
 - t. Used M for all 4 of my Physics classes plus my statics engineering class. Up to this class, I would give M a fair grade, but this experience I would rate M as unacceptable.
2. **List some of the positive aspects of Mastering Engineering for Circuits this semester:**
 - a. Immediate feedback (that isn't perfect)
 - b. Continuous work
Lengthy tutorials, need to summarize text?
 - c. I can go back to every assignment that I have completed and review it. I can also do all the problems from scratch (for no credit)
 - d. Immediate respond on the correct answer. It forces you to understand the problem, although it could help with more hints in regular problems or example problems.

- e. It tells me whether I have the correct answer right away; hints.
 - f. Immediate feedback; tutorial problems w/hints are generally helpful; orange is my favorite color.
 - g. Homework is graded very quickly.
 - h. Immediate feedback on solved problems which helped speed up the learning process
3. **List some of the positive aspects of Mastering Engineering for Circuits this semester: (continued)**
- i. Gives instant feedback if answer is right/wrong; Multiple attempts to get correct answer; Don't have to wait for the teacher to return work to know your score;
 - j. Immediate feedback; Tutorial problems are useful, but very long
 - k. Having M homework makes it harder to breeze through an assignment, since you have to work so much harder for each little point. You end up spending more time thinking about circuits, which probably increases understanding.
 - l. It covers all theories we need to learn for basic circuits; The video clips by the author helps a lot.
 - m. Forces me to do my homework fully. Gives me on the spot grading, which is very helpful.
 - n. Makes it easy for teachers.
 - o. Easy access to it. Wherever you have the internet, you can study. Tutorials are very helpful.
 - p. The hints help and when the feedback box shows up.
 - q. Most of the hints are helpful. The immediate response is helpful.
 - r. Some of the hints helped figure out the problems.
 - s. It tries to help us see what we are doing wrong and it gives us hints to get the answer correctly.
 - t. Immediate feedback on all problem answers. Hints on tutorials.
4. **List some of the negative aspects of Mastering Engineering for Circuits this semester:**
- a. Rounding / significant figures errors
Entering the answers in the way ME wants it gets frequently frustrating
Entering plotted graphs never match with the key
 - b. Inconsistent units for answers (preferred standard units or Sci Notation), SI units
Do not truncate too much each step of a problem
 - i. Only truncate for sig figs for final answers
 Lack of circuit building diagrams
 - c. All the questions are not of equal difficulty, but are usually worth same points (usually 1 pt), even though some of them have multiple parts
Tutorials are a lot longer and usually tougher than regular problems
If the answer is slightly wrong, most of the time no error shows up, especially with problems that are based on a circuit diagram.
 - d. The instructions are not always clear. It should provide hints on the regular problems, not only the tutorials. Keeping track on the prefix, such as μ , m, M, G
 - e. Rounding errors; When they tell you they are using (ms) for time; Some of the hints are very pointless and don't held at all; Graphs.
 - f. Feedback is not always helpful—difficulty and time ratings are inaccurate; Inputted .785 instead of $\pi/4$, marked incorrect with comment “check your signs”; drawing vectors is terrible; drawing graphs is terrible; some problems have errors.
 - g. Some problems have incorrect answers; sometimes the software says your answer is incorrect when it isn't
 - h. Graphing was very difficult, not much room for error.
 - i. Some correct answer are not accepted by M; At times it won't accept an answer if its not in ms (e.g., e^{-5000t} vs e^{-5t})
 - j. Easy to forget (at least for me); Typing in solution can be painfully slow / difficult.
 - k. I have no problem with spending a long time working on a problem until I understand it completely. However, if I spend that long on a problem and then find out that the first answer I entered was correct after all, I become extremely frustrated. This happened more than once with ME, but never with MP. When emotion over the software is stronger than frustration over learning the material, then it is not an effective tool.

- l. Have to spend more time on unit issue (ie, time is in milliseconds in one problem and in microseconds in another) for the right answer than actually solving the concept of the problem; graphs problems are very time consuming to get right.
- m. Tutorials are outrageously long. Spend sometimes an hour per tutorial. I know it is to learn but an hour reading a computer screen is very, very difficult. If majority of students use TI-83-84 calculators fix your problems to match their rounding. In circuits software the time should stay in seconds, not milli- or micro-. S.o unnecessary
- n. Being asked to give your answers in milliseconds every problem sucks. All of our answers come out in seconds. There is not point making us move decimals. All tutorials created by M suck. Completely removing the tutorials would greatly improve my experience. There are typos on every assignment. Units in general are always finicky. Most of the hints suck.
- o. It sometimes requires too precise answers.
- p. The feedback box doesn't always have helpful hints.
- q. The graphing problems are too glitchy. Significant figures and units are inconsistent. Tutorials have too many parts A-Z excessive.
- r. Answers were wrong. Some of the hints only gave you info that was given in the question. And the sig figs and what must find, not very clear.
- s. Some problems ask for very specific formats when we input them on the computer and even if the answer is correct, we get marked down for it.
- t. Required answering time value functions in different prefixes for equations (milli, micro, etc.). Cannot trust M if my answer is wrong—far too many mistakes on this version of M. 5 or 6 Plus mistakes. Entering functions on graphs is too time consuming and difficult. Some of the tutorials are too long. By the end of the problem you just want to be done, which does not stimulate learning. Possibly make tutorials worth more points.

5. Overall, do you believe using Mastering Engineering for managing the homework in Circuits to be better than the traditional way (paper solutions, collected /graded /returned)? Explain your answer.

- a. Overall, no. ME's issues doesn't help students focus on the actual subject
- b. A bit, because it involves online use to access different parts of the material
Switch picture diagrams per question; speeds up
- c. No, I do not believe ME to be better, mainly because the teacher does not have to grade the assignment personally, which usually results in teacher not knowing how lengthy the problems are.
- d. Yes, it is because it is easier to get immediate respond on answers and scores.
- e. Yes
- f. I haven't done this specific class using the traditional method, would recommend traditional method because ME doesn't give solution to incorrect problems.
- g. Yes and No; I like how the grading is easier and faster for M, but wrong answers and unclear instructions on their end can be quite frustrating. Pros = Cons.
- h. Yes, its faster feedback
- i. Yes, switch up was nice experience.
- j. No, with traditional HW, the professor can show you where you made a mistake (since all the work for the problem is right there AND if it's a small error, it's easier to fix)
- k. No. If it were a more reliable program, then perhaps. The way it is now, dedicated students get frustrated, and not-so-dedicated students either blow it off or copy from the solutions manual.
- l. Not sure but improving the design of ME will be better, in my opinion
- m. Yes, only because of the way I get instant feedback, however useful that feedback may be.
- n. No, never in a million years. Traditional paper solutions would have made my experience in this class much more pleasant.
- o. I think so because we don't have to carry heavy textbooks anymore.
- p. It's both good and bad. I like having hands on HW help from the teacher.
- q. More thorough grading. Quick response.
- r. I think paper would be easier, since it has you show circuits and label your own circuit and voltage directions it would help more.

- s. I find it hard to complete my assignments because it feels very time consuming, I feel like I like the traditional way a lot better.
- t. I do like the immediate feedback aspect of M and not having to wait for the work to be returned. Do homework with M does take more time, usually. More time spent analyzing incorrect problems.

6. You are hired as an advisor to an Engineering Instructor, who has decided to use Mastering Engineering software, but needs guidance on how to use it most effectively. What do you recommend?

- a. Don't use ME in the first place!
- b. "Improve" graphical or vector analysis
Circuit analysis programs
- c. I recommend the Instructor to complete every assignment himself/herself to realize what level of difficulty they are and if they're appropriate for all students.
- d. Not assign too many problems, because they are very time consuming.
- e. Tell students to buy solutions manual, it is very useful to understand how to do problems
- f. No.
- g. Give your students multiple tries on each problem, and don't take off too many points for each attempt. This way students aren't afraid to try if they're not sure about an answer. Give more problem sets with less problems per set.
- h. I would recommend still giving partial credit even after the due date so students are still encouraged to learn the material.
- i. Remove unhelpful / repeated units
- j. Use the problems from the book, don't use the tutorial ones; Don't mark off points for wrong answers, only count correct ones.
- k. The problems take a long time, so don't assign material that you don't intend to test. Don't take off credit for using hints—they're not usually as helpful as advertised.
- l. The software that designing on the website "sapling" learning.com, I had used for chemistry class.
- m. Not due Fridays at midnight but the time the next class starts. I work Friday nights so it is very rushed. Please check the problems beforehand.
- n. Don't use it. If you must use it, never under any circumstances use tutorials. Allow problems to be turned in late for half credit. Do not limit the number of chances you get. Curve everything. Assign less problems.
- o. I don't know how to use it more effectively. I just try to go on the website as many times as possible.
- p. Minimize amount of graphing problems. Try to change units to be all the same.
- q. Minimize tutorials and graphing problems. Require students to record work in a notebook.
- r. I like the intro questions, they gave me a basic understanding of what I need to do. I would recommend they do that first if they need help, but not make it mandatory.
- s. Walk through the program with the students so that they know how to use graphs and how to input values.
- t. Double and triple check the answers before charging students money. Work on the graphing interface to be easier and less intolerant.

7. Other Comments (list on the backside if necessary). Include any HW problems that you believe to have mistakes.

- b. Include a circuit analysis program (3rd party) if necessary
Interactive graphs
- c. Usually when I partially complete a problem and do not have the time to complete it later on (before the due date), I'm not awarded any points for that particular question.
- d.

- e. I honestly like it overall, but there are just a few more issues than can really piss you off.
- f. I hope to be hit by lightning so I do not have to finish M assignments.
- g. SHARE AWAY!
- h.
- i.
- j. It's good for immediate feedback, but having answers in the back of the book is just as useful; If M included a solution, the steps from the start to the solved problem (or until the answer is reached) it would have been MUCH more helpful.
- k. A classmate said it best: "Under any other circumstances, no one would pay \$50 to beta test someone's software for them." Especially when we're busy trying to learn circuits. (1) I wish they would stop messing around with time units. If an equation given in the problem requires time to be in seconds, we should be allowed to enter our answer with time in seconds; (2) In the earlier chapters, M's insistence on using their preferred sign convention in tutorials was more confusing than helpful. It didn't help that the convention they chose seemed backwards compared to the more logical approach we learned in lecture (and in physics). (3) It would be more useful to have hints for the long book problems rather than the tutorials, because the tutorials are already broken up into small parts. (4) That being said, I have found errors in hints as well as final answers. I left comments on the worst ones, but who knows if anyone looks at those? (5) Tutorials are very long and are only worth the same number of points as a normal problem. It does not feel as rewarding to complete a tutorial for just one point, regardless of how much is learned from the problem, when there are 8+ parts to the tutorial.
- l.
- m. Fix the problem difficulty levels for teachers view.
- n. Toward the end of the semester, putting lots of Extra Credit in the M helped. Another problem is that M only gives credit for problems that have all parts either complete or requested. This means, if you only know how to do half of the parts on a problem, you can't get credit for the parts you have done, until you "show answer" on the parts you don't know, so instead of getting half credit on a few problems you didn't quite finish, you get none if you don't "show answer" on the parts you don't know. Also, sometimes I would be working on problems right up until the last minute, and I would finish a problem right at 11:59 and not get credit for it because it was considered late. Due dates need to be more flexible.
- o.
- p.
- q.
- r.
- s. I have found that some problems using the random number generator have the answer to the original values.
- t. Education is about learning and learning requires trust. Trust in the teacher and trust in the material. Trust that the teacher knows the material and will, to the best of their ability, guide the student down the correct path of knowledge. I do not have this trust in this particular ME program. I have used M several times before and did not have anywhere near this level of frustration with the program. While I know to err is human, this product is supposed to be a learning tool, one that is a required purchase, and should not leave the student wondering if the incorrect answer message they receive is because of student error in answering the problem or if M is wrong again. I spend many year diagnosing problems in my previous career so I am no stranger to this process and I believe it is an invaluable skill that everyone should learn, but diagnosing my homework should not have the extra variable of incorrect software in it. I know life is hard and real world does have extra unpredictable variables in it, but I and every other student that has to pay for this program should expect an error free learning tool.

Appendix M: Example of Submitted *Mastering Engineering* Answer which appears to be correct

Part G

Enter the expression $\sqrt{2}\mathbf{i} + \mathbf{j} + \mathbf{k}$, where \mathbf{i} , \mathbf{j} and \mathbf{k} are vectors.

Use the 'vec' button, available in the first template group, to denote vectors. Select the vector and then click on the 'vec' button.

$\sqrt{2}\mathbf{i} + \mathbf{j} + \mathbf{k} =$

[Submit](#) [My Answers](#) [Give Up](#)

Try Again

The correct answer does not depend on the variables: i, j .

Example of apparently correct problem submission, interpreted by the software as incorrect. The main issue turned out to be how specifically the vectors were inputted, which ultimately was corrected. From the students' perspective, if an answer looks correct, is marked wrong by the software, should be graded as being correct. The mistake in this instance was inputting the vectors \mathbf{i} , \mathbf{j} and \mathbf{k} without hitting the **vec** button first.

Submitted Answers

ANSWER 1:

$\sqrt{2}\mathbf{i} + \mathbf{j} + \mathbf{k} = \sqrt{2}\mathbf{i} + \mathbf{j} + \mathbf{k}$

The correct answer does not depend on the variables: i, j .

ANSWER 2:

$\sqrt{2}\mathbf{i} + \mathbf{j} + \mathbf{k} =$

The correct answer does not depend on the variable: \mathbf{k}_{vec} .

ANSWER 3:

$\sqrt{2}\mathbf{i} + \mathbf{j} + \mathbf{k} = \sqrt{2}\mathbf{i} + \mathbf{j} + \mathbf{k}$

There is an error in your submission. Make sure you have formatted it properly.

[Return to Current Item](#)

Part G

Enter the expression $\sqrt{2}\mathbf{i} + \mathbf{j} + \mathbf{k}$, where \mathbf{i} , \mathbf{j} and \mathbf{k} are vectors.

Use the 'vec' button, available in the first template group, to denote vectors. Select the vector and then click on the 'vec' button.

$$\sqrt{2}\mathbf{i} + \mathbf{j} + \mathbf{k} = \sqrt{2}\mathbf{i} + \mathbf{j} + \mathbf{k}$$

Submit

[My Answers](#) Give Up

Correct

The correct submission to the original problem discussed and shown above.

Active Learning in Computer-Aided Engineering Courses (WIP)

Tammy Yut-Ling Chan, Gustavo Borel Menezes
Mechanical Engineering Department/Civil Engineering Department
California State University, Los Angeles (CSULA)

Abstract

The field of numerical methods in engineering is broad with many established concepts, yet is still an area of active research. With the short 10 weeks in the quarter to teach this material to undergraduate students, the instructor is faced with issues such as the number of topics, depth of coverage, and how to effectively teach this large amount of material. Herein, the instructors used active learning and project-based approaches to teach students how to solve engineering problems with widely available computer software (MATLAB, Microsoft Excel) in undergraduate upper-division technical elective courses in the mechanical engineering and civil engineering departments. The instructors taught the most popular and useful numerical methods in depth by engaging and assessing students with course lecture, projects, presentations, programming, and report writing. In this pilot course, students worked in teams throughout the quarter to produce the final deliverables – a course manual and a final presentation highlighting the features of their manual (sales pitch). Every two weeks, students turned in work that formed the basis for a chapter and received instructor feedback to improve their work throughout the quarter.

Key features of the courses included: 1) Dedicated class time was dedicated for students and instructors to work together; 2) Teamwork enabled students, under time pressure, to analyze engineering problems, formulate solutions, program, write, and prepare presentations; 3) Engineering problems were solved with widely-available software; and 4) Teams competed to produce the best course manual for next year's course.

Preliminary results from surveys showed that students felt more confident and knowledgeable when presenting technical information, writing their reports, and using computer tools in their subsequent courses. They also used these skills later in their senior design projects. Compared to their peers who did not take this course, these students performed better in their senior design capstone oral presentations, according to surveys in which viewers rated how well students met ABET learning objectives. This work in progress (WIP) is currently collecting and analyzing more survey results to further demonstrate that active learning techniques improve student learning and retention of knowledge/skills.

Introduction

California State University, Los Angeles (CSULA) is a federally designated Title III and Hispanic Serving Institution (HSI) and was the first four-year public institution in the state to be

a full member of the Hispanic Association of Colleges and Universities. Over half of the undergraduate population (53%) is underrepresented minorities, of which 45% are Latino.

CSULA operates on the quarter system with three quarters, each with 10 weeks of instruction, in an academic year: fall (September-December), winter (January-March), spring (March-June). The College of Engineering, Computer Science and Technology (ECST) includes the Departments of Mechanical Engineering, Civil Engineering, Electrical Engineering, Computer Science, and Technology.

The curricula for the B.S. Degree in Mechanical Engineering and the B.S. Degree in Civil Engineering, which are ABET-accredited, are 193 credit hours, which include university and general education requirements. For mechanical engineering, the major requirements are 146 credit hours, of which 25 are upper division technical electives. For civil engineering, the major requirements are 145 credit hours, of which 17 are upper division electives.

The mechanical engineering course, ME 419: Computer-Aided Mechanical Engineering is an upper division technical elective for undergraduates and graduate students. The civil engineering course, CE 380: Numerical Methods is a required course. The maximum number of students in each course is restricted to the number of computers in the classroom, 24. Each course was taught twice per week, each session lasting 100 minutes. The prerequisites for both courses are similar: theory of applied mathematics/numerical methods and computer programming.

Both instructors collaborated extensively in developing the active learning format, with the goals of improving student learning and knowledge/skills retention, for both courses. Explaining ME 419 also describes CE 380, except for some differences in assessment noted later. The assessment for CE 380 is still being developed as a work-in-progress (WIP).

The field of numerical methods for engineering is broad with many special topics. Given the limited time of 10 weeks for instruction, the instructors chose to limit the number of topics to the most popular and useful ones that can be implemented with widely available commercial software such as Microsoft Excel and MATLAB. Because the course prerequisites covered numerical methods theory and computer programming, emphasis in ME 419 and CE 380 was on properly formulating the engineering problem, choosing the appropriate numerical method, and employing a suitable software tool. To further encourage students to delve more deeply in solving the engineering problems, students engaged in active learning methods such as writing reports, programming code, working in teams, presenting solutions, and self-learning new techniques and methods.

These active learning activities also were expected to help students improve in professional and technical skills identified as weak in prior feedback surveys from industrial representatives (employers), alumni, and faculty. These soft skills included teamwork, communication, presentation, writing, and ability and desire to engage in life-long learning. With active learning activities, it was expected that students would have really learned these skills by demonstrating them in later courses and in their professional careers.

Background: Active Learning

Active learning is a broad term that describes many activities that engage students in the learning process. Such activities include collaborative and cooperative learning (teamwork) and problem-based learning (PBL)¹.

Active learning also prepares students to creatively think on the job². In an introductory chemical engineering course with multiple sections, some taught with active learning methods and others with traditional lectures but with the same exams simultaneously administered, students with low GPAs in the active learning class performed better than low-GPA students in the traditional classes³.

Although active learning activities have been shown to be effective at engaging students in the learning process, many engineering programs have not adopted this teaching style. Reasons include reluctance of faculty to learn new teaching methods, mismatch between active learning techniques and learning styles for instructors and students, and lack of administrative support⁴. Nevertheless, several examples of active learning methods have been successfully implemented. MIT's Department of Aeronautics and Astronautics, for example, overcame such challenges in using active learning in the curriculum with strong institutional support, faculty team teaching, careful planning with faculty involvement, and training on active learning methods⁵.

Careful planning also minimizes time in preparing active learning activities. Texas A&M University developed a series of in-class exercises in an upper-division course in biological and agricultural engineering, which required 30 minutes of preparation time and were easy-to-grade⁶. Sert⁷ developed a software tool for engineering students to learn and apply numerical methods and can be used by teachers to develop new problems and prepare assignments.

When choosing active learning activities, a variety of assignments need to be implemented so that students can utilize their strongest learning styles and instructors comfortably and effectively teach. Nickels⁸ discusses his personal experience in adapting active learning methods to suit instructor's teaching styles, course organization and plans. Dimerel⁹ successfully used a "workbook strategy" by providing a workbook, group activities, and use of the Blackboard course management system to address mismatches between learning styles and activities. Marshall¹⁰ describes "differentiated instruction," or universal design, which is a style of teaching and learning based on neuroscience of how the brain learns.

Also, not all students enjoy active learning in the classroom because of their unfamiliarity with this teaching format. At three universities in Texas, feedback from over 150 students showed that students' opinions about active learning varied widely, depending on their learning styles, institutional experience with active learning, and general understanding of course content¹¹. Bagchi et al.¹² observed similar results in using active learning activities in several computer engineering and computer science courses at Purdue University and recommended that active learning activities be broad enough to accommodate different students' learning styles and academic caliber.

Active learning using computer tools has been successfully used in teaching computer-based courses such as computer programming and applied numerical methods in engineering^{13,14}.

However, the use of computers for active learning in the classroom poses certain challenges¹⁵. At Arizona State University, for an electrical circuits class, students were easily distracted with internet/on-line entertainment (web-surfing, chat rooms, email), frustrated with the limited software selection and unfamiliarity of the course format. Instructors had few choices in textbooks utilizing computer technology.

However, careful course planning and explanation to students on how the course is structured ensure that students benefit from actively learning with computer tools. Carter¹⁶ and Furse¹⁷ had students view on-line lectures prior to attending class, during which students were assessed on the content and then completed related assignments together. Enszer et al.¹⁸ emphasized teaching problem solving skills and encouraged students to choose appropriate numerical methods algorithms and software to solve complex chemical engineering problems. Pai¹⁹ found that students who participated in the online quizzes and discussion forums, which were implemented on Blackboard Vista course management system, performed better on the midterm and final exams than their peers who did not engage in these activities. Active learning in mechanical engineering has been promoted using on-line course management tools such as mailbox and discussion forums²⁰.

Problem-Based Learning

Engineering is essentially problem solving. Active learning methods that involve solving problems allow students to practice being engineers²¹. Also, engineers in industry work on case-oriented projects, such as those used in law and business, which have helped students deeply learn engineering principles²². Graduate students in a civil engineering structural dynamics course benefitted from active learning with teamwork and problem-based and project experiences²³.

Cooperative Learning/Teamwork

Engineers work in teams. Teamwork is an active learning method that many students enjoy and find beneficial. Groups of students in an electrical engineering course enjoyed presenting solutions on the board while interacting with the instructor and classmates²⁴. Students also enjoyed discussing engineering ethics in groups²⁵.

In addition, successful cooperative learning or teamwork requires that students be accountable to their peers. Students who focus on being good team players become self-directed, autonomous learners²⁶. Peer evaluations in a civil engineering course revealed that soft skills such as teamwork enhanced learning technical and engineering skills²⁷. At an ABET-accredited engineering program in Saudi Arabia, engineering students learned fluid mechanics better when working in groups than from attending only lectures²⁸. Teamwork also improves students' communication skills²⁹.

Communication: Writing and Presentation

Writing as an active learning method has been proven to foster critical thinking and deeper learning in engineering courses^{30,31}.

Doing presentations is another way for students to actively learn to be better communicators. Groups of graduate students presented their numerical models using MATLAB and Microsoft Excel for the production of a pharmaceutical-grade drug³². In a biomedical engineering design course, groups of students learned professional skills such as effective teamwork and presentation (to clients) in addition to using technical engineering skills on design problems³³. In an engineering strength of materials class, students viewed lecture content outside of class on-line, so that class time was used for presentations and teamwork to solve complex problems³⁴.

Senior Design

Active learning also promotes the deep understanding of engineering and technical knowledge required of students to successfully design solutions to problems encountered in the senior capstone design experience³⁵. The senior design capstone experience prepares students to be engineers on the job.

Hamade and Ghaddar³⁶ used active learning techniques in a series of courses leading up to the design of a micro car for a university competition. Successful students became adept at self-learning technical knowledge, worked effectively in teams, and improved their communication skills. Roemer et al.³⁷ taught professional and engineering skills using the SPIRAL approach that distributes learning design principles in a series of prerequisite courses for the senior design capstone experience.

Learning Objectives

Feedback from alumni, faculty, and industrial representatives (employers) show that recent graduates from the CSULA ECST engineering programs struggle with working in teams and communicating technical material in their presentation and reports. ME 419/CE380 were structured as a project for students to complete with learning objectives that served multiple purposes:

- Teach students difficult technical material by focusing on formulating engineering problems to be solved using computer programs (MATLAB, Microsoft Excel) to distinguish this course from a typical advanced mathematics or computer programming course
- Teach students professional skills (communication and teamwork) (abet g and abet e)
- Engage students in active learning (presenting, writing, programming)
- Assess how well they are learning (good writing, correct calculations/programming, and clear and concise presentations)
- Encourage self-learning (points given for presenting or writing about new material)
- Promote excellence, ownership, and pride in their work by competing to produce the best course manual to be used in future courses

Course Structure

Teams were assigned during the 1st week of classes. 5-6 team leaders were selected based on nominations and popular vote among students. Each team leader drafted up to 4 team members from the remaining students. Students stayed with the same team members throughout quarter. Attendance was mandatory since all work was done in class with the instructor and team members.

Every 2 weeks, a new engineering problem was tackled, with focus on using a numerical method. Table 1 shows the numerical methods covered:

Table 1: Numerical Methods Schedule of Topics and Engineering Problems		
2-Week Cycle	Topic	Engineering Problems
Weeks 1-2	Roots of Equations	Transcendental Functions, Thermodynamics Equations of State – Redlich Kwong and Ideal Gas Law
Weeks 3-4	Linear Algebraic Equations	Heat Capacity, Polynomial Constants, Truss
Weeks 5-6	Optimization, Graphing	Multidimensional Constrained & Unconstrained Optimization, Airfoil Drag, Drum Design, Fuel Additive Design
Weeks 7-8	Numerical Differentiation and Integration	Area of California, Jet Landing Distance
Weeks 9-10	Ordinary Differential Equations	Pendulum

Each 2-week cycle of work comprised a chapter in the final deliverable due at the end of the course: a Reference Manual. On the first day of the 2-week cycle, the instructor gave a 20-60 minute lecture presenting the engineering problems and demonstrating key features of the software (MATLAB and Microsoft Excel) and the on-line help. On the second and third days in class, students worked in groups to formulate the engineering problems, implement/code in Microsoft Excel and/or MATLAB, solve the problems, write the report, and prepare the presentations. On the last day (day 4), team leaders submitted onto Moodle, a course management system, the team's report, presentation, and MATLAB codes/Microsoft Excel spreadsheets of the solutions. All students submitted onto Moodle a peer evaluation of their

teammates. Then each team did their 5-minute presentation using Microsoft PowerPoint or other presentation media.

In addition, a final peer evaluation was required for work in preparing the final deliverable and final presentation. Final presentations were on the last day of class. Each team had 10 minutes to present the key features of their Reference Manual.

Grading Policy

The grading policy was broken down as shown in Table 2. Students on the same team received the same grade for the group assignments: Solutions and Code, Reports, Presentations, and the Final Deliverable. The only grading criterion differentiating students within a team is their performance evaluated by their teammates in the peer evaluation.

To encourage good teamwork, students were held accountable to their teammates by evaluating their team members in the peer evaluation form. Students failing to submit a peer evaluation did not receive their peer evaluation points (up to 10% of their grade). Students also were given their evaluations as constructive feedback to improve their performance. The peer evaluation forms also gave the instructor insight on the health of each team.

Detailed guidelines and rubrics for the reports, presentations, and peer evaluations were given to the students. To motivate students to self-learn, extra points were awarded for presenting new software, tools, programming tips/tricks.

Table 2: ME 419 Grading Policy

Assignment	%
Attendance	5
Peer Evaluations	10
Group Solutions and Code	15
Group Reports	15
Group Presentations	15
Final Deliverable (Reference Manual)	20
Final Presentation (Microsoft PowerPoint)	20

Assessment

Assessing the effectiveness of the active learning methods was in two parts. At the end of the quarter, students gave their opinions on the course and the instructor and on the use of Moodle. This information was collected to understand if students enjoyed active learning.

The second part assessed if the active learning techniques worked to help students more deeply understand the material and improve their professional skills. For ME students, their performances on the senior design capstone oral presentation were compared to those of students who had not taken ME 419. The senior design oral presentation is given by each senior design team (4-6 students per team) in a celebratory event, Senior Design Exposition, at the end of the academic year. Students, faculty, staff, industrial representatives, and other guests attend this event to view and support students' design projects. These participants give feedback on each

team's performance in the senior design oral presentation by filling out a survey in which they rate how well each team achieved ABET learning objectives.

Results: Student Opinion Survey for ME 419 (Winter 2010, Winter 2012)

In Winter 2010, 18 students filled out the university-wide student opinion survey. In Winter 2012, 17 students filled out the same survey. Students were generally satisfied with the ME419 course, as shown in the average of their responses (>3.5/5.0) to the survey questions in Figure 1 and Table 3. Students thought the ME 419 course contributed to their intellectual growth and/or helped them develop useful skills (Q10, Question 10). Students also felt that the assignments were useful (Q2 and Q3, Questions 2 & 3).

However, students in the Winter 2012 thought the instructor failed to give them timely feedback (Q4, Question 4), which was caused by serious issues with using Moodle. The university learning center was still troubleshooting issues with Moodle at that time, including problems with students and instructors uploading and returning assignments. The Moodle optional survey was given to determine how much Moodle affected students' opinion of the ME 419 course.

Some students in Winter 2012 also commented that the instructor needed to more clearly present the material by giving more lectures and teaching programming mechanics, which were not the objectives of the course as outlined in the syllabus. Such comments reflect that some students do not enjoy active learning methods, as they may not suit their learning styles.

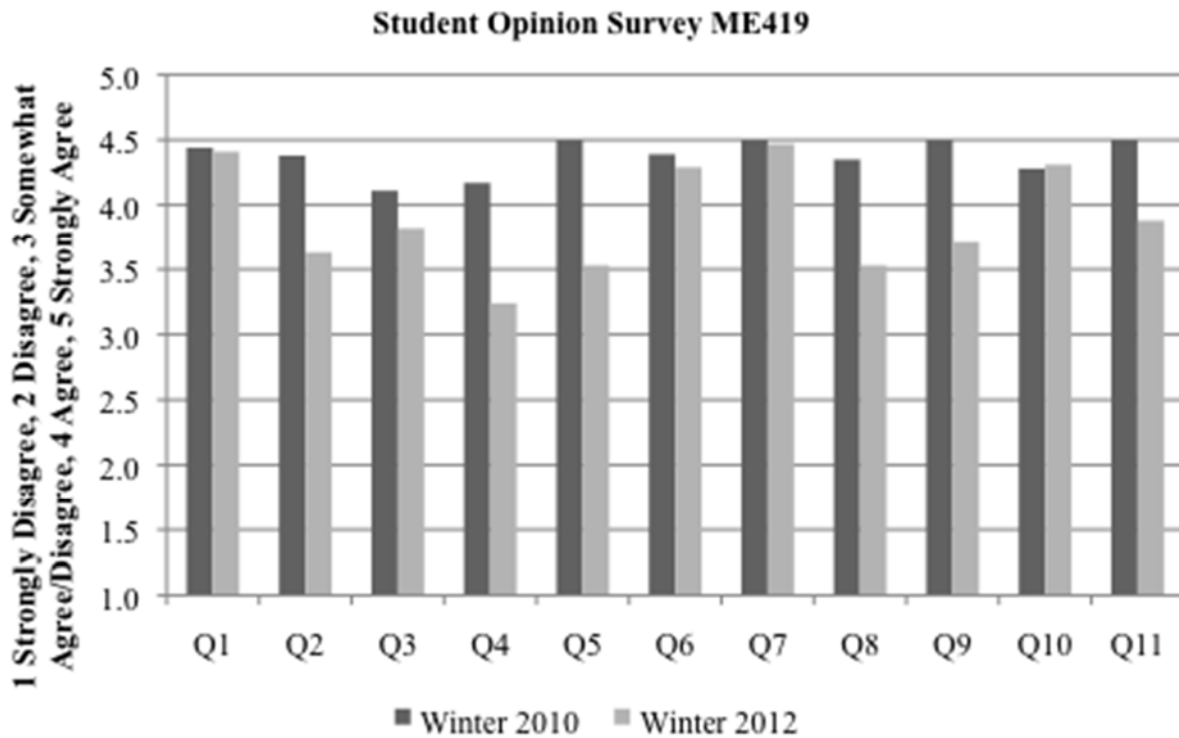

Figure 1: Average Responses to the Student Opinion Survey for ME 419

**Table 3: Student Opinion Survey Questions. Responses scaled as follows:
1 Strongly Disagree, 2 Disagree, 3 Somewhat Agree/Disagree, 4 Agree, 5 Strongly Agree**

	The University-Wide Questions:	Agree > 3.5	Neutral 2.5 to 3.5	Disagree < 2.5
Q1	The course syllabus clearly stated course objectives, requirements and grading criteria.	x		
Q2	The readings and assignments contributed to my understanding of the subject.	x		
Q3	Exams, projects, papers, etc. were good measures of the course material.	x		
Q4	The instructor provided timely feedback about my performance in the class.	x	x	
Q5	The instructor clearly presented the subject matter.	x		
Q6	The instructor was well prepared.	x		
Q7	The instructor demonstrated knowledge of the subject matter.	x		
Q8	The instructor was accessible to provide requested help in the subject.	x		
Q9	The instructor was respectful and unbiased when interacting with the students.	x		
Q10	The course contributed to my intellectual growth and/or helped me develop useful skills.	x		
Q11	Overall the instructor was an effective teacher.	x		

Results: Moodle Survey for ME 419 (Winter 2012)

Using Moodle was new for the Winter 2012 section of the ME 419 course. Difficulties with using Moodle during this trial period at the university potentially affected how students learned. Students and the instructor experienced difficulties in uploading and returning assignments in Moodle. This optional survey was given to students to determine if they still benefited from the course.

Most students (14 out of 17) filled out this optional survey. In Figure 2, the light grey bars represent questions (Table 4) for which students were neutral (somewhat agree/disagree).

However, the following conclusions, each represented by questions in the same color bar, are:

- Students liked group work (Q1, Q2, Q5, Q6, Q7, Q14-Q19) – Dark Grey Bars
- Students liked learning software Microsoft Excel, MATLAB (Q22, Q23, Q29-Q33) – Black Bars
- Students found the active learning activities such as writing and presentations were useful (Q24, Q25) – White Bars
- Students were unable to complete all the activities in class (Q26) – Narrow Striped Bar

Based on these conclusions, most of the students enjoyed the active learning activities, despite issues with using Moodle.

As for using Moodle, students slightly disagreed with how easy it was to turn in assignments in Moodle. As shown in Figure 1 and Table 3, students did not feel that they were given adequate feedback in time, which was caused by issues with Moodle in uploading and returning assignments.

ME 419 Winter 2012 Moodle Survey Results

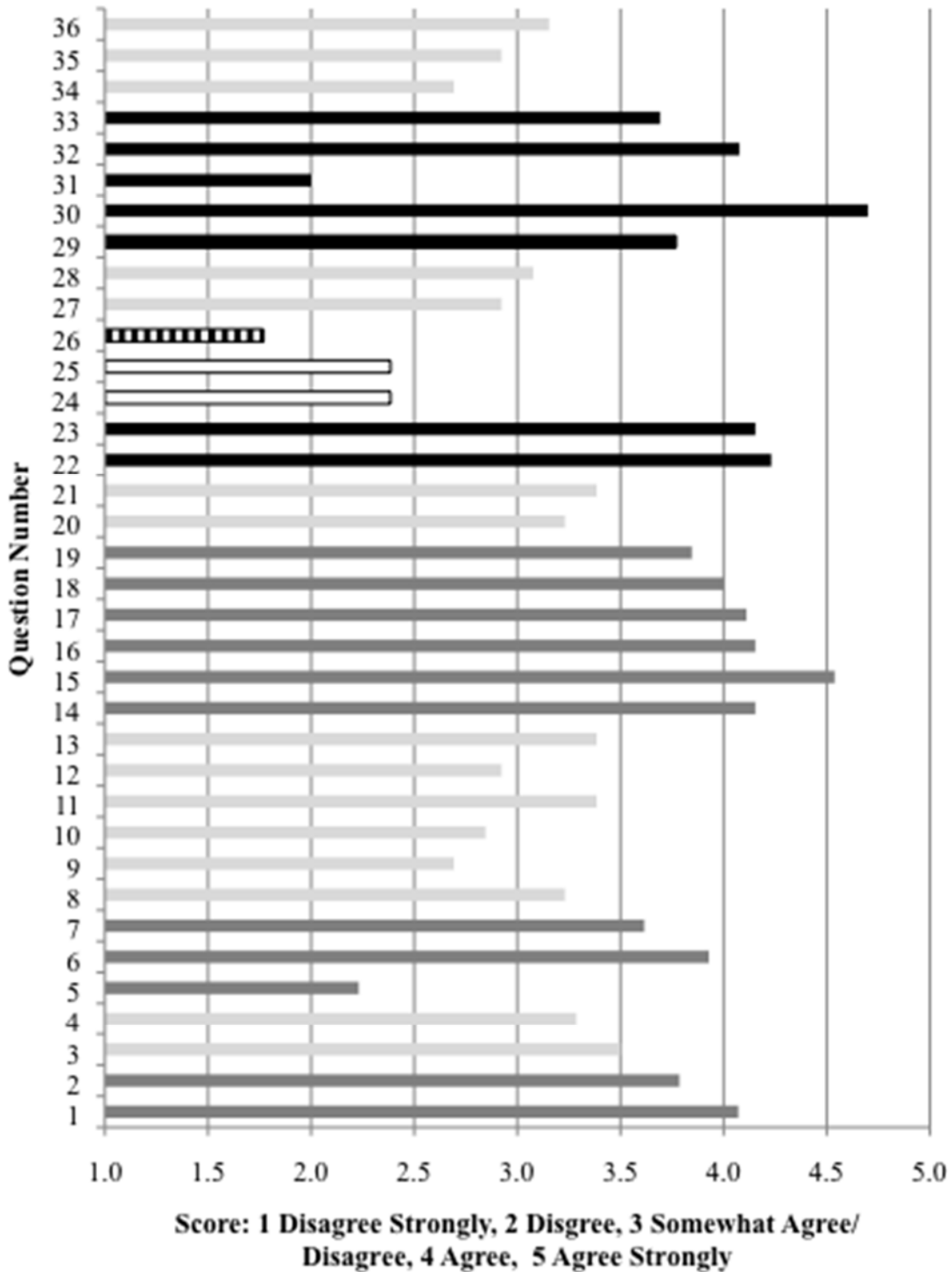

Figure 2: Average Responses for the ME 419 Winter 2012 Moodle Survey. Each color supports a conclusion.

**Table 4: ME 419 Winter 2012 Moodle Survey Questions. Responses scaled as follows:
1 Strongly Disagree, 2 Disagree, 3 Somewhat Agree / Disagree, 4 Agree, 5 Strongly Agree**

	Question	Agree > 3.5	Neutral 2.5 to 3.5	Disagree < 2.5
Q1	I like doing group work.	x		
Q2	I would like to do more group work in the engineering classes.	x		
Q3	I like ME 419 alot because of this group activity.		x	
Q4	I prefer doing work by myself.		x	
Q5	It was confusing to work in a group.			x
Q6	I liked doing the assignments as a group.	x		
Q7	My group spent a lot of time together on the assignments.	x		
Q8	I did some of the assignments by myself.		x	
Q9	My group grades were fair.		x	
Q10	My grade in the class would be higher if I had worked alone.		x	
Q11	My group grades would be lower if I did the work by myself.		x	
Q12	It would have been better to pick my group members.		x	
Q13	Our group grades would be higher if we had worked more together.		x	
Q14	Group member 1 was helpful.	x		
Q15	It was easy to contact Group member 1.	x		
Q16	Group member 2 was helpful.	x		
Q17	It was easy to contact Group member 2.	x		
Q18	Group member 3 was helpful.	x		

**Table 4: ME 419 Winter 2012 Moodle Survey Questions. Responses scaled as follows:
1 Strongly Disagree, 2 Disagree, 3 Somewhat Agree / Disagree, 4 Agree, 5 Strongly Agree**

	Question	Agree > 3.5	Neutral 2.5 to 3.5	Disagree < 2.5
Q19	It was easy to contact Group member 3.	x		
Q20	I liked writing the reports.		x	
Q21	I liked doing the presentations.		x	
Q22	I liked learning how to better use Microsoft Excel.	x		
Q23	I liked learning how to program in MATLAB.	x		
Q24	Writing reports was a waste of time.			x
Q25	Doing presentations was a waste of time.			x
Q26	All the work was easily completed during class time.			x
Q27	Writing reports helped me understand the material better.		x	
Q28	Doing presentations helped me understand the material better.		x	
Q29	I would have learned the material better if I had spent more time programming rather than writing reports and making presentations.	x		
Q30	At the beginning of the quarter, I did not know MATLAB.	x		
Q31	At the beginning of the quarter, I already knew MATLAB.			x
Q32	Now I understand Microsoft Excel more.	x		
Q33	Now I can program in MATLAB.	x		
Q34	Moodle made it convenient to turn in assignments.		x	
Q35	Moodle helped organize course information.		x	

Table 4: ME 419 Winter 2012 Moodle Survey Questions. Responses scaled as follows: 1 Strongly Disagree, 2 Disagree, 3 Somewhat Agree / Disagree, 4 Agree, 5 Strongly Agree

	Question	Agree > 3.5	Neutral 2.5 to 3.5	Disagree < 2.5
Q36	It was very easy to learn how to use Moodle		x	

Results: 2012 Senior Design Oral Presentation Survey

At the 2012 Senior Design Exposition, collected were 375 senior design oral presentation survey responses from students, faculty, industrial representatives and other constituents. Other constituents included guests and university staff personnel. Shown in Table 5 are the 14 senior design teams that were evaluated with the survey. A total of 11 ME 419 students were on 8 senior design teams. The teams with closed sessions had projects of a confidential nature, which severely limited the number of people who had permission to view their presentations and submit a completed survey.

Table 5: Number of ME419 Students in 2012 Senior Design Teams

Presentation		Number of ME 419 Students
1	DirectTV	
2	Raytheon	
3	CEaS	
4	EcoCar-ME (competition)	1
5	EcoCar-EE (competition)	
6	SAE Formula (competition)	
7	DPTint - Closed Session	1
8	DRI Impactor	2
9	SAE Baja (competition)	3
10	SAE Aerodesign (competition)	
11	ASME Human-Powered Vehicle (competition)	1
12	Boeing - Closed Session	1
13	SAE Supermileage (competition)	1

14	Marisol Walker	1
----	----------------	---

As shown in Figure 4 and Table 6, on nearly all of the ABET learning objectives (except ABET b), the teams with at least one member who had taken ME 419 (ME 419 teams) performed better than other teams which did not have members with ME 419 experience (non-ME 419). However, for ABET learning objectives a and b, engineering analysis, testing, and verification, the results from ME 419 and non-ME 419 members were comparable. For 2011-12 senior design, about half of the projects (7/14) were competition projects, which emphasize rapid prototyping and fabrication of a vehicle to meet the competition schedule and less on research, analysis, and testing (ABET a and b).

Notably, ME 419 student teams performed overwhelmingly better on communication (ABET g), design (ABET c), societal issues (ABET h), teamwork (ABET e), professionalism (ABET f), and knowledge of contemporary issues (ABET j). These learning objectives were emphasized in the ME 419 course, especially teamwork, communication, and professionalism. It is assumed that these students had not taken prior courses/classes in communication and professionalism, as they are not required in the mechanical engineering curriculum. Also these students were told about the active learning format of the course on the first day of class, and only two graduate students dropped the course because they had previously studied the material/topics in other courses.

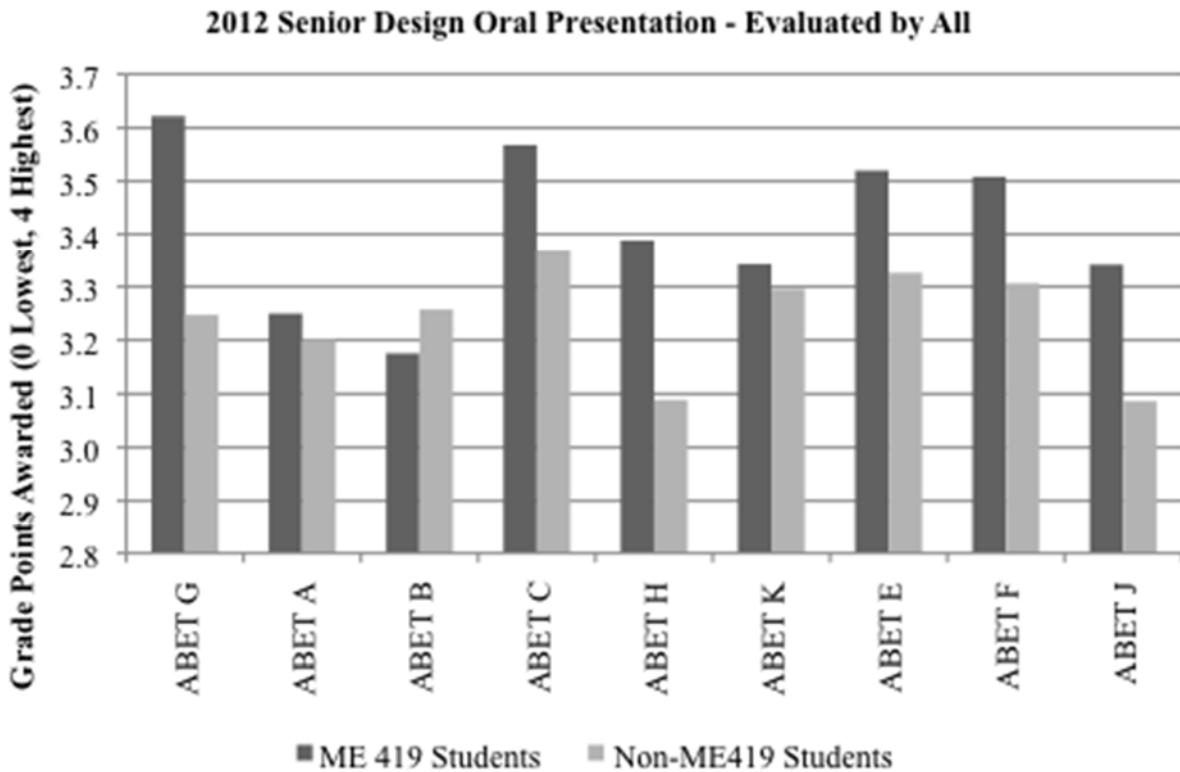

Figure 4: Average Responses from All Constituents for the 2012 Senior Design Oral Presentation Survey – ME 419 Students vs. Other Students (Non-ME 419 Students)

Table 6: Senior Design Oral Presentation Survey Questions

Question	Who were better?	
	ME 419 Students	Non-ME 419 Students
1) Describe the project objective and communicate clearly? an ability to communicate effectively (abet g)	x	
2) Apply engineering analysis? an ability to apply knowledge of mathematics, science, and engineering (abet a)	x	
3) Conduct tests and analyze data to verify engineering analysis? an ability to design and conduct experiments as well as to analyze and interpret data (abet b)		x
4) Design a system or component? an ability to design a system, component, or process to meet desired needs within realistic constraints such as economic, environmental, social, political, ethical, health and safety, manufacturability, and sustainability (abet c)	x	
5) To understand the impact of engineering in a societal context? the broad education necessary to understand the impact of engineering solutions in a global, economic, environmental, and societal context (abet h)	x	
6) Use modern engineering tools/techniques? an ability to use the techniques, skills, and modern engineering tools necessary for engineering practice (abet k)	x	
7) Function as a cohesive team? an ability to function on multidisciplinary teams (abet e)	x	
8) Display professionalism an understanding of professional and ethical responsibility (abet f)	x	
9) Knowledge of contemporary issues? knowledge of current events and societal contemporary issues (non-engineering related) (abet j)	x	

Summary

Most students enjoyed the active learning format for ME 419, an upper division mechanical engineering technical elective on computer-aided mechanical engineering, based on their positive feedback collected in surveys. Results for CE 380 are still being collected and analyzed, as a work-in-progress (WIP). By working in teams to solve engineering problems, writing reports and a reference manual, teaching each other MATLAB and Microsoft Excel, and presenting their solutions and their knowledge, these students improved their technical and professional skills by the end of the quarter. However, some students still prefer the traditional lecture format, which may be a better fit for their learning styles.

Months later, the ME 419 students demonstrated mastery of this knowledge and skills in their senior design oral presentation. Based on responses from surveys filled out by students, faculty, alumni, industrial representatives (recruiters, potential employers, etc.), ME 419 students did better than their peers who did not take ME 419 in the areas of communication, teamwork, and professionalism. Data for CE 380 students' performance in their capstone senior design experience is still being analyzed as a work-in-progress (WIP). The active learning activities in ME 419 helped students really learn and retain these skills.

The use of the course management system Moodle was expected to help the instructor prepare the active learning activities and facilitate grading. However, issues with using the uploading feature made it difficult for students and instructors to submit assignments and feedback. Despite these issues, most students still liked the course and felt that they had learned a lot.

Future Work

For the ME 419 class of Winter 2010, senior design presentation surveys for 2010 and 2011 are currently being analyzed to further corroborate the findings from Winter 2012.

The civil engineering counterpart to this course, CE 380, has been taught with this format for the last two years. The results of the university-wide student opinion surveys on this course are being analyzed.

Because the civil engineering program and its capstone senior design experience differ from those in mechanical engineering, assessment tools for the CE 380 course are still being developed to gauge how effective its active learning format is on students' mastery of skills and knowledge retention.

It is hoped that the two courses will be combined into a general engineering computational methods course to replace the current required outdated introductory programming and numerical methods undergraduate courses offered in each department. Such a course will also engage students in interdisciplinary teamwork and problem-solving, professional and technical skills that are in demand in the workforce.

The reference manuals produced by students in both sections of the ME 419 course will be uploaded onto the instructor's website for students and the community to use. It is expected that future ME 419 students will continuously improve these reference manuals.

For the detailed guidelines and rubrics for the reports, presentations, and peer evaluations, please email the authors.

Bibliography

1. Prince, M., 2004, "Does Active Learning Work? A Review Of The Research," *Journal of Engineering Education*, **93** (3), pp. 223-231.
2. Lilly, K.W., 1993, "Using Active Learning To Teach Creative Thinking On The Job: A Mechanical Engineering Example," *Proceedings: Frontiers in Education - 23rd Annual Conference: Engineering Education: Renewing America's Technology*, IEEE., Washington, DC, United States. pp. 204-208.
3. Bullard, L., Felder, R., and Raubenheimer, D., 2008, "Effects Of Active Learning On Student Performance And Retention," 2008 ASEE Annual Conference and Exposition Conference Proceedings, Pittsburg, PA, USA.
4. Goff, R. M., 2002, "The Art Of Creating An Active Learning Environment," *Proceedings 2002 ASEE Annual Conference and Exposition: Vive L'ingenieur*, Montreal, Quebec, Canada, pp. 9221-9229.
5. Hall, S.R., Waitz, I., Brodeur, D.R., Soderholm, D.H., and Nasr, R., 2002, "Adoption Of Active Learning In A Lecture-Based Engineering Class," *Proceedings - 32nd Annual Frontiers in Education; Leading a Revolution in Engineering and Computer Science Education*, IEEE Education Society, IEEE Computer Society, ASEE, Boston, MA, USA, **1**, pp.T2A/9-T2A/15.
6. Kenimer, A., and Morgan, J., 2003, "Active Learning Exercises Requiring Higher-Order Thinking Skills," 2003 ASEE Annual Conference and Exposition: Staying in Tune with Engineering Education Conference Proceedings, Nashville, TN, USA, pp. 6921-6928.
7. Sert, C., 2005, "A Tutor Program For A Numerical Methods Course For Engineers," 2005 ASEE Annual Conference and Exposition: The Changing Landscape of Engineering and Technology Education in a Global World Conference Proceedings, Portland, OR, United States, pp. 14577-14585.
8. Nickels, K., 2000, "Do's And Don'ts Of Introducing Active Learning Techniques," 2000 ASEE Annual Conference and Exposition: Engineering Education Beyond the Millennium Conference Proceedings, St. Louis, MO, United States, pp. 2209-2214.
9. Demirel, Y., 2004, "Effective Teaching And Active Learning Of Engineering Courses With Workbook Strategy," 2004 ASEE Annual Conference and Exposition Engineering Education Researches New Heights Conference Proceedings, Salt Lake City, UT, United States, pp. 4371-4384.
10. Marshall, J., 2009, "Creating An Active Learning Environment," 2009 ASEE Annual Conference and Exposition Conference Proceedings, ASEE, Austin, TX, United States.
11. Linsey, J., Talley, A., Jensen, D., Wood, K., Schmidt, K., Kuhr, R., and Eways, S., 2007, "From Tootsie Rolls To Composites: Assessing A Spectrum Of Active Learning Activities In Engineering Mechanics," 114th Annual ASEE Conference and Exposition Conference Proceedings, Honolulu, HI, USA.
12. Bagchi, S., Johnson, M.C., and Chaterji, S., 2008, "Effects Of Types Of Active Learning Activity On Two Junior-Level Computer Engineering Courses," 38th ASEE/IEEE Frontiers in Education Conference FIE 2008 Proceedings, Saratoga Springs, NY, United States, pp. F2A11-F2A16.

13. Gottfried, B.S., 1997, "Teaching Computer Programming Effectively Using Active Learning," Proceedings of the 1997 ASEE Annual Conference, Milwaukee, WI, USA.
14. Hansen, S., 2008, "Extended Active Learning As A Means To Learn Syntax In Programming Languages," 2008 ASEE Annual Conference and Exposition Conference Proceedings, Pittsburg, PA, United States.
15. Holbert, K.E., and Karady, G.G., 2009, "Strategies, Challenges And Prospects For Active Learning In The Computer-Based Classroom," IEEE Transactions on Education, **52** (1), pp. 31-38.
16. Carter, P., 2009, "An Experiment With Online Instruction And Active Learning In An Introductory Computing Course For Engineers: Jitt Meets CS1," WCCCE 2009 - Proceedings of the 14th Western Canadian Conference on Computing Education, Association for Computing Machinery, pp.103-108.
17. Furse, C., 2011, "Lecture-Free Engineering Education," IEEE Antennas and Propagation Magazine, **53** (5), pp.176-179.
18. Enszer, J.A., Goodrich, V.E., and Getman, R.B., 2012, "Improvements In Computational Methods Courses In Chemical Engineering," 119th ASEE Annual Conference and Exposition Conference Proceedings, San Antonio, TX, USA.
19. Pai, B.K., 2012, "Using Online Quizzes And Discussion Forums To Enhance Learning Numerical Methods," 119th ASEE Annual Conference and Exposition Conference Proceedings, San Antonio, TX, USA.
20. Carvalho, I.S., 2006, "Promoting Active Learning In Mechanical Engineering," Proceedings of 2006 ASME International Mechanical Engineering Congress and Exposition, IMECE2006 - Mechanical Engineering Education, Chicago, IL, United States.
21. Lacuesta, R., Palacios, G., and Fernandez, L., 2009, "Active learning through problem based learning methodology in engineering education," Proceedings 39th Annual Frontiers in Education Conference: Imagining and Engineering Future CSET Education, FIE 2009, IEEE, San Antonio, TX, United States.
22. Jagannathan, G., and Scherer, W.T., 1996, "Integration Of Cases Into The Engineering Curriculum," Proceedings of the 1996 27th Annual Meeting of the Decision Sciences Institute. Part 1 (of 3), Decision Sciences Institute, Atlanta, GA, USA, **1**.
23. Barroso, L., 2010, "Active Learning Strategies To Enhance Learning In A Civil Engineering Graduate Vibrations Course," 2010 ASEE Annual Conference and Exposition Conference Proceedings, Louisville, KY, United States.
24. Sulaiman, F., and Herman, S.H., 2010, "Enhancing Active Learning Through Groupwork Activities In Engineering Tutorials," 2010 2nd International Congress on Engineering Education: Transforming Engineering Education to Produce Quality Engineers, ICEED2010 Proceedings, IEEE Computer Society, Kuala Lumpur, Malaysia, pp. 106-109.
25. Yokomoto, C.F., and Ware, R., 1998, "Using Small Groups To Promote Active Learning And Student Satisfaction In A Required Engineering Ethics Course," Proceedings of the 1998 Annual ASEE Conference, Seattle, WA, USA.
26. Smith, K.A., 1989, "Craft Of Teaching Cooperative Learning: An Active Learning Strategy," Proceedings - 1989 Frontiers in Education Conference, IEEE Education Soc; ASEE Educational Research Methods Div, Binghamton, NY, USA, pp. 188-193.

27. Van Hattum-Janssen, N. and Loureno, J.M., 2008, "Peer And Self-Assessment For First-Year Students As A Tool To Improve Learning," *Journal of Professional Issues in Engineering Education and Practice*, **134** (4), pp. 346-352.
28. Olwi, I., 2006, "An Active Learning Fluid Mechanics Course Based On Outcomes Assessment," 113th Annual ASEE Conference and Exposition 2006 Conference Proceedings, Chicago, IL, United States.
29. Martinazzi, R. and Samples, J., 1997, "Using Active Learning To Teach Technical And Non-Technical Skills In The Same Course," Proceedings of the 1997 27th Annual Conference on Frontiers in Education. Part 1 (of 3), Pittsburgh, PA, USA, IEEE, **1**, pp. 211-213.
30. Larkin, T. and Budny, D., 2008, "Student Writing: An Active Learning Tool In Physics And Engineering Education," 2008 ASEE Annual Conference and Exposition Conference Proceedings, Pittsburg, PA, USA.
31. Larkin, T. and Budny, D., 2005, "Writing As An Active Learning Tool," ITHET 2005: 6th International Conference on Information Technology Based Higher Education and Training, Proceedings - Thirteenth International Symposium on Temporal Representation and Reasoning TIME 2006, Institute of Electrical and Electronics Engineers Computer Society, Juan Dolio, Dominican Republic, pp. S2A-22-S2A-23.
32. High, K. and Maase, E., 2007, "Active Problem-Solving In A Graduate Course On Modeling And Numerical Methods," 114th Annual ASEE Conference and Exposition Conference, Honolulu, HI, USA.
33. Cadwell, K., Zenner, G., Chesler, N., and Crone, W., 2009, "Teaching Undergraduate Engineering Students Auxiliary Design Skills Via Online Video Modules And Active Learning Exercises," 2009 ASEE Annual Conference and Exposition Conference Proceedings, Austin, TX, USA.
34. Girgis, M.M., 2011, "An Active Learning Environment For Enriching Mathematical, Conceptual And Problem-Solving Competencies," 118th ASEE Annual Conference and Exposition Conference Proceedings, Vancouver, BC, Canada.
35. Goldberg, J.R., 2012, "Active Learning In Capstone Design Courses," *IEEE Pulse*, **3** (3), pp. 54-55+57.
36. Hamade, R.F. and Ghaddar, N., 2008, "Active-Learning, Collaborative, And Problem-Based Design Engineering Course Series At The American University Of Beirut," Proceedings of the ASME 2008 International Design Engineering Technical Conferences and Computers and Information in Engineering Conference, IDETC/CIE2008 Volume 5: 13th Design for Manufacturability and the Lifecycle Conference; 5th Symposium on International Design and Design Education; 10th International Conference on Advanced Vehicle and Tire Technologies, Brooklyn, NY, USA, pp. 445-451.
37. Roemer, R.; Mascaro, D.J., Pardyjak, E.R., and Bamberg, S.J.M., 2011, "A SPIRAL Learning Curriculum For Second Year Students In Mechanical Engineering," 118th ASEE Annual Conference and Exposition Conference Proceedings, Vancouver, BC, Canada.

PolyFS: An Extensible, Underspecified, Pedagogical File System and Disk Emulator

Foadad Khosmood and Phillip Nico
California Polytechnic State University
foaad@calpoly.edu / pnico@calpoly.edu

Abstract

In recent years, teaching file systems at the undergraduate level has become increasingly challenging. File systems, while essential to most computer systems, are almost never offered as an exclusive required course for a computer science curriculum. The topic is usually taught as part of a course on operating systems (OS), along with other introductory topics such as process management, scheduling, concurrency, deadlocks, distributed processing and multiprocessing. Introductory OS courses are typically required in computer science programs but the subject matter has grown tremendously in depth and case studies, making it difficult to spend any significant time on any individual topic. In this environment, professors can barely afford to cover the basics, let alone in-depth implementation of OS issues.

PolyFS is proposed as a solution to provide class assignments meant to exercise many of the established OS principles, while offering some level of design and implementation experience to students. Specifically, we stress three advantages for using PolyFS in an instructional setting: Variety, scalability and modularity.

We are developing PolyFS, a polymorphic file system assignment and corresponding storage device emulator compatible with a variety of operating systems. PolyFS specification includes a very basic block-device emulator making it easy to use regular Unix files, or even web-based services, as emulated disks. The file system itself is intentionally under-specified to allow instructors to focus on particular aspect of file systems in their assignments and students to actually design and implement important sub-systems using algorithms covered during lecture.

Introduction and motivation

Introductory OS courses are challenging to teach partially due to the proliferation of operating system products, interfaces, and standards. To gain a good mastery of the concepts, most laboratory-based courses must involve significant low-level programming. Although there are exceptions such as DLXOS¹ where students implement an entire operating system, most concentrate on a few important subsystems out of necessity. There may be enough time in one term to cover all theory and concepts, but not enough to have programming assignments for each of them. Instructors could therefore be more efficient if they can find assignments that exercise a wide variety of OS concepts.

We believe file system implementation offers a good balance between a project that can realistically be done in a fraction of a college term, but also involve a wide variety of OS concepts and algorithms. Common file system principles overlap with those of OS and even broader computing systems³. Of the five major topics in OS courses (Processes, Scheduling, Memory management, Synchronization and I/O systems) all are present to some degree in file system implementation. Two popular undergraduate textbooks, *Tanenbaum & Woodhull*⁴ and *Silberschatz, et al.*⁵, each dedicate several chapters to file systems. Recent OS courses at Stanford University⁶ and University of California Berkeley⁷, dedicate, two weeks and one week to file systems respectively.

Perhaps the most influential teaching-oriented file system is the MINIX file system⁴, developed by Andrew Tanenbaum for educational purposes. It was adopted for early versions of Linux before the Extended file system became the Linux standard.

Exercising the students' skills is not the only thing a good assignment can do, however. A good assignment provides opportunities to assess achievement of student learning outcomes, and repeat offerings of the same assignment can form a basis for comparing the accomplishments of different cohorts of students. Genci² reports on experiences using a FAT file system assignment to assess student achievement.

In addition to the benefits of repeated use above, there is another, often unstated, benefit to assignment re-use: developing a good assignment is a lot of work. On the other hand, we have observed the phenomenon that over time assignments go stale and lose their assessment value; as more of the student population has done a particular assignment, that assignment becomes more a measure of population achievement than individual accomplishment^a.

We are developing PolyFS as a meta-specification for implementing many similar file systems that exercise the students' skills with respect to major OS topics.

Specifically as an assignment generation system, PolyFS offers variety, scalability, and modularity.

We define variety as the degree of change the assignment can undergo from term to term. We believe, much like midterms and finals, the same exact projects shouldn't be offered every term where they will be inevitably well known in the student community and may become somewhat routine for the instructors. At the same time developing new course material every term is not realistic. But if we can produce a set of reasonably divergent variations of the same assignment, perhaps we can mitigate some of the undesirable affects of repetition in assignments.

By "scalability", we refer to the scope of the deliverables. It's possible to have almost an entire file system already created with only a few minor features left to be implemented by students. This may be suitable for a lab or a small assignment. If the instructor chooses to, however, he or she can offer a much bigger project involving design of major components such as the

1 a Indeed, in Genci's report², it was found that 90% of the submitted programs had been plagiarized to some degree.

superblock or the entire file system API. This was the approach taken with TinyFS (Appendix A).

Lastly, modularity is an important feature that offers variation targeted by functionality. For example, an instructor may wish to concentrate on directory support, disk access modeling or caching subsystems. Offering a modular approach means specific features can be exercised and tested for without having to build the support architecture for them.

Modularity also addresses the tension between the assessment value of repeated assignments and the reality of assignments shelf-lives. It is possible for an instructor to maintain certain modules from term to term while changing others. By doing this, he or she can create a different assignment---a new variant of the file system---each time the course is offered, changing enough components to keep it fresh while maintaining enough components to allow for comparison from term to term.

History

PolyFS is to a large extent a more generalized form of an existing assignment called TinyFS (see Appendix A). TinyFS was created to meet some of the same goals as PolyFS and has been offered for 3 terms already with small improvements made after each term. In general students appreciate being given an opportunity to design aspects of the file system themselves. Creating one's own free block allocation system, or superblock format requires significant understanding of file system principles. Many students have anecdotally cited this assignment as something they discussed during interviews.

While TinyFS offers some design opportunities, its overall structure is fairly static with only specified "gaps" to be filled by students. TinyFS is therefore limited in offering variety and scalability. A comparison of TinyFS and PolyFS is presented below.

PolyFS and disk emulator overview

At the architecture level, shown in Figure 1, PolyFS is a system that can describe a specific file system variant (*PolyFS-n*) which in turn uses an emulator or is installed on the host file system.

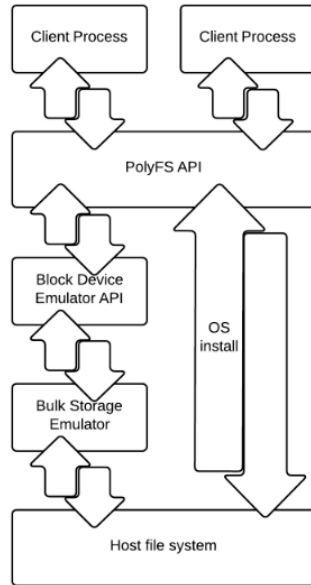

Figure 1. PolyFS high level architecture

One or more client programs link to the PolyFS library and interact with the file system using its published API. A header file specifying the PolyFS-*n* details such as the block formatting and API allows both clients and test programs to read and write to the disk. This means that almost all the functionality of *PolyFS-n* can be tested by writing different client processes. A “black box” testing approach uses the API to interact with the system and assess its features and performance.

Separate tests can also be generated based on current state of the emulated disk. Figure 2 shows a typical block file system storage space allocation. While the status of blocks remains hidden from the client programs by design, testing can be done directly on the emulated disk device to check for consistency and efficiency of use.

Super Block	inode Block	file extent
file extent	Free Block	Free Block
Free Block	file extent	inode Block
file extent	Free Block	Free Block
Free Block	Free Block	Free Block

Figure 2. Example block allocation

PolyFS specification and API

PolyFS was conceived with the goals of making it easier to teach OS concepts. It is purposefully underspecified to allow for filling in of gaps by the instructor or students in a design exercise. The final outcome of the exercise, however, depends on a full specification (we call PolyFS-n) and implementation.

In general two categories of specification details can be varied: emulator and PolyFS. Emulator is used to interact with a target device. Thus only block level operations should be specified. The basic API is given in four functions –openDisk(), readBlock(), writeBlock(), and closeDisk()– which will be used by students as a foundation on which to implement the PolyFS interface.

Table 1 is a list of basic PolyFS features, the bare minimum that we consider necessary for an assignment. Using these features a very basic single-directory block file system can be created with both read and write operations and tested. We recommend instructors begin with this and then move into advanced features or alternatively pick and choose which of the advanced features each team should implement.

Advanced features

Building on the basic features, the instructors now have the opportunity to expand the assignment in one or more directions as desired. Several of the advanced features are shown in Table 2, but more are possible. We elaborate on selected advanced features.

Byte-level updates: To make the problem somewhat more tractable, we specify pfs_writeFile() to accept the entire file to be written, in form of a terminated character buffer. A student can design this function by first calculating the number of blocks necessary to store the buffer, then to create the inode block and file extents. No file pointer implementation is necessary. An advanced feature, pfs_writeByte() is capable of writing just one byte to the location indicated by the file pointer.

Disk status and defragmentation: Fragmentation is a factor in many storage systems. To familiarize the student with fragmentation issues, we extend PolyFS to include functions pfs_fragStatus() and pfs_defrag().

Directory support: Small toy file systems can be implemented with no directory support. That's the case with the base PolyFS. However, directory support including two level or tree-based directory structures can be supported through the advanced feature.

File locks: File-level synchronization support can be added in form of a pair of lock/unlock functions. Implementation of synchronization algorithms is left up to the students as an exercise.

Table 1. PolyFS basic features

category	Feature / API	specification status	notes
emulator	using emulator or direct OS installation?	instructor decides this	if emulator, specify Unix file(s) to use as emulated disk
emulator	using storage driver or emulating disk operations?	instructor decides this	
storage emulator	basic device interface	Student design exercise	additional ioctl() function call to be called inside disk emulator functions
emulator	openDisk(), readBlock(), writeBlock(), closeDisk()	specified by instructor for target block device, or use default for Unix files	Instructor may choose to forego using an emulator, and require installation of PolyFS on the target OS
emulator	formatDisk(), sync()	specified by instructor or students	formatDisk() requires access to PolyFS general block spec.
PolyFS	general block size (default: 256 bytes) and format	specified by PolyFS / modifiable by instructor	magic number, in particular could be set by the instructor each term
PolyFS	inode block spec.	student design exercise	
PolyFS	file extent block spec.	student design exercise	
PolyFS	file block allocation	student design exercise	algorithm to recover all blocks of a file
PolyFS	free block allocation	student design exercise	algorithm to manage free blocks
PolyFS	superblock spec.	student design exercise	
PolyFS	directory inodes	student design exercise	
PolyFS	symbolic links	student design exercise	
PolyFS	consistency checks and defragmentation	student design exercise	
PolyFS	file naming convention	specified by PolyFS, modifiable by instructor	could be altered with directory support
PolyFS	basic API	specified by PolyFS	extensible by instructor
PolyFS	pfs_openFile(), pfs_renameFile()	student design exercise	returns a file descriptor
PolyFS	pfs_writeFile()	student design exercise	writes an entire terminated buffer as single PolyFS file to disk
PolyFS	pfs_readByte()	student design exercise	reads one byte from a pfs file at the file pointer location
PolyFS	pfs_seek()	student design exercise	moves the file pointer
PolyFS	pfs_closeFile()	student design exercise	closes file and de-allocates memory resident resources
PolyFS	pfs_deleteFile()	student design exercise	deletes file from disk

Disk scheduling: Storage devices are covered in most OS courses. We have designed PolyFS with a separate module dedicated to storage systems. Rotating media physical subsystems, for example, can be modeled inside the module allowing students to implement disk scheduling algorithm covered in lecture.

Assignment

A typical PolyFS assignment will consist of providing all the instructor-specified information, as well as a number of features to be implemented. The basic deliverable source files are the emulator library, PolyFS library and a demo program that shows the instructor the functionalities implemented. The instructors will have multiple test client programs of their own that can be linked to the relevant libraries and make use of the system. Figure 3 shows a sample Makefile for a Unix based PolyFS assignment.

Assignment evaluation

We recognize that evaluation of assignments is a significant part of the teaching effort. Any assignment that is unusually difficult to evaluate for classes ranging from 20 to 200 in size would probably not be adopted by educators. We have had evaluation in mind when designing PolyFS. Automated test case evaluation has two distinct benefits. First, it eases the burden on the educator, allowing more focus on code reading, style and performance assessment. Second, it can provide a level of self-assessment to the student. Making some of the elementary test cases public, with a public and reliable evaluation system will result in higher quality assignment submissions.

In the case of PolyFS, the nature of the interface greatly helps in automated evaluation. Using a test program accessing the disk through the established API in the assignment allows for the instructor scripts to easily verify many of the basic functions: reading and writing to blocks, superblock structure, file operations, time stamps and access rights can easily be tested within a single instructor test program.

Two test programs can be used within a script to evaluate file locks and concurrency features.

Table 2. Advanced Features

feature	additional API	notes
storage crypto emulator	<i>store_encrypt()</i> , <i>store_decrypt()</i>	encryption algorithm needed
storage compression emulator	<i>store_compress()</i> , <i>store_decompress()</i>	compression algorithm needed
byte-level update	<i>pfs_writeByte()</i> writes one byte to the current offset of an open file	basic API only supports <i>pfs_writeFile()</i> where the entire file content must be passed in buffer
support file creation time and modification time	<i>pfs_readFileInfo()</i> returns an array of two time stamps	involves modifying open() and writeFile() API calls
disk status check and defragmentation	<i>pfs_fragStatus()</i> <i>pfs_defrag()</i> moves blocks to place all free blocks together at the last portion of the disk	returns a char vector for block fragmentation status, plus an additional char with an overall status
directory support	<i>pfs_makeDir()</i> <i>pfs_deleteDir()</i> <i>pfs_copy()</i> works on both directories and files <i>pfs_listDir()</i> returns information for all files in the directory	create and delete directories. Open() API all will have to change to accommodate a longer string being passed in, rename() can be modified to achieve a “move” from one directory to another
file locks	<i>pfs_lock()</i> , <i>pfs_unlock()</i>	allows synchronization at file level, testable with multiple client programs
access rights, and mode	<i>pfs_chmod()</i> , <i>pfs_chown()</i>	support read-only, write-only, and basic user-level ownership, access-rights scheme to be specified in header files
block rotation	<i>pfs_engageBlockRotation()</i>	supports rotation of blocks to simulate all parts of the device being equally affected by degradation, used in sold-state disk technology
disk scheduling	<i>pfs_applyDiskScheduling()</i>	simulates rotating media buffer/cache systems and sector-level updating
visualization		Write a separate process to periodically read the PolyFS disk and provide a graphical live representation of each block which can be shown to an observer as an application or web page while testing is in progress.

```

CC = gcc
FLAGS = -Wall -g
PROG = PolyFsDemo
OBJS = PolyFsDemo.o libPolyFS.o libDisk.o

$(PROG): $(OBJS)
$(CC) $(CFLAGS) -o $(PROG) $(OBJS)

PolyFsDemo.o: PolyFsDemo.c libPolyFS.h
$(CC) $(CFLAGS) -c -o $@ $<

libPolyFS.o: libPolyFS.c libPolyFS.h libDisk.h libDisk.o
$(CC) $(CFLAGS) -c -o $@ $<

libDisk.o: libDisk.c libDisk.h
$(CC) $(CFLAGS) -c -o $@ $<

```

Figure 3. Sample Makefile for a PolyFS assignment

Table 3 gives a brief explanation of all the source files involved.

Table 3. Example assignment deliverable source files

source file	supplied by	notes
libDisk.h	instructor	provides emulator API, and disk information
libDisk.c	student	implementation of the block device emulator
libPolyFS.h	instructor / student	PolyFS API functions, PolyFS block format specifications
libPolyFS.c	student	implementation of PolyFS API
PolyFSDemo.c	student	a client program interacting with a PolyFS disk

Pedagogical experience

A precursor to PolyFS called TinyFS has been already implemented and used for three terms as the final assignment in OS courses of the California Polytechnic State University. TinyFS features 256 byte blocks only. Student feedback indicates that the design opportunity is much appreciated. Students report that they find themselves reviewing textbook chapters on block allocation and superblock functionality in order to design an efficient file system.

Work in progress

We are currently working to support an automated PolyFS spec generator based on instructor input. Such a generator could produce a *PolyFS-n* where n is a unique identifier reflecting assignment choices made by the instructor. Producing these unique specs would allow for automated testing tools to be developed as well. The theory is that unit-level testing routines for particular features could be automatically combined based on the particular specification.

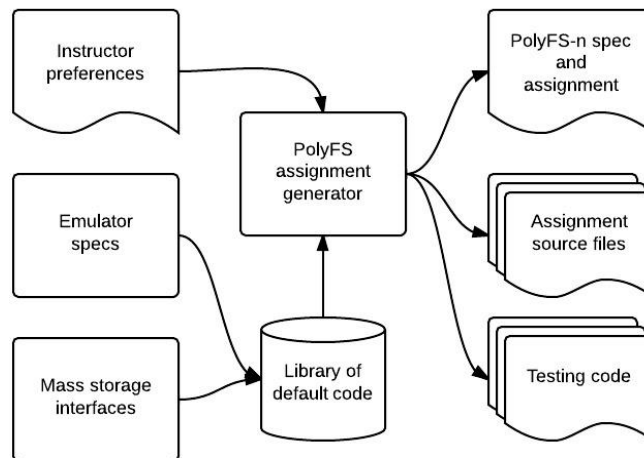

Figure 4. PolyFS assignment generator

Student feedback

Our development of PolyFS takes into account our experience from TinyFS, including student feedback. For Winter term 2013, we surveyed one class that was given TinyFS as its final assignment, representing one out of 4 large programming assignments, and 10% of total grade in the operating systems class. We asked mostly for comparisons of the TinyFS assignment against the other three assignments in that same course.

29 students responded (out of 33). The majority of the students are seniors in their last four quarters of the B.S. program in Computer Science, Computer Engineering or Software Engineering at California Polytechnic State University.

We find that in general, students support and are open to design based assignments and prefer more of them. They feel that this particular assignment taught them much about file systems. They feel that, for the TinyFS assignments, concepts are relatively easy, but testing is the most difficult aspect. They also value group work highly for this assignment.

The students were also asked to respond in paragraph form to the question “What was the most difficult aspect of this assignment for you?” 29 students participated.

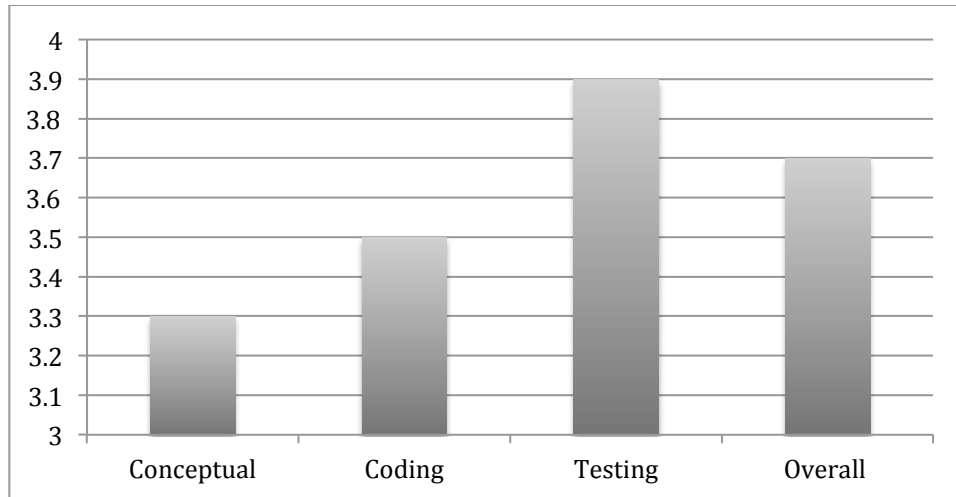

Figure 5. Student self-reported assignment difficulty (1-5 where 5 is "very difficult").

Although a few miscellaneous responses pointing to difficulty of working with partners and not being familiar enough with the C programming language were mentioned, the majority of the respondents cited the spec as having been vague forcing the students to have to come up with their own design and further failure scenarios. Some of the more interesting responses in this category are:

- Visualizing the system as a whole.
- The spec is very open ended so it is very difficult to figure out the best way to implement something.
- Testing has definitely been the most difficult aspect of this project, as there are many edge cases to account for. I also feel unsure of what will be tested, which makes the process more frustrating. Maybe a test driver would make the process less stressful.
- The most difficult aspect of the assignment for me was keeping track of all of the bits in the bit vector. I was not the most familiar with bit operations and so I learned a lot along the way.
- I think the hardest part of the assignment is figuring out how to implement things since it is a design assignment. There is a lot of freedom to implement ideas in different ways, so careful thought and planning must be used to avoid problems arising. A big point in this is planning ahead for the extra features, which can alter the layout of an inode block and add in more complication to the functionality.
- The most difficult aspect of the assignment was wrapping my head around what I was supposed to do. It took a long time to create the correct picture of how everything fit together. I also had a hard time distinguishing a file descriptor for a regular file and a file descriptor for the disk.

Responses to other quantitative questions on the survey are illustrated in Figure 6.

Lastly, two “Yes/No” questions were included: “Would you prefer more design?” and “Was group work important in this assignment?” The responses to both, shown in Figure 7, were overwhelmingly “Yes”.

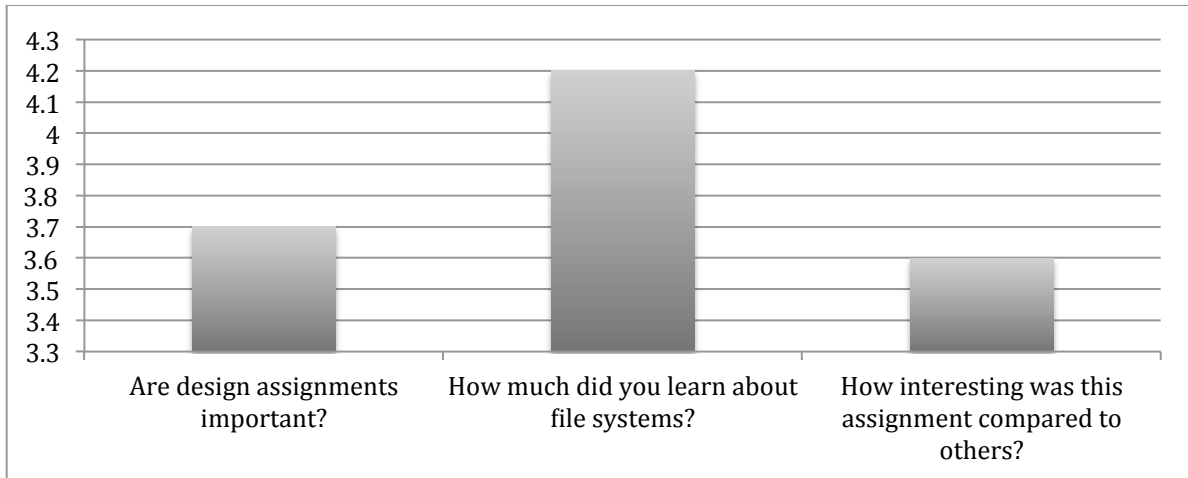

Figure 6. Quantitative student feedback (1-5 scale).

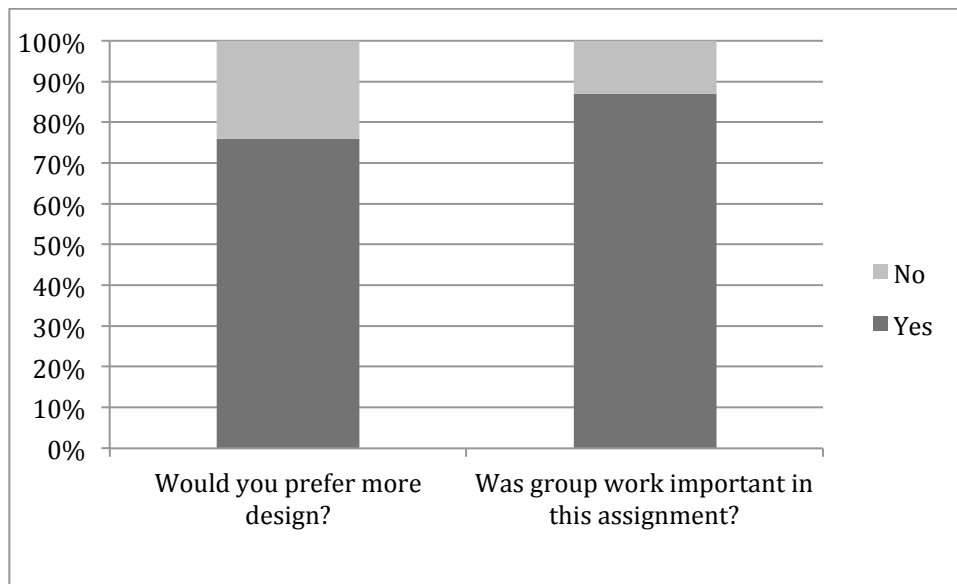

Figure 7. Yes/No questions on student survey.

Conclusion

PolyFS is a file system standard capable of generating individual course assignments to test particular areas of focus for file system education. PolyFS is a work in progress, drawing from the lessons and feedback of TinyFS. We are encouraged that design and group work are valued by students, and that the general approach leads to substantial retention of information in comparison to straight implementation assignment or lecture material on file systems. In the coming terms, we will implement more and more of the overall system and use the results in real OS classes as we have been doing with the precursor, TinyFS.

Evaluation work-load can be reduced by using the same API to test PolyFS functionality. Work continues toward a suite of tools integrating specification generation with test-case generation for a particular PolyFS-n variant.

Appendix A. TinyFS Assignment

This is the existing TinyFS assignment from CPE 453 Operating Systems course, California Polytechnic State University, Winter 2013.

Program 4 | CPE 453 | Professor Foaad Khosmood
This assignment can be done in groups of up to 3.

TinyFS file system and disk emulator

For this assignment, you'll be implementing the TinyFS file system and emulating it on a single Unix file.

Objective

The goal for this assignment is to gain experience with the fundamental operations of a file system. File systems are not only themselves an integral part of every operating system, but they incorporate aspects of fault tolerance, scheduling, resource management and concurrency.

Phase I: disk emulator

The first part of the assignment is to build a disk emulator. At the lowest level of operation, an input/output control (ioctl) system call interacts directly with the device to accomplish an operation requested by the user. For disk drives (called block devices) this is usually just reading or writing a block. We will implement an emulator that will accomplish basic block operations on a regular Unix file.

The emulator is just a library of functions that interacts with a file. Three functions are necessary: `openDisk()`, `readBlock()` and `writeBlock()`. There are a couple of pieces of static data that are required. These can be `#defined` in header files. Two important ones are: block size (`blockSize`) in bytes, and default name of the disk file (`diskName`), which should be set to "TinyFSDisk".

```
/* this functions opens a regular Unix file and designates the first nBytes of it as
space for the TinyFS Disk. If nBytes > 0 and there is already a file by that name,
that file's content will be overwritten. There is no requirement to maintain integrity
of any file content beyond nBytes. That means, you can always open a new file and
write nBytes to it. To open an existing disk (assuming the filename is valid), call
openDisk() with nBytes = 0. The return value is -1 on failure or a disk# on success.
*/
int openDisk(char *filename, int nBytes);

/* readBlock() reads an entire block of blockSize size from the open disk (identified
by the disk#) and copies the result into a local buffer (must be at least of
blockSize). The bNum is a block number, which must be translated into a byte offset to
be seek()ed in the Unix file. That translation is simple: bNum=0 is the very first
byte of the file. bNum=1 is blockSize offset from the beginning of the file. bNum=X is
X*blockSize bytes into the file. On success, it returns 0. -1 or smaller is returned
if Disk is not available (hasn't been opened) or any other failures. You may define
your own error code system. */
int readBlock(int disk, int bNum, void *block);
```

```

/* writeBlock() takes a disk# and a block number and writes the content of the
argument block to that location. Just as readBlock(), it must seek() to the correct
position in the file and then write to it. On success, it returns 0. -1 or smaller is
returned if Disk is not available (hasn't been opened) or any other failures. You may
define your own error code system. */
int writeBlock(int disk, int bNum, void *block);

```

Phase II: TinyFS file system implementation

TinyFS is a very simple file system. In fact it is under-specified to give you the freedom to implement it using many algorithms that you learned about. There are no directories or mount points, which means all the files are under a single directory. The disk blocks of TinyFS can be any of these types:

Block name	Block code	Description	number possible	size (bytes)
Superblock	1	contains the magic number, free-list implementation and other info	1	256
inode	2	contains name of the file, file block list implementation	many	256
file extents	3	contains block# of the inode block	many	256
free	4	is ready for future writes	many	256

Block format

These bytes are defined. The rest are up to you to implement however you see fit. For example to keep track of the free blocks, you may want to use a bit vector or a forwarding link on the superblock. Same with file name information for an inode.

Byte	first byte offset	second byte offset
0	[block type = 1,2,3,4]	0x45
2	[address of another block]	[empty]
4	[data]	...
6

Block Types

Super Block

The Super Block stores meta-information about the file system and is always block 0. The block contains three different pieces of information. First, it provides a mechanism to detect when the disk is not of the correct format. Second, it contains the block number of the root inode (for directory-based file systems). Third, it handles the list of free blocks. This can be done by having a link to the first free block in a chain of free blocks, or implementing a bit vector and storing the vector right there in the super block.

The mechanism the Super Block uses to detect a disk that isn't formatted properly is the magic number mechanism. That means a number not likely to be found in a block by accident. For us that number will be 0x45 and it is to be found exactly on the second byte of every block.

inode

The inode block keeps tracks of meta-data for the file object. Typically ownership (user, group), file type, creation time, access time, etc. are included. For TinyFS only the name is required. The name can be just 8 alphanumeric characters and no more. Examples: "file1234", "khosmoody" or "my2ndLog".

For inode blocks, you have to design where and how to store the file meta-data like the file name and/or time stamps and ownership. You also have to pick an offset (for example 32 bytes) at which the actual data part of the file starts.

file extent

A file extent block contains file content data. It may be just a part of the content in which case it should contain a link to the next block of the same file content. It may contain the last of the file content (file ending) in which case, the rest of the bytes should be zero'ed out and the link byte should also be set to 0.

free block

Free blocks are empty and available to be written to. But just as any other block, they have to have the required bytes 0,1 and 2. You may choose to use the link (byte #2) to form a chain of free blocks, otherwise you can set it to 0.

TinyFS interface functions:

Only 6 API functions are needed to implement the TinyFS interface.

```
/* Opens a file for reading or writing. Create a dynamic resource table entry for the
file, and returns a file descriptor (integer) that can be used to reference this file
from now on. */
fileDescriptor tfs_openFile(char *name);

/* Closes the file, de-allocates all system/disk resources, and removes table entry */
int tfs_closeFile(fileDescriptor FD);

/* writes an entire buffer, representing the entire file content, to a file. Sets the
file pointer to 0 (the very beginning) when done. Returns success/error codes.
(content terminated by null "\0") */
int tfs_writeFile(fileDescriptor FD, char *buffer);

/* deletes a file and marks its blocks available on disk. */
int tfs_deleteFile(fileDescriptor FD);

/* reads one byte from the file and copies it to buffer, uses the current file pointer
location, and increments it by one after. If the file pointer is already at the end of
the file (where the terminating NULL character is) then tfs_readByte() should return
an error (- value) and not increment the file pointer. */
int tfs_readByte(fileDescriptor FD, char *buffer);

/* change the file pointer location to offset (absolute) */
int tfs_seek(fileDescriptor FD, int offset);
```

Assignment

- Implement the 6 interface functions above (80%)
- Add two additional areas of functionality from the list (a-d) below. You are free to implement them any way you wish with any number of parameters / return type. (20%)
 - a Fragmentation info and defragmentation
 - implement tfs_displayFragments() /* this function allows the user to see a map of all blocks with the non-free blocks clearly designated. You can return this as a linked list or a bit map which you can use to display the map with */

- implement `tfs_defrag()` /* moves blocks such that all free blocks are contiguous at the end of the disk. This should be verifiable with the `tfs_displayFragments()` function */
 - b Directory and renaming
 - `tfs_rename()` /* renames a file. New name should be passed in. */
 - `tfs_dir()` /* lists all the files on the disk */
 - c Read-only and writeByte support
 - implement the ability to designate a file as “read only”. By default all files are “read write” (RW).
 - `tfs_makeRO(char *name)` /* makes the file read only. If a file is RO, all `tfs_write()` and `tfs_deleteFile()` functions that try to use it fail. */
 - `tfs_makeRW(char *name)` /* makes the file read-write */
 - `tfs_writeByte(fileDescriptor FD, int offset, unsigned int data)`, a function that can write one byte to an exact position inside the file.
 - `tfs_writeByte(fileDescriptor FD, unsigned int data)` is also acceptable. (uses current file pointer instead of offset).
 - d Time stamps
 - implement creation time stamps for each file to be stored in the inode block
 - `tfs_readFileInfo(fileDescriptor FD)` /* returns the file's creation time */
- Write a demo program that includes your TinyFS interface to demonstrate the basic functionality of the 6 required functions and your chosen additional functionality. You can display informative messages to the screen for the user to see how you demonstrate these.

Deliverables

- as usual, submit a tar.gz archive via polylearn with the following:
 - all source files: .c, .cpp, .h
 - You must have at least three separate source files
 - 1 emulator file (libDisk)
 - 2 tinyFS interface file (libTinyFS). This file will access libDisk for disk emulator functionality.
 - 3 demoTfs driver file that contains a main(), and includes libTinyFS headers (but not libDisk).
 - a makefile (called Makefile) that compiles all the libraries and makes the following executable:
 - demoTfs
 - a README with:
 - Names of all partners
 - An explanation of how well your TinyFS implementation works
 - An explanation of which additional functionality areas you have chosen and how you have shown that it works.

Appendix B. A TinyFS demo program

This is a TinyFS demo program listing and a subsequent look at the emulated disk.

```
foaad@unix3:~/453/workspace $ ./demoTfs
No TinyFSDisk found, formatting...
Checking input in file abcd1234:
The quick brown fox jumped over the lazy dog

Reading after seek exepect 5:  t

Testing tfs_readFileInfo output:
File created on: Wed Jan 30 11:50:11 2013

Closed tfs_closeFile then called tfs_write, this should fail:
failed to write file

Closed tfs_closeFile then called tfs_readByte, this should fail:
failed to read

Reading input from abcd1234, file descriptor fd1, output:
some sentences some sentences some sentences some sentences

Reading after seek exepect 5:  5

Reading input from abcd1234, file descriptor fd, output:
6789

List all files in directory with tfs_dir:
new3
new2
newName

Reading input from abcd1234, file descriptor fd1:
success

Attempt to write to deleted file should fail:
it is a failure

foaad@unix3:~/453/workspace $ hexdump -C TinyFSDisk
00000000  01 45 09 00 00 00 00 00 00 00 00 00 00 00 00 00 |.E.....|
00000010  00 00 00 00 00 00 00 00 00 00 00 00 00 00 00 00 |.....|
*
00000100  02 45 00 00 66 64 33 00 6e 65 77 32 17 79 09 51 |.E..fd3.new2.y.Q|
00000110  00 00 00 00 00 00 00 00 00 00 00 00 00 00 00 00 |.....|
*
00000200  02 45 00 00 61 62 63 64 31 32 33 34 17 79 09 51 |.E..abcd1234.y.Q|
00000210  00 00 00 00 00 00 00 00 00 00 00 00 00 00 00 00 |.....|
*
00000300  04 45 07 00 00 00 00 00 00 00 00 00 00 00 00 00 |.E.....|
00000310  00 00 00 00 00 00 00 00 00 00 00 00 00 00 00 00 |.....|
*
00000400  04 45 0a 00 00 00 00 00 00 00 00 00 00 00 00 00 |.E.....|
00000410  00 00 00 00 00 00 00 00 00 00 00 00 00 00 00 00 |.....|
*
00000500  02 45 00 00 6e 65 77 33 00 6e 65 77 0d 79 09 51 |.E..new3.new.y.Q|
00000510  00 00 00 00 00 00 00 00 00 00 00 00 00 00 00 00 |.....|
*
00000600  02 45 00 00 6e 65 77 32 00 6e 65 77 0d 79 09 51 |.E..new2.new.y.Q|
00000610  00 00 00 00 00 00 00 00 00 00 00 00 00 00 00 00 |.....|
*
00000700  04 45 04 00 00 00 00 00 00 00 00 00 00 00 00 00 |.E.....|
00000710  00 00 00 00 00 00 00 00 00 00 00 00 00 00 00 00 |.....|
*
00000800  02 45 00 00 66 64 32 00 66 64 33 00 17 79 09 51 |.E..fd2.fd3..y.Q|
00000810  00 00 00 00 00 00 00 00 00 00 00 00 00 00 00 00 |.....|
*
00000900  04 45 03 00 00 00 00 00 00 00 00 00 00 00 00 00 |.E.....|
00000910  00 00 00 00 00 00 00 00 00 00 00 00 00 00 00 00 |.....|
```

Bibliography

- [1] Miller, E. L., “The DLX Operating System (DLXOS)”
<http://users.soe.ucsc.edu/~elm/Software/Dlxos/dlxos.shtml>
- [2] Genci, J. Knowledge assessment — practical example in testing. In *Technological Developments in Education and Automation*, M. Iskander, V. Kapila, and M. A. Karim, Eds. Springer Netherlands, 2010, pp. 409–412.
- [3] Holliday, M.A. "Teaching Computer Systems through Common Principles", 41st ASEE/IEEE Frontiers In Education Conference, October 2011, Rapid City, SD, pp. S2G-1 to S2G-6.
- [4] Tanenbaum, Andrew S; Albert S. Woodhull , *Operating Systems: Design and Implementation* (3rd ed.). Prentice Hall, 2006.
- [5] Silberschatz, Galvin, and Gagne, *Operating System Concepts*, 8th Edition. Wiley, 2009.
- [6] Joseph, Anthony and Stoica, Ion. Course “CS 160: Operating Systems and Systems Programming”, University of California Berkeley, Spring 2012.
<http://inst.eecs.berkeley.edu/~cs162/sp12/>
- [7] Ousterhout, John. Course “CS 140: Operating Systems”, Stanford University, Winter 2013.
<http://www.stanford.edu/~ouster/cgi-bin/cs140-winter13/>

New Technology and Design Methodology for Micromouse: Challenges and Solutions

**Ameneh Akbari, Karla Ananias, Jeffery Bouchard, Qian Wang, and George Law
Department of Electrical and Computer Engineering
California State University, Northridge, CA 91325**

Abstract

The micromouse project has been integrated in many university curricula internationally. In the project, the students design and build an autonomous robot which explores and maps a fixed size maze, and races to the center of the maze in the shortest time. These mice will compete in IEEE or other engineering society sponsored competitions every year. Normally, the students will use a microcontroller or a microprocessor with external peripheral devices to control the micromouse. As the technology advances, the microcontrollers or microprocessors have been gradually replaced with field programmable gate array devices (FPGA). Using the latest technology and design methodology in the micromouse design, however, involves new challenges for the students and their supervising faculty. This paper describes the challenges in the system-on-chip (SOC) design where a field programmable gate array device (FPGA) is programmed to control the micromouse. The FPGA is also used to implement the various interfaces and memory. The paper also describes other related challenges involving the curriculum support, the software training, the algorithm coding, the simulator, and the design/software depository on the internet. More importantly, it describes how these challenges are met and how the next micromouse groups can be better prepared.

Introduction

Each year since 1972, the micromouse competitions have been held in cities and university campuses all around the world.¹ The participants, students and engineers, design and program their micromice to autonomously find the center of a 16 by 16 cell maze within 10 minutes. After finding the center, the micromouse may map the entire maze to locate the shortest route to the center. Using the shortest route, the micromouse will attempt to reach the center in a fastest run.

The first generation of micromouse at California state university (CSUN), Northridge, was based on the Motorola 68HC11 microcontroller. After the 68HC11 microcontrollers had become obsolete and the supporting course had adopted the next generation 68HC12 microcontroller, the micromouse was designed around this microcontroller or others. Switching to other microcontrollers requires re-design and re-learning. To avoid repeated development system changes and course modification, we decide to switch to system-on-chip (SOC) design.

As the system-on-chip design is software based, one only needs to learn the software to design any system including the controller for the micromouse. In the system-on-chip design, the synthesis of the system hardware is all handled by the software and the underlining hardware is

masked from the designer. As a result, changing the Field Programmable Gate Array (FPGA) when they become obsolete will not require any re-learning of the software.

To integrate the system-on-chip design into the micromouse projects carries many challenges. While the system-on-chip course can be scheduled concurrently with the micromouse project, the courses that lead to the system on chips must be scheduled in prior semesters. Re-arranging these courses, as well as the number of courses needed to support the micromouse project, is a challenge.

CSUN Digital Senior Course Electives

Figure 1 shows the electrical engineering (EE) senior elective course flow at CSUN.² Ideally, each of the micromouse team members has completed these senior course electives prior to starting the micromouse project: ECE420 programmable logic and VHDL (*VHSIC hardware description language*), ECE422 computer architecture, ECE425/L microprocessor systems, and ECE525/L system-on-chip course. But the past experience has shown that the students were not able to complete them due to the course dependency and the clustering of these courses in the senior year. One possible solution is to move some of the courses to lower level so that the students can take them earlier. Doing so, however, triggers the lowering of other courses as well due to the pre-requisite requirements. What we can presently do is to include, in the micromouse team, one or two graduate students who have completed the respective senior electives. The graduate student will basically lead and mentor the other undergraduate students in the design of the micromouse system.

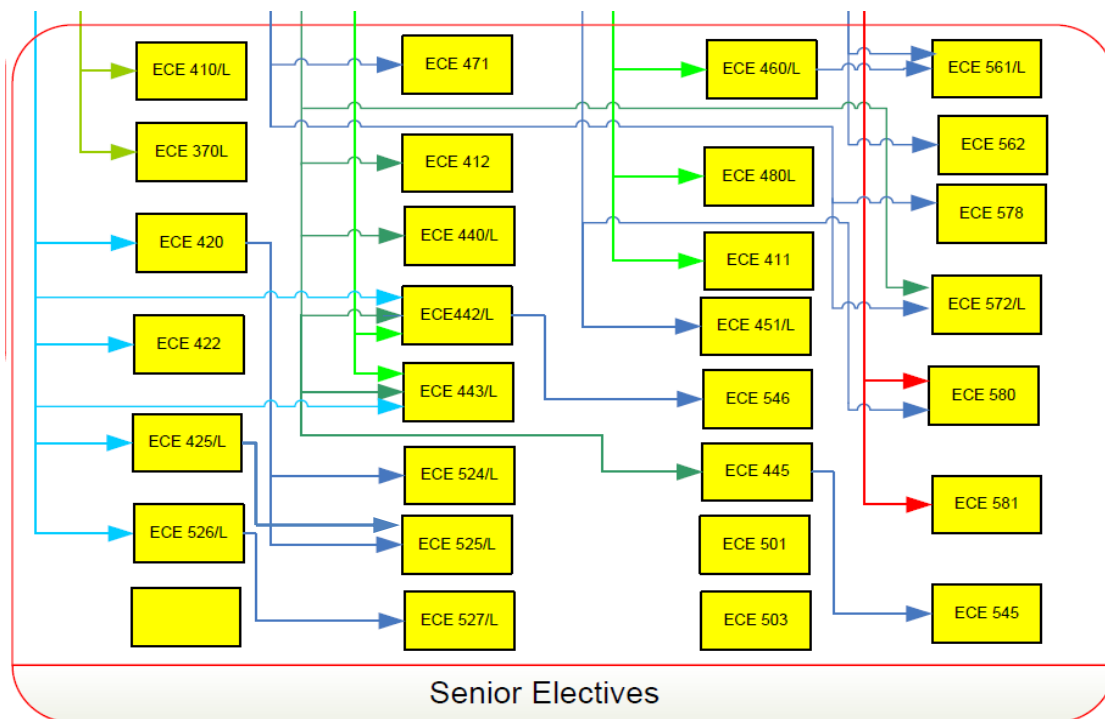

Figure 1. CSUN Electrical Engineering Senior Course Electives

Microcontroller-based versus System-on-chip Design^{3,4}

The micromouse system block diagrams in Figures 2 and 3 show that the peripheral devices and their interface for the microcontroller-based design and the system-on-chip design of the micromouse are essentially identical. They differ in how the interfaces are constructed. In the microcontroller-based design, the interfaces are built into the microcontroller whereas these interfaces are software modules, VHDL or Verilog modules, synthesized in the FPGA in the system-on-chip system. Similarly, the CPU, memory, and buses are built into the microcontroller and are software modules, VHDL or Verilog modules, synthesized in the FPGA in the system-on-chip system. Thus, the design of the CPU, memory, buses, and the peripheral interfaces in the system-on-chip system falls onto the shoulders of the micromouse team members. A constructed system-on-chip micromouse equipped with a DE-0 nano board and a liquid crystal display (LCD) is shown in Figures 4 and 5.

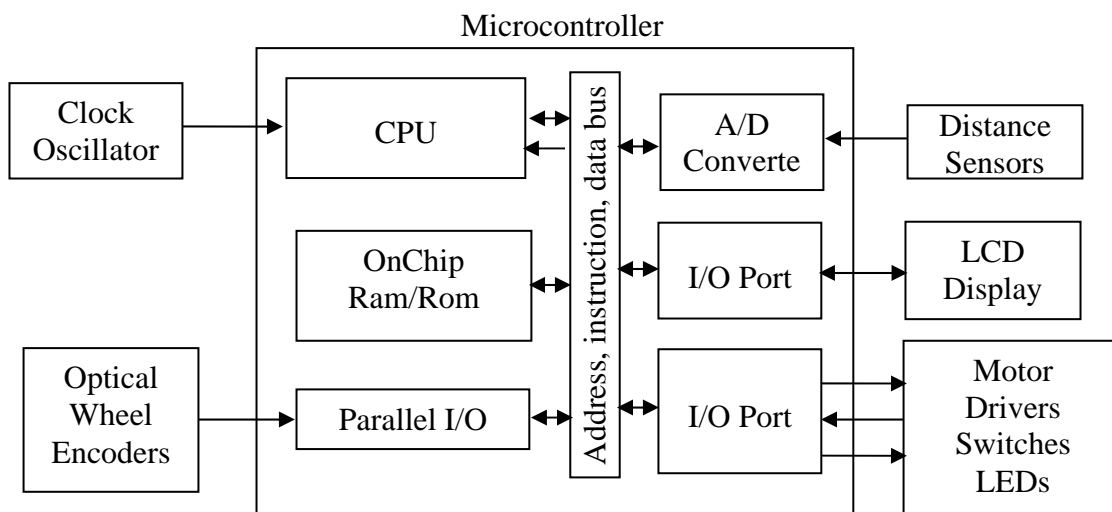

Figure 2. Microcontroller-based micromouse system

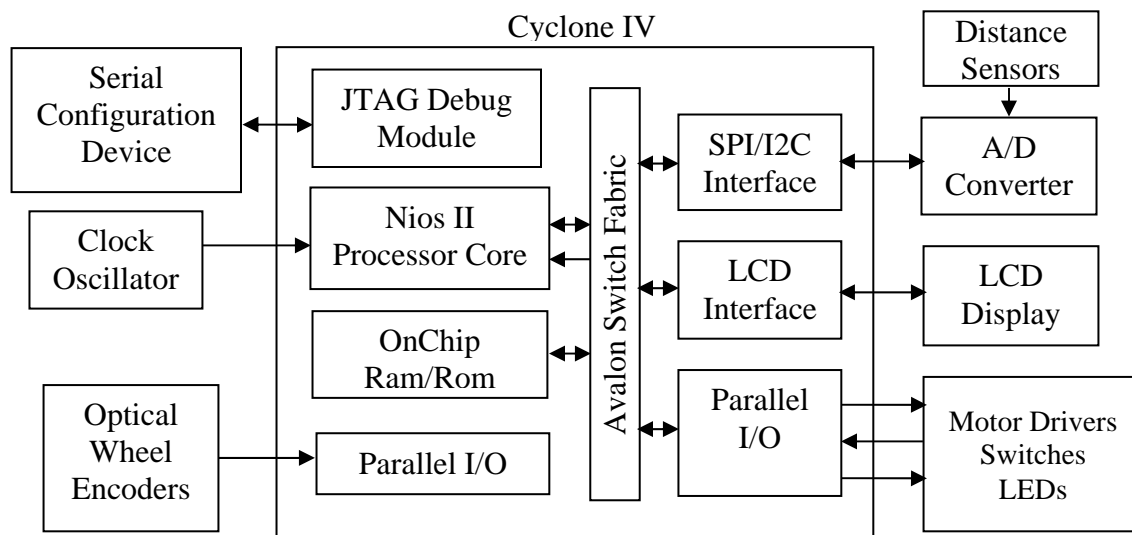

Figure 3. System-on-chip micromouse system



Figure 4. DE-0 nano-board



Figure 5. System-on-chip Micromouse

The CSUN curriculum shows that the EC525/L system-on-chip course requires the ECE420 programmable logic and VHDL course and the ECE425/L microprocessor systems course as prerequisites. As a result, we could not find any CSUN undergraduate electrical engineering student who has taken or is concurrently taking ECE525/L when the micromouse project starts in the first semester in the senior year. To fill this void, we have to include graduate students in the micromouse team. Furthermore, to ensure that the team members have the knowledge of programmable logic and VHDL in the beginning of the project, we select the students who have taken ECE420 in their junior year and preferably also are concurrently taking ECE425/L.

Software Tool

The process of designing the system-on-chip micromouse system include drawing the schematic diagram, simulation/testing, drawing the circuit layout, and making the printed circuit board. Because the micromouse projects design tasks are assigned to different team members based on personal interest and expertise, the hierarchical schematic diagram is the most practical choice. At CSUN, the Cadence/Orcad software tool to draw schematic diagrams is introduced in the sophomore courses. Because the design is simple and individually based, the students use flat schematic diagrams. When these students reach the senior year, they need to re-learn the software tool to divide their design into hierarchical levels. The micromouse team spent many weeks in learning to do so.

The students have more trouble in using the software tools to draw the circuit layout; they have not been taught to do so in any courses. The micromouse team spent their winter break in learning to draw the circuit layout for the micromouse printed circuit board.

The observation of the micromouse team in using the software tool to draw the schematic diagram and the circuit layout have lead us to believe that the complete process of designing a circuit system must be introduced as late as junior year. The process must emphasize on team work, the design must be hierarchical, and the process must end with a working printed circuit board.

Modified Flood Fill Algorithm and Maze-Solver Simulator

Many maze solving algorithms are readily available. With less demand for computation speed and with the assurance that the best run gives the smallest number of cells travelled, the modified flood fill algorithm is, by far, the most commonly used one in micromouse competitions.

When our electrical engineering students join the micromouse team, they have completed only one introductory level programming course: Programming for Electrical Engineers – the only programming course required in their curriculum. For some of them, calling a function recursively is a distant concept. Yet, the modified flood fill algorithm uses the following recursive steps to update the neighboring cells ⁶:

1. Push the current cell location (x,y) onto the stack.
2. Repeat this step while the stack is not empty.
 - a. Pull the cell location (x,y) from the stack.
 - b. If the minimum distance of the neighboring open cells, md, is not equal to the present cell's distance - 1, replace the present cell's distance with md + 1, and push all neighbor locations onto the stack.

To assist the students in learning this algorithm, we rely on visual aids – PowerPoint slides which animate the distance updates and stack contents. Each slide will show the distance update for a particular cell and the state of the stack at the time. It also illustrates the recursive process of the distance update, step by step, until the stack is empty. After the students have studied these animated power point slides, they followed the algorithm and hand-traced the distance update values and the contents of the stack. They checked the distance values with the maze-solver simulator.^{7,8} They re-did the hand traces until all distances were correct. In the end, they found that the animated power point slides were indispensable and these slides had shortened their algorithm learning time. A snapshot of the animated PowerPoint slide is shown in Figure 6.

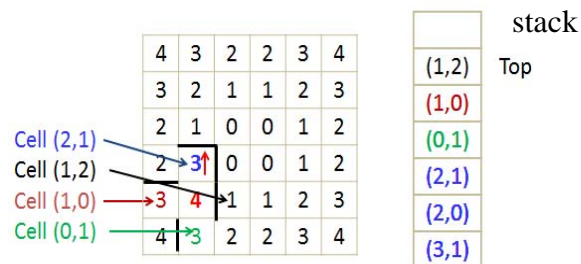

Figure 6. Snapshot of the animated PowerPoint slide

Design/Software Depository and Version Control

Normally, the students will deposit their design in a shared Google drive or post it on Google group forum for other members of the team to download. For each revision, the students will rename the design file so that the other team members know that it is a newer version. Occasionally, the students either forget to rename the file for the newer version or rename it

incorrectly. This incident has wasted time unnecessarily. Furthermore, manually keeping track of the revision contents is a daunting task. Thus, we must find a better system of version control and depository to replace our archaic system.

We considered two types of revision control systems: centralized version control system and distributed version control system.^{9,10} Each of these version control system manages changes of files including software or design files, record the changes, and keep the history of changes as version of the files. The centralized version control system does all of these tasks in a centralized depository where each member of project retrieves the latest revision and commits (stores) the revised version. In contrast, each member of the project in the distributed version control system has a local depository. The team members will retrieve the revised file from a common depository, work on it in the local depository, and has the option of committing (storing) the revised version in the common depository or shares the changes with other members outside the common depository and commit the changes to the common depository when so desired.

In July 2011, the Google Code Project Hosting started to support Git in addition to the previously supported Subversion and Mercurial version control systems.¹¹ We evaluated the Subversion (a centralized version control system) and Git (a distributed version control system) hosted by Google; we decided to use Git for the following reasons:¹²

1. Faster to download a complete depository.
2. Students can share any revisions among themselves and commit the revisions to the common depository when so desired.
3. When the server for the common depository fails, the students can push the local copy of the depository to another server that hosts Git and start working again.

We tried the Google hosting of Git which works well for small files. For larger files, the commit either takes multiple trials to succeed or never succeed at all. The failure may be attributed to the young infancy of Git support at Google. As a result, we now return to the archaic version control system. Hopefully, for the next micromouse groups, Google has fixed all bugs or we could look at the GitHub hosting of Git.

Conclusion

The shortcoming of our curriculum flow became obvious while we were migrating from microcontroller-based micromouse design to system-on-chip design. The needed courses for the micromouse team should have been scheduled earlier in the junior year. The lower level courses should carry the students from the design concept all the way to printed circuit board progressing thorough hierarchical design, hierarchical schematic drawing, simulation/testing, printed circuit board layout drawing, and finally making the printed circuit board. The lower level software course should also use a version control system preferably a distributed version control system such as Git. Using graduate students to assist the undergraduate students mends some of the problems. The ultimate goal, however, is to have a micromouse team that consists of only undergraduate students who are able to tackle the problems by themselves.

Acknowledgment

The authors thank Dr. Ali Amini, Chair of Electrical & Computer Engineering, California State University, Northridge, for going out of his way to support the project. They also thank the ASEE reviewers for their constructive suggestions.

Bibliography

1. N. Chen, H. Chung, and Y. Kwon, "Integration of Micromouse Project with Undergraduate Curriculum: A Large-scale Student Participation Approach", *IEEE Trans. on Education*, vol. 30, no. 2, pp. 136-144, May 1995.
2. CSUN Electrical Engineering Senior Course Electives, available: <http://www.ecs.csun.edu/ece/docs/EE%20Curriculum%20Flow.pdf>
3. J. Peatman, "Design with Microcontrollers", New York, NY: Mcgraw-Hill, 1988.
4. W. Wolf, "Computers as Components", San Francisco, CA: Morgan Kaufmann, 2005.
5. DE0-Nano FPGA Development Kit, Terasic Corp.
6. G. Law, "Quantitative comparison of flood fill and modified flood fill algorithms", *IJCTE International Journal of Computer Theory and Engineering*, vol. 5, no. 3, pp. 503-508, June 2013.
7. L. Last, N. Veun, V. Frey and J. Smith, "Maze-Solver Simulator". Available: <http://code.google.com/p/maze-solver/downloads/list>, 2010.
8. G. Law, "Augmented and revised maze-solver". Available: <https://github.com/glaw-csun/svn/downloads>, 2012.
9. B. Collins-Sussman, B. Fitzpatrick, and C. Pilato, "Version Control with Subversion", Sebastopol, CA: O'Reilly Media, Inc., 2004.
10. J. Loeliger, "Version Control with Git", Sebastopol, CA: O'Reilly Media, Inc., 2009.
11. Google Project Hosting, available: <http://code.google.com/p/support/wiki/FAQ>
12. Why is Git Better than Subversion, available: <http://stackoverflow.com/questions/871/why-is-git-better-than-subversion>

Retention Strategies for Engineering and Computer Science

High Impact Practices (HIP) during first year in college

Raman Unnikrishnan and Victor H. Delgado

College of Engineering and Computer Science

Hye Sun Moon and Edward Sullivan

Office of Institutional Research & Analytical Studies
California State University Fullerton, Fullerton, CA 92831

Abstract

The High Tech Education working group of the President's Council on Jobs and Competitiveness (Jobs Council) concluded that an increase in the number of U.S. engineering and computer science graduates is essential to maintain US competitiveness in the world. Accordingly, the National Science Foundation has embarked an initiative to increase the BS graduates in these disciplines by 10,000. However, engineering and computer science majors share the dubious honor of not retaining most of the students entering the programs as freshmen. The problem is much more severe among underrepresented students that make up an increasing fraction of entering freshmen at California State University Fullerton (CSUF). Studies such as the recent work by ASEE (2012) document over 60 strategies and practices to increase retention during the first two years of the undergraduate program. The strategies were divided into three categories: *student-focused strategies and practices; faculty-focused strategies and practices and department-focused strategies and practices*. The College of Engineering and Computer Science (ECS) at CSUF contributed its own practices and findings to the ASEE study, was acknowledged for its work and was recognized nationally by the Wal-Mart *Semillas* grant and *Excelencia's* Growing What Works initiative. This paper examines the causes of poor retention during the first year as well as the successful deployment of high impact practices to improve it. The approach taken by CSUF started with a careful and dispassionate review of student data with the help of the Office of Institutional Research and Analytical Studies. This data based inquiry naturally led to the identification of numerous problems and surprisingly several remedies also. ECS first-year retention has improved between 15 and 20% during the past five years. The approaches, analyses and results of the CSUF experience are expected to be useful to all, particularly for institutions with large populations of first-time college goers or underrepresented minorities.

1. Background

High-Impact Practices are defined as purposeful and effective educational practices which deepen student engagement and learning leading to college student success.³⁹ Through years of analyzing student gains Kuh found that students who participate in high-impact educational practices have higher student engagement gains than their peers. He recommends that students

Proceedings of the 2013 American Society for Engineering Education Pacific Southwest Conference
Copyright © 2013, American Society for Engineering Education

receive these high-impact learning experiences in the first year of college. Many of Kuh's high impact learning experiences have been adapted at CSUF.¹¹ These high-impact practices are positively associated with persistence and GPA, higher rates of student-faculty interaction, increases in critical thinking and writing skills; and higher student engagement overall^{2,10,11}.

The College of Engineering and Computer Science (ECS) at California State University Fullerton (CSUF), a comprehensive Hispanic-Serving Institution in Orange County, California, implemented an “*Engineering and Computer Science (ECS) Scholars*” program during 2007-10 to increase the retention rates of freshman Latino students in ECS majors. The program integrated curricular and co-curricular educational interventions designed to support students' academic, social and personal transition to college life and increase their achievement, retention and graduation rates. Early results of this special *ECS Scholars* program were powerful, with an average of 81% one-year and 71% two-year campus wide retention rates compared to 73% one-year and 63% two-year campus wide retention rates of all ECS freshman, and serve as the basis for this paper.

The National Science Board (2004) has noted “a troubling decline in the number of U.S. citizens who are training to become scientists and engineers, whereas the number of jobs requiring science and engineering...training continues to grow.” Casting that decline in a particularly disquieting light is the fact that significantly fewer U.S. college students are pursuing science and engineering degrees than their counterparts in other countries. As reported in *Rising above the Gathering Storm, Revisited* (2010), the U.S. now ranks 27th among developed nations in the proportion of college students receiving undergraduate degrees in science or engineering. Moreover, there is a large degree of variability in retention and graduation of students by race, ethnicity, and gender. For example, the six-year graduation rate of Asian Americans is 67%, Caucasians, 60%, Hispanics, 44%, Native Americans, 39%, African Americans, 38% and females, 61%¹⁻¹². In California, about a third of the state's students who intend to pursue engineering and computer science graduates degrees fail to achieve their goal, considerably higher than the 22% attrition rate nationally. While the state is home to more top research universities and high tech industries than any other state, it is significantly under-producing graduates with technical degrees³.

In order to increase the number of engineering and computer science graduates, the underrepresentation of Hispanic students in engineering and computer science graduates needs to be addressed in California and particularly in Orange County where Hispanics make up 38% and 31% of the population respectively. Projections show that Hispanic students will represent 20% of U.S. high school seniors by 2013, yet they make up only 13% of community college graduates, 10% of university graduates, and 6% of STEM graduates (U.S. Census Bureau, 2012; U.S. Department of Education, 2010c; U.S. Department of Education, 2010d; Taningco et al., 2008). Similarly, low-income students are also seriously underrepresented in higher education and, by extension, STEM majors. For every 100 low-income students who make it to high

school, 65 will graduate, 45 will enroll in college (75% at a community college), and only 11 will earn a college degree.

2. Need for Improvement of Retention in STEM

The President's Council on Science and Technology's *most recent report* (PCAST 2012) finds that high performing students frequently cite uninspiring introductory courses as a factor in their decision to switch majors. Low performing students with a high interest and aptitude in STEM careers often have difficulty with early courses in mathematics and find little help provided by their universities. Moreover, many students, and particularly members of groups underrepresented in STEM fields, cite an unwelcoming atmosphere from faculty in STEM courses as a reason for their departure. Among the PCAST 2012 recommendations³⁷ to improve STEM education are 1) improved teaching methods by university faculty to make courses more inspiring; 2) providing more assistance to students facing mathematical challenges; 3) creating an atmosphere of community for STEM learners; and 4) diversifying teaching methods in STEM education. Data show that evidence - based teaching methods are more effective in reaching all students - especially the “underrepresented majority”- the women and members of minority groups who now constitute approximately 70% of college students but only 45% of undergraduate STEM degree recipients.¹³⁻²³

3. Overview of Enrollment and Graduation Data at CSUF and the College of ECS

California State University, Fullerton (CSUF), located 25 miles southeast of Los Angeles in Orange County, is among the largest universities in the nation with a fall 2012 enrollment of 37,677 students. CSUF is the largest of the 23 campuses of the California State University (CSU) in terms of student headcounts, which grants more than 50% of all bachelor’s degrees and 30% of all master’s degrees in the state. It is Orange County's only four-year, comprehensive Hispanic-Serving Institution and Asian-Pacific Islander-Serving Institution. There is no ethnic majority among its students; 32% of students identify as Hispanic, and more than half come from families in which neither parent graduated from college. Among the first-time freshman entering CSUF in 2011, 40% were identified as low-income, per federal criteria (received Pell Grant) - all factors identified in the literature as contributing to leaks in the STEM pipeline.

CSUF ranks first in California and fourth in the nation in bachelor’s degrees awarded to Hispanics⁸ and is ranked ninth nationally in the number of baccalaureate degrees awarded to minority students (*Diverse Issues in Higher Education*, 2011).

a. Enrollment and Graduation Data at CSUF

Table 1 shows undergraduate enrollment data and the percentage of students who achieved the dean’s list or academic probation in the overall CSUF student population, in all STEM majors and in the College of Engineering and Computer Science (ECS). By the end of the fall 2011

Proceedings of the 2013 American Society for Engineering Education Pacific Southwest Conference
Copyright © 2013, American Society for Engineering Education

semester, approximately 5% of CSUF’s undergraduate student population chose majors in ECS. Just 9% of these students made dean’s list, compared to 13.6% across all majors. Moreover, 16% of ECS majors were on academic probation, compared to 7.6% across all majors. Nearly twice as many students make dean’s list as those on academic probation university-wide while in ECS, nearly twice as many students are on academic probation compared to the number who achieves dean’s list.

Table 1. Undergraduate STEM and ECS Enrollments, End of Fall 2011 Semester

	Undergraduate students	Dean’s List	Academic Probation
All University	30,655	13.6%	7.6%
STEM	4,919	9.1%	10.0%
ECS	1,641 (5.4% of total student population)	9.0%	16.0%

Table 2 shows CSUF graduation figures, with persistence rates by STEM majors and ECS majors. “Persistence” means that a student initially declaring a major in a discipline completed a degree in that discipline within six years. The persistence rate for all CSUF students was 82% with 53% of STEM majors persisting and 51% of ECS majors persisting. The overall graduation rate for the seven cohorts was 49%, with STEM students again completing degrees at lower rates (38%) and ECS majors at 14%.

Table 2. Undergraduate STEM and ECS Persistence and Six Year Graduation Rates, Entering Cohorts 1998-2004

	Persistence	Six-Year Graduation Rate
All University	80 %	50 %
STEM	61 %	19 %
ECS	60 %	14%

STEM students take more years to graduate than non-STEM students. However, the College of Engineering and Computer Science (ECS) have made significant progress in improving retention and reducing time to degree as discussed in the next section.

b. University Level Retention Efforts at CSUF

In January 2010, a University-wide task force examined the campus’ graduation rates for the past 10 years and identified challenges, as well as strategies for addressing the challenges, to increase graduation rates. As a result of its activities, some of the specific changes that occurred are:

- Reexamination and implementation of a more integrated student orientation, academic advising and course registration process.

*Proceedings of the 2013 American Society for Engineering Education Pacific Southwest Conference
Copyright © 2013, American Society for Engineering Education*

- Identification of bottleneck STEM courses, and new initiatives on how to alleviate the problem, including the use of supplemental instruction utilizing peer leaders.
- Comprehensive analysis and inventory of all advising practices, academic support services and student affairs to identify overlaps and gaps in the system. The information is being used to realign resources to create a more intentional and proactive advising infrastructure so that students do not get lost or drop out of the system.
- Assessment of course registration behaviors of the 2009 class led to identifying students in good standing who had not registered for courses during the first class registration period. These students were contacted by associate and assistant deans, Academic Advising Center staff and Intensive Learning Experience staff to determine why they had not registered and encourage them to do so if at all possible. The primary reason reported for non-registration was financial. The continuation rate in Fall 2010 was 84.3%, more than four points higher than the previous year (80.2%).

A campus-wide academic advising workshop trained 134 participants (74 faculty, 46 staff and 15 students) on the degree audit process, new General Education realignment, probation and disqualification procedures, evidence-based best advising practices, reasons for graduation deferrals, measures to prevent graduation deferrals and advising technologies. 96-98% of respondents agreed that the workshop material was relevant and appropriate and rated it as excellent or above average.

The majority of the CSUF students will be among the first-generation of their family to earn a college degree. The student population is highly diverse (no majority ethnic-race). The university population is predominantly female but the ECS population is majority male by a wide margin. As a regional university, CSUF draws the majority of its student body from the Orange County, Southeast Los Angeles County, Riverside County, and San Bernardino County areas of Southern California (See Table 3). The ethnic and gender mix of entering freshmen at the university is shown in Table 4.

Admission to the university referenced in Tables 3 and 4 is based on the “Eligibility Index (EI)” established by the California State University system. Eligibility index is a composite score obtained by the formula $EI = \text{High school GPA} * 800 + \text{SAT Mathematics and SAT Critical Reading}$. For example, a student with 3.2 GPA in high school, SAT Critical Reading score of 500 and mathematics score of 600 will have an EI of $3.2 * 800 + 500 + 600$ or 3660. (Alternatively, $EI = 200 * \text{GPA} + 10 * \text{ACT score}$.) Campuses use lower or higher eligibility scores based on local needs, demand and selectivity but the admission standards do not address success in prerequisite courses including mathematics. In the past it was possible for students seeking to be engineering and computer science majors with remediation needs in high school algebra and trigonometry.

The enrollment in the programs within engineering and computer science had been steadily increasing, thanks to the increasing regional and national visibility of the college as well as the success of outreach activities. This has also improved selectivity for entrance. After lagging

behind the university's minimum eligibility index for many years, ECS students have recently edged out the university at large (See Table 5) albeit slightly. One and two year attrition rates for the College of ECS historically exceeded the university rates by a wide margin but, thanks to the recent college-level efforts, the attrition rates are shrinking as shown in Table 6. This results in an increased need for ECS to focus its efforts to improve student outcomes on the freshman and sophomores years in order to begin to make progress in improving its six year graduation rates.

Table 3. Geographical Distribution of Enrollment at CSUF and the College of Engineering and Computer Science³⁸

Five Year Trend in Undergraduate enrollments by county of residence	CSUF/ECS	Fall 2008	Fall 2009	Fall 2010	Fall 2011	Fall 2012
Orange	CSUF	48%	48%	52%	53%	53%
	ECS	48%	46%	51%	53%	52%
Los Angeles	CSUF	28%	28%	25%	24%	24%
	ECS	26%	26%	24%	21%	22%
Riverside	CSUF	7%	8%	7%	8%	8%
	ECS	9%	10%	10%	9%	10%
San Bernardino	CSUF	7%	7%	7%	7%	7%
	ECS	6%	7%	6%	7%	7%

Table 4. Enrollment Profile of California State University Fullerton and the College of Engineering and Computer Science³⁸

Five Year Trend in Undergraduate enrollments	CSUF /ECS	Fall 2008	Fall 2009	Fall 2010	Fall 2011	Fall 2012
Asian/Pacific Islander	CSUF	22%	22%	22%	22%	22%
	ECS	24%	25%	26%	25%	25%
Hispanic	CSUF	30%	31%	33%	34%	35%
	ECS	31%	31%	32%	33%	33%
White	CSUF	30%	30%	30%	29%	27%
	ECS	26%	26%	26%	26%	24%
Will be among first generation of family to earn a college degree	CSUF	50%	52%	52%	53%	55%
	ECS	50%	51%	50%	48%	50%
Women	CSUF	58%	58%	57%	56%	56%
	ECS	13%	13%	12%	12%	11%

*Proceedings of the 2013 American Society for Engineering Education Pacific Southwest Conference
Copyright © 2013, American Society for Engineering Education*

Table 5. Admission Characteristics of Entering Freshmen at CSUF and ECS³⁸

Entry Characteristics Trend for First-time Freshmen: <i>Five-Year trend</i>	CSUF/ECS	Fall 2008	Fall 2009	Fall 2010	Fall 2011	Fall 2012
Eligibility Index	CSUF	3542	3611	3620	3719	3742
	ECS	3479	3509	3631	3707	3743
Needed Math Remediation at Point of Admission	CSUF	37%	35%	32%	24%	23%
	ECS	22%	21%	13%	13%	13%

Six year graduation rates for ECS cohorts lag the university rates by a large margin. While six-year graduation rates of the university are approximate 50%, rates for students initially entering as ECS majors are near 30% (Table 7). The ECS first-time freshman cohort of over 300 students impacts the overall university rate by being 10 percentage points in an overall rate of 100 points. The failure to graduate students who entered as ECS majors in six years or less from an engineering program or from any other university programs thus draws down the overall university rate by approximately one percentage point. ECS outcomes lower the university six-year graduation rates of male students by two percentage points. All of this points to the need for focused attention to retention of freshmen students within ECS.

Table 6. Retention Rates of Entering Freshmen at CSUF and ECS³⁸

First-time Freshman One- and Two-year Retention Rates by Cohort Entry Term: <i>Five-Year Trend</i>	CSUF/ECS	Fall 2007	Fall 2008	Fall 2009	Fall 2010	Fall 2011
One-Year Retention rate	CSUF	79%	80%	84%	85%	88%
	ECS retained at CSUF	68%	71%	83%	81%	85%
	ECS retained as ECS major	52%	52%	69%	69%	71%
Two-Year Retention rate	CSUF	70%	73%	79%	78%	
	ECS retained at CSUF	59%	62%	78%	72%	
	ECS retained as ECS major	34%	40%	49%	51%	

Examination of graduation rates for entering ECS cohorts reveals students who entered initially seeking ECS majors are unlikely to graduate with ECS degrees. Fifteen percent of the ECS majors entering as first-time freshmen in Fall 2006 ultimately graduated with a degree in ECS.

Twenty three percent of the students from the initial Fall 2006 ECS cohort earned a degree in six years or less from a major outside of ECS.

The retention and graduation rates of first time ECS majors are most impacted by the first year attendance. So, it became apparent that efforts for increased contact with ECS freshmen during the first year of college attendance and during the first semester classes they take (See Table 8) need to be undertaken. Remediation in mathematics was another challenge. So, ECS altered the first year experiences of its entering class starting with wholesale changes to its new student orientation and first year experiences available to its students.

Table 7. Six Year Graduation Rates for Entering Freshmen³⁸

Five Year Trend First-time Freshman Six-year graduation rates by Cohort Entry Term	CSUF/ECS	Fall 2002	Fall 2003	Fall 2004	Fall 2005	Fall 2006
Six-year graduation rates	CSUF cohort (includes ECS majors at entry)	49%	52%	51%	50%	51%
	ECS major at entry earned degree in any major including ECS at CSUF	32%	40%	34%	31%	38%
	ECS major at entry earned degree in ECS major	11%	15%	14%	11%	15%

Table 8. First Semester Courses Taken by First Time Freshmen³⁸

Course attempted by ECS first-time freshmen in year one Fall (% of ECS freshmen)	Fall 2008	Fall 2009	Fall 2010	Fall 2011	Fall 2012
Remedial math	17%	17%	10%	10%	10%
Pre-calculus	57%	58%	65%	65%	57%
Calculus	12%	11%	16%	21%	28%
Computer Science	29%	27%	29%	34%	39%
Engineering	30%	13%	30%	39%	37%
At least one Engineering or Computer Science course	59%	41%	58%	73%	76%

4. Specific Efforts for Improving ECS Retention in the First Year

As mentioned above, the retention during first year was addressed using a variety of approaches. They included ECS Scholars Program using an opportunistic Title V grant, a scaled down effort using a *Semillas* Award obtained in 2009, academic adjustments by reordering choke points in the curriculum to a later, more mature, stage, improved connections and advising during new student orientation, creating affinity groups such as ‘Women in Engineering,’ peer mentoring programs, and intervention approaches during probation and disqualification due to low grades. Also, efficient utilization of support services from campus forums such as Freshman Programs, the University Learning Center (ULC) and Center for Academic Support in Engineering and Computer Science (CASECS) is also part of the retention strategy. While every one of these strategies contributes in some meaningful way in helping a few students succeed during the first year, the combined impact of these high impact practices continues to be substantial.

a. ECS Scholars Program Title V - Integration of Services

The Engineering and Computer Science (ECS) Scholars program is a learning community (LC) based model that integrates interventions from four different entities at CSUF: Title V Retention Programs, the University Learning Center (ULC), the Center for Academic Support in Engineering and Computer Science (CASECS) and the Freshman Programs. Service allocation and delivery is coordinated by a Student Services Professional (SSP). The *ECS Scholars* program launched in the fall 2007 semester focuses on the academic success of Latino *first-time freshmen* (FTF) in engineering and computer science. Students participate in this program during the fall and spring semesters of their first year. As mentioned earlier, this program integrated interventions designed to support Latino student’s academic, social and personal transition to college life and ensure success. Program staff and services provided by the program are tailored to be culturally relevant to ECS Latino students.

Program Activities

ECS Scholars is an elective program; participants experience a smooth transition to college life by maximizing campus resources, opportunities for individual and community development, and on-going interaction with faculty, staff, and peers from the College of ECS. The ECS Scholars LC offers rewarding and unique benefits centered on the following aspects:

- Develop friendships and connections with students and faculty within the College of ECS. Students are block scheduled and placed in a Freshmen Year Seminar (FYS) course each semester of their first year (1 unit in the fall and 2 in the spring semester) with an instructor who holds a Ph.D. in Engineering or Computer Science.
- Receive specialized academic advisement for general education and major coursework under the guidance of a full-time academic advisor.

- Receive supplemental instruction and one-on-one tutoring in core classes (math, science, engineering and computer science courses) in specialized Freshmen Interest Groups lead by trained upperclassmen.
- Service-learning experience related to their field of study; students must complete 20 hours at government or non-profit organizations.
- Receive counseling on transitional issues from a student service professional who is a co-instructor in both sections of the FYS courses.
- Mid semester grade check (early intervention) to connect academically at-risk students with university or college level support services to help them succeed in their classes.

b. Excelencia in Education Wal-Mart Semillas Grant– *Scaled Down Integration of Services*

In early 2009 the Title V grant (with annual allocation of \$160,000) ended but ECS received a smaller funding of \$50,000 from the Excelencia in Education Foundation from their Wal-Mart *Semillas* grant. One of the outcomes observed that has paved the way to offer variations of the ECS Scholars program with limited funding, was the opportunity to restructure portions of the ECS Scholars program. The program was eventually mainstreamed at the conclusion of the grants with the Assistant Dean leading the efforts and most of the advising, tutoring and mentoring services channeled through CASECS.

During the fall 2010 semester 26 students participated in the learning community. By block scheduling the students, it was possible to offer study groups and bring them together in two courses, University 100 and Engineering 100 (EGGN 100). This activity is to be one of the most important components for student success and is identified as one of the high impact educational activities for student success. According to their ASEE paper, Unnikrishnan and Lopez state the following: “*Learning Communities have three integral components: shared knowledge, shared knowing, and shared responsibility. Connecting courses so that they appear to be related promotes the networking of ideas and elevates thinking to a higher level (shared knowledge). Enrolling participants in the same classes induces social interaction and enhances intellectual interface, and allows students to care for the development of each other's learning (shared knowing). Lastly, students who participate in LCs learn to become responsible for one another and become "mutually dependent" so that advancement is done as a cohesive unit with each member making contributions to the group (shared responsibility)*¹⁸⁻¹⁹.” A total of 129 ECS first-time full-time students participated in the programs for three academic years in 2007, 2008, and 2010. Data in the tables 9 and 10 indicate that those who were in the ECS Scholars Program had a higher persistence rate. One year retention rate of ECS Scholars freshmen was 71%, while only 58 % of all ECS freshmen had been retained for one year. Similarly, two-year retention rate of ECS Scholars was 10% higher than that of all ECS freshmen. Therefore, student involvement in a small learning community sharing knowledge and academic goals was found to be an effective educational intervention to improve freshmen retention, particularly for underrepresented students.

c. University Learning Center

The ULC provided study groups for remediation courses such as Math 40, Math 125 and Math 150A Calculus I. These courses had been identified as choke points where ECS students struggle and often fail. In addition to the study groups, the ULC offered tutoring in English, chemistry, computer science and provided study skills workshops. The workshops included, time management, note taking, and test taking strategies.

Table 9 *In-ECS* Retention Rates

First-Time Freshmen ECS SCHOLARS in ECS (2007, 2008, 2010 Cohort)³⁸

Cohort Year (Fall)	# of ECS Scholars	1-year Retention	2-year Retention
2007	59	40 (68%)	28 (47%)
2008	44	31 (70%)	23 (52%)
2009*	n/a	n/a	n/a
2010	26	20 (77%)	16 (62%)
Total	129	91 (71%)	67 (52%)

* ECS Scholars Program was not available for 2009 cohort

Table 10 *In-ECS* Retention Rates

First-Time Full-Time Freshmen ALL in ECS (2007, 2008, 2010 Cohort)³⁸

Cohort Year (Fall)	# of ECS Cohort	1-year Retention	2-year Retention
2007	325	170 (52%)	110 (34%)
2008	353	184 (52%)	141 (40%)
2010	331	229 (69%)	168 (51%)
Total	1009	583 (58%)	419 (42%)

d. Freshman Programs

At CSUF “**Freshman Programs**” is an entity on campus that promotes college success by providing learning communities designed to ensure first-year students' successful transition from high school to higher education. Its curriculum and services create a foundation for academic

*Proceedings of the 2013 American Society for Engineering Education Pacific Southwest Conference
Copyright © 2013, American Society for Engineering Education*

achievement, campus involvement and community engagement. Freshman Programs promotes student retention through academic success, campus involvement and community engagement.

Freshman Programs facilitated the following for the ECS scholars program: (1) enrollment in a Freshmen Year Seminar (FYS) Course that is vital to academic planning, orientation, and transition to CSUF; this seminar offers further integration into areas of Engineering and Computer Science via a Service Learning component, (2) coordination of block-scheduling of participants (3) professional development for FYS Course instructors; and (4) assessment of all professional development programs as well as peer evaluations for instructors.

e. Women in Engineering

In 2012, ECS received funding from the Engineering Information Foundation to support a "Women in Engineering" learning community project. Nineteen, out of 58 entering first-time freshman female students, are participating in the learning community during the Fall and Spring semesters of AY 2012-13. A tutor and a mentor for this community were hired and female role models have been invited to interact with the group. Field tours such as the one to the Disneyland Resorts were arranged to witness the work done by female engineers in nonconventional venues.

f. Creation of an Undeclared Engineering Option

It has been observed at CSUF that about 25% of the entering freshmen in engineering may not be ready to declare a major largely due to a lack of information regarding difference between the disciplines within engineering. Some students may be genuinely torn between two disciplines they like equally. In the past, these students were advised to choose one of the available majors with the understanding that they could transfer to a different major later. However, such transfer occurred rarely; instead students left the college altogether when they became disenchanted with the initial choice. Today, all undeclared majors are required to take *EGGN 100 Introduction to Engineering* where they are introduced to the various branches of engineering. Early indication is that the retention rate among undeclared freshmen is high; formal evaluation of the data is still in progress.

g. EGGN 100 Introduction to Engineering

The College of Engineering and Computer Science has allocated resources to offer a 3 unit introductory course, EGGN 100. ECS Scholars were required to register for this course which is part of the block scheduled courses. This course was team taught by selected untenured faculty members with a reputation as excellent teachers.

Students who are enrolled in the course will have a general understanding of four engineering disciplines including Civil Engineering, Electrical Engineering, Computer Engineering, and Mechanical Engineering to gain hands-on experience of engineering tools and to work

collaboratively in team projects. Faculty-Student interaction has consistently been found as a strong correlate of successful learning²⁶⁻³⁴. According to Vygotsky’s “Zone of Proximal Development Theory (1978)”, learning can be enhanced when students work in collaboration with more capable peers³⁵⁻³⁶. In EGGN100 classes, students are able to interact with peers, faculty, and graduate students who are more capable peers.

ECS Freshmen who take EGGN100 course are more likely to return to ECS major in 2nd year (see Table 11 and Table 12)³⁸. In 2010, 73% of freshmen who took EGGN100 persisted in the engineering major, whereas 68% of freshmen who did not take the course returned to ECS in 2nd year. The difference in 1-year retention is more salient for 2011 cohort, indicating that 81% of 2011 freshmen cohort returned to ECS in 2nd year.

Table 11. The Effects of EGGN 100 on 1-Yr Retention of ECS Fall 2010 Freshmen Cohort³⁸

inECS Status	EGGN100		Total
	NOT taken	taken	
Changed Major/Dropped Out	104	8	112
In ECS Retained	221	22	243
Total	325	30	355

In ECS Status	EGGN100		Total
	NOT taken	taken	
Changed Major/Dropped Out	32.0%	26.7%	31.5%
In ECS Retained	68.0%	73.3%	68.5%
Total	100.0%	100.0%	100.0%

Table 12. The Effects of EGGN 100 on 1-Yr Retention of ECS Fall 2011 Freshmen Cohort³⁸

In ECS Status	EGGN100		Total
	NOT taken	taken	
Changed Major/Dropped Out	99	5	104
In ECS Retained	230	21	251
Total	329	26	355

In ECS Status	EGGN100		Total
	NOT taken	taken	
Changed Major/Dropped Out	30.1%	19.2%	29.3%
In ECS Retained	69.9%	80.8%	70.7%
Total	100.0%	100.0%	100.0%

h. Supplemental Instruction

Even though the ECS frowns on additional credit hour burden created by the supplemental instruction, such extra instruction has proven to be one more item in ensuring student success in gatekeeper courses⁴⁰. Some students benefited by supplementary instruction especially in mathematics.

i. CASECS (Center for Academic Success in Engineering and Computer Science)

The Center for Academic Support in Engineering and Computer Science (CASECS) is an academic support program designed to recruit, retain and graduate students. CASECS serves educationally disadvantaged students, to the extent possible by law, emphasizes participation by students from groups with low eligibility rates for four-year colleges. Some of the features of the program include:

1. Building a support community among students with similar career goals
2. Constructing the bridges necessary to establish a mentor-protégé relationship between faculty and students
3. Expecting excellent performance by students

j. Freshmen Advising: Bucking Against the Campus Culture of *General Education First*

One of the quickest ways of discouraging an engineering or computer science student is through advising the student to take all general education courses first. Such advice was very common until relatively recently because the campus culture promoted wanderings of undeclared freshmen. Once the student takes all general education courses without simultaneously progressing in technical courses or foundational courses in mathematics and science, the student finds himself or herself unable to take courses or an adequate number of courses for lack of prerequisites. This practice has essentially stopped by the intervention of ECS administration and the constant dialog it has with Freshmen Programs as well as the staff of New Student Orientation.

k. New Student Orientation (NSO)

ECS NSO Model

With the goal of establishing a connection from the beginning and allowing first-time freshmen to “experience” their major earlier in their academic career, ECS collaborated with the Academic Advisement Center and the New Student and Parent Programs and added an innovative component in 2010 to the summer NSO sessions. The afternoon session of the NSO is now held in the ECS labs. The students, grouped by major, spend an afternoon with their department chair, faculty members and administrators. Activities include lab tours, academic advisement where general education and major requirements are presented along with how to register for classes.

*Proceedings of the 2013 American Society for Engineering Education Pacific Southwest Conference
Copyright © 2013, American Society for Engineering Education*

The interactive NSO sessions have resulted in an increased level of interaction between faculty and student, allowed students to “experience” their major earlier in their academic career, increased the level of peer interaction among students within the College and created opportunities for students to immediately “connect” with their future instructors and advisors.

Placement in correct Math course

Many freshmen are quite gullible and naïve about course selections especially when they are first generation college goers. There have been many instances where students with transferable AP scores in mathematics (AB or BC) are placed inappropriately in pre-calculus courses since scores are not available at the time of orientation. Sadly, some of these instances are not minor clerical errors. So, ECS welcome letter now includes specific directions about mathematics placement and avoiding a second serving of pre-calculus while waiting for advanced placement scores.

Math Qualifying Exam (MQE)

Many students with good mathematics skills arrive for NSO without expecting a ‘test.’ They invariably failed to make the cut when asked to take the MQE that is administered during new student orientation. The scores in such “gotcha” tests meant little but low scores forced AP students into pre-calculus courses. ECS instituted coaching for the MQE examination by sharing tips for taking the test. Information on the MQE is also provided on the checklist sent to students and is also covered during NSO. The MQE scores are becoming more reliable as a result.

Chemistry Placement Exam (CPE)

Students failed to reach the cut-off threshold if they arrived without reviewing high school chemistry and are then placed in basic chemistry courses that totally upset their curricular flow. So, ECS includes information about CPE in the checklist that is sent to accepted students.

5. Further Thoughts

As can be seen from the discussion above, a number of individual high impact strategies have resulted in a cumulative improvement in the retention of first time freshmen in the College of Engineering and Computer Science. However, the gains in the first year retention have not been matched by similar gains in the second year, a critical gap in improving graduation rate. At the present time, the College is contemplating on a program with the following well-defined objectives: 1) increase the number of students obtaining baccalaureate degrees in ECS at CSUF; 2) reduce the time to graduation for ECS students; 3) continue to improve the retention of freshman students; and 4) increase retention of sophomore ECS students. The targeted goals are ambitious; however, they are based on the proven results of first year retention. These goals are depicted in tabular form in Table 13.

Table 13. Expected Retention and Graduation Outcomes³⁸

Cohort year	Total Head Count of Freshmen	Persist to 2nd year	Persist to 3rd year	Persist to 4th year	Grad in 4 years	Enter 5th year	Grad in 5 years	Enter 6th year	Grad in 6 years	> 6 years to grad
		85%	70%	65%	35%	30%	50%	60%	60%	5%
2013	550	468	385	358	193	165	275	330	330	28
2014	600	510	420	390	210	180	300	360	360	30
2015	600	510	420	390	210	180	300	360	360	30
2016	650	553	455	423	228	195	325	390	390	33
2017	650	553	455	423	228	195	325	390	390	33

In other words, the following are the aspirations of ECS:

1. **Increase the number of ECS graduates who complete STEM baccalaureate degrees within six years by 60%.** There are currently 496 freshmen in the 2012 cohort. Of the expected 550 freshmen in the 2013 cohort, 330 (60%) will be on track to graduate within six years. In the fall 2005 cohort, only 35 of 328 freshmen (10%) were on track to graduate within six years.
2. **Reduce time to graduation. Increase by 44% the number of students graduating within five years and increase by 34% the number of ECS students graduating within four years.** Of the 550 expected freshmen in the 2013 cohort, 193 (35%) students will receive their degree within four years and an additional 82 students for a total of 275 (50%) will graduate within five years. In the fall 2005 cohort, only 22 (6%) of 328 students graduated within five years and only 5 (1%) of 328 students graduated within four years.
3. **Increase freshman retention by 35% annually.** In each year of the project, 85% of freshmen will enter the sophomore year. Of the 550 entering freshmen in 2013, 468 (85%) will continue to the second year. In the fall 2005 cohort, 164 (50%) of 328 students continued to the second year.
4. **Increase sophomore retention by 42% annually.** In each year of the project, 70% of sophomores will enter the third year. Of the 550 entering freshmen in 2013, 385 (70%) will continue to the third year. In the fall 2005 cohort, 95 (28%) continued to the third year.

This is an ambitious plan that is rooted in growth with quality. It is labor intensive and therefore too expensive for a public university like CSUF to unilaterally implement. With this plan in mind, ECS is actively seeking external funding for implementation. When such efforts become successful, the college will be able to deploy a multifaceted full-court press towards recruitment and retention of high school seniors and shepherd them through the freshmen and sophomore

years. Well-advised students who are in sync with the curriculum seldom drop out of the program if they have gone beyond the sophomore year.

6. Conclusions

Attrition at the end of freshmen year has been a well-known problem as well as a national scourge in technical education. The problem is significantly more pronounced in engineering and computer science disciplines. While increasing entrance requirements may be one approach, such an option may not be feasible for public universities with mandated admission criteria and a mission to accommodate access. The problem is exacerbated in these universities such as CSUF where the entering freshmen are in large number first generation college goers with modest means. In the past, there was less focus on university wide graduation and retention efforts but it was a matter of survival for ECS. The college unilaterally embarked on an aggressive retention initiative a few years ago and this investment is returning yield handsomely now.

As one can see from the results of the paper, no single solution exists for the complex problem of attrition. Supplementary instruction may benefit a few, a nurturing environment and special attention may help another group, peer mentoring suits another and so on. It has been shown in this paper that by deploying a number of activities during the freshmen year, significant improvement in retention can be achieved. *In short, in the absence of the elusive magical silver bullet to obliterate the offending target, it was found that a collection of BB gun pellets can do just as well.* Thus the many little steps and data driven approaches taken within engineering and computer science, have found to be highly successful.

The College of ECS efforts recognized that a problem existed and that all ECS faculty, staff, and leaders had to be engaged to find solutions. The college did not accept the *status quo* excuse that the rigor of the program was too great for the students and therefore, high attrition was inevitable. Instead, it focused on the causes of student drop out and created relatively small common sense remedies for the problem. Despite funding reductions over the past decade to California public education, the ECS efforts have flourished.

What has been achieved to date is an inclusive, transferable model of effective learning communities with the support of administrators, faculty, staff, and students—one that can be expanded to other four-year institutions throughout the country, amplifying its effectiveness and increasing the number of U.S. students who earn baccalaureate degrees in STEM majors and enter successful and productive STEM careers. Furthermore, since these ideas are tested in an environment where 32% of the students are Hispanic, many strategies are directly transferable to HSI institutions.

The College of Engineering and Computer Science is currently embarking on adapting the success it has had with first year students and extending them to ensure success for second year students. Specifically, the project that is being envisaged will: 1) significantly improve advising,

peer mentoring and community building opportunities; 2) improve learning (and therefore student success) in pivotal mathematics and other introductory courses; 3) improve undergraduate student engagement and leadership opportunities; and 4) institutionalize STEM student learning communities with a few more block-scheduled classes.

Acknowledgement

Dr. Susan Barua, Associate Dean for Engineering and Computer Science and Ms. Ann Ronan, Grant Writer for the Office of Graduate Studies and Research collaborated with the first two authors in developing a proposal that has been submitted for external funding. Their help is acknowledged here since several key aspects of the proposal have been incorporated strategically in this paper.

Bibliography

1. Bringle, R. G., Studer, M., Wilson, J., Clayton, P. H., & Steinberg, K. S. 2010. Designing programs with a purpose: To promote civic engagement for life. *Journal of Academic Ethics*, 30.
2. Brownell, J. E., & Swaner, L. E. 2010. *Five High-Impact Practices: Research on Learning Outcomes, Completion, and Quality*. Washington DC: Association of American College and Universities.
3. California Council on Science and Technology Annual Report. 2006-2007. Available for download at: <http://www.ccst.us/annualreport/2006-7/2006-7AR.pdf>
4. California State University Fullerton 2012. Strategic Plan. Available for download at <http://www.fullerton.edu/>
5. Engage to Excel: Producing One Million Additional College Graduates with Degrees in Science, Technology, Engineering, and Mathematics. February 2012. The President's Council on Science and Technology.
6. Going the Distance: Best Practices and Strategies for Retaining Engineering, Engineering Technology and Computing Students. American Society for Engineering Education. 2012.
7. Gosser, D., & Roth, V. 1998. The workshop chemistry project: Peer-led team learning. *Journal of Chemical Education*. 75, 2, 188
8. Hispanic Outlook in Higher Education, 2012
9. Hudspeth, M. C., ed. 2000. A handbook for academic excellence workshops. Success through collaboration. College of Engineering and College of Science, California State Polytechnic University, Pomona, California.
10. Kuh, G. D., Kinzie, J., Buckley, J.A., Bridges, B. K., & Hayek, J. C. 2006. What matters to student success: A review of the literature. National Postsecondary Education Cooperative (NPEC) Commissioned Paper.
11. Kuh, G. 2008. New directions for institutional research. 2009. Published online www.interscience.wiley.com. DOI: 10.1002/ir.283
12. National Research Council. *Rising Above the Gathering Storm, Revisited Rapidly Approaching Category 5*. Washington, DC: The National Academies Press, 2010.
13. National Science Board. 2004. Science and engineering indicators. National Science Foundation, Division of Resources Statistics. Arlington, Virginia. Available for download at: <http://www.nsf.gov/statistics/seind04/>
14. The National Survey of Student Engagement: Conceptual and Empirical Foundations. *2009 new directions for institutional research*, no. 141. Wiley Periodicals, Inc.
15. Nestor-Baker, N., & Kerkor, S. 2009. "Recruitment and retention of underrepresented students in STEM fields," 2008 annual meeting of the Assoc. of NROTC Colleges and Universities, Daytona Beach, FL.
16. Springer, L., Stanne, M.E., Donovan, S. 2011. Measuring the Success of Small-Group Learning in College-Level SMET Teaching: A Meta-Analysis, *Diverse Issues in Higher Education*. Available for download at <http://www.wcer.wisc.edu/archive/cl1/cl/resource/scismet.pdf>
17. Strayhorn, T.L. 2011 Bridging the Pipeline: Increasing Underrepresented Students' Preparation for College Through a Summer Bridge Program. *American Behavioral Scientist* 55(2) 142–159. SAGE Publications.

Proceedings of the 2013 American Society for Engineering Education Pacific Southwest Conference
Copyright © 2013, American Society for Engineering Education

18. R. Unnikrishnan and Ricardo Lopez, "Learning Communities Improve Retention in Engineering and Computer Science," *Proceedings of the ASEE/PSW Conference*, San Diego, CA, March 16-19, 2009.
19. R. Unnikrishnan and Gina Garcia, "Enhancing Engineering and Computer Science Education for a Diverse Community," *Proceedings of the Fifth International Latin American and Caribbean Conference for Engineering and Technology (LACCEI'2007)*, 29 May–1 June 2007, Tampico, México.
20. Sullivan, E. and Trotter E. 2011. CSUF report on findings from campus leading indicators analysis.
21. Taningco, M. T. V., Mathew, A. B., & Pachon, H. P. 2008. STEM professions: Opportunities and challenges for Latinos in STEM. University of Southern California: Tomás Policy Institute.
22. Tinto, V. 1993. *Leaving College: Rethinking the Causes and Cures of Student Attrition*, 2nd edition. Chicago: University of Chicago Press.
23. Walpole MB, Zimmerman H, et al. 2008. Bridge to success: Insight into summer bridge program students' college transition. *J of the First Year Experience and Students in Transition*. 20(1):11–30.
24. U.S. Census Bureau. 2011. Resident population by race, Hispanic origin, and age.
25. U.S. Department of Education. 2010c and 2010d. Digest of Education Statistics – National Center for Education. nces.ed.gov/Programs/digest
26. Bjorklund, S.A., Parente, J.M., and Sathianathan, D. (2000). Effects of Faculty Interaction and Feedback on Gains in Student Skills. *Journal of Engineering Education*.
27. Goodsell, A., Maher, M., Tinto, V., and Smith, B.L., & MacGregor, J. (1992). *Collaborative learning: A sourcebook for higher education*. University Park: The National Center on Postsecondary Teaching, Learning, and Assessment.
28. Lundberg, C. A., and Schreiner, L. A. (2004). Quality and frequency of faculty–student interaction as predictors of learning: An analysis by student race/ethnicity. *Journal of College Student Development*, 45(5), 549–565.
29. Pascarella, E. T., and Terenzini, P. T. (2005). *How college affects students (Vol. 2): A third decade of Research*. CA: San Francisco Jossey-Bass.
30. Smart, J. C., Feldman, K. A., & Ethington, C. A. (2000). *Academic disciplines: Holland's theory and the study of college students and faculty*. Nashville: Vanderbilt University Press.
31. Tinto, V. (1982). The Limits of Theory and Practice in Student Attrition. *J. of Higher Education*. 53: 687-700.
32. Tinto, V. (2006). Research and Practice of Student Retention: What Next? *Journal of College Student Retention*, 8(1) 1-19.
33. Tinto, V. (2008). *Creating Conditions for Student Success*. Presented at University of Maine System.
34. Umbach, P.D., and Wawrzynski, M.R. (2005). FACULTY DO MATTER: The Role of College Faculty in Student Learning and Engagement. *Research in Higher Education*, 46(2).
35. Vygotsky, L. (1978). Interaction between Learning and Development (pp. 79-91). *Mind in Society*. Cambridge, MA: Harvard University Press
36. Walen, D., Saunders, K., and Shelley, M. (2010). LEVERAGING WHAT WE KNOW TO ENHANCE SHORT-TERM AND LONG-TERM RETENTION OF UNIVERSITY STUDENTS. *Journal of College Student Retention*, 11(3) 407-430.
37. President's Council of Advisors on Science and Technology (PCAST) report 2012 "Engage to Excel: Producing One Million Additional College Graduates With Degrees In STEM." http://www.whitehouse.gov/sites/default/files/microsites/ostp/pcast-engage-to-excel-final_feb.pdf
38. Institutional Research and Analytical Studies, California State University Fullerton, [unpublished data tables by Sullivan and Moon], <http://www.fullerton.edu/analyticalstudies/>
39. Kuh, G. 2008. *High Impact Educational Practices: What they are, who has access to them, and why they matter*. Association of American Colleges and Universities.
40. Moon, S., Hershey, J., & Sullivan, E., Bonsangue, M., Walker, S., & Filowitz, M. (2011). The Effectiveness of Supplemental Instruction Closing the Gap between URM & Non-URM Students in STEM Courses. *Paper presented at the CAIR (California Association for Institutional Research) Conference*, Nov 8 – Nov10, 2011, Sonoma, California.

Academic Analysis of an Android Based Student Project: Remote Medical Monitoring Station

Danyang Li, Qiao Zhen, Albert Gordon, Bhaskar Raj Sinha, Marcos Turquetti, Mohammad N. Amin
National University, San Diego, California

Abstract

First responders provide urgent care to patients in medical emergency. Such care must be initiated as quickly as possible in order to maximize the survivability of the patient. Since first aid procedures are often needed, early information on the patient's overall condition is an asset to the responders. Advances in wireless communication data collection have occurred on several fronts. In the healthcare field, it is almost standard now to use sensors of many types to collect information and to send it to a patient's phone. Multiple instances of such data collection can occur via the Bluetooth standard, the Healthcare Device Profile (HDP), etc. This project utilizes some of these sensors, together with Bluetooth communication standards, to create a remote medical monitoring station. A new mobile app was developed using the Android platform to collect, display, and store biometric data on a mobile phone, and integrate it with WiFi and cellular networks. Relevant information is forwarded to a relational database developed for storage, or can also be directed to the first responders in case of emergency. Elderly patients, who are at home, or perhaps live far away from their physicians, are at risk when it comes to their health. This system will enable them and their physicians a daily look at their vital signs without having to leave their home or office. A prototype of this system was designed, developed, and tested by students under the guidance of faculty members. This project was analyzed on how it fulfilled the program objectives. Students made a formal presentation to the Faculty Judging Panel for official approval of this capstone project and the project was approved for the degree requirement. The final report and the presentation were graded and it was ensured that they covered and reinforced the academic objectives and met the Program Learning Outcomes (PLOs).

Introduction

The Master of Science in Wireless Communications (MSWC) program at National University (NU) is a professional degree that integrates communication techniques, problem solving strategies, simulation skills and mathematical foundations with hands-on training required to solve real world problems in telecommunications²⁹. The program is designed for professionals and managers to facilitate the learning and application of skills in the field of wireless communications, and uses a distinctive and challenging curriculum that emphasizes multidisciplinary knowledge. The program integrates theory through applications and design concepts. Classes combine lectures, case and hands-on studies, individual and team projects, research papers and participant presentations. With NU's MSWC program, faculty, students, and employers are assured that the graduates are proficient in analytical, technical and critical thinking skills. They have a sense of professionalism that is instilled with a strong set of values

essential for success in the wireless communications field. This program reflects current and future industry needs, and graduates from the MSWC program are trained and prepared to assume a leadership role in the field. The MSWC program prepares students to achieve professional success in both theoretical and practical aspects of communication fields. Graduates are equipped to seek employment in research organizations, computer centers, or wireless communications businesses and enterprises. This program also prepares students for further education in wireless communications enabling graduates to pursue doctoral studies, if they choose to do so. It is assumed that candidates seeking admission to the program possess a baccalaureate degree in engineering, engineering technology, or physical/computational science from an accredited university. Projects have been undertaken at NU that read a single channel of sensor data using Bluetooth into a phone and transferring that information to the web. These are centered on providing a system for reading vital signs of patients in a remote location. This capstone project, named Remote Medical Monitoring Station (RMMS), enhances the idea under an entirely different category by adding information such as GPS location, name, age, and sex, together with the ability to read multiple sensors simultaneously, having the database make decisions as to whether readings are in or out of expected parameters, and having the data create separate files for each user on the web server. First responders would find this product very useful, and hence, the focus is towards utilizing this product as an emergency medical device.

Literature review suggests some past work in this area. Heart Rate App¹, recently renamed to Instant Heart Rate, is a tool to monitor a person's heart rate, but the information obtained is kept locally on the phone. Health-Manager Pro² keeps track of body movements throughout the day and makes decisions, but the information obtained is kept locally as well. There are also quite a few apps that store a person's medical needs and history, such as ICE (In Case of Emergency)³ and also ones that explore pharmacology prescription conflicts. Emergency Backpack⁴ gives GPS information, but that is the extent of the data that is processed after offering some stored "survival tips". Skyscape, Medscape, Epocrates RX, and MedCalc^{5,6,7,8} offer calculators, medical news alerts, and practice guidelines but provide no hard data about the current condition of the patient. This project, RMMS, provides a reasonable path to opportunity based upon its functions and how it can transmit information from people who have a need for help to people who can provide it. In the case of its use in a mass emergency, the new ability to pinpoint the victims who are in the worst conditions and who should be helped first is a way that lives could be saved, and RMMS provides a path to opportunity from that perspective.

This paper is an analysis of this capstone project (RMMS) and determines how it addresses the objective of this program and individual Program Learning Outcomes (PLOs), here at NU.

The Project: Remote Medical Monitoring System (RMMS)

This device is designed to read vital signs from sensors placed on a subject's body. There are a number of such devices available that collect this kind of information and send it to a receiver using Bluetooth. This project utilizes two such devices, a device for taking blood pressure (A & D Model UA-767 Plus BT-G) shown in Figure 1, and a device for measuring the temperature of the body (FORA IR20b Ear Thermometer with Bluetooth), shown in Figure 2.



Figure 1: A & D Model UA-767 Plus BT-G

These devices, together with the Android phone, create a piconet within the local area up to about 30 feet using Bluetooth connectivity. The newly emerging Health Device Protocol (HDP), an open standard agreed-upon by manufacturers, makes it possible to stack multiple, formerly incompatible devices that used the older serial socketing standard. The HDP resides on the core specification for Bluetooth. The Android phone application is designed to process data from the three sensors to which it is paired: the thermometer, the blood pressure monitor, and the pulse rate indicator.



Figure 2: FORA IR20b Ear Thermometer with Bluetooth

The key component in the design is the Android application within the phone. This application functions to display the collected information from the sensors and to provide decision-making capabilities such as whether the data parameters measured are far enough removed from normal range to warrant further attention (green coloring of the data on the display if the readings appear normal and red coloring if the data appears to be either above or below the range that is considered normal). Another important feature of this Android application is to integrate the information from the sensors with GPS location, time and date, and keyboard information where the patient's name, age, and sex is entered. The application sends all of the information through the cellular system link using SMS to an internet server having a database where a physician or other health professionals can access the information. This internet web page displays on a single screen the patient's name entered from the keyboard, the GPS location where the patient is

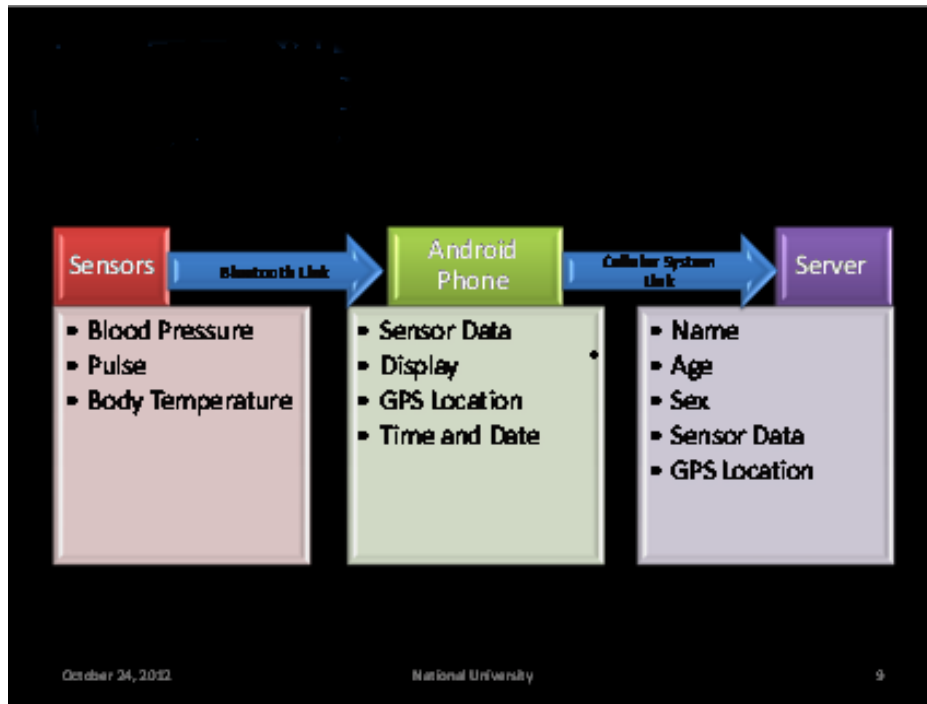

Figure 4: System Functional View: Sensors, Android Phone and the Server.

An implementation challenge was to solve the problem of integration of the data coming from the Bluetooth devices, the computer keyboard (for entry of patient's name, age, and sex), the GPS device on the phone, and the day/date of the real-time clock. The incoming Bluetooth data arrives at different times. The implementation in this regard is to buffer the information, holding it until all of the data can enter the database with the current time stamp and processed as a single unit. Other technical objectives relate to the Android phone's database having the ability to make decisions on the data in addition to the keyboard and GPS integration. For example, if the vital signs data arriving at the Android phone falls outside certain range for a patient's age and sex, the data is flagged by changing color. Another technical objective involves setting up a server that holds information accessible to EMT personnel in transit to an emergency or physicians who are interested in caring for a patient who are homebound, monitoring their vital signs on a daily basis. This database reads the date/time stamp sent from the phone along with the data, and when the data and time change (indicating new data), the server self-saves into the patient's file the prior data, and the new data is displayed, along with the GPS information, the time/date stamp, and the patient's name, age, and sex. In other words, the server displays much the same information as the phone displays at the patient's site at approximately the same time²². Another technical feature includes the successful implementation of data conversion from Java strings into data suitable for HTML/XMS data, such as using SMS. Also, the Eclipse IDE, while useful as an emulator for most applications, cannot emulate a Bluetooth link. Such development must be done completely on a suitable phone and a technical objective is to provide such an environment. The project website page is shown in Figure 5. This page has links leading to medical entries test tables. The website architecture schematic in Figure 6 shows the main page and the subpages.

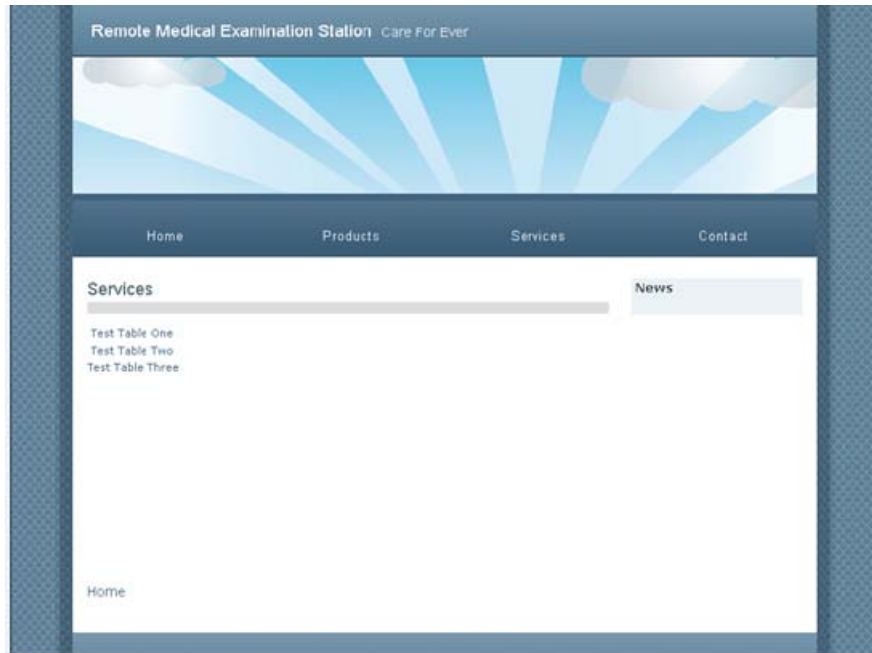

Figure 5: Project Website

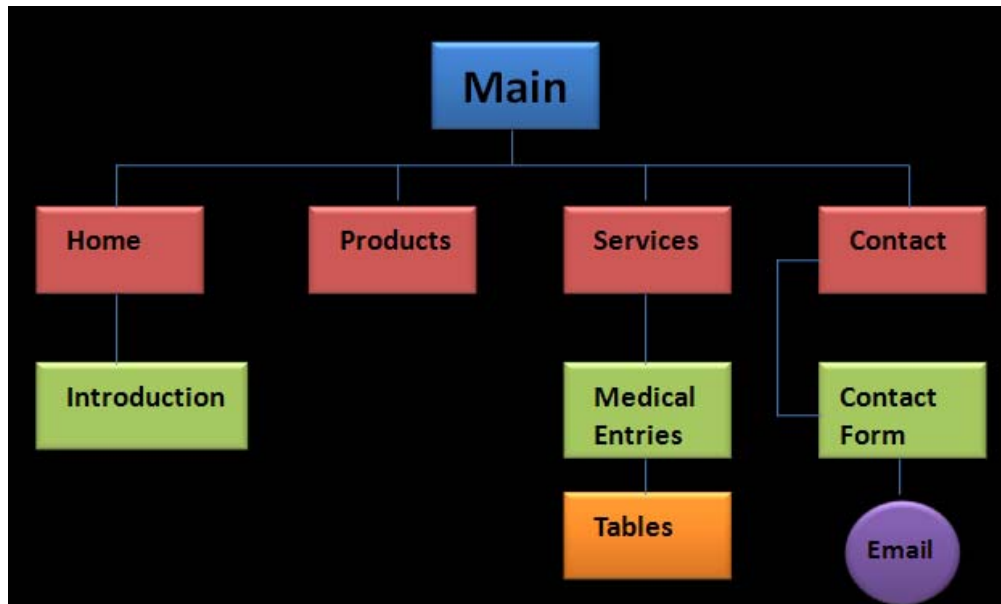

Figure 6: Website Architecture

The main page has four subpages: Home, Products, Services, and Contact. The Home page gives the general introduction to this project. On the Products page, the user can find which kind of medical devices are used for this project. The Services page shows the information table access page to reach the “Medical Entries”, and the last page is Contact which provides the contact information of builders, which allows users to email builders quickly and easily. The Contact page is shown below in Figure 7.

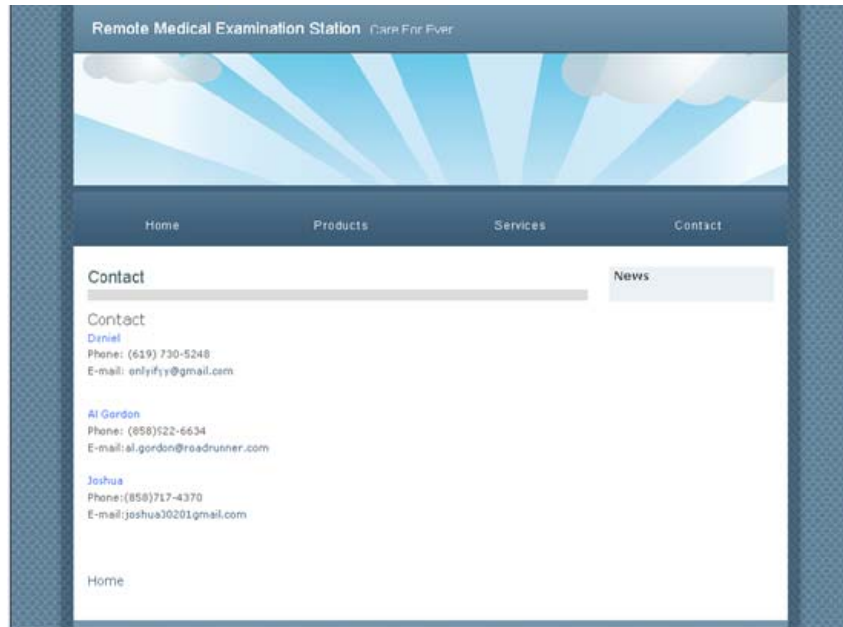

Figure 7: The Contact Page

In addition to learning how to create HTML, CSS and possibly a server side language like PHP, it is important to use the proper tools to create the website, upload them and maintain them. The first one is Testing server. Since this project not only created HTML/Javascript/CSS files but also needed to use server side languages such as PHP and databases, it was necessary to download a server which was installed on the local machine. Some subpages on the website are dynamic pages, so there is also code from a programming language like PHP which the servers turns into HTML before serving the page to the user. A tool was found which allowed creation and editing of pages. In order to test the website properly, it was necessary to see how it looks on all the major different browsers. FTP client helped upload files to the server (assuming an existing local web host). Some web tools were used to develop this project: XAMPP was the test server; Notepad++ was the webpage editor; GIMP was the graphics editor; Firefox, Chrome, Internet Explorer, and Safari were the test browsers; and FileZilla was the TP client. 000webhost was the web host on the Internet. There are four main languages used for web programming. PHP is used for developing the dynamic pages; HTML is the basic language when designing the web page. Cascading Style Sheets (CSS) defines how to display HTML elements and these were added to HTML 4.0. External Style Sheets are stored in CSS files. Finally, SQL is a standard language for accessing databases.

Recommendations for Future Research

There is a concern that sending a person's name along with the medical data over the internet might violate HIPA (Health Information Privacy Act) requirements. Therefore further work needs to be done with a patient's code number in the SMS data packet instead of the name. To make this product more marketable, another area of research is to port this onto different platforms, besides the cellular phones, that are more robust and are unlikely to be affected by earthquakes, fire, or other similar emergencies. An example of such an alternate platform might be the satellite phones that communicate with satellite repeaters that travel far above the area

affected by such a disaster and would most likely be intact during such an emergency. Another recommendation for future work is to do a Google maps directly from the coordinates presented on the server that locates a victim. This feature might include having the coordinates appearing as hyperlinks on the webserver, and clicking on the hyperlink opens up a new screen with the map locating that victim instead of using the raw coordinates for location purposes. Finally, future work needs to be undertaken to not mix HDP (Health Device Profile) and SPP (Serial Port Profile) in the same application. This project was looking for a singular device (one monitor) that was Continua certified and that stood alone as a second, singular monitor. The research discovered that all the other HDP devices not only contained several monitors but were also quite expensive. In the future, a stand-alone SPP device could be used instead of an HDP device. The recommendation is that HDP and SPP profiles not be mixed in the same application. As a practical matter they could be mixed using a time multiplexing polling loop that is not too large and that does not spend a lot of time during the loop away from either one or the other device to be managed. During testing of the app, it was determined that approximately 30% of the time one of the devices failed to get read into the application. Therefore, it is recommended not to mix the two profiles in a code rewrite in order to address this reliability issue.

Academic Analysis of the Capstone Project

The NU MSWC program is a professional curriculum developed in 2004. This was based on modern digital communication techniques and it facilitates students in wireless communications to learn problem solving techniques, advanced system design, and simulation. The mission of this program is reflected in the Program Learning Outcomes (PLOs) as follows:

1. Evaluate wireless networking, protocols, architectures, and standards to the development and design of wireless communication systems.
2. Evaluate and select the appropriate kinds of coding and decoding schemes for constructing, detecting and filtering wireless communications signals.
3. Build security into wireless communications systems and contrast ethical and legal issues in the global telecommunications industry.
4. Plan, integrate and implement multiple types of Second (2G) and Third Generation (3G) wireless networks.
5. Create strategic analysis software and tools to develop wireless, networks and service plans.
6. Develop simulation models of the radio components of wireless systems using MATLAB, SIMULINK and its communication tools.
7. Evaluate and forecast economic impact of continually advancing technologies on wireless service, equipment, application providers, and consumers.
8. Conduct research into a specific wireless communication topic, including finding and integrating relevant research results of others.
9. Demonstrate critical thinking and ability to analyze and synthesize wireless communications concepts, project management principles, and ethical standards.

In this program, students have the opportunity to learn theory, principles, and hands-on activities in the field through twelve courses. At end of the program, all students are required to take two project classes (Capstone) which allow them to apply technology and solution theories in various new and innovative applications. PLOs are achieved in the two project classes: WCM611A and

WCM611B. Duration for completing this project is three months. Students are encouraged to work as a team to gain valuable experience needed by most industries in the 21st Century. In the first month, students form teams (2-4 students per team), select research topics, conduct literature search, analyze critical aspects, and plan to reach a viable solution. In the second and third months, students perform the necessary tests/experiments, data collections, build prototypes, prepare project reports, make formal presentations, and prototype demonstration. All MSWC projects are subject to assessment by a Faculty Judging Panel (two faculty members and two industry professionals) using a “Assessment of Learning Outcomes” shown in Figure 8, that contains all the assessment criteria.

Validation of Graduate Program and Success

In this ‘Remote Medical Monitoring Station (RMMS)’ Capstone project (Group#2), an extensive literature search was conducted by the students in order to identify the critical user requirements, and identify a viable and cost-effective solution. Students completed the project in three months. During the first month, three students formed a team based on their common interest, elected a team leader, assigned each member tasks and responsibilities, and collected the required materials and equipment/resources. During the next two months, students were engaged in accomplishing the following: 1) design and development of different software using the appropriate tools and platforms, 2) integration of hardware and software for building a prototype, 3) testing and evaluation of the prototype, 4) collection of data and information, 5) organizing ideas and thoughts, and 6) preparing for the presentation and the written project report. At the end of the third month, students submitted their project report (first draft) to the Faculty Judging Panel of five members (two internal and three external) for review and made a formal presentation followed by a successful demonstration.

After observation of this project presentation and careful review of the written report Panel Members submitted their evaluation reports using a set of rubrics to the MSWC Program Lead Faculty. The summary of these average evaluations for this project is displayed in the Figure 8. All evaluations and comments received from the Faculty Judging Panel indicate that students did very well in the project, gained appropriate graduate level knowledge and practical experience in the field. The findings of this study confirm that student learning is aligned with the program missions and program learning outcomes.

NATIONAL UNIVERSITY					
School of Engineering, Technology and Media					
Assessment of Learning Outcomes by Faculty Judging Panel					
Academic Program: Master of Science in Wireless Communication					
Research Project I and II [WCM611A and WCM611B]					
<i>Directions: Based on each project team's presentation and submitted materials, please indicate - for each measurable outcome included in column 2 - a number of assessment points (up to max. indicated in column 2) and a percentage of students in the team that demonstrated respective competency. For example, if, for the team #1, the measurable outcome titled "Communication Tools" was assigned 22 out of 25 points and the percentage of students in this team who demonstrated respective competency was 80%, then the number 22/25 should be written in the respective (in this example, the first) row for the Team 1 column.</i>					
<i>Use the blank areas to make notes of questions you wish to ask at the end of the team presentation.</i>					

PLO	Program Learning Outcomes	Assessment Criteria and Measurable Outcomes	TEAM GRADE [25 MAX]			
			1	2	3	4
1	Evaluate wireless networking, protocols, architectures, and standards to the development and design of wireless communication systems.	Report		24		
		Prototype Demonstration		23		
		Presentation		24		
2	Evaluate and select the appropriate kinds of coding and decoding schemes for constructing, detecting and filtering wireless communications signals.	Report		25		
		Prototype Demonstration		22		
		Presentation		24		
3	Build security into wireless communications systems and contrast ethical and legal issues in the global telecommunications industry.	Report		23		
		Prototype Demonstration		21		
		Presentation		22		
4	Plan, integrate and implement multiple types of Second (2G) and Third Generation (3G) wireless networks.	Report		24		
		Prototype Demonstration		23		
		Presentation		23		
5	Create strategic analysis software and tools to develop wireless, networks and service plans.	Report		25		
		Prototype Demonstration		24		
		Presentation		24		

6	Develop simulation models of the radio components of wireless systems using MATLAB, SIMULINK and its communication tools.	Report		24		
		Prototype Demonstration		23		
		Presentation		22		
7	Evaluate and forecast economic impact of continually advancing technologies on wireless service, equipment, application providers, and consumers.	Report		21		
		Prototype Demonstration		24		
		Presentation		23		
8	Conduct research into a specific wireless communication topic, including finding and integrating relevant research results of others.	Report		22		
		Prototype Demonstration		25		
		Presentation		24		
9	Demonstrate critical thinking and ability to analyze and synthesize wireless communications concepts, project management principles, and ethical standards.	Report		22		
		Prototype Demonstration		23		
		Presentation		24		

Figure 8: PLOs and Project Grading for Team 2 [RMMS]

Conclusions

A prototype of the RMMS system was designed, developed, and tested by students under the guidance of faculty members. Goals with regards to this project and meeting the program PLOs were accomplished, and the project was successfully demonstrated at a gathering of National University personnel, including faculty. A random person from the audience was selected during the demonstration, sensors were strapped on the subject, and vital signs read the were read on, not only the cellphone, but also sent the person's vital signs, name, age, sex and location successfully via the internet to one line of our monitoring program on the webserver. Based on the above successful demonstration of the project prototype, it is suggested that this application could be made marketable in at least two general areas: (1) as an assistance to first responders in an emergency that requires critical care to a large number of patients being served by a limited number of medical personnel, and (2) as a device to be sold to doctors and/or patients who need to be monitored often but who live in a remote area not having means of transportation to a medical professional for the purpose of being examined. In the latter case, such monitoring would not replace assistance by a professional but only enhance the care being offered by being able to more closely watch a patient. This project was analyzed on how it fulfilled the program objectives. Students made a formal presentation to the Faculty Judging Panel for official approval of this capstone project and the project was approved for the degree requirement. The final report and the presentation were graded. This paper demonstrates an academic analysis of this capstone project and determines how it reinforced the academic objectives and addresses the objective of this program and individual Program Learning Outcomes (PLOs), here at NU.

References

1. App Brain Online. *App Brain Report: Instant Heart Rate*. (2012). July 28, 2012 from <http://www.appbrain.com/app/instant-heart-rate/si.modula.android.instantheartrate>
2. Androlib Online. *Androlib Report: Healthmanager Pro*. (2012). July 28, 2012 from <http://www.androlib.com/android.application.jp-ievolution-healthmanager-pro-niiE.aspx>
3. Google Play Online. *Google Play Report: In Case of Emergency (ICE)*. (2012). July 28, 2012 from <https://play.google.com/store/apps/details?id=com.appventive.ice>
4. Latest Android Apps Online. *Emergency Backpack App Review*. (2012). July 29, 2012 from <http://latestandroidapps.net/apps/tools/emergency-backpack/>
5. Skyscape Online. *Free Skyscape Medical Resource App*. (2012). July 29, 2012 from <https://www.skyscape.com/index/home.aspx>
6. Medscape Mobile Online. *Medscape Mobile Application*. (2012). July 29, 2012 from <http://www.medscape.com/public/mobileapp>
7. Epocrates Online. *Epocrates Medical Application for Android*. (2012). July 29, 2012 from <http://www.epocrates.com/mobile/android>
8. AppsZoom Online. *Android Zoom Report: MedCalc*. (2012). July 30, 2012 from http://www.androidzoom.com/android_applications/medcalc
9. Wikipedia Online. *Android (operating system)*. (2011). Aug 2, 2012 from [http://en.wikipedia.org/wiki/Android_\(operating_system\)](http://en.wikipedia.org/wiki/Android_(operating_system))

10. PR Web Online. *Blood-pressure Monitor*. (2012). Aug 2, 2012 from http://www.prweb.com/releases/blood_pressure_monitoring/BP_measurement_instrument/prweb4720184.htm
11. WebMD Online. *Body Temperature Thermometer*. (2011). July 20, 2012 from <http://firstaid.webmd.com/body-temperature>
12. Kickstarter Online. *Pulse Sensor: An Open Source Heart-rate Sensor that Rocks*. (2011). Retrieved July 27, 2012 from <http://www.kickstarter.com/projects/1342192419/pulse-sensor-an-open-source-heart-rate-sensor-that>
13. App Brain Online. *Number of Android Applications*. (2012). July 27, 2012 from <http://www.appbrain.com/stats/number-of-android-apps>
14. Youtube Online. *Programming for Android, Part 1, Installing Everything You Need*. (2012). July 25, 2012 from http://www.youtube.com/watch?v=z_vCORLryuo&feature=related
15. Rural Assistance Center Online. *Emergency Medical Services*. (2012). August 1, 2012 from <http://www.raconline.org/topics/ems/>
16. Hubbard, John R. (2004). *Programming with Java*, 2nd edition. Schaum's Outline Series. McGraw-Hill. 303-311.
17. Zakhour, Hommel, Royal, Rabinovitch, Risser, and Hoeber. (2006). *The Java Tutorial*, 4th edition. Sun Microsystems. 261-276.
18. Jackson, Wallace. (2011). *Android Apps for Absolute Beginners*. Apress Publishing. 147-166.
19. Android Medical Apps. *Android Medical Apps*. (2012). Retrieved July 22, 2012 from Google
20. Goodman, John. (2012). *Medicine by Remote Control*. National Center for Policy Analysis. <http://healthblog.npcpa.org/medicine-by-remote-control/>
21. Huang, Randolph. (2007). *Bluetooth Essentials for Programmers*. Cambridge University Press. 41-50
22. Mercer, David. (2001). *Schaum's Outline of HTML*. McGraw Hill. 212-216
23. Mills, Elanor. (October 16, 2011). *Report: Android App Market Growing Faster Than iPhone Apps*". *CNET Reviews*.
24. Tasooji, Matthew. (3/17/2012). Lecture on new areas of technology, WCM607, Day7. National University.
25. Conversations with proclaimed Bluetooth/Android programming "gurus". 7/2012–9/202
26. Le Bodic, G. (2003, January). *Mobile Messaging Technologies and Services: SMS, EMS and MMS*, John Wiley & Sons. West Sussex, England
27. Stichbury, J. (2004). *Symbian OS Explained: Effective C++ Programming for Smartphones*. John Wiley & Sons, Hoboken, NJ.
28. Barker, R. & Edwards, L. (2004, July). *Getting Started With C++ SDKs and Symbian Development*. Addison-Wesley Professionals. Indianapolis, IN. Retrieved August 20, 2009 from <http://www.informit.com/articles/article.aspx?p=176459&seqNum=3>
29. Amin, M. (2010). *Master of Science in Wireless Communications*. National University. San Diego, CA, Retrieved December 26, 2010 from <http://www.nu.edu/OurPrograms/SchoolOfEngineeringAndTechnology/AppliedEngineering/Programs/720-816.html>
30. Jenefsky, C., Bresciani, M., Buckley, L., Fairris, D. & Kasimatis, M. (2009, September). WASC Resource Guide for "Good Practices" in Academic Program Review. *Western Association of Schools and Colleges*. Burlingame, CA. Retrieved December 3, 2010 from http://www.wascenior.org/findit/files/forms/WASC_Program_Review_Resource_Guide_Sept_2009.pdf
31. Wikipedia Online. (2012). *Location-based Service*". October 12, 2012 from http://en.wikipedia.org/wiki/Location-based_service
32. Wikipedia Online. (2012). *Short Message Service*. October 17, 2012 from http://en.wikipedia.org/wiki/Short_Message_Service
33. Wikipedia Online. (2011). *Global Positioning System*. October 12, 2012 from
34. http://en.wikipedia.org/wiki/Global_Positioning_System

Authors' Biographies

Danyang Li

Student, MS Wireless Communications Program, School of Engineering and Technology, National University, San Diego, California, onlyifyy@gmail.com
Major research interests: Wireless communications, sensors

Qiao Zhen

Student, MS Wireless Communications Program, School of Engineering and Technology, National University, San Diego, California, joshua002@126.com
Major research interests: Wireless communications, sensors

Albert Gordon

Student, MS Wireless Communications Program, School of Engineering and Technology, National University, San Diego, California, al.gordon@roadrunner.com
Major research interests: Wireless communications, sensors

Bhaskar Raj Sinha, Ph.D.

Professor and Lead for the BS Information Technology Management Program, School of Engineering and Technology, National University, San Diego, California, bsinha@nu.edu, Tel: (858)309-3431, Fax: (858)309-3419
Major research interests: Computation, digital systems, database, software engineering.

Marcos Turquetti, Ph.D.

Adjunct Faculty, MS Wireless Communications Program, School of Engineering and Technology, National University, San Diego, California, Marcos.Turquetti@natuniv.edu
Major research interests: Wireless communications, database, sensors

Mohammad N. Amin, Ph.D.

Professor and Lead for the MS Wireless Communications Program, School of Engineering and Technology, National University, San Diego, California, mamin@nu.edu, Tel: (858)309-3422, Fax: (858)309-3419
Major research interests: Wireless communications, database, sensors

Bringing Design and Construction into Elementary School Classrooms with Sandcastles

**Pamalee Brady, Ph.D, PE
James Guthrie, SE
California State Polytechnic University**

Abstract

The design and construction professions face a continuing need to attract talented and trained individuals. A promising approach is to introduce these professions to students in elementary school classrooms. The Sandcastle Project is a collaborative effort that will bring students and faculty in the Cal Poly College of Architecture & Environmental Design (CAED) and the School of Education into local elementary school classrooms. The CAED includes departments in Architectural Engineering, Architecture, City & Regional Planning, Construction Management and Landscape Architecture and can provide students and faculty who are competent in all areas of building design and construction. Students in the School of Education are the optimal means of introducing technical concepts and practices for the present and future education of elementary school students.

The goals of the Sandcastle Project are to stimulate elementary school students' creativity and an interest in building design, engineering and construction and to use real world examples of math and science to reinforce standard curricula. Teacher candidates from the School of Education and students from CAED will join elementary school students initially in the classroom and later in an afterschool program. Exercises will give the elementary school students the experience of acting as the architect, engineer and contractor. The culmination of the project will be a sandcastle competition. Students will design and plan the construction of their sandcastles and will build them at a local beach on a Saturday morning. The paper will describe the goals of the Sandcastle Project, the method of its implementation, assessment methods and future steps.

Introduction

Studies by the National Academy of Engineering¹ and President's Council of Advisors on Science and Technology (PCAST)² among others have identified the need to enhance the pathways to careers in science, technology, engineering and math to attract an abundant, diverse and proficient workforce. This will involve both improving our educational content and conveying the importance, value and satisfaction that can be achieved in such careers. As the PCAST report emphasizes improving STEM education requires we "focus on preparation and inspiration." This is a task best accomplished collaboratively by educators, industry and government each bringing resources and skills to change the decline of interest and ability in students in science, technology, engineering and math.

As Ellis, Jackson and Wynn³ have proposed introducing young students to engineers and connecting subject matter to relevant applications in engineering can support "imprinting" engineering as a career pathway. Increasing student understanding of engineering in relation to the world around them can minimize misperceptions, and highlight the many ways engineering

improves the quality of our lives. Engineering can motivate the need to master the principles and concepts presented in science and math and make them more accessible.

Background

The authors' outreach work has explored a number of different methods for informing and engaging K-12 students in engineering. These have included using story and hands-on experiments in elementary grades⁴, as well as more formal lessons to high school students including computer simulations of structural behavior. This outreach program was stimulated by the ideal location and situation of California Polytechnic State University in the San Luis Obispo community and was modeled, in part, on a similar outreach program in the San Francisco Bay Area. Leap Arts in Education⁵ sponsors an annual sandcastle contest which joins Bay Area art and design professionals with elementary school children in building sandcastles of the students' design. The beaches surrounding San Luis Obispo, multiple school districts with diverse populations, a polytechnic university well known for its architecture and engineering programs as well as its teacher credential program and strong links between the university and the local professional community provide the optimal foundation for developing a similar contest on the Central Coast.

The program is supported by a small university grant which encourages collaboration across colleges as well as among departments within colleges. We have chosen to work with faculty in the School of Education who are teaching and mentoring candidates in the teacher credential program. The Sandcastle Project is envisioned in four parts: engineering content enrichment for teacher candidates, classroom lesson for grades 4 through 6 to introduce the design process and the professions involved in accomplishing a construction project, an after-school program for interested 4th – 6th graders to undertake the sandcastle planning and design, and finally construction of the sandcastles at a local beach. The design of the program incorporates the six guidelines for improving K-12 engineering education and outreach presented by Douglas et al.⁶ It employs hands-on learning, takes an interdisciplinary approach, addresses current math and science curriculum standards, engages teachers in the development of the lessons and enriches their understanding of content, provides mentors and role models who represent the diversity sought in the professions, and makes use of partnerships between multiple stakeholders.

Goals

The Sandcastle Project will introduce the design and construction professions (architects, engineers, contractors) into local elementary school classrooms with overall goals that are two-fold. One goal is to use the design and construction practices to provide elementary school teachers with real world examples of math and science to reinforce standard curricula. Examples include the calculation of slopes, areas and volumes, and applying scaling principles.

A second goal is to introduce the design and construction professions to elementary school students with the hope that this will ignite an interest in some of the students that may lead to rewarding careers. Beyond that it is hoped for all of the students an introduction to the design and construction professions will: 1) introduce them to the design process as a means of problem solving, 2) teach them to think about space and imagine how they can affect the built

environment in which they live and 3) reinforce the importance of teamwork and collaboration by describing how they are used in the building design and construction process.

The approach of the Sandcastle Project is to work jointly with teacher candidates and faculty from the School of Education and students and faculty from the CAED. This collaboration will employ the knowledge and expertise of both colleges. CAED faculty will use their knowledge of design and construction to educate the teacher candidates about these professions and to help develop content and lesson plans. The teacher candidates are already embedded in local elementary school classrooms and so are in an ideal position to lead the elementary school classroom instruction. They will be supported in the classrooms by the CAED students and observed by CAED and School of Education faculty. This approach appropriately employs the expertise of the students and faculty from both colleges. It also encourages the professional development of the students of both colleges. The School of Education's teacher candidates will be introduced to technical concepts and practices of the design and construction professions and also to real world examples of math and science they may use to reinforce standard curricula. CAED students will develop a fuller understanding about the place of these professions in the world.

Implementation Plan

The implementation of the Sandcastle Project will occur in four phases: teacher candidate training, classroom session, after-school program and the sandcastle competition.

Teacher Candidate Training. The teacher candidates now have little or no knowledge of the design and construction industry or professions. In a survey of 39.1% of teachers most teachers surveyed said that they and their students would benefit from increased engineering exposure in their classrooms.⁶ CAED faculty will therefore provide them an introduction to that industry. The CAED will also prepare proposed learning outcomes, content and lesson plans for the teacher candidates to use in the next phases. The CAED students will join the teacher candidates in the training sessions. The training sessions will be a two-way process. Although the CAED faculty and students will describe the work of the building design and construction professionals, the teacher candidate students will share their knowledge of work in the classroom.

Classroom Session. The classroom session is envisioned to be a 50 minute long module that will: 1) introduce the elementary school students to the design and construction professions, 2) provide an activity in which the elementary school students can practice these roles and 3) encourage students to continue in the after-school program and sandcastle competition. The basis for the session is founded on work conducted by senior architectural engineering students at California Polytechnic State University to introduce elementary students to professions in design, engineering and construction of buildings.⁷ The activity is to design and construct a bridge structure that meets a client's wants and needs. The elementary school students will be formed into teams of 3 or 4 students each and these teams will be formed into groups of three teams each. The three teams in each group will sequentially take on the roles of client, designer and contractor. The design of the activity follows the several of the guidelines for improving K-12 engineering education and outreach that are documented by Douglas et al⁶. The lesson

involves hands-on learning and takes an interdisciplinary approach by incorporating writing, drawing and construction and presents the perspectives of different disciplinary role players.

Each team will first play the role of the client. They will describe the goals of the bridge structure. How long must the bridge be? What appearance is desired? The teams will then pass on the descriptions of the client's requirements to another team.

The next role played by the teams will be that of the designer (engineer) that will translate the client's needs and wants into drawings from which the contractor will work. The drawings should be a translation of the client's words into a design. The drawings might include a plan of the structure and side views. The teams will then pass on the drawings to another team who will be the contractor.

In the role of the contractor the teams will determine the types and quantities of materials needed to build the bridge structure. This will be an exercise in planning and the use of math concepts such as area and volume. The teams will build models of the structures from a kit of parts, Figures 1 and 2.



Figure 1. Completed "suspension" bridge.



Figure 2. Loaded "beam" bridge.

The teams and groups will compare what they have accomplished. Did the designs reflect what the clients requested? Did the construction reflect the drawings? It is hoped that the elementary school students will be encouraged to enroll in the after-school program.

After-School Program. The after-school program is envisioned to be two 90 minute long two sessions that will lead to the sandcastle competition. The after-school sessions will have two components, additional lectures and activities that describe the design and construction professions and industry. This will be an opportunity to present simple engineering concepts and supplement their math and science curriculum. The sessions will focus on understanding steps in the design process, a key feature of Massachusetts Department of Education⁸ engineering standards for grades 3-5.

The second component will be to prepare for the sandcastle competition. Using a theme presented to them, the elementary school students will prepare a design for their sandcastle.

They will have to consider what forms are feasible, the tools they will need, what they can build given the size of the team and the time allotted. This design and planning are of course reflections of activities undertaken in the profession.

Competition. The competition is envisioned to take place on a Saturday at a local beach attended by the student teams, parents, the candidate teachers and students and faculty from the School of Education and CAED. Judges from the colleges and local firms will assist with prizes and lunch for all. It should be a fun and memorable experience.

The implementation plan described above incorporates the goals of the project. It uses the design and construction practices to provide elementary school teachers with real world examples of math and science such as the calculation of slopes, scales, areas and volumes. It also introduces the elementary school students to the design and construction professions to elementary school students with the hope of interesting some of the students in those professions and also introduces them to the design process as a means of problem solving, teaches them to think how they can affect the built environment and reinforces the importance of teamwork and collaboration by.

Assessment

To evaluate the effectiveness of the program we will conduct both pre- and post- program surveys of teacher candidates and elementary students. The pre-program survey will investigate students' prior knowledge of the distinct work of the professions, their personal interest in pursuing careers in these professions and their perceptions of their math abilities. Teacher candidates will be surveyed to assess their familiarity with the professions, the application of science and math to the professions and their perceptions surrounding their students' abilities and interests. Additionally, we will work with teacher candidates to develop post activity assessment focused on evaluating math concepts that were employed in the Sandcastle Program with the goal of determining if providing a practical application for these concepts enhanced student learning.

Conclusions and Future Steps

This work in progress introduces elementary school students to the design and construction professions through a Sandcastle Project. Its goals are to stimulate creativity, an interest in building design, engineering and construction and to use real world examples of math and science to reinforce standard curricula. Cal Poly College of Architecture & Environmental Design (CAED) and the School of Education are collaborating to bring university student into local elementary school classrooms. Future work includes validation of the program, expanding to more classrooms and improving links with the local design and construction community.

Bibliography

1. Katechi, L., Pearson, G. and Feder, M., Editors, "Engineering in K-12 Education: Understanding the Status and Improving the Prospects," Committee on K-12 Engineering Education, National Academy of Engineering and National Research Council, 2009.

2. President's Council of Advisors on Science and Technology (PCAST), "Prepare and Inspire: K-12 Science, Technology, Engineering and Math - STEM Education for America's Future," Washington, D.C., 2010.
3. Ellis, E.A., Jackson, H. and Wynn, K.K., "Incorporating Engineering in PreK to Grade 12 Curricula through Career Imprinting," Proceedings of the 39th ASEE/IEEE Frontiers in Education Conference, San Antonio, TX, 2009.
4. Brady, P., and Saliklis, E., "The structure of a Story," Proceedings of the 39th ASEE/IEEE Frontiers in Education Conference, San Antonio, TX , 2009.
5. <http://www.leaparts.org>
6. Douglas, J., Iversen, E., and Kalyandurg, C., "Engineering in the K-12 Classroom: An Analysis of Current Practices & Guidelines for the Future," ASEE Washington, D.C., 2004.
7. Duquette, J. and Pederson, J., "How Do Buildings Get Built?" Senior Project, California Polytechnic State University, 2008.
8. Massachusetts Department of Education. "Massachusetts science and technology/engineering curriculum framework." Malden, MA, 2006. www.doe.mass.edu/frameworks/scitech/1006.doc

Creating Accelerated Educational Pathways for Underprepared STEM Students through an Intensive Math Placement Test Review Program

Amelito Enriquez, Denise Hum, Christine Woo, Brandon Price, Danni Redding Lapuz, and Anna Camacho
Cañada College, Redwood City, CA

Abstract

A majority of California community college students enter college with low levels of preparation for college-level work, especially in math. For students interested in pursuing science or engineering degrees, this may mean up to four or five years of coursework before they are eligible to apply for transfer to a four-year institution. As a result, many of them drop out or change majors even before taking transfer-level STEM courses. To facilitate the entry of these underprepared students, Cañada College, a federally designated Hispanic-serving community college in the San Francisco Bay Area, developed the Summer Math Jam, which is a two-week intensive math placement test review program. Implementation of the program over the last four years shows success in improving student performance in the math placement test, in preparing students for success, and in creating a sense of community among program participants. An analysis of student academic performance in subsequent semesters shows significantly higher success and retention rates among Math Jam participants compared to nonparticipants. The success of Math Jam has led to the development of the Mini-Math Jam – a shorter, one-week version of Math Jam that is offered a week prior to the beginning of the fall semester, and during the winter break. Since the initial implementation of Math Jam in summer 2009 the program has served over 1000 students, and enrollments in transfer-level STEM courses have increased significantly, with a higher rate of increase among minority students.

This paper describes the evolution of Cañada College's Math Jam Program, including challenges encountered and the strategies employed to overcome those challenges. The paper will also provide resources that have been developed at Cañada to assist other institutions in developing a similar program to improve the participation and success of underprepared students in STEM.

1. Introduction

A recent report prepared by the President's Council of Advisors on Science and Technology (PCAST) report, "Engage to Excel: Producing One Million Additional College Graduates with Degrees in Science, Technology, Engineering, and Mathematics," indicates that the United States needs to produce one million additional STEM professionals in the next decade in order to retain its historical preeminence in science and technology. The report proposes that addressing the retention problem in the first two years of college is the most promising and cost-effective strategy to address this need.¹ The California Community College System, with its 112 community colleges and 71 off-campus centers enrolling approximately 2.6 million students—representing nearly 25 percent of the nation's community college student population—is in a

prime position to help address the need to strengthen the future STEM workforce.² Community colleges serve as the gateway to higher education for large numbers of students in the U.S., especially minority and low-income students. For instance, almost three-fourths of all Latino and two-thirds of all African-American students who go on to higher education begin their postsecondary education in a community college.³ However, for many of these students the community college gateway does not lead to success. Recent findings on the achievement of California community college students indicate that only one in four students wanting to transfer or earn a degree/certificate did so within six years. African American and Hispanic students have even lower rates of completion; only 14% of African American students and 20% of Latino students completed a degree or certificate within six years, compared to 29% of white students, and 24% of Asian students.⁴

For science and engineering fields, lower success and retention rates for minority students are observed at both community college and university levels resulting in the underrepresentation of minority groups in these fields. For instance, while comprising about 28% of the U.S. population, African Americans and Latinos make up less than 9% of the individuals who are B.S. or higher-degree holders in the science and engineering fields.⁵ Statistics show that these groups of students tend to enroll in STEM majors in small numbers and have higher attrition rates compared to other groups.⁶⁻⁹ Summer programs are among the most commonly employed successful strategies that have been proven effective in increasing the retention and success of minority students in science and engineering, especially those who are educationally disadvantaged.¹⁰⁻¹⁶

In 2008, Cañada College, a Hispanic-Serving community college in Redwood City, CA, was awarded a Minority Science and Engineering Improvement Program (MSEIP) grant by the US Department of Education. The project, entitled Student On-ramp Leading to Engineering and Sciences (SOLES), aims to increase the participation, retention, and success of underrepresented and educationally disadvantaged students interested in pursuing careers in STEM fields. Among the strategies developed for this project is the Summer Math Jam – a two-week intensive mathematics program designed to improve students' preparation for college-level math courses. This paper summarizes the results of the implementation of the Math Jam and its one-week version, the Mini-Math Jam, over the last four years.

2. Incoming Student Interest and Level of Preparation for Engineering

Cañada College is a federally-designated Hispanic Serving community college in the San Francisco Bay Area. The College opened in 1968, and is located in Redwood City, California. During the 2011-2012 academic year, Cañada College enrolled 10,965 students. The student body is multi-cultural with Hispanic students as the largest single group at 35.5%; white students comprise 32.6%, Asians 8.1%, African-Americans 3.9%, Filipinos 3.6%, Pacific Islanders 1.7%, American Indian/Alaska Natives 0.3%, multi-racial 9.5%, unknown 4.9%.¹⁷ Like all of the California Community College System institutions, Cañada is an open-enrollment institution, designed to welcome students of all ages and backgrounds to higher education.

At Cañada College, low degree completion and transfer rates for STEM majors can in part be attributed to inadequate preparation for college-level mathematics courses. Table 1 summarizes the Math Placement test results of Cañada College students from April 2006 to April 2010.

Among all the students who took the placement test, 75.1% placed into either pre-algebra or algebra. For students who declared a STEM major, the results were only slightly better, with 59.6% of students placing into either pre-algebra or algebra. Even among those who declared engineering as their major, over 50% of students placed into one of these two remedial math courses. The results of these math placement tests have serious and adverse consequences for these students' timely completion of lower-division courses, and subsequent transfer to a university.

Table 1. Summary of April 2006 to April 2010 Math Placement Test results for 6300 students of all majors, 697 students who declared STEM majors, and 169 students who declared engineering majors.

Students Who:	Pre-algebra	Algebra	College Algebra	Trigonometry
Took Math placement Test	47.1%	28.0%	17.0%	7.9%
Declared a STEM major	32.9%	26.7%	23.8%	16.6%
Declared Engineering major	20.7%	32.0%	27.2%	20.1%

Table 2 summarizes the ethnic distribution of the math placement test results for students who declared a STEM major. Among the biggest ethnic groups, African American students have the lowest percentages of students placing into trigonometry (6.3%), and the highest percentages of students placing into pre-algebra (71.9%), followed by Mexican Americans with 12.5% placing into trigonometry, and 39.1% placing into pre-algebra.

Table 2. Ethnic distribution of Math Placement test results for students who declared majors in STEM (Data from April 2006-April 2010; 697 students).

Ethnic Group	Pre-algebra	Algebra	College Algebra	Trigonometry	% of Total
African American	71.9%	15.6%	6.3%	6.3%	4.6%
Asian American	20.8%	22.9%	33.3%	22.9%	6.9%
Caucasian	22.9%	31.4%	24.8%	21.0%	30.1%
Mexican American	39.1%	26.2%	22.1%	12.5%	38.9%
Other	30.9%	24.3%	26.5%	18.4%	19.5%
All Ethnicities	32.9%	26.7%	23.8%	16.6%	100.0%

Although nationally, interest in science and engineering is lower for Latino, African American, and Native American students compared to other ethnic groups,⁵ this is not the case at Cañada College. Table 3 summarizes the percentages of students taking the placement test, students declaring STEM majors, students declaring an engineering major, and students who transferred to a four-year school as an engineering major (2006-2010) for the four largest ethnic groups – Mexican Americans, Caucasian, Asian Americans, and African Americans. Although Mexican Americans represent only 37.2% of all the students who took the placement test, they represent

38.9% of students who declared a STEM major, and 46.2% of students who declared engineering as their major. Despite such a high interest in engineering among Mexican Americans, they represented only 19.4% of all students who transferred to a four-year school as engineering majors from 2006-2010. These data clearly indicate a much lower rate of retention and transfer for Mexican Americans compared to Caucasian and Asian Americans.

The first two years of typical engineering curricula require two years of courses that include sequences of courses in calculus and physics. A student who starts at College Algebra has an additional one and a half years of mathematics (College Algebra, Trigonometry and Pre-calculus) on top of the two-year sequence of lower-division transferable courses. A student who starts at Pre-algebra has an additional two and a half years (Pre-algebra, Algebra, College Algebra, Trigonometry and Pre-calculus) of mathematics before they are ready to take Calculus. Hence, 39.1% of Mexican Americans and 71.9% of African American students will need at least four years at Cañada College before transferring. For many of them with family obligations and no family support, this is simply too long of an education path.

Table 3. Summary of the ethnic distribution of Cañada College students who took the placement test (April 2006-April 2010; 6,300 students), who declared STEM majors (697 students), who declared majors in engineering (169 students), and who transferred to a four-year school as engineering majors (2006-2010, 108 students) for the four largest ethnic groups.

Percentage of Students Who:	Mexican American	Caucasian American	Asian American	African American	Other
Took Math placement Test	37.2%	30.2%	5.7%	6.4%	20.5%
Declared a STEM major	38.9%	30.1%	6.9%	4.6%	19.5%
Declared Engineering major	46.2%	27.8%	4.1%	3.6%	18.3%
Transferred as Engr majors	19.4%	21.3%	30.6%	0.9%	27.8%

3. The Summer Math Jam

To address the low levels of preparation of incoming Cañada students, especially those who have expressed interest in pursuing engineering and other STEM majors but placed low in the sequence of math courses, the Summer Math Jam was developed in 2009.

The Summer Math Jam was developed with the following program goals:

1. Help students progress faster through Cañada’s math sequence to enable them to transfer to a 4-year university earlier or to complete an associate’s degree earlier;
2. Increase students’ awareness of the tools, skills, and resources they need to be successful college students; and
3. Develop a community of learners among program participants.

Although originally developed to help students improve the results of their initial math placement tests, Math Jam has evolved a secondary purpose of helping students prepare for a math class that they will be taking. As a result, the program has welcomed repeat participants.

Math Jam participants are grouped into four levels based on students' initial math placement: one group each for Pre-algebra, Algebra and College Algebra, and one group for students in the Trigonometry level or higher. Each group is assigned a Math Jam instructor who is a math instructor, an instructional aide, or an advanced student. Each Math Jam instructor is assisted by a group of student tutors such that four or five students are assigned per tutor for the Pre-algebra group, and up to ten students per tutor for the Trigonometry group. Appendix A shows a summary of the schedule of activities for the 2009 Math Jam, and Appendix B the schedule from 2010 to 2012. All Summer Math Jam sessions were held from 9:00 a.m. to 3:00 p.m., Monday through Thursday during a two-week period that coincided with Cañada College's break between the end of the spring semester and the beginning of the summer term. Morning and afternoon sessions were devoted to studying math either in groups or individually using MyMathTest,¹¹ an online system developed by Pearson Education for developing math placement tests and short math refresher programs. Workshops related to resources and skills needed for college success are offered in the afternoon. As a result of a 2009 mid-program focus group, which indicated that students wanted to devote more time to studying math and less on these workshops, the afternoon college success workshops were made optional for the second week of the 2009 Math Jam and all subsequent Math Jam sessions.

Table 4 summarizes the demographics of Math Jam participants in the last four years. The number of participants more than doubled, from 50 in 2009 to 113 in 2010, and stayed at over 100 for 2011 and 2012. For each year, a majority of participants were female, with Hispanic being the predominant ethnic group. More than half of all Math Jam participants are first in their families to attend college.

Table 4. Demographics of Summer Math Jam participants.

Demographics	2009	2010	2011	2012
Number of Participants	50	113	111	129
Gender				
Female	64.7%	70.2%	63.0%	58.9%
Male	35.3%	25.8%	37.0%	41.1%
Ethnicity				
African American	5.9%	2.1%	5.4%	6.5%
Asian/Pacific Islander	2.9%	10.7%	7.2%	11.3%
Caucasian	20.6%	22.3%	23.4%	23.4%
Hispanic	61.8%	57.4%	55.9%	53.2%
Native American	0.0%	0.0%	0.0%	0.0%
Other	8.8%	7.5%	8.1%	5.7%
First in Family to Attend College?				
Yes	50.0%	54.8%	55.0%	55.7%
No	50.0%	45.2%	45.0%	44.3%

Table 5 is a summary of the results of the four years of implementation of Math Jam. Even though the number of participants more than doubled from 50 in 2009 to 113 in 2010, and remained above 100, the completion rate has remained above 80% for each year – 84% for 2009, 82% for 2010, 91% for 2011, and 82% for 2012. Among students who have pre- and post-program test scores, the percentage of students with higher post-program scores remained above 90% for each year. Among students who retook the placement at the end of the program, the percentage of students who placed into at least the next higher math level was consistently above 50% – 64% in 2009, 56% in 2010, 69% in 2011, and 68% in 2012.

Table 5. Summary of Math Jam results in 2009, 2010, 2011 and 2012.

Summer Math Jam Results	2009	2010	2011	2012
Number of Participants	50	113	111	129
Number Completed	42	93	101	105
Completion Rate	84%	82%	91%	82%
With Pre- and Post-Test Scores	33	71	54	68
Improved Test Scores	94%	91%	96%	97%
% Placed into Higher Level	64%	56%	69%	68%

To evaluate the success of Math Jam in achieving its secondary goals of increasing student awareness of tools, skills and resources needed to succeed in college, pre- and post-program student surveys were administered. Table 6 summarizes student responses to the pre- and post-program surveys for 2011 Math Jam and 2012 Math Jam. Note that the survey questions for 2009 and 2010 were different, and are not included in this summary. For most of the pre- and post-program attitudinal surveys, the survey prompt was: "Tell us how much you agree with the each of the following statements," with a Response Scale of: 5 – Strongly Agree, 4 – Agree, 3 – Neutral, 2 – Disagree, 1 – Strongly Disagree. The average of the student responses for each survey question was computed and is shown in Table 6. For both 2011 and 2012 surveys, the largest increase in the average response (and highest level of statistical significance) is for the prompt "I have effective math study skills." For the 2011 responses, statistically significant improvements from the pre-program responses to the post-program responses are also observed in two additional areas: students' perceived supportive relationships with tutors, and supportive relationships with teachers. For 2012, statistically significant improvements in the pre- and post-program surveys are recorded for four areas in addition to math study skills. These additional areas are: confidence in succeeding in college, students' perceived supportive relationships with other students, supportive relationships with tutors, and supportive relationships with teachers. The recorded decrease in math anxiety and the increases in confidence that Cañada is the right college for them and confidence in selecting an appropriate major are not statistically significant. When asked if participation in Math Jam was helpful, student average responses were very positive (4.63 for 2011, and 4.62 for 2012). When asked if they were more likely to major in STEM as a result of participating in Math Jam, the average responses were 3.23 for 2011, and 3.46 for 2012.

Table 6. Pre- and Post Program Student Survey Results. Prompt: Tell us how much you agree with the following statements. Response Scale: 5 – Strongly Agree, 4 – Agree, 3 – Neutral, 2 – Disagree, 1 – Strongly Disagree.

Attitudes	2011			2012		
	Pre	Post	Δ	Pre	Post	Δ
I feel (was) excited about participating in Math Jam.	3.93	3.99	0.05	4.11	4.16	0.04
I feel anxious about studying math.	3.47	3.41	-0.06	3.43	3.40	-0.04
I have effective math study skills.	3.19	3.69	0.50 ^c	3.09	3.69	0.60 ^c
I am confident that I have the necessary skills and academic preparation to be a successful college student.	4.03	4.20	0.17	3.96	4.20	0.24 ^a
I am confident that Canada College is the right college for me.	4.21	4.32	0.12	4.35	4.39	0.04
I am confident that I have selected an appropriate major.	3.93	4.00	0.07	4.06	4.06	0.00
I have supportive relationships with other students at Cañada.	3.79	4.00	0.21	3.77	4.04	0.26 ^a
I have supportive relationships with tutors at Cañada.	3.67	4.03	0.36 ^a	3.55	3.99	0.44 ^c
I have supportive relationships with teachers at Cañada.	3.68	4.01	0.33 ^a	3.77	4.05	0.28 ^c
It was helpful for me to participate in MJ.	-	4.63	-	-	4.62	-
As a result of participating in MJ, I am now more likely to pursue a STEM major.	-	3.23	-	-	3.46	-

^a The change is statistically significant ($p < 0.050$).

^b The change is statistically significant ($p < 0.010$).

^c The change is statistically significant ($p < 0.001$).

4. Academic Performance of Math Jam Students

To truly evaluate the success of the Math Jam program in helping students achieve their academic goals, the success of the program participants beyond the two-week duration of the program needs to be monitored. To this end, the performance of the 2009 Math Jam participants in the math courses they took in fall 2009 was monitored. Table 7 is a comparison of the performance of three groups of students: 2009 Math Jam students who advanced at least to the next math class during Math Jam, 2009 MJ students who did not advance to the next math class during the program, and all students in fall 2009 math courses. The performance measures compared are the retention rate and success rates in the math courses. The last two columns of Table 7 show that 2009 Math Jam students when taken as a group have higher retention and success rates (75.7% and 62.2%, respectively) compared to all math students in the semester (74.5% and 50.5%, respectively). The third column of Table 7 shows that despite having already

skipped at least one math class, the MJ students who advanced outperformed all the math students in the semester, with higher retention rate (84.2% versus 74.5%), and success rate (68.4% versus 50.5%). These results address some initial concern among math faculty that skipping a math course might result in students being less prepared to be successful in the more advanced math course.

Table 7. Performance of 2009 Math Jam students in fall 2009 math courses.

	MJ Students who Advanced (N=19)	MJ Students who did not Advance (N=18)	All MJ Students (N=37)	All Math Students (N=1515)
Retention Rate	84.2%	66.7%	75.7%	74.5%
Success Rate	68.4%	55.6%	62.2%	50.5%

One of the primary reasons for the low degree-completion and transfer rates among community college students is the low persistence rates, i.e., students not continuing from one term to the next.¹⁹ Table 8 is a comparison of the persistence rates of all first time Cañada students and 2009 Math Jam participants. Over the last several years, a study of first time fall semester Cañada students shows persistence rates of 55% for the following spring semester, 38% for the fall of the following year and 32% for the spring semester of the second year. For the 2009 Math Jam participants, the corresponding persistence rates were 93% for spring 2010, 83% for fall 2010, and 78% for spring 2011. With much higher persistence rates, the degree-completion and transfer rates for these students are expected to be much higher as well.

Table 8. Comparison of persistence rates of all first time Cañada students and 2009 Math Jam participants.

	All First Time Students	2009 Math Jam Attendees
Fall of Yr 1	100%	100%
Spring of Yr 1	55%	93%
Fall of Yr 2	38%	83%
Spring of Yr 2	32%	78%

Two important variables that are commonly believed to strongly influence the retention of students are academic and social integration as articulated by Tinto's model of college student persistence/withdrawal based on these variables.^{20,21} It is often assumed that academic and social integration are more difficult to achieve in the community college setting because of the lack of time to participate in institutional activities that facilitate such integration.²² To enhance opportunities for the creation of academic and social integration, an approach that is of increasing popularity in community colleges is the use of learning communities. Learning communities are small groups of students who take thematically linked classes that are often interdisciplinary in order to enhance academic and social integration of students, and strengthen their cognitive skills.²³ Many studies have concluded that learning communities can significantly increase student retention, especially in developmental courses.²³⁻²⁸

The success of Math Jam in increasing the retention rate among its participants may be analyzed in the framework of Tinto’s academic and social integration model. The intense two-week, 6 hours per day format of Math Jam provides an ideal context for academic and social integration among its participants, and may prove to be as effective as semester- or year-long learning communities programs that are commonly adopted in community colleges to improve student retention. Math Jam’s informal instructional format of individual and group study sessions creates a relaxed and supportive learning environment. Additional opportunities for social/non-academic interactions arise during snack and lunch breaks, and during optional afternoon workshops that explore students’ strengths and weaknesses, as well as skills, resources and attributes important for college success. This creates a sense of integration and connectedness that is evident in the results of participant responses to the pre- and post-program surveys – statistically significant increases to student perceived supportive relationships with Math Jam tutors and with other participants.

5. Mini-Math Jam

Because of the success of the summer Math Jam, and student demand for it, Cañada College decided to offer Mini-Math Jam sessions. Mini-Math Jam is a one-week version of Math Jam offered a week before the beginning of the semester, and is designed to help students prepare for taking a math class during the semester. Since 2010, two Mini-Math Jam sessions per year have been offered, one in January and one in August, and the results are summarized in Table 9.

As with the two week Math Jam, the one week Mini-Math Jam completion rate has remained above 80% for each cohort. Among students who retook the placement at the end of the program, the percentage of students who placed into at least the next higher math level was above 50% for four of the six Mini-Math Jam cohorts.

Table 9. Summary of the results for the 2010 winter and 2010 summer mini-Math Jam.

Mini-Math Jam Results	2010		2011		2012	
	Jan	Aug	Jan	Aug	Jan	Aug
Number of Participants	87	74	107	113	168	130
Number Completed	76	67	87	93	142	106
Completion Rate	87%	91%	81%	82%	84%	82%
% Placed into Higher Level	36%	61%	69%	56%	61%	38%

6. Effect on STEM Enrollment

The success of the Math Jam and Mini-Math Jam programs has contributed to significant enrollment increases in transfer-level courses in math, sciences and engineering. Table 10 shows the percentage increases in enrollment in STEM courses among minority and non-minority students from fall 2008 to fall 2012. Since fall 2008, the base year of the Math Jam program, enrollments in transfer-level courses in math, engineering, biological and physical sciences have increased significantly. The percentage increase in the number of minority students enrolled in these courses is significantly higher than the percentage increase for the non-minority groups for

both engineering (233.3% for minority students vs. 87.8% for non-minority students) and mathematics (224.4% for minority students vs. 173.3% for non-minority students). It should be noted that among the STEM areas, engineering, math and physics courses have higher prerequisite math courses beyond College Algebra. Enrollment in transfer-level courses in these subject areas is highly dependent on timely completion of the required sequence of math courses, a direct effect of successful participation in Math Jam. Over the same period, overall college enrollment increased by 5.0%, significantly lower than the increase for transfer-level STEM courses.

Table 10. Comparison of percentage increase in enrollment in selected STEM areas for minority and non-minority students for fall 2012. All percentage changes are with respect to the program base year of fall 2008.

	Minority	Non-minority	All Students
Engineering	233.3%	87.8%	126.8%
Mathematics	224.4%	173.3%	189.8%
Chemistry	96.9%	174.6%	148.4%
Physics	55.6%	75.0%	69.3%
Biological Sciences	19.31%	27.1%	24.5%

7. Conclusion

Through four years of implementation, Math Jam has been successful in achieving the program’s primary goal of helping students progress faster through Cañada’s math sequence. A majority of students who have pre- and post-program math placement test scores placed into at least the next higher math course. This results in a reduction of the cost and time for these students to complete their degrees and/or the lower-division courses they need to transfer to a four-year institution.

Math Jam has also been successful in increasing students’ awareness of college success tools and skills, and in creating a community of learners that felt comfortable at Cañada. Academic performance of Math Jam participants in semesters following their participation in the program was significantly better both in the areas of retention and success rates, indicating the effectiveness of the program. Even more remarkable is the significantly higher persistence rate of Math Jam participants, with a one-year persistence rate that is double that of the College’s rate among first-time students based on historical data. The improved persistence may be attributed to the enhanced academic and social integration experienced by Math Jam participants brought about by an intense and focused yet informal instructional atmosphere that fosters a sense of community among program participants, and a feeling of connectedness to the program staff and the College as a whole. These results indicate that shorter programs may be as effective as, or even more effective than traditional semester-long or year-long learning communities in creating opportunities for student engagement and immersion into the college experience in order to increase student persistence.

Math Jam was designed primarily to help students who have expressed interest in a STEM field but have low levels of preparation for taking college-level math courses as indicated by their math placement test results. Due to high interests in STEM and low placement test scores, participation in the program was higher among minority students compared to non-minority students. This higher rate of participation among minority students and the success of Math Jam in enhancing their academic performance are reflected in the increase in enrollment in transfer-level courses since the program was initiated. Although enrollments in STEM transfer-level courses have increased for all student groups and for all STEM areas, the rates of increase are significantly higher among minority students, especially for engineering, mathematics, and physics where minority student enrollment has traditionally been lower due to inadequate high school preparation in math.

The success of Math Jam has prompted Cañada College to institutionalize the program. Beyond the duration of the three-year Minority Science and Engineering Improvement Program grant that funds the Math Jam, the College will continue to implement and improve the program and contribute to the strengthening of the STEM educational pipeline for students from underrepresented groups. Additionally, through funding from the US Department of Education Hispanic Serving Institution Science, Technology, Engineering, and Mathematics (HSI STEM) program, an Evening Math Jam has also been developed for evening students who are unable to attend the day-time Math Jam. It was successfully implemented for the first time in summer 2012, with results similar to the day-time program. Other similar intensive programs have also been piloted at Cañada including Word Jam for students preparing to take an English or English-as-a-Second-Language (ESL) course, and Physics Jam for students preparing to take the first semester of college physics.

As more students choose the community college pathway towards careers in science, technology, engineering, and mathematics, more programs like Math Jam need to be developed in order to produce the well-educated work force that is needed to ensure that the United States remains the premier place in the world for innovation.

Acknowledgements

This project was supported by two grants from the US Department of Education: Minority Science and Engineering Improvement Program (MSEIP, Award No. P120A080080), and Hispanic-Serving Institution Science, Technology, Engineering, and Mathematics (HSI STEM, Award No. P031C110159).

Bibliography

1. President's Council of Advisors on Science and Technology (PCAST). (2012). Engage to excel: Producing one million additional college graduates with degrees in science, technology, engineering, and mathematics. Retrieved December 2012 from: http://www.whitehouse.gov/sites/default/files/microsites/ostp/pcast-engage-to-excel-final_2-25-12.pdf

2. California Community Colleges Student Success Task Force (CCCSSTF). (2012). *Advancing student success in California community colleges*. Retrieved December 2012 from http://www.californiacommunitycolleges.cccco.edu/Portals/0/StudentSuccessTaskForce/SSTF_FinalReport_Web_010312.pdf
3. The Civil Rights Project. (February 14, 2012). *Civil Rights Project reports call for fundamental changes to California's community colleges*. (Press release). Retrieved December 2012 from <http://civilrightsproject.ucla.edu/news/press-releases/crp-press-releases-2012/crp-calls-for-fundamental-changes-in-californias-community-colleges>
4. Shulock, Nancy & Moore, Colleen (2010). *Divided We Fail: Improving Completion and Closing Racial Gaps in California's Community Colleges*. Retrieved on March 2012 from http://www.csus.edu/ihelp/PDFs/P_DWF_11_10.pdf
5. National Science Foundation, Division of Science Resource Statistics (2011). *Women, Minorities, and Persons with Disabilities in Science and Engineering*, Arlington, VA, Retrieved March 2012 from <http://www.nsf.gov/statistics/wmpd/pdf/nsf11309.pdf>
6. Urban, J., Reyes, M., and Anderson-Rowland, M. (2001). Minority engineering program computer basics with a vision, *32nd ASEE/IEEE Frontiers in Education Conference* pp. S3C1-5 Retrieved December 2012 from <http://fie2012.org/sites/fie2012.org/history/fie2002/papers/1060.pdf>
7. Hobson, R, and Alkasawneh, R. (2009). Summer Transition Program: A Model for Impacting First-Year Retention Rates for Underrepresented Groups, , in *ASEE Conference & Exposition*, Austin, TX, 2009.
8. Besterfield-Sacre, M., Atman, C., and Shuman, L. (1997). Characteristics of Freshman Engineering Students: Models for Determining Student Attrition in Engineering, " *Journal of Engineering* , vol. 86, pp. 139-150.
9. Fleming, L., Ldebetter, S., and Williams D. (2008). Engineering Students Define Diversity: An Uncommon Thread, *2008 ASEE Conference & Exposition*. Retrieved December 2012 from http://es21c.okstate.edu/resources/Publications/1039_ENGINEERING_STUDENTS_DEFINE_DIVERSITY_A.pdf
10. Goldberg, J. & Sedlacek, W. (1996), *Summer Study in Engineering for High School Women*, Maryland University, College Park, Maryland. Retrieved December 2012 from http://www.eric.ed.gov/ERICDocs/data/ericdocs2sql/content_storage_01/0000019b/80/14/b7/70.pdf.
11. Pantano, J. (1994), *Comprehensive Minority SEM Programs at Santa Fe Community College*, Paper presented at the Annual International Conference of the National Institute fo Staff and Organizational Development on Teaching Excellence and Conference of Administrators, Austin, TX, May 22-25, 1994.
12. Murphy, T. E., Gaughan, M., Hume, R., & Moore, S. G. (2010). College graduation rates for minority students in a selective technical university: Will participation in a summer bridge program contribute to success? *Educational Evaluation and Policy Analysis*, 32(1), 70-83.
13. Raines, J. (2012). A Preliminary Review of the Effects of a Summer Bridge Program on Pre-College STEM Majors, *Journal of STEM Education*, 13(1), 22-29.
14. Allen, D., & Bir, B. (2012). Academic Confidence and Summer Bridge Learning Communities: Path Analytic Linkages to Student Persistence, *Journal of College Student Retention*, 13(4), 519-548.
15. Stolle-McAllister, K. (2011). The Case for Summer Bridge: Building Social and Cultural Capital for Talented Black STEM Students, *Science Educator*, 20(2) 12-22.
16. Lenaburg, L., Aguirre, O., Goodchild, F., & Kuhn, J. (2012). A Summer Bridge Program for Community College STEM Students. *Community College Journal of Research and Practice*, 36(3), 153-168.

17. Cañada College (2012). *Program Review Data Packets College Totals*, Retrieved December 2012 from http://www.canadacollege.edu/inside/research/programreview/info_packet/academic_year/Canada.pdf
18. Pearson Education (2010). *MyMathTest*. Pearson Education. Retrieved December 2012 from http://mymathtest.com/login_mmt.htm.
19. O'Banion, T. (2010). The Completion Agenda: To What End? Emerging Philosophy Shifts Focus from Student Access to Success, *Community College Journal*, 81(2), 44-47.
20. Tinto, V. (1993). *Leaving College: Rethinking the causes and cures of student attrition* (2nd ed.). Chicago: University of Chicago Press.
21. Tinto, V. (1975). Dropout from Higher Education: A Theoretical Synthesis of Recent Research, *Review of Education Research*, v45, 89-185.
22. Karp, M., Hughes, K., & O'Gara, L. (2010). An Exploration of Tinto's Integration Framework for Community College Students, *Journal of College Student Retention: Research, Theory & Practice*, v12 n1 p69-86.
23. Visher, M., Schneider, E., Wathington, H., & Collado, H. (2010). Scaling up Learning Communities: The Experience of Six Community Colleges, National Center for Postsecondary Research. Teachers College, Columbia, Retrieved December 2012 from <http://www.eric.ed.gov/PDFS/ED509307.pdf>
24. Tinto, V., Goodsell-Love, A., & Russo, P. (1994). *Building Learning Communities for New College Students: A Summary of Research Findings of the Collaborative Learning Project*. University Park, PA: Pennsylvania State University, National Center on Postsecondary Teaching, Learning, and Assessment.
25. Smith, B., & MacGregor, J. (2009). Learning Communities and the Quest for Quality, *Quality Assurance in Education: An International Perspective*, 17(2), 118-139.
26. Barnes, R., & Piland, W. (2010). Impact of Learning Communities in Developmental English on Community College Student Retention and Persistence, *Journal of College Student Retention: Research, Theory & Practice*, 12(1), 7-24.
27. Weiss, M., Visher, M., & Wathington, H. (2010). *Learning Communities for Students in Developmental Reading: An Impact Study at Hillsborough Community College*, National Center for Postsecondary Research. Teachers College, Columbia University. Retrieved March 2012 from <http://www.eric.ed.gov/PDFS/ED510961.pdf>
28. Arnett, A., & Van Horn, D. (2009). Connecting Mathematics and Science: A Learning Community that Helps Math-Phobic Students, *Journal of College Science Teaching*, 38(6), 30-34.

Appendix A
2009 Math Jam Schedule

Week 1

	June 8	June 9	June 10	June 11	June 12
Time	Monday	Tuesday	Wednesday	Thursday	Friday
9-10 am	Welcome & Ice Breaker	Math Study Skills	Math!	Math!	
10 -12 pm	Placement Test / Review Results	Math!			
12-12:30 pm	Lunch	Lunch	Lunch	Lunch & Mesa Panel	Lunch
12:30-1 pm	Meet the staff & Overview of Math Jam	Math Anxiety Assessment	Financial Aid		Field Trip
1-1:30 pm	Time Management	Ed Plan Counseling OR Math Anxiety Workshop	Ed Plan Counseling OR Time Management		
1:30-2 pm	Why an Education Plan?				
2-2:20 pm	Signups for Work Sessions				
2:20-2:30 pm		Individual Ed Plan Counseling Skills Counseling	Individual Ed Plan Counseling Skills Counseling	Individual Ed Plan Counseling Skills Counseling	
2:30-3:00 pm [Optional]					

Week 2

	June 15	June 16	June 17	June 18	June 19
Time	Monday	Tuesday	Wednesday	Thursday	Friday
9-10 am	Math!	Math!	Math!	Post-Program Survey	
10 -12 pm				Placement Test	
12-12:30 pm	Lunch	Lunch	Lunch	Lunch & Guest Speaker	Barbecue and Closing Ceremony
12:30-1 pm	LEAP Strengths Quest	Math!	Math!		
1-1:30 pm					
1:30-2 pm	Math Jam and You	Transfer OR Graphing Calc Workshop			
2-2:30 pm		Individual Ed Plan Counseling / Skills Counseling	Individual Ed Plan Counseling / Skills Counseling	Individual Ed Plan Counseling / Skills Counseling	
2:30-3:00 pm [Optional]					

Appendix B
2010-2012 Math Jam Schedule

Week 1

Time	Monday	Tuesday	Wednesday	Thursday
9-10 am	Welcome & Pre-Program Survey	Math!	Math!	Math!
10 -12 pm	Placement Test / Review Results			
12-12:30 pm	Lunch	Lunch	Lunch	Lunch
12:30-2:30 pm	Math!	Math!	Math!	Math!
2:30-3:00 pm	Math!	Time Management or Math!	Math!	Math Anxiety or Math!

Week 2

Time	Monday	Tuesday	Wednesday	Thursday
9-12 pm	Math!	Math!	Math!	Math Placement Test Post-Program Survey
12-12:30 pm	Lunch	Lunch	Lunch	Lunch
12:30-2:30 pm	Math!	Math!	Math!	Group Photo
2:30-3:00 pm	Math!	Math!	Test Taking Strategy or Math!	Math!

Ethics in Engineering: Preparing Our Students to Meet Societal Obligations

**Jim Helbling, Angela Beck
Embry-Riddle Aeronautical University, Prescott**

Abstract

This paper discusses a work in progress, reporting on how societal ethics are incorporated into a senior-level capstone course, AE 421: Aircraft Detail Design, taught at Embry-Riddle Aeronautical University (ERAU), Prescott campus. Specifically, this paper focuses on how the course instructors prepare these aerospace engineering students to perform as professional engineers as per ABET criteria 3f and 3h. By helping these students to become increasingly aware of their impact on society and by allowing them to practice ethical decision-making while in college, the instructors prepare students to engage in ethical behavior on the job.

Ethics are embedded in this detail design course in several ways, each of which is explained and exemplified in this paper. As an example of the ethical topics and practices embedded in this course, students are required to design and fabricate wind tunnel models and structural test articles to strict material budgets. This effort requires the student design teams to understand the need to make economic decisions and balance design requirements relative to cost. The material selection process also requires an understanding of environmental concerns, the potential for recycling excess material, the proper disposal of waste products, and safe machine shop practices (i.e., the practice of social responsibility)

While there are a variety of ethical practices incorporated into this senior design course (e.g., fair distribution of engineering tasks, accurate reporting of work hours, professional negotiation of interpersonal conflicts), the most overt example involves an invitation to all graduating seniors to join the Order of the Engineer organization. This society requires all inductees to recite an oath promising to always perform their jobs with integrity and with an understanding of the impact that they have on society if they fail to do so. The invitation is directly applicable to the pressures the students feel as a part of the class, where they are required to perform testing to evaluate analytical predictions under tight schedules, thus learning to ethically report test results. The goal is for students to assimilate these lessons regarding their professional responsibilities as they transition from student to practicing engineer.**Ethics and ABET Criteria**

ABET criterion 3f and 3h state that students must have “an understanding of professional and ethical responsibility” and “the broad education necessary to understand the impact of engineering solutions in a global, economic, environmental, and societal context”, respectively¹. In order to assist students in achieving these outcomes, the faculty teaching Aircraft Detail Design at ERAU, Prescott campus, have adopted educational practices designed to emphasize ethics in the engineering workplace. This paper will provide a brief description of Aircraft Detail Design, highlight specific ethical practices, explain the iterative teaching method used to help students assimilate these practices, and suggest ways for engineering instructors to incorporate similar practices in their own engineering courses. These practices include social responsibility

as demonstrated through budgetary and environmental responsibility professional ethics as demonstrated through the ethical reporting of results obtained through physical testing of student designs, and the maintenance of these ethical standards as our students transition from academic to professional life.

Ethics in Aircraft Detail Design

Aircraft Detail Design is one of the senior capstone design courses offered at ERAU, Prescott campus. Aircraft Detail Design student design teams are formed in a previous semester and each is led by a design team lead. This capstone class requires students to verify aerodynamic and stability predictions through wind tunnel testing, to predict the structural response to load of an aircraft component (e.g., a wing section) through analysis and simulation, and to attempt to verify these structural response predictions through the manufacture and test of a test article representative of the component. A design-build-fly option is also available for some teams who choose to further evaluate their designs through flight test. There are numerous objectives and a tight schedule, and all teams must document their work, both in writing and in a series of formal presentations.

In order to better prepare these engineering students for their professional lives, the faculty teaching Aircraft Detail Design have incorporated social responsibility and professional ethics into the course content. The course content will be described, and then the iterative method used for teaching this content will be explained.

A primary example of this type of ethical course content is the requirement for students to understand economic contexts by maintaining budgets. First, students are given budgetary restrictions to which they must adhere in terms of wind tunnel model fabrication. Wind tunnel models are primarily fabricated from rapid prototyped materials with an estimated cost of \$5.00 per cubic inch. The budget allocated for each team is \$550.00 based on previous wind tunnel model fabrication experience. Students must design their models to be structurally sound while maintaining this budget. This design task is challenging due to the strength limitations of the rapid prototype material. Steel substructure is included in the models to provide strength and to allow the models to mount to the wind tunnel balances. This steel substructure is obtained from existing stock in the ERAU Machine Shop, and students are required to investigate this existing stock in order to minimize costs to the university. By designing their models to meet the \$550.00 budgetary restriction, documenting their expenditures, and investigating the most cost-effective means of fabrication, students engage in more socially responsible engineering. An image showing an example of a completed wind tunnel model is provided in [Figure 1](#) below:



Figure 1- Wind Tunnel Model

This figure shows the external profile of the model comprised of the rapid prototyped material, with the internal steel substructure not visible.

Second, students are provided a \$500.00 budget for the manufacture of the structural test articles. Each design team performs a material trade study considering both composite material and aluminum alloys in which they evaluate strength-to-cost efficiency as one of the primary criteria. Once the material is selected, the design teams are given full responsibility for ordering material in the various product forms required, accounting not only for the cost of the material itself but also for shipping and handling. Students must also account for any additional expenses required for test article assembly, e.g., fasteners or epoxy. In so doing, students learn the relationship between material cost and design requirements and how to achieve design goals in the most cost-efficient manner possible. They also engage in socially responsible budgetary practices, e.g., bundling multiple orders to minimize shipping costs. An image showing an example of a structural test article model during fabrication is provided in [Figure 2](#) below:



Figure 2 – Structural Test Article

Figure 2 shows the aluminum skin of a test article being riveted to sub-structural components (which are not visible in this image).

A further example of ethical course content in Aircraft Detail Design is the requirement for students to formally document the impact that their material selections have on the environment and personal safety. Students are required to research and abide by Material Safety Data Sheets that identify potential environmental concerns and safety hazards for their chosen materials. For example, students must evaluate whether their selected material is recyclable and must identify any special procedures needed to safely dispose of the material so as to cause minimal impact to the environment. This evaluation is included in the material trade study previously discussed and lends itself to the choice of material. Moreover, students must consider their personal safety as a part of the environment. For example, they must wear dust masks and gloves when working with composite materials and must only work in well ventilated areas to avoid inhalation of dust and epoxy fumes². An image showing the process of manufacturing a composite structural test article is provided in Figure 3, below:



Figure 3 – Composite Material Manufacturing Process

The gloves worn by students as a precaution during the application of epoxy to the structural test article are shown in [Figure 3](#).

The ethical content exemplified above is incorporated into the course using an iterative pedagogical process involving lecture and discussion, guided practice, independent practice, and assessment:

Lecture and Discussion: Topics specific to the current phase of analysis, manufacturing, or testing are incorporated into the lecture followed by class discussion. Students are encouraged to share their expectations as to how these ethical concepts are enacted in industry and, if they have had internships, to share ethical problems they may have encountered in industry. Faculty (who have 20+ years experience in aerospace engineering) share their own experiences with ethical dilemmas, focusing on the consequences of unethical behavior to the individual, the company, and society. For example, a lecture early in the semester provides guidelines for making engineering decisions that allow the teams to remain within their allotted budgets, and faculty may discuss the ramifications of companies failing to remain within budget.

Guided Practice: Under the supervision of the course instructors, students are guided through some of the engineering or business practices that incorporate these ethical topics. As is typical of the mentoring strategy used in this class, faculty model proper behavior or practices, students attempt the same practices, and faculty provide feedback and correction as needed. For example, faculty would guide students in meeting the budget for the fabrication of the wind tunnel model.

Independent Practice: Over time faculty remove the “scaffolding” and allow students to engage in these behaviors and practices on their own, integrating them into their professional behavior. For example, once students were able to responsibly create a budget for the fabrication of their wind tunnel model, they would be required to independently create a budget for the fabrication of the structural test article.

Assessment: Ethical behavior is notoriously hard to assess; nonetheless, the faculty use several methods to triangulate behavior and to assess whether students have adopted the desired behaviors as regards social responsibility and professional ethics; these methods include peer evaluations, written documentation, and verbal defenses. Peer evaluations are used at midsemester and end of semester so that students may evaluate their teammates’ responses to ethical dilemmas. These evaluations include written comments which are read verbatim to each teammate; the faculty discuss these comments with the students, explore why they responded to the dilemmas as they did, and if necessary, help students develop strategies for improving their responses. In addition to peer evaluations, the results of our students’ ethical decisions are assessed through documentation of test results and verbal defense of these results at midterm and end of semester. The verbal defense is given to a panel of industry experts who often question why and how students made certain decisions, especially if those decisions demonstrate lack of social or professional responsibility. The goal is to help students understand that they are not acting in a social vacuum and that there are personal and social consequences for acting with or without integrity.

Using these iterative teaching practices, students are provided opportunities to not only talk about but incorporate certain ethical practices into their professional behavior.

It is one thing for students to demonstrate ethical behavior in the classroom; it is another for them to pledge to act ethically throughout their careers. The most overt ethical practice is the invitation to all students enrolled in Aircraft Detail Design to join the Order of the Engineer. The Order is an organization comprised of engineers who have taken an oath, called the Obligation of the Engineer, to always perform their jobs ethically and with an understanding of the impact on society if they fail to do so. The Obligation states:

“I am an Engineer. In my profession I take deep pride. To it, I owe solemn obligations. Since the Stone Age, human progress has been spurred by the engineering genius. Engineers have made usable nature’s vast resources of material and energy for Mankind’s

benefit. Engineers have vitalized and turned to practical use the principles of science and the means of technology. Were it not for this heritage of accumulated experience, my efforts would be feeble.

As an Engineer, I pledge to practice integrity and fair dealing, tolerance and respect, and to uphold devotion to the standards and the dignity of my profession, conscious always that my skill carries with it the obligation to serve humanity by making the best use of Earth's precious wealth.

As an Engineer, I shall participate in none but honest enterprises. When needed, my skill and knowledge shall be given without reservation for the public good. In the performance of duty and in fidelity to my profession, I shall give the utmost."³

This oath overtly addresses the engineer's responsibility to society in terms of the environment and safety. As a part of the discussion of ethics in Aircraft Detail Design, the engineering instructor informs the students that he is the campus coordinator for the Order of the Engineer and that because they are seniors within one semester of graduation, these students will be invited to join the Order at the end of the semester. Introducing the Order of the Engineer early on in the semester allows ethics to be introduced as critical course content.

This emphasis on ethical behavior becomes more critical as the semester progresses. As noted earlier, one of the primary outcomes of this course is to allow students to evaluate simulation through collection of measured test data; students must perform this evaluation under a tight schedule and so the class is oftentimes a high stress work environment. Moreover, because design teams may acquire test data that do not match their simulated predictions and have no time to re-assess their predictions or to re-test, students must decide how to justify their findings while remaining accurate, objective, and truthful.

At the end of the semester, students are invited to participate in a ceremony during which they recite the Obligation of the Engineer and in response receive a certificate bearing the Obligation and a stainless steel ring. This ring is worn on the little finger of the dominant hand so that when the engineer signs a document they hear a click from the ring; this audible click is meant to remind them of the oath. This reminder is meant to preclude the engineer from signing a document that contains false information. The ring also acts as a symbol of the engineering profession and is recognizable as such. The majority of students passing Aircraft Detail Design decide to accept this invitation, pledging to act with integrity in their professional lives.

Recommendations

The incorporation of ethics in Aircraft Detail Design has successfully allowed the students enrolled in this course at the ERAU, Prescott campus to meet ABET criteria 3f and 3h. For engineering faculty who wish to incorporate ethics into their own courses, we have the following recommendations:

1. For laboratory or design courses where the experimental object or test article is fabricated by the students, we suggest that the students be allowed to manage their own budgets and thus practice social responsibility.
2. For these same courses, we suggest that students be required to evaluate the materials used in fabrication in terms of both environmental impact and personal safety during the manufacturing process.
3. For courses offered to seniors, we suggest that the faculty contact their campus coordinator for the Order of the Engineer or, if one does not exist, to contact the Order directly. We further suggest that faculty introduce the Obligation of the Engineer as course content and use it as a framework throughout the semester for the discussion of ethics. Faculty may join the Order and may in turn induct their students into the Order.

By incorporating these practices into engineering courses, faculty will prepare students for ethical behavior in professional life.

Bibliography

1. ABET. (2011). 2012-2013 Criteria for Accrediting Engineering Programs. Baltimore, MD: ABET Engineering Accreditation Commission.
2. Carbon Composites, Inc. (2009). Material Data Safety Sheet: Carbon Composites. Retrieved from <http://www.carboncompositesinc.com/>
3. Order of Engineer. (2013). Obligation of the Engineer. Retrieved from <http://www.order-of-the-engineer.org/>

Enhancing Learning Techniques in Undergraduate Mechanical Design Classes

Nina Robson
Assistant Professor
Mechanical Engineering
California State University Fullerton, CA

Abstract

The paper discusses two different challenges, presented in the form of two projects, as a part of the Introduction to Mechanical Design class at California State University, Fullerton, using inquiry and project based learning approaches, respectively. The students take the theoretical ideas of mechanical design and implement them with moderate guidance for the first project and limited faculty involvement in the second project. In order to assess the approach, we use techniques to uncover what the students are asking themselves as they try to solve each challenge. Based on these questions, the main project objectives such as critical thinking, responsibility for students' own learning and intellectual growth, are discussed.

Introduction

An instructional strategy that comes close to emulating the constantly changing demands of our society is inductive teaching ^[1]. In this approach, the students are first presented with a challenge and they attempt to solve it. Learning takes place while students are trying to understand what they need to know to address that challenge. Students tackling these challenges quickly recognize the need for facts, skills, and a conceptual understanding of the task at hand. At that point, the faculty provides minimal instruction to help students learn on their own. Bransford, Brown, and Cocking ^[2] survey extensive neurological and psychological research that provides strong support for inductive teaching methods. Ramsden ^[3], Norman and Schmidt ^[4] and Coles ^[5] also demonstrate that inductive methods encourage students to adopt a deep approach to learning. Felder and Brent ^[6] show that the challenges provided by inductive methods serve as precursors to intellectual development. Prince and Felder ^[7] review applications of inductive methods in engineering education, and state the roles of other student-centered approaches, such as active and cooperative learning, in inductive teaching. Inquiry learning is one form of inductive methods and begins when students are presented with questions to be answered, problems to be solved, or a set of observations to be explained ^[8]. The same statements could also be made about problem-based learning, project-based learning, discovery learning, certain forms of case based instruction, and student research, so that inquiry learning may be considered an umbrella category that encompasses several other inductive teaching methods. Lee makes this point, observing that inquiry is also consistent with interactive lecture, discussion, simulation, service learning, and independent study, and in fact “probably the only strategy that is not consistent with inquiry-guided learning is the exclusive use of traditional lecturing ^[9].”

The sections that follow provide an overview of our efforts to improve the learning environment

Proceedings of the 2013 American Society for Engineering Education Pacific Southwest Conference
Copyright © 2013, American Society for Engineering Education

for undergraduate engineering students by presenting two activities in the form of challenges, which incorporate inductive teaching methods in small team environment.

Course Objectives

Education must prepare learners to cope with changes that will increase in complexity throughout their lives. Education cannot give learners all the information that they need to know, but rather it must provide the tools for continuing to learn. Keeping that in mind, the main objectives of the Introduction to Mechanical Design course were the following:

1. Ability to apply knowledge of mathematics, statistics, science and engineering
2. Ability to design a system, component or process to meet desired needs within realistic constraints
3. Ability to identify, formulate and solve engineering problems
4. Ability to use the techniques, skills and modern engineering tools necessary to engineering practice.

The process for integrating inquiry techniques into the course, contained designing activities, assignments, and assessments that are congruent with the four desired student outcomes: (a) improved critical thinking skills, (b) greater capacity for independent work, (c) taking more responsibility for one's own learning, (d) intellectual growth, congruent with the above mentioned goals and objectives.

In what follows, we discuss the two projects, Device Analysis and Design Challenge, both presented in the 'Fall 2012 as a part of the Introduction to Mechanical Design class at California State University.

Device Analysis: Project Scope

In the 'Fall 2012 a project activity was presented to the students, *using guided inquiry learning architecture*.

Students were given a hands-on problem to find a real-world mechanical device, disassemble it and analyze a mechanism of their choice, as a part of the device. The activity was designed such that students work either individually or in a group of two for two weeks in order to solve the problem.

In the end of the two-week period, the students were asked to presented their device analysis projects in front of the class, following seven main topics:

1. Description of the device and its operation.
2. Description of the science and engineering fundamentals.
3. Photographs of the device assembled and disassembled.
4. Photographs of the mechanism and its components.
5. Calculations and summary of the analysis.
6. Conclusions.
7. Possible ideas for improvements.

While the strategy was meant to be highly student-focused, the extent of teacher-directed vs. student-directed learning was varying depending on the level of the different students and their understanding of the inquiry process. On average, the amount of faculty involvement in the project was moderate. For this project the students mainly had to use the theoretical knowledge they had gained from the first part of the class.

Design Challenge: Project Scope

About a month later, after the completion of the first project, the students were presented with a second challenge, using *project based learning approach*. The overall goal of the open-ended challenge was to propose a design for a passive suspension for wheeled robotic platform suited for operation on rough terrain. The beauty of the open-ended problem was that the students become emotionally involved, as the available information is insufficient to solve the problem and the students must generate the missing information, which makes the answer unique to the student. The answer that the student gets to the open-ended problem is not as important as the student's logic and rationale for his/her design.

The students had to be able to develop selection criteria considering all relevant issues, develop and evaluate alternative solutions and chose a solution. The goal of the project was to give the engineering undergraduates understand and apply design tools and skills such as:

- sketching and drawing, in order to communicate design ideas in the team environment;
- kinematics, in order to understand what will work and what not and evaluate alternative solutions;
- statistics, to be able to analyze data;
- communication skills to learn how to work in an engineering environment and understand relationships between different concepts;
- ability to take decisions and defend them.

As a part of the learning process, the students had to work in teams of two and were notified that the faculty involvement in the project will be minimal.

Effectiveness of the Two Learning Environments

Anonymous survey questions (see Appendix A and Appendix B) were performed, based on the main course objectives, regarding the effectiveness of the two approaches based on students' perspective. Forty-eight students completed the survey. Table 1 shows the average learning outcomes from the two projects, based on student perception on a scale from 1 (poor) to 5 (excellent). Despite the fact that the Design Challenge was more complicated and the students worked without direct faculty assistance, the student learning outcomes were higher at 4.38 out of 5 versus 4.1 out of five.

Table 1 also shows the top and bottom three scored questions, based on student perception. The first project revealed areas that the students did not feel comfortable with, such as ability to take decisions and defend them, as well as ability to analyze a real-world mechanism. These issues were taken into account by the faculty and were substantially improved in the second project. This implies the faculty's efforts in emphasizing critical thinking and intellectual growth throughout the semester.

*Proceedings of the 2013 American Society for Engineering Education Pacific Southwest Conference
Copyright © 2013, American Society for Engineering Education*

Table 1. Learning Outcomes, Based on Students' Perception.

Project	Top Two Scored Questions (see Appendix)	Lowest Two Scored Questions (see Appendix)	Average Learning Outcomes (from 1 to 5)
Device Analysis	1, 2	7, 8	4.1
Design Challenge	7, 8	1, 6	4.38

In an effort to get some ideas on enhancing the inductive teaching methods used, as a part of each survey, the students were asked to identify three questions that they were asking themselves, while solving each project. Later, the students' questions were classified into three major groups, according to the desired outcome goals: critical thinking, responsibility for one's own learning and intellectual growth. The results from the two projects are shown in Table 2.

The critical thinking, was assessed by the number of students' questions with regard to their interest in analyzing data, evaluating alternative solutions, taking critical decisions, and communicating design ideas.

The comparison in students' responsibility of their own learning was assessed by the number of student's questions regarding their desire to learn more, be successful and look for additional sources, out of the class.

The comparison in intellectual growth, between the two projects, was assessed by the number of student's questions regarding their ability/desire to propose improvements to a design, to find out the relationships between different concepts and to defend their design decisions.

Table 2. Comparison in Critical Thinking, Responsibility for One's Own Learning and Intellectual Growth between the two Challenges, Based on Student's Questions.

	Number of Questions, related to Critical thinking	Number of Questions, related to Responsibility to one's own learning	Number of Questions related to Intellectual growth
Inquiry/Discovery Learning (Device Analysis)	29	7	21
Project-Based Learning (Design Challenge)	41	26	35

Given the difficulty (if not impossibility) of carrying out a clean and conclusive comparative study, the best we could do is to look at the results to see if any robust generalizations can be inferred.

Forty-eight students participated in the Survey. From the 144 students' questions, 57 questions from the Device Analysis and 102 questions from the Design Challenge projects seemed to

comply with the three desired outcomes. Most of the students' questions (70) were related to critical thinking, fifty-six to intellectual growth and only thirty to responsibility to one's own learning. However, a simple comparison between the two projects shows that responsibility to one's own learning was the category that improved the most.

Lessons Learned

It is not quite easy to make a comparison in order to get any conclusion as to which of the two methods revealed more positive qualities from students', as well as from faculty perspective. However it can be seen that presenting two different projects using two different inductive approaches, which complement each other in one semester, brings successful results. For the limited time of a month and a half between the two challenges, the results show students' improved critical thinking, taking more responsibility for their own learning, as well as intellectual maturity. Our preliminary results show that guided inquiry seems to be efficient not only for learning new tasks, but also for transferring learned skills to tasks of a greater difficulty.

References

1. Prince M. and Felder R., "The Many Faces of Inductive Teaching and Learning", *Journal of College science Teaching*, Vol.3 (5), pp.14-20, (2007).
2. Bransford, J.D., A.L. Brown, and R.R. Cocking, "How People Learn: Brain, Mind, Experience, and School", Washington, DC: National Academy Press, (2000).
3. Ramsden, P., "Learning to teaching higher Education", 2nd ed. London: Taylor and Francis, (2003).
4. Norman, G.R., and H.G. Schmidt, "The Psychological Basis of Problem-based Learning: A Review of the Evidence", *Academic Medicine* 67 (9): 557-65, (1992).
5. Coles, C.R., "Differences Between Conventional and Problem-based Curricula in their Students' Approaches to Studying", *Medical Education*, 19(4): 308-09, (1985).
6. Felder, R.M., and R. Brent, "The Intellectual Development of Science and Engineering Students. Pt. 1: Models and Challenges", Pt. 2: Teaching to promote growth. *Journal of Engineering Education* 93 (4): 269-77; 93 (4): 279-91, (2004).
7. Prince, M., and R.M. Felder, "Inductive Teaching and Learning Methods: Definitions, Comparisons, and Research Bases", *Journal of Engineering Education*, 95 (2): 123-38, (2006).
8. Bateman, W., "Open to Question: The Art of Teaching and Learning by Inquiry", San Francisco: Jossey-Bass, 1990.
9. Lee, V.S., ed., "Teaching and Learning through Inquiry", Sterling, VA: Stylus Publishing, 2004.

Appendix A: Survey Questions

<i>a result from the Device Analysis in what extent did you make gains in:</i>
Hands-on activity in analyzing a real world mechanism
Ability to clearly describe the device and its operation
Ability to describe the science and engineering principles
Ability to present data, calculations and results from the analysis
Ability to assess the design and propose possible ideas for improvements
Ability to identify additional work that is needed to refine the results
Ability to take decisions and defend them
Ability to analyze a real world mechanism
Please, share at least three questions that you were asking yourself while working on the Device Analysis
Additional Comments

Appendix B: Survey Questions

<i>a result from the Design Challenge to what extent did you make gains in:</i>
Solving real world problems without direct assistance
Working efficiently with others
Ability to think through a problem with specific constraints
Ability to develop models which help you to communicate and better understand your design ideas
Ability to assess the performance of your design, based on task objectives
Ability to identify additional work that is needed to refine your results
Ability to take decisions and defend them
Ability to analyze a real world mechanism
Please, share at least three questions that you were asking yourself while working on the Device Analysis
Additional Comments

The Decline of the Car Enthusiasts: Implications for Undergraduate Engineering Education

M. Cardenas
Harvey Mudd College, Claremont, California

Abstract

Hands-on, project-based engineering education is alive and well. However, anecdotal evidence indicates that we are seeing fewer undergraduate engineering students who arrive on campus already knowing how to ‘use their hands’—having familiarity with tools and mechanical devices, knowing how to connect things, savvy about avoiding leaks in fluid systems, wary of stripping a screw thread or shearing a bolt head—the kinds of things that an archetypal car enthusiast would have learned in high school. For design-build-test project-based engineering educational experiences, having at least one car enthusiast has proven invaluable: more time can be spent on testing and re-designing, rather than getting bogged down in the initial selection of means to satisfy an engineering design function. Also, it seems that the design space can be expanded; students are aware of more ways to satisfy design functions, and less likely to eliminate potential designs due to ignorance of building techniques. Car-enthusiast skills also come in handy during the building process, rather than relying on inexperienced students who may be picking up tools for the first time. Why the decline in these do-it-yourself-ers? Evidence shows that fewer Millennials own and drive cars. This may be affecting their experiences with car maintenance. Millennial culture also includes a type of perfectionism that may be affecting their desire to use their hands, either in fixing things, or in traditional ways of building. The existence of on-board diagnostic computer interfaces is perceived to have an effect, though it is arguable. Many gadgets, especially electronic devices such as mobile phones, PDAs, and gaming systems, are designed and manufactured in ways that make them difficult to open up and repair, but new sites such as iFixit do provide teardowns and repair manuals. I will explore these issues, especially their implications on current undergraduate engineering pedagogy, present ‘practical work’ experiences from Canterbury and Imperial College, and suggest potential ways of improving beginning engineering students’ hands-on skills.

Introduction

Car ownership was once a defining event in a young person’s life. A car might have been seen as a symbol of freedom and power (especially to those of us who grew up listening to the Beach Boys, Bob Dylan, Bruce Springsteen or Golden Earring); an indication of material wealth or status (*The Great Gatsby*); and to many budding engineers of previous generations, an aesthetically-pleasing machine that felt, smelled, and sounded good. However, to the Millennial (or Generation Y) cohort—usually defined as those born in the 1980s and 1990s—interest in cars is declining.

Many nations, including the United States, show a decline in car mobility (miles driven and ridden), car ownership, and obtaining of a driver's license. USDOT reported a leveling-off of car usage since 2005¹; R.L. Polk & Co. reported² in mid-2012 that new vehicle buyers in the age group 18-34 only accounted for 11% of all new vehicle buyers (down from 17% five years ago); total car mobility in the Netherlands has not increased since 2005, while mobility for young persons (aged 18-29) has decreased by 27%³; and BITRE⁴ reports a saturation in traffic growth in Australia and 24 other countries.

A number of reasons for the decline in car usage and ownership by members of the Millennial generation have been proposed, mainly focusing on the changes in culture caused by mobile internet, urbanization, and the economy. Cultural changes due to mobile internet are seen as a central factor: "The broad implementation of (mobile) Internet in society (e-working, e-shopping, e-commerce, use of social networks) is leading to a reduction in physical (car) mobility³." Also, in 2011, CISCO⁵ reported that two-thirds of Millennials would choose having internet access over having a car. Urbanization and changes in Millennials' attitude is believed to have led to increased use in bicycling, public transportation, and walking: "In 2009, the 16- to 34-year-old age group took 24-percent-more bike trips than in 2001, even as its population shrank by 2 percent. The same age group walked to more destinations in '09 than in '01, and the distance it traveled by public transit increased 40 percent⁶." JD Powers mentions that economic factors, such as the price of fuel and cost of car maintenance, have lessened Millennial's desires to take on the financial burden that car ownership entails⁷.

A car enthusiast, in contrast, shows great appreciation, respect, and knowledge of motor vehicles. Some characteristics of a car enthusiast are the interest and ability in performing their own car maintenance; do-it-yourself installation of aftermarket parts; and understanding the mechanics of automobiles.

Does The Millennial Car Enthusiast Exist?

The demographics show that car enthusiasts do not include a significant number of Millennials. About.com noted, "The average age of the historic vehicle hobbyist is 55. And 75% of the hobby is 46 years old or more. Social, economic and technical forces conspire to divert the interest of youths away from the automobile. If these trends are left unabated we will continue to see the hobby age, declines in the number of enthusiasts and the value of vehicles, clubs will shrink and support services will become scarcer as more enthusiasts exit the hobby than enter it⁸."

Car enthusiasts often perform their own car maintenance, and take apart and put together their cars, sometimes to perform repairs or maintenance, to install aftermarket parts, or simply to gain more understanding of the mechanics of the vehicle. In undergraduate engineering education, students with a car-enthusiast background are very valuable, especially in the context of hands-on, design-build-test projects. These car enthusiasts generally have experience with tools and their use; don't panic if they strip the threads off a screw, or torque the head off a bolt—and even better, often have the knowledge to avoid just those situations!—are familiar with fabrication techniques, and have intuition involving mechanisms that elevated designs and analyses over those of less-experienced students. Especially for capstone design projects, having a 'car guy' or 'car gal' on the team is very desirable.

Over the past five-to-ten years, I have been seeing fewer car enthusiasts in our undergraduate engineering student population. Students who have practical skills such as welding are almost nonexistent now, where five years ago there would commonly be a handful of students who could weld, and had prior machining experience. I can't fault our Admissions department, as they are quite aware of our need for students "who can use their hands", and thus Admissions looks for and prioritizes that trait, knowing how important it is for Engineering. One possibility is that there are fewer budding engineers who are also car enthusiasts.

Some might suggest that fewer undergraduate students work on their own cars because it's too difficult on modern cars, and that these cars aren't meant to be opened up, diagnosed, and repaired, especially by a DIYer. The emergence of on-board diagnostics stemming from the 1991 California Air Resources Board (CARB) requirement certainly has changed car maintenance, but a good number of car enthusiasts will claim that the existence of on-board diagnostics code readers and scan tools, rather than making DIY impossible, actually makes it easier. (Many auto parts stores will run free scans for customers, and the cost of scan tools for moderate DIY use is under \$60.) What is more likely is that the design of some vehicles has made accessibility difficult, with engine covers and undertrays needing removal before one can get to the engine, and more importantly, having less space in which to maneuver tools and hands⁹.

Research suggests that cultural changes are likely to have affected the chances of a Millennial being a DIYer car enthusiast. In addition to the mobility and ownership issues cited earlier in this paper, car leasing may have had an effect, with fewer cars being "handed down" to young adults by their parents. It's also possible that leased vehicles aren't worked on in the same way an owned vehicle is, thus causing less DIY car maintenance in general. Ted Cardenas, Vice President of Marketing in the Car Electronics Division at Pioneer Electronics, suggests that changing attitudes among Millennials is also a factor: teenagers would prefer to be "driven by their parents in the Escalade, rather than driving themselves in a beater car¹⁰." He also believes that Millennials have a perfectionist attitude that may be affecting their attitudes towards hands-on skills, describing how they might try to make something (say, laying up carbon fiber, or machining a part) exactly once, and be so disappointed in how their first try looks that they never attempt it again. He finds that Millennials are increasingly more apt to make things with 3D printing technology, although he noted that the things they print are usually not often for use on vehicles, but 'just personal stuff, objects.' Personal digital fabrication items such as these can be found on Thingiverse¹¹, and microproduction and the "democratization of manufacturing" is put forth as a "promise[s] to revolutionize the means of design, production and distribution of material goods and give rise to a new class of creators and producers¹²."

Implications for Undergraduate Engineering Education

In undergraduate engineering education, it is typical for junior and senior students to take courses involving design-build-test projects. Some of these projects can involve the construction and fabrication of mechanical systems, for example ASME's Human Powered Vehicle Challenge¹³; the American Solar Car Challenge¹⁴; and Virginia Tech's Battery Operated Land Transport¹⁵ team participating in the TTGXP Electric Motorcycle Racing series. In addition, many institutions conduct engineering design clinics¹⁶ and capstone courses¹⁷ that often involve students needing practical skills. As mentioned previously, having car enthusiasts on these

projects is a real boon, and anecdotal evidence seems to indicate that we are seeing fewer of these types of undergraduate engineering students.

It is possible to argue that undergraduate engineering students are gaining practical skills as they work on these types of projects, and therefore there is no need for concern: students are getting these skills and they will enter the workforce prepared and knowledgeable. However, what I am seeing in my team-based clinic projects is not just a slowing of progress (a good amount of time is spent learning practical skills, and extracting themselves from situations where they've broken things due to inexperience) but an actual cutting-off of entire design paths. It is not uncommon to see students choose alternative designs based on what they think they can build, and a narrowing of design space due to students not being familiar with typical mechanical devices. Faculty advisors can combat the design-space-narrowing by pointing students toward already-existing devices and solutions that might help them, but even with that level of faculty vigilance, students still seem less likely to explore those design options. For years-long projects such as design competitions, it is possible that these types of problems can be lessened or overcome, but in a 9-month-long engineering clinic (or especially in a one-semester project) design choices are made earlier, and can't be modified as easily (or at all.)

There are also changes in skills among the engineering faculty as institutions continue to prioritize scientific research and publishing over practical engineering skills and experiences. Faculty without industrial experience or practical skills may not recognize these problems in their students, or if they do, may not give it great weight, since they were successful without possessing these skills. However, some in industry are recognizing this situation: "After NASA's Jet Propulsion Lab noticed its new engineers couldn't do practical problem solving the way its retirees could, it stopped hiring those who didn't have mechanical hobbies in their youth¹⁸."

It is of great educational value for students to learn practical skills (and break—and fix!—things in the process), and thus get more intuition of how things work, but I find that we can meet design and capstone learning objectives better when undergraduate students gain practical experience in using their hands before their 3rd and 4th years. Next I will summarize two examples of undergraduate engineering education experiences for 1st-year students.

Examples of Practical Work in Undergraduate Engineering Education

At the University of Canterbury in Christchurch, New Zealand, undergraduate engineering students have a Practical Work¹⁹ requirement. This includes a 35-hour workshop, and a minimum of 800 hours working in the engineering industry. The basic workshop is where students learn the use of hand tools, drilling, milling, turning, brazing, and welding. Requirements for the 800 hours of industrial experience vary by discipline, but include items such as manual work, mechanical workshop, process plant operation, and professional practice. The description of work satisfying the 'manual work' requirement reads: "Civil labouring in the field on engineering construction; survey assistant; manual work in mining, farm or horticulture, forest or food industry. Lab work may qualify if it is routine testing or if it involves gathering information in the field. (In short, 'getting your hands dirty'.) Ensure work is relevant to degree as not all manual work is acceptable (eg farm work is acceptable for Natural Resources but not Civil)." The description for mechanical workshop skills is notable in that it requires "working in close contact with skilled mechanical engineering trades people (eg, as a fitters mate involved in

Proceedings of the 2013 American Society for Engineering Education Pacific Southwest Conference

Copyright © 2013, American Society for Engineering Education

plant maintenance, or where they help machine tool operators and trades people involved in metal forming, welding or foundry processes)¹⁹”, thus ensuring that the engineering student gains valuable practical skills experience from practitioners in the field. The Canterbury basic workshop must be completed before the undergraduate engineering student enters their 2nd year, thus giving them practical experience early on.

Imperial College in London, England, also has a 1st-year mechanical workshop requirement²⁰. This workshop introduces students to machine elements, and the manufacture of metal, composites, and polymer-based products. Machine element topics include introductions to bearings, gears, and power transmission. The manufacturing segment includes manual and CNC methods in turning, milling, and profiling; hole making and thread production; forging, casting, moulding; mechanical assembly; fasteners and connectors; welding; brazing and soldering; and “Practical hand prototyping and its application to conceptual design development; external turning; internal turning; milling; drilling and threads; sheet working; dismantling an assembly²⁰.”

There are also offerings for middle school and high school students, often associated with a university engineering school. Techsplorers²¹ is an example of a summer program for middle school and high school students. Techsplorers is associated with the Burroughs-Wellcome-funded Techtronics²² program of the Duke University Pratt School of Engineering. Techsplorers offers workshops where kids learn to take apart (and put back together) a lawnmower engine, and an entire motorcycle, including the engine. Tech Academy²³ of Silicon Valley is associated with San Jose State and Santa Clara University, and offers a “hands-on & high tech” course for middle school kids, inspired by “by hands-on childhood experiences—whether working on farms and repairing water pumps, tractors and machinery, or in more urban settings, tinkering with mechanical objects and cars and building crystal radios²⁴.”

I find the idea of taking motor vehicles apart and learning to use tools and make machinery to be exciting and useful, and grew up working on cars alongside my father, and with various peers throughout high school and university. Some of my fondest memories include fixing various vehicles, and then, of course, taking the test drive after putting things back together, but I was born well before the Millennial generation, and grew up in a different culture. What might Millennials respond to, in order to gain practical skills?

iFixit²⁵ is a website that provides repair manuals and teardown documentation for various consumer electronics and gadgets. They also sell toolkits and repair parts appropriate for these devices. Although many Millennials treat their devices as disposable, it is possible that budding engineering students might respond to educational experiences involving repair or teardown of their electronic devices. Although this will not give them experience with larger machinery and tools, it may help students develop more intuition into how devices work and are put together. Given the transportation literature pointing out that Millennials are increasingly using bicycles for transportation, courses involving bicycle design and maintenance may also be of interest. Stanford offers an upper division engineering technical elective in bicycle frame design/fabrication course²⁶, which, although it doesn’t solve the problem of teaching students practice skills before their capstone courses, looks to be a very engaging and useful course for Millennial engineering students.

3D printing²⁷ and “fab labs²⁸” are being used as engineering outreach for young kids; like iFixit, these offerings are likely currently restricted to smaller devices and gadgets, but again, may be of more interest to the Millennial generation. Fab Lab course offerings describe the use of desktop milling machines, and basic CNC router wood engraving.

Summary

The Millennial, or Generation Y cohort, are less likely to drive, own their own cars, and thus, tend not to be car enthusiasts who have practical experience in performing car maintenance and understanding the mechanics of vehicles. They also seem likely to have less experience with using their hands, and knowing how to use tools and shop machinery. This has deleterious effects when these students reach their 3rd and 4th year engineering design experiences, not only in slowing down progress when it comes to building prototypes or proofs-of-concept, but in narrowing the design space, and restricting design choices to those that the students feel comfortable in building. Practical Work experience can be gained by undergraduate students before they reach the upper-level courses; examples from Canterbury and Imperial College were presented. Further work in exploring culturally-appropriate Millennial options, such as work with personal electronics devices and gadgets, fab labs, and 3D printing, may be of use in engaging this generation in more hands-on learning.

Bibliography

- 1) USDOT, Traffic Volume Trends, U.S. Department of Transportation, 2010, retrieved January 10, 2013 from www.fhwa.dot.gov/ohim/tvtw/10aprtvt/10aprtvt.pdf
- 2) T. Libbey, Young Buyers Are Few and Far Between, June 21, 2013, retrieved January 10, 2013 from <http://blog.polk.com/blog/blog-posts-by-tom-libby/young-buyers-are-few-and-far-between>
- 3) Jan Van Der Waard, Ben Immers, and Peter Jorritsma, New drivers in mobility: What moves the Dutch in 2012 and beyond? Discussion Paper No. 2012-15, Prepared for the Roundtable on Long-Run Trends in Travel Demand, 29-30 November 2012.
- 4) BITRE, Traffic Growth: Modelling a Global Phenomenon, Report 128, retrieved on January 10, 2013 from http://www.bitre.gov.au/publications/2012/files/report_128.pdf
- 5) CISCO. Cisco. (2011). Cisco Connected World Technology Report. The Future of Work: Information Access Expectations, Demands, and Behavior of the World's Next-Generation Workforce. San Jose: USA. Denstadli, J.M., Julsrud, T.E. & Hjortol, R.J. (2012). Videoconferencing
- 6) Todd Lassa, Why Young People are Driving Less: Is the Automobile Over? Motor Trend, August, 2012, retrieved on January 8, 2013 from http://www.motortrend.com/features/auto_news/2012/1208_why_young_people_are_driving_less/
- 7) J.D. Power and Associates Press Release, October, 2009, retrieved on January 8, 2013 from <http://businesscenter.jdpower.com/news/pressrelease.aspx?ID=2009226>
- 8) Top Threats to the Classic Car Hobby, retrieved on January 8, 2013 from <http://classiccars.about.com/od/owningaclassic/a/Top-Threats-To-The-Classic-Car-Hobby.htm>
- 9) DIY car servicing: is it still possible? Retrieved on January 8, 2013 from <http://www.telegraph.co.uk/motoring/caraccessories/9354955/DIY-car-servicing-is-it-still-possible.html>
- 10) Personal communication, December 24, 2012.

- 11) Thingiverse, retrieved on January 8, 2013 from <http://www.thingiverse.com/>
- 12) Catarina Mota, The rise of personal fabrication, Proceedings of the 8th ACM conference on Creativity and Cognition, pp. 279-288, ACM, New York, NY, USA 2011
- 13) Human Powered Vehicle Challenge, retrieved on January 10, 2013 from <http://www.asme.org/events/competitions/human-powered-vehicle-challenge-%28hpvc%29>
- 14) American Solar Challenge, retrieved on January 10, 2013 from <http://americansolarchallenge.org/>
- 15) Bolt Electric Motorcycle, retrieved on January 10, 2013 from <http://www.bolt.org.vt.edu/>
- 16) Bright, A., & Phillips, J. R. (1999). The Harvey Mudd Engineering Clinic Past, Present, Future. Journal of Engineering Education, 88(2), 189-194.
- 17) Dutson, A. J., Todd, R. H., Magleby, S. P., & Sorensen, C. D., A review of literature on teaching engineering design through project-oriented capstone courses, Journal of Engineering Education, 86, 17-28, 1997.
- 18) Why Your Teenager Can't Use a Hammer, retrieved on January 10, 2013 from <http://www2.macleans.ca/2011/08/25/why-your-teenager-cant-use-a-hammer/>
- 19) Introduction to Practical Work Experience, retrieved on January 8, 2013 from <http://www.engf.canterbury.ac.nz/practical/>
- 20) ME1-HDMF-Design and Manufacture, retrieved on January 8, 2013 from <http://www3.imperial.ac.uk/mechanicalengineering/study/subjects/year1/me1hdmf>
- 21) Techsplorers, retrieved on January 10, 2013 from <http://www.techsplorers.com/index.html>
- 22) TECHTRONICS: HANDS-ON EXPLORATION OF TECHNOLOGY IN EVERYDAY LIFE by Paul A. Klenk, Gary A. Ybarra, Rodger D. Dalton. Proceedings of the 2004 American Society for Engineering Education Annual Conference & Exposition Copyright © 2004, American Society for Engineering Education
- 23) Tech Academy Background, retrieved on January 10, 2013 from <http://techacademysv.com/background.html>
- 24) Tech Academy Hands On & High Tech, retrieved on January 10, 2013 from <http://techacademysv.com/hands-hightech.html>
- 25) Ifixit.com, retrieved on January 14, 2013 from <http://www.ifixit.com/>
- 26) ME 204, Bicycle Design and Frame Building, retrieved on January 14, 2013 from <http://www.pureirishstout.com/ClassInfo.html>
- 27) Inspiring next gen inventors: teens, engineering education and 3D printing, retrieved on January 13, 2013 from <http://triplehelixinnovation.com/inspiring-next-gen-inventors-teens-engineering-education-and-3d-printing/2234>
- 28) FAB LAB at Fox Valley Technical College, retrieved on January 14, 2013 from <http://www.fvtc.edu/public/content.aspx?ID=1873&PID=1>

Inquiry-Based Learning Activities in Dynamics

Jeffrey Georgette, Brian Self, James Widmann, Kathryn Bohn, Eric Wang*
California Polytechnic State University, San Luis Obispo/*University of Nevada, Reno

Abstract

The Inquiry-Based Learning Activity (IBLA) method was implemented in an undergraduate dynamics class to improve conceptual understanding. This was done through a rolling objects activity, in order to present students with the concepts of moment-of-inertia and work-energy. Students were evaluated with a Dynamics Concept Inventory (DCI), a quiz, a hands-on activity, and a final exam question. These activities were analyzed by the professor and teaching assistants to gain insight into student thinking and improve course outcomes and student learning success. Two implementations will be discussed: (a) a full IBLA where teams of 4-5 students manipulate the different objects, and (b) a demonstration mode in front of a class of 60 students.

Introduction

Students in higher education strive towards improving their factual knowledge, conceptual understanding, problem solving skills, and attitudes. Some argue that conceptual understanding is the most meaningful component among student effort. Educators have worked towards promoting conceptual understanding in the realm of college physics¹ and mathematics, although more work can be implemented in the engineering to realize learning gains. Student success can include conceptual understanding and pragmatic outcomes like increased knowledge and retention in programs². Understanding concepts leads to growth throughout higher education, so care must be taken to guide the correct understanding of course material. If the student is to learn the course material, he/she must understand the fundamentals and be able to apply them in future contexts.

Active learning is used as a method to reach such aims. Student activity and engagement are key elements of active learning². This contrasts with traditional lecture formats, where students passively receive information from the professor. Through inquiry based learning, students can actively engage by performing experiments and by learning in teams.

The reason for this study is to help students gain a greater understanding of dynamics concepts. Learning Dynamics requires mastering concepts, not simply memorizing facts or equations. Specifically, the concepts focused on in this study are moment-of-inertia and work-energy, which are essential to the course. Engineering concepts in Dynamics are not always intuitive to

Proceedings of the 2013 American Society for Engineering Education Pacific Southwest Conference

Copyright © 2013, American Society for Engineering Education

the student; since they cannot touch “energy” or feel “work” physically. Mass moment-of-inertia about a rotating axis not very intuitive, compared to mass translational inertia. Students often do not understand that bodies have both translational and rotational-kinetic energy. Unfortunately, students bring misconception into the learning environment and these must be worked on, to succeed in the future. According to the National Research Council, students can “parrot” answers on a test, repeating back phrases from lecture, and conceal their misconceptions, which may resurface weeks or months later³. These misconceptions must be addressed and corrected.

Work has been done in other science disciplines concerning conceptual understanding. In a study involving 6,000 students, Hake⁴ showed that instruction that involved active learning and that emphasizing conceptual understanding resulted in much larger conceptual gains than traditional lecture-based approaches.

Students can work towards understanding such concepts through inquiry-based learning activities. The rolling objects IBLA was developed for a dynamics course for undergraduate engineers at Cal Poly San Luis Obispo, CA during fall 2012. We will also compare the IBLA results to the results from a demonstration-based activity in a large classroom at the University of Nevada, Reno.

Background

The purpose of an IBLA is to help students learn through inquiry and engagement by having reality act as the ‘authority’ instead of just the word of the professor. The professor can tell the students why something happens or will happen but this may not be as effective as letting the results of the physical experiment communicate the information. The IBLA method calls for students making a prediction of a physical situation followed by witnessing the result and reaching conclusions - similar to the scientific method. The students run their own experiments and thus take ownership of the learning process.

As shown in Figure 1, Laws et al.¹ show that using inquiry-based active learning instruction dramatically increases student performance on questions relating to force, acceleration, and velocity.

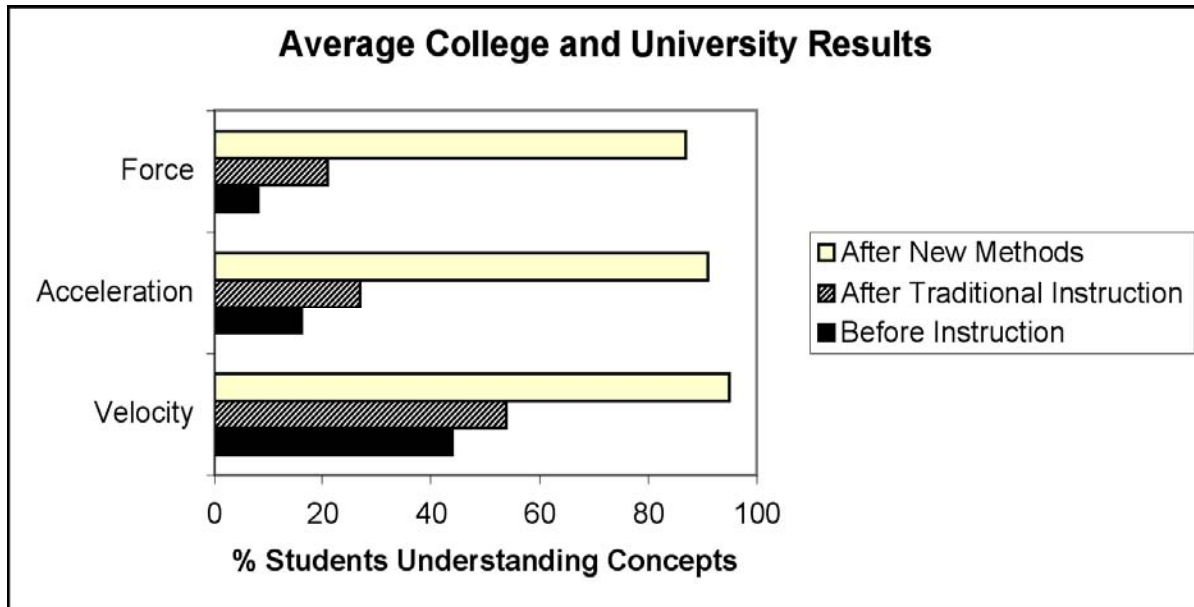

Figure 1. Active-engagement vs. traditional instruction for improving students’ conceptual understanding of basic physics concepts (taken from Laws et al.,¹).

Although the exact definition of inquiry-based instruction varies somewhat between different investigators, we will use the defining features offered by Laws et al.¹ and highlighted by Prince and Vigeant⁵.

Table 1: Elements of Inquiry-Based Activity Modules

- (a) Use peer instruction and collaborative work
- (b) Use activity-based guided-inquiry curricular materials
- (c) Use a learning cycle beginning with predictions
- (d) Emphasize conceptual understanding
- (e) Let the physical world be the authority
- (f) Evaluate student understanding
- (g) Make appropriate use of technology
- (h) Begin with the specific and move to the general

Implementing the IBLA

A hands-on experiment was used as the vehicle for implementing inquiry-based learning in the classroom. Students worked towards improving their conceptual understanding of rolling objects, including work-energy and mass moment of inertia. The students rolled objects down an inclined ramp and witnessed the behavior of objects with different masses, radii, and form (solid cylinder or pipe). The first object to finish the downhill race had the largest translational speed at the bottom of the ramp. The student teams rolled six different objects, with the form of either cylinder or hoop, and made of wood, PVC, aluminum, or steel (see Appendix F for a parts list), as seen in Figure 2.



Figure 2. The Cylinder/Pipe IBLA.

As the students performed the experiments they filled out a worksheet (found in Appendix B). The students made a prediction before the test, recorded the results, and explained their conceptual understanding as they progressed. Through the worksheet, students confronted their predictions and later were able to create informed conclusions.

During the lab experience, the professor and teaching assistants oversee the activity alongside the undergraduate students. They are able to aid the students, ask them thought-provoking questions, and guide them towards the correct conceptual understandings in Dynamics. For example, if the students roll a given set of objects and had inconsistent results, the assistants would have them repeat the roll a few more times to make sure the correct conclusion was reached.

The Cylinder-Pipe IBLA addresses the effects of distribution of mass with the first exercise (big metal solid cylinder and the black metal pipe with same radius, length, and mass). The IBLA then goes on to explore different concepts of work and energy. This demonstrates to students that as long as there is rolling without slip, all solid homogeneous cylinders will have the same linear velocity at the end of the ramp, *independent of mass and radius*. Furthermore, all cylinders will always get to the bottom of the ramp before all pipes, regardless of the radius and mass. This is demonstrated by examining the work-energy equation: $T_1 + V_1 = T_2 + V_2$, where T and V are kinetic and potential energy, respectively. If the cylinder starts from rest, then $T_1 = 0$.

For a given ramp, the change in height will be same for all circular objects. Therefore, we can rewrite the equation as:

$$mgh = \frac{1}{2} I_G \omega^2 + \frac{1}{2} m v_G^2 \quad (1)$$

We now set the mass moment of inertia equal to cmr^2 , where c is a scaling factor. For a thin ring, $c = 1$, and for a solid cylinder, $c = 1/2$. If we also substitute the roll without slip condition, $v_G = r\omega$, we obtain:

$$mgh = \frac{1}{2} cmr^2 \left(\frac{v_G^2}{r^2} \right) + \frac{1}{2} m v_G^2 \quad (2)$$

Solving for v_G , we see that the mass and the radius both cancel.

$$v = \sqrt{\frac{2gh}{1+c}} \quad (3)$$

Examining Eq (3), it can be seen that the linear velocity only depends on the mass moment of inertia factor, c . Therefore, a round object with a higher mass moment of inertia will get to the bottom of the ramp more slowly than an object with a smaller I_G . Many students realized that this really indicates a distribution of the translational and rotational kinetic energy of the objects. A cylinder will have greater translational energy than a pipe of identical radius and mass when released from identical locations on the ramp, and therefore will reach the bottom fastest.

Finally, after the IBLA a homework problem (see Appendix D) was assigned that asked the students to prove that a solid cylinder will always beat a pipe. This was followed by a problem where students use the work-energy equation to calculate velocities for a pipe, cylinder, and sphere at the bottom of a ramp.

Implementing the Rolling Objects Demonstration

At the University of Nevada, Reno (UNR) dynamics is a semester-long course taught in a traditional large, lecture style format (90-100 student is typical). In an effort to repair misconceptions concerning inertia, an in-class demonstration is conducted that lasts one full lecture period (50 minutes).

Personal response devices (a.k.a. “clickers”) are used daily to enhance student involvement. For this study, the clicker responses were used in lieu of a pre-test. It must be noted that students are allowed to discuss the question posed before answering, which confounds the results.

When prompted (via a PowerPoint slide) whether an aluminum or steel solid cylinder would have a higher speed at the bottom of a ramp, 37.4% of students indicated steel, 40.7% indicated aluminum, and 22.2% indicated they would have the same speed.

Likewise, when asked whether an aluminum cylinder or aluminum hoop would have a higher speed at the bottom of a ramp, 58.1% students chose the cylinder, 31.1% chose the hoop and, 10.8% indicated they would have the same speed.

After the initial questions were posed, the rest of the class period was devoted to demonstrating how different objects behaved as they rolled down a ramp. The equations discussed above were also covered followed by more demonstrations using cylinders and hoops with varying mass, radii and inertia.

Results

Table 2 shows (a) the pre- and post-DCI results of the rolling objects question, (b) the quiz results from the day before the IBLA, and (c) the results from the final exam question.

Table 2. Assessment of Cylinder IBLA and the Rolling Objects Demonstration: percentage of students answering the question correctly.

	DCI (Appendix)		Quiz (pre-IBLA) (Appendix)	Exam (Appendix)
	Pre	Post		
IBLA	31.3%	89.8%	43.4%	84.5%
Demo	58.1%	55.7%		

Students were tested on Dynamics concepts on an activity worksheet, the tally of coded responses can be seen in Table 3. Worksheet responses were broken up into an assortment of labels on the left hand column which were demonstrative of the concepts relating to moment-of-inertia and work-energy. The right column lists the percentage of students groups who reported the concept or statement.

Table 3. Categorizing student in-class worksheet responses

Concept or Statement written explicitly on worksheet by	Percent per student group out of total student groups
Moment of Inertia based upon mass distribution	38.8%
Moment of Inertia relates to rolling acceleration or translating velocity	67.4%
Potential Energy at top of ramp converts to Kinetic Energy at the bottom of ramp	75.5%
Kinetic energy distributes into linear and angular components	44.9%
Work-Energy equation	59.2%
Solid cylinders beat hoops, down ramp	2.1%
Either solid cylinders or pipes: roll with the same translational velocity	22.5%

The most stated concept was the conversion from potential to kinetic energy (75.5%); while the least stated concept by students was that solid cylinders beat hoops down the ramp (2.1%).

Subjective Assessment

Students were asked a number of questions on an end-of-course survey. They were able to express their opinions and rate course content. The first set of questions used a Likert scale to determine (a) if different course components helped the students learn the material and (b) students thought it was interesting and motivating. Averages for the responses are shown in Table 4, where 1= strongly disagree, 2= disagree, 3= neutral, 4= agree, and 5= strongly agree.

Table 4. Results from end of the course survey

The Cylinder/Pipe IBLA helped me learn the material.	The Cylinder/Pipe IBLA was interesting and motivating
4.38	4.12

Additionally, they were asked “When did the behavior of the different rolling cylinders finally make sense to you (e.g., in the middle of the activity, after talking to your team about it, after it was discussed in class, when you took the quiz, after you saw the quiz solution, it still doesn’t

make sense...)?”. Responses were coded and are tabulated in Table 5, helps the professor to pinpoint when the students experienced the “aha” moment and understood the course concepts.

Table 5. Student responses as to when they understood the concepts in the IBLA.

Concept	Quantity of response
Understood beforehand	10
During/after quiz	2
During activity	52
Talking with team	36
After activity	7
Discussion in class	19
Studying it later	11
After homework	22
Still confused	7

Video footage was taken to witness student learning progress during the activity. Through the recordings, we could investigate students’ justifications and thought processes while answering the different prompts.

From the video footage one group of students began to see a trend in the outcomes. For example, one student reported that “mass and radius did not affect rolling behavior.” Furthermore, by the end of the worksheet they started to make the correct predictions, such that “all pipes would roll the same.” One group compared the gravity force from a large cylinder to the large moment of inertia it possessed. One group mentioned, “Gravity force gets bigger with cylinder/pipe mass, but longer to accelerate.” One group stated their “predictions were wrong”, which shows they were perceptive of their previously held misconceptions, which can later be repaired with the correct conclusions. Most groups managed to stayed on task - usually one person in the group acted as the writer, while another acted as the lead “roller.”

One misconception was that the ratio of two objects’ moments of inertia was equivalent to the ratio of their radius or the ratio of their mass. This was written as a justification for predictions of the rolling behavior of two solid cylinders of different radius and mass (for example, some guessed that the hollow pipe would beat the solid cylinder). Some groups felt the time crunch and sought to finish the activity quickly and write something down in paper, even if they were not fully sure of their results

Discussion of the results

The main focus of this study was to impart conceptual understanding and repair misconceptions from Dynamics. From the results, more than 80% of the students answered the post-DCI question and final exam correctly, while the average quiz score was around 40%.

Through the hands-on activity the majority of students reached correct conclusions from the rolling behavior of the objects. Unfortunately, a small difference in the starting position can change the final outcome so that two solid cylinders may not reach the bottom of the ramp at exactly the same time. Interestingly, students will cling to their previously held misconceptions even if there is only a slight difference in velocities at the bottom (e.g., a steel cylinder just barely beats a wooden cylinder). To minimize starting effects, we recommend a shallow ramp angle (see Figure 2) and the construction of some type of starting gate,

From the coded responses in table 2, understanding of the lower percentage scoring areas (example: solid cylinders always beat hoops down ramp) could be improved through new methods or more effort in current methods. Although moment-of-inertia is an important concept it was only shown by 38% in student's worksheet responses, there is room for improvement. Another concept, work-energy equation, an important dynamics relationship, was stated on 59.2% of group worksheets. Both of these topics were covered on the follow-up homework assignment. Emphasis could be added to promote such concepts and steer the student in the right direction towards the right answer. This could be done by a question explicitly probing this idea or by more coaching to direct the student. Such questions would elicit students' held misconceptions, which can then be repaired.

It is unclear if the students' explicit responses represent their true understanding. Perhaps only a minority of the group decided what to write down, and understanding could be deeper than what was written on the worksheets. Perhaps the format of the worksheet influenced learning outcomes. For example, some of the concepts were asked for explicitly in the question prompt, while others were not. We hoped that the students would reach the right conclusion for each prompt and think critically.

From the survey represented in table 5, performing the physical activity proved to be a significant influence in understanding of the subject (52 responses) as well as talking with teammates (36 responses). One teaching assistant noted when students had others to collaborate with, they did well. Survey comments show that student understanding grew because of the activity.

A starter gate will be constructed. Also the worksheet will be modified to emphasize topics that were not understood as well as others. This will be implemented on future iterations of the activity in upcoming classes.

Comparison of IBLA to monstration

*Proceedings of the 2013 American Society for Engineering Education Pacific Southwest Conference
Copyright © 2013, American Society for Engineering Education*

As can be seen in Table 2, the students who participated in the IBLA scored considerably higher on the DCI post question (Appendix A) than those who witnessed the demonstration. Although this cannot be attributed totally to the IBLA, it does suggest that active participation in the activity and continued testing and discussion of different rolling objects may have a large effect on student understanding. The follow-on homework assignment may also play a large role in the outcome – asking students to make calculations after doing the physical activity could have strongly reinforced the IBLA. A comparison of the IBLA and demonstration mode certainly bears additional investigation.

Conclusions

The first implementation of the IBLA was largely successful. The students found the activity motivational and helpful to their learning. Student scores on a relevant DCI question were nearly three times higher than at the beginning of the course, and 44% higher than a control group where a similar demonstration was provided. The IBLA forced students to make predictions, directly confront their misconceptions, and formulate new conceptual frameworks to explain the behavior of the rolling objects. It is hypothesized that the follow-on homework assignment helped to solidify this new conceptual framework and improved student understanding of mass moments of inertia and the principles of work and energy.

Acknowledgements: Support for this work was funded by the National Science Foundation, NSF 1044282, Using Inquiry-Based Activities to Repair Student Misconceptions in Engineering Dynamics. Any opinions, findings, and conclusions or recommendations expressed in this material are those of the author(s) and do not necessarily reflect the views of the National Science Foundation.

Bibliography

1. Laws, P., D. Sokoloff, and R. Thornton, Promoting Active Learning Using the Results of Physics Education Research. UniServe Science News, 1999. 13.
2. Prince, M. (2004) Does Active Learning Work: A Review of the Literature. Journal of Engineering Education, pp 223-231.
3. Bransford, J., A. Brown, and R. Cocking, How People Learn: Body, Mind, Experience and School. 2000, Commission on Behavioral and Social Science and Education, National Research Council: Washington, D.C.
4. Hake, R., Interactive-Engagement vs. Traditional Methods: A Six-Thousand-Student Survey of Mechanics Test Data for Introductory Physics Courses. American Journal of Physics, 1998. 66(1): p. 64-74.
5. Prince, M. and Vigeant, M. (2006) Using Inquiry-Based Activities to Promote Understanding of Critical Engineering Concepts. Proceedings, American Society for Engineering Education Annual Conference and Exposition.

Appendix A: DCI Question

The two objects in the figure at the right are released from rest at the position shown and roll without slipping down identical hills. Both objects have the same mass m and same outer radius. Object A is a thin hoop whose mass is concentrated in its outer edge. Object B is a uniform solid cylinder. Neglecting air resistance, how do the speeds of the two objects compare when they reach the bottom of their respective hills?

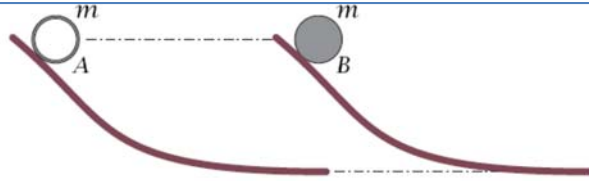

- (a) A and B will have the same speed.
- (b) The speed of A will be greater than that of B .
- (c) The speed of B will be greater than that of A .
- (d) Knowledge of the friction forces is required to answer the question.
- (e) Knowledge of the shape of the cross-section of the thin hoop is required to answer the question.

Appendix B: Cylinder-Pipe IBLA Worksheet

Cylinder vs Pipe Laboratory

Setup

Create an incline with the ramp with a height of several inches using a book or steps.

Experiment

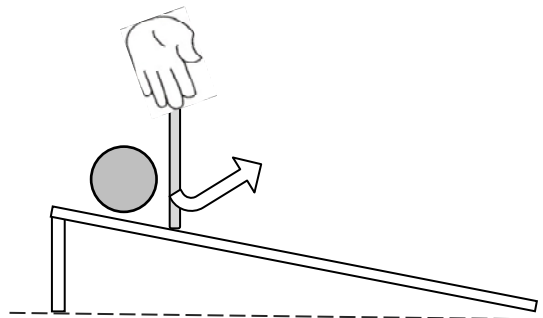

Place the rolling objects close to the top of the ramp and side by side. Create a ‘starting gate’ with the clipboard. To initiate the race, flip up the clipboard with both hands. When the objects roll to the bottom of the ramp catch them or use a cushion to stop them. Run the following scenarios and respond to the prompts.

*Proceedings of the 2013 American Society for Engineering Education Pacific Southwest Conference
Copyright © 2013, American Society for Engineering Education*

Exercises

- Roll the **big metal solid cylinder** and the **black metal pipe**. (Same radius, length, and mass). State your prediction. State the post-race result. How do you explain the race result using principles of Dynamics?
- Next, roll the **small metal solid cylinder** and the **wood solid cylinder**. (Same radius and length, but different mass). State your prediction and state the post-race result. How does mass influence rolling behavior?
- Roll the **big metal solid cylinder** and **wood solid cylinder**. (Same length and shape, different mass and radius). State your prediction and state the post-race result. How do the cylinders compare to each other?
- Roll the **small PVC pipe** and **big PVC pipe** and **grey metal pipe**. (Same length and shape, different radius and mass). State your prediction and state the post-race result. What is the rolling behavior of pipes?
- Which has bigger Kinetic Energy when it reaches the bottom, the *big metal solid cylinder* or *black metal pipe*? (same mass and radius)
- Which has bigger Kinetic Energy when it reaches the bottom, the small metal solid cylinder or the wood solid cylinder, or big metal solid cylinder?

Appendix C: Quiz Question Before the Cylinder/Pipe IBLA



In the picture above, the cylinder (A) and the pipe (B) above have the same outer radius and the same mass. If they are released from rest and roll without slipping down identical ramps, which of the following statements is true?

- a) The cylinder A will get to the bottom of the ramp first
- b) The pipe B will get to the bottom of the ramp first
- c) The cylinder A and the pipe B will get to the bottom of the ramp at the same time
- d) There is not enough information to tell

Appendix D: Homework Due After the Cylinder/Pipe IBLA

1. Use the Work-Energy Equation to show that a cylinder will always reach the bottom of the ramp faster than a pipe with a small thickness, *independent of mass or radius*.
2. A homogeneous sphere S, a uniform cylinder C, and a thin pipe P are each released from rest on the incline shown. Knowing that all three objects roll without slipping. Each has the same outer radius of 10 cm and the same mass of 1 kg. After rolling for 3 meters, calculate the linear velocity of each rolling object.

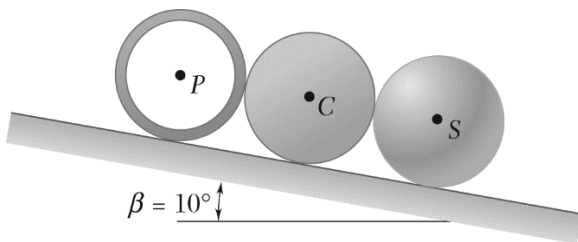

Appendix E: Final Exam Problem Assessing the Cylinder/Pipe IBLA

The thin disk (a) and ring (b) both have the same mass and radius. They are both released from rest in the horizontal position shown. Which will have the higher angular acceleration when they are released?

- The thin disk (a) will have the higher angular acceleration
- The ring (b) will have the higher angular acceleration
- The disk and ring will have the same angular accelerations
- Not enough information to tell



Appendix F: Activity parts list

Big solid aluminum cylinder	Outside radius: 1.75 inch	Mass: 2.7 pound	Length: 2.9 inch	Aluminum 6061	McMaster: 8974K89
Small solid aluminum cylinder	Outside radius: 2 inch		Length: 3 inch	Aluminum	Metal supply
Black metal pipe	Outside radius 1.75 inch, inside radius 1.45 inch. Wall thickness: 0.3 inch	Mass: 2.7 pound	Length: 3.15 inch	Steel unthreaded pipe size 3	McMaster: 7972K322
Grey stainless steel pipe				PVC	Scrap
Large PVC pipe	Outside radius: 6.25 inch		Length: 3 inch	PVC	Home depot
Small PVC pipe	Outside radius: 2 inch		Length: 3 inch	PVC	Home depot
Wood solid cylinder	Outside radius: 2 inch		Length: 3 inch	wood	Home depot

Implementation of a Proactive and Effective Advising Program in a Large Civil Engineering Program In the Face of Budgetary and Organizational Constraints

Seema C. Shah-Fairbank, William Kitch and Kenneth Lamb
Civil Engineering Department, California State Polytechnic University, Pomona,
CA

Abstract

Assessment data from a senior exit survey in 2009 indicated significant dissatisfaction with the advising received at a large regional university. At the time the civil engineering program had over 1500 undergraduate students and only 16 full-time faculty members, resulting in a student to faculty ratio of 90:1. A review of the existing department advising program and retention data indicated the greatest short coming was in early advising of first year students. Training of all existing advisors on the specific needs of first year students proved unsuccessful in improving first year advising. An informal survey of faculty indicated a disinterest among the majority of faculty in learning the special issues freshmen and first year transfer students face. Both budgetary and work role constraints inhibited the program from adopting techniques such as hiring dedicated lower division advising staff. Cognizant of the existing structural constraints, a three phased approach was designed to address the advising needs of students throughout their academic careers. The first phase, implemented in winter of 2011 was to provide group advising sessions where consistent and targeted guidance was provided to all students according to their academic standing. The second phase of implementation started in the fall of 2012 and employed a dedicated group of advisor for entering freshmen and transfer students. This group of advisors was selected for their interest and willingness to advise first year students (freshman and transfer). They received special training in advising of these students. The third phase, yet to be implemented, is a dedicated advising group for at-risk students (overall GPA below 2.2). Preliminary assessment data from spring 2012 indicate a significant improvement in the advising, measured by student exit surveys. This paper presents the specific advising program implemented and how organizational and structural constraints were overcome.

Introduction

Higher retention rates have been linked to early advising. When students are provided with the appropriate resources at the university they have a tendency to have a higher level of success¹. As the civil engineering (CE) department at California State Polytechnic University Pomona (Cal Poly Pomona) was preparing for their periodic ABET visit an analysis of the senior exit survey determined that students felt the faculty did not provide enough advising (refer to the results section of this paper for further details).

There were many factors that influenced their response. Enrollment with the CE department is quite high. The most recent data (2010) on enrollment numbers were compiled from the Engineering Workforce Commission. The Civil Engineering (CE) program at Cal Poly Pomona is the largest undergraduate CE department in the nation, as shown on Table 1².

Table 1: Enrollment numbers for the top ten largest Civil Engineering programs in the U.S.

School	No. Enrolled
Cal Poly-Pomona	1148
U Puerto Rico	948
Texas A&M University	945
U Illinois-Urbana Champagne	803
U Cal-Davis	671
U Florida	669
Cal Poly-San Luis Obispo	649
Virginia Poly Institute	638
Purdue University	629
NC State Univ-Raleigh	609

Starting in the fall of 2009 the CE department at Cal Poly Pomona changed from open enrollment to selective enrollment (i.e. impaction). This gave the department more control over the number of students admitted into the program and has allowed the department to steadily reduce the number of undergraduate students. Figure 1 provides a graph of active and enrolled students per academic quarter from fall 2009 to winter 2013. Active students include students that have decided not to enroll in classes for a given quarter but are still part of the department, while enrolled students are taking courses within the university.

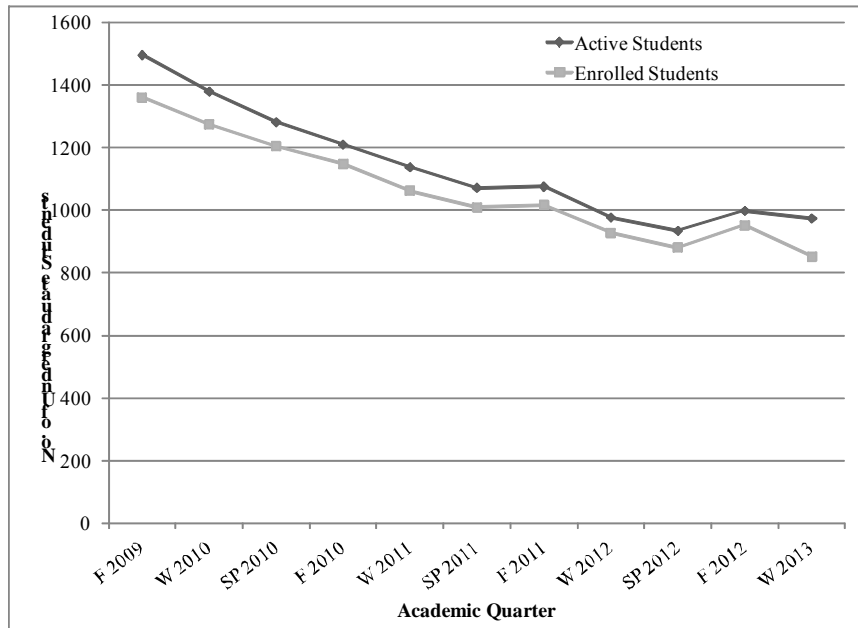

Figure 1 –Active and Enrolled Students from Fall 2009 to Current

The ultimate goal is to bring undergraduate student enrollment to approximately 950. During the same time period, the CE department was able to secure additional tenure track faculty positions and increased the number of tenure and tenure track faculty to 18. The decreased student body and increased faculty reduced the student to faculty ratio to a more manageable level. However the number of students and the variety of advising needs (academic vs. personal; at-risk vs. honors students) still puts a heavy advising load on the faculty. Part of the challenge rises from the mix of traditional and non-traditional students. Significant portions of the Cal Poly Pomona’s student body are employed for more than 35 hours per week, attend school part-time, or care for dependents. The ability to provide individualized general student advising continues to be a challenge.

Teaching loads at the university are high. Most full-time faculty teach 3 to 4 courses each term. Budgetary challenges have increased class size by approximately 25%. The large teaching load requires significant faculty time, not only in the classroom, but outside the classroom for course assessment, development, and so forth. Many faculty members had little time to devote to advising and keep up with the number of students enrolled in their courses. Thus the typical faculty member was able to offer only reactive and prescriptive advising³. This approach did not provide students with the individual attention needed to meet their specific needs, whether it include study skills, curricular advice, career planning or referrals to a student support program.

Research by Pardee⁴ noted that most students expect a prescriptive approach to advising, however, others pointed out that simply advising student to address the current crises is too narrow a focus and leaves the student vulnerable to future crises^{5,6}. Other studies have shown that quality advising can improve both student retention⁷ and performance.

A number of faculties within the university recognized both the need for quality advising and the ineffectiveness of many department-based advising programs. In response, the

University and College of Engineering created a number of ad hoc advising functions to assist students with specific needs. These ad hoc functions proliferated to the point that a freshman might be advised by as many as 6 different offices on campus during their first year. They are often intrusive in nature, forcing students to attend special advising sessions before being allowed to register for courses. More importantly, the facilitators of these advising functions were not part of the civil engineering program and thus could not provide students with coherent advising appropriate to the curriculum. During the 2011-2012 academic year the CE department established a committee to develop a single integrated department advising program.

Methodology

The department advising committee developed a three part advising improvement plan. The goal of the first stage was to provide essential prescriptive advising to ensure a consistent and effective message. This was accomplished through a group advising program. The effectiveness of this program was discussed in an earlier paper⁸. The second stage, reported in this paper, provides focused faculty advising by creating specialized advising teams. Prior to implementation, each team was trained to help students in a particular phase of the students' academic career. The final stage, still to be implemented, is to provide guided advise to at risk students (those with a GPA below 2.2)

Second Stage Overview

Prior to the spring of 2012 the civil engineering program assigned each student to an advisor without regard to the student's class standing or the faculty member's interests or skills. All tenured and tenure track faculty were required to be advisors. Each adviser was expected to provide the student with all the needed guidance in learning skills, campus resources, curriculum, career planning, graduate school planning, and anything else required. Additionally, recent faculty turnover (due to retirements and new hires) required the department to reassign advisors every year. Many students seemed frustrated due to the lack of consistency in advisors and responded by choosing not to visit their adviser.

Advising was mandatory only for students who were part of the Kellogg Honors College (KHC), 4-year Pledge Program, students classified as being at-risk or on academic probation (GPA below 2.2). A single faculty member within the CE department was responsible for all KHC and 4-year pledge student's prior to the 2010 academic year. The number of students these two programs contain grew considerably since that time (See Figure 2). This was due to increased advertising of these program and improved student quality since selective enrollment started. Thus, additional faculty resources were needed to assist with these special groups.

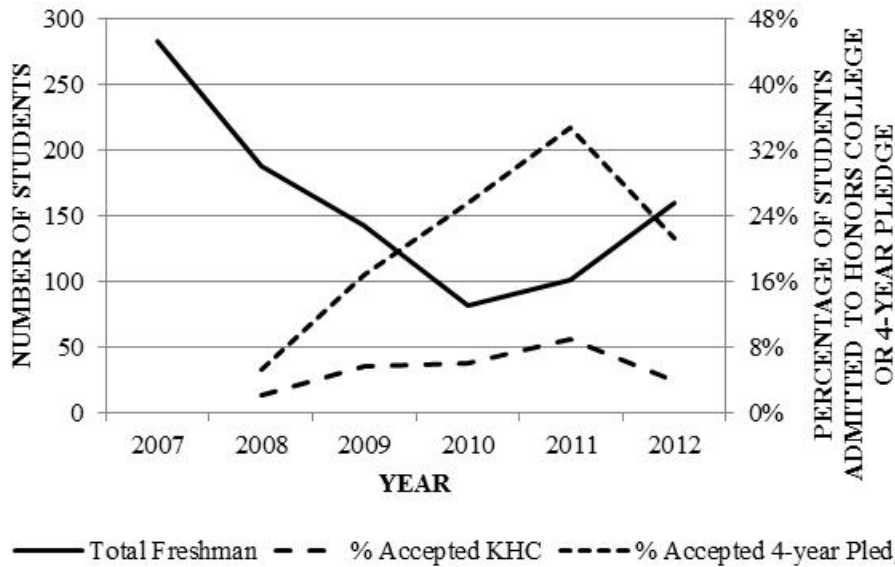

Figure 2 – Evaluation of the Students Accepted into the KHC and 4 year Pledge Programs

In order to address the advising challenges the committee developed the following objectives for the advising program.

1. Help students understand the nature and purpose of higher education.
2. Help students plan an educational program consistent with their interests and abilities.
3. Guide transfer students through the process of ensuring all their transfer units are properly reported within the university system.
4. Assist students understand the importance of extra-curricular programs: student clubs and teams, industrial experience and research experience.
5. Assist students in monitoring and evaluating their academic progress.
6. Advise students on the selection of courses appropriate for their interests and abilities (including course sequences and requisites).
7. Provide accurate guidance on university policies and procedures.
8. Refer students to special University services as needed.

It was unrealistic to expect each faculty member to be able to address all of these advising needs. Additionally, most faculty members were interested in only certain areas of advising. Thus a tiered advising structure was developed during the 2012 academic year. The advising committee evaluated the strengths of each faculty member and divided them into teams that became subject experts in advising a specific cohort of students. Three advising divisions were created: 1) Lower Division (underclassman); 2) 1st Year Transfer Students; and 3) Upper Division. In addition, all lower division advisors are responsible for advising the 4-year Pledge program and KHC students. Table 2 shows how each group addressed the advising objectives.

Table 2 - How to address advising objectives by each cohort?

Advising Cohort	Objective								No. of Faculty
	1	2	3	4	5	6	7	8	
Lower Division	■	■				■	■	■	5

1 st Year Transfers	■	■	■			■	■	■	2
Upper Division				■	■	■			11
4-year Pledge ^a	■	■		■	■	■	■	■	5
KHC ^a	■	■		■	■	■	■	■	5

a. Same Faculty as those in the lower division cohort.

Lower Division

Students in this division started Cal Poly Pomona as a freshman and have not completed Vector Statics. These students are assigned to their advisors for their first two years. In order for first year student to build a relationship with these advisors the faculty team teaching the Introduction to Civil Engineering (CE 122) course have worked together to develop a program that would require intrusive advising to student enrolled in the course. These students are required to develop a 4 to 5 year educational plan, which lays out the courses that they plan on taking during their time at Cal Poly Pomona. Student are expected to learn when classes are offered, evaluate prerequisites and set a goal to graduate. Finally, they need help navigating through Cal Poly Pomona.

1st Year Transfer

Students in this division entered transferred from a different school into Cal Poly Pomona. These students are assigned to a specified advisor for a single year. One of the challenges that transfer students face is determining which credits should have transferred and provided them with credit. In addition, this group also needs to develop a 3 year educational plan, which lays out the courses that they plan on taking during their time at Cal Poly Pomona. Student are expected to learn when classes are offered, evaluate prerequisites and set a goal to graduate. Finally, they need help navigating through Cal Poly Pomona.

Upper Division

Students are in this division if they started as a freshman at Cal Poly Pomona and this is their 3rd year or if they transferred into Cal Poly Pomona and this is their 2nd year. Most students in this program are starting to take courses in the 300 level CE curriculums. These advisors guide students on developing a career path and evaluate their academic progress.

4-Year Pledge

Student's part of this division will see a lower division advisor for the entire time they are part of the program. With the growing number of years it takes students to graduate, the university designed a program to guarantee graduation for entering freshmen. The pledge program involves a promise by students to balance school, work and personal responsibilities so that their commitment to education is honored. Students that participate in this program must remain in their selected major, must complete 25% (49.5 units) of the required graduating units per year, maintain a 2.2 cumulative GPA and earn a "C" or better in all courses. The advising program required by the 4-Year Pledge Program requires students to meet with their academic advisor each quarter to sign their quarter plan for priority registration. The program is based on the philosophy that if both the University and the student uphold their commitment, graduation

in four years should be guaranteed. Advisors assigned to work with 4-year pledge students cover both lower and upper division student advising.

Kellogg Honors College (KHC)

Student’s part of this division will see a lower division advisor for the entire time they are part of the program. The KHC is composed of a community of talented and motivated students. Many of these students are also part of the 4-year Pledge program. These students are invited to apply prior to entering Cal Poly Pomona. The KHC augments their scholastic experience at Cal Poly Pomona through individual advising within each department and KHC mentor to support personal and intellectual growth and successful program completion. Honors students take “Honors Sections” for several of their required classes, have access to an Honors Commons, and have funded opportunities. Requirements to maintain good standing in the Kellogg Honors College include: 3.30 or higher Cal Poly Pomona GPA, approximately 15 hours of Civic Engagement (community service) per year, and full time enrollment. Advisors assigned to work with KHC students cover both lower and upper division student advising.

Results

Starting in the 2009-2010 academic year, students were asked to fill out a survey about their experience as a student at Cal Poly Pomona’s civil engineering program at the end of the senior capstone course. In this survey students were asked to respond to the following statements:

- 1) The quality of advising I received related to academic planning was:
- 2) The quality of advising I received related to professional career planning was:
- 3) The quality of advising I received related to graduate school planning was:

Students responded based on the following scale:

- 1) Very poor;
- 2) Poor;
- 3) Satisfactory;
- 4) Good; and
- 5) Very Good.

The results of this survey, over the past 4 academic years, are summarized in Table 3. In the initial response to this survey, collected in the 2009-2010 academic year, a large majority of students stated that the level of advice they received was poor (2) to satisfactory (3). These results demonstrated the ineffectiveness of the department advising program in place at that time.

Table 3– Senior Exit Survey Reponses: Average responses from 1 (very poor) to 5 (very good)

Category	Academic Year			
	9-10	10-11	11-12	12-13
Number of Students	119	194	176	53
Curricular Planning	3.32	3.29	3.54	3.49
Career Planning	3.11	3.29	3.40	3.22

Grad School Planning	2.65	3.18	3.02	3.04
----------------------	------	------	------	------

Since the implementation of the comprehensive and proactive advising program described above, the survey results indicate a steady improvement the quality of advising students receive regarding curriculum, career and graduate school. The highest level of increase can be seen in how students responded to career and graduate school planning. The increases in career and graduate school planning are most likely linked to group advising sessions dealing specifically with these topics. Students rate the advising to be satisfactory (3) to good (4). The curricular advice does not show much of a change. This is understandable because intensive curricular planning advice started with freshmen and transfers in the 2010-2011 academic year. These students will not reach graduation until the 2014-2015 or 2015-2016 academic year. The department expects to see a change in the results starting in the 2014-2015 academic year.

Retention, or student persistence, within a major can be significantly affected by the quality of advising. As the department has changed its advising the overall persistence of students within the major is expected to improve due to department level advising. The data in Table 4 categorize students by whether they entered as freshman or transfers. It shows the percent that persisted within the civil engineering major each year based on the matriculation year (year started at Cal Poly Pomona).

Table 4 – Student Retention based on Years Spent at Cal Poly Pomona

Matriculation Term	Persistence Rate – Freshman						
	1	2	3	4	5	6	7
F 2005	85%	78%	69%	62%	44%	19%	5%
F 2006	83%	82%	77%	70%	45%	18%	
F 2007	88%	81%	78%	73%	52%		
F 2008	85%	80%	76%	65%			
F 2009	92%	84%	77%				
F 2010	99%	93%					
F 2011	97%						
Matriculation Term	Persistence Rate – Transfers						
	1	2	3	4	5	6	7
F 2005	88%	81%	38%	13%	9%	5%	3%
F 2006	89%	82%	42%	22%	11%	3%	
F 2007	77%	75%	52%	25%	13%		
F 2008	79%	73%	50%	19%			
F 2009	78%	74%	41%				
F 2010	94%	88%					
F 2011	92%						

The department switched from open to selective enrollment in 2009. The data suggests that this change has an effect on freshman persistence in both the first and second years starting in

2009. However, there are not enough data points to evaluate the persistence after the third year. Transfer persistence rates do not appear to increase significantly until 2010.

As shown in Table 4, before selective enrollment, the one year persistence rate was consistently less than 90%. Since selective enrollment started (2009) the one year persistence rate is well above 90% and the two year persistence rate is well over 80%. There is a significant drop in persistence in the third year for the 2009 cohort. The cause of this drop has not been determined. At the time of writing, data were not available to determine whether students leaving civil engineering switched to another STEM (science technology engineering math) program, switched to a non-STEM program or left the university. There is a large drop in the persistence of transfer students in the third year which is associated with graduation (33% of students graduated).

Students in the 2009 cohort did not benefit from the new advising program while those in the 2010 and 2011 cohorts did. As more data is collected it will be possible to compare the persistence of the 2009 cohort with later cohorts. This may provide some evidence on the effectiveness of the new advising program.

Future Work

Moving forward, more observation of the first (presented in an earlier paper) and second (presented here) stages of the advising program at Cal Poly Pomona are needed. As the second stage continues to be observed more data will help determine if there is a significant impact on student perception of advising, student retention rates, and thus overall graduation rates. More work needs to be done to separate out those students who switch majors after entering the program, drop out of school entirely or graduate from the persistence numbers.

Cal Poly Pomona, similar to many other universities has designed a system to provide students with their academic standing. A majority of the students fall under the “good academic standing” category. However, students who are having the most difficulty navigating the system will be addressed in the next stage of the CE departments advising program. These students fall into one of three categories: Early Warning (at Risk), Academic Probation, or Subject to Disqualification. An undergraduate student with a Cal Poly Pomona grade point average below 2.2 is considered at risk. An undergraduate student with an overall or Cal Poly Pomona grade point average that falls within the following ranges is placed on academic probation.

- Freshmen, 1.5 - 1.99 GPA
- Sophomores, 1.7 - 1.99 GPA
- Juniors, 1.9 - 1.99 GPA
- Seniors, 1.95 - 1.99

An undergraduate student is subject to disqualification if the student's grade point average is below the probation level listed above for more than two quarters. If a student falls into any of the three categories, a registration hold is placed upon their account and they are required to meet with their adviser to lift the hold. Meeting with their adviser, a student is required to develop a

plan to improve their GPA. Academic departments may disqualify a student if they fail to meet the terms of the advising worksheet or fail to make progress in the major.

Figure 3 provides a summary of the percent of students who fall into one of the three categories listed above. The data clearly show a significant reduction in students in academic trouble starting in fall 2010. This dramatic reduction is most likely due to a combination of selective enrollment and the new advising program within the CE department at Cal Poly Pomona. A great benefit of investing advising time with the underclassmen cohort is that it provides them with a solid base that can keep them out of academic trouble throughout their academic careers. This not only increases student success but also reduces the time needed to provide special advising for students in academic trouble.

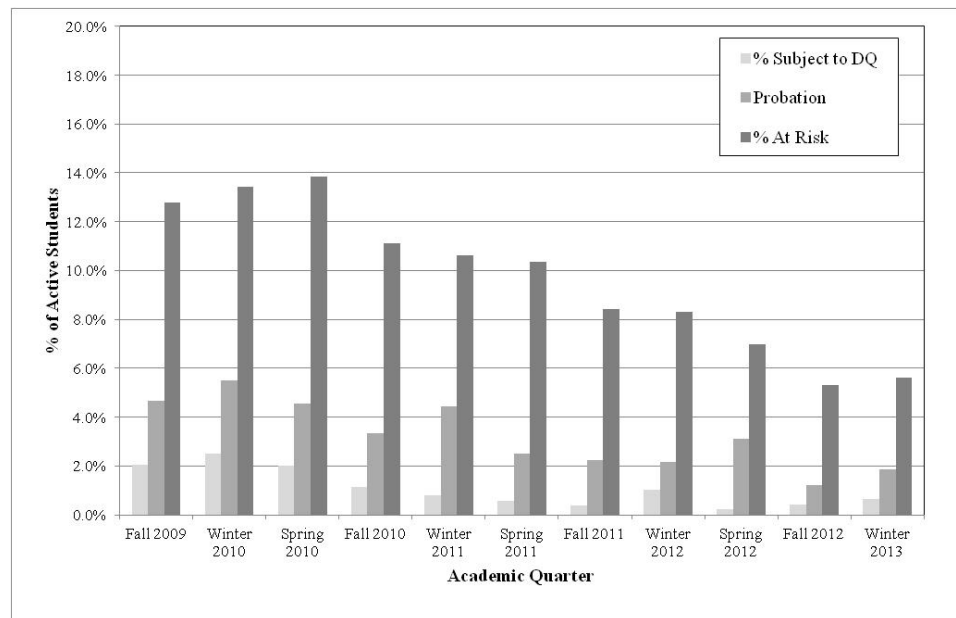

Figure 3 – Percent of Active Students: Subject to Disqualification, on Academic Probation or At Risk.

Summary

Overcoming organizational and structural constraints associated with advising in a large regional university was accomplished. The CE department at Cal Poly Pomona achieved their plan through the development of dedicated faculty to address student needs at various levels of the undergraduate education (i.e. lower division, upper division, transfers, KHC and 4-Year Pledge). Though the amount of data collected through the senior exit surveys are limited when it comes to evaluating the success of the program, students seem to be reacting favorably to the approach. The results also indicate that student persistence has improved but more research and data is needed to determine if this improvement is associated with selective admissions or advising. Persistence (i.e. retention) is not necessarily the primary objective, but it is the best indicator that an institution is meeting its goal of student satisfaction and success. Overall, students state that they are grateful that faculty cares about their overall success, which is similar to other studies that show students need more than just curricular advice⁷. The purpose of specialized advising teams is used to enhance the existing strengths of faculty members and improve the students experience at Cal Poly Pomona.

Acknowledgements

The authors would like to take this time to acknowledge the Civil Engineering department and College of Engineering at Cal Poly Pomona. They provided the faculty with support to make group advising feasible. The authors would also like to thank Ms. Angela Hicks, who is part of the department advising committee.

References

- [1] Settle, A. and J. Glatz. (2011). "Rethinking advising: developing a proactive culture to improve retention." SIGITE 2011 Proceedings of the 2011 Conference on Information Technology Education, West Point, NY: 9-14.
- [2] ASES_EWC (2010). "Engineering & Technology Enrollments, Fall 2010 — Engineering Workforce Commission." Retrieved January 23, 2012, 2012, from <http://www.ewc-online.org/>.
- [3] Crookston, B. B. (1972). "A developmental view of academic advising as teaching." Journal of College Student Personnel **13**: 12-17.
- [4] Pardee, C. F. (1994). "We profess developmental advising, but do we practice it?" NACADA Journal **14**: 59-61.
- [5] Schneider, A. (1998). "Harvard faces the aftermath of a graduate student's suicide." The Chronicle of Higher Education **45**(9): A12-A14.
- [6] Waterfall, E., E. Albrecht, et al. (2008). Developmental Advising – Exploring the Boundaries What are appropriate, caring limits? 2008 Annual Conference & Exposition, Pittsburgh, PA.
- [7] Metzner, B. S. (1989). "Perceived Quality of Academic Advising: The Effect on Freshman Attrition." American Educational Research Journal **26**(3): 422-442.
- [8] Shah-Fairbank, S. C. and K. Lamb. (2012). Addressing Advising Dissatisfaction through Group Advising, 2012 PSW ASEE Conference Proceeding, San Luis Obispo, CA.

Biographical Information

SEEMA C. SHAH-FAIRBANK is an Assistant Professor and RBF Fellow of Civil Engineering at California State Polytechnic University Pomona. She obtained her BS in Environmental Engineering from California Polytechnic State University, San Luis Obispo in 2001. Prior to attending graduate school at Colorado State University (CSU) she spent 3 years working as a Design Engineer for RBF Consulting in Storm Water Management. Where, she worked on various flood control, hydrology and hydraulics projects. She is a Licensed Professional Engineer in the State of California. She completed her graduate studies in Civil Engineering at CSU with a MS in 2006 and Ph.D. in 2009, where she specialized in sediment transport and river mechanics. She teaches courses in introduction to civil engineering, hydrology, hydraulics and environmental engineering. Dr. Shah-Fairbank is the current faculty adviser for the American Societies of Civil Engineers and Society of Women Engineers.

WILLIAM KITCH is a Professor of Civil Engineering at California State Polytechnic University Pomona. He completed his BS and MS in Civil Engineering from the University of Illinois in Urban Champaign. He received his PhD from the University of Texas at Austin. Prior to becoming a faculty member, William spent 21 years working as a civil engineering officer in the US Air Force and 3 years in private consulting. He is a registered Professional Engineer; his field of competency is in geotechnical engineering.

KENNETH LAMB is an Assistant Professor and Parsons Fellow of Civil Engineering at California State Polytechnic University Pomona. He completed his BSCE and PhD from the University of Nevada Las Vegas, and his Masters degree from Norwich University. Kenneth spent 8 years working for a civil engineering consulting firm in Las Vegas prior to starting his PhD program. As a registered Professional Engineer, his field of competency is in water resource engineering, and he teaches courses related to hydraulics and hydrology at Cal Poly Pomona.

An Innovative Approach to Educating Engineers in Entrepreneurship

Nasser Alromaih, Mark Rajai & S. Jimmy Gandhi
California State University, Northridge

Abstract

Entrepreneurship is a key driver of our economy. This is because wealth and a large number of jobs are created by small startup businesses. As these small businesses continue to grow and prosper, they create even more jobs and thus contribute to the overall well-being of the local and national economy.

One of the key ingredients of entrepreneurship is innovation and engineers as a profession come up with new ideas and thus are a hot bed for innovation. Engineering Schools are starting to realize the importance of entrepreneurship to engineers, which is why entrepreneurship is increasingly being taught as a part of engineering programs. However, the method of conveying the entrepreneurship education has been writing a traditional business plan. In this paper, the coauthors will discuss an innovative approach to educating engineers in entrepreneurship. This would include implementing in the curriculum new online tools for creating a business plan which have the mobility and convenience that today's generation of engineers have grown to know and expect. This revision of the entrepreneurship curriculum would be particularly important for engineering managers to understand and would thus be a valued contribution for engineering management programs across the country.

Introduction:

Entrepreneurship is more than just the creation of business ventures. It calls for the identification, assessment, and optimization of business ideas and opportunities to offer goods/services and for economic gains. Innovation, substantial wealth creation, and high risks characterize entrepreneurial ventures. Entrepreneurship is significant to engineers in terms of equipping them with entrepreneurial knowledge and skills to start and run successful business ventures. Entrepreneurship enables engineers to be innovative in the creation of technology-based products/services. The modern world

continues to witness a growing inclusion of entrepreneurship in engineering education. This is evident in the opening up of opportunities for engineering students and practitioners to undergo entrepreneurship training. This has taken the form of entrepreneurship programs in tertiary-level institutions, centers for engineering or entrepreneurship training, workshops, and conferences. The private sector supports entrepreneurship training for engineers through funding entrepreneurship education programs. Educational institutions have integrated entrepreneurship courses in their engineering programs to cater for students in engineering. Such efforts are evident in institutions in the US, Denmark, Northern Ireland, and the UK. Some of the entrepreneurial courses offered to engineering students include entrepreneurship, marketing, product design and development. To examine the inclusion of entrepreneurship training in engineering education, a survey was performed at California State University. The sample consisted of 20 respondents. They were engineering management students at the masters' level. Through a survey questionnaire, the authors found that entrepreneurship training is relevant and available to undergraduate and graduate engineering students. The entrepreneurship course was beneficial to students, particularly due to the ease of starting a business in the internet age. However, some respondents cited the need to improve entrepreneurship training at their respective schools. Taking this as an initiative, the authors decided to undertake this research effort to come up with innovative ways of teaching entrepreneurship. In this paper, the authors have discussed innovative ways to teach entrepreneurship to engineering graduates. The authors have first discussed ways in which entrepreneurship is currently taught to engineering majors and then have provided innovative alternatives to making changes to the entrepreneurship curriculum.

What is Entrepreneurship?

Entrepreneurship is an activity that involves using innovations, business skills, financial and material resources to transform creative ideas into economic goods. According to Refaat,⁵ "Entrepreneurship is an activity that involves the discovery, evaluation, and exploitation of opportunities to introduce new goods and services, ways of organizing, markets, process, and raw materials through organizing efforts that previously had not existed." Within a business context, entrepreneurship refers to setting

up and running a business, but entrepreneurial firms differ from small businesses in various ways. The quantity of wealth creation in successful entrepreneurial firms is greater than in small businesses. Equally, entrepreneurial ventures generate substantial wealth over a shorter duration than small businesses do. In addition, unlike in a small business, entrepreneurship consists of substantial innovation in the product, service, or business processes involved.

Importance of Entrepreneurship to Engineers

Engineers should be capable of deriving economic return from the knowledge that they possess. Through entrepreneurial engineering, trainees acquire the fundamental competencies necessary for successful entrepreneurship. According to Refaat,⁵ “Future engineers have to be trained how to recognize and develop new technologies and to take the technologies to market and to practice industry proven commercialization processes within an academic environment”. Entrepreneurship knowledge equips engineers with knowledge and skills useful in starting and developing their own firms. They acquire skills in writing business plans, obtaining angel or venture capital, marketing products or services, and acquiring intellectual property. They also learn how to identify customer needs, generate business value, and recognize viable business opportunities in the engineering and related industries that they could explore.

Entrepreneurship calls for innovation in products, services, or processes involved in business operations. Indeed, innovation is among the key factors that enhance the success of entrepreneurial ventures⁴. For engineering businesses and practitioners to succeed in their industry, they need to create innovative engineering projects. In addition, through entrepreneurship, they learn how to create technology-based opportunities, and ways of identifying, obtaining, producing, and transferring technology to generate viable products/services⁴. At the same time, organizations would like their engineering/technical staff to comprehend the numerous issues involved in developing the business. This is because such employees interact with various business functions, and their understanding of company operations is valuable. In addition to technical skills, engineers need to be capable of communicating effectively, managing time, and selling

business ideas ². Thus, knowledge of entrepreneurship enables engineering firms and employees to devise innovative ways of conducting business to enhance their success.

The partnership between entrepreneurship and engineering is evident in the opening up of entrepreneurship courses to engineers. This has mainly taken the form of Entrepreneurial Engineering programs at tertiary-level institutions or centers that offer training on entrepreneurship skills to engineers ³. In 2001, the “American Society for Engineering Education” created an Entrepreneurial Division to recognize entrepreneurship as a legitimate course in engineering education. The “International Conference in Engineering Education” that took place in Berlin, in 2001, focused on giving entrepreneurship education to engineers as one of its key themes ². The conference bore fruit as is evident in initiative such as the “Science Enterprise Challenge” in the UK, which focuses on entrepreneurial skills development for students and professionals in science and engineering fields ². In addition, efforts to offer entrepreneurial training as part of engineering education are evident in formal institutional collaborations such as between the Massachusetts Institute of Technology and Cambridge University, and joint academic research such as the Nottingham Conference held by the University of Nottingham Institute for Enterprise and Innovation and the US National Academy of Sciences ⁴.

Entrepreneurship and Engineering - How Entrepreneurship is Increasingly Taught to Engineers:

The trend towards the introduction of entrepreneurship courses in engineering and science began in the 1990s ⁴. Many engineering colleges in the US have initiated enterprise programs to teach engineering students how to launch and manage a business. Other tertiary-level institutions not specializing in engineering continue to offer entrepreneurship training to engineers and engineering students. For instance, the Pennsylvania State University has an Engineering Entrepreneurship Program that specifically targets scientists and engineers interested in technological innovation ¹². The program intends to develop the leaders of future high-tech firms by providing them with essential knowledge and skills in the establishment and management of such business ventures. The Xerox Centre for Engineering Entrepreneurship and Innovation offers

engineers entrepreneurship training, irrespective of whether they intend to launch a business or are undertaking a marketing task in their organizations. In Colorado, the Deming Center for Entrepreneurship allows engineers to access entrepreneurship training and emerge with a certificate in engineering entrepreneurship or a masters' degree ⁴.

Engineers can also access entrepreneurship training through the ASME. Through its Center for Education, ASME offers professional development courses for engineers, in addition to, organizing workshops and conferences to address engineering issues. Moreover, the organization promotes entrepreneurship training. In this event, engineering trainees, including students, compete by displaying their talents in product development. The aim of the event is to reduce the gap between entrepreneurship/business and engineering.

The private sector has made an effort to facilitate entrepreneurial training for engineers and engineering students. For instance, early this year, Kern Family Foundation gave a grant of \$2.4 million for a three-year period to Baylor University, University of Detroit, University of Dayton, and Villanova University for the establishment of entrepreneurship training programs ¹. The grant would also enhance the efforts of the universities in creating entrepreneurship curricula.

Entrepreneurship in Engineering Education - How Entrepreneurship is Currently Taught in Engineering Education:

The education sector has made several efforts to expand entrepreneurship training to include students and practitioners in non-business fields. For instance, at Texas A & M University, the Engineering Technology and Industrial Distribution Department offers courses on entrepreneurship, marketing, product design and development. Equally, the Biomedical Engineering Department has an elective entrepreneurship course. In addition, for the last 15 years, the University of Nevada, Reno, has been teaching entrepreneurship to electrical engineering students through a special capstone class. At the same time, in 1998, the university expanded the program to incorporate senior students and MBA students from the institution's Department of Mechanical Engineering and Business College ³. Moreover, the University of New Mexico has an Entrepreneurial Engineering

Class whose aim is to provide engineering trainees, practicing engineers and scientists an opportunity to acquire entrepreneurial skills to begin and develop successful firms or add value to the companies in which they are working ⁴. Stanford University teaches entrepreneurship to engineering and science students.

In 2004, the Danish Government established the “International Danish Entrepreneurship Academy” to enhance entrepreneurship teaching at the tertiary level to business and non-business students ³. Additionally, in Northern Ireland, there has been increased demand for entrepreneurship courses from students in Engineering and Science faculties. Since 2000, the “Northern Ireland Centre for Entrepreneurship (NICENT)” has been offering entrepreneurship education to students in the engineering, science, and technology disciplines. The University of Cambridge (UK) also offers entrepreneurship education to science/technical students. Moreover, the key engineering schools in Norway offer entrepreneurship courses, having found that about 15% of engineering students take an interest in entrepreneurship ³. Similarly, the Nottingham University Business School offers entrepreneurship courses to engineering students taking MBA. The course syllabus includes modules such as entrepreneurship in the 21st century, creative thinking and problem solving, becoming a creative entrepreneur (team project), and entrepreneurship in action. Most of the students are in full-time employment in managerial positions ³. Similarly, the University of Nottingham teaches entrepreneurship to engineering students at undergraduate level. The University of Michigan has collaborated with schools of engineering, such as the Center for Entrepreneurship at the College of Engineering and the Ross School of Business to offer an entrepreneurship program at masters’ level. In addition, the University of Luxembourg integrated entrepreneurship in the curricula of the engineering degree at masters’ level. The College of Engineering at Marquette University is currently developing a course in Entrepreneurial Engineering ⁵.

Entrepreneurial engineering programs at undergraduate level combine students’ basic technical courses with essential entrepreneurship subjects such as accounting, finance, leadership, teaming, intellectual property protection, and cultural diversity. This exposes the undergraduate student to entrepreneurship during the formative phase of their engineering education. At graduate level, engineering programs incorporate

entrepreneurship subjects and projects with engineering management courses. Entrepreneurial courses at this level may include technology needs assessment and road mapping, planning and development of technology-based products, services, or processes. Thus, students get opportunities to apply their technology-based courses within an entrepreneurial context. At the same time, entrepreneurship education for engineers and engineering trainees accelerates the application of science and technology in the economy.

Survey

To establish how Entrepreneurship is currently a part of Engineering Education, we conducted a survey among engineering students at California State University-Northridge. We surveyed 20 respondents, all of whom were masters' level students. The following were the survey questions for the respondents to answer.

Survey Questions

1. At what level(s) does the institution offer an entrepreneurship course?
 - a) Undergraduate
 - b) Graduate
 - c) Undergraduate and graduate
2. Name some of the entrepreneurship courses
3. Do you find the entrepreneurship course beneficial?
 - Yes
 - 3a) If yes, explain how
 - No
 - 3b) If no, explain why not
4. Do you feel that the courses needs improvement?
 - Yes
 - 4a) If yes, explain how
 - No
 - 4b) If no, explain why not

Survey Results

The respondents mentioned that the entrepreneurship course is at graduate levels. The respondents mentioned that their institution offers an entrepreneurship courses at masters' level. The students mentioned that the entrepreneurship course units include entrepreneurship are Innovation (MSE 602), Professional Management (MSE 608b), and other financial and economical courses.

All respondents (100%) found the entrepreneurial courses beneficial. The reasons cited included gaining entrepreneurial knowledge and skills, becoming an innovative engineer, enhancing one's capability to begin a business in the engineering field and creating jobs for others. In the section below, the authors have presented the survey results that were collected from the 20 respondents at Cal State, Northridge.

In Figure 1, the authors have presented the results for Q3, "Do you find the entrepreneurship courses beneficial?"

Figure 1: Results showing if the students found entrepreneurship courses beneficial.

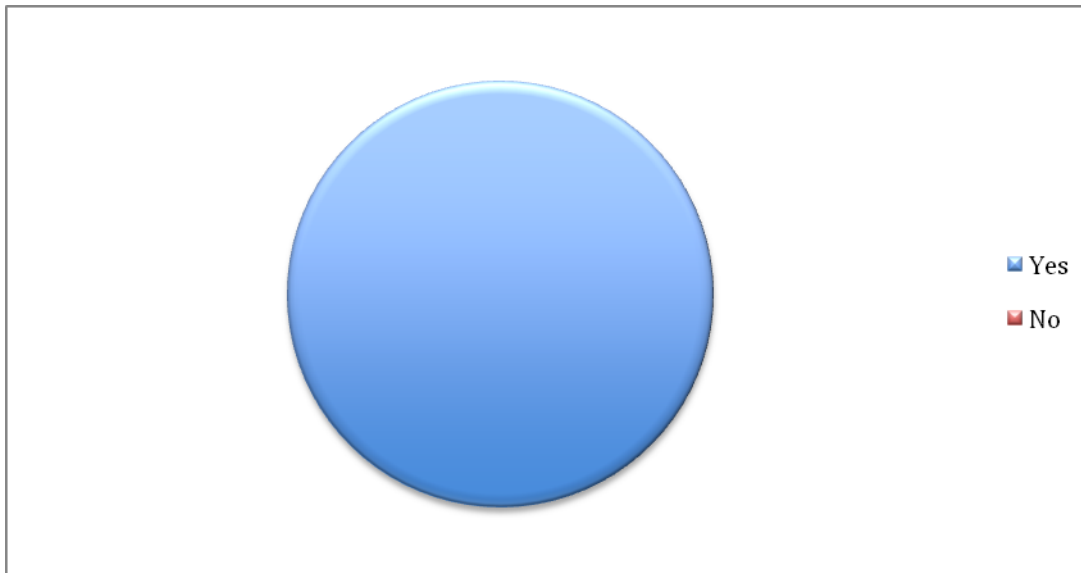
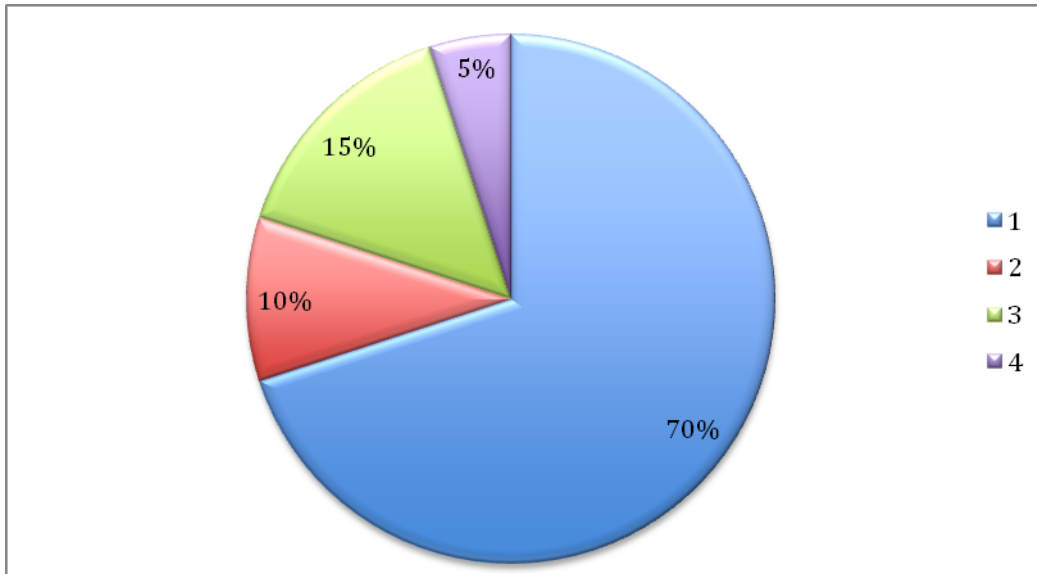

Figure 2: Reasons why entrepreneurship courses are considered beneficial by students



In Figure 2, the authors have portrayed the various reasons why the students surveyed found the entrepreneurship courses to be beneficial. Option 1, which entailed gaining entrepreneurial knowledge and skills was the reason that majority of the students stated the course was beneficial to them. This resonated with the fact that engineers working for companies may be given expanding responsibilities that expose them to innovative and entrepreneurial activities, with the associated knowledge and skills, which the students do not want to miss out on.⁶

- 1) Gaining entrepreneurial knowledge and skills (70%); 2) becoming an innovative engineer (10%); 3) enhancing one's capability to begin a business in the engineering field (15%), and 4) creating jobs for others (5%).

Eight of the respondents from the California State University, felt that the entrepreneurial courses of the institution needed improvement. The students wanted practical opportunities to practice entrepreneurial theory, regular visits to entrepreneurial engineering firms, organization of workshops or seminars on entrepreneurship and engineering that they could attend. The authors realized that this was a valid expectation from the students as research has shown that practical experience in the field of entrepreneurship is invaluable for the students.^{7, 8} Moreover, they wished that the entrepreneurship lecturers give additional attention to theory, prior to introducing the practical part of the course. They also wanted the institution to invite entrepreneurship experts regularly to instruct them on entrepreneurship in engineering education. In

addition, they wanted the institution to organize visits to engineering firms that have embraced entrepreneurial practices to give them more opportunities to understand the link between entrepreneurship and engineering ⁹.

In Figure 3, the authors have portrayed the findings of the survey showing that 30% of the students surveyed felt that the entrepreneurship courses needed improvement.

Figure 3: Results of whether the students felt that the courses need improvement?

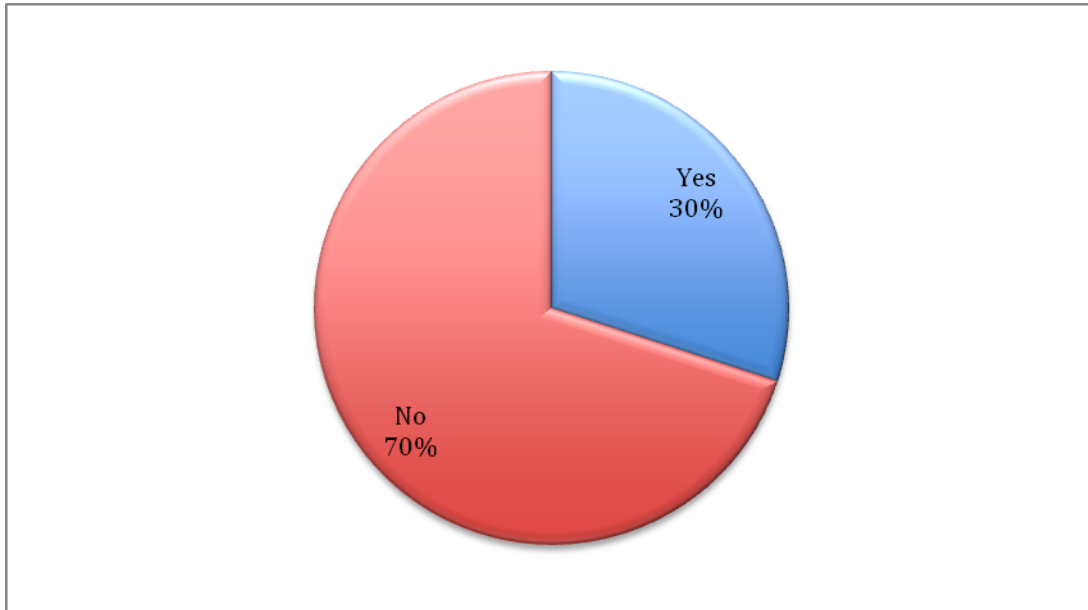

The suggestions that the students made for improvement are listed in Table 1. These suggestions were taken into consideration, when the authors revamped the way the entrepreneurship course would be taught at CSUN. This ties in with CSUN's and the MSEM's policy of implementing continuous process improvement (CPI) in their courses every semester.

Table 1: Suggestions for improvement of entrepreneurship courses as made by students:

Suggestions for improvement
<ul style="list-style-type: none"> ➤ Practical opportunities to practice entrepreneurial theory; ➤ Regular visits to entrepreneurial engineering firms; ➤ Organization of workshops or seminars on entrepreneurship and engineering that they could attend ➤ Entrepreneurship lecturers give additional attention to theory, prior to introducing the practical part of the course; ➤ Invite entrepreneurship experts regularly to instruct them on entrepreneurship in engineering education; ➤ The institution to organize visits to engineering firms that have embraced entrepreneurial practices

Specific changes that will be implemented in Entrepreneurship teaching at CSUN

Based on feedback that the authors received from the survey respondents and as part of the continuous process improvement culture in the MSEM department at CSUN, the authors have recommended the following changes to be implemented to teaching entrepreneurship:

- (i) The use of new software will be incorporated in the entrepreneurship course. This software is called “LivePlan” and is created by Palo Alto Software based in Oregon. The benefits of using this software are as follows: ¹⁰
 - a. The software has been created by entrepreneurs themselves, who have gone through the entrepreneurship process and hence know what the requirements are for an effective business plan. This also helps the students get an exposure to the way an entrepreneur puts a business plan together.

- b. The students can share the software online with other team members and all the updates are seen live. Hence, the chance for confusion occurring because of various versions of the business plan going back and forth is practically eliminated. ¹¹
 - c. Based on the research the student does and provides input to the software, the software then provides financial outputs as well as provides documents in a presentable format – thus saving the student valuable time. Instead of editing the final presentation, due to the easy export feature to MS Word and MS Powerpoint, the students can spend that extra time on doing additional research to come up with a more accurate target market.
- (ii) There will be more case studies related to Entrepreneurship included in the course. This will increase the student’s analytical thinking and make it possible to apply the concepts they learn in the classroom more efficiently.
 - (iii) The instructors who teach the entrepreneurship courses at CSUN will be making prior arrangements with entrepreneurs to come to class and share their experiences with the students. This makes the students feel that it is truly possible to be an entrepreneur and enhances the “can-do” attitude of the students.
 - (iv) The students will be asked to pick a project and work on it throughout the semester in teams so that they also learn that entrepreneurship is generally done by a team and that team dynamics will exist and they have to learn how to manage them as best as possible.

Conclusion

Entrepreneurship education has increased exponentially in the last 2 decades, with about two dozen schools offering entrepreneurship courses about 20 years ago and about 1600 schools offering it now. This clearly shows the importance entrepreneurship has to the US economy and it is imperative that we as educators teach it in such a way as to really enhance students’ interest in the subject and not just make it another course that

they take in order to graduate. Furthermore, entrepreneurship courses should be taught in conjunction with actual entrepreneurs as the experience they bring to the classroom is considered invaluable to the students as it is something they cannot get from any textbook. The modifications made to the existing entrepreneurship curriculum are expected to benefit the students' understanding and ability to participate on entrepreneurship projects.

Bibliography

1. Baylor University. (2012). Baylor Receives Grant to Foster Entrepreneurial-Minded Engineers. Retrieved October 18, 2012 from <http://www.ecs.baylor.edu/news.php?action=story&story=112785>
2. Drucker, P. (2007). *Innovation and Entrepreneurship: Practice and Principles*. Oxford, UK:
3. Butterworth-Heinemann, European Commission. (2008). Entrepreneurship in higher education, especially within non-business studies. Retrieved October 18, 2012 , http://ec.europa.eu/enterprise/policies/sme/files/support_measures/training_education/entr_highed_en.pdf
4. Goldberg, D. (2006). *The Entrepreneurial Engineer*. Hoboken, NJ: Wiley
5. Refaat, A. (2009). The Necessity of Engineering Entrepreneurship Education for Developing Economies. *International journal of education and information technologies*, 3(2), 85-96
6. Polczynski, Mark & Stanley Jaskolski (2005), *Entrepreneurial Engineering Education*, NCIIA 9th Annual Meeting, March 17-19, 2005, San Diego, CA.
7. Frans TSiBA Admin (2012), *Practical Experience through Entrepreneurial Implementation*, Retrieved on January 12, 2013,

- <http://www.tsiba.org.za/index.php/blog/view/practical-experience-through-entrepreneurial-implementation/>, Dated October 30, 2012.
8. J. Kroon, S. de Klerk and A. Dippenaar (2003), *Developing the next generation of potential entrepreneurs: co-operation between schools and businesses?*, South African Journal of Education, Volume 23, Issue 4, Pg 319-322.
 9. Government of Quebec (2012), *Entrepreneurs in the Classroom*, http://inforoutefpt.org/entrepreneuriat/documents/cegep_ang.pdf
 10. Palo Alto Software (2012), *Live Plan Software for Business Plans*, <http://www.liveplan.com/reviews>, Retrieved on January 13, 2013.
 11. Nielsen, Kate (2013), *Top Ten Advantages of Using Online Storage Services*, <http://online-storage-service-review.toptenreviews.com/top-ten-advantages-of-using-online-storage-services.html>, Retrieved on January 12, 2013
 12. Pennsylvania State University (2012), SMEAL College of Business, <http://www.smeal.psu.edu/fcfe/>, Retrieved on January 10, 2013.

Classical Test Theory Analysis of the Dynamics Concept Inventory

**Natalie Jorion, Brian Self, Katie James,
Lianne Schroeder, Lou DiBello, Jim Pellegrino**

**University of Illinois, Chicago/ California Polytechnic State University/
University of Illinois, Chicago/ University of Illinois, Chicago/ University of Illinois,
Chicago**

Abstract

The Dynamics Concept Inventory (DCI) is an instrument designed to measure students' conceptual understanding of dynamics. Its primary intended use is to examine the effectiveness of teaching practices for helping students overcome misconceptions in the domain, based on evidence of student understanding. Given that many instructors are administering this assessment in their classrooms, it is important to determine how well the instrument functions relative to the claims of its developers and relative to its intended uses. A further interest is to provide guidance for improving the instrument by identifying aspects of the instrument that may be modified or enhanced. Multiple analyses were conducted for data from two administrations of the instrument using classical test theory. These analyses provide insight into the DCI's conceptual content, measurement properties, and relative validity given its intended use. Overall, evidence shows that the instrument is well suited for low stakes formative assessment use but may have limitations for high stakes uses in its current form. Guidance is provided for the effective implementation and interpretation of the instrument for this purpose. Recommendations are also suggested for future iterations of the instrument and to provide evidence for the resultant changes in measurement properties.

Background

In undergraduate engineering courses, professors often stress procedural problem solving over conceptual understanding of the domain (Miller et al., 2005; Minstrell, Ruth Anderson, & Li, 2011). As a result, engineering students are able to complete courses with high marks while failing to achieve understanding of key concepts and simultaneously maintaining problematic misconceptions in the domain. Some of these misconceptions can be attributed to faulty preconceptions and inflexible knowledge transfer stemming from instructional examples (Ruiz-Primo et. al, 2012). Concept Inventories (CIs) have been cited as a means to address this instructional dilemma. CIs are low-stakes, multiple-choice assessments that purport to measure students' conceptual understanding in a discipline. The multiple-choice distractors are based on common student mistakes, which are often derived by developers from student responses to open-ended questions. Many instructors are using these instruments to make inferences regarding students' understanding of the domain, with the goal of improving future teaching.

One such CI is the Dynamics Concept Inventory (DCI), which claims to assess concepts that instructors perceive as difficult for students (Gray et. al, 2005). This test has promise as a tool to help improve instruction by providing evidence of student thinking. An important step in supporting instructional decisions with student data is validating the test's measurement properties. In this paper, Classical Test Theory (CTT) is used to investigate functioning of the questions of the inventory and of the inventory as a whole. These analyses can help instructors interpret students' scores on the DCI. In addition, we substantiate various aspects of the validity of the DCI for particular kinds of classroom use and provide some ideas of how the inventory may be modified or improved.

Several analyses have been conducted on previous versions of the DCI for the purpose of selecting items for the current instrument. These analyses include basic reliability tests (Cronbach's alpha) and distractor analyses (Gray et al., 2005). The current study differs from earlier research in several regards. First, it analyzes performance on the most current version of the DCI. Second, it examines how the instrument functions overall and explains how these findings affect interpretation and use of inventory outcomes. In addition to reliability analyses, a measure of standard error is presented with an explanation of how that informs interpretation of total scores. Third, the study examines how the items are functioning in the context of the instrument as a whole, which can help users understand the utility of the items for informing and refining instruction.

Method

Participants

The analyses made use of post-test DCI data from students at two large public universities. One of these schools is on the semester system, while the other is on the quarter system. The students took the test for an undergraduate dynamics course during June, 2011. The majority of these students were sophomore engineering majors, including mechanical, civil, aero, biomedical, and industrial engineering. The combined datasets totaled 966 cases.

Instrument

The version 1.0 of the DCI that was analyzed has 29 questions, five of which are taken without change from the Force Concept Inventory (FCI). The developers provided a list of 14 conceptual categories for the inventory questions, ranging from one to five items per category (see Appendix for a list of the concepts and assignment of items).

Procedures

We used CTT to investigate the extent to which the overall test total score is reliable and whether there are particular items that seem to function differently than the rest of the test. CTT assumes that for a given assessment each examinee possesses a "true score" and that each observed score is measured as the true score plus error:

$$X = T + \varepsilon$$

where X represents the observed score, T represents the true score, and ϵ represents the error. The true score can be understood conceptually as the examinee's average observed scores on the same assessment over an infinite number of times (assuming no test-retest effects).

Since the true score cannot be observed directly, various approaches have been developed to estimate the reliability of the observed total score as a relationship between the observed score and the true score. Cronbach's alpha, in particular, measures internal consistency of the individual item scores that make up the total score. Alpha can range from 0 to 1; an alpha close to 1 indicates that the items are closely related as a group, suggesting a dominant underlying construct. The formula for Cronbach's alpha is defined as follows:

$$\alpha = \frac{N\bar{c}}{(\bar{v} + (N - 1)\bar{c})}$$

where N is the number of items, \bar{c} is the average inter-item covariances among all item pairs, and \bar{v} is the average of the item variances. The formula for alpha is sensitive to the number of items in the assessment instrument. Typically the greater the number of items on a test, the greater the value for alpha. Values of alpha greater than 0.7 are acceptable, and measures between 0.8 and 0.9 are desirable (Nunnally & Bernstein, 1994).

The standard error of estimation enables us to define a confidence interval for a student's true score given her observed scores. The measure uses the standard deviation of the test scores and the overall test reliability:

$$SEE = (S_X)(\sqrt{r_X})(\sqrt{1 - r_X})$$

where r_X is the reliability coefficient and S_X is the standard deviation of test scores (Harvill, 1991). The greater the test reliability, the smaller the standard error of measurement is. A test with perfect reliability—that is, a Cronbach's alpha of 1—would have a standard error of estimation of 0 and a true score equal to the observed score. Using this formula, we can derive the approximate 68% confidence interval for a student's true score around an observed total score. For example suppose an examinee's observed score is X . Then the 68% confidence interval for that student's true score is:

$$CI = (\bar{X} + (r_X)(X - \bar{X})) \pm SEE$$

where \bar{X} is the mean score for a reference group and X is the obtained test score, and SEE is the standard error of estimate as given above. This formula indicates the confidence intervals for the unobserved true score around the observed score X . In other words, for a given Cronbach's alpha and related standard error of estimate as computed above, this formula provides a confidence interval for the student's true score, given their observed score. A specific example of application of this statistic is presented below in the Results.

Functioning of individual items was evaluated using three measures. First, a quantity called "*Cronbach's alpha if-item-deleted*" was used which is calculated exactly the same way as the Cronbach alpha for total score, except it is calculated on the set of all items except for the item being deleted. This measure is compared with the alpha of the overall test. Since this is a Cronbach's alpha, it ranges from 0.0 to 1.0. As previously mentioned, the number of items on a

test directly affects Cronbach's alpha; the more items on a test, the greater the value of alpha should be, assuming uniform quality of the items. Deleting an item from an assessment should, in theory, result in a lower alpha. Thus, items that have a *higher* alpha if-item-deleted score than the overall alpha they are likely detracting from the assessment's overall reliability. This may be because an item is measuring a different construct from the rest of the test or simply because the item is a poor measure of the ability measured by the remainder of the items in the test.

The second statistic investigated was *item difficulty*. A given question's difficulty (or p-value) is the proportion of examinees that answered the question correctly. The item difficulty value also ranges from 0.0 to 1.0. The greater the value, the easier the item is. Ideally, this statistic should be between 0.2 and 0.8 for an item to be sufficiently informative. There are several possible explanations for items that have a measure of less than 0.2: the item may be too difficult relative to the sample tested, the item may not be worded clearly, or there may be more than one correct answer. We further investigated particular items that fell out of this range. We also created distributions of answer choices selected for each item, noting any instances where there a distractor was chosen more frequently than a correct item choice.

The third measure used was *item discrimination*, which is calculated as the point-biserial correlation between item score and total score. This is just the ordinary Pearson correlation between a 0/1 item score and the total score excluding the item of interest. This statistic indicates the extent to which an item discriminates between students with higher and lower total scores. In other words, an item with a greater discrimination is more frequently answered correctly by students with a "high" level of knowledge than by those with a "low" level of knowledge. This statistic can range from -1.0 to 1.0, with negative values indicating items that were more frequently answered correctly by students with a lower ability. An item's discrimination should be greater than 0.2. Items with a value lower than 0.2 may be testing a different construct than the rest of the test, may have a seductive distractor selected more frequently by those students with a higher ability, or may be a poor item for other reasons.

Results

The mean of the total scores on the DCI for all students from the given sample was 14.27 ($SD=4.59$) with a maximum possible score of 29. Figure 1 shows the distribution of student scores. The overall Cronbach's alpha for this test is 0.744, which is a modest reliability measure for a test with 29 items intended to be used for formative assessment or for instructional evaluation purposes. Given the standard deviation and the reliability, the standard error of estimation for the sample is 2.00. We can use the formula given above to illustrate the effect of standard error of estimation for interpreting student total scores. For example, suppose a given student has total score close to the mean score, for example total score 14.

Applying the formula given above, the 68% confidence interval is defined to be:

$$\begin{aligned} & \left(\bar{X} + (r_X)(X - \bar{X}) \right) \pm SEE = \\ & (14.52 + (0.744)(14 - 14.52)) \pm 2.00 = \\ & \text{the interval from 12.07 to 16.07.} \end{aligned}$$

Thus there is a 68% chance that the student's true score is between 12 and 16 (Harvill, 1991). Confidence bands that do not overlap have a high probability of being distinct from each other. By contrast, two students with scores 12 and 16 cannot be inferred with 68% confidence to have different true scores. With the same mean and standard deviation of total scores, for the standard error of estimation to decrease to 1, the reliability measure would have to increase to 0.95. However, it should be noted that the effective standard error of estimate for the observed score increases the further the observed score is from the mean. More sophisticated measures exist for calculating the standard error of estimation which use item response theory and other model-based approaches (Baker, 2001; Crocker & Algina, 2006; Hambleton et al., 1991).

Individual item analyses are presented in Table 1. Bolded items denote measures that are outside of the recommended range for each statistic. The majority of the items had adequate item discrimination measures over 0.2. Items with difficulty measures of less than 0.2 (i.e., that were difficult for this sample of examinees) are Q3, Q5, and Q29. Items that had difficulty measures of more than 0.8 (i.e., that were somewhat easy for this group) are Q1, Q7, and Q14. Several questions have higher alphas if-item-deleted scores: Q5, Q10, Q13, and Q23, suggesting that they are internally inconsistent with the other items of test and might not cohere well conceptually with the rest of the test. The item discriminations and difficulties are fairly well distributed, indicating that the questions are suitable to assess a wide range of conceptual mastery of the domain (see Figure 2).

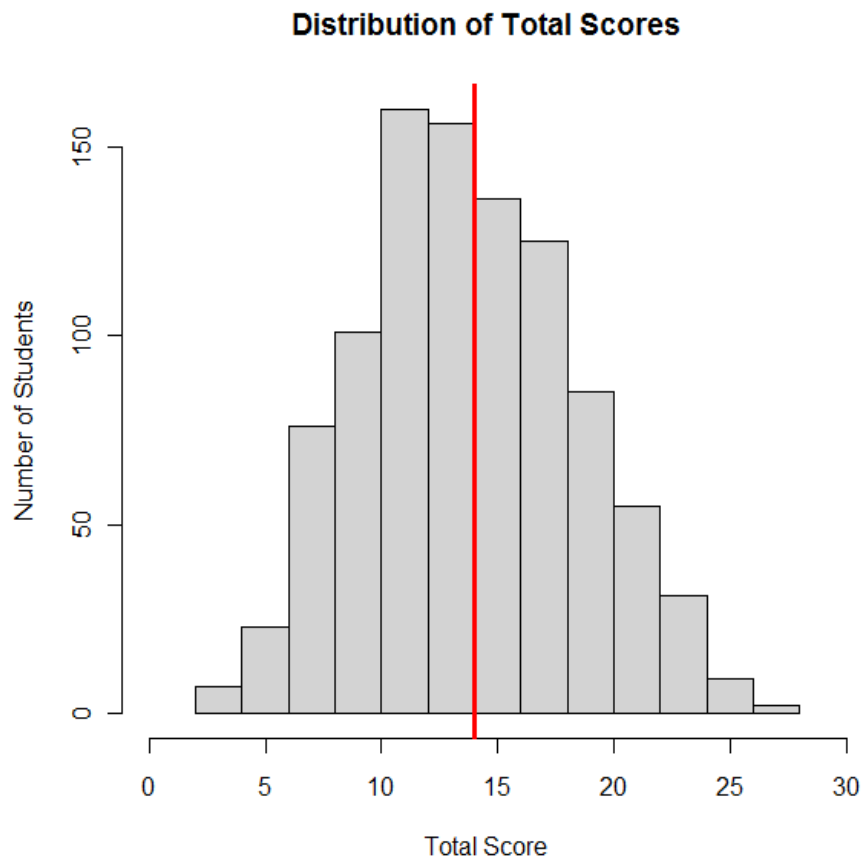

Figure 1. Total Score distribution (n=966). Red line indicates median score.

Table 1. Item statistics for the DCI.

Measures in bold indicate either a discrimination measure below 0.2, a difficulty measure outside the range of 0.2-0.8, or a Cronbach's alpha-if-item-deleted of more than the overall test reliability (0.744).

Item	Discrimination	Difficulty	Cronbach's Alpha If Item Deleted
Q1	0.196	0.891	0.740
Q2	0.145	0.639	0.744
Q3	0.255	0.133	0.738
Q4	0.403	0.609	0.728
Q5	-0.004	0.058	0.747
Q6	0.338	0.525	0.732
Q7	0.262	0.839	0.737
Q8	0.370	0.637	0.730
Q9	0.341	0.371	0.732
Q10	0.080	0.443	0.749
Q11	0.192	0.332	0.741
Q12	0.223	0.421	0.739
Q13	0.104	0.355	0.747
Q14	0.248	0.913	0.738
Q15	0.326	0.642	0.733
Q16	0.385	0.729	0.729
Q17	0.403	0.715	0.728
Q18	0.248	0.429	0.738
Q19	0.183	0.273	0.741
Q20	0.215	0.684	0.740
Q21	0.363	0.322	0.730
Q22	0.395	0.588	0.728
Q23	0.114	0.360	0.746
Q24	0.360	0.536	0.730
Q25	0.286	0.520	0.735
Q26	0.200	0.294	0.740
Q27	0.358	0.431	0.731
Q28	0.222	0.402	0.739
Q29	0.262	0.177	0.737

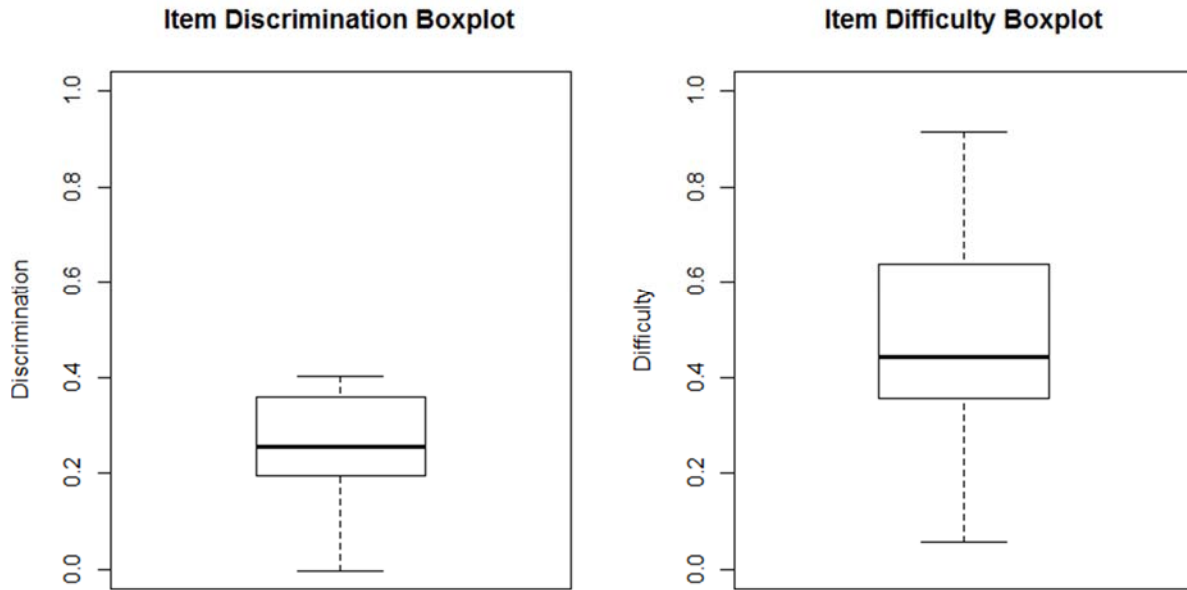

Figure 2. Range of item discriminations and difficulties. Note that discrimination values can be negative, with minimum possible value of -1; 0 is the minimum here for comparative purposes.

Discussion

The analyses indicate that as a whole, the DCI is a fairly reliable instrument with a reasonable standard error of estimation in the score distribution close to the mean. Even though the test purposefully covers a wide range of concepts within the domain of dynamics, the reliability measure suggests a relatively cohesive assessment. The standard error indicates the degree of confidence instructors can have in students' observed scores and differences between bands of observed scores.

It should be noted that not all the items are contributing equally to its alpha measure. Those items with values outside the desired range of difficulty and those with low inter-item covariance do not add as much to the overall reliability. However, this by itself does not negate the value of items that fall outside this range. Easy items could be retained if it is felt that they can indicate whether students have mastered the most fundamental concepts. That argument may be made in particular for the items drawn from the FCI (Q1, Q7, Q14, Q15, and Q16). Items with difficulties of less than 0.2 may be included in an inventory for their value in indicating understanding of more challenging concepts. In this way, both the interpretation of the DCI in its existing form as well as the decision of which items are candidates for enhancement or replacement can be informed by the variety of analyses reported here as well as possible instructional considerations give the individual item data.

The results suggest how engineering instructors could appropriately leverage results from the DCI to inform instruction. The DCI would be well-suited for assessment at the student-level and the classroom-level. On an individual-level, the test could indicate which students still harbor misconceptions about dynamics. Instructors could then create interventions as appropriate. On a classroom-level, the DCI could indicate whether instruction of particular concepts has been

effective. If instructors find that certain misconceptions are prevalent among the majority of their students on a post-test, they may want to investigate the corresponding lessons. In some cases, instruction may help to dispel a problematic preconception, but then incite another misconception.

Although classical test theory can provide informative measures of test functioning, it does have limitations. For example, CTT measures are less accurate for student scores at the extreme ends of the total distribution. To further understand the performance of the inventory and the interpretation of test and item performance we are currently using different measurement models such as Item Response Theory (IRT). We are also using IRT, factor analysis, and structural equation modeling to uncover the DCI's underlying structure. Such analyses can be helpful for determining whether the sub-scores of the inventory have meaningful interpretations.

Conclusion

In this study, Classical Test Theory was used to investigate the measurement properties of the most current version of the DCI. To analyze the functioning of the DCI as whole, the focus was on reliability measures and the standard error of estimation. These measures can indicate the degree of confidence one can have regarding the relationship between students' observed scores and their true scores. Individual item analyses were used to show how they were functioning within the larger assessment. The wide range of item difficulty can help instructors differentiate between varying degrees of dynamics conceptual mastery. Overall, the results indicate that the DCI can be a valuable low-stakes instrument that professors can use to identify conceptual mastery of dynamics. In addition, the specific results suggest areas in which improved functioning of the instrument may be possible by enhancing or replacing some items.

Acknowledgements

This material is based upon work partially supported by the National Science Foundation under Grant Nos. 0918552, 0920589, 0815065. Any opinions, findings, and conclusions or recommendations expressed in this material are those of the author(s) and do not necessarily reflect the views of the National Science Foundation.

References

- Baker, F. (2001). *The basics of item response theory*. ERIC Clearinghouse on Assessment and Evaluation, University of Maryland, College Park, MD. Retrieved October 30, 2004, from <<http://echo.edres.org:8080/irt/baker/http://edres.org/irt/baker/>>
- Crocker, L. & Algina, J. (2006). *Introduction to classical and modern test theory*. New York: Wadsworth Publishing Co.
- Hambleton, R. K., Swaminathan, H., & Rogers, H. J. (1991). *Fundamentals of item response theory (Measurement Methods for the Social Science)*. Newbury Park, CA: Sage Publications.
- Gray, G., Evans, D., Cornwell, P., Costanzo, F., & Self, B. (2005). *The Dynamics Concept Inventory Assessment Test: A Progress Report*, Proceedings of the 2005 American Society for Engineering Education Annual Conference, Portland, OR.
- Harvill, L. M. (1991). Standard error of measurement. *Educational Measurement: Issues and Practice*, 10(2), 33-41.
- Miller, R. L., Streveler, R., Olds, B., & Nelson, M. (2005). Concept Inventories Meet Cognitive Psychology: Using Beta Testing as a Mechanism for Identifying Engineering Student Misconceptions. Proceedings of the American Society for Engineering Education Annual Conference (electronic), Portland, Oregon.
- Minstrell, J., Anderson, R., & Li, M. (2011, May). Building on Learner Thinking: A Framework for Assessment in Instruction. workshop of the committee on Highly Successful Schools or Programs for K-12 STEM Education. National Research Council, Washington, DC, May.
- Nunnally, J. C. & Bernstein, L. (1994). *Psychometric Theory* (3rd ed.) McGraw-Hill, New York.
- Ruiz-Primo, M. A., Li, M., Wills, K., Giamellaro, M., Lan, M. C., Mason, H., & Sands, D. (2012). Developing and evaluating instructionally sensitive assessments in science. *Journal of Research in Science Teaching*, 49(6), 691-712.

Appendix: Grouping of DCI Concepts

Concepts (from 2005 ASEE paper)

Concept	Question
1. Different points on a rigid body have different velocities and accelerations, which vary continuously.	2,3
2. If the net external force on a body is not zero, then the mass center must have an acceleration and it must be in the same direction as the force.	7,11,15,16, 24
3. Angular velocities and angular accelerations are properties of the body as a whole and can vary with time.	4, 6
4. Rigid bodies have both translational and rotational kinetic energy.	10
5. The angular momentum of a rigid body involves translational and rotational components and requires using some point as a reference.	25, 26
6. Points on an object that is rolling without slip have velocities and acceleration that depend on the rolling without slip condition.	21, 22, 23
7. In general, the total mechanical energy is not conserved during an impact.	18, 20
8. An object can have (a) nonzero acceleration and zero velocity or (b) nonzero velocity and no acceleration.	9, 23
9. The inertia of a body affects its acceleration.	12,13,17
10. The direction of the friction force on a rolling rigid body is not related in a fixed way to the direction of rolling.	27,28
11. A particle has acceleration when it is moving with a relative velocity on a rotating object.	5, 19
12. An object moving in a curved path always has a normal component of acceleration	8
13. The direction of the friction force between two objects depends on their relative velocity or their tendency for relative motion.	29
14. Newton's third law dictates that the interaction forces between two objects must be equal and opposite.	1,14

***CoursePedia* for Engineering Courses**

Kiran George

Computer Engineering Program
California State University, Fullerton
Fullerton, CA 92831, USA

Abstract

This work-in-progress (WIP) activity explores the potential of a supplementary student resource that involves setting up an online conglomeration of current and applicable topics for a course from the latest journals and publications to which students contribute, edit, and update as part of their class assignments and other course deliverables. The supplementary student resource described above was implemented in two engineering courses; the paper discusses: detailed implementation, pedagogical approach, and results of the measures taken to evaluate and assess the student benefits.

I. Introduction

Commercial publishing of textbooks is often a lengthy process. After the author decides on a topic of expertise, a thorough analysis of journals and conference proceedings pertaining to the topic is conducted and the author then elaborates on the findings published therein. This takes anywhere from 12 – 24 months based on the pace at which they work. After the book manuscript is complete it takes an additional 18 to 24 months before the actual book hits the shelves. Because of this time consuming process, even though the book contains findings from well noted and cited publications, the findings are now at least 2- 3 years old. Instead of having students use just texts that contain research findings that are already 2 – 3 years old, why not let them progressively built their subject knowledge from the latest journals and publications directly?

II. Instructional Development - *CoursePedia* for Engineering Courses

The potential of a supplementary student resource, that involves setting up an online conglomeration of current and applicable topics for a course from the latest journals and publications to which students contribute, edit, and update as part of their class assignments and other course deliverables, is explored.

For the following discussion, *EGCP 281(Designing with VHDL)* course in the Computer Engineering program at California State University, Fullerton is used as an example. However, the proposed methodology for instruction development can be applied to other courses in engineering as well.

(a) Implementation Process

1) As and when topics are covered during the course of a semester, the instructor for *EGCP 281* course assigns a project that involves a literature review on a particular course topic as part of homework, mid-terms, or final. Once students decide on a topic for the assignment approved by the instructor, they conduct a thorough review of the latest publications utilizing the online resources of the university library such as the IEEE Xplore and submit a formal report with relevant references.

2) The instructor for *EGCP 281* course would then compile and link these reports to the course webpage, which in turn is linked to the *ECS CoursePedia*, the online encyclopedia for *College of Engineering and Computer Science (ECS)*.

A sample website layout to illustrate the above described concept is shown below.

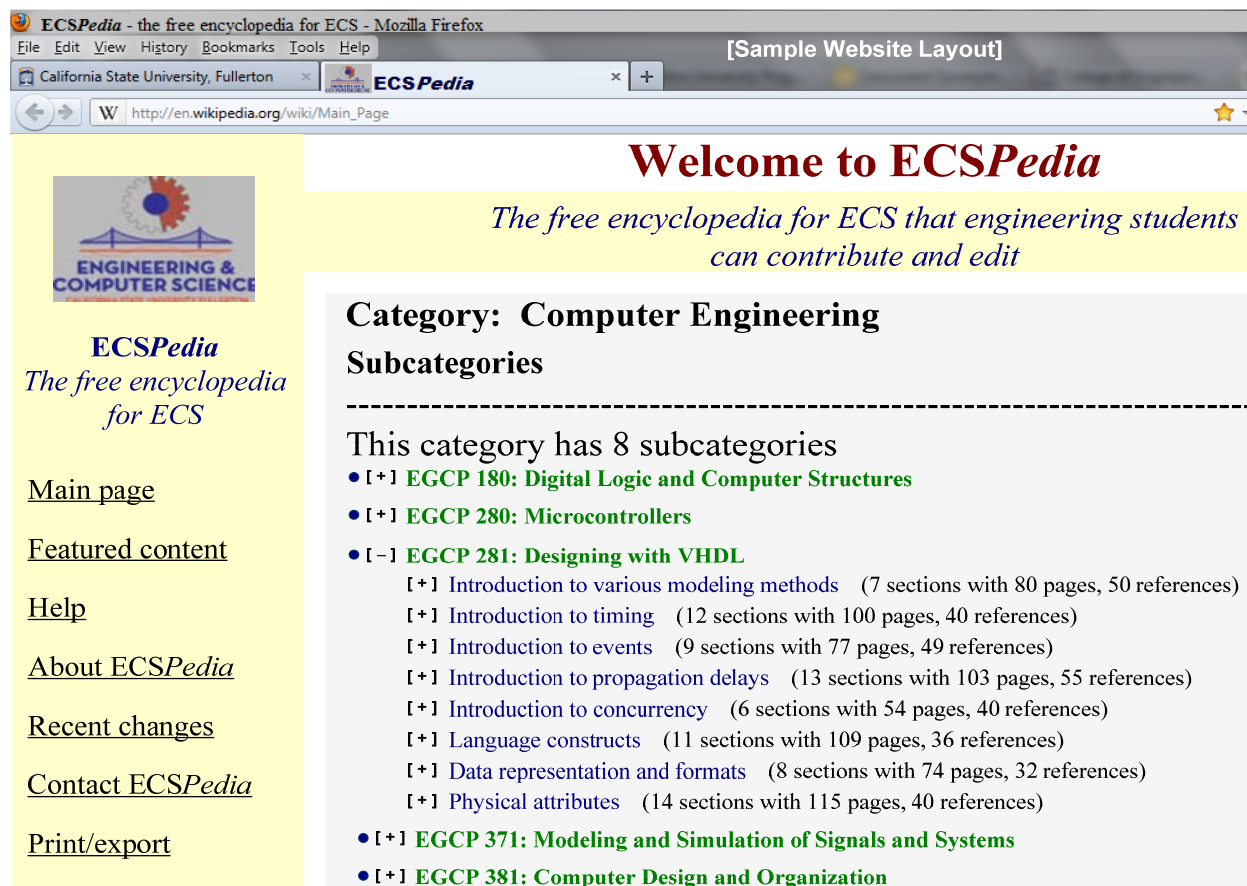

Fig. 1. Sample website layout for *CoursePedia* activity

3) As all instructors teaching *EGCP 281* course continue the process as described in step 1 and 2 every semester, the information listed on the course webpage is constantly edited and updated by students with its contents remaining current as it includes data from the latest peer-reviewed publications in the field.

III. *CoursePedia* Implementation, Student Feedback and Analysis (Spring 2011 and Fall 2012)

(a) Implementation

The supplementary student resource described above, *CoursePedia*, was adopted in engineering courses to ascertain its effectiveness. In Spring 2012, students in EGCP 441 course – *Advanced Electronics for Computer Engineering* (total enrollment: 11, one section) were asked to submit a research paper on topics in nanoelectronic technologies as part of the final exam for the course. For the paper, students were asked to conduct a thorough review of the latest publications utilizing resources such as the IEEE Xplore and submit the paper with relevant references. In Fall 2012, students in EGCP 456 course – *Introduction to Logic Design in Nanotechnology* (total enrollment: 16, one section) were provided with the papers on nanoelectronic technologies submitted by students from EGCP 441 class (Spring 2012) and were asked to edit and update them with the latest findings as part of their final exam for the course. Papers from the previous batch of students provided the current batch a better starting point for their research on the assigned topic. Reports submitted from the Fall 2012 EGCP 456 batch will next be utilized by students in Spring 2013 EGCP 441 course.

Using the above described student centered activity, it is anticipated that the assimilated information content will not only serve as a supplementary resource, but one that is superior in every respect as the subject matter is current with findings reported in the latest journals and publications . As the contributions are from students themselves it facilitates better comprehension and increased retention.

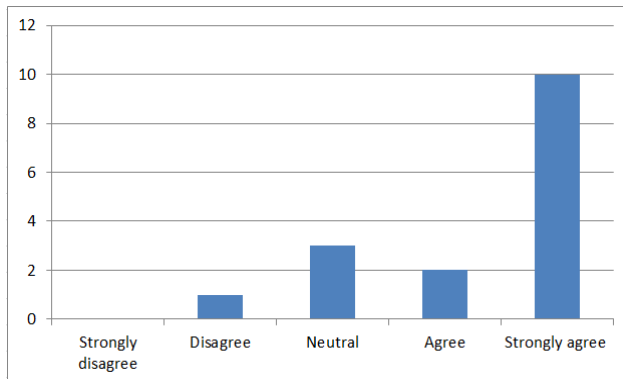

“The research papers from your peers provided a better understanding of the topic that was assigned to you as part of the final for EGCP 456 course”

Fig. 2(a): Student survey question 1

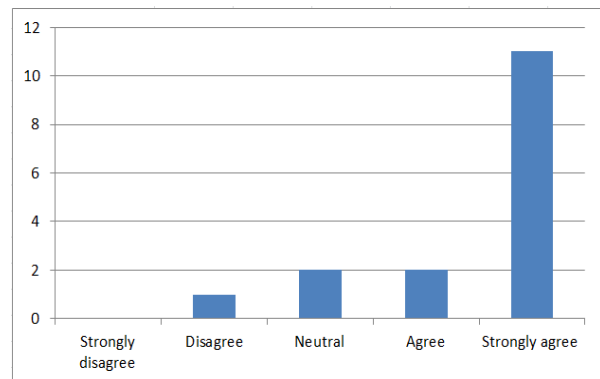

“The research papers from your peers provided a better starting point for the research on your topic that was assigned to you as part of the final for EGCP 456 course”

Fig. 2(b): Student survey question 2

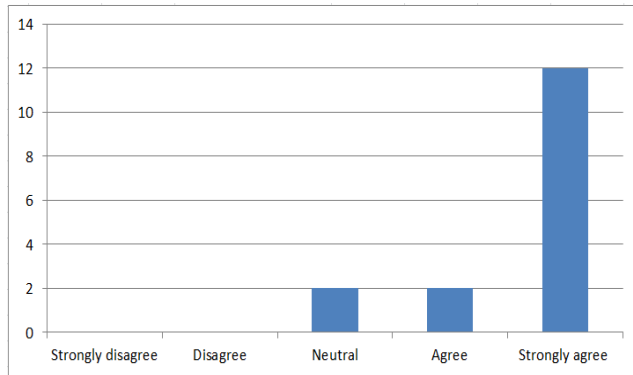

“Research papers progressively edited and updated by peers each semester can increase your knowledge of the subject matter as it is more current”

Fig. 2(c): Student survey question 3

topic on nanoelectronics was improved. Figure 2(b) summarizes the student response to the second question in survey, *“The research papers from your peers provided a better starting point for the research on your topic that was assigned to you as part of the final for EGCP 456 course.”* Approximately 81% of the students agree that the research papers from their peers helped them quickly grasp the concept compared to traditional resources such as journals. Figure 2(c) summarizes the student response to the third question in survey, *“Research papers progressively edited and updated by peers each semester can increase your knowledge of the subject matter as it is more current.”* Approximately 88% students believed that research papers that are progressively edited and updated can serve as a good supplementary resource that can increase their knowledge of the subject matter as it contains the latest findings reported in the latest journals and publications. Some of the student inputs to the free-response question *“What suggestions do you have for improving the CoursePedia in the future?”* were as follows:

- *“I thought that the CoursePedia was really helpful. It helped me better understand my topic and overall got a better knowledge of the topic.”*
- *“Great tool for learning.”*
- *“An archive database of the various updates done year after year would greatly enhance the understanding on the progression and growth of the particular technology researched.”*
- *“Some topics in selection did not seem to show improvement over the last year or didn’t make it public which made it somewhat difficult to come up with new information.”*
- *“I don’t think there are any significant improvements that can be made. It is very straightforward. We simply take a paper written by a previous student, and update it with more up-to-date information.”*
- *“The only problem I had was, I was unable to find some of the previous reports information. The other person may have had more classes already but I couldn’t “verify” his information which made it a little more of a challenge.”*

(b) Student Feedback and Analysis

A student survey was constructed to measure students’ perceptions of the *CoursePedia* activity in Fall 2012 EGCP 456 class. The survey included three questions with responses: strongly disagree, disagree, neutral, agree, and strongly agree along with a question with free-response answer.

Figure 2(a) summarizes the student response to the first question in survey, *“The research papers from your peers provided a better understanding of the topic that was assigned to you as part of the final for EGCP 456 course.”* Approximately 75% of the students agree that their understanding of the assigned

Author plans to incorporate the constructive suggestions from students and modify instructions for the *CoursePedia* assignment including:

- Providing students with an exhaustive database and resources that they can use to search for the latest findings on the topics assigned to them;
- Providing students strict format guidelines including referencing.

III. Conclusion

A supplementary student resource, *CoursePedia*, that involves setting up an online conglomeration of current and applicable topics for a course from the latest journals and publications to which students contribute, edit, and update as part of their class assignments and other course deliverables was presented. It is anticipated that *CoursePedia* will not only serve as a supplementary resource, but one that is superior in every respect as the subject matter is current with findings reported in the latest journals and publications . As the contributions are from students themselves it facilitates better comprehension and increased retention. Implementation, student feedback and analysis of *CoursePedia*, which was adopted in two engineering courses to ascertain its effectiveness, were also discussed. The analysis of the student feedback showed that the supplementary student resource *CoursePedia* was effective in improving the student learning process. However, classes of larger sizes are needed in the future to further study its effectiveness.

Summer Research Opportunity for University-Community College-High school Partnership: A Great Motivation for Engineering Education Pathways

**Binod Tiwari, Ph.D., P.E.
Associate Professor and Acting Chair
Civil and Environmental Engineering Department
California State University, Fullerton**

Abstract

Although it has been identified as one of the high impact practices, involving undergraduate students in the faculty-student collaborative research has not been practiced with expected success. The situation is worse for community college and high school students. This paper includes an experience of the author in implementing a model that includes community college and high school students in summer research opportunities with students from master's degree granting institutions. The study shows that involving high school and community college students in the university level research motivates students to pursue engineering degree and exhibit high performance.

Introduction

Although the US government is putting lots of emphasis in engineering education, the number of students enrollment in engineering majors has not increased as expected. For example, in Fall 2012, California State University Fullerton had the highest enrollment in the California State University system with 32,328 enrolled undergraduate students. Out of this, students enrolled in the engineering and computer science major were only 6.2% (CSUF, 2012)¹. Likewise, out of 5,349 enrolled post-bachelor degree students, 12.8% were in engineering and computer science majors. Although the graduation rate of the entire university is 64%, the graduation rate of the engineering and computer science students is only 40%. The 4-year graduation rate of transfer students in the engineering and computer science major is only 41%. These statistics show that the student enrollment in engineering majors is significantly low compared to the other majors. In addition, the graduation rate of the engineering students is much lower compared to the students in other majors. Despite the high demand of engineers nationwide, the students in the high schools and community colleges are not sufficiently motivated to pursue engineering degree. One of the possible reasons for this is the misunderstanding about the level of difficulty regarding engineering education among the high school and community college students. Students who are exposed to hands-on experience are much more attracted to engineering education compared to those who aren't. To give opportunities to high school and community college students in university level research, college of engineering and computer science at CSU Fullerton has been working in collaboration with various community colleges and high schools through summer research opportunities. The first cohort group started in summer 2009, with a total of 5 community college students from Cypress College, CA. The second cohort group included 6 students from numerous community colleges in CA and several students from local high schools. The author supervised 3 students in two different projects for the first cohort group,

whereas two high school students and three community college students were involved in two other projects for the second cohort group. This article includes the experience of the author through those collaborative efforts.

Research Model

Each of the research groups working under the author included a graduate student, a senior/junior student, a community college student and a high school student. In addition to a weekly presentation/seminar, the author mostly communicated with the graduate student. The graduate students involved in the project took leadership and delegated the experimental/testing tasks to senior students. The community college and high school students helped the seniors in performing the experiments. The graduate students, with the help of all other students performed data analysis for the weekly presentation. Each student was required to present his/her part of the work during those weekly presentations. This approach gave ownership of the research outcome to individual students and each student felt equal responsibility to his/her part of the research. Combinations of those results were compiled as the overall research output.

Research Projects

Due to the involvement of community college students for a short duration, i.e. 10 weeks, students were involved in a part of some major research projects mentored by the author. These projects and the results of 10-week long study are summarized below.

Intelligent Mapping Project

As a part of the author's main goal to develop a risk management map of the university, two community college students from the Cypress College were grouped with a freshman and a senior student at CSU Fullerton in summer 2009. These students were led by a graduate student. The community college students were funded by a STEM grant awarded to the community college by the Department of Education. The group of students surveyed a part of the university, using various surveying equipment such as total station and GPS. The group prepared the 3-dimensional map of the area they surveyed using the GIS tools. Shown in Figure 1 is the map prepared by those students. The community college students were highly motivated in the discipline and enrolled into the bachelor's degree program in civil engineering at two highly renowned universities in southern California. Both of them received highly competitive stipends. Those students completed their BS in civil engineering with excellent performance. The freshman at the time of research is now completing his BS in civil engineering from the CSU Fullerton with cum laude. Other students involved in the project graduated and are working in the Orange County as civil engineers. Another group of students continued the project and prepared map of the entire university. The completed project owned the third place in the international google mapping competition, 2011 (google, 2012)².



Figure 1: Left: Students involved in the intelligent mapping project; Right: Part of the intelligent mapping project completed by the first cohort group of students.

Impact of Earthquake on Slope Failure

In order to evaluate the effect of earthquake on the stability of slopes, a community college student from Cypress College, California, was involved in 2009 with a senior and a graduate student at CSUF. This group of students measured the strength of soil and performed the sensitivity study, using commercially available software, to evaluate the influence of the magnitude of earthquake shaking and steepness of slope on slope failure. The community college student was sponsored by the STEM grant explained above whereas the CSUF students were funded by the author's research grant. The students involved in this project designed a Plexiglas container, fabricated them and prepared a model soil slope in the container for experimental simulation in a shake table. Shown in Figure 2 is the slope before and after seismic shaking. After the internship, the community college student pursued BS degree in civil engineering in a university in southern California and has completed his degree recently with an outstanding GPA. The senior student from CSUF is now doing PhD in civil engineering, while the graduate student is working in a reputed engineering company after getting his professional engineering license.



Figure 2: Left: Model slope before shaking with earthquake load; Right: Collapsed slope after shaking it with earthquake magnitude slightly higher than the Northridge Earthquake.

Use of Recycled Materials in Construction

A community College student from Santiago Canyon College joined a group of 3 seniors, a high school student, and a graduate student in summer 2012 to evaluate the potential of reusing scrap rubber tires in civil engineering construction. The community college student was funded with STEM grant whereas the CSUF students were funded with LSAMP scholarship and NSF Graduate Research Fellowship. The high school student joined as a part of their co-curricular internship opportunities. The group found that the shredded rubber tires can be shredded into the desired size to enhance the load carrying capacity of weak soils. The study resulted into 7 presentations and a peer reviewed publication. Shown in Figure 3 are the photographs of rubber tire mixed soil and increase in density of soil after mixing shredded tire, 10% by weight. The CSUF seniors are graduating this year and pursuing graduate study whereas the CSUF graduate student is pursuing PhD at a renowned US university. The community college student is applying to transfer into a civil engineering program, whereas the high school student got admission into an engineering program at the university of her first-choice.

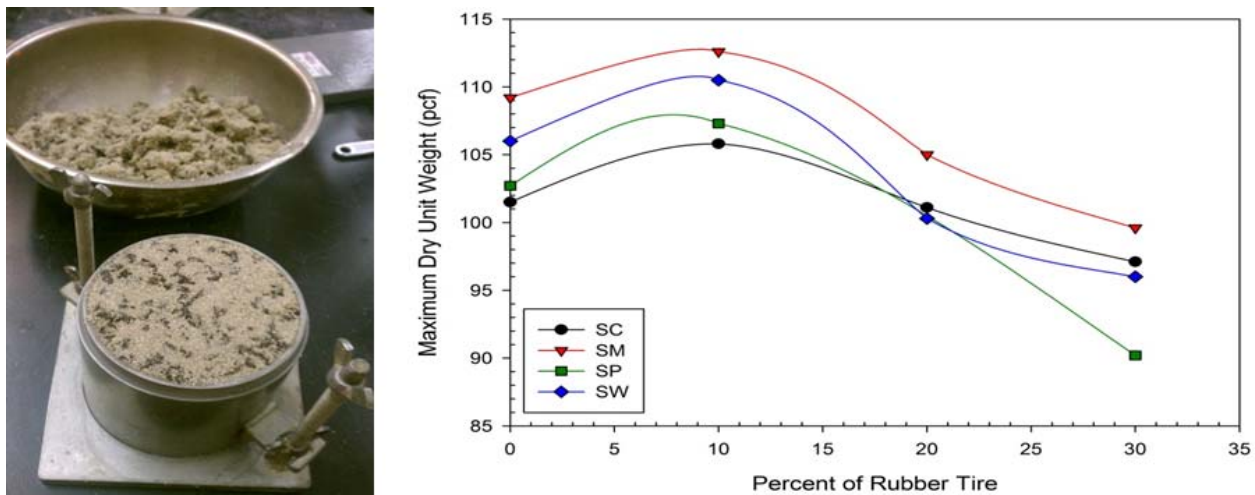

Figure 3: Left: Mixture of soil and shredded rubber tire; Right: Change in density of soil after mixing various amounts of rubber tires in four different types of soil.

Influence of Antecedent Rainfall on Earthquake Triggered Landslides

Two community college students and a high school student collaborated with an undergraduate and a graduate student at CSUF to investigate the influence of antecedent rainfall in triggering landslides during strong earthquakes. The research result showed that duration and magnitude of earthquake plays important roles in triggering large landslides. The community college students were sponsored by the STEM grant whereas the CSUF students were sponsored by the research fund of the author. The high school student undertook research as a required internship. Shown in Figure 4 is the experimental modeling of the slope before setting on the shake table. The CSUF students graduated and are working in some reputed engineering companies, whereas the

community college students have transferred to engineering program at renowned universities in California.



Figure 4: Left: Seepage of rainwater in the soil strata to cause softening in soil; Right: Ponding water and soil erosion after excessive rainfall.

Impact of Collaborative Research in Engineering Education

The collaborative research didn't only benefit the community college students, but it also provided a leadership skill and helping hands for graduate and senior students at CSUF. The team-work not only motivated the students to pursue engineering as their academic major, but also enhanced their enthusiasm to complete a portion of a big project so that they could present it in a conference/workshop. Due to the hands-on research experience, the students were able to understand the application of science and math education they completed thus far in engineering projects. Students believed that due to the collaborative research, they were able to generate and analyze the data, and prepare scientific presentations; which would not have been possible otherwise. The students obtained excellent information to write in their plan of study while submitting their applications for admission in the universities. In addition, they could contact the author anytime in their career, whenever they need a reference for future use. More importantly, the community college and high school students received an exposure to university level education and research, which not only motivated them to pursue higher education but also helped them to streamline their academic goal. The cohort group 2 students are presented in Figure 5.



Figure 5: Second cohort group: 2 high school students and 3 community college students.

Presented in Table 1 are the interest level and current position of the community college and high school students involved in various summer research projects, explained above. The interest levels were obtained from the applications the students submitted prior to their acceptance in the project. According to the information provided by the community college and high school students in their application, those students never worked in group project before these summer projects. As observed in Table 1, although the interest of students to pursue engineering major was not that high before they joined the research project, all of them are now enrolled in engineering majors at different universities or have completed engineering degree with excellent GPA. Likewise, academic performance of the CSUF students also increased after being involved in the summer research (Table 2). Publication record and leadership skill they obtained from these projects were beneficial to the students in accepting various leadership roles in different engineering student organizations, obtaining highest ranks in various local and national level research competitions and getting scholarships for further research. Out of 9 students involved in these research projects, 6 students received various fellowships for undergraduate and graduate level studies including the NSF Graduate Research Fellowship. Students believe that it was possible due to the summer research opportunities.

Table 1: Interest level and current situation of the community college and high school students, involved in the summer research (10 - the highest)

Student no.	Prior Institution	Interest in engineering prior to summer research (1-10)	Current Position	Number of presentations
1	Cypress College	6	Completed BS in civil engineering from UC Irvine	1
2	Cypress College	5	Completed BS in civil engineering from University of Southern California	1
3	Cypress College	4	Completed BS in civil engineering from California Polytechnic University Pomona	1
4	Cypress College	6	Enrolled for BS in mechanical engineering at UC San Diego	1
5	Santiago Canyon College	4	Applying for transfer into an engineering major	1
6	Santiago Canyon College	4	Applying for transfer into an engineering major	1
7	High School	4	Admitted into an engineering major	0
8	High School	5	Admitted into an engineering major at Duke University	0

Table 2: Prior and current situation of the CSUF students who were involved in the summer research

Student no.	Level prior to summer research	Current Position	Number of presentations / publication
1	Freshman	Completed BS in Civil Engineering (CE) with cum laude	1
2	Senior	Completed BS in CE and working as an engineer	0/1
3	Graduate	Completed MS in CE and working as an engineer	0/1
4	Senior	Completed BS in CE and pursuing MS in CE	4/3
5	Senior	Completed BS in CE and pursuing MS in CE	3/3
6	Senior	Completed BS in CE and pursuing MS in CE	3/3
7	Senior	Completed BS in CE and pursuing MS in CE	2/1
8	Graduate	Completed MS in CE and working as an engineer	5/4
9	Graduate	Completed MS in CE and doing PhD in CE at Virginia Tech	13/12

Summary and Conclusion

Six community college and two high school students were involved in four different university level collaborative research projects at CSU Fullerton. The students from CSU Fullerton ranged from freshman to graduate level. CSU Fullerton students were funded with the author's research fund whereas the community college students were funded with STEM Summer Research Funds. Although the community college and high school students were not thinking to pursue admission into an engineering major prior to the summer research project, all of those students chose engineering as a their academic career. On the other hand, the CSU Fullerton students also got benefit with the collaborative research and pursued graduate studies in PhD and master's level. According to the students who took part in the collaborative research projects, they would not have considered engineering as their career goal if they were not provided with the summer research opportunity. Therefore, providing summer research opportunities to high school and community college students and letting them work in a team with seniors and graduate students in an university broadens the understanding of those students regarding engineering education and help the nation to enhance the quality and quantity of students in engineering education.

References

1. CSUF (2012). Office of Analytical studies and Research. Census data 2012.
2. Google.inc (2012). <https://sites.google.com/site/mapyourworldcommunity/competition/2012-us-ca-universities>

Engaging Engineering Students in Research from Early Stage of Their Student Career

Binod Tiwari, Ph.D., P.E.
Associate Professor and Acting Chair
Civil and Environmental Engineering Department
California State University, Fullerton

Abstract

Engineering education in the USA has significantly been controlled by the accreditation agency. As a result, classroom education is paid much more attention compared to the hands-on or research activities. In this study, a select group of engineering students were involved in faculty-student collaborative research activities in different stages of their academic standings and their progresses were monitored. The study result shows that students can improve their academic performance significantly after being involved in faculty-student research activities. Moreover, students, involved in research, showed more leadership skill as well as advancement to graduate studies.

Introduction

Undergraduate level engineering courses in US are mainly controlled by the accreditation criteria such as the one set by the ABET (ABET, 2013)¹. The number of semester units that the students have to take to graduate bachelor's degree in engineering mainly ranges from approximately 120 to 140 units depending on the program's requirement for math, science and engineering courses as well as the general education courses. Time taken by a student to graduate also depends on the performance of students in various levels of their studies. For example, if a student fails in lower level math, science and engineering courses, he/she cannot take upper level courses that require to have passing grades in those lower level courses. Therefore, average graduation year of 6 years in some engineering programs is not surprising. Moreover, due to monotonous nature of some theoretical math and science courses, students sometimes feel lost from the beginning of their college career. Although they understand the practical application of those science and math courses when they take engineering courses and perform well in their engineering courses, many students struggle in the lower level math and science courses. One way to motivate and engage these students is to provide them opportunities of engineering research activities so that they can correlate the theory based classes with respective practical implications.

With the Fall 2012 undergraduate enrollment of 32,328, California State University Fullerton is the largest university in the California State University system in terms of student enrollment. Out of 32,328 undergraduate students, students enrolled in engineering and computer science major were only 6.2% (CSUF, 2012)². Likewise, out of 5,349 enrolled post-bachelor degree students, 12.8% were in engineering and computer science majors. Although the graduation rate of the entire university is 64%, the graduation rate of the engineering and computer science students is only 40%. These statistics shows that the number of students enrollment in engineering majors is significantly low compared to the other majors. In addition, the graduation

rate of the engineering students is much lower than the students in other majors. This could be attributed to the high dropout rate in the freshman and sophomore year, where the students are taking math and science courses. Involving students in hands-on experience could be helpful in increasing the retention rate. If the lower classmates (freshman and sophomore level) are paired with the upper classmates (junior and senior level) and graduate students in research, the students can get benefit of being involved in research as well as the mentorship. Moreover, getting opportunities for collecting and analyzing data as well as presenting the research results in different academic avenues provide the students confidence in understanding their regular classes. On the contrary, being involved in such extra-curricular activities and spending several hours in research may affect adversely in their regular classroom performance. To evaluate whether it is beneficial for students to be involved in research from their early stage of undergraduate studies, 61 students were involved in various research projects in collaboration with the author. Students were chosen from different levels of their undergraduate level studies, ranging from sophomore to senior, and GPAs ranging from 2.5 through 3.9. To increase diversity, priority was given to have students from different ethnic backgrounds as well as gender. Parameters chosen to assess the success of the program were - GPA, awards and scholarships, conference presentation, publication, and progress to graduate level studies. Only the data pertinent to undergraduate students are considered in this study, although graduate students were also involved in this study.

Background of Selected Students

Out of 61 students chosen for this study, percentage of sophomore, junior and senior level students were 5, 36, and 59, respectively. 35% of those students were chosen from the students with Hispanic background. Likewise, 21% of those students were female.

Nature of the Research Projects

Students were involved in 12 different research projects. The number of students involved in those projects ranged from 2 to 5, depending on the nature of the project. Moreover, majority of the research projects involved students from all three levels i.e. sophomore, junior and senior. In addition to this, there were two national level competitions that the students participated every year. The pilot study started from Summer 2007 and ended in Fall 2012. Majority of those research projects were fully or partially funded. In terms of student involvement, students involved in their first year were involved either through volunteer interest or for academic credit, whereas the students involved for multiple years were supported through the research assistantship funded by the author's grant projects.

Results of the Study

The effectiveness of the study was evaluated with different criteria, explained below.

Class Grades

Based on the study, the performance of students in terms of GPA increased consistently for the students in all levels. The sophomore level students could raise their GPA by 0.07 (at the scale of

4.0), whereas the junior and senior could raise their GPA by 0.05 and 0.04, respectively. Average GPA those students, selected from each level, were higher than 3.0 at graduation.

Written and Oral Communication Skills

Improvement in the written and oral communication skills were evaluated based on the number of presentations made by the students in various local as well as national/international level conferences and co-authorship in various journal articles as well as conference proceedings. Students involved from sophomore level could make 13 conference presentations, whereas the students involved in junior and senior level could make 33 and 22 presentations, respectively. The students involved in sophomore level, junior level a senior level could co-author 17, 15, and 8 articles, respectively, in various peer reviewed avenues. It should be noted here that out of 55 peer-reviewed publications that the author co-authored in this study period, 45% were co-authored with undergraduate students involved in the study, whereas 9% and 11% of those publications were coauthored with graduate students and a group of graduate and undergraduate students, respectively. All of those undergraduate students were involved in this study.

Scholarships and Grants

One among the indirect benefits of being involved in research and having publication is being able to receive various scholarships and grants. Students having publication, presentation and leadership skill are evaluated highly while reviewing the applications for grants/scholarships. Students involved in their sophomore level received 2 small scholarships (<\$1,000), 6 moderate level scholarships (\$1,000-\$5,000), and 3 major level scholarship (>\$5,000). Likewise, students involved in their junior year received 4 small, 8 moderate, and 8 major level scholarships. The students involved in their senior year were also able to receive 4 moderate and 1 major level scholarships. Three of these students received national level scholarships such as the Eisenhower Transportation Fellowship and the National Science Foundation Graduate Research Fellowship (NSFGRF) with the amount higher than \$10,000, including a \$121,000 NSFGRF. Those students were role models for the junior students.

Involvement in National and Local Level Student Competitions

Students involved in the research were also involved in various national and local level student research/project competitions organized by the national societies such as the American Society of Civil Engineers (ASCE). These were volunteer activities, enthusiastically chosen by the students. Through these competitions, students got opportunities to work in a group, design and implement some engineering projects, in addition to interacting with students and professional nation-wide. These activities helped those students in developing the leadership skills. Students involved in the sophomore level participated in 2 regional and 7 national level professional competitions. Likewise, students involved in their junior year participated in 4 regional and 7 national competitions, whereas the students who joined in their senior year participated in 7 regional competitions only. The travels of those students were supported by the grants provided by the sponsoring organizations such as ASCE and the university resources.

Post-graduation Path

The post-graduation career paths were tracked for all of these students. Record shows that the students chose two major career paths – engineering practice or graduate studies, or both. Some students joined graduate schools while working in the professional field, whereas some students moved further to PhD level studies. Among those who joined in the sophomore year, 1 student enrolled into graduate study in the same field to PhD level, and 2 joined professional practice. However, both of those students enrolled and finished their master’s degree while working. Among the students who started research in their junior year, 11 joined professional field as engineers, 6 pursued graduate study, and 5 completed their master’s degree while working as professional engineers. Out of those students who joined research in their senior year, 18 joined the professional practice, 4 pursued graduate study, whereas 14 completed their master’s degree in civil engineering while working as practicing civil engineers.

Summary and Conclusion

In past 5 years, sixty one students having different academic and ethnic background were selected and involved in various stages of faculty-student collaborative research activities. The progress of students shows that the students involved in research from the early stages of their college years, especially from the sophomore or junior level, could improve their academic performance significantly, engage into various national and regional competitions, acquire various fellowships/scholarships and have academic publications. These achievements motivated those students to perform well in their professional field, as well as moving forward to graduate level studies.

References

1. ABET (2013). [Http://www.abet.org/](http://www.abet.org/)
2. CSUF (2012). Office of Analytical studies and Research. Census data 2012.

Evaluating the Impact of ECS Academic Catalyst for Excellence (ACE) Scholarship Program

Kiran George

Computer Engineering Program
California State University, Fullerton
Fullerton, CA 92831, USA

Abstract

Recent research strongly suggests that engineering education loses about 53% of undergraduate students of which roughly 40% switch to non-science fields. Similarly, the out migration from the College of Engineering and Computer Science (ECS) at California State University, Fullerton (CSUF) has been profound. In 2010 with funding availed from the NSF, ECS at CSUF established the ECS Academic Catalyst for Excellence (ACE) Scholarship Program designed to reverse its historical legacy of high student attrition. This program awards scholarships to ECS students over the 5-year period of the project and leverages a well-established network of ECS and University student services to support cohorts of ACE scholars (recipients of the ACE scholarship) majoring in ECS majors. The ECS ACE scholarship program provides tuition scholarships and a myriad of support services ranging from peer mentoring to priority registration. The paper presents detailed evaluation and assessment of the scholarship program using the following measures: a) Attitude and enthusiasm of students towards the ECS ACE scholarship program activities; b) Academic self-efficacy, and STEM interest and motivation based on the assessments of ACE scholars; c) Qualitative measure of program effectiveness based on: GPA of ACE scholars when compared to traditional students of similar background not supported by the ACE program; d) Impact of working hours on the ACE scholars' academic performance; e) Correlation between the scholarship amount and ACE scholars' academic performance.

I. Introduction

Students planning to major in science or engineering make up approximately 30% of all incoming college students, however, the attrition rate is the highest among all undergraduate disciplines¹. In a broad national study of attrition, it was reported that engineering education loses about 53% of undergraduate students of which roughly 40% switch to non-science fields². The most attrition occurs during the first two years³ and therefore institutional retention efforts must be focused on the needs of freshmen and sophomores to achieve more equitable attainment rates. The attrition rate in the College of Engineering and Computer Science (ECS) at California State University, Fullerton (CSUF) is profound and similar to the national trend. In Spring 2010 with the funding availed from the NSF, ECS at CSUF established the ECS Academic Catalyst for Excellence (ACE) Scholarship Program designed to reverse its historical legacy of high student attrition. This program that awards scholarships to ECS students over the 5 year period of the project and leverages a well-established network of ECS and University student services to

support ACE scholars (recipients of the ACE scholarship) majoring in ECS majors. Currently there are 23 participants in the ACE scholarship program.

Section II briefly describes the guiding principle and program implementation. Detailed evaluation and assessment of the scholarship provided in section III and conclusion in section IV.

II. ECS Academic Catalyst for Excellence (ACE) Scholarship Program

(a) Guiding Principle of the ECS ACE Program: The guiding principle for the ACE scholarship distribution plan is to provide 4 years of continuous financial support to a maximum number of incoming freshmen and sophomores as research suggests that the most attrition occurs during the first two years of college.

(b) Program Implementation: ECS ACE program is a comprehensive educational support system designed to increase student retention. The scholarship serves as a catalyst that allows students to focus diligently on their academics. The ECS ACE scholarship program targets academically promising but economically disadvantaged ECS students with special emphasis on first generation college students and students underrepresented in the STEM fields. The program leverages a well-established network of ECS and University student services to ACE scholars to provide a myriad of support services ranging from peer mentoring to priority registration. Scholars are selected on the basis of their academic potential and financial need. Based on the class level, an ACE Scholar receives tuition scholarship for a maximum of seven consecutive semesters (up to \$2000 per semester). The academic standing of ACE scholars is evaluated every semester and necessary remedial steps are taken if their academic performance is not up to par.

(c) ECS and University Support Systems Utilized for the ACE Program: Instead of creating new support systems for the program, existing and well-established network of ECS and University support systems such as Center for Academic Support in Engineering and Computer Science (CASECS), University Learning Center (ULC), Center for Internships and Service-Learning (CISL), and CSUF Career Center were leveraged to ensure the success of the ACE program.

(d) ACE Scholar Support Services: In order to improve educational opportunities and increase retention of ECS students following support services were incorporated into the ACE program:

- ***One-on-One Peer Mentoring/Tutoring*** – Three peer mentors/tutors were hired to provide mentoring and tutoring services to the ACE scholars as and when they need it. However, scholars were stipulated to meet with the peer mentors/tutors once in three weeks to update the program on their academic performance, participation in various program activities and career goals. The ACE mentors/tutors report back to the ACE program director on a weekly basis. This feedback gives the ACE program a first-hand analysis of the ACE scholars, their performance and standing in the program.
- ***Professional Development Workshops*** - In collaboration with the *Career Center*, ACE program provides exclusive resume writing exercises, interview practice sessions, career exploration guidance, information on graduate school transfers, job fairs, etc.

- **Academic Internships and Job Fairs** - CASECS in collaboration with the CISL, Career Center, ECS Dean's Affiliates and departmental industry advisory boards is expanding the summer internship opportunities for engineering and computer science juniors and seniors; it also assists with career placement through on-campus job fairs.
- **Speaker Series** - The ACE program has been organizing speaker series for ACE scholars several times a year with speakers who provide insight and information on careers in engineering and computer science.
- **Academic Counseling** - ACE scholars automatically become CASECS members. Academic counselors in CASECS work with the ACE scholars to guide them from acceptance to graduation and career placement.
- **Priority Registration** – Through CASECS, ACE scholars' are given priority to register for classes.

(e) Scholarship Remedial Process: The academic standing of ACE scholars is evaluated on their semester grades, and feedback from their mentors and academic counselors who gauge the scholars for motivation and ability to manage time and resources. If scholars do not meet the minimum retention criteria due to a deficiency in GPA, the scholar is placed on scholarship probation for a semester with mandatory peer tutoring/mentoring. The scholarship is withdrawn the next semester following the probationary period if the student still does not meet the retention criteria.

III. Program Assessment and Evaluation

The program is currently employing the following assessment techniques to measure its effectiveness: a) Attitude and enthusiasm of students towards the ECS ACE scholarship program activities; b) Academic self-efficacy, STEM interest and motivation based on the assessments of ACE scholars; c) Qualitative measure of program effectiveness based on GPA of ACE scholars when compared to traditional students of similar background not supported by the ACE program; d) Impact of working hours on the ACE scholars' academic performance; e) Correlation between the scholarship amount and ACE scholars' academic performance.

(a) Attitude and enthusiasm of students towards the ECS ACE scholarship program activities

The attitude and enthusiasm of ACE scholars towards the ECS ACE scholarship program was used as the principal operational measure of effectiveness. In Fall 2012, all 23 ACE scholars in the program were asked to complete a survey during their meeting with the tutors/mentors. The survey included two questions with responses: strongly disagree, disagree, neutral, agree, strongly agree along with one question with free-response answer.

Figure 1(a) summarizes the student response to the first question in survey, "*The scholarship from the ACE program helps me cover my "unmet" financial need and allows me to focus diligently on academics.*" Only 70% of the scholarship recipients agree that the program helps them cover their "unmet" financial need. One of the primary contributing factors for this is the difference in the scholarship amounts according to the recipient's grade level at the time of the award (freshmen and sophomores are awarded \$4000/year, whereas juniors and seniors are

awarded \$2000/year). The motivation to structure the awards in two tiers was based on facts that: a) most attrition occurs during the first two years in college; and b) good number of ECS are able to attain academic internship/job in their junior and senior year, which in turn reduces their financial need. In Fall 2012, only 10 freshmen/sophomores level scholarships were awarded. The program plans to analyze this data in detail and take necessary steps to address the need to provide adequate funds to meet the unmet financial need of juniors and seniors in the program.

The scholarship from the ACE program helps me cover my “unmet” financial need and allows me to focus diligently on academics.

The activities and support systems associated with the ACE program complement the instruction received through classroom lectures and will help me secure employment or transfer to a graduate program.

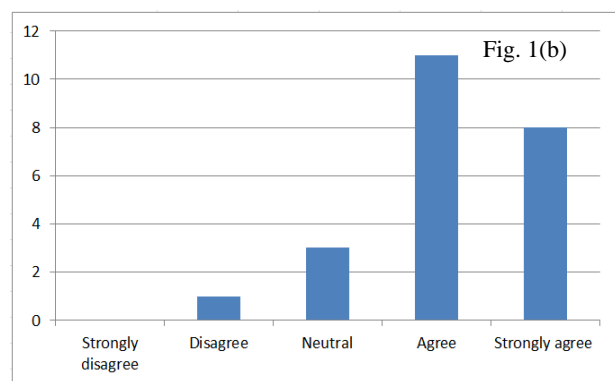
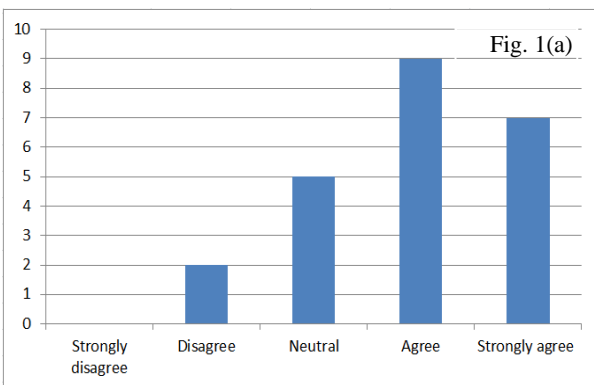

Figure 1: Student survey questions and feedback to measure attitude and enthusiasm of ACE scholars towards the ECS ACE scholarship program

Figure 1(b) summarizes the student response to the second question in survey, “*The activities and support systems associated with the ACE program complement the instruction received through classroom lectures and will help me secure employment or transfer to a graduate program.*” 83% of the scholarship recipients agree that the activities and support systems do have the intended impact.

(b) Academic self-efficacy, STEM interest and motivation based on the assessments of ACE scholars

Research has found that self-efficacy is positively related to grades in STEM courses along with intent to persist given that students enter courses with varying levels of fear and anxiety. The Baldwin Confidence Survey Form⁴, created to measure self-efficacy in STEM, was used for this study. Participants respond to statements on a five-point scale, ranging from strongly disagree to strongly agree. Statements are phrased both positively and negatively to increase reliability and reduce apathetic answers. Table 1 shows the pre and post STEM self-efficacy survey conducted to study the impact of ACE program and associated activities. It was observed from the data that there is a slight shift in the average score for most of the questions indicating the positive impact of the ACE program on the STEM self-efficacy of ACE scholars. This impact has to be

continuously tracked on a yearly basis to draw concrete conclusions and take remedial steps. The weekly reports from ACE mentors/tutors give a first-hand analysis of the ACE scholars, their performance and standing in the program. The reports reveal good indicators of STEM interest and motivation among ACE scholars, most of whom want to further pursue their master's degree in their respective disciplines.

Table 1. Pre and post STEM self-efficacy survey conducted to study the impact of ACE program and associated activities. The survey used a five-point scale, with responses ranging from strongly disagree (5 pts) to strongly agree (1 pt).

<i>Survey Question</i>	<i>Average score for the question during the first semester in the ACE program (pre STEM self-efficacy)</i>	<i>Average score for the question in Fall 2012 (post STEM self-efficacy)</i>
1. I am confident I have the ability to learn the material taught in STEM.	2.7	2.4
2. I am confident I can do well in STEM	2.6	2.2
3. I think I will do as well or better than other students in STEM	3.1	3.2
4. I don't think I will be successful in STEM	3.7	3.8
5. I am confident that I can understand the topics taught in STEM.	3.5	3.0
6. I believe that if I exert enough effort, I will be successful in STEM.	3.7	3.4
7. I feel like I don't know a lot about STEM compared to other students in this class.	3.5	3.9
8. Compared with other students in this class, I think I have good study skills.	2.8	2.7
9. Compared with other students in this class, I don't feel like I'm a good student.	3.4	3.8
10. I am confident I can do well on the lecture exams in STEM.	3.1	2.6
11. I am confident I can do well on labs in STEM.	2.9	2.6
12. I am confident I can do well in projects in STEM.	3.3	3.0
13. I think I will receive a C or better in STEM.	2.3	1.7
14. I don't think I will get a good grade in STEM.	3.6	3.9
15. I am confident that I could explain something learned in a class to another person.	2.5	2.4

(c) Qualitative measure of program effectiveness

Qualitative measure of program effectiveness based on the grade point average (GPA) of ACE scholars when compared to average GPA of students of similar background not supported by the ACE program in Table 2.

It can be observed from Table 2 that the average GPA's of ACE scholars in all the five majors are better than the average GPAs in their respective departments. However, the sample sizes for Computer engineering and Electrical engineering majors are too low to draw any meaningful conclusions.

Table 2: Qualitative measure of program effectiveness based on GPA

ECS Major	Fall 2012 Average GPA of ECS majors*	Fall 2012 Average GPA of ACE Scholars (number of ACE scholars)
Civil	2.78	2.96 ($N = 11$)
Computer	2.59	2.72 ($N = 2$)
Computer Science	2.93	3.51 ($N = 4$)
Electrical	2.79	2.91 ($N = 1$)
Mechanical	2.96	3.15 ($N = 5$)

*Data source: Office of Institutional Research and Analytical Studies, CSUF

(d) Impact of working hours on ACE scholars' academic performance

Impact of working hours on the ACE scholars' academic performance was studied. Following is the summary of the study:

- Modest negative *correlation* (r) (-0.37) was observed between number of working hours and the academic performance (GPA) of the scholars; *coefficient of determination* (r^2) indicates that 14% of variation in academic performance can be explained by the variation in the number of working hours.
- Average GPA of scholars with work commitments (off-campus and/or on-campus) was 3.04 and that of scholars without workout commitments was 3.12.
- Only two out of the 23 ACE scholars were engaged in a technical internship/job, therefore comparison of average GPA's of the scholars with and without technical internship/job commitment was statistically insignificant.

(e) Correlation between the scholarship amount and ACE scholars' academic performance

The ACE scholarship amount was structured in two tiers based on the recipient's grade level at the time of the award or renewal. Freshmen and sophomores are awarded \$4000/year, whereas juniors and seniors are awarded \$2000/year. Correlation between the scholarship amount and ACE scholars' academic performance (GPA) was studied and the following was the summary:

- Weak negative *correlation* (r) (-0.08) was observed between scholarship amount (\$2000 vs. \$1000) and the academic performance (GPA) of the scholars; *coefficient of determination* (r^2) indicates that only 1% of variation in academic performance can be explained by the variation amount of scholarship awarded.

- Average GPA of scholars with junior/senior level scholarship (\$1000) was 3.12 and that average GPA of scholars with freshmen/sophomores level scholarship (\$2000) was 3.05.

IV. Conclusion:

The paper describes the motivation, program implementation, and detailed program evaluation and assessment of ECS ACE scholarship program, designed to reverse its historical legacy of high student attrition at the College of Engineering and Computer Science (ECS) at California State University, Fullerton (CSUF). The program awards scholarships to ECS students over the 5 year period of the project and leverages a well-established network of ECS and University student services to support ACE scholars. The attitude and enthusiasm of ACE scholars towards the ECS ACE scholarship program was used as the principal operational measure of effectiveness. It was observed that only 70% of the scholarship recipients agree that the program helps them cover their “unmet” financial need; the two tier structure of the scholarship is considered as a primary contributing factor. Majority of the scholarship recipients agree that the activities and support systems do have the intended impact. Pre and post STEM self-efficacy surveys conducted to study the impact of ACE program and associated activities indicates a positive impact. The weekly reports from ACE mentors/tutors reveal good indicators of STEM interest and motivation among ACE scholars. Even though it was observed that the average GPA’s of ACE scholars in all the five majors are better than the average GPAs in their respective departments, the sample sizes for Computer engineering and Electrical engineering major are too low to draw any meaningful conclusions. Unlike expected, the off-campus and/or on-campus working hours and the scholarship amount was observed to have a minimal impact on the ACE scholars’ academic performance.

References

1. Committee on Prospering in the Global Economy of the 21st Century (US) & Committee on Science, Engineering, and Public Policy (US). (2007). *Rising Above the Gathering Storm: Energizing and Employing America for a Brighter Economic Future*. Washington, D.C.: The National Academies Press.
2. Astin, AW & Astin, H.S. (1992). *Final Report: Undergraduate Science Education: The Impact of Different College Environments on the Educational Pipeline in the Sciences*, Higher Education Research Institute, Graduate School of Education, UCLA.
3. Freeman, T.L. (2001). Recruiting and Retention Effectiveness. *Proceedings of the 2001 American Society for Engineering Education Annual Conference & Exposition*, Albuquerque, NM.
4. Baldwin, J. A., Ebert-May, D., & Burns, D. J. (1999). The development of a college biology self-efficacy instrument for nonmajors. *Science Education*, 83(4), 397-40.

Acknowledgments

This work was supported by the National Science Foundation grant DUE-0966068

Identifying At-Risk Students: How Use of Optional Study Materials and Collection of Graded Work Correlate with Academic Performance

**Vladimir I. Prodanov
EE Dept., California Polytechnic State University, San Luis Obispo**

Abstract

We report on a study designed to identify students at risk by monitoring certain academic behaviors. Two different approaches were implemented. The first one involves monitoring student access of optional homework problems. While this approach was successful in the early identification of students at-risk, optional homework (as opposed to mandatory one) degrades attainment of learning objectives. The second approach relies upon “counting” of uncollected work. Since no grades were posted, the only way for the students to keep track of their performance was to collect their work. Failure to collect graded work, we argue, is indicative of weak motivation, poor class attendance and poor attendance of office hours. In a class of 114 students, 29 students failed to collect at least one major graded work. Twenty-one of them had below-average class ranking and all students with final grades of F and D+ were part of the underperforming group of 21 students. We also studied the motivating impact of rank-performance plots. The impact of these plots was assessed using an anonymous survey. Total of 89 students participated and 78 of them state they have used the plots to determine their ranking. Total of 36 students (47% of 78) report increased efforts; for students ranking in the bottom 1/3 of the class this percentage was close to 60%. The disadvantage of using rank-performance plots as a motivation tool is an increased anxiety.

Introduction

Having high cognitive abilities does not guarantee success in college. Approximately one student in every five students with GPA of A/A+, and SAT of 1300+ will fail to complete college in six years¹. Similar statistics can be found elsewhere² and have been attributed to poor non-cognitive skills. As depicted in Figure 1, Conley³ identifies four major categories of skills that a person must possess to be successful in college. The academic behaviors and the contextual skills are called “non-cognitive” because these attributes cannot be measured using IQ tests and standard academic tests. To better understand the academic performance of students, assessment of non-cognitive attributes is needed. Unfortunately, such assessment is not a simple task; there are many non-cognitive attributes and their interactions are complex⁴.

This paper is concerned mostly with motivation and self-discipline and their correlation to certain academic behaviors and academic performance. Similarly to other “non-cognitive” factors, internal motivation and self-discipline are difficult to measure. Ideally, the assessment should be direct and the tools we use should not change the behavior of our subjects. Two such assessment tools are discussed in this paper.

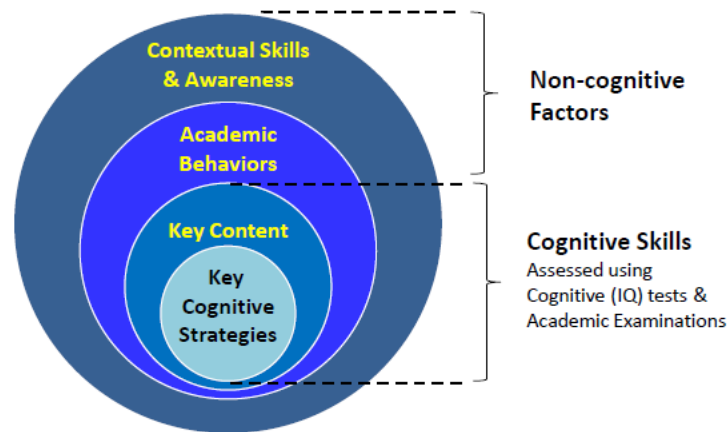

Figure 1: Facets of College Readiness (after Conley³)

Course Description

The study was implemented in a 10-week introductory Semiconductor Device Electronics Class (EE 306). This course is mandatory for all students pursuing a bachelor degree in electrical engineering and computer engineering at Cal Poly, SLO. In the curriculum of these two programs, EE306 is typically taken in the Fall quarter of the junior year.

The course is structured with three fifty-minute lectures each week. The total enrollment is usually 150-160 students. Four to five individual sections of are offered, with individual enrollments of 30-40 students. Two and often three different instructors teach the individual sections. Reported here results are for three (out of five) sections. These three sections were taught by the same instructor and had combined enrollment of 114 students. Students were expected to attend all face-to-face lecture classes, but no attendance was taken or enforced. All in-class lectures were video captured⁵. Access to the recorded videos was provided using PolyLearn. PolyLearn is a Moodle-based Learning Management System used at CalPoly, SLO.

The course grading was based upon each student's performance on one midterm, three quizzes and a comprehensive final exam.

Use of Optional Resources and Academic Performance

Improved understanding of students learning habits can be obtained by monitoring the use of important but optional resources⁵. After each lecture, a homework assignment was up-loaded to PolyLearn. The homework was optional and solutions were not collected for grading. The cumulative number of times students accessed the assignments folder was used as indicator of motivation and study habits. The expectation was that motivated students will regularly check the assignments folder. Therefore, high level of access to the assignments folder would suggest good study skills. Conversely, low level of access would generally imply poor study skills; low total access results when a person downloads many assignments at once (when "cramming" for an exam, for example).

The 6-week cumulative access of each student was rank-ordered. The same was done for the exam performance and quiz performance. Table 1, Table 2 and Table 3 show the pair results. As seen in Table 1 and Table 2, the student population is classified into nine different categories depending upon their level of access to homework materials and class performance. Should performance and access were perfectly correlated, the entries on the main diagonal would have been 38 each (1/3 of the class enrollment) with all the other entries being zero. This is not the case – which was expected. It is notable however that the entries on the main diagonal have the largest value, suggesting some degree of positive correlation between “access counts” and academic performance. More importantly, the lower diagonal entry of Table 3 correctly identifies the two students who will eventually fail the course as well as two of the three students who will receive D+ as a final grade. The other three students will eventually receive below-average course grades of C, C+ and C- . It is notable, that these at-risk individuals were identified prior to administering the last quiz and the final exam.

Table 3 also indentifies four students with unusual access-performance characteristics. The two individuals with heavy access but poor (initial) performance would eventually “recover” and achieve course grades of C and B. The course grades of the other two students were B+ and A- . The class average was B-.

Table 1

		Class Rank based upon Mid Term Exam		
		Top 1/3	Mid 1/3	Bottom 1/3
Rank: Access to HW Assignments	Top 1/3	20	9	9
	Mid 1/3	9	17	12
	Bottom 1/3	9	12	17

Table 2

		Class Rank based upon Quizzes		
		Top 1/3	Mid 1/3	Bottom 1/3
Rank: Access to HW Assignments	Top 1/3	21	10	7
	Mid 1/3	12	14	13
	Bottom 1/3	5	14	18

Table 3

		Class Rank based upon Mid Term & Quizzes	
		Top 1/3	Bottom 1/3
Rank: Access to HW Assignments	Top 1/3	14	2
	Bottom 1/3	2	7

The above-described approach was reasonably successful in identifying students at risk of failing the class. However, I would not recommend this strategy, because it weakens the attainment of the learning objectives. An alternative approach for determining the internal motivation of students and some motivation-related academic behaviors is described next.

Performance Awareness and Academic Performance

I intentionally did not post grades. Hence, to keep track of performance the students had to collect their graded work. Under these conditions, I argue, uncollected work is indicative of deficiencies in motivation, poor class attendance and poor attendance of office hours. I also allowed students to collect the graded work of their friends, so uncollected work might also imply inadequate social interaction with fellow students.

Total of 29 students, approximately 25% of the class, have failed to collect at least one major graded work – quiz or a mid-term paper. Not surprisingly, most of those students had relatively poor performance. Twenty-one of them had below-average class ranking and all five students with final grades of F and D+ were part of the underperforming group of 21 students.

The Impact of “Forced” Performance Awareness

It is my impression that students with poor academic performance also have a poor understanding of their class standing. This issue, I argue, can be resolved by use of rank-performance plots. These are plots where raw performance is rank-ordered. One such plot is shown in Figure 2. Using this plot a student (who knows his mid-term score) could determine his class ranking.

For a large class and a well-designed exam, the rank-performance plot will have three regions – two steep ones at the beginning and the end and a shallow region in the middle. Scores falling within the steep regions indicate “outlier” performance – either exceptionally good or exceptionally poor performance.

A rank-performance plot can also be used as a motivation tool. This is especially true when the professor grades on a curve. According to the achievement goal theory, the use of rank-performance plots falls into the “performance goals” category^{6,7}.

The rank-performance plots were provided in week #7 and the impact was assessed in week #10. An anonymous survey was used for the assessment. The survey was administered on the last day of classes. Only those students present on that day took part of the survey; total of 89 students (78% of 114 students) participated. The survey questions are listed on the next page.

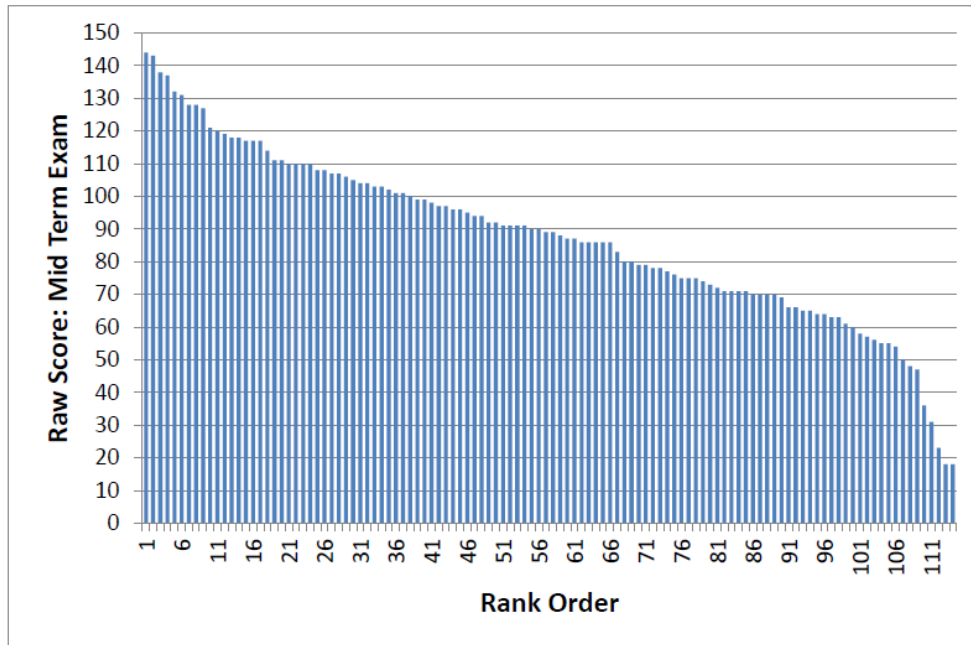

Figure 2: The plot shows exam scores ordered by rank. Each bar corresponds to the performance of a unique student in a class with enrollment of 114 students.

Please, share your opinion on Rank-Performance Plots

Q1: Do you like knowing your (relative) class standing?
 YES NO If "no", skip questions 2,3 & 4.

Q2: Did you use the provided Rank-Performance plots to determine your class standing?
 YES NO If "no", skip questions 3 and 4.

Q3: What is your current class ranking? (Please, be honest!)
 Top 1/3 Bottom 1/3 Mid 1/3

Q4: What was the Impact of the provided Rank-Performance Plots on you? (Check all that apply)
 No impact Made me anxious
 Increased my confidence Decreased my confidence
 Made me work harder Made me work less

Write your own:

Q5: Why not?

It is notable, that 82 students answered positively to Question #1 and 78 of them (88% of all responding students) used the plots to determine their class ranking. The impact of the provided plots upon the study efforts of students is summarized in Table 4. As seen, total of 37 students (approx. 47%) report increased efforts while only 7 (approx. 9%) report decrease in effort. It is notable that the "bottom 1/3" category is under-represented in the survey. This would suggest that (on average) more under-performing students were not present in class or answered

negatively to Question #1. The psychological impact of using rank-performance plots is summarized in Table 5. It is interesting, that nearly all students who report increased efforts also report change in their confidence level and/or increased anxiety. Unfortunately, a significant number of students, having middle and low ranking, report heightened anxiety without the sought-after benefit of increased effort. While rank-performance plots are seen as a power motivation tool, I would only use them in the second half of the course.

Table 4

Rank (self-reported)	# of Students	Efforts	
		Increased	Decreased
Top 1/3	31	13 (42%)	6
Mid 1/3	32	15 (47%)	1
Bottom 1/3	15	9 (60%)	0

Table 5

Rank (self-reported)	# of Students	Confidence		Increased Anxiety
		Increased	Decreased	
Top 1/3	31	23	1	6 (19.3%)
Mid 1/3	32	7	6	21 (65.6%)
Bottom 1/3	15	1	7	12 (80%)

Bibliography

1. DeAngelo, L., Franke, R., Hurtado, S., Pryor, J.H., and Tran, S. (2011). *Completing College: Assessing Graduation Rates at Four-Year Institutions*, Los Angeles: Higher Education Research Institute, UCLA
2. Kyllonen, P. C. (2012), *The Importance of Higher Education and the Role of Noncognitive Attributes in College Success*, *PEL* 2012, 49(2), 84-100.
3. Conley, D. T. (2007). *Redefining College Readiness*, Eugene, OR: Educational Policy Improvement Center.
4. Farrington, C.A., Roderick, M., Allensworth, E., Nagaoka, J., Keyes, T.S., Johnson, D.W., & Beechum, N.O. (2012). *Teaching adolescents to become learners. The role of noncognitive factors in shaping school performance: A critical literature review*. Chicago: University of Chicago Consortium on Chicago School Research.
5. Prodanov, V. I. (2012) *In-Class Lecture Recording: What Lecture Capture has to Offer to the Instructor*, Proc. ASEE PSW Section Conference, San Luis Obispo, April 19-21, 2012.
6. Elliot A., McGregor, H. & Gable, S., (1999) *Achievement Goals, Study Strategies, and Exam Performance: A Mediational Analysis*, *Journal of Educational Psychology* 1999, Vol. 9, No. 3, 649-563.
7. Eccles, J.S. and Wigfield, A. (2002), *Motivational Beliefs, Values, and Goals*, *Annual Reviews Psychology*, 2002, 53: 109-32.

Increasing Lab Participation and Content Retention Through Supportive Laboratory Preparatory Assignments

**Tina Smilkstein,
California State University at San Luis Obispo**

I. Abstract

A study is done on an electrical engineering circuit lab course to assess the effect on participation, retention of course content and student satisfaction when prelab assignments were expanded to include a write up of the experiment background and goals. Reading that was created specifically for each lab covered background for the lab that the students should be bringing with them from previous courses but did not tell them how to do the lab. They were asked to summarize the reading on the background by the night before the lab in one or two paragraphs. The inspiration for the addition of this assignment was the observation that students that had trouble with previous quarter's subjects were falling behind even further behind and showed low participation, confidence and success. Retention was assessed using test and report scores as well as observations of students in later classes. Participation was assessed through observation and survey results. Satisfaction was assessed through survey results. Survey results showed that 1/3 of the weaker students increased their participation over other labs in the sections that had prelab statements whereas the section with no statements had zero students saying they participated more. Twice as many of the weaker students felt more prepared for lab than the lab without prelab statements. There was also a general upward trend in report grades and quality of organizational and reasoning sections of reports. Through observation, it appeared as if the weaker students were more confident and participating more also.

II. Introduction

Cal Poly implements its "learn by doing" tenet by pairing most lecture classes with a laboratory. The majority of labs require a prelab to help prepare the students for the lab and a postlab to require the students spend time analyzing what they observed in lab. The three pronged process of preparing for the lab, experiencing the lab and then thinking about what has happened in the lab forces the students to look at the material multiple times and follows well the adage "*Repetitio mater studiorum est*" (Repetition is the mother of all learning). But is this really how a lab course should be structured? Because the course is a lab course, shouldn't the assignments be all about making their time in the lab the most valuable? Ideally, the three pronged flow requires the student to analyze the events they observed in lab in the postlab in order to deepen their understanding of a behavior. But shouldn't the stress be on making them curious enough and well equipped enough to realize that something is going on during lab and have them investigate it there? The first inspiration for this work came from students often not having the tools to realize, in lab, that a curious behavior is occurring and to be able to investigate it right then and there.

The second inspiration for this work was the observation that the students that did not do well in previous classes or that have trouble with circuit courses in general were not participating, not

contributing to their groups, not doing well on exams and reports and falling even farther behind compared to their classmates by the end of the class. As happens in many group projects, the most informed, highest-achieving and/or strongest personality often ends up doing the majority of the work and the other members of the group follow orders or stand mute. Observing groups and the individuals in them that seemed to be non- or low-participants, there seemed to be a common thread of a lack of confidence in their abilities and their knowledge. Observations of low-confidence students making good suggestions to their lab partners and being ignored is not a rare event.

The third inspiration for this work was the fact that information on weaknesses of the students was not clear until during the actual lab itself or after the lab had been finished. Feedback is good but the late timing of identification of problems seemed such that it wasn't giving the student maximum value.

The course where these observations took place is the third in a four-quarter series of electronics classes. The first quarter of the sequence starts out holding hands with relatively cook-book style labs. Each successive course gives the student less and less information on the lab procedure until, in the fourth course, the lab is describe in one or two sentences and the student is required to make almost all design decisions. The course targeted here, being the third course in this series, requires a large amount of student decision making in the lab. This prepares them for the fourth quarter in the series and life as an engineer. Any addition to the course to help the students that are missing material from previous quarters must preserve the goal of the labs to make them problem solve.

With these inspirations in mind and the requirement of preserving the problem solving content of the labs, the addition of a "prelab statement" was added to the prelab work. The prelab statement required the student to read a 6 to 15 page handout and summarize the important points in one or two paragraphs. The majority of the content of the reading is background for the lab but does not give answer to how to do the lab. The readings provide the students that need review the chance to start the lab on equal footing with the students in the lab that have better retention of material from previous quarters. It also is a way to sneak in a reminder of topics discussed in previous classes that they may have forgotten if they have not used them since the course. The statements were due the night before the lab which gave time for the instructor to grade and return the statements, with feedback, before lab. To keep the complete work for the course from overwhelming the student, the postlabs were reduced. Two major reports and one rewrite were due during the quarter and on the weeks where a report is due the prelab reading was reduced. In this way, either an involved prelab or postlab (report) was due each week but never both.

Data used in this paper include report content and thinking level grades, the lab final exams, and a survey given to students to see how they think prelab statements enhanced or detracted from the course. Observational results are also included on retention and participation.

III. Example Prelab reading

The first week's lab for the course being discussed here requires understanding of the two previous quarter's material on how a BJT transistor works. The important equations are given

and a more qualitative rather than quantitative explanation of the behaviors that need to be understood for the lab are given. Higher level explanations for behaviors are given so that the student can recognize behaviors in lab without having to do math. Care is given to connect those qualitative explanations to the equations and/or math before finishing the reading.

The reading is purely background. The first lab gives the student two circuits and asks them to say if they can be used to find particular values such as β or the early voltage. The actual prelab (not prelab statement) is a question on whether they can find those values using two given circuits and, if they can, how they would do the characterization (find the values for β , the early voltage and turn on voltage): How they would connect up the machines, what data they would gather and how they would use the data to find the values. Once in lab, the first assignment is to discuss with their lab partner their techniques using the two circuits and if they want to use one of those circuits or another to characterize the transistors they will use for the rest of the quarter. In this case, the lab reminded them of how BJT transistors operated and what some of the important characteristics were that they would need to investigate.

IV. Additional Changes to Course structure

In addition to the prelab statements, the report format and frequency was changed. Report quantity was reduced but each report was more in depth and must follow a format nearer to that of a technical journal paper. This course targeted in this study was suited to such a report format in that all labs are building towards a enabling the student to build a single large circuit at the end of the quarter so three or four labs can be bunched together to form a story. The final report is on the final complete circuit which means that ten weeks of lab information are included in the report. The survey results include a perception that the format used in this study is more work than the usual format but it can be argued that the final report has left the students with that perception.

Another addition to the lab are “checkoff questions”. Checkoff questions are question that the instructor has the student answer verbally, face to face, during lab. These may also be affecting survey and test score results also.

V. Results: Observational

Observationally, prelab statements were a success. In the most recent quarter, five students were noted as less confident early in the quarter due to grade issues or knowing them from previous quarters as low-participants. These five students completed all prelab statement assignments. They were observed throughout the quarter actively participating in their group in doing calculations, using the equipment and talking with their groupmates. The second most recent quarter four students were noted as less confident. One of the four students turned in all of their prelab statements and did well in the class again participating in the group at the level that was near equal with the rest of the group members. The three other students did not turn in their prelab statements for approximately half of the labs and did not participate at a level equal to their groupmates. They were also not able to discuss the lab as well as their peers and consistently had lower grades on reports and exams.

Another rewarding observation was that students seemed to be able to ask better questions in lab and were doing investigation and analysis of their circuits in lab rather than just for the postlab report.

VI. Survey on Student Perception

A survey was created and sent to 225 students. 74 students responded by the time this initial paper was submitted. The majority of students that answered were in labs where prelab statements were used due to many in the earlier classes already having graduated. 18 students were in labs which didn't have prelab statements. In the first survey sent out, instructions were given to the students that did not have prelab statements to do as follows: "If you didn't have prelab statements when you took EE348, still try to answer the questions but replace prelab statement with just prelab. Make sure to note in the comment section that you didn't have prelab statements." The second survey that was sent out went to students known to not have taken the course when prelab statements were used and the questions had prelab statement removed and prelab put in its place.

Survey:

1. Background: What quarter did you take EE348 and what grade did you get?

2. What I think of circuits classes:

- I do well in circuits courses and they are my favorite.
- I do well in circuits courses but they aren't my favorite.
- I don't do well in circuits courses but they are my favorite.
- I don't do well in circuits courses and they aren't my favorite.

3. With the addition of the prelab statements: The work load seemed less/more/the same as other labs.

- Less work than other labs at Cal Poly.
- Same amount of work as other labs at Cal Poly.
- More work than other labs at Cal Poly.

4. With the addition of the prelab statement and reading, when you came to lab, did you feel:

- Less prepared than other labs at Cal Poly.
- Just as prepared as other labs at Cal Poly.
- More prepared than other labs at Cal Poly.

5. With the addition of the prelab statement and reading, when you came to lab, did you feel:

- As if you participated in the lab less than other labs at Cal Poly.
- As if you participated in the lab the same amount compared to other labs at Cal Poly.
- As if you participated in the lab more than other labs at Cal Poly.

6. With the addition of the prelab statement and reading, when you came to lab, did you feel:

- Like you learned less in lab than in other labs at Cal Poly.
- Like you learned the same amount in lab compared in other labs at Cal Poly.
- Like you learned more in lab than in other labs at Cal Poly.

7. With the addition of the prelab statement and reading, when you came to lab, did you feel:

- As if you retained information from the lab less than other labs at Cal Poly.
- As if you retained information from the lab the same amount compared to other labs at Cal Poly.
- As if you retained information from the lab more than other labs at Cal Poly.

8. With the addition of the prelab statement and reading, when you came to lab, did you:

- Like the lab format less than other labs at Cal Poly.
- Like the lab format the same amount compared to other labs at Cal Poly.
- Like the lab format the lab more than other labs at Cal Poly.

9. General comments: Do you have general comments on the format of the labs in terms of prelab, postlab or during lab work? (Or anything else). I'm especially interested in people that have struggled with previous labs and whether this helped or not. Is there some affect of the format that I am not realizing?

VII. Results: Student Perception Analysis

The first results evaluated were by dividing the data into with prelab statement and without prelab statement. This is shown in Figure 1.

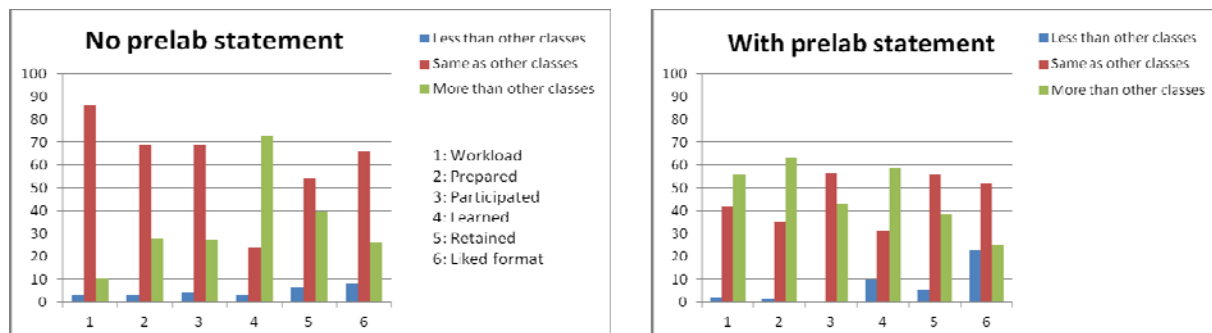

Figure 1: Survey results for students that used prelab statements and those that didn't.

The columns represent questions 3 through 8 on the survey. Column 1 is the perceived workload by the student. As previously mentioned, care was taken to try to keep workload constant from

week to week except on report weeks. It is speculated that the noticeably higher perceived workload is due to the final report.

Column 2 shows a clear difference in the perceived preparedness with and without prelab statements. With no prelab statements twice as many students thought that they were just as prepared for lab as the were in previous lab courses whereas, for the students that did prelab statements, the twice the number of students perceived that they were more prepared than in other labs.

Column 3 represents how the students perceived how much they participated in the labs. Almost 50% of the students that did prelab statements said that they thought they participated more in lab than they did in previous labs verses about 25% for the students that didn't do prelab statements. This is a key result for this research.

Column 4 is good news because it says that the majority of students in this course learned more in this lab than they did in previous labs.

Perception of retentionof material, shown in column 5, didn't change between the two teaching styles and showed a little less than 50% of the students in both groups retaining more from this class than previous lab classes.

Column 6 shows that the same number of students disliked the new format as liked it more. This also could be affected by the report writing.

The author admits to getting joy from seeing less successful students succeed and also admits to having that as an ulterior motive for pursuing this research. Having all students succeed is, of course, the goal, but seeing students that may have not realized that they can succeed, succeed is an event that is worth celebrating. Obligatory laboratory preparation has been shown to benefit students who are willing to work but poorly organized or those who may skip preparation due to their course load^[1] and, because of the clear advantages, preparatory work done for most labs. To see if the change in the prelab routine of adding a prelab statement helps the students that may have struggled in their previous labs, the survey asked the student to self identify their strengths and likes:

Title on graphs	Meaning
L&G	L ikes circuits & gets G ood grades in circuits class
D&G	D islikes circuits & gets G ood grades in circuits class
L&B	L ikes circuits & gets B ad grades in circuits class
D&B	D islikes circuits & gets B ad grades in circuits class

Figure 2 shows the results for students that didn't do prelab statements and Figure 3 shows the results for the students that did prelab statements. The X-axis is the same "Less" ("Less than other labs taken at Cal Poly"), "="("Same as other labs taken at Cal Poly") and "More" ("More than other labs taken at Cal Poly"). Values have been normalized to sum to 40.

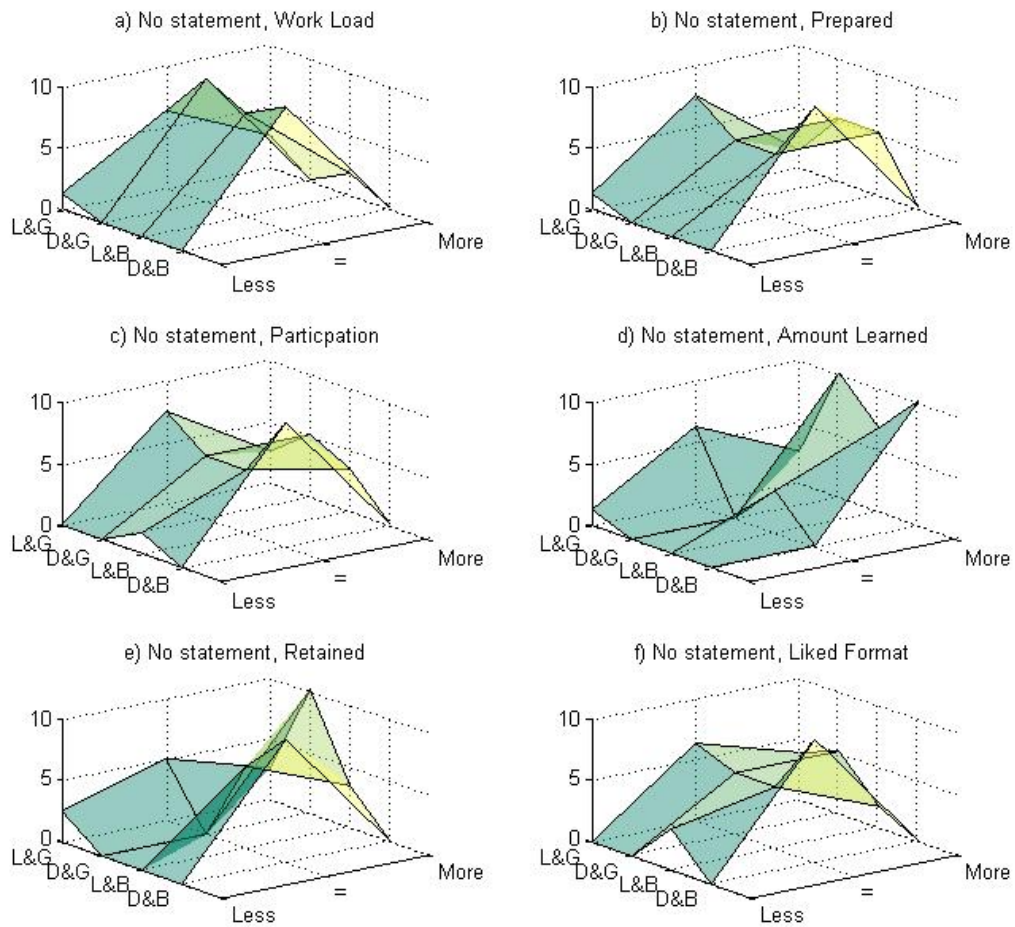

Figure 2: Survey results for students that didn't do prelab statements. Four divisions: L&G (Likes circuits/Good grades), D&G (Dislikes circuits/Good grades), L&B (Likes circuits/Bad grades), D&B (Dislikes circuits/Bad grades).

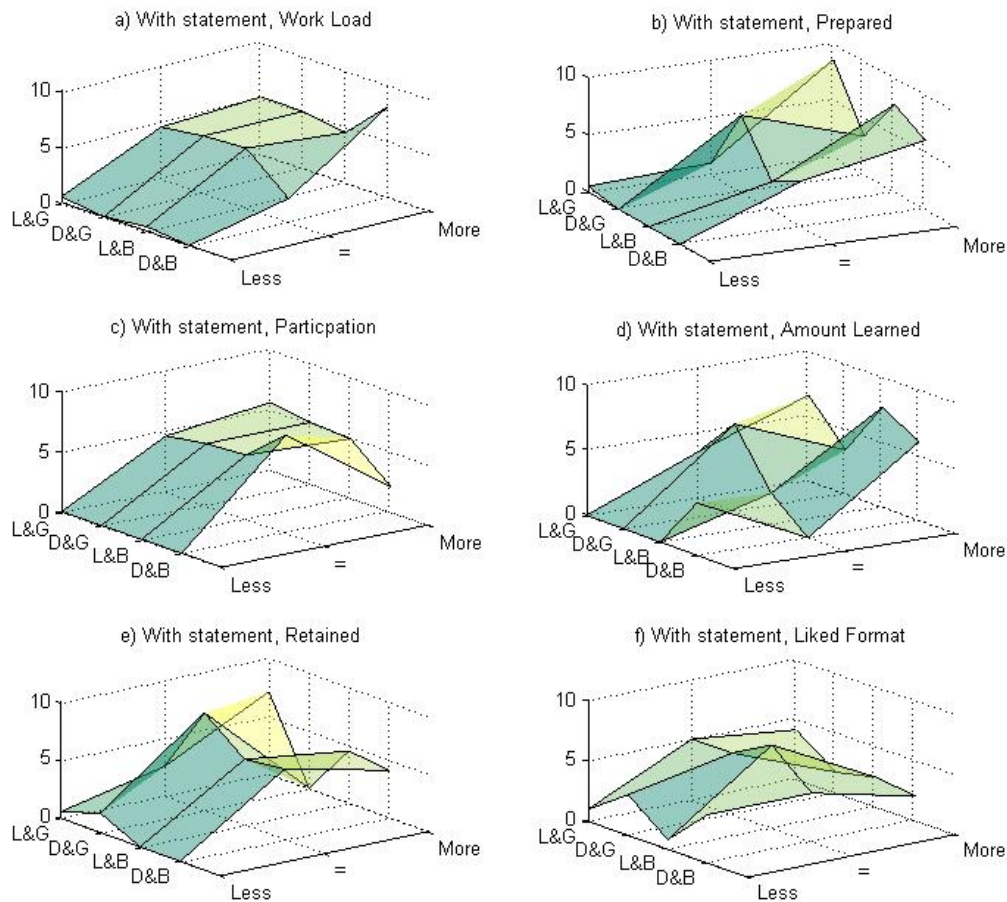

Figure 3: Survey questions for students that did prelab statements. Four divisions: L&G (Likes circuits/Good grades), D&G (Dislikes circuits/Good grades), L&B (Likes circuits/Bad grades), D&B (Dislikes circuits/Bad grades).

In graph a) on Figure 2 shows that for all students, whether they are good at circuits and/or get good grades, the amount of work was perceived to be the same as previous other labs whereas, as shown in graph a) of figure 3, you can see that the weaker students perceived the class as more work than the students that are good at circuits.

Graph b) in Figure 2 shows that the weaker students feel as prepared as previous labs but, with prelab statements, (Graph b) in Figure 3) shows that twice as many of the weaker students felt more prepared than in previous quarters. This is an important result.

Also note that graphs c) in Figures 2 and 3 show that none of the weaker students felt as if they participated more than they did in previous classes in the sections without prelab statements whereas about 1/3 felt like they participated more in the sections with prelab statements.

As in the summary graphs in Figure 1, both groups felt as if they learned a lot in this class as compared to other labs but the data on whether they felt as if they retained information was very

different. None of the weaker students felt as if they retained more than other labs in the section without prelab statements but about 50% of the weaker students said they felt as if they retained more in the sections with statements.

VIII. Results: Comparison of Report and Exam grades

The comparison of report grades is challenging due to the subjective nature of the grading. Also, in quarters where the level of the reports were low, grades may be inflated due to bad reports looking better compared to their competition. Figure 4 shows all report grades from Spring 2010 to F2012 normalized to 1.2. The dotted line shows where prelab statements were introduced. This doesn't prove cause and effect but the main change in how the course was taught was the introduction of prelab statements. Grades have stayed steady above the levels that they sat at before introduction of prelab statements. Reports were not included in a graph if that particular question wasn't used in grading that quarter.

Figure 5 shows the report score that describes whether the student can logically explain their circuit design and results. It too seemed to improve around the time that prelab statements were introduced.

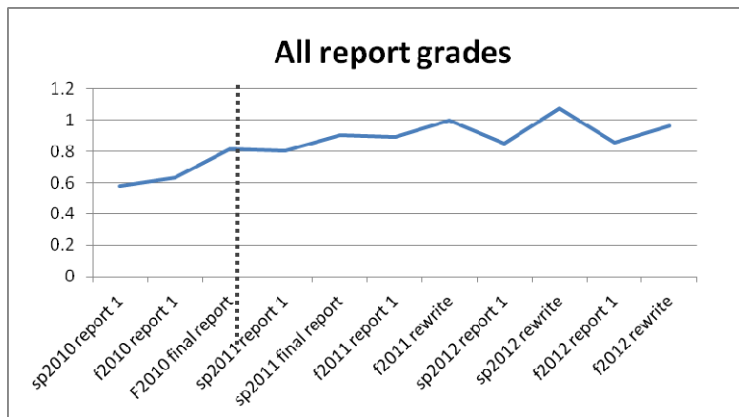

Figure 4: All reports grades compared. Dotted line is where prelab statements were introduced.

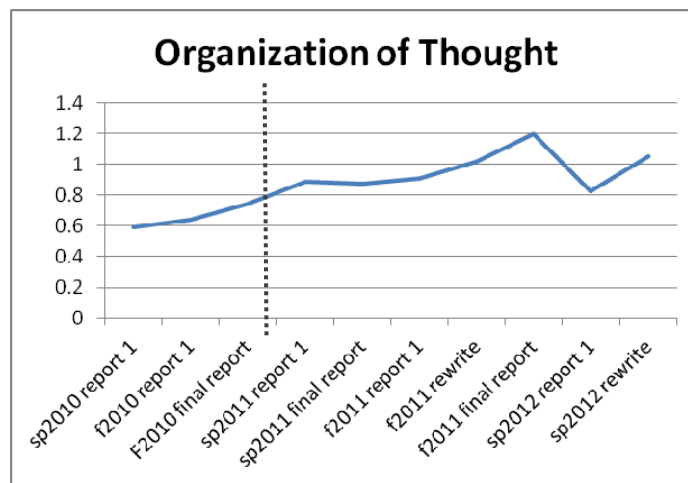

Figure 5: Organization of thought. The ability to tell the "story" of the design of their circuit.

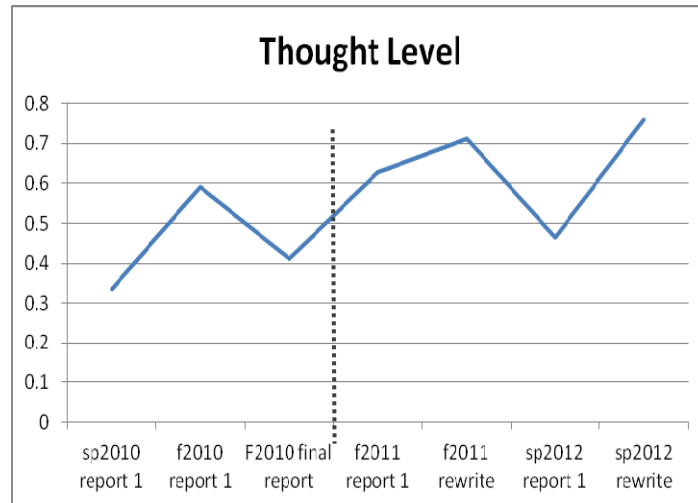

Figure 6: Thought level. This is a measure of the student's attempts to explain unexplained behaviors.

Figure 6 is a measure of the student's explanation of behaviors that didn't fit theory. Scores are high if the student uses their technical knowledge to explain a behavior and low if the student explains a behavior off as human error or machine error. Spring 2012 was a weak quarter for reports.

IX. Student Comments

Both negative and positive comments are included here. The majority of negative comments were in regard to the work load. Positive comments often mentioned being forced to really understand the lab before getting to the lab.

Example positive comments:

- “Prelab questions that explore the theory behind the lab is useful. Also pointing out common mistakes before starting the lab saves alot of time”.
- “The prelab statements helped me get a better sense of the overall purpose of the lab. The notes i took in order to make my prelab statement helped me outline the main ideas of lab”.
- “It is a really good way to learn more before working on it. The need to submit a prelab statement makes you read the prelab reading carefully and more than once so that you get to understand the content. I felt it helps a lot for grasping the ideas beneath the lab experiment of that week. In addition, in the end of the semester it helped a lot to have this little summaries when writing the final reports and also as an index for knowing which lab reading I had to study again for a given subject. In the labs, one of the things I liked most were the checkoff questions, those helped me understand somethings I didn't have clear or reassure the learned things. Another thing I liked were the comments at the beginning of the labs, or the ones on the amplifier designs in the last labs, they were clarifying most of the times for some doubts I used to have”.
- “I really liked the pre-lab reading because it prepared me to answer the questions during lab. It was really descriptive and interesting because it showed the concepts clearly and how it should be used in applications. I liked how you gave everyone a chance to answer since there is sometimes an imbalance of work during lab. Thus, it gives each lab partner a reflection of how they're doing in lab in general and how much they should be contributing to the lab”.

- “Great idea because more people try to keep up with the actual lab work instead of leaving it to lab partners to have the understanding”.
- “I really like the pre lab write up. It really helps me come into the lab more prepared. Even though I hate the extra work. They really do pay off because you know exactly what the goal of the lab is”.
- “I thought the prelab statements were a WONDERFUL idea along with the final lab reports. Normally, prelab readings are in a manual and they don't make much sense so sometimes I skip reading them. I think you're English-ed versions of the labs made much more sense. Then, making us write a little summary about it made me understand it more. I didn't want to skim the prelab reading, I actually wanted to understand everything so I could put it in my own words. The prelab statements were especially helpful when writing the final reports. They made me realize why I was getting some bugs and what I was doing wrong. ...”

Example negative comments:

- “The reading was unclear. Try to make it much more concise and less wordy. Prelab statements don't help students understand the material. Clear explanation of the subject matter is most important”.
- “Just felt like there was too much work assigned along with the lecture section which lowered the retention of the information. But it could just be the amount of material the class required”.
- “It did help with the individual labs, it is a lot of information and work for a one unit class though”.
- “the only thing I really have to say is in regards with the pre-lab statements and the pre-lab. Doing the pre-lab statements helps a lot but in addition to the pre-lab problems, it could sometimes be a lot of work especially when a student has about three labs in one quarter”.

X. Conclusions and Further Work

The results of introducing a prelab statement to a Cal Poly circuits lab course were gathered and analyzed. Report grades improved from the quarter that prelab statements were introduced. Two particular sections of reports were analyzed: Organization of thought (ability to logically tell the story of their circuit design and testing) and thought level (ability to explain behaviors that differ from theoretical behaviors using technical arguments). Both showed a general trend upwards after the introduction of prelab statements with the exception of one quarter where report grades were consistently lower.

Student perception of what prelab statements did for them was telling. 1/3 of the weaker students increased their participation over other labs in the sections that had prelab statements whereas the section with no statements had zero students saying they participated more. Twice as many of the weaker students felt more prepared for lab than the lab without prelab statements.

Observational results include increased confidence and participation from the weaker students and more discussion and analysis going on in lab as compared to sections that didn't do prelab statements.

Though [2] concludes that gender equality across a group makes for better decision making by the group, their premise and arguments can be extended to equality in general. The results shown here suggest that the students that perceived themselves as weaker gained confidence and contributed more to their group. This suggests that the group members will now be more equitable, and, as a result, will make better decisions. Better decisions by the group mean that the improvement of the weaker students' skills also benefit the stronger students' decision making skills and experience too. Lab groups are ideally 2-person groups but 3-person groups have been necessary recently due to economic issues. Three person groups, in theory, expose each student to more opinions and therefore a more varied learning experience if all members participate but they also present the danger of having two of the three students take over and leave the weakest student behind. If the weakest student is empowered and is able to discuss their opinions and reach convergence^[3], the process becomes more complicated but more successful and valuable.

Because this course is part of a series that requires students to develop their decision making skills quarter by quarter, one of its jobs must be to increase the independence of students where possible. In many labs, data is collected and the student is at home when they have to do analysis. In general that means that they have no way to investigate odd behaviors or delve further into something that interests them. Giving the student the information so that they have the ability to investigate on their own during lab should be an important consideration when teaching a course like this. The labs used in this class give the students the opportunity to carry out inquiry based learning to solve the central problem^[4] but, at the same time, they are given the opportunity to go further. The reports are mentioned early on in the class and the students are told that they often won't know exactly what data they will need until they start to write up the report and try to support their claims. They are also told that it's their responsibility to gather the data for the report. This gets them talking about what data might be important and gets them to further gather data and experiment.

Future work will include understanding why the workload was perceived as so high as compared to traditional sections of the lab and to better measure the advantages and/or costs of prelab statements.

Bibliography

- [1] M. Rollnick, S. Zwane, and M. Staskun, "Improving pre-laboratory preparation of first year university chemistry students," *International Journal of Science Education*; Vol. 23 Issue 10, p1053-1071, 19p, October 2001
- [2] C. Kirchmeyer, "Gender roles and decision-making in demographically diverse groups: a case for reviving androgyny," *Sex Roles*, Vol. 34, p649-663, 15p, May 1996
- [3] R. Goldstone, T. Wisdom, M. Roberts, and S. Frey, "Learning Along With Others," *Psychology of Learning & Motivation*; Issue 58, p1-45, 45p, 2013
- [4] G. Corder, and J. Slykbuis, "Shifting to an Inquiry-Based Experience," *Science and Children*; Vol. 48 Issue 9, p60-63, 4p, May 2011

Protection Considerations for Telecommunications Network

**Dr. Ibraheem A. Kateeb, Khaled F. AlOtaibi, Dr. Larry Burton, Michael S. Peluso,
Dr. Evelyn R. Sowell**

North Carolina A&T State University, Greensboro, NC, USA

kateeb@ncat.edu, khaled_u2@hotmail.com, lwburton@ncat.edu, peluso72@gmail.com,
es992760@ncat.edu,

Abstract

For the majority of the last century, single service fixed-line based networks were the primary means of communications. Over the past few decades, we have seen tremendous change to the traditional fixed-line model including the introduction of wireless networks and a shift in focus from single-service to multi-service networks. These newer multi-service networks are designed to provide broadband via both fixed-line and wireless connections. All of this rapid change has resulted in very complex network management organizations and safety issues that are distinct to each network type. This paper will provide a survey and discussion of the safety issues that relate to both fixed-line and wireless networks. It will examine how the infrastructure service model is drastically different between traditional fixed-line service providers and wireless service providers. It will explore issues and regulations relating to buried telecommunications plant. Finally, it will also review safety issues that relate to optical cable and fiber optic networks.

Keywords- Telecommunications, Safety, Confined Spaces, Turf holders, Fiber Optics, Fatalities, Cellular Towers, Utility Poles.

I. Overview: Different Service Models for Different Networks

Telecommunication cables including fiber, coax, and twisted pair are used in both hard line and wireless applications. In traditional hard line systems, the transport cable maintains a connection from the head end of the network all the way through the end user premise. This is true no matter what form of cable is being used. In a wireless system, the hard line cables are used for backbone transport of data and cell towers are erected to provide last mile connections. The two architectural structures require fundamentally different approaches to construction and maintenance, which results in a fundamental difference in how safety issues are managed.

There is a tremendous difference in how wireless communications companies manage their service and installation work force. As the wire line industry is over a hundred years old, it is managed with a more traditional model of service workers who are directly employed by their respective companies. The workers tend to be organized into powerful unions, figure 1.

The wireless industry is dominated by a complex array of sub-contractors. This is due to multiple factors including relative newness of the wireless industry as well as the need for a flexible work force to be highly reactive to large build outs, figure 2. In wire line applications there are different issues that affect metallic conductors such as twisted pair versus optical cables. There are also different issues that arise from working with aerial applications of cables versus those of

buried applications. Section II gives information about Fixed-lines safety issues. Section III discusses Wireless Safety issues. In Section IV, we discuss Optical Safety Issues.

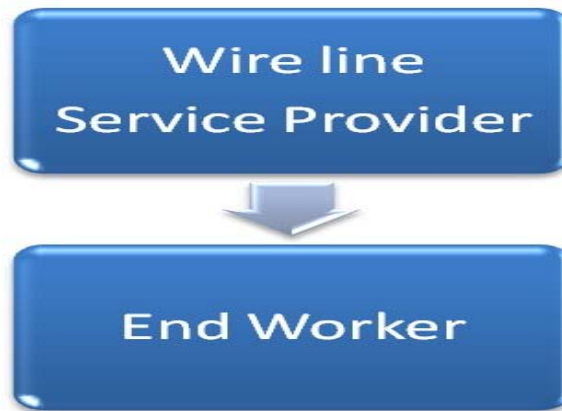

Figure 1. The wire line industry



Figure 2. The wireless industry

II. Fixed-Lines Safety Issues

Utility poles were first used by Samuel Morse when he discovered that faulty insulation led to a failure in his telegraph. Modern utility poles can be made of wood, metal, concrete, or composites like fiberglass and recycled plastics. In all cases utility poles are designed to keep communications and electrical conductors elevated from the ground to avoid issues such as grounding, pedestrians, plants, animals, and malicious acts. Joint use poles are usually owned by one utility, which leases space on it for other cables. In the United States, the National Electrical

Code, published by the Institute of Electrical and Electronics Engineers (IEEE), sets the standards for construction and maintenance of utility poles and their equipment.

The joint use of utility poles by various service providers has a long history. This activity was much less complicated however, when the majority of end users were services by regulated utilities. In most cases this meant one “power” company and one “telephone” company. Before the age of cable television, those that had televisions used broadcast signals transmitted over the air. Over time, regulatory and market changes including the extensive deployment of cable television systems, the development of a competitive telecommunications market, the widespread provision of broadband communications services, and today the move toward citywide wireless networks have all resulted in increased demand for pole space. Each of these technical and commercial developments has had implications on pole attachments, in many cases prompting legislation, regulation, and adjudication ¹.

This complexity has created safety issues for Aerial applications. The focus of this study will be on telecommunications related accidents and fatalities, but by necessity the majority of the information available via sources such as OSHA reports pool information into the generic category of “utilities”.

There are two primary areas that are the cause of Aerial plant injury and fatalities. Specifically the areas are falls and electrical shock. The higher percentage of fatalities in wire line applications is due to high voltage electrical shock. Although the voltage on metallic communication cables is not fatal, the close proximity of electrical lines means that there is a high probability of interaction between the workers, their equipment, and the high power lines. An example can be seen in recent case of Verizon technician Douglas Latham who was fatally electrocuted while working on a joint use utility pole in September 2011. Verizon was cited with over \$140,700 in fines for repeated failures to abide by critical safety rules. Specific violations included not providing grounding equipment, failure to provide high voltage gloves and helmets, lack of safety inspections and safety training ².

For buried plant applications, the majority of danger relates to the dangers of working in confined spaces. These confined space hazards can range from an oxygen deficient atmosphere or exposure to toxic agents. Examples of toxic agents include plugging compounds and solvents. There is also the possibility of an explosion when working in proximity to natural gas lines. Finally there are environmental hazards that cannot be changed due to the structural nature of the confined space.

Confined spaces are areas that, by design, have limited openings for entry and exit, unfavorable natural ventilation that could contain or produce dangerous air contaminants, and are not intended for continuous worker occupancy. The formal definition of a confined space by Occupational Safety & Health Administration(OSHA) is found in the OSHA Regulations document titled Standards – 29 CFR: According to 1910.146(b) of the OSHA regulations "Confined space" is defined as a space that:

- Is large enough and so configured that an employee can bodily enter and perform assigned work; and

- Has limited or restricted means for entry or exit (for example, tanks, vessels, silos, storage bins, hoppers, vaults, and pits are spaces that may have limited means of entry.); and
- Is not designed for continuous employee occupancy.

Additionally CFR 29 1910.146, the OSHA General Industry Permit-Required Confined Spaces Standard, contains requirements for practices and procedures to protect workers in general industry who perform confined space work. The standard requires all employers, including telecommunications companies, to determine if their workplaces contain any confined spaces that meet the definition of a permit-required confined space. Permit-required confined spaces meet the following criteria.

- Contains or has a potential to contain a hazardous atmosphere,
- Contains a material that has the potential for engulfing an entrant,
- Has an internal configuration such that an entrant could be trapped or asphyxiated by inwardly converging walls or by a floor which slopes downward and tapers to a smaller cross-section, or
- Contains any other recognized serious safety or health hazard.

Therefore, all general industry employers, including telecommunications companies, must investigate all confined spaces to determine if working conditions are safe and healthful ³.

Confined spaces generally are considered by most to be manholes or sewers, but other communication industry areas that may be defined as a confined space include: splicing vehicles, garages, tunnels, loading docks, warehouses, and vehicle repair shops.

Confined space work may also involve work with and exposure to isocyanides contained in telecommunications plugging/splicing compounds. Commonly used plugging compounds include isocyanate compounds such as toluene diisocyanate (TDI) and methylene biphenyl diisocyanate (MDI). Of particular concern, inhalation to isocyanate products may cause nausea, vomiting, abdominal pain, and breathing problems. In addition, exposure may cause sensitization among affected workers to isocyanate products like TDI and MDI. In turn, further exposure may lead to workers suffering severe allergic reactions that could result in death. There is also the possibility of exposure to fumes from hazardous solvents or degreasers including carbon tetrachloride, trichloroethylene, trichloroethane, perchloroethylene, trichlorotrifluoroethane, and mineral spirits. The danger in using solvents in confined spaces varies according to the type of solvent and the duration and intensity of exposure ⁴.

Ergonomic hazards exist in confined space work. There is little that can be done to mitigate the hazards from the physical environment because of the design and structure of most confined spaces. There is also the nature of the work that has to be completed in the confined space that may pose hazards. These potential hazards include electricity, scaffolding, surface residues, and structural hazards.

While electrocution or electrical shock is not the major cause of fatalities in confined spaces, a study by The National Institute for Occupational Safety and Health (NIOSH) indicates it has been a factor in several injuries and deaths in confined spaces (www.cdc.gov/niosh/).

The use of scaffolding in confined spaces may contribute to accidents caused by workers or falling materials. Surface residues in confined spaces can increase the already hazardous condition of electrical shock and bodily injury due to slips and falls.

III. Wireless Safety Issues

In the United States, the wireless industry maintains a unique construction and maintenance model. Tower maintenance and construction is managed by large construction management firms referred to as “Turf Holders”. These construction management companies then find master subcontractors to divide the work. The master subcontractors hire and manage small locally owned subcontractors who are responsible for getting the actual work done. Because the work is getting split up by so many layers of subcontractors, there is intense pressure to keep costs down at the lowest layer. This pressure has resulted in lack of government oversight, lack of appropriate training, and numerous fatalities, figure 3.

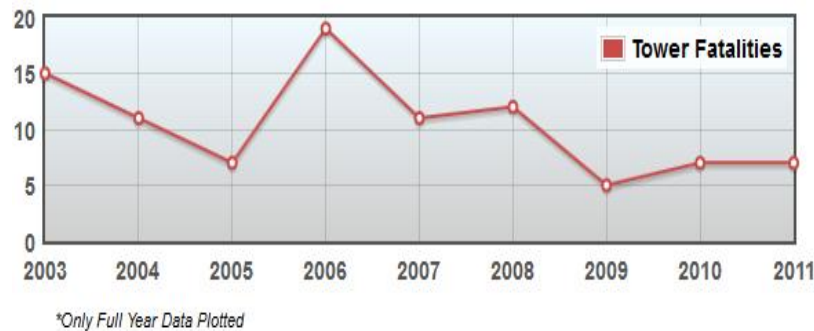

2012 Fatalities Total: 0

2011 Fatalities Total: 7

Figure 3. Tower Fatalities 2003-2011 ⁵.

One of the reasons for the numerous safety issues, including 50 fatalities over the last decade, is the sheer number of cell towers in operation. As of a survey of the top 90 cell phone tower companies in the United States included: 99,930 with the top three providers owning 88,512 or nearly 89% of the market. The breakdown can be seen in chart. In the United States there are roughly 10,000 tower climbers or 9.3 towers per climber, table 1 below.

Where OSHA has a direct access to the wire line companies for enforcement, the structural environment in the wireless industry is completely different. With numerous layers of sub-contractors, the Wireless industry has many legal and organizational layers of obfuscation that exist between the decision makers and the workers. There is only one cited case where OSHA attempted to take legal action against a wireless carrier for the falling death of a tower subcontractor. The case was dismissed. In this environment there is little incentive for the carriers to make worker safety a high priority. There isn't even a formal record that connects the carrier with the sub-contractor fatality. The turf vendors are insulated from government oversight from a similar model of sub-contractors under them ⁷.

Table 1 - Top Tower Owners

Rank	Tower Owner	Towers
1	Crown Castle	22251
2	American Tower*	21644
3	AT&T Towers	10312
4	SBA Communications	9290
5	T-Mobile Towers	8782
6	United States Cellular Co.	4802
7	Global Tower Partners	4150
8	TowerCo	3295
9	Mobilitie	2586
10	Verizon Wireless	1400
	Total:	88512

Note: *American Tower Corporation's tower count reflects only domestic structures. The company owns additional towers internationally. Its most current total tower count is approximately 38,000* ⁶.

There is a stark difference between the structure of the American wireless industry and its safety record versus that of the rest of the world. International benchmarks are more difficult to obtain due to less communications between rigger companies and limited reports from English news media in foreign speaking companies. There were only 10 reported international tower related deaths between 2003 and 2008 where the US had 70. The case could be made that International deaths go underreported because of a less developed government reporting standards and the existence of government controlled media. There are two examples mitigate this argument. Between 2003-2008, there was only one reported fatality in Canada and zero in Great Britain. Both countries have free mass media outlets as well as extensive government reporting organizations.

These numbers would make sense if the US had seven times as many cell phone towers, but the actual number is dramatically different. According to the International Telecommunications Union (ITU), the United States cell tower portfolio is only 7% of the world's total ⁸.

One major point of difference between the countries is how they handle Subcontractors. In the majority of the world there are limited layers of subcontractors. In the instances where subcontractors are used, there is increased legislation here the authority holders are legally responsible for the health and wellbeing of the workers. As an example, in 2004 Canada introduced and passed Bill C-45 added Section 217.1 to the Criminal Code which reads:

“217.1 Every one who undertakes, or has the authority, to direct how another person does work or performs a task is under a legal duty to take reasonable steps to prevent bodily harm to that person, or any other person, arising from that work or task.”

Bill C-45 also added Sections 22.1 and 22.2 to the Criminal Code imposing criminal liability on organizations and its representatives for negligence (22.1) and other offences (22.2) ⁹.

Like most service providers, US carriers typically set many of the parameters for work on cell sites; including deadlines, pay rates, and technical specifications. As mentioned earlier in this document, unlike Canada, US carriers are insulated from legal and regulatory liability for the fatalities due to the complex layering of subcontractors in the wireless industry. The parties that are liable tend to be the smallest subcontractors. Although they can be put out of business because of a negative event such as a death, the owners of small business can quickly and easily go back into business under a different legal name.

An important point of note is that in the years between 2006-2008, there was significant growth in cell tower falling deaths with a high of 19 deaths in 2006 alone. Additionally, there were 6 cell tower deaths in 5 weeks in 2008¹⁰. Since 2003 94 climbers fell to their death. The types of towers range from radio, television, microwave, and cell towers 50 of which are cell tower deaths, figure 4. Time pressure encouraged a practice called free climbing which is climbing towers without a fall arrest system in place. Free climbing is responsible for ½ of all deaths. Cell tower deaths outnumber all other communication tower deaths combined.

Falls Resulting in Fatalities

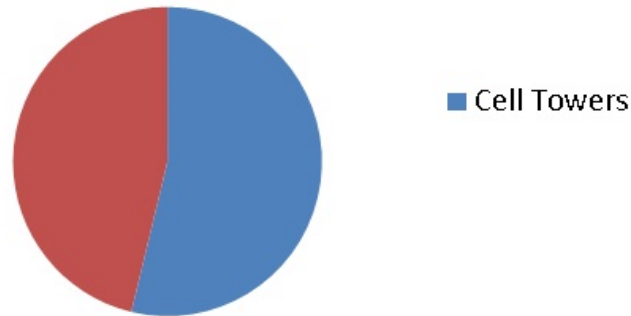

Figure 4. Falling Fatalities - All Falling Versus Cell Towers.

These events correlate very closely with AT&T's purchase of Cingular and the intense multi-year network build out necessitated by the adoption of smart phones such as the iPhone. As the wireless industry scrambled to increase capacity more pressure was placed on the different contractor layers to meet tight schedules and margins. AT&T had the most build out activity and consequently had more fatalities than all other carriers in the US combined. As a result of the increases in fatalities, AT&T issued a construction stand down for a complete safety review. There isn't any clear evidence that the stand down modified the system in any discernible way, figure 5.

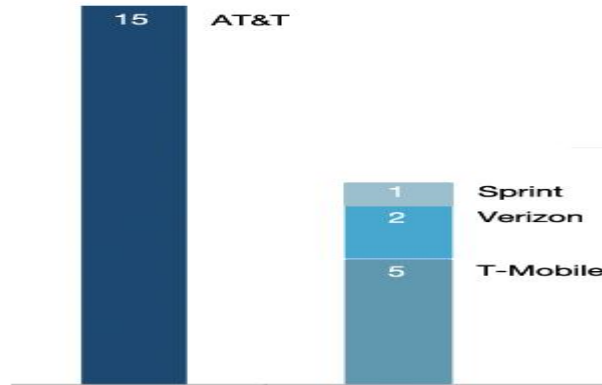

Figure 5. Fatalities by Service Provider ⁸.

IV. Optical Safety Issues

Beyond metallic wire line and wireless network connections there is another unique area that relates to safety issues and communication cables. Optical cables do not conduct electromagnetic energy so there is limited chance of electric shock when engaged in inside plant fiber optic work. There are some situations where there may be electrical hazards in outside plant applications. In all applications, optical cables carry very high intensity of laser light. Workers involved in fiber optic cable installation or repair may be at risk of permanent eye damage due to exposure to laser light during cable termination, connectivity and inspections. There is a polishing process involved in preparing the end of a fiber optic cable for connectorization. When extending a cable or mounting a cable connector, a microscope is typically attached to the end of the fiber optic cable allowing the worker to inspect the cable end to confirm its surface area is smooth and ready for the connector assembly.

Nearly all communication systems use infrared light to communicate, meaning the technician will not see any light. The fiber optic wavelengths used are adjacent to visible light in the electromagnetic spectrum which is why they can cause damage to an unprotected eye, figure 6.

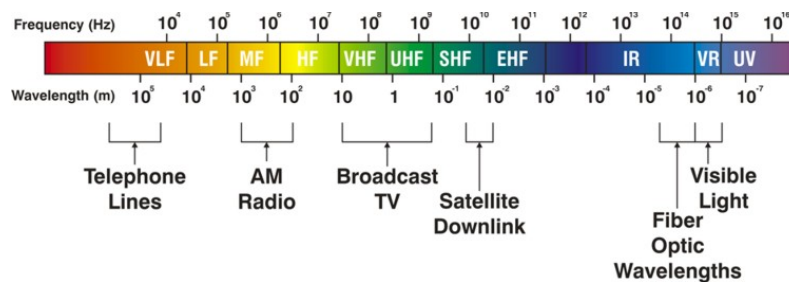

Figure 6. Electro-Magnetic Energy Wavelengths.

Another area of safety concern is the minute or microscopic glass fiber shards that result from working with fiber optics. These fiber scraps result from working with bare fiber. A “bare fiber” is a fiber that has had the primary coating removed, exposing the fiber’s glass surface. Many scraps are created as a result of the fiber splicing and terminating activity as a result of the

cleaving process. The cleaving process is a process where a specialized cleaver is used to make a smooth break in the brittle bare glass fiber cable.

Bare fibers can easily penetrate skin and break off, causing micro-injuries. These injuries are very difficult to see and treat. When extracting with forceps the fiber scrap will may break off which will exacerbate the problem. These scraps can lead to infections in the skin, serious eye injury or internal injury from ingestion.

Another area of safety concern with optical fibers is exposure to chemicals. Some splicing or terminating procedures may require the use of adhesives, solvents, etc. The safety issues are the same as those that were cited with wire line connectivity.

The fibers themselves are dielectric, but if the cable contains any metallic parts at all, the cable is conductive and electrical shock becomes a safety issue. In many instances, there is a metallic member as a component of cable construction. These metallic components of the cable are used as strength members as well as a way to send a locating signal down the cable. The metallic members of fiber optic cables are regularly grounded in areas such as NIDS, Terminals, and Splice points. By the very nature of WAN networking these points may be miles apart which mean the technician may be working on the cable in an area where he becomes the most efficient path to ground for the electrical current ¹¹.

In the same way that gas monitors are standard equipment for working in manholes and safety harness are mandatory for working on towers, optical fiber has mandatory safety procedures and equipment. Optical scopes reduce light output of a fiber. There are special handling techniques and tools for working with bare fiber. Optical cable safety procedures include always assume that a fiber is “hot” or lit; never point any fiber at any other worker. When working with a fiber that has a metallic member, best practices include always checking the cable for inducted voltage.

V. Conclusions

Safety issues are unique for wire line, wireless and optical cables. In all instances of modern telecommunications there are significant safety concerns. These concerns range from electrical and falling fatalities to permanent damage from lasers and incurable skin injuries.

There are some issues such as those relating to confined spaces and working with optical fiber where a greater focus on safety training would be an effective stop gap in reducing injuries.

The situation is much more complex when it comes to fatalities from falling from cellular towers. The fundamental makeup of the multi-level subcontractor structure creates a situation where safety focus continue to be diluted to the point where there is little to no interest in safety at the worker level.

VI. References

- [1] G. Miller, “GETTING EQUIPPED: Utility Poles,” *Electrc Light and Power*, 2012.

- [Online]. Available: <http://www.elp.com/index/display/article-display/279131/articles/utility-automation-engineering-td/volume-11/issue-10/features/getting-equipped-utility-poles.html>. [Accessed 14 5 2012].
- [2] Communications Workers of America, “OSHA Faults Verizon in Death of Brooklyn Technician Douglas Lalima,” CWA, 19 March 2012. [Online]. Available:
- [3] http://www.cwaunion.org/news/entry/osha_faults_verizon_in_death_of_brooklyn_technician_douglas_lalima/#.UIwglYbZ0cS. [Accessed 16 May 2012].
- [4] United States Department of Labor, “Regulations (Standards - 29 CFR),” United States Department of Labor, Washington DC, 1998.
- [5] CWA Occupational Safety and Health Department , “Confined Spaces and the Workplace,” Communications Workers of America, Washington DC, 2009.
- [6] Wireless Estimator, “US TOWER STRUCTURE RELATED FATALITIES”,” 6 June 2012. [Online]. Available: <http://www.wirelessestimator.com/generaldoc.cfm?ContentID=9>. [Accessed 29 July 2012].
- [7] Wireless Estimator, “Tower Companies,” [Online]. Available: http://www.wirelessestimator.com/t_content.cfm?pagename=US-Cell-Tower-Companies-Complete-List. [Accessed 10 October 2012].
- [8] J. Barab, Interviewee, Why OSHA Can’t Cite Cell Carriers for Worker Safety Violations. [Interview]. 22 May 2012.
- [9] C. Lekutis, “Schedule and margin pressures seen as possible reasons for higher death count of techs in the US,” 14 August 2009. [Online]. Available: http://www.wirelessestimator.com/t_content.cfm?pagename=International%20Tower%20Climber%20Deaths. [Accessed 4 June 2012].
- [10] Canadian Centre for Occupational Health and Safety, Bill C-45 Overview, Ottawa, Canada: Canadian Centre for Occupational Health and Safety, 2004.
- [11] P. Elmer-Dewitt, “Fatal bandwidth: 6 cell tower deaths in 5 weeks,” CNN Money, 28 mAY 2008. [Online]. Available: <http://tech.fortune.cnn.com/2008/05/28/fatal-bandwidth-6-cell-tower-deaths-in-5-weeks/>. [Accessed 4 June 2012].
- [12] K. Norris, “Splicing Fiber: The Untold Story,” Outside Plant Magazine, February 1999.

Biography:

Dr. Ibraheem Kateeb is the section chair of Central NC section and a Senior Member of IEEE with over 25 years of experience in academia and industry. He received his Ph.D. from NCA&TSU. He is currently at NCA&TSU as Assistant Professor of Computer Systems Technology Department. His current research is on power and green energy, electronics and control/robotics. In the last two years, he published more than 27 journal and conference papers and has many projects and grants in power, renewable energy and smart grid related issues. Dr. Kateeb was recognized as the recipient of Academic Excellent Award from CARTS International 2012 (Electronic Components Industry Association, ECIA) for one of his research papers.

Khaled F AlOtaibi is currently a PhD candidate at North Carolina Agricultural and Technical State University USA. He received his B.S. in Electrical and Computer Engineering from King Abdulaziz University, Saudi Arabia in 2005, M.S. from North Carolina Agricultural and Technical State University, USA in Computer Science Software Engineering in 2009. His research interest is in the application of the control to power system.

Michael S. Peluso received his MS from the Computer Systems Technology at NCA&TSU, he is an adjunct instructor at a community college in NC, and a Ph.D. student at A&M State University.

Dr. Larry Burton received his BS, MS, and Ph.D. in electrical engineering from Duke University. He has 25 years executive international management experience in technology-based businesses, and holds ten patents in microwave and optical communications, video switching, and broadband infrastructure. His current research is focused on high availability / high reliability enterprise computing.

Dr. Evelyn R. Sowell has been an adjunct assistant professor of Information Technology in the Computer Systems Technology department at North Carolina A&T State University's School of Technology since 2009. Dr. Sowell has earned a Ph.D. in Electrical and Computer Engineering from North Carolina A&T State University's College of Engineering. She also holds a M.S. and B.S in Computer Science with a concentration in software engineering. Her primary research interests are low-power high performance, asynchronous and self-timed digital system design, particularly, the development of power aware algorithms and techniques for system timing optimizations. Specific interests include portable digital electronics and high performance computation. Evelyn is also a member of Upsilon Phi Epsilon, Computer Science Honor Society.

The Fundamental Component of Telecommunications Cabling

Dr. Ibraheem A. Kateeb, Khaled F. AlOtaibi, Dr. Larry Burton, Michael S. Peluso,
Dr. Evelyn R. Sowell

North Carolina A&T State University, Greensboro, NC, USA

kateeb@ncat.edu, khaled_u2@hotmail.com, lwburton@ncat.edu, peluso72@gmail.com,
es992760@ncat.edu,

Abstract

The fundamental building block of last mile broadband connections for the telecommunications industry is the copper cabling systems that have traditionally underpinned the networks. Time has seen tremendous change in this core component of the network, with result being silica-based fiber optics are championed as the de facto replacement technology for traditional copper cabling in the last mile.

This paper will provide a survey and discussion of the current status of copper cabling in networks. It will examine the strengths of copper verses fiber optics. It will explore the effectiveness of recent technological advances made in delivering broadband over copper. It will also review the current economic models relating to cable deployments. Finally, an analysis will be presented that attempts to answers the question of phasing out copper.

Keywords-Telecommunication cables, copper cable, fiber optics, last mile, digital subscriber line, passive optical networks.

I. Introduction

The fundamental component of telecommunications is the actual physical cable that connects the world's networks to each other and to end-users. The internet introduced the greatest change in the history of telecommunications. It forced copper based networks originally designed for single service applications such as voice to multi-service applications including voice, video, and broadband data. It has also changed the network policy the world over with legislation and cultural attitudes that advocate phasing copper based solutions out of the last mile of the telecommunications network in favor of fiber optics.

This paper will explore the question "Should copper cables be phased out as last mile broadband solutions?" In order to determine an answer to this question, many aspects of cabling will be reviewed, including the current political and social climate relating to last mile broadband technologies. It will explore the physical and reliability characteristics of the different cable types. It will review the economics relating to cable types from a service provider and a user perspective.

The findings will note there is limited evidence suggesting that copper cables should be phased out as last mile broadband solutions. Costs, technological advances, existing infrastructure, political climate, and macroeconomics all play a role in determining what cables best will serve the needs of the network owners and users.

Section II gives brief history of copper cabling. Section III discusses brief history of fiber optic cabling. In Section IV, we discuss about the current climate and attitudes relating to the copper versus fiber debate. Section V discusses physical characteristics of copper and fiber based Telecommunication cables. In Section VI, we discuss about consumer economics of fiber optic vs. copper networks. Section VII discusses service provider economics of fiber optic vs. copper networks.

II. A Brief History of Copper Cabling

The birth of current copper based telecommunications systems can be traced to May 1st 1844. It was on this date that Alfred Vail and Samuel Morse used their partially completed electrical telegraph to send the news of Henry Clay's nomination from Annapolis Junction, Maryland to members of Congress at the Capitol in Washington DC. This was full hour-and-a-half quicker than the message was able to get to the Capitol by human carrier. It was this event that proved how much more effective even the most basic telecommunications system was at transferring information than any other method used throughout the whole of human history ¹.

Even as rudimentary as the electrical telegraph was, the cost to build it was prohibitive, so monies had to be appropriated from the federal government. The amount required at the time was \$30,000, or close to \$773,000 in today's dollars [www.measuringworth.com]. This very first example of the prohibitive costs of network deployments has been echoed throughout the history of communications up until the modern era. It also directly affects the ability of modern day broadband service providers to phase out existing networks in lieu of newer equivalents.

The telephone network used the same type of network cable as the telegraph, but could carry a modulated signal that could recreate complex sounds such as voice. The popularity of voice service eventually replaced telegraph service as the primary communication network in use. In many instances, electrical and telephone networks were simultaneously located on similar, parallel paths. The electrical networks caused telephone signal interference, which necessitated the invention of a process known as "wire transposition" ². In a wire transposition implementation, the wires exchange position every few phone poles, thus eliminating the interference. Wire transposition eventually led to the creation of unshielded twisted pair cabling (UTP). The following Fig.1 shows an example of wire transposition. Transposition was implemented approximately every 3-4 poles which resulted into approximately five to six twists per mile.

An alternative means to offer broadband over copper cable is coaxial cable (coax). Lloyd Espenschied and Herman A. Affel, engineers who worked for the American Telephone & Telegraph Company, were awarded U.S. Patent No. 1,835,031 in 1931 for a "concentric conducting system". This invention was the core of coax. ³. It is named "coaxial" because two conductors share the same axis: one conductor is at the center of the cable, and the second is wrapped around it. This design minimizes signal degradation from external electromagnetic sources as the signal only transmits between the two conductors. The design had a specific goal in mind: to meet the need for "An enormously wide frequency range" which would facilitate both the new television technology as well as offer a more effective solution for telephone systems.

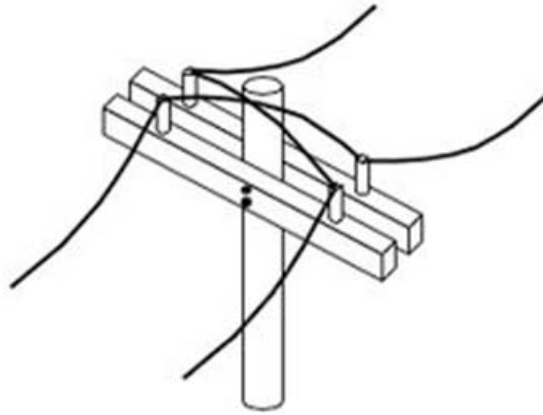

Figure 1. Example of wire transposition.

From its inception, coax was designed to provide much greater bandwidth than UTP—depending upon the age of the cable, coax can deliver between 100 MHz to 1000 MHz ⁴.

The different types of coax cable are labeled with an RG number. For example, some popular types are RG6, RG11, RG58, etc. The ‘RG’ designation has its root as a military based nomenclature for cables listed in a World War II era military specification formerly referred to as the Radio Guides. The acronym RG now stands for Radio-Frequency Government ⁵. The numerical designation is not related to the actual cable, or to its reliability and effectiveness, but to the pages in the guide where the cable specifications are located. For example, RG6 is on page 6 of the radio guide it is listed in. Following World War II, veterans who maintained a strong familiarity with the numbering scheme secured jobs in the broadcasting industry and extended its use there. Thus, the standard coax nomenclature was permanently adopted ⁶.

UTP became the standard cable used by traditional telecom companies to provide the last mile link for broadband services via a technology known as Digital Subscriber Line (DSL). There are several variants of DSL including multiple versions of Asynchronous Digital Subscriber Line (ADSL), as well as multiple versions of Very-high-bit-rate digital subscriber line (VDSL). The main difference between these different flavors of DSL technology is the speed offered and the distance that broadband can be offered in the last connection the digital subscriber line access multiplier (DSLAM) at the local exchange (LE) to the premise ⁷. Fig. 2 shows distance range for different standards of cables

Coax became the standard cable used to deliver broadband services via the Data Over Cable Service Interface Specification (DOCSIS). There have been several generations of DOCSIS with the latest being DOCSIS 3.0. This latest generation of DOCSIS achieves speeds of up to 120 Mb/sec up and 160 Mb/sec down.

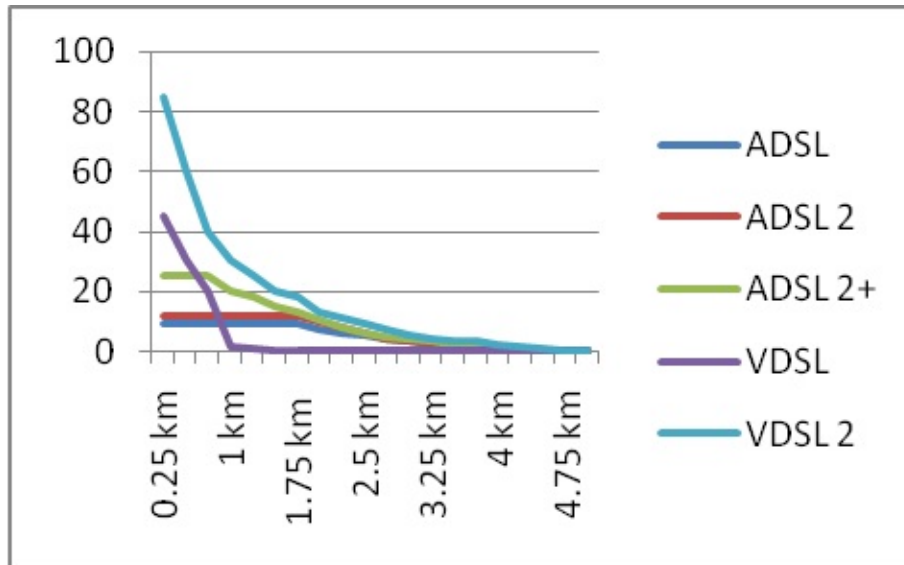

Figure.2 Distance range for different types of cables.

III. A Brief History of Fiber Optic Cabling

Comparatively speaking, of the types of telecommunication cabling, fiber optic cable has a history of the most disparate contributions. The invention and use of fiber optic cable occurred in stages. For example, initial research involved the use of glass tubes for dental and medical applications including dental illumination and internal imaging. Clear tongue depressors were developed for dental offices to deliver light into the mouths of patients. Additionally, the insertion into the body of an optical tube was less invasive than an operation for seeing inside a human body. Further research was done throughout the 1930's on transporting images through clear tubing, but the next critical development that moved fiber optics forward occurred in 1954 when Abraham an Heel invented a cladding fiber with a lower refractive index when applied over a core of glass. By the 1950's, glass-clad fiber had an attenuation of one decibel (dB) per meter, adequate for the original purpose of medical imaging but too high for the purposes of communications⁸.

The laser was invented in 1960, and this spurred interest and experimentation in using optical fibers as a communications technology. For optical fiber to be effective for communication purposes, researchers needed a cable with attenuation of less than 20dB/KM. This was accomplished in September 1970 by Corning Glass researchers who created a fiber optic cable out of fused silica with attenuation below 20dB/km. Robert Maurer, Donald Keck and Peter Schultz invented fiber optic wire or "Optical Waveguide Fibers" (patent#3,711,262) through which information carried by a pattern of light waves could be decoded at a destination even a thousand miles away. The fiber optic wire was capable of carrying 65,000 times more information than copper wire⁹. This achievement heralded the beginning of modern fiber optic networks. In 1977, the first optical telephone communication system was installed about 1.5 miles under downtown Chicago, and each optical fiber carried the equivalent of 672 voice channels¹⁰.

IV. The Current Climate and Attitude Relating to the Copper vs. Fiber Debate

Let's examine the coax cable used for cable television. It has lots of bandwidth, but it even cheaper than telephone wire to install. CATV systems are using this coax for everything including television signals, Internet connections, and even voice over IP. However with the rapid evolution in data transmission, it is now being quickly converted to fiber, which provides the backbone connectivity due to lower loss and much greater reliability which in turn, translate into cost savings. In most data transmission, fiber and copper coexist, with each being used where the economics dictate.

The wire we use for LANs is a lot younger than fiber optics. Fiber use is over 20 years old, but computer networks on unshielded-twisted-pair cable (UTP) have only been around about 15 years. In that time, UTP has gone through at least 5 generations, each time to keep up with the increasing bandwidth requirements of LANs. Today, voice over IP has replaced the "telephone wire" that once was.

The copper cabling manufacturers technical efforts to expand the capacity of UTP cabling in order to keep up with the ever expanding networks has produced extraordinary results in terms of product development which include the electronic platform that assist in getting the signals off and on the cabling.

When we examine the down side, the achievement of maximum performance is still in question. Recently, a number of magazine articles and even a representative of AMP were quoted as saying that as much as 80-90% of all Cat 5 cabling was improperly installed and would not provide the rated performance. Contractors have told us that 40% of their Cat 6 installations pass certification tests.

The performance of the Cat 5 cable is dependent on close control of the physical characteristics of the cable and the materials used in the insulation. Untwist the wires too much at a connection or remove too much jacket and the cable may fail crosstalk testing. Pull it too hard (only 25 pounds tension allowed!) or kink it and loss the performance you paid for.

Even if top performance is not necessary, getting all 8 of the wires connected correctly requires a lot of care.

The genesis of the question underpinning this paper comes from the current world-wide attitudes on telecommunications cable. Currently, political pressure is being exerted against the use UTP in favor of fiber ¹¹. The general consensus among world leaders is clear: they are supporting legislation driving universal access to broadband, the preference being for fiber optics over copper. There are differing regional attitudes about cable deployment, and it is important to emphasize that attitudes in one part of the world may impact attitudes and adoption rates elsewhere.

Starting in 2001, for example, nearly no Fiber to the Home or Business (FttH/B) solutions was deployed. Today, the number stands at approximately 50 million—this many homes and business receives broadband via FttH/B. The breakdown in subscriber numbers and regional preferences

can be seen in the following graph. The highest numbers belong to the United States, Japan, China, Europe and Russia. Fig. 3 shows same 2011 FTTH/B subscribers.



Figure 3. 2011 FTTH/B subscribers

In October, 2011, Neelie Kroes, vice-president of the European Commission in charge of the Digital Agenda, unveiled proposals to accelerate investment in fiber networks. She proposed two models targeting changing the wholesale access pricing on existing copper networks. The first forecasts a gradual reduction in wholesale prices for universal access to existing copper networks, the resulting fall in retail broadband prices encouraging incumbents to move to fiber networks. The second forecasts incumbents escaping at least part of the price cuts if they agree to switch off their copper networks switch within a certain period and adopt fiber ¹¹.

Despite the growth rate of FttH, abandonment of copper-based solutions, as espoused by Kroes, may be premature because copper—the older, time-tested solution—is entrenched in certain markets, and technological advances involving the deployment of copper are still occurring and making their way into the market. British Telecom in the United Kingdom, for example, has been marketing 20 Mbit/sec connections over legacy twisted pair using ADSL2+ since 2011¹². According to the British approvals service for cables, network cable has a life span that can reach 50 years ¹³. It is for this reason network build outs are amortized over decades by large service providers. Comparatively speaking, fiber optic cable has been in service for less than 25 years as a viable communications platform. From the service provider’s perspective, in some instances fiber has to compete with network cabling that is still expected to provide 25 years more service. The economics of cable types will be discussed further in this study.

V. Physical Characteristics of Copper and Fiber Based Telecommunications Cables.

In order to answer the question, “Should copper cables be phased out as last mile broadband solutions?”, a review of the physical characteristics of the different cable types is of interest. The outside plant can be a harsh environment- weather, human interaction, animals, and many other

factors can negatively affect cable. Operating expenditures associated with maintaining an outside plant are very costly to fixed line telecommunications service providers. The physical characteristics and reliability of different types of cable will have a direct impact on what types of cables continued to be deployed. There are many similarities between UTP and coax based on the fact that both are made of copper and depend on a dual conductor arrangement for effective communications. Although there are some reliability issues unique to each cable type, both suffer from many of the same deteriorative factors. Fiber optic cables are based on a completely different technology and only require a single conductor for transmission of light. In terms of use, each cable type has strengths and weaknesses which make it difficult to determine which one is the most reliable.

Twisted pair cable is unique in that its conductor and insulating jacket are very small. This makes twisted pair highly susceptible to breaks, stress, and improper twists. Additionally, twisted pair is manufactured and deployed in very large bundles so the potential for splitting pairs and electromagnetic crosstalk between pairs is very high. This crosstalk is one of the major limiting factors in using UTP to provide higher broadband speeds. A new technology called Phantom Mode may correct the problem and allow for speeds in excess hundreds megabits per second¹⁴. Coaxial cable jackets are susceptible to ultra violet radiation, and will deteriorate over time when exposed to the sun or another source of ultra-violet (UV) light. Coaxial cable also tends to have more issues with its larger connectors if they are not affixed properly.

Some similarities between the two cable types involve moisture and interference. Moisture causes two main detrimental effects to copper telecommunications cable. First, when moisture is present in a copper conductor it can cause oxidation. This will give rise to an increase in the level of attenuation in copper based cable. Second, when water vapor is absorbed into the dielectric insulating member of the conductor and power is passed through the cable, the reduced dielectric properties of a vapor filled insulator will conduct some of the electromagnetic energy and convert it into heat. In all cases the cable becomes less effective. Because both UTP and coax are metallic, both are susceptible to interference by high levels of electromagnetic energy which can couple onto the cable. Coupling can be an especially acute problem if there is a flaw in the cable jacket¹⁵.

When considering the reliability of fiber optic cable, two areas affect its viability. Degradation can be caused by stress and fatigue, but also by slow changes in the cable over time. Abrasion caused by foreign particles on the fiber surface can cause fatigue and damage to the fiber. These particles generally result from poor manufacturing, handling, or installation. Stress also affects cable viability. "High stress" typically is encountered during installation, repair, or reconfiguration of the cable while "low stress" is sustained under normal conditions over long periods of time¹⁵.

High stress failures are easy to visualize. A technician who bends a fiber too tightly may see the fiber break. A failure of a component on the manufacturing line may produce highly flawed fiber that meets minimum specification, but undoubtedly will fail over time.

Low stress failures are more difficult to envision. It is important to remember that fiber is made of glass. As an example, anyone who has ever experienced a rock hitting the windshield of a car

knows that glass cracks. Over time, the cracks will spread as a result of the stress the windshield is under due to various driving and weather-related conditions. A fiber works much the same way, micro abrasions causing cracks that will spread over time and eventually cause failure ¹⁶.

Ultimately, there are benefits and detriments to the physical aspects of each cable type. These pros and cons make it difficult to determine if a cable type should be removed from use in the last mile of the outside plant based upon these differences alone. Other aspects must be considered to determine copper's viability as a broadband solution in the outside plant.

VI. Consumer Economics Of Fiber Optic vs. Copper Networks

Business and government are generally early adopters of new technologies, and earlier the authors cited how government became involved with telecommunications from the very first transmission. This is primarily due to the higher initial cost of implementing any new technology. As economies of scale ramp up and refinements are made in manufacturing and distribution, services and technologies generally tend to evolve into consumer offerings. At that point, mass adoption lowers cost.

Globally, broadband costs have shrunk dramatically in recent years. Consumers and businesses are paying on average 18% less for entry-level Information and Communication Technology (ICT) services than they were two years ago - and more than 50% less for high-speed Internet connections, according to figures released by the International Telecommunications Union ¹⁷. Fixed broadband (hard line) pricing is dropping the most (at over 52%) while wireless broadband access is also dropping appreciably (at nearly 22%) as the following table illustrates

According to the World Bank, in Ireland the price of an ADSL connection for a business user fell 74 percent between 2005 and 2008. In Turkey, the drop was 57 percent; and in Peru, 17 percent ¹⁸. Table I gives different price basket over the years. Although pricing is dropping quickly, in many parts of the world, broadband is prohibitively costly based on per capita income. For example, in heavily-populated developed countries with mature economies —France, England, Germany, the United States—the price for broadband has fallen so much that it's approaching only 1% of monthly income.

This is due to aggressive competition and government /private partnerships aimed at expanding fixed line based broadband to a broad base. One further example can illustrate this point: in late 2011, Comcast and Century Link started offering a \$9.95/month service that provides 1.5 Mbps downstream to low income families in many cities across America, and their respective programs also included subsidized computer hardware ¹⁹.

By contrast, in 32 less-developed countries, the monthly price of an entry-level fixed broadband subscription corresponds to more than half of the average monthly income. In 19 of those countries, a broadband connection costs more than 100% of monthly Gross National Income per capita (GNI), and in certain developing countries the monthly price of a fast Internet connection is still more than ten times the monthly average income ¹⁷. The following graph in Fig. 4 illustrates this data.

Table 1. Different price basket over the years.

Price Basket	2008	2010	Average Absolute value change	Average Percentage Value Change
ICT Price Basket	15.2	12.4	2.8	18.3
Fixed phone sub-basket	6.2	5.8	0.4	6.9
Mobile service sub-basket	11.0	8.6	2.4	21.8
Broadband sub-basket	165.0	78.9	86.1	52.2

These prohibitively expensive scenarios have resulted in a market that is underserved. In short, there is ample opportunity for existing copper-based broadband networks to grow worldwide. Worldwide, less than a quarter of fixed telephone lines have been upgraded to DSL broadband connections¹⁸. Additional data can be seen in the following table which shows by region the percentage of DSL penetration compared to total voice lines.

There are different aspects to consider when we debate displacing copper cable with fiber optics. One major difference between the two technologies is bandwidth. Fiber optics can provide superior levels of bandwidth to end users. A generally accepted belief is that for greater functionality users of broadband will need higher speeds. There are numerous estimates of bandwidth requirements for various types of digital content. For instance, The Organization for Economic Co-operation and Development (OECD) suggests that bandwidth requirements for online games, video on demand, and videoconferencing range from 2 to 14 Mbit/sec²⁰.

Booz & Company, an international broadband consulting firm, approaches broadband speeds as generational. They consider the first generation offering 512 Kbit/s to 2 Mbit/sec to be adequate for rich media, social networking, and videoconferencing. Their belief is that next generation broadband will include applications such as next generation TV and tele-learning. As a result, Booz & Company estimates next generation bandwidth requirements at more than 20 Mbit/s, and that future data services should also be of high quality²¹. What is most interesting about the above information and the resulting conclusions is that copper solutions including DOCSIS and many of the implementations of DSL are compatible with all such scenarios.

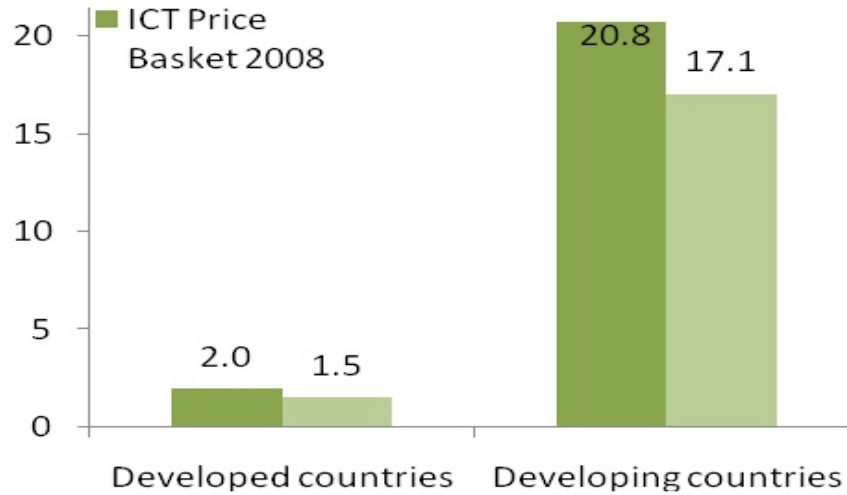

Figure 4. ICT Price basket in developed and developing countries

Table 2. Different regions with DSL/Total Mainlines Percentage.

Region	DSL/Total mainlines
East Asia & Pacific	15.1%
Eastern Europe & Central Asia	4.8%
European Union (EU-27)	29.1%
Latin America & Caribbean	4.0%
Middle East & North Africa	6.2%
North America	37.9%
South Asia	0.2%
Sub-Saharan Africa	4.6%
World	12.8%

According to a study based on business class internet service that was commissioned for the United States Small Business Association (SBA), DSL offers the lowest cost broadband service by type. The following graph in Fig. 5 shows the average monthly price for internet connection by type and compares xDSL versus the cost of competitive technologies ²².

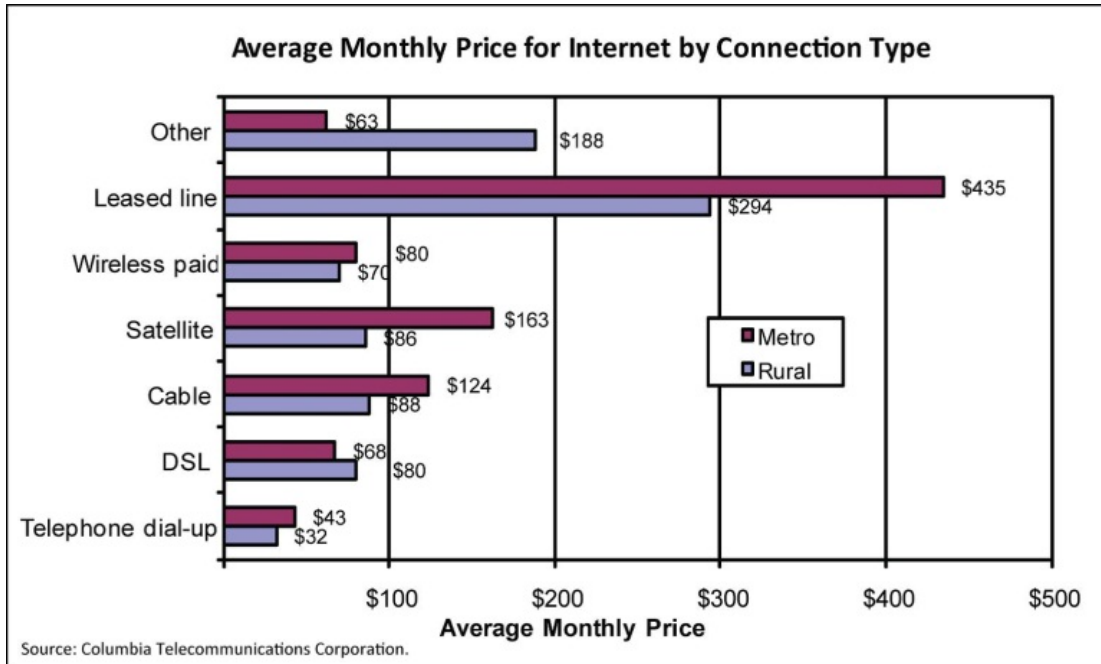

Figure 5. The average monthly price for internet connection by type and compares xDSL versus the cost of competitive technologies

The European Union commissions an annual comparative study on broadband internet access costs in 27 member states of the European Union as well as Canada, Croatia, Iceland, Japan, South Korea, Liechtenstein, Macedonia (FYROM), Norway, State of California, State of Colorado, State of New York, Switzerland and Turkey. As illustrated in the following chart, the latest data from the 2011 report shows that copper solutions such as cable broadband and DSL maintains the lowest cost option for broadband consumers. Fig. 6 shows different market share of technology.

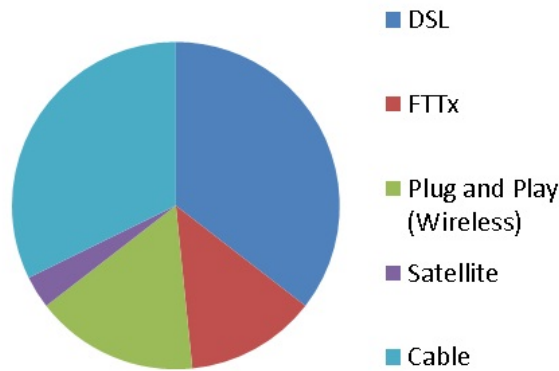

Figure 6. Different market share of technology.

When considering the total market for all speeds and all technologies, twisted pair copper has commanded a historical lead, and even with tremendous competition from fixed wireless, Fiber to the x (FTTx), and cable, DSL still maintains roughly 80% market share²³. This can be seen in the Fig. 7.

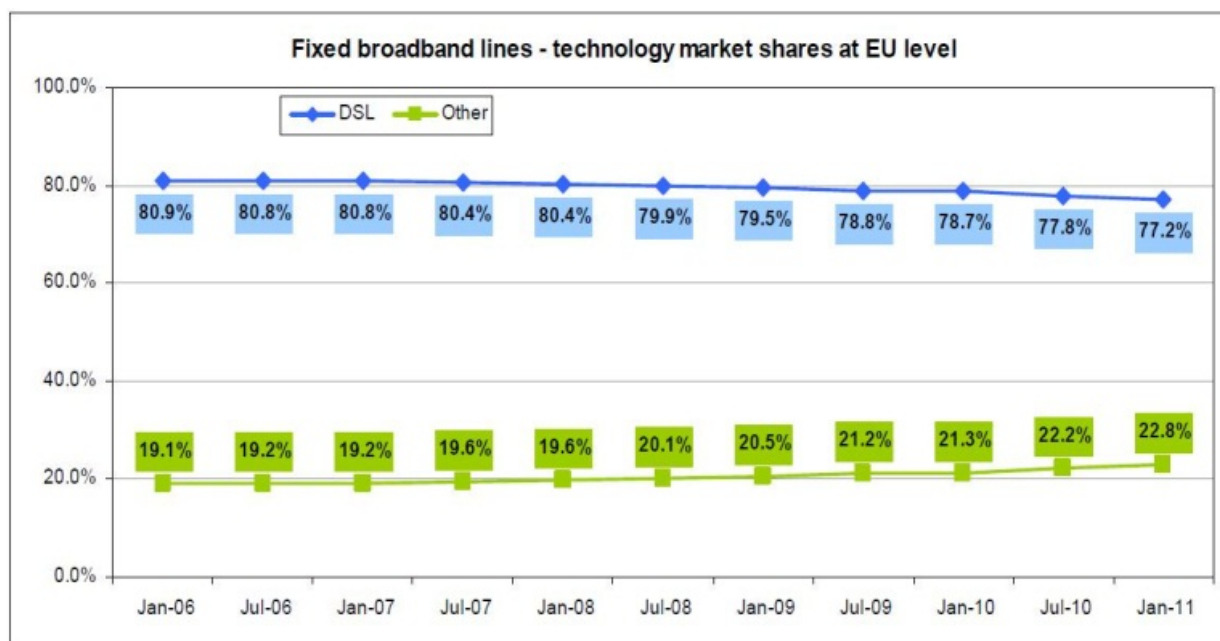

Figure 7. Fixed broadband lines-technology market shares at EU level.

From the perspective of the broadband consumer, the data clearly shows a distinct benefit to keeping copper based solutions for the foreseeable future. Copper based solutions offer the best prices and the greatest opportunity for broadband growth.

VII. Service Provider Economics Of Fiber Optic vs. Copper Networks

The bandwidth benefits of fiber optics are well known and fiber is the standard for back haul operations of almost all telecommunications networks. The deployment question concerns its lack of mass adoption by network providers for the last mile of their networks. The answer has much more to do with economics of network operations than it does in the effectiveness of it. It is simply not cost effective to deploy a Fiber to the Home/Business (FtH/B) end to end fiber optic network.

As an example, CATV companies currently prefer a Hybrid Fiber-Coax (HFC) network where fiber is used in the backbone and Coax is used for the distance from the fiber termination point to the home. This provides enough bandwidth to allow the CATV companies to offer a plethora of services including traditional video entertainment, video on demand, high speed internet, and telephony. It also significantly reduces the need for expensive fiber optic electronics at both the headend and at the customer premise.

In an all fiber Passive Optical Network (PON), the cost for the “drop” from the WAN to the customer premise is \$748.00. In a HFC deployment only a traditional coax drop is required, which costs an estimated \$125.00. The savings are just as stark when it comes to headend equipment. In a network cost analysis costs are measured per Outside Plant mile. Costs are incurred for both the Outside Plant and headend equipment. In an FtH PON deployment the costs for headend equipment is \$16,118 per mile. The cost for outside plant deployment is \$26,084 per mile. Comparatively in a HFC deployment, the costs for outside plant deployment is

\$28,682 per mile but the headend equipment is \$820 per mile ²⁴. The stark nature of the difference of these numbers can be seen in the following graph in Fig. 8.

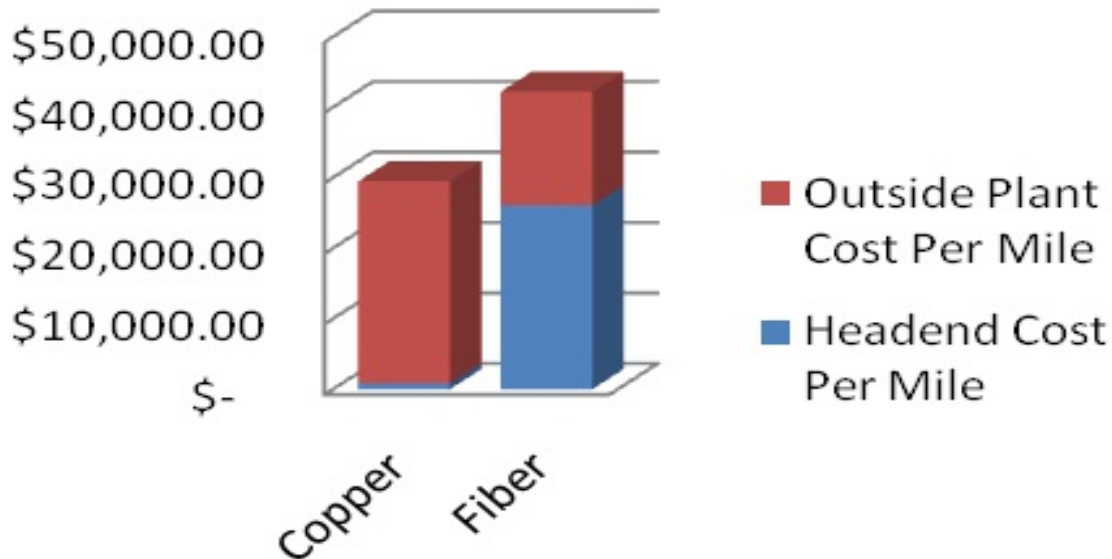

Figure 8. The copper vs. Fiber cost comparison.

The market continues to remain dynamic as major corporations such as Google experiment with their own FttH/B build outs ²⁵. It will take time to see how this new competitive pressure affects the industry.

From a purely economic model, displacing copper cable in favor of fiber optics does not make economic sense for service providers or for consumers. It is especially true for service providers who would need a significant return on investment to replace copper with fiber. In fact, there are examples of telecom companies that have stopped deploying fiber optics because of the economics. Verizon, the largest fixed-line provider in the United States, started deploying an FttH/B across its entire network, recently pulled back its fiber deployment and has decided to maintain a focus on services they can deliver over their existing copper cable based plant ²⁶.

VIII. Conclusions

Both copper cable and fiber optic cable exhibit strengths and weakness that do not identify either as a clearly superior technology.

Even with copper cable being the significantly older technology, continued improvements such as updates to DOCSIS and updates to DSL including phantom mode are driving greater bandwidth for broadband offerings. Copper cable has the added benefit of currently being the primary connection method for last mile broadband connections.

The economics of copper based solutions are stronger than they are for fiber optics for both the service provider as well as the broadband consumers. Using economic modeling alone a case can be made that it is in the best interest of telecommunications users and service provider to maintain and potentially even extend the copper networks.

Ultimately the combination of all of the above factors of technology, economics, and market share combine to provide a clear answer the question that underpins this paper. Without a doubt, there is no clear benefit to phasing out copper from the last mile of the outside plant.

IX References

- [1] S. Vail, "Alfred Vail was Morse's Partner: He helped make the telegraph a success," The New York Times, 8 May 1894.
- [2] Wikimedia Foundation, Computer Networking, San Francisco, CA: Wikimedia Foundation, 2012.
- [3] L. Espenschied and H. A. Affel. United States Patent 1835031, 1931.
- [4] The Fiber Optic Association, "Copper or Fiber? What's the real story?," 17 5 2012. [Online]. Available: <http://www.thefoa.org/tech/fo-or-cu.htm>.
- [5] R. Shimonski, R. T. Steiner and S. M. Sheedy, Network Cabling Illuminated, Sudbury, MA: Jones and Bartlett Publishers, Inc., 2006.
- [6] S. H. Lampen, Wire, Cable, and Fiber Optics for Video and Audio Engineers, Columbus, OH: McGraw-Hill, 1997.
- [7] L. Vidmar, B. Peternel, M. Štular and A. Kos, "Broadband access network investment optimization in rural areas," MELECON 2010 - 2010 15th IEEE Mediterranean Electrotechnical Conference, pp. 482-486, 2010.
- [8] J. Hayes, Fiber Optics Technician's Handbook, Albany, NY: Delmar Publishers, 2006.
- [9] "COAX & Copper," 21 5 2012. [Online]. Available: <http://www.corning.com/opticalfiber/fiberbasics/companion/copper/default.aspx>.
- [10] M. Bellis, "The Birth of Fiber Optics," 7 6 2012. [Online]. Available: <http://inventors.about.com/library/weekly/aa980407.htm>.
- [11] telecompaper, "Kroes unveils plans to boost fibre investment," telecompaper, 3 October 2011.

- [12] J. Kennedy, "BT to deploy next-gen copper to 80pc of UK," 04 05 2011. [Online]. Available: <http://www.siliconrepublic.com/comms/item/21241-bt-to-deploy-next-gen-coppe>.
- [13] BASEC, "BASEC News," 1 6 2012. [Online]. Available: <http://www.basec.org.uk/News/Basec-News/Life-Expectancy-of-Cables>.
- [14] M. Peeters and V. Stefaan, "The Copper Phantom," 14 June 2012. [Online]. Available: <http://www.ospmag.com/issue/article/The-Copper-Phantom>.
- [15] "Coax cable environmental resistance," 22 5 2012. [Online]. Available: <http://www.radio-electronics.com/info/antennas/coax/coax-environmental.php>.
- [16] J. M. Matthewson, "Fiber Optics Reliability and Testing," SPIE Critical Reviews of Optical Scient and Technology, pp. 3-31, 1993.
- [17] International Telecommunications Union, ICT services getting more affordable worldwide, Geneva: International Telecommunications Union, 2011.
- [18] Y. Kim, T. Kelly and S. Raja, "Building broadband: Strategies and policies for the developing world," The World Bank, Washington D.C., 2010.
- [19] S. Donohue, "CenturyLink duplicates Comcast's \$9.95 monthly high-speed Internet offer," 3 10 2011. [Online]. Available: <http://www.fiercecable.com/story/centurylink-duplicates-comcasts-995-monthly-high-speed-internet-offer/2011-10-03>.
- [20] OECD, "OECD Information Technology Outlook 2010," Organization for Economic Co-operation and Development , Paris, 2010.
- [21] R. Friedrich, K. Sabbagh, B. Eldarwiche and M. Singh, "Digital Highways, The Role of Government in 21st Century Infrastructure," Booz & Company Inc., New York, NY, 2009.
- [22] Columbia Telecommunications Corporation, "The Impact of Broadband Speed and Price on Small Business," SBA Office of Advocacy, Washington, DC, 2010.
- [23] European Commission Communications Committee, "Digital Agenda Scoreboard 2011," European Commission, London, England, 2012.

- [24] J. Browse, "Fiber Access Network – A Cable Operator's Perspective," in ITU-T All Star Network Access Workshop, Geneva, 2004.
- [25] C. Wilson, "Google Jumps Into Gigabit FTTH," 10 2 2010. [Online]. Available: Google Jumps Into Gigabit FTTH.
- [26] K. Bode, "The Press Realizes The FiOS Party Is Over," 30 March 2010. [Online]. Available: <http://www.dsreports.com/shownews/The-Press-Realizes-The-FiOS-Party-Is-Over-107639>.

Biography:

Dr. Ibraheem Kateeb is the section chair of Central NC section and a Senior Member of IEEE with over 25 years of experience in academia and industry. He received his Ph.D. from NCA&TSU. He is currently at NCA&TSU as Assistant Professor of Computer Systems Technology Department. His current research is on power and green energy, electronics and control/robotics. In the last two years, he published more than 27 journal and conference papers and has many projects and grants in power, renewable energy and smart grid related issues. Dr. Kateeb was recognized as the recipient of Academic Excellent Award from CARTS International 2012 (Electronic Components Industry Association, ECIA) for one of his research papers.

Khaled F AlOtaibi is currently a PhD candidate at North Carolina Agricultural and Technical State University USA. He received his B.S. in Electrical and Computer Engineering from King Abdulaziz University, Saudi Arabia in 2005, M.S. from North Carolina Agricultural and Technical State University, USA in Computer Science Software Engineering in 2009. His research interest is in the application of the control to power system.

Michael S. Peluso received his MS from the Computer Systems Technology at NCA&TSU, he is an adjunct instructor at a community college in NC, and a Ph.D. student at A&M State University.

Dr. Larry Burton received his BS, MS, and Ph.D. in electrical engineering from Duke University. He has 25 years executive international management experience in technology-based businesses, and holds ten patents in microwave and optical communications, video switching, and broadband infrastructure. His current research is focused on high availability / high reliability enterprise computing.

Dr. Evelyn R. Sowell has been an adjunct assistant professor of Information Technology in the Computer Systems Technology department at North Carolina A&T State University's School of Technology since 2009. Dr. Sowell has earned a Ph.D. in Electrical and Computer Engineering from North Carolina A&T State University's College of Engineering. She also holds a M.S. and B.S in Computer Science with a concentration in software engineering. Her primary research interests are low-power high performance, asynchronous and self-timed digital system design, particularly, the development of power aware algorithms and techniques for system timing optimizations. Specific interests include portable digital electronics and high performance computation. Evelyn is also a member of Upsilon Phi Epsilon, Computer Science Honor Society.

Community Attitudes Related to Telecommunications Cables

**Dr. Ibraheem A. Kateeb, Khaled F. AlOtaibi, Dr. Larry Burton, Michael S. Peluso,
Dr. Evelyn R. Sowell**

North Carolina A&T State University, Greensboro, NC, USA

kateeb@ncat.edu, khaled_u2@hotmail.com, lwburton@ncat.edu, peluso72@gmail.com,
es992760@ncat.edu,

Abstract

One of the issues the Telecommunications industry faces is concern regarding aesthetic elements of the networks. These aesthetic considerations impact both network performance and community engagement with service providers. This paper will provide a survey and discussion of the aesthetic elements that relate to cable and outside plant infrastructure used in networks. This paper will examine historical community attitudes related to aesthetics and compare those attitudes with modern community attitudes. This paper will explore how aesthetic considerations such as outside plant cabinet color can impact network performance.

Keywords- Telecommunication cables, WAN, Community Attitudes, Aesthetics, fiber optics, telephone poles, outside plant, OSP cabinets.

I. Introduction

The aesthetic considerations of communications cable deployment have been a concern since the earliest deployments of aerial communications cable suspended on poles. The vast majority of the fierce public debate happened around the beginning of the 20th century when communications plant began en masse deployment. There was public discourse in the news outlets, acts of civil disobedience, and negotiation / legislation at the local level that led eventually to state telecommunications commissions. Later, national telecommunications regulatory bodies formed.

Over time, the majority of communications infrastructure which impacts the environment became an accepted part of the fabric of developed society. This does not mean that there has been a complete void of strong debate on the aesthetics of communications plant in the century and a half since the beginning of the mass communications era. The process of change and debate has a cyclical component. Generally speaking, as new technologies have emerged such as cell phone towers, or alternative uses of communications plant including power generation, the physical nature of these changes has been challenged again and again. Section II gives a comparison of Overhead versus Buried plant. Section III discusses a History of Phone Poles. In Section IV, we discuss issues of Communication Aesthetics in the Modern Era. Section V discusses Aesthetics of Transmission Infrastructure.

II. Overhead vs. Buried Plant

Over time, overhead solutions tended to be the more cost effective solution for deploying communications and energy transmission cables. There are many reasons for this. For example, while underground facilities are not as susceptible to wind and debris-blown damage, or accidental and malicious acts, they are more susceptible to water intrusion and damage caused by floods. This makes repairs more time-consuming and costly.

Locating telecommunications cable is very important for avoiding damage and quick repair work resulting in high levels of network uptime. Overhead facility damage is easier to locate than underground and can generally be repaired in a more expedient time frame. There are some benefits to buried plant, including that service interruptions are less frequent. Unfortunately, these network outages typically last longer due to more complex repair requirements. In the instance of inclement weather such as hurricanes, areas that take the longest to repair are generally those served by underground facilities still flooded days after the storm passed. Damage and corrosion of underground systems can often show up days or even months after an event, causing additional outages and inconvenience to customers.

Severe weather, such as storm winds, can damage both types of systems causing outages. Overhead systems face outages resulting from trees and debris blowing into lines. Underground systems face outages from trees collapsing on above-ground transformers and switch boxes or from tree root systems uprooting buried cable when trees topple¹.

III. History of Phone Poles

The very beginnings of the modern telecommunications era included a major change in the structure of the first outside plant line. In 1844, Alfred Vail and Samuel Morse used their partially completed electrical telegraph to send the news of Henry Clay's nomination from Annapolis Junction, Maryland to members of Congress at the Capitol in Washington, DC. Major reliability issues existed with the physical makeup of the cable at the time of constructing that first telecommunications network. The original cotton and shellac varnish insulator cracked, resulting in numerous shorts which made the cable unreliable. This required a complete redesign of the network from a buried application to an aerial solution². The first telephones were installed in 1877, with private lines strung across rooftops. The first true telephone networks, with switchboards at a central office and poles erected along city streets began appearing after 1879. All communications cable prior to 1900 was deployed above ground in mostly aerial applications. At that time, communication poles stood as high as 90 feet tall and were described by newspapers and residents as "blackening the sky with wires". Journalists called the multiplying poles eyesores and traffic hazards.

In acts of civil disobedience, disgruntled citizens cut down telephone poles³. Telephone companies and their workers would put up new poles, sometimes using the cover of darkness, to minimize interaction with a resistant community. Local municipal governments employed organized resistance to the new communications networks as well by having fire departments cut down telephone poles. The linemen in these early years resisted by sitting atop the poles in an effort to get the fire departments to stand down⁴. This brash behavior is an echo of the type of

reckless actions that has led to so many safety related fatalities by current cell phone communications workers.

As the technology was new and mostly unknown to the average citizen, the communications cables were seen as affecting the environment. In one example, early 20th century farmers claimed the telephone and telegraph lines altered the weather⁵. In a more serious event, in 1885, a mob attacked the Montréal telephone exchange believing the telephone lines were responsible for spreading a small pox epidemic throughout Quebec⁶.

Although the above examples of telecommunications cable deployment were negative, not all communities held negative opinions of the new technologies. Some cities embraced the telephone. One example is Muncie, Indiana. At the time, the local newspaper had many positive statements about the technology. The most far sighted of these statements is when the paper is stated that the new telephone was “destined to be a great institution.” Because of this, many patrons visited the telephone exchange and sampled telephone services⁷.

These attitudes and government involvement clearly affected adoption rates of the new technology. As an example, by 1910 in Muncie, Indiana and Kingston, Ontario, two cities with similar demographics, had very significant differences in telephone use among the population, see figure 1 below. In Muncie where there was low rejection of the cables and support poles, the adoption rate of the new technology was three times higher than Kingston, Ontario where there was more resistance to the aesthetic impact of cables suspended between poles.

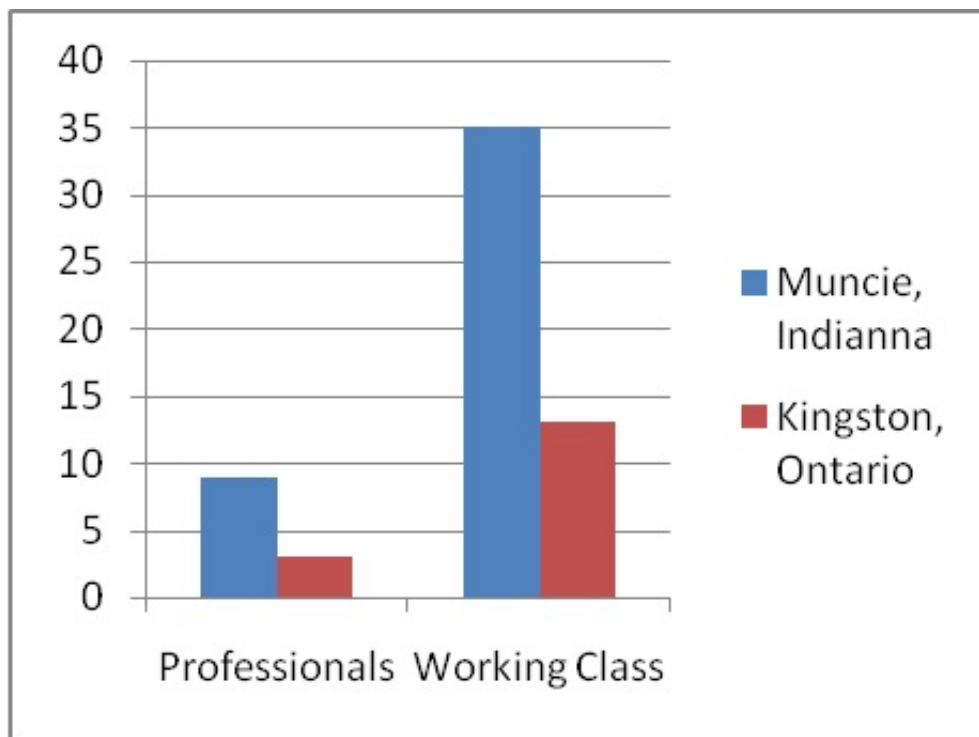

Figure 1. Percentage of Population that Adopted the Telephone in 1910.

The first workable telephone cables were placed underground in 1883, almost 40 years after the first telegraph line was placed. According to commonly believed industry lore, it has been said that the first underground cable was placed on November 5th and cut on the same day, around 4:30 p.m., on a Friday. The first cable locator was sent home for the day on the following Monday, when his manager found out about it. This is not surprising, as cable location and buried plant protection was initially seen as a job that could be given to simple minded individuals. Operators quickly realized underground plant location and protection needed a more professional mindset to avoid the costs associated with cable cuts and rework⁸.

In the late 19th century, municipalities started introducing legislation requiring all communications infrastructure to be buried underground. The actual underpinnings were more of a grab for control and revenue by local government rather than an actual desire for changing the aesthetic imprint of telephone and telegraph networks. This can be seen by the various agreements that municipalities struck with the telephone and telegraph providers at the time. In most cases, the aerial plant was allowed to remain if payments were made or if the telephone companies offered free services to local community institutions such as government offices and schools. Ultimately, it was engagement by both business and government that allowed broad and fast expansion of telephone poles and aerial plant cable⁹.

IV. Issues of Communication Aesthetics in the Modern Era

The vast majority of regulation for wire line and aerial pole infrastructure in the modern era has less to do with aesthetics and more to do with pole ‘real estate’ control. This control relates to both physical specifications and economics, including cable attachment fees for organizations that did not own the communications poles. There have been several laws at the national level in the United States, such as the Pole Attachment Act of 1978, which were designed to promote the deployment of CATV and Telecommunications¹⁰.

Challenges to this regulation went all the way to the Supreme Court with the case *Gulf Power v. the FCC*. In that case, the Supreme Court held the FCC has authority to regulate rates for pole attachment even if Internet service over cable were neither cable service nor telecommunications service¹¹.

A more recent example of communication aesthetics has to do with alternative uses of utility poles that are not related to telecommunications or energy transmission. In the State of New Jersey, there is concern over a deployment of solar panels that are connected to the smart grid. In a contract of about \$200 million with New Jersey’s Public Service Electric and Gas Company (PSE&G), Petra Solar will affix large photovoltaic solar panels to 200,000 poles in New Jersey’s six largest cities and 300 rural and suburban communities in PSE&G’s service territory¹².

Unfortunately, these attachments are creating dissent with arguments very similar to the earliest telephone and telegraph lines that were strung on phone poles in the 1870’s. They are referred to as “eyesores”, “ugly”, “hideous”, and “taking on a life of their own”. Also echoing the initial telephone line deployments are communities trying to legislate the phone poles out of their communities. There are also acts of civil disobedience related to panels disappearing off of the telephone poles¹³.

Another issue that relates to aesthetics of utility poles is a practice called “Street Spam”. Spam has become a catch all phrase for unwanted solicitations. “Street Spam” refers to illegal signs that are also called vertical litter, bandit signs, snipe signs, utility pole advertising, and stuff on a stick (SOS). For the most part, these signs rarely promote legitimate business enterprises. The signs may advertise multilevel marketing schemes, weight loss products, health insurance, sample sales, landscaping services and even pet waste removal services¹⁴.

V. Aesthetics of Transmission Infrastructure

Even in the case of buried cables, there are still some aesthetic concerns to be taken into account. Throughout any WAN network, there must be equipment to power the lines and manage the transmissions and routing. Much of this equipment is located in outside plant (OSP) cabinets. The cabinets can be located on pads, on utility poles, on walls, in vaults, or on roof tops.

Materials used are aluminum, steel, plated (galvanized) steel, and composites including polycarbonates and fiberglass. These cabinets are all designed around standards such as Telcordia GR-487, NEMA 3R or 4X, and UL ratings. Colors include: aluminum, stainless, painted white, black, RAL 7035 (light grey), and ANSI 61 (grey). One unique aspect of the wire line and wireless enclosures is that the exterior is designed around resistance to damage, usability, and thermal management. Considerations in the industry standard specifications such as GR-487 include operating at high temperatures in excess of 125° Fahrenheit, tolerance for vibrations and impacts, and resistance to mold and corrosion, see figure 2 below. Except in the situations where an underground vault is used, there is little regard to aesthetic considerations. A major reason for this is financial: Environmental concerns such as damage and temperature affect performance and usability of transmission equipment. As an example, the Mean Time Between Failure (MTBF) of communications equipment increases exponentially as the temperature decreases as shown in Figure 2.

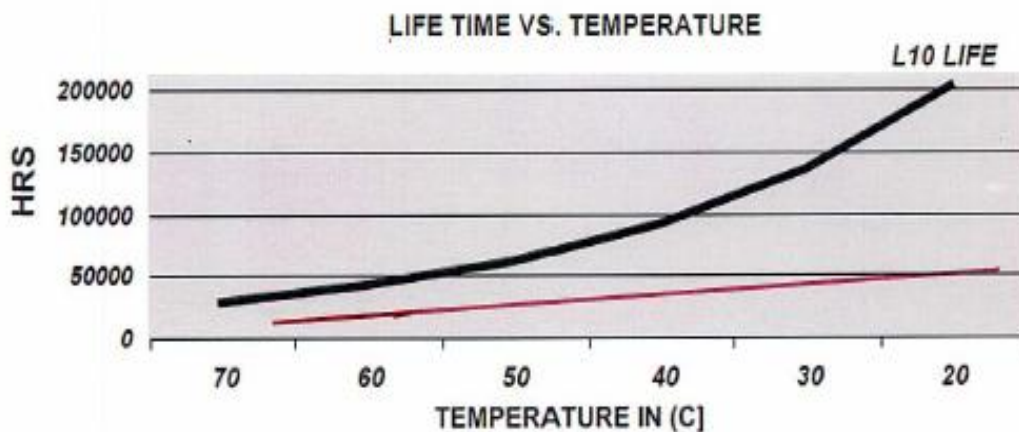

Figure 1 - Internal Temperature above Outside Ambient Air¹⁵

The different materials used will directly affect temperature. One test by Pentair Technical products shows how the different types of materials and colors dramatically affect the

temperatures inside the tested enclosures, see figure 3 below. Of interesting note is how dramatically all the enclosures dipped at approximately 1:30pm when clouds moved in and wind speed increased. This tells us that no matter the material used, the environment plays a very large role on the internal operating temperatures of the enclosures.

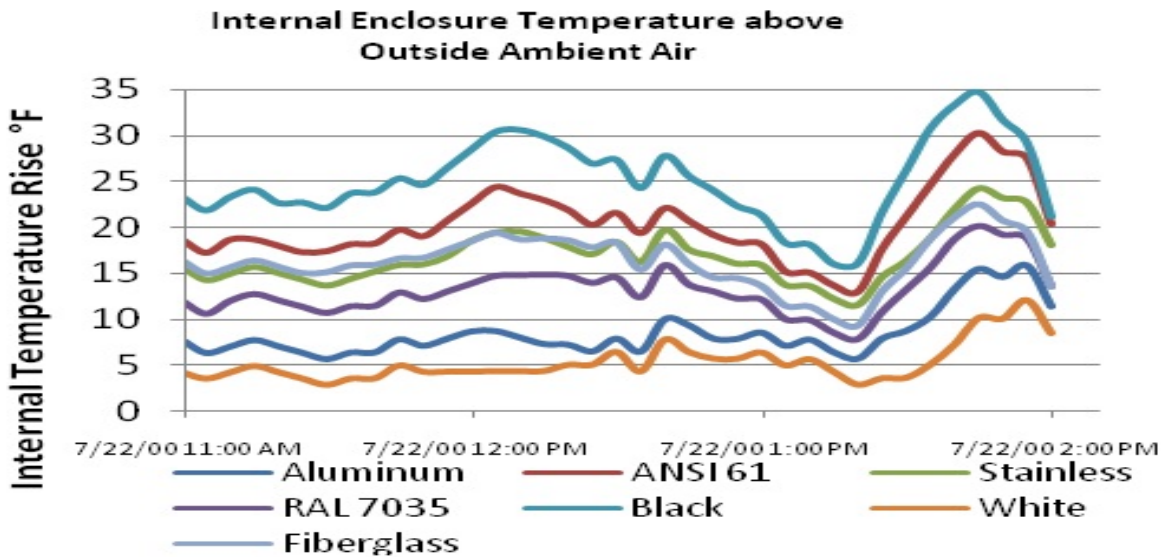

Figure 3 - Internal Temperature above Outside Ambient Air¹⁵

VI. Aesthetics of Wireless

In the same way that there are distinct advantages and disadvantages between wire line and wireless networks, there are also distinct differences in the aesthetic concerns of the wireless networks. Although wireless networks use enclosure types similar to wire line networks, the most noticeable difference is the use of large towers and antenna arrays in wireless transmissions. There are several different cell tower styles, and there is more concern placed on cell tower placement and appearance by communities.

There are four different types of towers. The first tower is known as a Lattice Tower, and it is also referred as a Self-Support Tower (SST). The lattice tower affords the greatest flexibility and is often used in heavy loading conditions. A lattice tower is typically three sided and has a triangular base. The second type of tower is known as a Monopole Tower. A monopole tower is exactly what its name implies: it is a single tube tower. Monopole towers typically do not exceed 200 feet in height. The antennas are mounted on the exterior of the tower. The third type of tower is a Guyed Tower. Guyed towers are straight towers supported by guy wires anchoring the tower. They tend to be the least expensive tower to construct, but by design they require a large amount of land. These towers can reach heights of 300 feet tall and greater.

There is one type of tower that is specifically designed for aesthetic concerns. It's called a Stealth Tower, and typically is installed only where community standards or zoning requires them to be installed. In most cases these towers require additional material to "Stealth" their appearance which increases the cost to build the towers. Examples include trees, church steeples,

flag poles, inside store signs, false floors on multi-story buildings, false chimneys, fake water towers, inside grain silos or completely fake grain silos¹⁶. These additional costs are one reason why carriers tend not to deploy stealth towers unless required to do so. Another reason is because the unique designs of these towers fail to provide the same amount of capacity for tenants that are provided by the guyed, monopole, and lattice tower types.

A final area of wireless tower aesthetics relates to the ground level equipment. Transmitters for the antennas affixed to the towers are usually located in cabinets or in shelters. The wireless cabinets are generally built to the same specifications as the wire line cabinets. The shelters are small single-room buildings and sometimes referred to as Base Transmitter Stations (BTS). The BTS buildings are pre-manufactured and little is done to design them with aesthetics in mind.

Other ground level equipment includes utilities that run to the tower to power and provide backbone communication services. This means that every cell tower generally has to deal with aesthetics of wire line communications as usually there are many wire lines running to each cell tower location.

VII. Conclusions

Color, style, and placement of communications equipment in the outside plant are all areas of aesthetic interest. These elements affect both fixed line transmission systems as well as wireless transmission equipment. These elements also can affect the performance and lifetime of telecommunications transmission equipment.

Current regulation and socio-political trends are mirroring the past when it comes to communications infrastructure and aesthetics. It can be concluded that any significant change in communications infrastructure will garner attention from residents of the communities served by that infrastructure. If these changes or enhancements are deemed as negative, there will be resistance from those that are affected by the change. Technologies and processes exist that can make outside plant communications infrastructure more transparent, but these types of approaches generally tend to cost service providers more with minimal economic benefit to the corporate bottom line.

VIII. Future Work

More research can be done in the different methodologies that can be employed to integrate base stations and outside plant cabinets into their environment. More study can be done to determine materials that can be used that to provide similar or enhanced performance benefits, yet be stealthier in appearance. An associated area of future work could be a cost analysis of existing materials verses materials and equipment that is both more aesthetically appealing in the environment and maintains or improves equipment performance.

A second area of study could be an analysis and comparison of international, national, state, regional and local regulation for aesthetic elements of cellular towers. An additional investigation on what types of cost savings can be achieved via economies of scale if stealth

towers were regulated to be the standard versus the current approach of using stealth towers only in areas where they are explicitly called for.

IX. References

- [1] Florida Power and Light, "Underground FAQ," [Online]. Available: <http://www.fpl.com/faqs/underground.shtml>. [Accessed 10 6 2012].
- [2] S. Vail, "Alfred Vail was Morses Partner," The New York Times, May 1894.
- [3] "Telegraph Poles Cut Down," The New York Times, p. 9, 4 November 1883.
- [4] "An Inside View of the Telephone Business," Indianapolis Daily Sentinel, p. 4, 8 April 1886.
- [5] "Wiggin's Great Discovery: Wire Fences and Telephone Lines Cause Droughts," The New York Times, p. 17, 21 June 1891.
- [6] W. G. Patten, *Pioneering the telephone in Canada*, Montreal: Privately Printed, 1926.
- [7] Muncie Daily News, p. 1, 4 March 1880.
- [8] D. McCarthy, "Underground Cable Locating - Yesterday and Today," OSP Magazine. , 2009.
- [9] R. MacDougall, "The Telephone on Main Street: Utility Regulation in the United States and Canada before 1900," *Business and Economic History Online* , vol. 4, 2006.
- [10] Law Offices of Michael L. Glaser L.L.C, "U.S. Supreme Court Upholds Fcc's Right To Set Pole Attachment Fees," 6 8 2012. [Online]. Available: <http://www.telecomattorneys.com/poleattachmentfees.html>. [Accessed 6 8 2012].
- [11] *Gulf Power Co. v. FCC*, 2000.
- [12] Noria Corporation, "Petra Solar inks \$200M solar installation contract with PSE&G," *Reliable Plant*, 15 11 2011.
- [13] M. Navarro, "Solar Panels Rise Pole by Pole, Followed by Gasps of 'Eyesore'," The New York Times, 27 April 2011.
- [14] CAUSS.ORG, "CAUSS FAQ about Street Spam," [Online]. Available: <http://www.causs.org/faq.html>. [Accessed 11 6 2012].
- [15] B. Mordick, "Pentair technical products presentation to BICSI," Pentair Technical Products, Raleigh, NC , 2012.

[16] J. Pisani, "<http://images.businessweek.com/ss/06/08/tower/source/1.htm>," BusinessWeek, [Online]. Available: <http://images.businessweek.com/ss/06/08/tower/source/1.htm>.

Biography:

Dr. Ibraheem Kateeb is the section chair of Central NC section and a Senior Member of IEEE with over 25 years of experience in academia and industry. He received his Ph.D. from NCA&TSU. He is currently at NCA&TSU as Assistant Professor of Computer Systems Technology Department. His current research is on power and green energy, electronics and control/robotics. In the last two years, he published more than 27 journal and conference papers and has many projects and grants in power, renewable energy and smart grid related issues. Dr. Kateeb was recognized as the recipient of Academic Excellent Award from CARTS International 2012 (Electronic Components Industry Association, ECIA) for one of his research papers.

Khaled F AIotaibi is currently a PhD candidate at North Carolina Agricultural and Technical State University USA. He received his B.S. in Electrical and Computer Engineering from King Abdulaziz University, Saudi Arabia in 2005, M.S. from North Carolina Agricultural and Technical State University, USA in Computer Science Software Engineering in 2009. His research interest is in the application of the control to power system.

Michael S. Peluso received his MS from the Computer Systems Technology at NCA&TSU, he is an adjunct instructor at a community college in NC, and a Ph.D. student at A&M State University.

Dr. Larry Burton received his BS, MS, and Ph.D. in electrical engineering from Duke University. He has 25 years executive international management experience in technology-based businesses, and holds ten patents in microwave and optical communications, video switching, and broadband infrastructure. His current research is focused on high availability / high reliability enterprise computing.

Dr. Evelyn R. Sowell has been an adjunct assistant professor of Information Technology in the Computer Systems Technology department at North Carolina A&T State University's School of Technology since 2009. Dr. Sowell has earned a Ph.D. in Electrical and Computer Engineering from North Carolina A&T State University's College of Engineering. She also holds a M.S. and B.S in Computer Science with a concentration in software engineering. Her primary research interests are low-power high performance, asynchronous and self-timed digital system design, particularly, the development of power aware algorithms and techniques for system timing optimizations. Specific interests include portable digital electronics and high performance computation. Evelyn is also a member of Upsilon Phi Epsilon, Computer Science Honor Society.

**A Community College Perspective
of the
Development of Engineering Transfer Model Curricula
under the
California Student Transfer Achievement Reform Act (SB 1440):
An Update on Work in Progress**

**Kate Disney, Erik Dunmire, Michelle Millea,
Larry Owens, Jo-Ann Panzardi, Liz Rozell
Mission College/College of Marin/Ventura College/
College of the Sequoias/Cabrillo College/Bakersfield College**

Abstract

California Senate Bill 1440, The Student Transfer Achievement Reform Act, requires California Community Colleges (CCCs) to develop associate degrees for transfer to the California State University (CSU) system. Engineering faculty representatives from both systems have worked together to develop preliminary transfer model curricula and associated course descriptors. Both the model curricula and the course descriptors are currently undergoing statewide vetting at the writing of this paper. The results of the vetting process and up-to-date documents will be presented.

Legislation

California Senate Bill 1440, The Student Transfer Achievement Reform Act¹, requires California Community Colleges (CCCs) to develop associate degrees for transfer to the California State University (CSU) system. The CSUs are required to prepare to accept students who complete these AA-T or AS-T degrees. The intent is to develop a more uniform and streamlined transfer process from the CCC to the CSU.

Under SB1440, an associate degree for transfer must include 60 transferable semester units (90 quarter units), including lower division general education and at least 18 semester units in a major or area of emphasis. Students completing an AA-T or AS-T and accepted at a CSU campus are to be admitted with “junior status” and shall not be required to complete more than an additional 60 semester units (90 quarter units) for majors requiring 120 or 180 units, respectively. High-unit majors, such as engineering, are exempt from this CSU-level requirement. The unit requirements pose a challenge in creating an engineering AS-T degree. It should be noted that that CSU engineering programs are currently under pressure to bring their bachelor’s degree programs down to a maximum of 120 semester or 180 quarter units. This requirement may significantly affect the transfer curriculum process.

Curriculum Development

CCC and CSU engineering faculty representatives have been meeting to develop transfer model curricula (TMC) and course descriptors for engineering (see Course Identification Numbering System website²). It was decided early in the process that preparation for the major is the priority of any transfer curriculum and the 60-unit cap on lower division units could not be met if both major preparation and lower division general education (GE) were to be completed prior to transfer. Therefore, in the spirit of SB1440, two model curricula and the associated course descriptors (C-IDs) were developed – one for Electrical/Computer Engineering (EE/CompE) and one for Mechanical, Civil, Aerospace, and Manufacturing Engineering (ME/CE) to maximize the overlap of course requirements in those disciplines, respectively. Additional model curricula, such as Chemical or Biomedical Engineering, may be developed in the future.

The two model curricula that were developed take two different routes. Both curricula include the typical support courses of calculus, physics, and chemistry. The EE/CompE model curriculum (Table 1) emphasizes the completion of as much lower division GE as possible with just a few engineering courses in the lower division. There was much discussion among the committee members regarding this, but a consensus to add additional engineering courses was not reached.

Table 1 Draft Model Curriculum Electrical and Computer Engineering 11/9/2012 Version	
Course Title	Semester Units (minimum)
Required Engineering Core Courses	7
Introduction to Engineering	1
Circuit Analysis	3
Introduction to Programming Concepts and Methodologies for Engineers	3
Required Science Courses	13
Calculus-based Physics A (Mechanics)	4
Calculus-based Physics B (E & M)	4
General Chemistry with Lab	5
Required Math Courses	15
Calculus I	4
Calculus II	4
Multivariable Calculus	4
Ordinary Differential Equations	3
Total Units (minimum)	35

The ME/CE model curriculum (Table 2) emphasizes the completion of as many lower division engineering courses as possible. The difference between these two approaches is in most part due to the more standardized curriculum in ME/CE programs compared to EE/CompE programs. CSU EE/CompE programs have a greater variety of specialized lower division courses from campus to campus, which makes it difficult to duplicate in a community college engineering program.

Table 1 Draft Model Curriculum Mechanical, Civil, Aeronautical, or Manufacturing Engineering 11/9/2012 Version	
Course Title	Semester Units (minimum)
Required Engineering Core Courses	23
Introduction to Engineering	1
Engineering Graphics	3
Statics	3
Materials Science and Engineering	4
Introduction to Programming Concepts and Methodologies for Engineers	3
Circuit Analysis	3
Strength of Materials	3
Dynamics	3
Surveying (recommended for CE if available)	3
Note: Two of the above courses must contain a lab.	
Required Science Courses	13
Calculus-based Physics A (Mechanics)	4
Calculus-based Physics B (E & M)	4
General Chemistry with Lab	5
Required Math Courses	15
Calculus I	4
Calculus II	4
Multivariable Calculus	4
Ordinary Differential Equations	3
Total Units (minimum)	51

With the addition of lower division GE to either pattern, the total units upon transfer would be greater than the 60 units specified in SB 1440. Hence, these are being called “Model

Curriculum” rather than the official “Transfer Model Curriculum” (or TMC). Approval of these model curricula will require a waiver of the 60-unit lower division requirement.

The two model curricula which were developed and are summarized in the above tables are currently in the statewide vetting process³. The vetting process allows for review and comment by any interested parties. The results of that process and any progress in developing the curricula subsequent to the vetting will be presented.

Conclusion

The purpose of SB 1440 is to streamline and simplify the transfer of students from California community colleges to the California State University system. Creating an engineering transfer curriculum to meet the requirements of the law is difficult due to the high-unit nature of the engineering major, which requires a great many lower division preparation and support courses. In the spirit of SB 1440, two model engineering curricula have been drafted by a committee composed of both CCC and CSU faculty, and are being reviewed statewide at this time. With constructive input, serious discussions and compromise from both institutions, a workable transfer pattern may eventually result from this process, benefitting both institutions and the engineering students that transfer between them.

Bibliography

1. Padilla. "Senate Bill SB 1440." *Senate Bill SB 1440*. California State Senate, 29 Sept. 2010. Web. 22 Mar. 2013. http://www.leginfo.ca.gov/pub/09-10/bill/sen/sb_1401-1450/sb_1440_bill_20100929_chaptered.html
2. Course Identification Numbering System, California Community College Chancellor's Office, <http://www.c-id.net/>
3. *ibid.*, <http://www.c-id.net/degreereview.html>

A Data-Driven Approach to Categorizing the Spatial Organization of Homework Solutions

J. Herold, A. Zundel, and T. F. Stahovich
University of California, Riverside

Abstract

It has been shown in prior work that both the temporal and spatial organization of a student's solution to a homework or exam problem correlates with his or her performance on that solution. This result supports the intuition that the way in which a student organizes his or her work provides a view into the cognitive processes by which that student solved that problem.

In the present work, we seek to develop taxonomy for the organization exhibited by students. The categories we identify serve as a basis for examining the cognitive processes employed by students as they solve homework problems. We employ a data-driven approach to automatically construct this taxonomy. This approach is enabled by our unique database of coursework. In the winter of 2012, undergraduate Mechanical Engineering students enrolled in a Statics course were given Livescribe™ digital pens. The students completed their homework assignments with these pens, creating a digital corpus of all their work in the form of time-stamped pen strokes.

To capture the spatial organization exhibited by the students, we represent each page of a solution as a low-resolution image bitmap. We compute distances between bitmaps and group them by that distance using the K-Means clustering algorithm. Each of these groups represents a distinct spatial organization behavior. We manually examine the handwritten solutions comprising these groups, and describe the higher-level organizational habits they exhibit. From these habits, we gain insights into the cognitive processes employed by students as they solve homework problems.

Introduction

It has been shown in prior work that both the temporal and spatial organization of a student's solution to a homework or exam problem correlates with his or her performance on that solution. This result supports the intuition that the way in which a student organizes his or her work provides a view into the cognitive processes by which that student solved that problem.

In the present work, we seek to develop taxonomy for the organization exhibited by students. The organizational categories we identify serve as a basis for examining the cognitive processes employed by students as they solve homework problems. While we could manually inspect student work to identify typical organizational patterns, such an approach is prohibitively time-consuming. Also, the results may be subject to coder-bias as they rely on a particular inspector's

judgment. Instead, we employ a data-driven approach to automatically discover patterns latent in the organization of students' work.

This data-driven approach is enabled by our unique database of coursework. In the winter of 2012, undergraduate Mechanical Engineering students enrolled in a Statics course were given Livescribe™ digital pens. The students completed their homework assignments with these pens, creating a digital record of all their work in the form of time-stamped pen strokes.

To capture the spatial organization exhibited by the students, we represent each page of a solution as a low-resolution bitmap. This process removes small variations in the students' solutions, capturing a general representation of the layout of the ink on a page. We may then compute the distance between two bitmaps using the Hausdorff distance, a popular bitmap distance metric. Having a distance metric for bitmaps allows us to cluster them using the K-Means³ clustering algorithm. This algorithm identifies groupings of bitmaps that are more similar with one another than with the bitmaps of other groups. Each of these groups represents a distinct spatial organization type. We then manually examine the pages which comprise each grouping, and describe the high-level organizational habits that are present. From these habits, we gain insights into the cognitive processes employed by students as they solve homework problems.

Related Work

In the present research, we apply Educational Data Mining techniques to identify correlations in students' work in a data-driven way. Educational Data Mining is a nascent research field in which Data Mining techniques are applied to educational data in order to make discoveries about how students learn. Recent work in this field has typically focused on data extracted from either Learning Content Management Systems (LCMS) or intelligent tutoring systems (ITS). For example, Kinnebrew and Biswas³ examined students' interactions with the Betty's Brain ITS. This system logged the actions students took while working with it. Sequence mining techniques were then applied to identify series of actions that correspond to productive and unproductive learning behaviors. Romero et al.⁶ applied Data Mining techniques to data collected with the Moodle LCMS which records detailed logs of students' interactions, such as viewing and submitting assignments. These logs were mined for rare association rules describing patterns that appear infrequently in the data. The resulting rules were then manually inspected to identify fringe behaviors exhibited by students.

Oviatt et al.⁵ examined computer interfaces for completing geometry problems and found that "as the interfaces departed more from familiar work practice..., students would experience greater cognitive load such that performance would deteriorate in speed, attentional focus, meta-cognitive control, correctness of problem solutions, and memory." Thus it is important for Educational Data Mining to be applied to data collected under ordinary work conditions.

Van Arsdale and Stahovich⁷ have demonstrated a correlation between the temporal and spatial organization of a student's handwritten exam solutions and the correctness of the work. The work was captured with digital pens. The organization was characterized by a set of quantitative features computed from the digitally recorded ink. On average these features accounted for 40.0% of the variance in students' performance. Similarly, Herold and Stahovich² applied Data Mining techniques to identify how self-explanation affected students' problem solving processes. The study included an experimental group which provided handwritten self-explanation for the major steps in each homework solution, and a control group which did not. Digital copies of the students' handwritten homework were mined for commonly occurring patterns, revealing that students who generated self-explanation solved problems more like an expert than those who did not. In this work, we employ similar, data-driven techniques to identify correlations between students' homework effort and performance.

Our work continues with this trend of applying Educational Informatics to data collected under familiar work practice. We build on the research of Van Arsdale and Stahovich by further examining the organizational habits of students' handwritten homework solutions. While this work has shown that a correlation exists between students' organization and performance, it does not investigate what archetypical behaviors are exhibited by students. Our work focuses on developing profiles of students' organizational habits using unsupervised machine learning methods and not necessarily on automatically predicting students' performance based on their organizational habits.

Data Collection

In the winter quarter of 2012, over 120 students enrolled in an undergraduate Mechanical Engineering course on Statics were given LiveScribe™ digital pens which they used to complete their coursework. This produced a digital, time-stamped record of every student's homework, quizzes, midterms, and exams. In total, we collected data from six homework assignments, seven quizzes, two midterms, and the final exam.

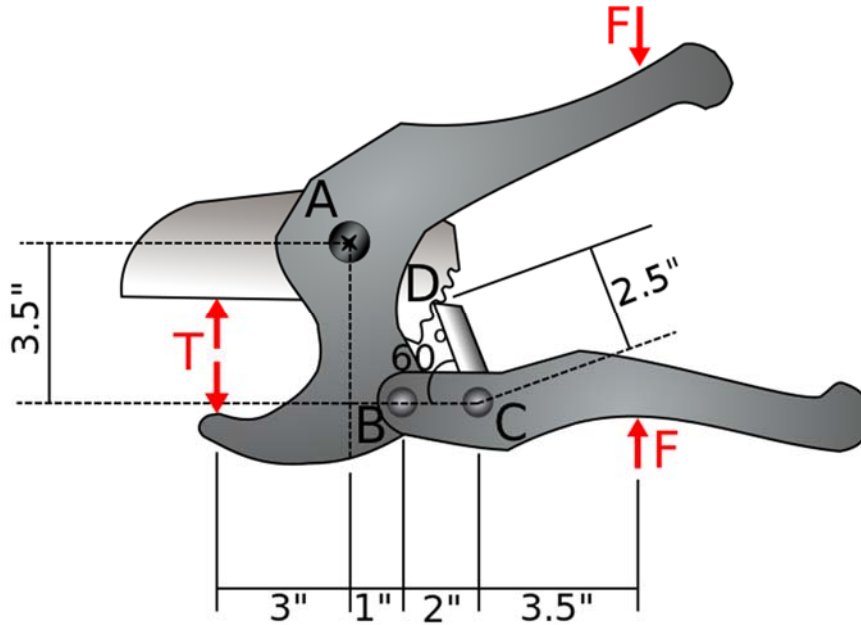

Figure 1: Typical problem from the Statics course. The problem statement reads as follows, “The device shown is used for cutting PVC pipe. If a force, $F = 15$ lb., is applied to each handle as shown, determine the cutting force T . Also, determine the magnitude and the direction of the force that the pivot at A applies to the blade.”

An example of a typical exercise problem from the Statics class is provided in Figure 1. Problems typically required students to identify resultant forces acting on a system. Two examples of typical solutions to the problem shown in Figure 1 are presented in Figure 2. In solving these problems, students typically draw a free body diagram (FBD), construct equilibrium equations describing the sum of the moments as well as forces in the x- and, y-direction, and then solve those equations, yielding the value of the unknown resultant forces. Students’ solutions to a given problem can vary greatly from one another. For instance, the left portion of Figure 2 shows a solution to the problem shown in Figure 1 that follows a strict and neat spatial organization; each FBD component is directly followed by all equations that refer to it, clearly showing the solution steps the student followed to reach his or her final answer. The second solution instead lacks strict spatial organization, reflecting perhaps, a poor mastery of the subject matter; there are several FBD components, several which are redrawn, and the equations are written in a disorderly fashion.

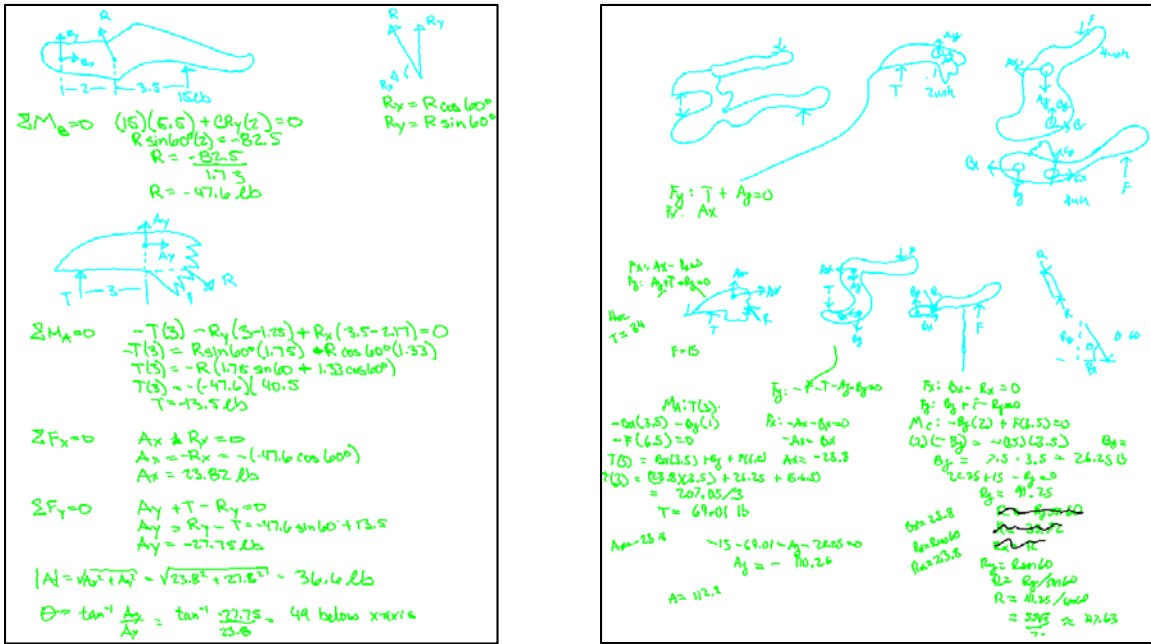

Figure 2: Example of typical student work. The image to the left is an example of neatly organized work while the image to the right is an example of less organized work. Ink color denotes the semantic content of the ink. Green indicates an equation pen stroke, blue indicates a FBD pen stroke, and black indicates a cross-out pen stroke. The LiveScribe™ pens used ink and thus students were required to cross-out any unintended writing.

In the present work, we analyze students' solutions to the final exam. This test comprised nine questions and covered all concepts covered throughout the course. The first problem of the exam was an ethics question. The expected answer to this problem was different from that of the other problems as it required a simple, one-sentence answer. For that reason, the first problem of the exam is not included in the analysis that follows.

Solution Bitmaps

Our approach begins by converting each handwritten solution into two binary images: one containing ink for all FBDs and one for all equations. Figure 4 shows an example of a student's solution and the resulting two FBD and equation bitmaps.

To construct a solution bitmap, first a minimum bounding box is constructed around the entire solution. This box is divided into a 10 x 10 bitmap. Each pixel in the bitmap is then marked with a value of either '1' or '0', indicating whether any ink exists in that pixel or not respectively.

This produces a coarse-grained representation of the students' work as it is effectively a down-sampling of the original sketch. This representation naturally removes minute variances between students' solutions and instead captures the general organization present in each solution.

Clustering

We perform eight separate clustering processes, one for each problem on the final exam. In each process, all pages of solutions corresponding to the same final exam problem number are used as input to the K-Means clustering algorithm.

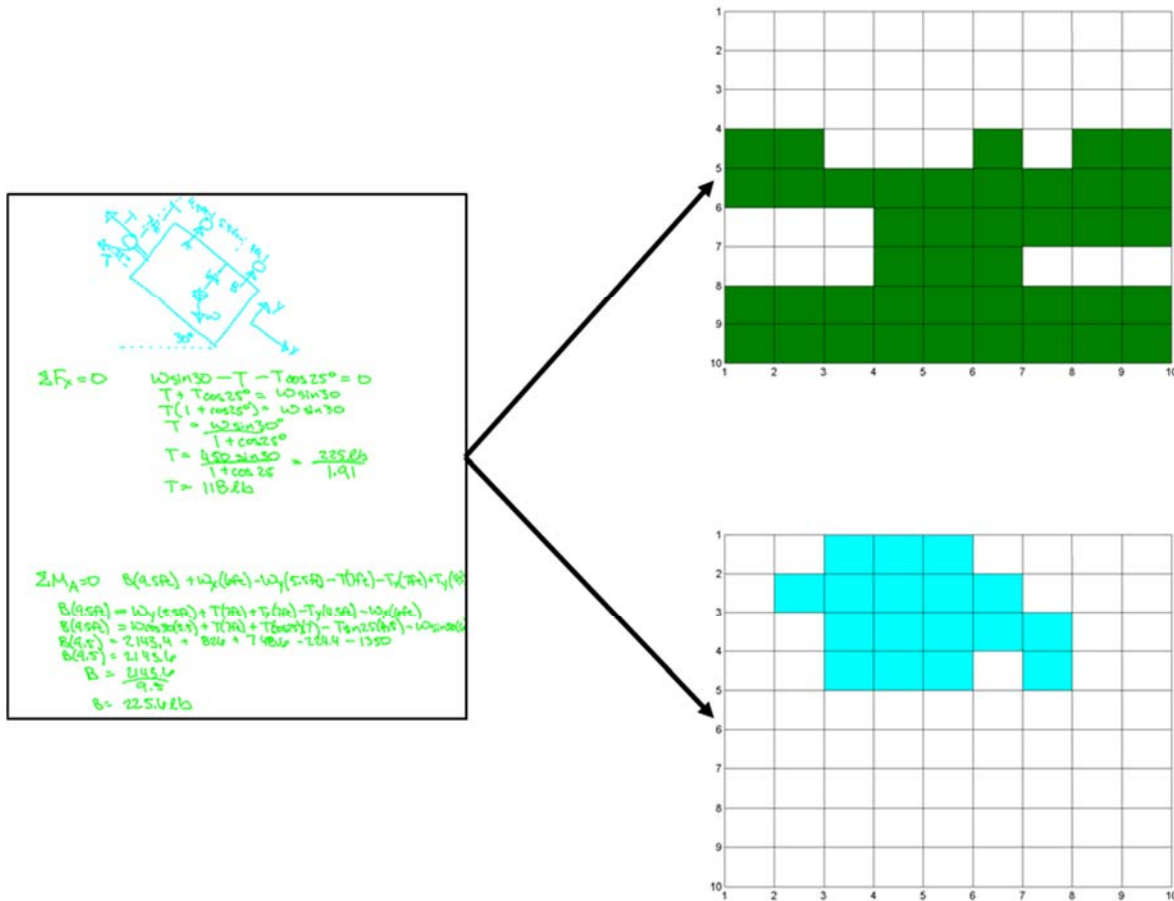

Figure 4: Example of a student's handwritten solution (left) and resulting equation (green) and FBD (blue) bitmap.

The clustering algorithm employs the Hausdorff distance to measure the similarity between two sets. The Hausdorff distance between two bitmaps is defined as:

$$H(A, B) = \max(h(A, B), h(B, A))$$

where:

$$h(A, B) = \max_{a \in A} (\min_{b \in B} (\text{distance}(a, b)))$$

is called the directed Hausdorff distance. Note that $h(A, B) \neq h(B, A)$. Here, *distance* is the Manhattan distance between two bitmap pixels *a* and *b*. Intuitively, the Hausdorff distance

identifies the distance, d , such that each pixel in A is at most d from some pixel in B , providing a general measure of similarity between bitmaps A and B .

The K-Means clustering algorithm is used to optimally group n objects into k clusters, such that each object within a cluster is closer to the mean of all objects in that cluster than the mean of objects in any other cluster. Here, the objects being clustered are the solution bitmaps, and the distance between bitmaps is defined using the Hasudorff distance. The number of clusters, k , must be selected *a priori*. We use a value of $k = 9$ for each run of the clustering algorithm. This value proves to be sufficiently high for the data we have collected. We use the K-Means implementation of the WEKA¹ data mining software suite.

Group Analysis

Presenting the clustering results for each grouping for each problem would prove to be intractably large. Instead we present in this section a manual analysis of the results of clustering the FBD solution bitmaps from final exam problem two and six and discuss the high-level behaviors exhibited by the typical solutions of each group. The results for these problems are sufficient to characterize the types of conclusions that can be drawn using our unsupervised analysis.

While we used a cluster value, k , of nine, it is not always the case that the algorithm will identify nine meaningful groups. In some cases, there were less than nine groupings present in the data and thus some groups are empty, that is, they contain no solution bitmaps.

For problem two, the K-Means algorithm identified three non-empty groups. The first group comprised 24 sketches. The FBDs of the sketches within the first group typically were small in comparison to FBDs of other groups. Furthermore, these FBDs typically depicted a single element comprising an outline of the entire system shown in the problem description image. Three typical solution bitmaps from this group are shown in Figure 5. This grouping characterizes solutions' by students who are having difficulty solving the problem and are unable to divide the system into components which allow the unknown forces to be solved.

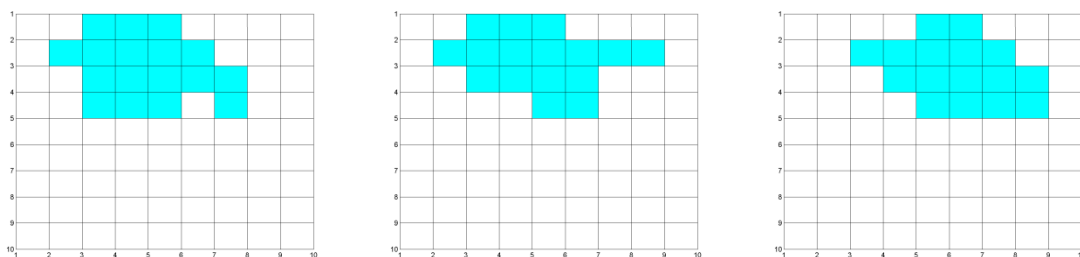

Figure 5: Typical solution bitmaps from group one of problem two.

The second group comprised 92 sketches. The FBDs of the sketches within this group typically spanned the entire page and were often either a single large FBD outlining the entire problem

description image or comprised several small components scattered across the entire page. This group is characterized by solutions written by students who perhaps were struggling to identify the FBD that would best lead to the correct solution, and spent an entire page testing different FBDs until they came across an acceptable one. Three typical bitmaps from this group are shown in Figure 6.

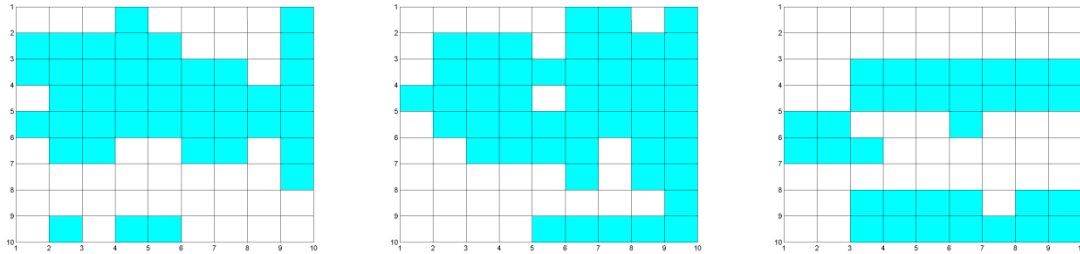

Figure 6: *Typical solution bitmaps from group two of problem two.*

Lastly, the third group comprised 24 sketches. Sketches from this group typically contained the same FBD component redrawn at least once. This group is characterized by students who made mistakes in their first FBD and had to later start over, perhaps indicating a lack of understanding. Three typical bitmaps from this group are shown in Figure 7.

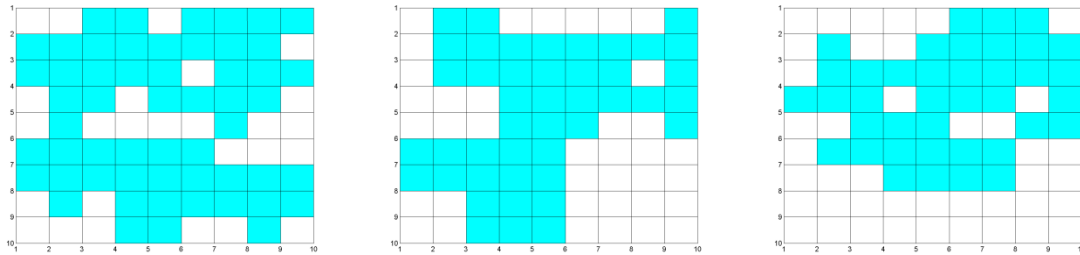

Figure 7: *Typical solution bitmaps from group three of problem two.*

For problem six, the K-Means clustering algorithm identified five non-empty groups. The first group comprised 18 sketches, all of which came from the second page of a solution to a problem. Sketches in this group typically contained a single, small FBD in the upper left corner of the page, representing the two-force-member present in that problem. This grouping is characterized by solutions of students who saved solving the two-force-member as the final step. Three typical bitmaps from this group are shown in Figure 8.

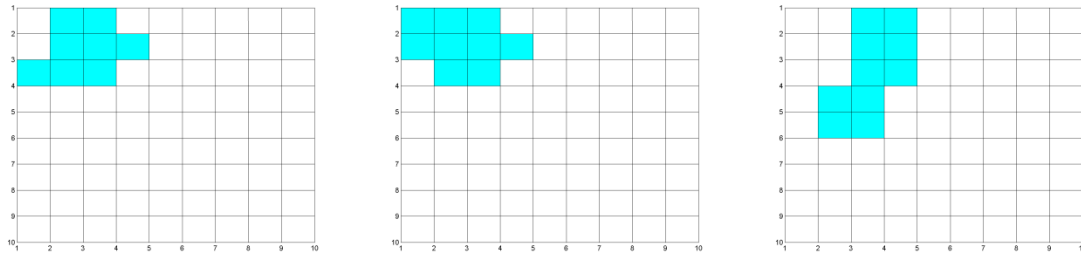

Figure 8: Typical solution bitmaps from group one of problem six.

The second group comprised 42 sketches. These sketches typically contained a single, large FBD which was simply an outline of the entire system shown in the problem description image. This group is characterized by a lack of understanding by students, as they were unable to identify proper boundaries which exposed the forces required to solve for the unknowns. Three typical bitmaps from this group are shown in Figure 9.

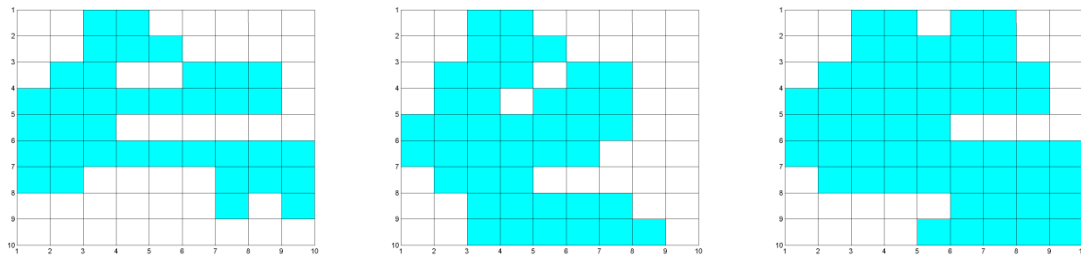

Figure 9: Typical solution bitmaps from group two of problem six.

The third group comprised 19 sketches. These sketches typically contained just two FBDs that horizontally spanned the top of the page. This group is characterized by students who completely finished their FBDs prior to beginning work on the equations. Three typical images of solutions from this group are shown in Figure 10.

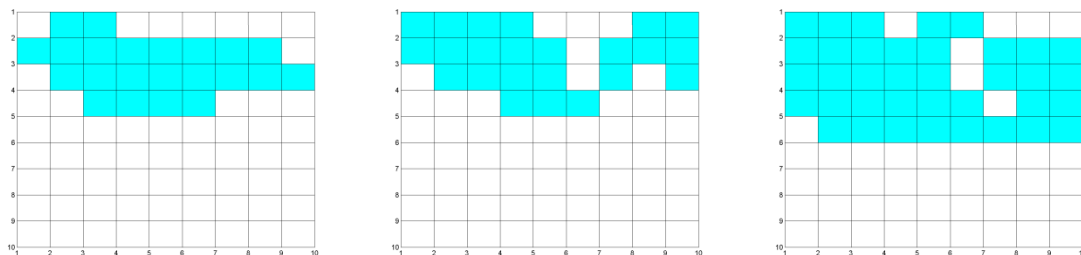

Figure 10: Typical solution bitmaps from group three of problem six.

Groups four, five, and six are very similar and comprise 39, 47, and 8 sketches respectively. Each of these groups typically contains three to four FBDs spread out vertically along the left margin of the page. These groups are characterized by students who drew a single component of the FBD, solved equilibrium equations for that component, then moved on to the next component, and so forth. Three typical bitmaps from this group are shown in Figure 11.

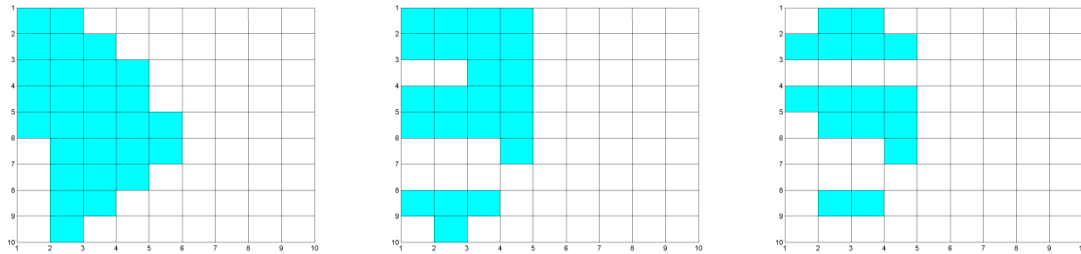

Figure 11: Typical solution bitmaps from groups four, five, and six of problem six.

Discussion

It is important to note that the results presented in the previous section concern typical templates from each grouping and are not a generalization that necessarily applies to every template in a single grouping. We strove to manually identify common themes present in many of the templates but which may not hold true for all templates in that group.

Furthermore, the clustering results do not directly reflect the quality or content of the FBDs or equations written by the students. For example, two FBDs of similar shape, size, and location, drawn by two different students, would be grouped together by this algorithm, even if those FBDs corresponded to solutions of a student who did and did not perform well.

Instead, these clusters identify different organizational behaviors exhibited by students. Using these clusters, we identified the common, high-level organizational patterns exhibited by the students via a manual inspection of the actual solutions. While it has been shown in previous work that students' organizational habits are indicative of their performance, the goal of this work is not to automatically identify students' performance given the organization of their FBD and equation writing, but instead to develop a taxonomy of the types of behaviors exhibited by students as they solve problems. By better understanding the typical behaviors students employ when solving Statics problems, instructors may gain insights into the cognitive processes employed by students.

This work paves the way for future work to analyze the performance of students who exhibit particular organizational patterns to see if there is a significant correlation between the types of organization employed and performance.

Conclusion

In this work, we have taken first steps in developing taxonomy for the types of organization exhibited by students. We applied educational informatics techniques to automatically identify groupings of students who organized their solutions in a similar way. These techniques are enabled by our unique database of coursework. In the winter of 2012, undergraduate Mechanical Engineering students enrolled in a Statics course were given Livescribe™ digital pens. The

students completed their homework assignments with these pens, creating a digital record of all their work in the form of time-stamped pen strokes.

We represent each page of a solution as a low-resolution bitmap. We compute distances between bitmaps using the Hausdorff distance and cluster the bitmaps by that distance using the K-Means clustering algorithm. This algorithm identifies groupings of bitmaps that are similar with one another and distinct from bitmaps of other groups. Each of these groups represents a distinct spatial organization type. Having examined the pages which comprise each grouping, we were able to describe the higher-level organizational habits exhibited by the students. These habits have important pedagogical implications for instructors. Furthermore, the techniques presented here serve as a good basis for future systems which may process students' handwritten, digital solutions and automatically identify deficiencies in students' understanding.

Acknowledgements

The authors gratefully acknowledge support for this work provided by the National Science Foundation via award No. 0935239.

Bibliography

1. Hall, M., Frank, E., Holmes, G., Pfahringer, B., Reutemann, P., Witten, I. The WEKA Data Mining Software: An Update. In *SIGKDD Explorations* 11, 1, 2009.
2. Herold, J. and Stahovich, T. Characterizing Students' Handwritten Self-Explanations. In *Proceedings of American Society for Engineering Education Annual Conference & Exposition*, 2012.
3. Kinnebrew, J. and Biswas, G. Identifying Learning Behaviors by Contextualizing Differential Sequence Mining with Action Features and Performance Evolution. In *Proceedings of the Fifth International Conference on Educational Data Mining*, 2012.
4. MacQueen, J., Some Methods for Classification and Analysis of Multivariate Observations. In *Proceedings of the Fifth Berkeley Symposium on Mathematical Statistics and Probability*, 281-297, 1967
5. Oviatt, S., Arthur, A., and Cohen, J. Quiet interfaces that help students think. In *Proceedings of the 19th annual ACM symposium on User interface software and technology*, 191–200, 2006.
6. Romero, C., Romero, J., Luna, J., and Ventura S. Mining Rare Association Rules from e-Learning Data. In *Proceedings of the Third International Conference on Educational Data Mining*, 2010.
7. Van Arsdale, T. and Stahovich, T. Does Neatness Count? What the Organization of Student Work Says About Understanding. In *Proceedings of American Society for Engineering Education Annual Conference & Exposition*, 2012.

Using a Lexical and Temporal Analysis of Students' Self-Explanation to Predict Understanding

Nicholas M. Rhodes¹, Matthew A. Ung², Jim Herold¹, Thomas F. Stahovich²

¹Department of Computer Science, University of California Riverside

²Department of Mechanical Engineering, University of California Riverside

Abstract

Numerous studies have shown that self-explanation can lead to increased learning outcomes. Here we examine how the quality of self-explanation correlates with performance. More specifically, we examine how the words students use in their self-explanations correlate with performance on homework. We also examine how the time spent solving problems and writing self-explanations correlates with performance. We conducted a study in which 30 students in an undergraduate Mechanical Engineering Statics course provided handwritten self-explanations of the major steps in each of their homework problems. The students completed the homework and self-explanations using Livescribe™ Smartpens. These devices record the work as time-stamped pen strokes, enabling us to see not only the final ink on the page, but also the order in which it was written. Our analysis relies on data mining techniques—specifically K-Means clustering and Correlation Feature Selection—to find patterns of language and timing that correlate with performance. For example, we use K-Means clustering to identify which vocabulary choices indicate a strong understanding of the material and which choices indicate poor understanding. We also consider how the temporal properties of the self-explanation and problem solution relate to understanding. The temporal properties include the problem solving duration and the self-explanation duration. In this analysis, we measure student performance by the correctness of individual homework assignments. The results of this analysis provide valuable insights about the behaviors of successful and unsuccessful students. Additionally, these techniques form the basis of a novel automated assessment technique for evaluating student performance.

1. Introduction

Self-explanation is the process by which a student explains his or her solution process, summarizing his or her understanding. Prior work has demonstrated that self-explanation can improve a student's metacognitive skills, leading to improved learning gains. These studies typically focus on summative assessments of students' learning, demonstrating, for example, that students who were asked to provide self-explanation of their homework solutions perform better on exams than students who did not provide self-explanation.

In this work, we present a novel technique which provides a formative analysis of self-explanation, determining behaviors which correlate with good performance. In particular we employ machine learning techniques to identify successful patterns latent in students' self-explanations.

This analysis is enabled by our unique dataset of students' handwritten coursework. We conducted a study in which students in an undergraduate Mechanical Engineering Statics course provided handwritten self-explanations of the major steps they followed when solving each of their homework problems. The students completed the homework and self-explanations using Livescribe™ Smartpens. These devices produce a digital record of students' handwritten work in the form of time-stamped pen strokes, enabling us to see not only the final ink on the page, but also the order in which it was written.

We compute numerical features from this digital record which characterize the vocabulary used and the effort (time) expended, both in solving problems and writing self-explanation. Using these features we compute a statistical model which predicts students' grades on various homework assignments. This model accounts for 32.9% of the variance in the students' performance. Furthermore, the underlying parameters of this model provide valuable insights into the ways students explain their own work, and the cognitive processes students employ when asked to self-explain.

2. Related Work

Chi et al.¹ argue that “the metacognitive component of training is important in that it allows students to understand and take control of their learning process.” Metacognition is the awareness of one's own learning process, and it serves as a major foundation for research performed on self-explanation.

Mayer² used metacognition as a context for examining the differences between retention and transfer. The former is the application of knowledge from one problem to a similar problem, while the latter is the application of that knowledge to a different problem. Mayer argues that metaskill is an essential part of transfer. While metacognition is the awareness of one's own cognitive processes, metaskill is the ability to control and monitor those processes. Metaskill strategies may be taught just as any other skill, such as arithmetic, via strategy instruction. For example, students who are taught basic reading skills as well as strategies for summarizing their own reading, perform better on transfer questions³. These results demonstrate the inadequacy of teaching only basic skills and the need to complement them with metacognitive skills. In this context, we use self-explanation as a means to develop metaskills.

Numerous studies have demonstrated the positive impact self-explanation has on student performance. Bielaczyc et al.⁴ studied the impact of different self-explanation strategies on a student's ability to learn LISP programming. In their experiment, students were given instruction via an intelligent tutoring system. Some students were also trained to ask themselves a series of questions regarding their own understanding of worked-out examples they viewed with the tutorial. The experiment revealed a significant difference between the learning gains from the pre- to posttest between students that did and did not generate self-explanation. In this study students provided self-explanation after viewing study materials but before solving problems. This differs from our study in which students generate self-explanation throughout their solution process.

Chi et al.⁵ stated that, “generating explanations to oneself facilitates the integration of new knowledge.” To verify this statement, the authors conducted a study in which eighth-grade

students were asked to provide self-explanation as they read passages from a text on the circulatory system. This demonstrates that students who generated self-explanation performed significantly better than those who did not. This study differs from ours in that students explained passages they read, whereas in our study, students explained their own solution processes.

Chi et al.¹ made comparisons between two groups of students: “poor” and “good” performing students. These students were asked to generate self-explanation after studying worked-out example problems. The results of this study demonstrated that students who perform poorly are typically unable to generate sufficient self-explanation of the worked-out example problems.

Weerasinghe and Mitrovic⁶ investigated the impact that self-explanation, paired with the use of an intelligent tutor, has on student performance in a database design course. In the study, students in the experimental group were prompted for self-explanation by the tutoring system whenever they made a mistake. This protocol was used because the authors claim that prompting students to explain most of their problem steps would be “too burdensome,” although no evidence for this is provided. Because there was no statistical analysis, the results were inconclusive.

Hall and Vance⁷ investigated the impact that self-explanation has on student performance as well as self-efficacy in a statistics course. Students in the experimental group collaboratively solved problems in teams of three, providing self-explanations of the reasoning behind their answers to one another. Students in a control group solved the same problems individually. This study showed that students who generated collaborative self-explanation performed significantly better at solving problems than students who did not. What these studies have in common is their use of summative performance assessments to show the positive impact that self-explanation has on learning gains. To our knowledge, prior work has not used automated, formative assessments which capture changes in students’ solution behavior.

3. Experimental Design

In the winter quarter of 2011, we conducted a study in which students enrolled in an undergraduate Mechanical Engineering Statics course were given Livescribe™ Smartpens. These devices serve the same purpose as traditional pens, allowing students to handwrite their homework on paper. Additionally, these devices record a digital copy of the handwritten work as time-stamped pen strokes.

Thirty of the students in the course were asked to provide self-explanation on five of the homework assignments. A typical homework problem is shown in Figure 1. These problems required students to solve for unknown forces that result when external forces are applied to a system. Students were provided with four to six prompts eliciting explanations for each of the major solution steps. An example of a typical self-explanation prompt is, “Why did you select the system that you used for your free-body diagram.” Students wrote responses to these questions and submitted them along with the solutions to the problems.

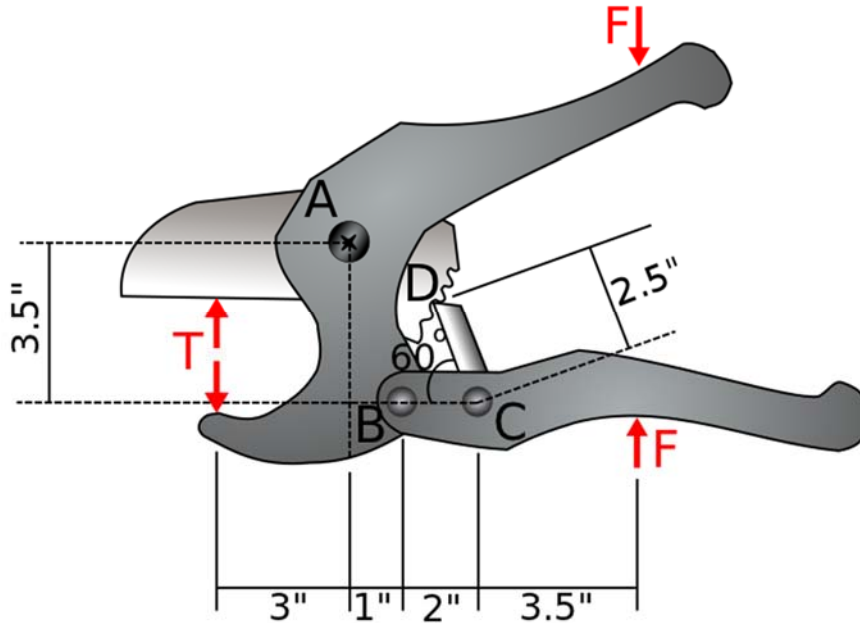

Figure 1 – A typical homework problem from an undergraduate Statics course. The problem description reads, “The device shown is used for cutting PVC pipe. If a force, $F = 15$ lb, is applied to each handle as shown, determine the cutting force T . Also, determine the magnitude and the direction of the force that the pivot at A applies to the blade.”

4. Data Processing

We manually transcribed each handwritten self-explanation, producing 469 text documents. Each document contains all self-explanation written by a single student for a single homework assignment. During this manual transcription we made slight modifications to the students’ explanations to make them suitable for later processing. First, we corrected spelling mistakes, but did not correct grammatical errors. Second, we replaced each verb with its unconjugated form. For example, we replaced “pushed” (past tense) with “push” (infinitive). Our later analysis counts the number of occurrences of words based on exact spelling. These changes ensure that spelling errors and variations in verb tense do not prevent words from being correctly identified.

We also developed a thesaurus to replace synonymous words with a single, canonical word. Students use a variety of words to refer to a given concept or object. For example, when students describe a free-body diagram, they often use the terms “system” and “body” interchangeably. To ensure that semantically identical words are identified as such, we manually developed a thesaurus that maps a canonical concept to each of the words that may be used to express the concept. For example, we created a “free-body diagram element” concept category that comprises every word that students used to refer to any component (body) in a free-body diagram, such as “jaw” or “handle”. In this example, whenever the word “jaw” was found in a transcript, it was replaced with the token “FBD-Element”.

The exhaustive list of concept categories comprises: the *free-body diagram element* category which comprises words that name components in free-body diagrams; the *interaction* category which comprises words that refer to the locations of interactions within a system such as point “A” in Figure 1; the *force* category which comprises words which refer to forces present in a system such as force “F” in Figure 1; the *action* category which comprises words which refer to actions that result from forces acting upon the system such as “spin” or “rotate”; the *solving* category which comprises words which refer to the steps students took in solving a problem such as “calculated” or “computed”; the *two-force member* category which comprises any words which refer to a two-force member in a free-body diagram; and the *direction* category which comprises any words which refer to the direction in which a force may act such as “left” or “perpendicular”.

There were approximately 1500 unique words used by students across all documents. After applying our thesaurus-based replacement, there were 848 unique words.

5. Vocabulary, Effort, and Performance Features

In this section we describe the numerical features which characterize: the vocabulary employed by a student in his or her self-explanation; the effort expended on a problem solution; the effort expended on a self-explanation; and the performance on a homework assignment.

We use the “term frequency — inverse document frequency” score (TF-IDF) to characterize the importance of each word in a transcribed self-explanation document. TF-IDF is the product of two terms, the first of which, *term frequency*, is defined as:

$$F(t, d) = \frac{f(t, d)}{\max_{w \in d} f(w, d)}$$

where t is a given word, and d is a text document containing the self-explanation responses for a single student for a single homework assignment. $f(t, d)$ is the frequency with which word t occurs in document d . $F(t, d)$ characterizes the importance of a word within a document by comparing it to the most frequently used word in that document.

The second term in the TF-IDF score, which is called *inverse document frequency*, is defined as:

$$I(t, D) = \log \frac{|D|}{|\{d \in D: t \in d\}|}$$

where D is the set of all documents, and $|D|$ is the total number of documents. $|\{d \in D: t \in d\}|$ is the number of documents in D that contain the term t . Thus, $I(t, d,)$ characterizes the importance of a word across all documents.

Finally, the TF-IDF score (S) is simply the product of the two previous terms:

$$S(t, d, D) = F(t, d) \cdot I(t, D)$$

The TF-IDF scores of all words encountered in all documents are used as features. Additionally, we compute two features that characterize the effort spent on an assignment and the corresponding self-explanation. Specifically, we use the timing information recorded with the digital pens to compute both the amount of time a student spent writing the solutions for an assignment and the time spent writing the self-explanations.

Our goal is to use the features to predict a student's performance on homework. Because the distribution of grades varies from one assignment to the next, we used z-score normalization to normalize the grades:

$$z = \frac{g - \mu}{\sigma}$$

Here g is a particular student's grade on an assignment, μ is the mean grade for all students on that assignment, and σ is the standard deviation of the grades for that assignment.

6. Feature Subset Selection

Given that there are 848 unique words across all explanations, there would be 850 features (two features represent effort) computed for each of the 469 documents. This is too large a feature set and would lead to an over-fit model with inflated accuracy. To address this issue we employ a heuristic search to identify which of the features are the best predictors of performance.

This search comprises two major steps. In the first step, the K-Means⁸ clustering algorithm is used to identify a subset of features that are potentially valuable in predicting student performance. Second, we apply the more computationally expensive Correlation Feature Selection (CFS) algorithm⁹ to further refine the final feature set.

In the first step, we apply the K-Means clustering algorithm to the documents which are represented with the full set of 848 word-based features. This algorithm finds groupings of documents such that members of each group are more similar to each other than to members of the other groups. K-Means requires that k , the number of groups, be selected *a priori*. We use a value of $k = 7$. This value provides enough resolution to identify distinct groups without over-fitting the data with small clusters. We analyzed the mean value of each feature for each of the seven groups. We then used a simple heuristic to identify which features are the most useful for distinguishing between the groups. For each group, we compute the average value of each feature. We then rank each feature by its "range" defined as the difference between its maximum and minimum group averages. We then select the 100 features with the largest ranges.

Next, we apply the CFS algorithm to produce a smaller feature set. This algorithm begins with an empty feature set and iteratively adds the feature that is both maximally correlated with the predicted grade and minimally correlated with the features selected so far. This algorithm terminates once all features have been selected and returns the subset that had the greatest accuracy. For our data, the final subset comprises 31 features.

7. Predicting Student Performance

To build a model to predict homework performance, we combine the 31 word features identified with our subset selection algorithm with the two effort-based features. We use these features to train a linear regression model to predict the performance of each student on each assignment. We compute the model using the linear regression package available in the WEKA¹⁰ machine learning software suite. The resulting model is able to explain 32.9% ($R^2 = 0.329$) of the variance in students' grades.

Attribute	Weight	Attribute	Weight	Attribute	Weight
think	-2569.89	it	-504.657	verge	883.3293
least	-1322.77	have	-394.529	into	913.0861
another	-1048.22	the	-142.326	will	943.609
had	-1025.94	exp. time	0	but	962.6868
assume	-926.469	sol. time	0	seemed	978.6742
out	-908.426	solving	142.0982	surface	1115.704
since	-893.815	I	179.5696	we	1239.407
there	-781.706	system	354.7273	don't	1244.825
with	-740.61	would	608.0972	around	1283.142
could	-710.309	all	720.3185	found	1393.27
so	-706.936	it's	835.4367	cancel	1999.689
find	-662.409	Get	845.1465	started	2057.791
that	-533.202				

Table 1 – Coefficient weights for each feature of the model trained using linear regression. Most attributes are the TF-IDF score of the particular word. “exp. time” and “sol. time” are the amount of time spent generating the self-explanation and the amount of time spent solving problems, respectively.

Table 1 shows the coefficient weights for each of the features in the regression model. The magnitude of each weight indicates the predictive power of that feature in determining students' performance. Similarly, the sign of the weight indicates whether or not that feature correlates positively or negatively with performance.

8. Discussion

The accuracy of our model for predicting student grades is encouraging. More interesting though, is the fact that the model and its parameters provide valuable insights into the self-explanation behaviors that lead to strong or weak performance. In particular, the coefficients of the model provide insights as to what types of self-explanations are indicative of students who performed well and those who did not.

Take, for example, the feature with greatest weight, the TF-IDF score of the word “started”. By manually inspecting the self-explanation responses that contain this word, we found that the word “started” is typically used by a student to explain that he or she started solving a problem in a particular way, realized a fundamental error, and then started over with a different approach. This provides strong evidence of learning taking place. The large weight of this feature indicates

that students who catch and repair their own mistakes are likely to do well on homework assignments.

Similarly, consider the word “think”, which has the most negative weight. By manually inspecting the self-explanation responses which contain this word, we found that students typically use the word “think” to express uncertainty in their solution. For example, students often used the word “think” when stating that they could not think of an alternative way to solve the problem, or that they could not think of a better point about which to take a moment. It was often the case that when a student stated this, there was in fact a better alternative that would have led to a more correct solution. Thus the word, “think” is often an indication that the student fails to see the correct solution path.

In the present work, we have only begun to examine the significance of the words that are important in the final model. We expect that further analysis will reveal additional insights which we will continue to examine in future work.

It is worth noting that both of the effort-based features had a coefficient value of zero, indicating that they provide no more information in determining a students’ grade than the remaining 35 features. This suggests that the amount of effort exerted by a student on a homework assignment may correlate with the vocabulary choices of their self-explanation.

9. Conclusion

In this work, we have demonstrated a novel technique for analyzing students’ handwritten self-explanations of their homework solutions. This technique is enabled by our unique dataset of student work. We conducted a study in which thirty students in an undergraduate Mechanical Engineering Statics course provided handwritten self-explanations of the major steps they followed when solving each of their homework problems. The students completed the homework and self-explanations using Livescribe™ Smartpens. These devices produce a digital record of students’ handwritten work in the form of time-stamped pen strokes, enabling us to see not only the final ink on the page, but also the order in which it was written.

We compute numerical features from this digital record which characterize the vocabulary used and effort expended in constructing handwritten self-explanations. We applied a heuristic subset selection algorithm to identify the optimal subset of features for predicting homework performance. Using this subset, we computed a linear regression model that predicts students’ grades on homework assignments. This model accounts for 32.9% of the variance in the students’ performance. While this is a strong correlation, what is more valuable are the insights that can be drawn from the underlying parameters of this model. The coefficient weights of the model may be used to guide manual analysis of the students’ self-explanation responses, revealing patterns that provide insights into the types of self-explanation behaviors that are indicative of understanding or lack thereof.

References

*Proceedings of the 2013 American Society for Engineering Education Pacific Southwest Conference
Copyright © 2013, American Society for Engineering Education*

- [1] T. H. Michelene; Miriam Bassok; Matthew W. Lewis; Peter Reimann; Robert Glaser Chi Self-explanations: How students study and use examples in learning to solve problems. In *Cognitive Science*, pages 145–182, 1989.
- [2] Richard E. Mayer. Cognitive, metacognitive, and motivational aspects of problem solving. *Instructional Science*, 26(1-2):49–63, 1998.
- [3] A.L. Brown and J.D. Day. Macrorules for summarizing texts: The development of expertise. *Journal of Verbal Learning and Verbal Behavior*, 22:1–14, 1983.
- [4] Katerine Bielaczyc, Peter L. Pirolli; and Ann L. Brown. Training in self-explanation and self-regulation strategies: Investigating the effects of knowledge acquisition activities on problem solving. *Cognition and Instruction*, 1995.
- [5] Michelene T. H. Chi, Nicholas De Leeuw, Mei hung Chiu, and Christian Lavancher. Eliciting self-explanations improves understanding. *Cognitive Science*, 18:439–477, 1994.
- [6] Amali Weerasinghe and Antonija Mitrovic. Supporting self-explanation in an open-ended domain. In Mircea Negoita, Robert Howlett, and Lakhmi Jain, editors, *Knowledge-Based Intelligent Information and Engineering Systems*, volume 3213 of *Lecture Notes in Computer Science*, pages 306–313. Springer Berlin, 2004.
- [7] Simin Hall and Eric A. Vance. Improving self-efficacy in statistics: Role of self-explanation and feedback. *Journal of Statistics Education*, 2010.
- [8] MacQueen, James. "Some methods for classification and analysis of multivariate observations." *Proceedings of the 5th Berkeley symposium on mathematical statistics and probability*. Vol. 1. No. 281-297. 1967.
- [9] Hall, Mark A. Correlation-based feature selection for machine learning. Dissertation The University of Waikato, 1999.
- [10] Mark Hall, Eibe Frank, Geoffrey Holmes, Bernhard Pfahringer, Peter Reutemann, Ian H. Witten (2009); The WEKA Data Mining Software: An Update; *SIGKDD Explorations*, Volume 11, Issue 1.

Simple Experiments and 3-D COMSOL Simulations to Enhance the Learning of Transient Heat Transfer

Sergio Mendez and Lisa AungYong

Department of Chemical Engineering, California State University, Long Beach

Abstract

Engineers are at the cutting edge of implementing technologies to garner energy from sustainable sources or to make processes more energy efficient. Therefore, it is imperative that we provide a solid education regarding the principles of heat transfer. To keep competitive on a global scale, it also becomes important to train students on the latest computational software. In the chemical engineering curriculum, students are first taught the principles of heat transport in a lecture course. Many students, however, struggle with the calculus-based math required to solve the heat transfer equations, and they do not fully make the connections between the concepts of conduction and convection and real world phenomenon. To further increase understanding, students are often given the opportunity to perform relevant experiments in a subsequent undergraduate lab course. We report on a combined experimental and computational module that can be incorporated into lecture or lab courses to enhance student learning about transient heat conduction/convection. The experimental set-up is low-cost and simple: first heat a cylindrical solid to an elevated temperature, then remove the solid from the heat source, and measure the temperature versus time cooling profile. There is heat conduction through the solid, and convective heat transfer to the ambient air. The students then compare the temperature profile with the results from a computer simulation. The two teaching aims are 1) for students to perform a hands-on activity that enables them to make the connection between textbook concepts and real-world observation, and 2) to give students the skills to employ the state-of-the-art, user-friendly, commercially available computer modeling software, COMSOL Multiphysics. The effectiveness of this teaching module was assessed with student opinion surveys. Based on these results, we found that this module improved student understanding of heat transfer, and that their level of enthusiasm increased due to experiential, hands-on measurements and computer simulations.

Introduction

Most engineering students are taught the concepts and mathematics of heat transfer, but are not given the opportunity to fully grasp the practical aspects of this phenomenon. As an indication of its importance, many engineering disciplines include heat transfer as a core course in their undergraduate and graduate curricula. Unfortunately, this topic can be unappealing to students because of the rigorous mathematical derivations and because they do not get a tangible understanding of the concepts covered in lectures and textbooks. Laboratory experiments are often performed in undergraduate lab courses, but once again, the students tend to find many of these uninteresting, thus they remain un-excited about the topic of heat transport. Hunkeler et al.¹ reported that 42 % of engineering students are “hands-on common sense learners” as defined by Kolb’s Learning Styles.²

The learning experience of students can be enhanced with classroom demonstrations, hands-on experimentation or computer simulations. Heat transfer has been the focus of many literature papers. There are some papers where simple experiments have been developed to enhance teaching. Nassar performed experiments on a simple flow vessel apparatus to determine

the convective heat transfer coefficient, and compared it with empirical correlations from the literature.³ Clausen developed experiments in free and forced convection for flat and circular geometries,⁴ and Smart combined classroom lectures and short experiments where potatoes were cooked.⁵ Desktop experimental modules in transient heat transfer have also been reported on.⁶

Many papers have been published that demonstrate how computational methods can be used to enhance student learning of heat transfer concepts. Spreadsheets^{7,8} and Matlab programming⁹ have been used to numerically solve partial differential equations in heat transfer problems. A combination of experimentation and computer simulation have been reported by Hossain et al. who measured the temperature distribution along a length of a metal fins, and found good agreement with their numerical solution of partial differential equations and with one-dimensional ANSYS computer simulations.¹⁰ Doughty and O'Halloran performed experiments on heat transfer from metal and acrylic cylinders, then conducted finite element calculations that were implemented with spreadsheets or Matlab programming.^{11,12} To understand student perception of specific computer programs, a survey of numerical methods used in various chemical engineering programs has been published.¹³

To be competitive in the global economy, chemical engineering students must keep abreast of the latest technological trends. As educators, we should elucidate the capabilities and advantages of modern low-cost, user-friendly commercial software that do not require writing computer programs. Many of the vendors are adding more functionality into their software packages, thereby giving the end-user greater modeling capabilities. In this work, we introduced students to “COMSOL Multiphysics”,¹⁴ and used it as an educational tool that can enhance the learning of heat transfer concepts. Other engineering educators have employed COMSOL for educational purposes to model mass transfer,¹⁵ heat conduction in a fin,⁷ and hydrogen fuel cells.¹⁶

In this paper, we first describe the experimental and computational methods that were employed to study heat transfer. The computational simulation results are validated by comparison with the experimental measurements. We end the paper by providing the results of a student questionnaire that was used to assess the effectiveness of this combined module on the student learning of heat transport.

Experimental methods

Materials. Two solid cylinders with the same dimensions were used in the laboratory experiments (diameter = 0.0381 m, height = 0.130 m). The two solids were chosen to have significantly different thermal properties: an aluminum alloy (7055), and the other was ultra-high molecular weight polyethylene. In Table 1 we list the density (ρ), heat capacity (C_p) and thermal conductivity (k) for the two materials. According to these thermal properties, the temperature of the aluminum should decrease faster than the plastic, if both samples started at the same initial temperature.

Table 1. Material properties of aluminum and polyethylene.

Material	Density, ρ (kg/m ³)	Heat Capacity, C_p (J/kg*K)	Thermal Conductivity, k (W/m*K)
Aluminum	2,710	1,256	167
Polyethylene	950	2,301	0.52

In Figure 1 there are images of the solid cylinders. Staggered holes were drilled from the top of the cylinders so that thermocouples could be inserted to monitor the temperature at half the column height. As seen in Figure 1 (right), four holes were drilled at various distances from the center: $r=0$, $R/4$, $R/2$ and $3R/4$ where R is the radius of the cylinder.

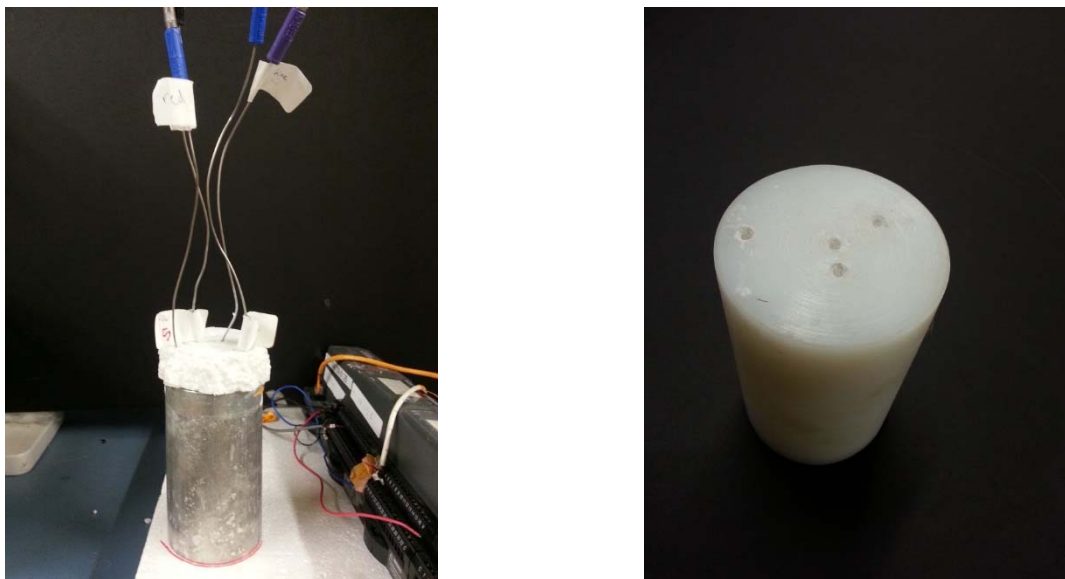

Figure 1. Photographs of the aluminum (left) and polyethylene (right) solid cylinders. Thermocouples were inserted into drilled holes. The solids were placed on a thermally insulated Styrofoam surface, and the top was insulated with a Styrofoam disc.

Procedure. The experimental procedure involved first heating the cylinders to an elevated temperature (~ 60 °C), and then removing them from the heat source and monitoring the temperature versus time as the solid cooled to ambient room temperature (~ 24 °C). The heating sources were either a lab oven or a stirred water bath. The solids were kept in the heating sources until the temperatures at all four radii were equal. After reaching thermal equilibrium, the samples were removed from the heat source and placed on a thermally insulated Styrofoam surface. Thermocouples were immediately inserted in the drilled holes and a Styrofoam disk was used to insulate the top surface. A LabView program was used to record temperatures with E, J and T type thermocouples connected into a FieldPoint data acquisition system. With this arrangement, we expected that most of the heat would be transferred radially from the cylinder. We performed experiments such that heat from the warm cylinders was transferred to the cooler room temperature air via free convection.

Computational methods

COMSOL Multiphysics version 4.2a was used to simulate the transfer of heat from the cylinders to the surrounding air. The geometry used was a 3-dimensional half cylinder since we assumed that heat conduction within the cylinder occurred entirely in the radial direction. The dimensions of this shape were drawn to match those of the actual full solid cylinders.

COMSOL employs finite element numerical methods to solve partial differential equations (PDEs). This commercially available software conveniently provides PDEs for various phenomena. Since we are only considering heat transport, we used the built-in “Transient Heat Transfer” module. When this is invoked, the software solves this PDE:

$$\rho C_p \frac{\Delta T}{\Delta t} = \nabla \cdot (k \nabla T) + Q \quad \text{Equation 1}$$

where Q is a convective heat flow per area term. To model the experiment, we assumed convective heat transfer from the hot cylinder to the cool room. This was accounted for with the following equation,

$$Q = h (T_{ext} - T_s) \quad \text{Equation 2}$$

where T_{ext} is the ambient room temperature, T_s is the temperature at the surface of the cylinder, and h is the convective heat transfer coefficient. We employed the same method as Doughty et al. to approximate the h from experimental measurements.¹¹ They used the following equation,

$$\ln \left[\frac{T_c - T_{ext}}{T_i - T_{ext}} \right] = -\frac{1}{\tau} \quad \text{Equation 3}$$

where T_c is the transient centerline temperature at $r = 0$, and T_i is the initial temperature. τ is

$$\tau = \frac{\rho V C_p}{h A_s} \quad \text{Equation 4}$$

where V and A_s are the volume and surface area, respectively. The experimental temperature data was plotted as a function of time according to Equation 3, and a linear fit yielded the heat transfer coefficient. For the aluminum cylinder, we found values of $h = 13.8 \text{ W/m}^2 \text{ K}$ which are in reasonable agreement with the h values reported by Doughty for free convective cooling.¹¹

In Figure 2, we show pictorially the important aspects of the COMSOL model. The boundary conditions are shown in the first three images: insulated surfaces are the top and bottom of the cylinder along with the flat surface that is in the axial direction; convective heat transfer between the warm cylinder and the air occurs at the surface of the cylinder, and finally, we assumed that there is zero heat flux at the $r=0$ centerline axis.

Boundary Conditions

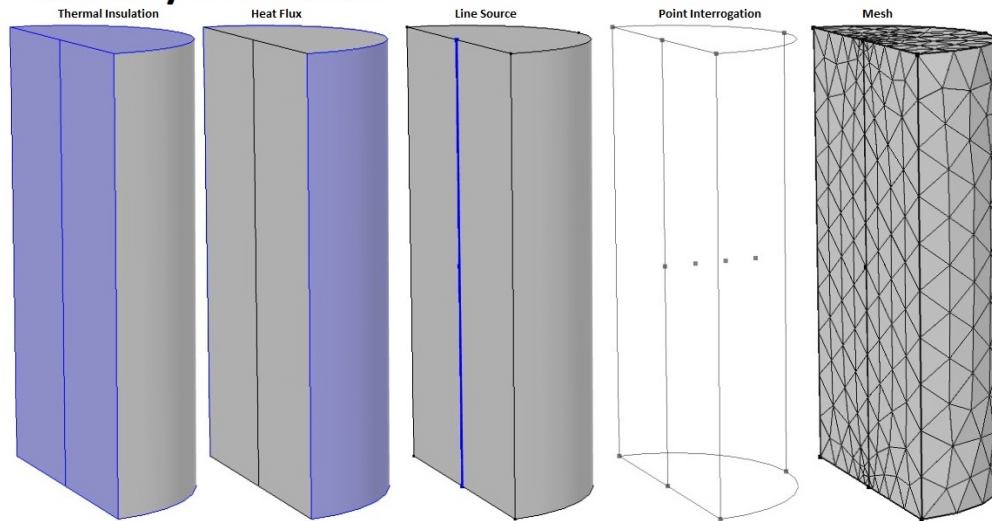

Figure 2. Geometric shape used in the COMSOL model. From left to right: thermal insulation, heat flux and line source boundary conditions. The fourth image shows the position of the points where the temperature was recorded. The fifth image shows the mesh.

The fourth image shows the position of the four points where the temperature profiles were recorded. These are mid-way in the length of the cylinder and at positions that match the drilled holes of the actual solids: $r=0$, $R/4$, $R/2$ and $3R/4$. The fifth image shows the default triangular mesh that was used.

Results

In Figure 3, we present the experimental and computational results for the cooling of the aluminum cylinder with free convection. The experimental data shows that the temperature cools from an elevated temperature of 58 °C to room temperature near 25 °C over a span of 5 hours. The profiles for all four radial distances are very similar with the profile at $r=3R/4$ being only slightly less than the other profiles. For aluminum we expect from the Biot number that the heat will be transported rapidly and that the radial temperatures will be similar. The Biot number is

$$Bi = \frac{hR}{2k} \quad \text{Equation 5}$$

With the value of $h = 13.8 \text{ W/m}^2 \text{ K}$, we get $Bi=0.00079$. Since it is less than 0.1, we predict that the temperature at $r=0$ will be almost the same as the temperature at $r=3R/4$. To make a direct comparison, we also plot the results from the 3-dimensional COMSOL simulations on Figure 3. For all four temperature profiles, there is excellent agreement between experiments and COMSOL, therefore, indicating that our model has some accuracy.

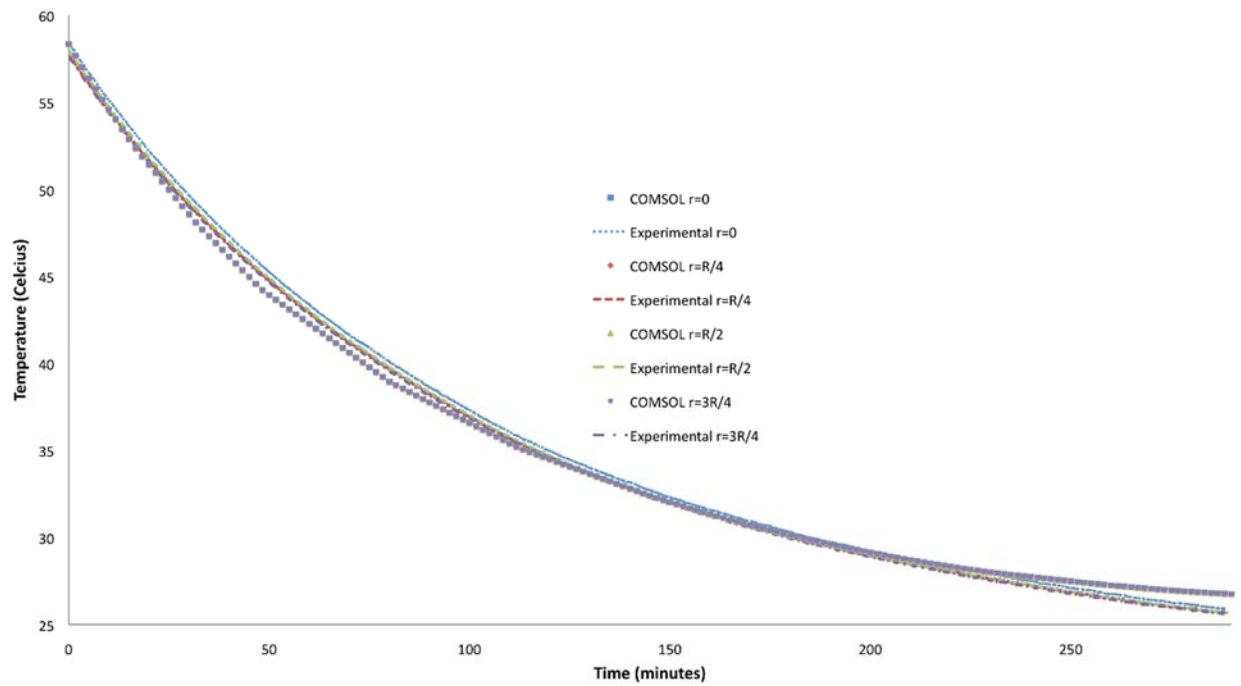

Figure 3. Temperature profiles for aluminum cylinder at four radial positions. Experimental data as curves and COMSOL results as symbols.

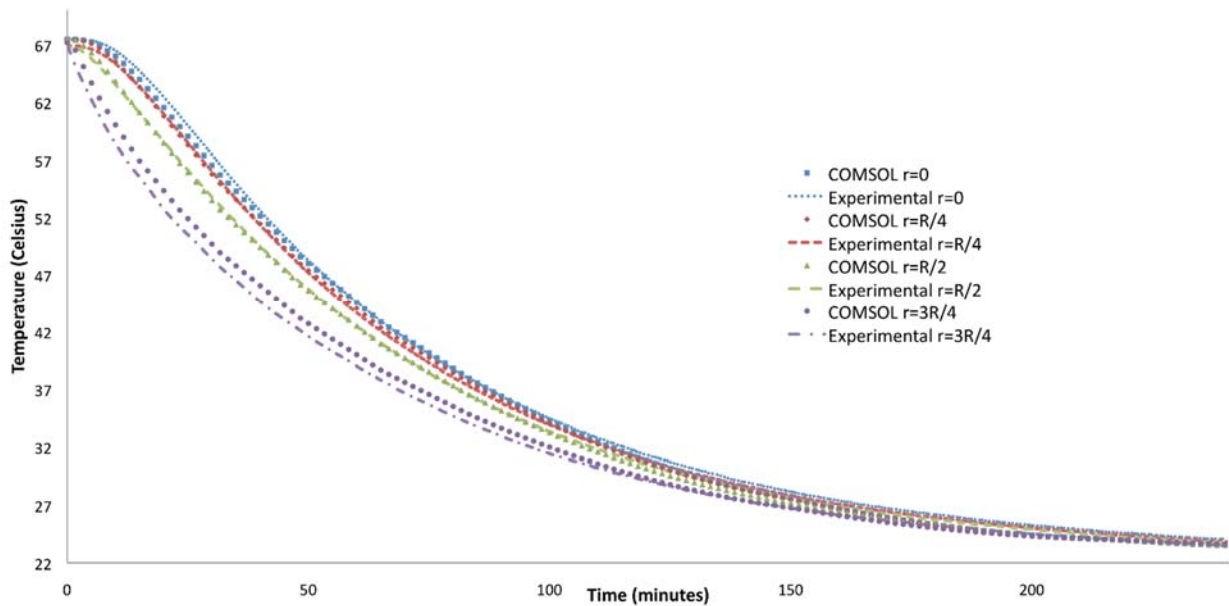

Figure 4. Temperature profiles for polyethylene cylinder at four radial positions. Experimental data as curves and COMSOL results as symbols.

In Figure 4, there is a corresponding plot for the polyethylene solid cylinder. The experiment was run in the same way except the initial temperature of the entire cylinder was 67 °C. For the temperature to drop about 30 °C relative to the starting point, it took about 4 hours for the aluminum cylinder and about 1.5 hours for the polyethylene cylinder. As noted earlier, we expect the aluminum sample to cool off faster than the plastic sample only if both had the same initial temperature. As noted in the data, the aluminum had an initial temperature that was 10 °C lower than the plastic, therefore, we can make a direct comparison of the cooling rates. With the value of $h = 14.5 \text{ W/m}^2 \text{ K}$, the Biot number is $Bi=0.27$. From this we predict that there will be differing temperatures at the four different radial distances. Indeed, the experimental data does exhibit the wide differences in temperature at times less than 150 minutes. Again, COMSOL simulations exhibit excellent agreement with experimental measurements.

Modeling heat transfer with COMSOL has advantages that include relative ease of use, 3-dimensional geometry, and capability of visualizing simulation results in ways that not only help to increase student learning, but also provide information not readily available for real systems. We can take advantage of the built-in graphing functions of COMSOL to view the 3-dimensional time evolution of heat transfer. This type of information is almost impossible to obtain experimentally. In Figure 5, we present colored “slice plots” with the color palette for the polyethylene solid. The temperature is represented by a color scheme defined on the included color palette where the two extremes of deep blue corresponds to 20 °C and deep red to 70 °C. We arbitrarily divided the cylinder into ten evenly spaced slices in the axial direction. Experimentally, at $t=0$, the entire polyethylene cylinder is at a single temperature: we can observe that all slices have the same temperature (i.e., red color). From Figure 4, the profiles indicate that at $t=1000$ seconds (16 minutes), the temperatures profiles are widely different. The slice plot likewise shows that near the center the color is orange, and at the surface, the color is yellow—this color difference corresponds to differences in temperature. This demonstrates the power of the COMSOL software, and hopefully, piques the student’s interest in computational modeling and heat transfer.

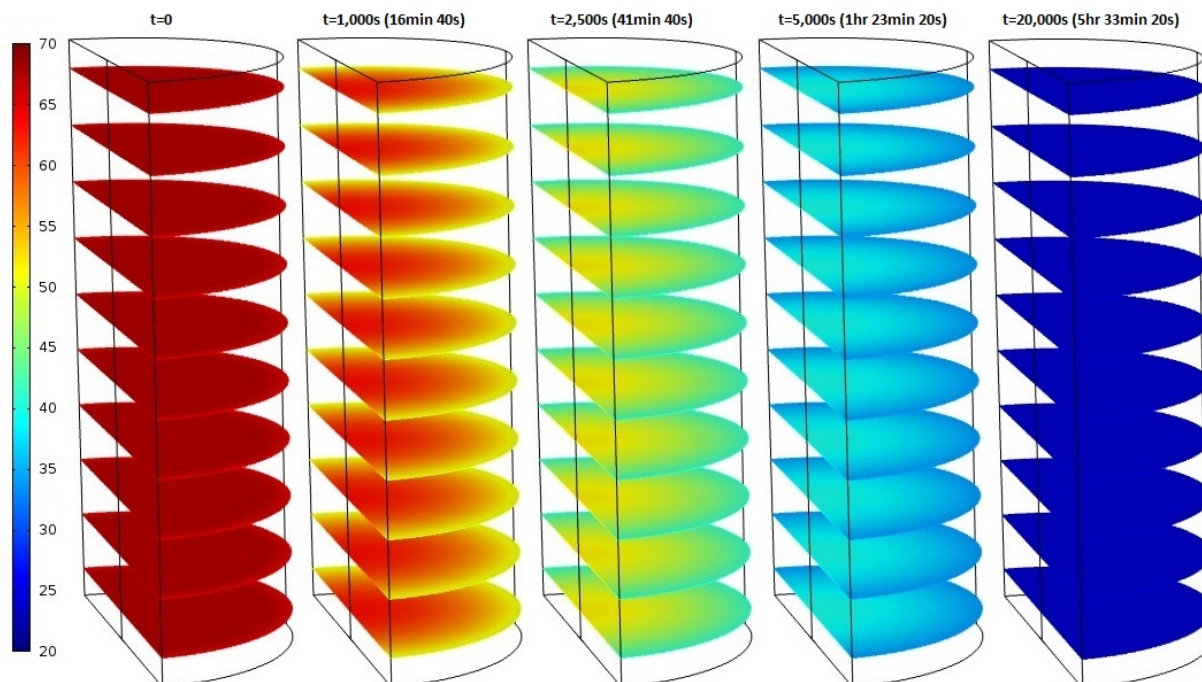

Figure 5. COMSOL slice plot with color palette for polyethylene cylinder. Snap shots were taken at various times in the simulation.

Assessment of student learning

The two main objectives of this work were to develop a combined experimental and computational module to 1) increase student’s understanding of heat transfer, and 2) to introduce them to a modern computational tool to model this phenomenon. To determine the degree to which we met our objectives, we asked students to respond to a list of questions. The undergraduate students queried were enrolled in “Chemical Engineer 420, Heat and Mass Transfer” and/or “Chemical Engineer 440, Undergraduate Laboratory I” in the Department of Chemical Engineering at California State University, Long Beach.

Table 2. Results from student questionnaire.

Questionnaire Statement	% of Students Surveyed				
	5	4	3	2	1
1. Listening to the lecture and doing homework was the most useful in helping me grasp the concept of transient heat conduction	21	5	57	12	5
2. Conducting the experimental measurements was the most useful in helping me grasp the concept of transient heat conduction	62	31	3	4	0
3. Performing the COMSOL simulations was the most useful in helping me grasp the concept of transient heat conduction	5	8	24	49	14
4. This teaching module increased my interest in transient heat conduction	20	44	25	10	1
5. I prefer this type of combined teaching module than only laboratory experiments.	13	14	33	37	3
6. I feel that it is appropriate to require students to perform this type of hands-	4	15	35	41	5

on/computational teaching module in a lecture course.					
7. I would like for the faculty to develop such teaching modules for other chemical engineering courses.	33	39	11	17	0
8. I plan to learn more about COMSOL Multiphysics and try to perform simulations on my own.	24	5	28	21	22

5=[strongly agree], 4=[agree], 3=[no opinion], 2=[disagree], 1=[strongly disagree]

The overall impression from the student survey is that they indeed agree that hands-on experiments do help them learn about heat transfer, however, they do have some reservations about conducting COMSOL simulations. This is evident in the responses to questions 1-3. This might be due to the additional computational skills and knowledge that must be acquired to effectively perform the COMSOL modeling. Despite their preferences to not have to learn COMSOL, the students do appreciate the educational value of this added module as evident in their responses to questions 5-7. To lessen the anxiety of performing COMSOL simulations, in the future, we plan to introduce the software in lower division courses, and to provide students with step-by-step operating instructions. We have an ongoing effort to directly assess with quizzes the extent to which this experiment/simulation module is improving student learning about heat transfer.

Summary and conclusions

In this paper, we have reported on a teaching module that combines both experimental measurements and computational modeling of heat transfer phenomena. The experimental set-up was relatively simple, and the procedure was easy. COMSOL Multiphysics was employed to model the convective cooling of both aluminum and polyethylene solid cylinders. With proper choice of the heat transfer coefficient we found excellent agreement between experiment and computer simulation. In addition, we demonstrated how the software could be used to garner information that would otherwise not be available experimentally.

From the student questionnaire we found, overall, that students find value in this module, however, the computer software does require some time and dedication to learn. In the future, we hope to alleviate their concerns about learning the software so that they can become comfortable and proficient in its usage.

Acknowledgements

We thank professor Larry Jang and Mr. Minh Tran for helping us with the experimental set-up, and Ms. Sophia Nguyen for helping with the initial COMSOL modeling.

References

1. Hunkeler, D. and Sharp, J.E., "Assigning Functional Groups: The Influence of Group Size, Academic Record, Practical Experience, and Learning Style", *Journal of Education*, Vol. 86, No. 4, 1997, pp. 321-332.
2. Kolb, D.A., *Experiential Learning: Experience as the Source of Learning and Development*, Prentice Hall, Englewood Cliffs, NJ, 1984.
3. Nassar, N.N., Mehrotra, A.K., "Design of a Laboratory Experiment on Heat Transfer in an Agitated Vessel," *Education for Chemical Engineers*, Vol. 6, 2011, pp. e83-e89.
4. Clausen, E. and Penny, W., "Laboratory Demonstrations/Experiments in Free and Forced Convection Heat Transfer Course," American Society of Engineering Education Conference proceedings, 2006, #1488.
5. Smart, J.L. "Optimum Cooking of French Fry-Shaped Potatoes," *Chemical Engineering Education*, 2003, pp. 142-153.
6. Minerick, A., "A Desktop Experiment Module: Heat Transfer," American Society of Engineering Education Conference proceedings, 2009, #1609.
7. Geike, R., "Comsol Multiphysics in Education-Chemical Reactions, Heat and Mass Transfer," COMSOL Conference proceedings, 2008.
8. Besser, R.S., "Spreadsheet Solutions to Two-Dimensional Heat Transfer Problems," *Chemical Engineering Education*, Vol. 36, No. 2, 2002, pp. 160-165.
9. Goldstein, A.S., "A Computational Model for Teaching Free Convection," *Chemical Engineering Education*, Vol. 38, No. 4, 2004, pp. 272-278.
10. Hossain, N.M. A., Weiser, M.W., Saad, H.S. and Durfee, J.K., "Integration of Numerical and Experimental Studies in a Heat Transfer Course to Enhance Students' Concepts," American Society of Engineering Education Annual Conference proceedings, 2011, #62.
11. Doughty, T.A. and O'Halloran, S.P., "A Cross Curricular Numerical and Experimental Study in Heat Transfer," American Society of Engineering Education Annual Conference proceedings, 2010, #1647.
12. O'Halloran, S.P. and Doughty, T.A., "Integration of Numerical Analysis and Experimental Testing Involving Heat Transfer for a Small Heated Cylinder During Cooling," American Society of Engineering Education Annual Conference proceedings, 2009, #51.
13. Enzer, J.A., Goodrich, V.E., and Getman, R. B., "Improvements in Computational Methods Courses in Chemical Engineering," American Society of Engineering Education Annual Conference, 2012, proceedings #4402.
14. www.comsol.com
15. Ortiz, E., Vazquez, J., Ricardez, L.A., "An Undergraduate Course in Modeling and Simulation of Multiphysics Systems", *Chemical Engineering Education*, vol. 44, no. 4, 2010, pp 299-305.
16. Keith, J., Morrison, F., and King, J., "Finite Element Modules for Enhancing Undergraduate Transport Courses: Applications to Fuel Cell Fundamentals," American Society of Engineering Education Annual Conference, 2007, proceedings #414.

Towards Gender Balance in Engineering for an Expanding Global Market Place

Muge Mukaddes Darwish
Texas Tech University, Lubbock, Texas,
Ali Nejat
Texas Tech University, Lubbock, Texas

Abstract

A global economy requires that engineers understand the importance of both cultural and gender diversity to be more efficient in solving problems in our world of technology and communication. Nearly four decades ago, United States engineers led one of the greatest accomplishments of all time by successfully landing men on the moon and returning them safely to America. Four subsequent crews followed the first crew in successful triumphs. If we recall the picture of those engineers they were all white men in white shirts, most with plastic pocket protectors to hold rows of pens and pencils. This picture is slowly changing, as the field of engineering progresses and evolves. Recent studies showed that there are more women engineers joining the workforce every year, but still not enough to fulfill the gap. Engineering classrooms remain to be dominantly consisted of male students with a national ratio of six to one. The female ratio at the college of engineering in Texas Tech University is much lower than national statistics.

Influential factors of lower interest in women preceding engineering careers are known as "environmental" factors, such as isolation, exclusion from networks, and lack of role models. All of such are a major source of discouragement for girls and women in the field of science and engineering. If engineers are capable of solving complex problems of the world, then they surely can figure out how to improve the enrollment of women into engineering-specific careers. This paper presents possible solutions for revamping the recruitment and retention of female students in untraditional engineering careers.

Keywords: Globalization, gender balance, women in engineering

Introduction:

Globalization reshaped the world with the increasing interaction of cultures and economies to conduct business and commerce including the field of engineering. The economies of the world are increasingly becoming interdependent as companies expand their operations and marketing throughout the world. In this global corporate environment, technical professionals are required to work as part of international teams and devise solutions, which will be implemented across national and cultural boundaries. This new environment requires that engineers understand the importance of both cultural and gender diversity to be more efficient in solving problems in our connected, and technological world.

Despite high unemployment, companies are persistently looking to fill engineering positions with a lacking pool of qualified workers to do the jobs. The shortage of women candidates for those positions is even more apparent. Many fewer women pursue engineering degrees and those who do often end up working in other fields. The NSF Engineering Task force, established in 2005, reported that student's interest in engineering careers declines from high school to college especially among the female students. Even though the number of women in engineering is growing, men continue to outnumber women in the engineering profession. According to the National Center for Education Statistics¹, the number of male engineering graduates rose by 11% from 2004 to 2009, while the number of female engineering graduates actually fell by 5.2% over the same period. In 2009, the percentage of undergraduate degrees from engineering schools that went to women hit 17.8%, a 15-year low, according to the American Society of Engineering Education². In order to create interest in engineering there is a need for change in preparation for engineering study and in the culture of engineering schools. Diversifying the professoriate proceeds slowly, leaving students without role models.

What is Wrong with Education Today?

Education is fundamental to development and is the most important parameter for countries' vitality and growth. In order to have an understanding of why so few females pursue engineering fields, one must examine the paramount problems associated with education in globally. We are in an era that is rapidly moving from an industrialized model of education to a more global, information-age technologically driven education.

Although these changes are observed by society and most industries, it's not that easy to implement changes in schools because the changes require the rethinking of school systems, curricula, and to know what we must expect from students. Schools need reformation as to better introduce science-technology-engineering and math (STEM) young age to students both inside and outside the classroom. Families, teachers, and counselors must inspire and motivate female students as well as the males to show how engineering can be fun and exceptional career choice.

Preparation of Girls in STEM related Fields:

According to the U.S Department of Education National Center for Educational Statistics³ in elementary, middle, and high school, girls and boys take math and science courses in roughly equal numbers, and about as many girls as boys leave high school prepared to pursue science and engineering majors in college¹ see Figures 1 and 2. Yet fewer women than men pursue these majors.

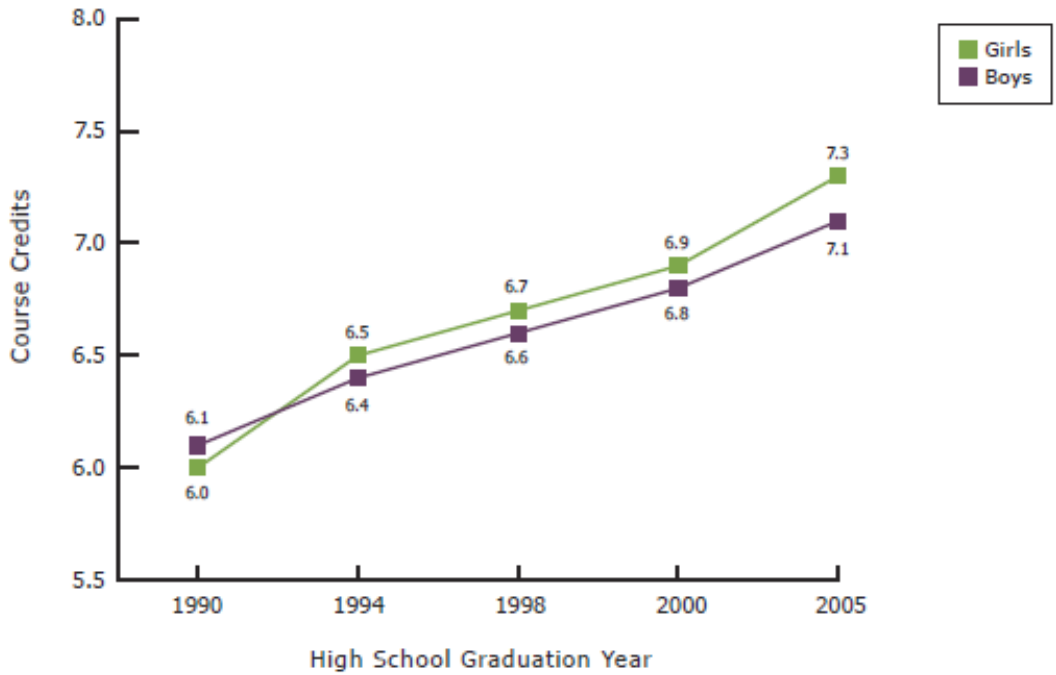

Figure 1. High School Credits Earned in Mathematics and Science by Gender, 1990–2005¹

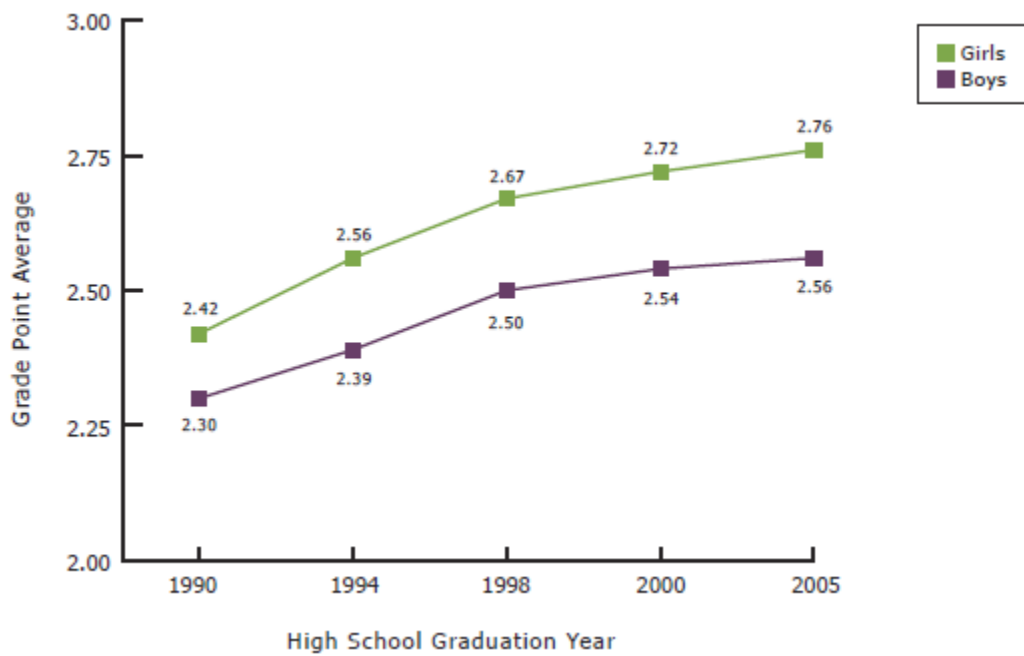

Figure 2. Grade Point Average in High School Mathematics and Science (Combined), by Gender, 1990–2005¹

Historically, boys have outperformed girls in math, but in the past few decades the gender gap has narrowed, and today girls are doing as well as boys in math on average⁴.

Women in Engineering Colleges

Among first-year college students, women are much less likely than men to say that they intend to major in science-technology-engineering and or math (STEM). See Figure 3. By graduation, men outnumber women in nearly every science and engineering field. In some fields, such as physics, engineering, and computer science, the difference is dramatic, with women earning only 20% of bachelor's degrees (see Figure 4 and Tables 3, 4, and 5) Women's representation in science and engineering declines further at the graduate level and yet again in the transition to the workplace.

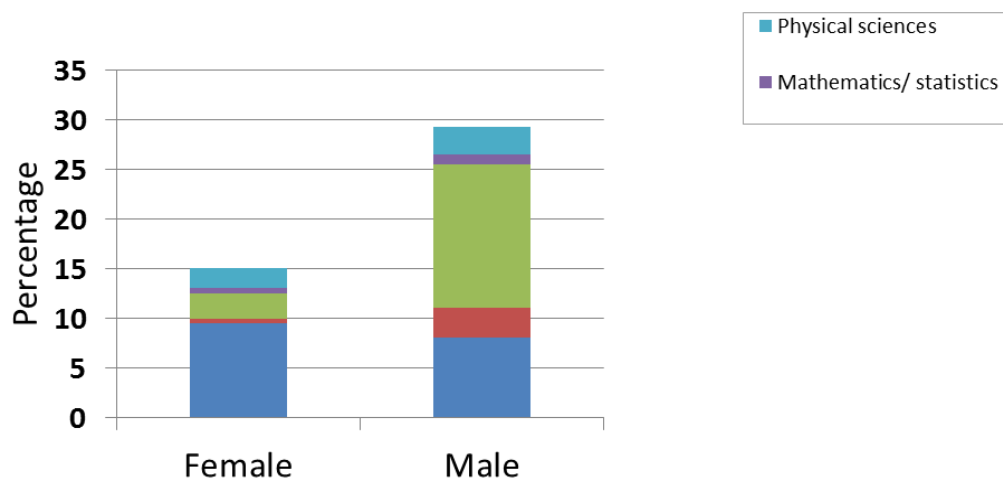

Figure 3. Intent of First-Year College Students to Major in STEM Fields, by Race-Ethnicity and Gender, 2006⁵

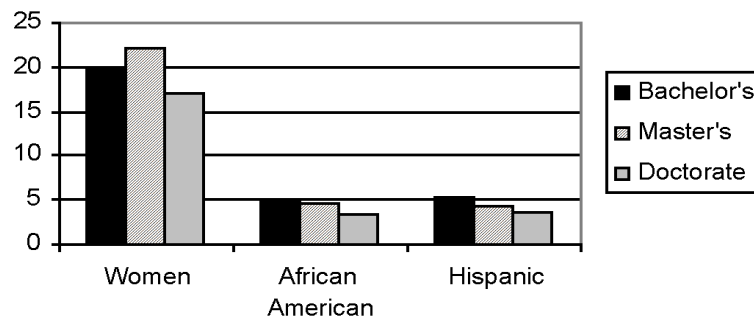

Figure 4. Percentage engineering degrees earned by women, African Americans, and Hispanics in 2003 (source NSF, 2007)

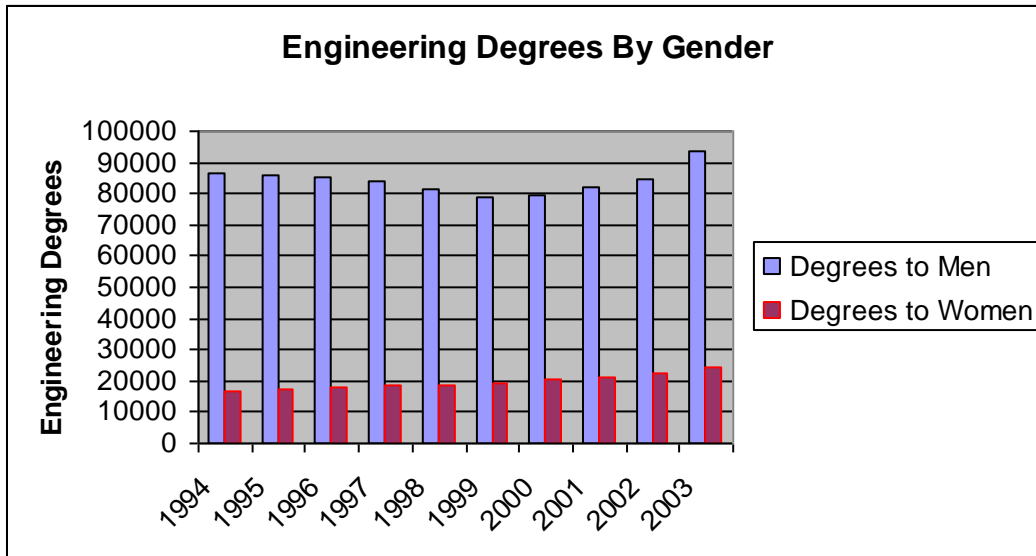

Figure 5. Engineering degrees by gender (Source: Engineering Workforce Commission)

Women in Engineering Workforce

Engineering is still a male dominant career and women in these jobs encounter similar mechanisms related to their minority status as an engineering student, as an engineering faculty or as an engineer working within the private sector. The historically accepted view of technological competence with masculinity is extremely persistent and a result is the slow implementation of change. Stereotype influences the engineering profession's image of engineers, such as engineers being serious and not emotional, unempathetic, and tough on the job. Usually those qualities connected to the engineers are attributed to males while any lacking qualities are attributed to the women⁶. Women don't see pregnancy as a debilitating factor for future hires, a factor men don't have to deal with, but this can be seen as a hindrance to potential employers. Sometimes hostile environments are created so as to limit the successes of women engineers (student, faculty or company engineer). The potential strengths of women for the field of engineering carries positive factors, such as stronger communication skills and a more empathetic, engaging persona. A negating outlook is that women are perceived to have weaker technology skillsets, which makes them ineligible as engineers. Therefore women engineers have to deal not only with regular job pressures, but must attempt to overcome stereotyping as well. In most cases, women engineers end up working longer hours and with less pay than their male counterparts⁷. Their glory is in the merit of their work, one that does not seem fiscally justified.

Industry's view of why few women engineers

Companies often see the main factor for a lower number of female engineers as a dilemma that starts at home. Families, elementary to middle school and universities are where the number of women engineers drops sharply. Some engineering fields have much fewer females than others such as construction engineering. The company view is universities must hire more female role models to recruit more female students so they can hire. Primarily, universities believe companies must provide the role model for students and also competitive salaries to attract more

female students to pursue engineering degrees. Wächter (2005) explains this view as hot potato that is thrown from one responsible party to another (See Figure 6). As if no particular group wants to accept blame or even attempt a reasonable solution.

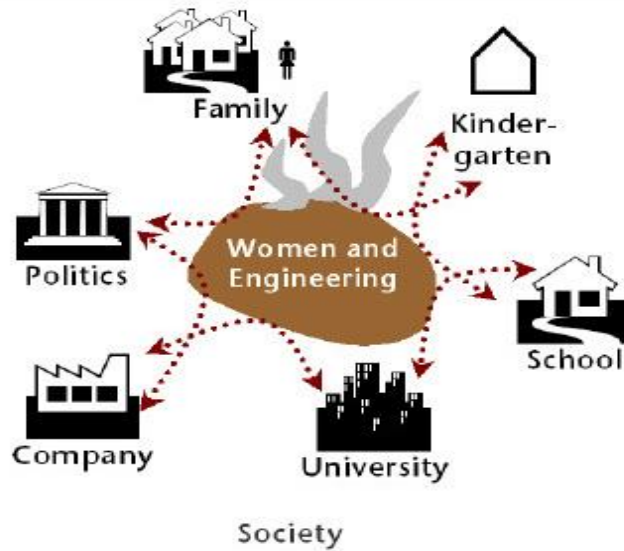

Figure 6. Hot potato model⁸

While the number and proportion of women earning science and engineering graduate degrees has increased dramatically, the need for additional focused steps to increase the representation of women in science and engineering faculties is obvious and persistent. See Figure 7. Universities and colleges play central roles both in the education of scientists and engineers and in the conduct of research and development. Progress towards equality on their campuses is crucial if we are to optimize the productivity of the nation's science and engineering enterprise.

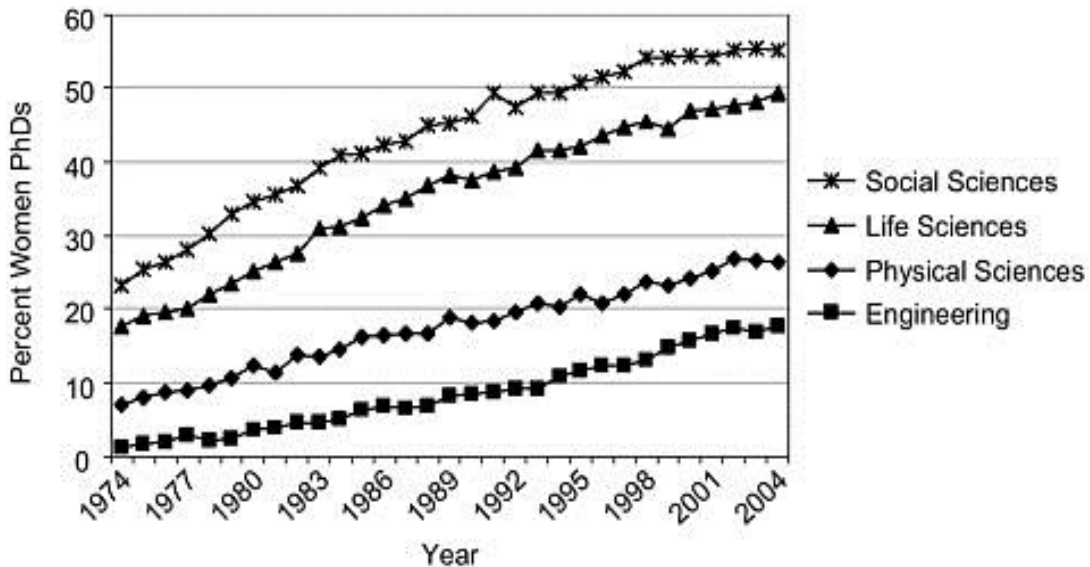

Figure 7. Ph.D Degrees earned by Women, 1974-2004²

Why Women Leave Engineering Careers More Than Other Fields

Preston⁹ reported that all engineers leave the field at a rate of four times that of doctors, three and a half times that of lawyers and judges, and 15-30% more than nurses or college teachers. Specific to engineering, the Society of Women Engineers (SWE) recently reported that one in four women who enter engineering have left the profession after age 30, compared to one in ten male engineers². However, while these studies have documented that women have left the field of engineering, they have not focused on the psychological processes involved in making their decision to leave the profession. Their decision could be related to concerns with work/family balance or lack of advancement opportunities. It could be for several factors, many of which have become the focus of retention studies. Fouad and Singh¹⁰ researched the reasons why women leave engineering careers and their studies showed that despite women comprising more than 20% of engineering school graduates, only 11% of practicing engineers are women. 80% are working full time in another field. After surveying 3,700 women who had graduated with an engineering degree they concluded that the organizational climate was a factor in not entering engineering. The lack of flexibility, a disdain for the culture, and management seemed unappealing. A lack of interest was also cited as a reason not to enter engineering. Around 20% of the women never planned to enter and pursued other post-graduate degrees. Table 1 and 2 summarizes Fouad and Singh's findings on the percentage of women engineers who never enter engineering based on graduation years and what these women are doing now.

Table 1. Percentage of Women who never enter Engineering Based on college graduation year¹⁰

year	Prior to 1993	1984-1989	1990-1994	1995-1999	2000-2004	2005-2010
Percentage	7	13	14	17	24	24

Table 2. Primary Activities of women who never entered engineering workforce (for different years of graduation)

Primary activity	Before 1993	1984-1989	1990-1994	1995-1999	2000-2004	2005-2010	Total
Working on non-engineering Jobs	154	150	42	92	36	2	535
Family care	32	60	42	37	7	3	171
Retired	26	3	0	1	0	0	38
Volunteer	12	3	2	1	0	0	18
Other	18	7	3	7	1	0	36

Furthermore Fouad and Singh's (2011) studies showed that women currently working in engineering did not differ from women who left engineering or never entered the work force on technical knowledge, types of interests, levels of self-confidence and outcomes they expected

from performing in certain tasks. These findings were related to the post-graduate women from engineering colleges. Naturally women were more likely to be committed to the field of engineering if they received opportunities for training and development, opportunities for advancement, and believed that the time demands were reasonable. Women were more likely to be committed to their engineering job when their supervisors and co-workers were more supportive of them overall.

Texas Tech University comparison

As previously discussed, the proportion of women entering many traditionally male-dominated professions has increased substantially in recent years. However, gender ratios in the field of engineering have remained highly unbalanced in the United States, with women constituting only about 20% of engineering majors and holding only about 9% of engineering jobs (National Science Foundation, 2000). Gender balance in engineering is a hot-topic issue in the US and many other countries. The cause of the imbalance has been extensively studied and primarily viewed as a result of the historical patterns of institutionalized gender discrimination, which plays a key role on issues of gender balance in Engineering^{11, 12}. However, there is evidence that achievement-related beliefs are also involved¹³. Texas Tech University College of Engineering shares this gender imbalance in student enrollment as well as the faculty male to female ratio. In Texas Tech University College of Engineering, as seen in Tables 3, 4 and 5 by graduation, men outnumbered women over the last three years. The Graduate degrees held by women are slightly higher given the fact that a majority of the graduate students in the College of Engineering are foreigners. The male faculty to female faculty ratio does not stray too far from the national facts listed in table 6. Of the total number of engineering faculty, only 17 are women.

Table 3. Texas Tech University Degrees Conferred by Gender Years 2009-2010
December 10

College	Gender	Bachelors	Masters	Doctoral	Total
Engineering	Female	63	44	8	115
Engineering	Male	469	168	35	672
Engineering	Not reported	1			1
Engineering	Total	533	212	43	788

Table 4. Texas Tech University Degrees Conferred by Gender Years 2010-2011
December 11

College	Gender	Bachelors	Masters	Doctoral	Total
Engineering	Female	67	45	6	118
Engineering	Male	504	151	37	692
Engineering	Not reported				
Engineering	Total	571	196	43	810

Table 5. Texas Tech University Degrees Conferred by Gender Years 2011-2012
December 12

College	Gender	Bachelors	Masters	Doctoral	Total
Engineering	Female	78	33	8	119
Engineering	Male	569	201	32	802
Engineering	Not reported				
Engineering	Total	647	234	40	921

Table 6. Texas Tech University College of Engineering. Faculty Demographics by departments 2012-2013 (Tenure & Tenure Track)

	Chemical Eng	Civil Eng	Computer science	Construction Eng	Electrical & Computer	Industrial	mechanical	petroleum	Total
Female	3	3	2	1	4	2	4	1	17
Male	12	20	13	7	20	12	29	5	121
Total	15	23	15	8	24	14	33	6	138

Global Demand and need for Gender Balance for Engineers

The demand for engineers is spread across globe. In the United States alone, in the month of September, there were more than 184,000 jobs advertised online for engineering professionals according to Wanted Analytics, a business intelligence firm. The volume of listings was up 12% compared with those a year earlier and 27% against the same time period in 2010¹⁴. Therefore, the role of the academia educating engineers to fill this need is great. We cannot bring a real solution to the problem unless the issue of gender equality is addressed and achieved in a positive manner. The universities role is that of attracting and retaining the female students and more importantly than attracting the female faculty is to provide positive role models for female student. The issue of female faculty is another issue that needs to be addressed. Removing the structural barriers to gender equality in engineering government academic institutions, industry and private corporations as well as global collaborations might be necessary.

Recommendations at Glance:

Education starting early age in the SMET in and out of the classrooms fostered and supported by family and teachers

Mentoring programs for female students in K-12 programs

Encourage students to have more flexible grown mindset about intelligence.

Providing role models to girls very early age

Summer SMET related fun and educational activities for girls

Educate male and female students to be self-confident to break peer pressure issues.

Training school counselors and advisors in gender sensitive issues to be supportive to girls

In Academia: recruit and retain more female students

Provide mentoring and support to female students

Provide scholarships
Facilitate and encourage International exchange opportunities for female students and faculty
Recruit and retain more female faculty,
 Provide female faculty equal startup and support as male counterparts
Provide mentors and networking opportunities
Prevent gender biasness and change negative work climate
Create supportive gender sensitive academic culture

In companies and Organizations: recruit and retain female engineer
Implement gender sensitive recruitment policies
Create clear path toward advancements of women.
Provide in service training
Prevent gender biasness and change negative work climate
Create organizational women friendly culture
Provide mentoring and networking opportunities
Implement Diversity programs will lead to non sexist work culture
Provide family friendly support.
Government, academia and industry collaboration is a necessity.

Conclusions:

It's not just the U.S. that's suffering from a critical shortage of engineers. Many countries are experiencing a decline in the number of young people, especially women, studying engineering. Globalization and new economic development requires including engineers to be functional in more diverse work environments. Given the fact that half of the population is women and most technology related jobs, including engineering, women are seen as minorities is not beneficial. It seems women appear not to play an important role in engineering and technology. However, it is not a deficit of women that provides a gender in balance but rather is the result of biases rooted in stereotypical education systems, teaching and working climate, content, and the context in the engineering fields.

To fulfill global economic needs we need to educate and push more graduating engineers with an emphasis on closing the gap between women and men in engineering fields. There is a big role for government, academia, and the private sector in aiding to fill these gaps and improve upon the enrollment of women into engineering specific careers.

References

1. U.S. Department of Education, N.C.f.E.S., The Nation's Report Card: America's high school graduates. Results from the 2005 NAEP High School Transcript Study by C. Shettle et al. (NCES 2007-467), (Washington, DC: Government Printing Office). 2007.
2. *Society of Women Engineers , Where are all the women going?*
<http://www.societyofwomenengineers.org/regionb/docs/06springnewsletter.pdf>. p.
3. Nord, C., S. Roey, R. Perkins, M. Lyons, N. Lemanski, J. Brown, and J. Schuknecht, *The nation's report card: America's high school graduates (NCES 2011-462)*. Washington, DC: US Department of Education. National Center for Education Statistics, 2011.
4. Hyde, J.S., S.M. Lindberg, M.C. Linn, A.B. Ellis, and C.C. Williams, *Gender similarities characterize math performance*. *Science*, 2008. **321**(5888): p. 494-495.
5. Commission on Professionals in Science and Technology. Data derived from Cooperative Institutional Research Program, H.E.R.I., Graduate School of Education and Information Studies, University of California, Los Angeles, *The American Freshman: National Norms for Fall 1990 through Fall*, www.gseis.ucla.edu/heri/heri.htm, 2006.
6. Thaler, A. *Influence of gender and country-specific differences on success in engineering education*. in *Proceedings of the Fourth European Conference on Gender Equality in Higher Education*. 2005.
7. Wächter, C., *A long and winding road: Women in engineering—An Austrian perspective*. *Teorie Vedy/Theory of Science. Journal for Theory of Science, Technology & Communication*, 2002: p. 5-26.
8. Wächter, C., „*A Gendered Look at Interdisciplinary Engineering Education*”. Yearbook, 2004.
9. Preston, A.E., *Plugging the Leaks in the Scientific Workforce—Much more needs to be done to reverse the high rate of attrition of both men and women early in their scientific careers*. *Issues in Science and Technology*, 2004. **20**(4): p. 69-74.
10. Fouad, N.A. and R. Singh, *WHY WOMEN LEAVE ENGINEERING*.
11. Eccles, J.S., *Where Are All the Women? Gender Differences in Participation in Physical Science and Engineering*. 2007.
12. Heyman, G.D., B. Martyna, and S. Bhatia. *Gender and achievement-related beliefs among engineering students*. in *Journal of Women and Minorities in Science and Engineering*. 2002. Citeseer.
13. Eccles, J.S., *Gender roles and women's achievement-related decisions*. *Psychology of Women Quarterly*, 1987. **11**(2): p. 135-172.
14. Herman Trend Alert: Growing Global Demand For Engineers, D., 2012.
http://www.aftermarketnews.com/Item/107700/herman_trend_alert_growing_global_dem_and_for_engineers.aspx.

From Step-Response to State-Space Controller-Observer Design in Twenty Minutes: A Hands-On Workshop on the Use of Matlab/Simulink to Control a Low-Cost Aerodynamic Pendulum

Eniko T. Enikov, Jesus Acosta Iriqui
Aerospace and Mechanical Engineering Department
University of Arizona

Abstract

This workshop will present broad range of control systems design topics illustrated through the use of a low-cost aeropendulum. The project is based on a USB-powered kit operated by Matlab Simulink environment in real-time. Participants will follow the activities offered to senior-level undergraduate students from mechanical and aerospace engineering majors at the University of Arizona. The project illustrates the entire control systems design cycle from system identification, through analysis and design of dynamic compensators in classical (transfer function based) and modern (state space based) control theory. Advanced topics such as system identification tool box of Matlab, design and testing of an observer/controller pair is also illustrated in an intuitive way suitable for undergraduate students. A summary of the main learning gains is also presented.

The workshop will conclude with a question and answer session as well as individualized experimentation with the portable hardware.

Introduction

Hands-on laboratories are an essential part of the engineering curriculum since its inception. Their importance has been recognized by the Accreditation Board of Engineering Education (ABET) and its predecessors by establishing criteria requiring adequate laboratory practice for students¹⁻⁴. During the last decade, engineering education along with many other fields is moving is experimenting with new delivery methods such as online or distance courses. At the same time experiments have become more complex, including simulation tools and computer controlled test and measurement equipment. This increased sophistication has also led to more expensive equipment^{5,6}.

The inclusion of laboratory courses in the undergraduate curriculum is challenging due to the large number of students and the increased demand for instruction and equipment time. Additionally, online engineering courses are mainly based on pre-recorded video materials and simulations. Therefore hands-on experience, despite its value for active and sensory learning styles⁹⁻¹², is rarely offered in through these new delivery formats. This paper and associated workshop describes the development and testing of a novel take-home laboratory module

designed to supplement the experience of our students taking their first course in Controls System Design.

While there are many turn-key desktop systems designed to illustrate controls systems courses, portable kits, such as Arduino are primarily designed for mechatronics and embedded computing courses^{13,14}. As such, they require programming environments, installation of additional software, and additional plug-in modules for operating DC motors and other actuators. Furthermore, unless one uses advanced circuit boards and processors, implementing a PID or other dynamic compensators is cumbersome and requires training in digital control and programming. With the emergence of the Matlab Simulink graphical programming environment, modeling and simulation of various plants and controllers can be accomplished quite easily by students who might not have extensive training in digital control and numerical methods. However, practical implementation of such controllers remains elusive for most undergraduate students outside of electrical and mechatronics departments. Therefore, the objective of this project was to develop a simple physical plant that can be used seamlessly with the Simulink Real-Time Windows Target environment to allow students who are not in electrical engineering programs to implement and test real-time controllers using drag-and-drop style graphical programming.

The project described here was developed primarily as a way to provide some practical experience to the students using an inexpensive and portable setup which can be taken home. The portability and low-cost of the setup allows them to conduct experiments during the semester and use the device to complete a term project. In addition to significantly reducing the cost of offering an experimental component, the experimental module provided an opportunity to demonstrate a modern approach towards control systems based on computers (digital control).

Description of Hardware Apparatus

The experimental setup consists of a small electric motor driven by a 5 V pulse-width modulated (PWM) signal. The motor is attached to the free end of a light carbon rod, while the other end of the rod is connected to the shaft of a low-friction potentiometer. The potentiometer is fixed on a plastic stand at the proper height, so that the pendulum can swing freely (see Fig. 1). A 2-in propeller (model U-80) is attached to the motor shaft to produce a thrust force in order to control the angular position of the pendulum. The portability of the kit is enhanced by an innovative design allowing the kit to be shipped in a flat 2-in-thick box as shown in Fig. 1(left). A fastener-free design allows the kit to be assembled into its operating condition by interlocking three acrylic plates which interlock when rotated by 45 degrees with respect to the base plate as shown in Figure 1(right). A self-calibrating step during the initialization allows the system to automatically find the vertical position (origin of the coordinate system). A custom designed

Proceedings of the 2013 American Society for Engineering Education Pacific Southwest Conference

Copyright © 2013, American Society for Engineering Education

circuit board produces the controlled voltage supply for the motor via Pulse-Width Modulation (PWM) with a resolution of 0.05 V. It also reads out the voltage on the potentiometer, which is proportional to the angular position of the pendulum. These functions are implemented using a Freescale MC9S08JM16 microcontroller. The apparatus communicates with the controlling computer (PC, Mac, or Linux) using the USB protocol, eliminating the need for the increasingly harder to find serial port. The device is powered by two USB ports, capable of providing a total of 600mA from the host computer. While the motor is capable of producing high rate of revolution in excess of 15,000 rpm, its current consumption is below 500 mA with typical values in the 200-300 mA range. This allows USB-based operation without the need for an external power supply. The microcontroller is commanded to apply various PWM signals to appropriate sides of the H-bridge IC (two P-MOS, two N-MOS) driver depending on the desired direction. When queried, the microprocessor returns the result of several averaged twelve-bit analog to digital conversions to MATLAB, which is then correlated through a proportionality constant to the angle of the pendulum.

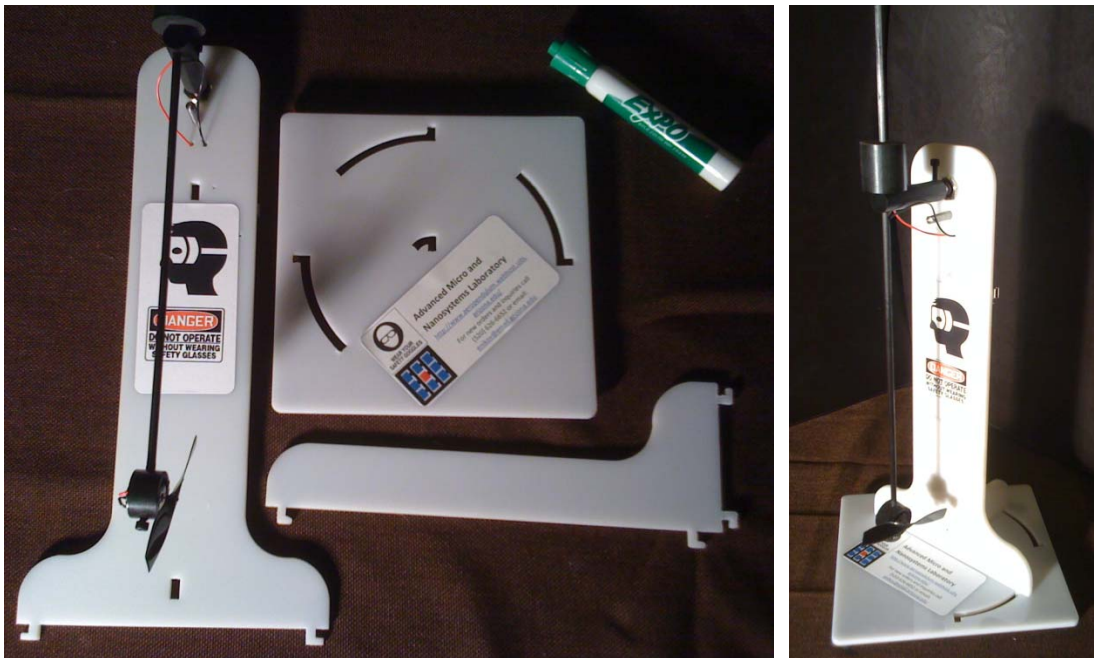

Figure 1. Aeropendulum Kit: Flat Configuration for During Shipping (left); Operating Configuration (right)

Matlab Simulink Control Environment

The aeropendulum control environment can operate in real-time using Matlab/Simulink Real Time Windows Target (RTW) environment (see Fig. 2). The RTW module performs classical control experiments using hardware in the loop simulations. Using RTW, the sampling time was reduced by an order of magnitude to 5 ms. This is achieved by a built-in functionality of RTW that compiles the Simulink model down to C or C++ code, and then builds a native executable

Proceedings of the 2013 American Society for Engineering Education Pacific Southwest Conference

Copyright © 2013, American Society for Engineering Education

fast and negligible for the sake of this step. Most students correctly report an equation of motion given by

$$mL^2\ddot{\theta} = -mgL\sin\theta - c\dot{\theta} + TL, \quad (1)$$

where mg is the weight of the motor, L is the length of the rod, c is the viscous friction coefficient, and T is the thrust force from the propeller (see Fig. 3). The students are instructed to assume a proportionality law between the propeller thrust, T , and the applied motor voltage v

$$T = \kappa v.$$

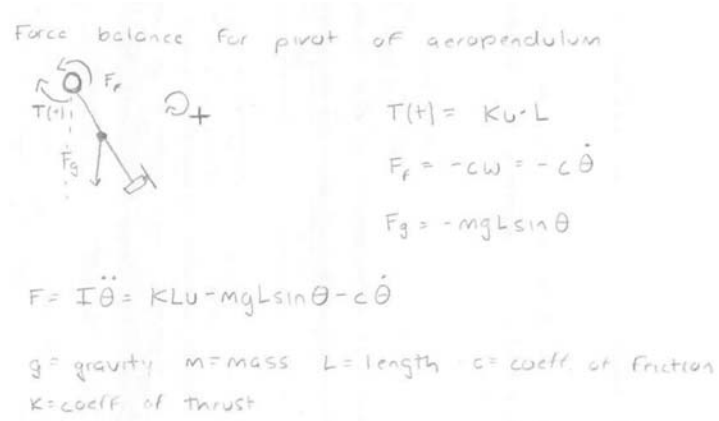

Figure 3. Free Body Diagram (reproduced with permission from student report)

The target board converts these to a motor voltage according to $v = 5u/127$, where the factor 5 is the supply voltage of the USB port. Therefore, the thrust force is proportional to the PWM sent by Matlab RTW module, u

$$T = \kappa v = \kappa \underbrace{\frac{5}{127}}_K u = Ku \quad (2)$$

The second assignment contains an experimental task to examine the steady-state behavior of system (1)-(2) and to determine some of its parameters. To this end, students apply a range of input values $u_{ss} \in [0;127]$ and plot the sine of the steady-state pendulum angle expecting to find a plot representing

$$\sin\theta_{ss} = \frac{K}{mg} u_{ss}.$$

A typical experimental plot is shown in Figure 4. While the plot is quasi-linear, it shows that for small input values, the motor is unable to overcome the static friction and a dead-zone exists in the range $u_{ss} \in [0;20]$

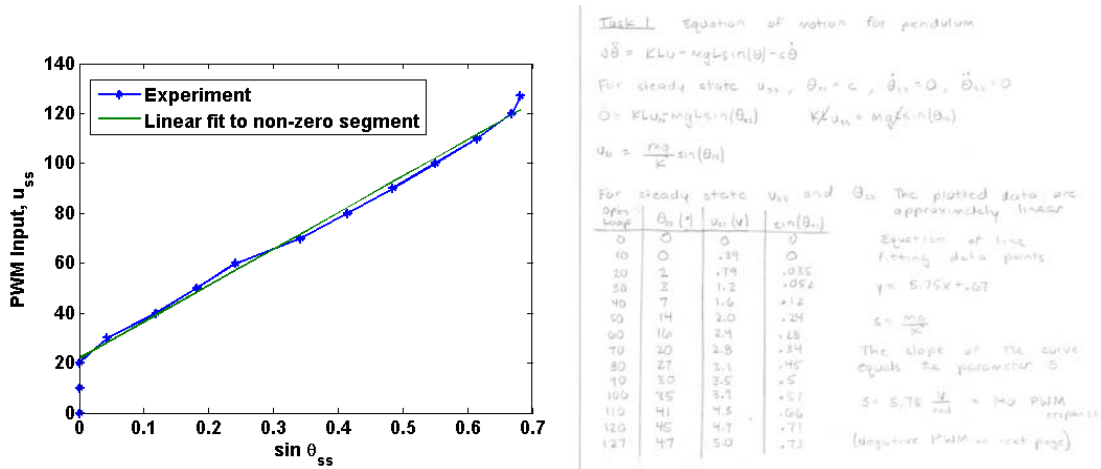

Figure 4. Steady-State Response for Different Inputs Levels (left) and data from student experiment (right)

This presents the first challenge in dealing with real systems. At this stage, students are instructed to use a non-linear law in the form

$$u = \begin{cases} \bar{u} + 20, & \text{if } \bar{u} > 0; \\ \bar{u} - 20, & \text{if } \bar{u} < 0, \end{cases} \quad (3)$$

and to verify that it cancels out the dead-zone in terms of the new input signal \bar{u}

$$mL^2\ddot{\theta} = -mgL\sin\theta - c\dot{\theta} + KL\bar{u}. \quad (4)$$

Upon completion of this task, students are asked to verify that a non-linear feedback law in the form of

$$\bar{u} = \frac{mg}{L} \sin\theta + w \quad (5)$$

will also linearize the plant (4) by cancelling $-mgL\sin\theta$ producing a linear system described by a second order transfer function

$$\frac{\Theta(s)}{W(s)} = \frac{KL}{mL^2s^2 + cs}. \quad (6)$$

Using Simulink RTW environment, it is straightforward to implement the suggested feedback laws (3) and (4) as illustrated in Figure 5. The non-linear element represented by (3) is modeled with a Coulomb and Viscous friction block. Additionally, a saturation element is placed to avoid exceeding the limits of +/- 127.

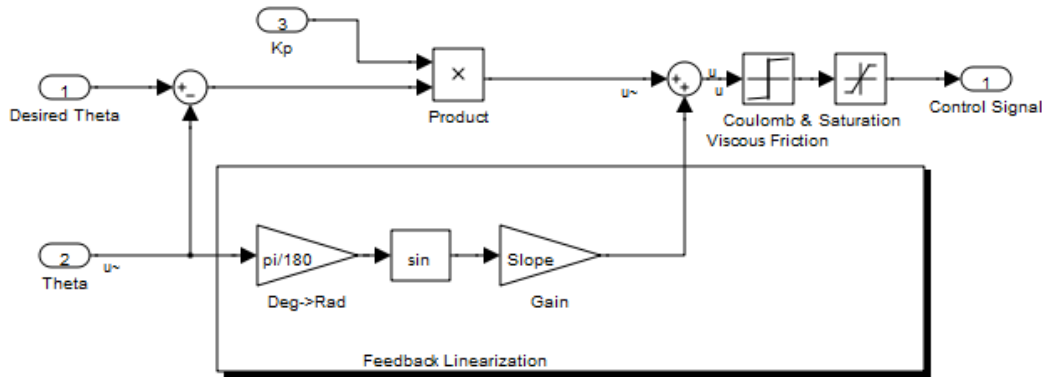

Figure 5. Implementation of Non-Linear Feedback Linearization Laws

In the third installment, students are asked to identify the dynamic characteristics of a unit-feedback system formed from around the plant (6). This task is designed to illustrate the application of the classical formulas describing the natural frequency and damping ratio of a second order system. Since the feedback-linearized system (6) is of type 1, its open-loop step response is unbounded. Therefore, a unit-feedback proportional controller is used to examine the response of the closed loop system as illustrated in Figure 6.

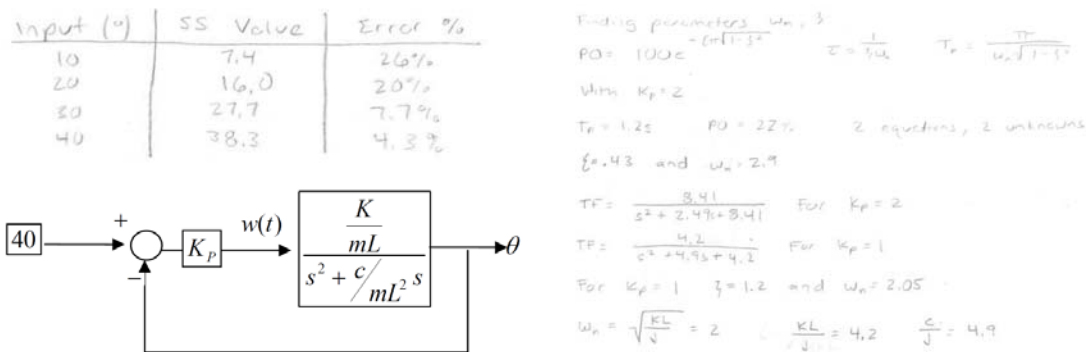

Figure 6. Unit-Feedback Unit-Gain ($K_p=1$) Controller for Plant (6) (left) and student work reproduced with permission (top and right).

Under this task, the students are asked to derive formulas for the natural frequency and damping ratio of the system in Figure 6 for $K_p = 1$ and to obtain values of the model parameters from the step response of the plant through the formulas they have derived

$$\omega_n^2 = \frac{K}{mL}$$

$$2\xi\omega_n = \frac{c}{mL^2}.$$

Upon completion of the initial parameter estimation, students are able to examine the stability predictions of the model by varying the gain K_p . Contrary to what they would expect based on the theory of second order systems, the plan has a critical gain $K_p^* \approx 3$, beyond which the system loses its stability as illustrated in Figure 7.

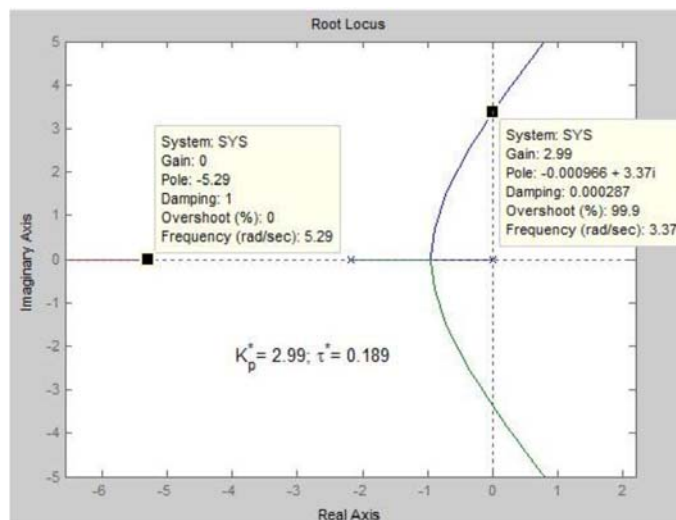

Figure 7. Root locus of a third order system with critical gain $K_p=3$.

The observed instability is easy to explain when considering the dynamics of the motor-rotor sub-system. The motor represents an additional second-order system for two additional state variables (current and rate of rotation). To improve the model accuracy, after a class discussion, students are encouraged to add a third pole at $-1/T_D$ representing the time constant of the rotor. By adjusting the value of T_D , such that the critical gain of the model coincides with the experimentally observed one, students are able to extract an estimate for $T_D \approx 0.189$.

After the addition of the third pole, the model is further refined to take into considerations inaccuracies in the feedback linearization. The most apparent one is a steady-state error of approximately 15-25% (5-8 degrees) depending on the accuracy of the parameter estimation. To this end, we ask the students to correct the model by adding a small parameter b , which has the effect of changing the type from 1 to zero. The corresponding plant is shown in Figure 8.

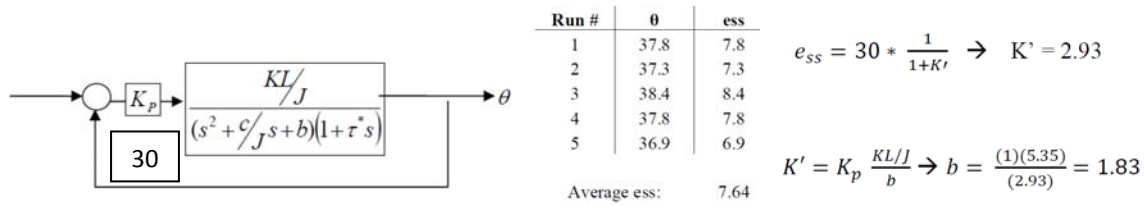

Figure 8. Third-order pendulum model with of type 0 (left) and experimental determination of paratmer b (right).

Finally, the students have a reasonably accurate model which allows them to carry out dynamic compensator design. In their final project installment, they are asked to design a lag compensator in the form

$$C_{lag} = \frac{s + z}{s + p}, \quad z > p > 0$$

with the goal of reducing the steady-state error caused by the imperfect feedback linearization to below 1 degree (5%). This requirement leads to a requirement to increase the DC gain by a factor of 5. Therefore, the lag controller with $z = 5p$ is selected. The only remaining parameter to tune is the value of p , which students select using either root locus or Bode plot design methods. Prior to testing, the lag controller has to be converted to z-domain using a command mode continuous to discrete transformation command $c2d$, which is part of the Control Systems Toolbox, ($Clagd=c2d(Clag,0.01,'zoh')$). The newly defined $Clagd$ is referenced by the Lag Controller block of the Simulink RTW model. To activate input from this block, students also need to set the input selector value to 3 (see Fig. 2). The resulting response of the plant is shown in Figure 9, where two manually induced disturbances are also visible. As anticipated, the steady-state error is below 1 degree and it can be noticed that the integrator term reduces the error over approximately 20-second period which matches the time constant of the pole $p=0.05$. In a similar way, the students can design and implement lead, lead-lag, and notch compensators of any order.

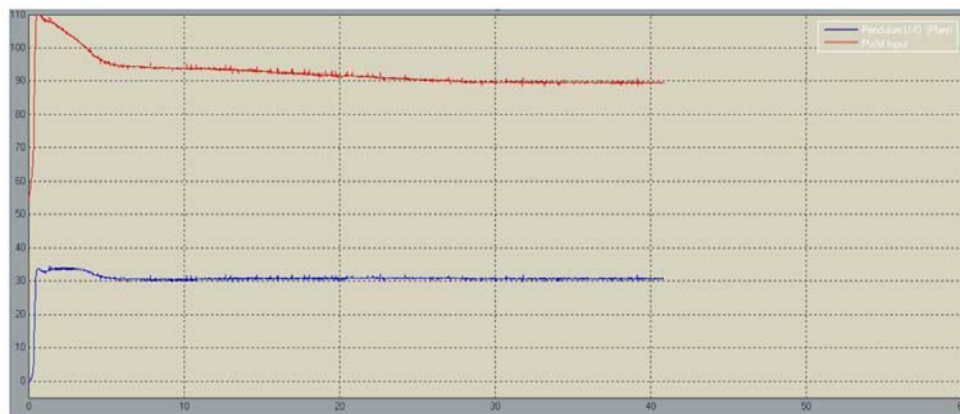

Figure 9. Aeropendulum Step Response to a Reference Input of 30 with a Lag Compensator $z=0.25, p=0.05$.

Modern Control (State-Space Design Method) and Advanced Topics

In a typical introductory course in control systems design, modern control (state-space description), is considered an advanced topic. Nevertheless, due to the simple nature of the developed system and its compatibility with Matlab, it is possible to illustrate the key features of modern control design including the construction of an estimator. To this end, the feedback linearized pendulum is introduced as a linear plan described by the state-space matrixes **A**, **B**, **C**, and **D** (see Fig. 10). The actual values of coefficients of these matrixes can be extracted using a single experiment analyzed with *pem* function of the Matlab System Identification Toolbox.

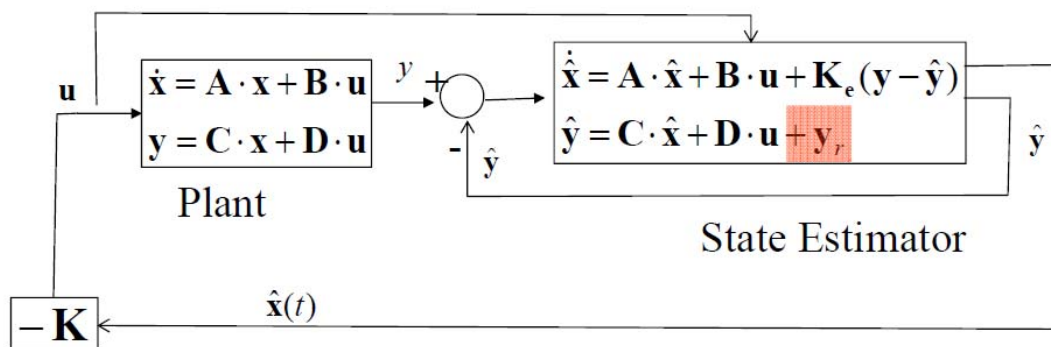

Figure 10. State Space Description of Pendulum (Plan) and State Estimator

Using a single experiment carried out under unit-feedback mode ($K_p = 1$ and controller select set to 2, Fig. 2) followed by the Matlab command mode script in Figure 11, the closed loop transfer state space matrixes CL.A, CL.B, CL.C, and CL.D can be extracted. Upon conversion to an equivalent transfer function gCL, one can use simulate the system and compare the responses between the estimated and actual plants (see Fig. 12)

```
DAT = iddata(theta,theta0,0.01);
m1 = pem(DAT, 'p2u')
CL=idss(m1);
[n1 d1]=ss2tf(CL.A,CL.B,CL.C,CL.D,1)
gCL=tf(n1,d1)
[y1,t1]=lsim(gCL,theta0,t);
plot(t,theta,t1,y1)
gOL=feedback(gCL,1,+1)
Sys=ss(gOL);
```

Figure 11. Matlab Parameter Identification Script

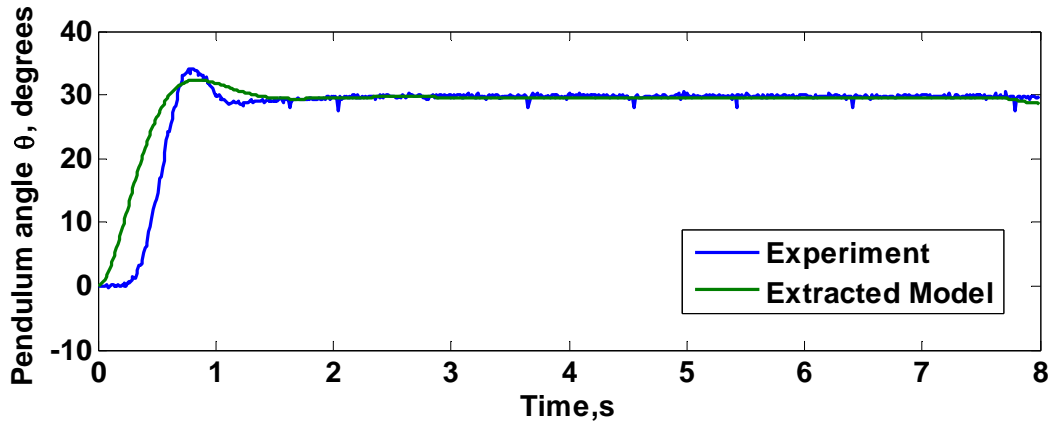

Figure 12. Extracted Model Response vs. Experiment

Subsequently, the open loop transfer function and the associated **A**, **B**, **C**, and **D** matrixes can be obtained. The script in Figure 13, demonstrates pole placement method using the Ackerman formula for the state feedback matrix **K** and the estimator feedback matrix **Ke**. The poles were placed at $-4+j$ and $-4-1*j$ respectively. The code also generates a controller using the estimator matrixes and transfers it into a discrete controller `clead`, which is programmed into the Simulink block Lead Controller (selector value 3 in Fig. 2).

```
K=acker(Sys.a,Sys.b,[-4+1*j -4-1*j])
Ke=acker(Sys.a',Sys.c',[-40+2*j -40-2*j])'
Ae=Sys.a-Sys.b*K-Ke*Sys.c+Ke*Sys.d*K
Be=Ke
Ce=K
[nh dh]=ss2tf(Ae,Be,Ce,0)
H=tf(nh,dh)
stepplot(30*H*gOL/(1+H*gOL),[0:0.01:10])
hold
stepplot(30*H/(1+H*gOL),[0:0.01:10])
legend('Output with Lead','Control Effort (Input)')
shg
clead=c2d(H,0.01)
```

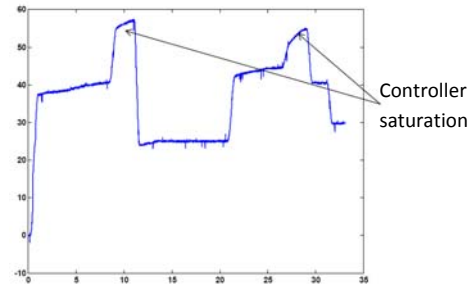

Figure 13. Matlab Script for Pole Placement using State Space Description (left) and Pendulum Response (right).

Operating the pendulum with the state-space controller demonstrates a much faster response, albeit less accurate (see Fig. 13 – right). At high values of the reference input, controller saturation leads to a slower response.

Project Evaluation

During the 2008-2011 academic years, the project was offered several times to three different cohorts and by different instructors. The impact of the project was assessed through student surveys conducted at the end of the course following the protocol approved by the Institutional

Review Board. Additional data were drawn from student reports. The data reported here (see Table 1) are from a section not taught by any of the authors; instead the instructional materials and hardware were provided to a different instructor and his teaching assistant. However, the results from surveying the authors' sections agree to within 5%-8% in most categories of the data shown here. As part of the evaluation, students were asked questions about the technical content, as well as the implementation and impact of the portable experiment. The highest benefits are derived from better understanding of the relationships between stability and gain, the importance of transfer functions in capturing the physical models, followed by the ability to deal with non-linear systems and time delay. Interestingly, the highest gains (average rating of 3.32 in Table 1) were achieved in understanding of the relationship of stability and gain. When asked to comment on the discrepancy observed between the theory and experiment in a homework-style assignment, 33% of the students correctly identified the missing rotor dynamics as a possible cause, while 56% felt that the feedback linearization somehow masked the unstable modes or was imperfect, leading to loss of stability. Another 11% looked for physical limitations in the system or faulty components. It appears that the large number of misconceptions paired with challenging the students' confidence in their ability to model the plant, along with providing a plausible solution to the problem, could explain the highest gains in this category. Further case studies would be required to confirm this observation. Among the least understood topics was the use of Bode plots, perhaps due to the fact that it was covered at the very end of the semester, leaving little time for practice and exploration.

The portability and convenience of the implementation of the experiment was evaluated through a second set of questions, where 42.9% of the students reported that they did not need a permanent lab and another 42.9% had to use a teaching assistant consultation for not more than 1 hour. Only 3.6% of the respondents to this question indicated that more consultation was needed,

Table 1 Student Feedback Data

To what extent (how well) did the project illustrate the following technical concepts?					
	Not at all	Less than expected	More than expected	Very Well	Rating Average*
Relationship between physical system and transfer function	0.0% (0)	7.1%(2)	64.3%(18)	28.6%(8)	3.21
Second-order system response	3.6% (1)	10.7%(3)	60.7%(17)	25.0%(7)	3.07
Relationship between stability and gain	0.0% (0)	10.7%(3)	46.4%(13)	42.9%(12)	3.32
Relationship between overshoot and gain	3.6% (1)	25.0%(7)	35.7%(10)	35.7%(10)	3.04
Use of root locus	0.0% (0)	17.9%(5)	57.1%(16)	25.0%(7)	3.07
Use of Bode plots	14.3% (4)	39.3%(11)	35.7%(10)	10.7%(3)	2.43
System type and steady state error	7.1% (2)	10.7%(3)	50.0%(14)	32.1%(9)	3.07
Disturbance rejection and system recovery	7.4% (2)	11.1%(3)	48.1%(13)	33.3%(9)	3.07
Non-linearities and ways to deal with them	0.0% (0)	14.3%(4)	60.7%(17)	25.0%(7)	3.11
Effects of time delay	0.0% (0)	17.9%(5)	53.6%(15)	28.6%(8)	3.11

* Point scale: 1 - Not at all, 2- Less than expected, 3- More than expected, 4- Very well

while 10.7% wanted to have a permanent lab space dedicated to the project. The average duration for completion of the project was 7.78 hours.

Conclusions

An inexpensive portable experimental setup has been described for use as a hands-on experience for undergraduate students taking senior-level classical control system design courses. The project requires minimal or no supervision without the need for a specialized laboratory space. In 10 out of 11 topics, students self-reported above average learning gains. Highest gains were achieved through a problem that challenges the student's trust and beliefs in the theory when confronted with an apparent contradiction with experimental observations. Presenting the project as a series of short assignments allows the instructor to provide guidance to the students without sacrificing the ability to encourage individual experimentation. The project is particularly aimed at students whose major is not electrical engineering becoming familiar with the modern developments in implementation of real-time control systems. While simple, the hardware allows demonstration of advanced concepts such as feedback linearization. Evaluation data show that the project is well-received among students and it can be completed independently over an average of 8 hours. Parameter variation through modification of the configuration of the pendulum allows the instructor to individualize each kit.

Acknowledgments

This work was supported by NSF Grants 0927661, 0633312, and FIPSE Grant #P116J080016 from the US Department of Education.

Bibliography

- [1] Commission on Engineering Education, "New directions in laboratory instruction for engineering students," *Journal of Engineering Education*, vol. 58, no. 3, pp. 191--195, 1967.
- [2] American Society of Engineering Education, *The Undergraduate Engineering Laboratory: Final Report of the Quality of Engineering Education Project (QEEP)*, 1986.
- [3] Engineering Foundation (U.S.). Conference (1983 Jul. 24-29 : Henniker, N.H.), *The Undergraduate Engineering Laboratory*, E. W. Ernst, Ed., 1983.
- [4] ABET, *Engineering Criteria 2000*, 2002.
- [5] M. Aburdene and M. El-Sharkawy, "Integrated engineering workstations in electrical engineering laboratories," *IEEE Transactions on Education*, vol. E-32, pp. 404--408, 1989.
- [6] J. Kadowec, P. Lockette, E. Constans, B. Sukumaran, and G. Cleary, "Visual beams: tools for statics and solid mechanics," in *Proceedings of the 32-nd ASEE/IEEE Frontiers in Education Conference*, vol. T4D, Boston, November 2002, pp. 7--10.
- [7] P. Horàcek, "Laboratory experiments for control theory courses: A survey," *Annual Reviews in Control*, vol. 24, pp. 151--162, 2000.

Proceedings of the 2013 American Society for Engineering Education Pacific Southwest Conference
Copyright © 2013, American Society for Engineering Education

- [8] R. V. de Molengraft, R. Steinbuch, and B. Kraker, "Integrating experimentation into control courses," *IEEE Control Systems Magazine*, vol. 25, no. 1, pp. 40--44, 2005.
- [9] R. M. Felder, "Reaching the second tier-learning and teaching styles in college science education," *Journal of College Science Teaching*, vol. 23, no. 5, pp. 286--290, 1993.
- [10] R. Dunn, "Learning styles and its relation to exceptionality at both ends of the spectrum," *Exceptional Children*, vol. 49, pp. 496--506, 1983.
- [11] S. Papert, *Mindstorms: Children, Computers, and Powerful Ideas*. New York: Basic Books, 1980.
- [12] I. Harel and S. Papert, *Constructionism*. Norwood, NJ: Ablex Publishing, 1991. [Online]. Available:<http://www.amazon.com/exec/obidos/redirect?tag=citeulike07-20&path=ASIN/0893917850>
- [13] J. Sarik and I. Kymissis, "Lab kits using the arduino prototyping platform," in *Frontiers in Education Conference (FIE)*, 2010 IEEE, oct. 2010, pp. T3C--1 --T3C--5.
- [14] P. J. Gawthrop and E. McGookin, "A lego-based control experiment," *IEEE Control Systems Magazine*, vol. 24, no. 5, pp. 43--56, 2004.
- [15] E. T. Enikov, "Aeropendulum project," 2011. [Online]. Available: <http://aeropendulum.arizona.edu/>

Project-Based Innovation and Entrepreneurship Education in Engineering

R. Radharamanan
Mercer University, Macon, GA 31207

Abstract

This paper highlights project-based innovation and entrepreneurship education activities developed and implemented at Mercer University School of Engineering (MUSE). MUSE promotes entrepreneurial mindset among engineering students through curriculum development, extracurricular activities, and involvement of students in the entrepreneurship program. It has developed and implemented a course sequence to integrate elements of entrepreneurship in engineering courses; develop an entrepreneurial mindset in engineering students; foster innovation and creativity in engineering disciplines; help the students to develop business plans for the entrepreneurial design projects and compete in the annual business plan competition, and promote new ventures creation. The expansion of this program will support educational interdisciplinary curricula and co-curricular activities and benefit the students providing multi- and cross-disciplinary teaching, learning, and research opportunities on innovation and entrepreneurship. Selected creative student design projects with business plans involving CAD/CAM, Robotics, and Rapid Prototyping are presented, analyzed, and discussed. The students learning outcomes and their professional skills are assessed using KEEN-TTI's survey of engineering students. From the sample data analyzed, the students improved and/or mastered 19 of the 23 professional skills by the senior year, but lack mastery of skills in Conflict Management, Creativity/Innovation, Persuasion, and Empathy. Incoming freshmen profile consists of more males than females with poor Problem-Solving skills. The results obtained from the sample data analyzed are presented and discussed.

Introduction

The field of entrepreneurship has been defined as the “study of the sources of opportunities; the process of discovery, evaluation, and exploitation of opportunities”¹. The entrepreneur has been described as “an innovator or developer who recognizes and seizes opportunities, converts these opportunities into workable and/or marketable ideas”². The importance of entrepreneurship education has been emphasized in business schools and recently in some of the engineering schools. There is a growing need to enhance the entrepreneurship education in universities and colleges due to globalization and emerging international competitions³. The educational system at the university level at present is not capable of developing students' motivation, competences and skills concerning innovation and entrepreneurship. Instead, entrepreneurship education requires learning methods, pedagogical processes and framework for education, which universities at the moment have not mastered. Such changes, however, involve parallel transformations of didactics, pedagogy and university context⁴. Design for manufacture and assembly and concurrent engineering concepts have been addressed in technology ventures and engineering entrepreneurship education⁵⁻⁷. Creation of academic ventures and business incubation has received increased attention lately⁸⁻¹⁰.

With the changing role of universities, the role of academics has also changed. From being more likely to have the role of advisors, facilitating the transfer of knowledge to the new venture, they are today more likely to be members of the entrepreneurial team, thus playing a greater role in identifying and developing the entrepreneurial opportunities, acquiring resources, and organizing the venture¹¹.

Entrepreneurial education must include skill building courses in negotiation, leadership, new product development, creative thinking and exposure to new technological innovation¹². Technology must be embraced within the classrooms. Solomon, Duffy and Tarabishy¹³ conducted one of the most comprehensive empirical analyses on entrepreneurship education. In their view of entrepreneurship pedagogy, they stated, “A core objective of entrepreneurship education is that it differentiates from typical business education. Clearly, for entrepreneurship education to embrace the 21st century, professors must become more competent in the use of academic technology and also expand their pedagogies to include new and innovative approaches to the teaching of entrepreneurship”.

Since 2006 KEEN (Kern Entrepreneurship Education Network) schools are preparing more entrepreneurial engineers in the United States¹⁴. There are more than 20 KEEN schools that share the same vision to instill entrepreneurial mindset into engineering undergraduates. MUSE, one of the KEEN schools, has recently established the Mercer Center for Innovation and Entrepreneurship (MCIE) to promote entrepreneurship education at Mercer campus and collaborate with other KEEN schools in the areas of common interest that include but not limited to: low cost rapid prototyping, smart product design, assistive technologies, alternate energy technologies, and integration of engineering and general education.

Mercer Engineering Entrepreneurship Education Program (MEEEP)¹⁵

The purpose of Mercer University’s School of Engineering is to educate a student who is prepared to be practicing engineer, one who can responsibly contribute to a global society that is becoming ever more dependent on technology. While the focus of the engineering school is to educate engineers, its graduates may enter many fields of graduate studies, especially those requiring the disciplined problem solving methods developed in the undergraduate curriculum. The engineering graduates have entered professional graduate programs in medicine, law, and business, as well as graduate engineering programs. There are 420 undergraduate and 150 graduate students at Mercer School of Engineering. The ABET accredited undergraduate program has biomedical, computer, electrical, environmental, industrial, and mechanical engineering specializations. There are 28 engineering faculty engaged in teaching undergraduate and graduate programs.

The entrepreneurship certificate program was established through Kern Family Foundation Grants in 2007. This program is open to all engineering students at MUSE. Students who complete the course requirements will receive a Certificate of Achievement in Engineering Entrepreneurship. The entrepreneurship certificate program requires completion of the following courses:

ECN 150: Principles of Microeconomics (3-0-3) (optional)

Prerequisite: Mathematics competency or completion of a college mathematics course.

A study of the basic tools of economic analysis and the principles necessary to appreciate economic relationships, business behavior, and consumer behavior. Special emphasis will be given to the areas of supply and demand, marginal analysis, and the theory of the firm.

MKT 361: Principles of Marketing (3-0-3)

Prerequisite: Sophomore standing

Role of the marketing function in planning and implementing objectives of the firm. Consumer markets, industrial markets, channels of distribution, product and pricing policies, sales forecasting, promotion, and control.

MGT 363: Principles of Management (3-0-3)

Prerequisite: Sophomore standing.

This course provides an overview of organizational behavior in business. Students are introduced to the theory and practice for individual, group, and organizational influences on human behavior in relation to management in organizations. Specific topics include perception, personality, motivation, job satisfaction, teamwork, conflict resolution and communication processes. The topics are treated at the individual, group, and organization level to prepare students for the challenges of management.

MGT 427: Entrepreneurship (3-0-3)

Prerequisites: MGT 363 and MKT 361.

An entrepreneur is someone who undertakes a venture, organizes it, raises capital to finance it, and assumes all or a major portion of the risk. This course typically covers profiles of entrepreneurs, means of going into business, venture opportunities, and the financial aspects of becoming an entrepreneur. Extensive case studies and projects are required. Each student also develops a business plan.

ISE 480: Introduction to Senior Design (0-1-0)

Prerequisite or Co-requisites: Junior Standing

Course will provide guidance for the selection of team members and topic for the senior design project to be completed in EGR 487 and EGR 488. To successfully complete the course, a student must belong to a team (3 to 4 persons) and briefly outline the project goals to be implemented in EGR 487 and EGR 488. A seminar series will be conducted to facilitate student introduction to potential industrial clients and projects. Seminar attendance is required to obtain a satisfactory course grade. This course is graded S/U.

EGR 482: Engineering Innovation and Creativity (3-0-3)

Pre-requisites: Senior Standing

Introduction to innovation and creativity; elements of entrepreneurship, entrepreneurial process and creation of new products; venture opportunities and venture creation; evaluating alternatives and project assessment; business plan; leadership; entrepreneurial manager; finance, venture, and growth capital; third party assessment; managing rapid growth; discussion on case studies and business plans. Students will develop business plans associated with their senior design projects.

EGR 487: Engineering Design Exhibit I (0-6-2)

Prerequisites: Senior Standing and EGR 480. Must have completed all required 100- and 200-level engineering, mathematics, and science courses.

Multi-disciplinary design projects with substantial engineering content. Small groups design, build, and test realistic engineering systems under faculty supervision. Projects include safety, economic, environmental, and ethical considerations and require written and oral reports.

EGR 483: Entrepreneurship in Engineering Design (0-1-0)

Pre-requisites: EGR 482 and EGR 487

Student seminars and advising for assessment of business plans related to entrepreneurship and innovation in an engineering design project; participation in seminars, competitions or regional and national conferences. Seminar attendance is required to obtain a satisfactory course grade. This course is graded S/U.

EGR 488: Engineering Design Exhibit II (0-6-2)

Prerequisite: EGR 487.

Continuation of EGR 487 multi-disciplinary design projects with substantial engineering content. Small groups design, build, and test realistic engineering systems under faculty supervision. Projects include safety, economic, environmental, and ethical considerations and require written and oral reports.

Table 1 shows the courses taken by semester to complete the certificate program in entrepreneurship. The catalog description of the entrepreneurship certificate program courses are also found in Mercer University Catalog¹⁶.

Table 1. Courses taken by semester

Sophomore-1	Sophomore-2	Junior-1	Junior-2	Senior-1	Senior-2
			EGR 480	EGR 487	EGR 488
			MGT 427	EGR 482	EGR 483
	(ECN 150)	MKT 361			
		MGT 363			

1: Fall semester; 2: Spring semester.

In addition to the certificate program courses, course modules on creativity, invention, innovation, and entrepreneurship have been developed and taught in the following freshman through senior level courses: EGR 107: Introduction to Engineering Design; MAE 205: Visualization and Graphics; EGR 245: Electrical Engineering Fundamentals; ISE 370: Manufacturing Processes; MAE 305L: Manufacturing Practices Lab; ISE 425: Computer Assisted Manufacturing Systems & Lab; ISE 429: Robotics; BME 412: Biomechanics; and BME 413: Advanced Biomechanics. The MEEEP courses and course modules developed and offered across the curriculum from freshman through senior year helps to instill entrepreneurial mindset to students graduating from MUSE.

Since 2007, all engineering students took one or more courses and/or modules listed in the entrepreneurship certificate program; 25 entrepreneurial senior design projects were funded; 100 or more students participated in the business plan/entrepreneurial senior design project

competitions; one of the projects received national and state recognition; ten projects received regional/Mercer awards; more than 40 papers were presented in regional, national, and international conferences by faculty and students; students and faculty applied for 5 provisional patents and 2 utility patents; students and faculty are in the process of forming at least two startup companies focusing on low cost electromechanical and biomedical devices; and more than 25 students are working as intrapreneurs in major industries/corporations in Georgia and neighboring states.

Mercer Center for Innovation and Entrepreneurship (MCIE)

In 2010, Mercer's Academic Initiatives Monetary Fund (AIM Fund) has approved the creation of the "Mercer Center for Innovation and Entrepreneurship" at MUSE, to enhance the activities of MEEEP across Mercer campus. The center is operating since August 2010. The MCIE focuses on cross-disciplinary educational programs (teaching, collaboration, and learning) as well as research and scholarly activities among Mercer faculty and students. This unique center initially involves the School of Engineering, School of Medicine, School of Law, School of Business and Economics, and College of Liberal Arts. Possible future participation is envisioned from other colleges and schools such as College of Nursing, College of Pharmacy and Health Sciences, School of Theology, and School of Music. The MCIE provides an interdisciplinary collaboration that is necessary for submitting competitive extramural funding proposals. It serves as a platform for diverse scholarly activities, curricular and co-curricular enhancements.

On August 20, 2010, the MCIE and MEEEP organized a workshop for the entire engineering faculty on "entrepreneurial education through case studies." The workshop had sessions on (1) entrepreneurial thinking/entrepreneurial mindset (2) importance of entrepreneurship in engineering education (3) role of engineering faculty and faculty development and (4) team work on entrepreneurial thinking and case study. All 28 engineering faculty participated in the workshop.

During September 16-17, 2010, KEEN Regional Conference on Innovation and Entrepreneurship was hosted by the MCIE and MEEEP at the Mercer University School of Engineering. The overall objective of the conference was to bring together faculty and students from KEEN schools on a common platform and discuss about the progress made in each KEEN school in the areas of invention, innovation and entrepreneurship through faculty and student presentations and promote future collaboration among participating KEEN schools: (1) initiate collaboration in teaching, senior design projects, and exchange of faculty and students; (2) identify directions for future regional conferences; (3) promote faculty and students interactions; and (4) explore submitting joint proposals to funding agencies.

Faculty, staff and students from eight KEEN Schools (Baylor University, Calvin College, Illinois Institute of Technology, Lawrence Technological University, Mercer University, Milwaukee School of Engineering, Saint Louis University, and University of Detroit Mercy) participated and presented their projects and research work on invention, innovation, and entrepreneurship and discussed possible collaboration among KEEN schools and future direction for the KEEN regional conferences. More than a hundred faculty, students, administrators, and industry personnel participated in the regional conference.

The KEEN Second Regional Conference on Innovation and Entrepreneurship Education was hosted and held at Mercer University Campus, Macon, GA during March 15-17, 2012. The objective of this meeting is to bring together administrators, faculty, students, and staff from KEEN Schools on a common platform to discuss about the Innovation and Entrepreneurship Education at KEEN Schools as well as possible collaboration between them on topics of common interest that include but not limited to:

- Entrepreneurially-minded Education and Culture
- Intrapreneurship Education
- Entrepreneurial Project-based Education
- Collaboration within and between Dense Networks
- Integration of Engineering and General Education
- Entrepreneurial Engineering and Enterprise
- Web-based Entrepreneurial Education between KEEN Schools
- KEEN/ABET Assessment
- Long-term Sustainability of Entrepreneurship Education
- Students' Project/Poster Presentations & Product Demonstrations
- Testimonial Presentations from Student Teams on KEEN Initiatives

Faculty, staff and students from seven KEEN Schools (Gonzaga University, Kettering University, Lawrence Technological University, Mercer University, Milwaukee School of Engineering, Saint Louis University, and University of Evansville) and members of Eureka, NFP, and representatives from Kern Family Foundation participated and presented their papers, projects and research work on invention, innovation, and entrepreneurship and discussed possible collaboration within and between KEEN Dense Networks in teaching, design projects, and exchange of faculty and students. The conference also had sessions on “Integration of Engineering and General Education”, “Assessment of KEEN Student Outcomes”, “Student Design Project/Poster Presentations and Product Demonstrations”, “Student Testimonial Presentations Highlighting Impact of KEEN Initiatives on Engineering Education and Student Learning” and “Future Direction for the KEEN Regional Conferences”. More than a hundred faculty, students, administrators, and industry personnel participated in the regional conference.

In addition, a low cost 3-D scanning/printing facility (Figure 1) has been added to the MCIE to enhance innovation and creativity aspects among engineering students as well as to instill entrepreneurial mindset that includes making prototypes of their design products as well as learning to commercialize the products they made. During the fall semester (2011) more than 50 seniors, juniors, freshman, and honors students were trained to scan 3D objects as well as design and print 3D parts/products in the new facility. During the spring and fall semesters of 2012 more than 100 students were trained in this facility that include honors students/projects, senior design projects, class projects and special projects. Another 3-D printer has been added to the facility to meet the growing need for the rapid prototyping and 3-D printing needs of Mercer engineering students to successfully complete their innovative open ended design projects.



3D scanning/printing

Sample parts printed

Samples for testing

Figure 1. 3D scanning/printing facility and parts printed

Mercer Entrepreneurship Student Club

Mercer Entrepreneurship Student Club (MESCC) started in 2007, as part of MEEEP to promote students activities on innovation and entrepreneurship across Mercer campus. More than 60 engineering students through MESCC are actively engaged in: recruiting students to the entrepreneurship program; participating in the entrepreneurship certificate program; taking entrepreneurship related courses; participating in entrepreneurial senior design projects, listening to successful entrepreneurs through invited speakers and seminar; developing business plans and competing in the design and business plan competitions; promoting activities during national entrepreneurship week; raising funds to participate and present technical papers on their senior design and business plans through “Cookout” lunches and dinners and selling T-shirts that were designed and made by entrepreneurship club students; presenting technical papers in the national and international conferences; and actively participating in the activities of MCIE:

1. Participated in the KEEN Regional Conference on Innovation and Entrepreneurship, held at Mercer University School of Engineering during September 16-17, 2010 and interacted with the faculty and students from other KEEN schools; sixty Mercer students participated in the conference; fifteen students (5 student teams) presented their entrepreneurial design projects in the student paper/poster and product demonstration competition and one student team got the 2 place and cash award.
2. Promoted and organized Annual Mercer Innovation Chase Competitions (March 18-20, 2011); eighteen students (five student teams) participated in the competition; the winning team was sent to Chicago Innovation Chase Competition (September 8-11, 2011).
3. Twelve students (5 student teams) participated in the Ford-UDM online innovation competition during September-November 2011.
4. Promoted and helped to organize the KEEN Second Regional Conference on Innovation and Entrepreneurship Education held at Mercer Campus during March 15-17, 2012. Twenty four Mercer students (eight student teams) presented and competed in the design projects competition. One student team got the 3 place and cash award.
5. Promoted and organized spaghetti and marshmallow tower building competition to 110 freshman students (34 teams) and the top five teams received awards (February 2012).
6. Twelve students participated in the Math, Engineering and Science Conference (MESCON) during March 23-24, 2012 at the University of Evansville and present their design projects (paper/poster presentations). Mercer student teams received two “Best

Paper Awards and Cash Awards” one for their Poster and another for their Podium presentations.

7. Second Mercer Innovation Chase Competition was held during April 12-14, 2012. The winning team was sent to the Chicago Innovation Chase competition held during September 6-10, 2012.
8. Promoted and organized red paper clip challenge for value creation to 160 freshman students (40 teams) and the top three teams received awards (February 2013).
9. Sixteen Mercer students will be participating and presenting their design project results in MESCON to be held at University of Evansville during March 22-23, 2013.

Entrepreneurial Design Projects

MCIE has funded several entrepreneurial design projects in the areas of Biomedical, Computer, Electrical, Environmental, Industrial/Manufacturing, and Mechanical Engineering. Only selected creative student design project(s)/course module(s) in manufacturing involving CAD/CAM, Rapid Prototyping and Robotics are briefly presented and discussed below:

Retrofitting of Tabletop CNC Lathe¹⁷ (Senior Design Project):

This project describes the infusion of new technology and the resulting extended useful life of a 20 year old computer numerical controlled (CNC) tabletop lathe. Key to the success of the project was the ability to have a low cost, high performance real-time controller that was compatible with the existing electrical components of the lathe. The Enhanced Machine Controller (EMC) Project software installed on a personal computer running a Linux Operating System was the basis of the new controller design. Artifacts were created using G-codes from existing models. The retrofitted lathe is currently being used in the Intelligent Manufacturing Systems Lab at Mercer University for teaching computer aided manufacturing and providing hands-on experience to students taking manufacturing courses (Figure 2).

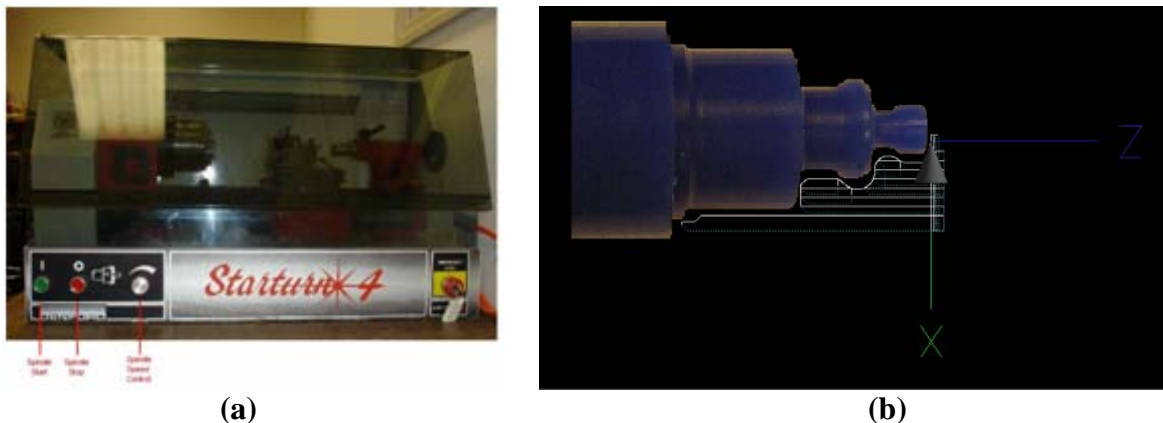

Figure 2. Tabletop CNC lathe: (a) Retrofitted and functional; (b) Artifact made^[22]

Affordable Prototyping with the MakerBot Cupcake (Senior Design Project)¹⁸:

The MakerBot Cupcake CNC machine that uses additive manufacturing technology to create objects made of Acrylonitrile Butadiene Styrene (ABS) was assembled and made operational. It

converts a 3D model to a usable physical object. Alterations such as reducing idler wheel thickness, using a higher grade material for the insulation between the heater barrel and the rest of the extruder, and fabricating a removable heat source were made to the machine to ease maintenance and improve reliability.

The MakerBot consists of a wooden frame, a build platform with X and Y pulleys for movement, and a Z platform on which the extruder sits. The extruder, and the X, Y, and Z stepper motors all have a circuit board which is connected to the Cupcake's motherboard (Figure 3). Cupcake uses additive technology to form 3-D parts, which is ideal for prototyping and manufacturing a small number of parts. Additive technology allows the capability to print interior structures.

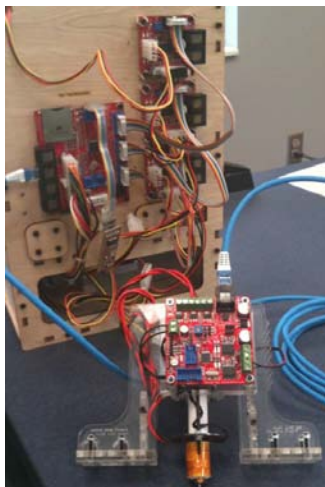

(a)

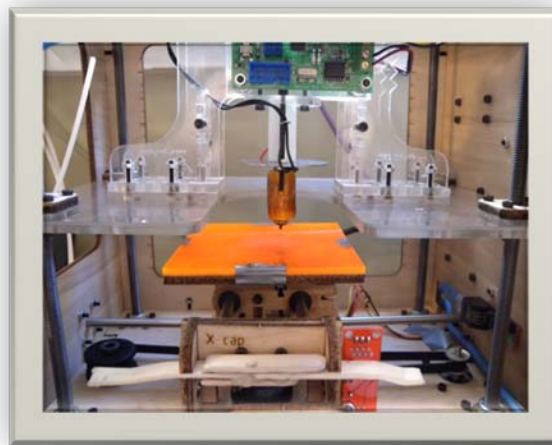

(b)

Figure 3. MakerBot - (a) circuit board details and (b) assembly

The following steps were taken to achieve successful operation of MakerBot:

- Downloading software
- Testing motors independently for vibration and backlash
- Testing extruder for idler wheel and heater barrel
- Printing: misprints or successful prints

Using the MakerBot, a whistle was successfully printed as shown in Figure 4. The interior ball did not come free from the bottom wall, and it is possible that this is a complication of the nozzle being too close to the Z platform at the start of the build, or an error in the G-codes. The whistle is a good example to print because of its interior features. The whistle is hollow with an interior ball, which cannot be achieved using a traditional milling machine.

Single and double gears were printed that have a hollow honeycomb interior, which reduces use of unnecessary ABS filament. This can be seen in the interior of the gear. Both the single and double gears were printed and different views of the gears are shown in Figure 5.

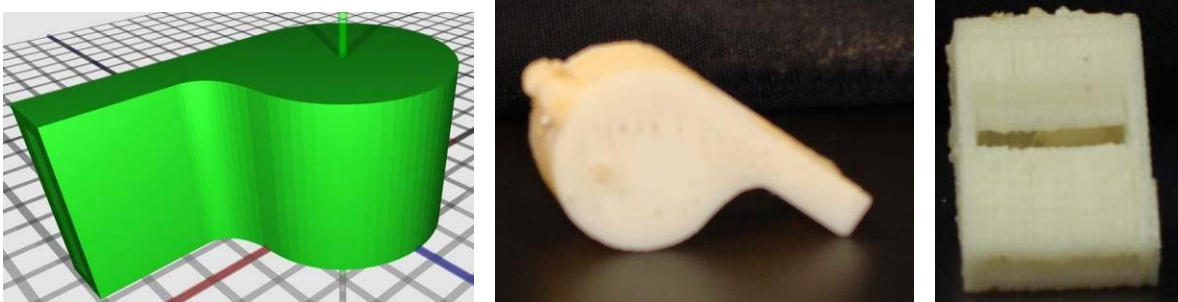
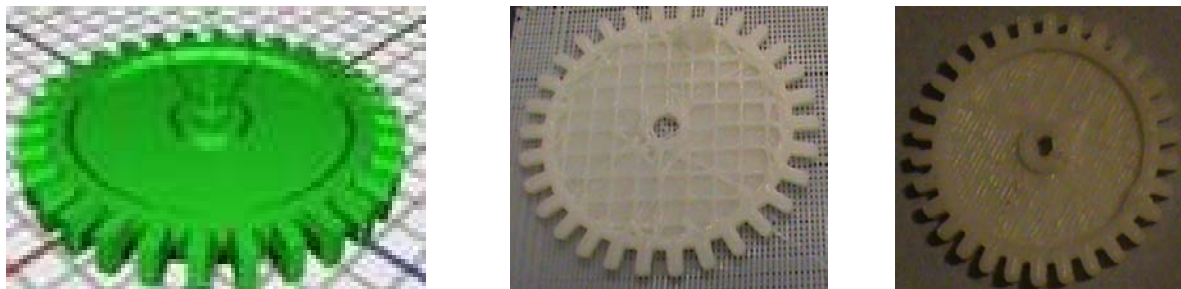
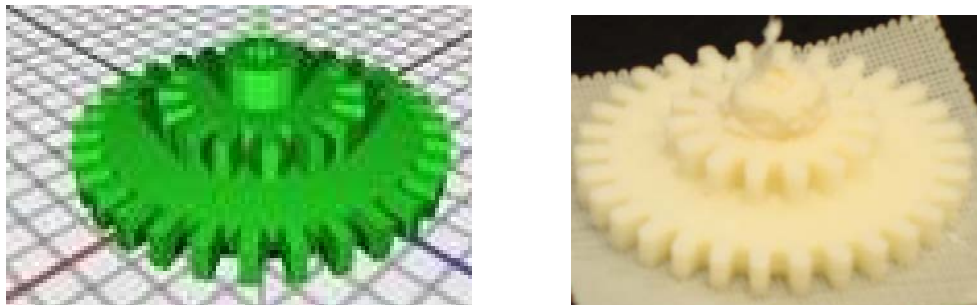

Figure 4. Printed part - different views of the whistle



(a)



(b)

Figure 5. Different views of (a) single gear and (b) double gear

The 3D printer is currently being used in the Center for Innovation and Entrepreneurship for teaching the concept of additive manufacturing and rapid prototyping to undergraduate students in engineering. The printer has already been used by a number of student teams working on their senior design/research projects to print their parts and prototypes.

Autonomous Robot Competition (ISE 429 Robotics: Course Module)¹⁹:

The POP BOT¹⁹, a complete robot kit, was chosen as the robot platform for the competition. The kit comes with everything needed to construct an autonomous robot. This includes motors, wheels, chassis material, LCD display, and several sensors. The sensors included in the kit were two touch sensors, two infrared reflector boards, and an infrared range finder. In addition, the kit includes a piezo speaker, 2 line LCD display, servo motor with head mount, two DC motors, main board with USB interface, USB connector cable, program disk, wiring, wheels, platform, construction parts, 4 batteries, and a companion manual. The robot is propelled by two 5 volt

motors. The robot comes with multiple sensors for different applications of the robot. The sensors chosen for the competition were the infrared sensors. The kit has one infrared sensor which was complimented by additional sensors to provide detection in multiple directions. The robot used controlled movements to avoid obstacles and continue forward progress. The robot was coded to make simple direction changes using the motors to move and avoid obstacles.

Student teams constructed autonomous robots to compete in two different contests. The first contest places the robots in an arena and challenges them to avoid obstacles and other robots. The robot must operate without human control and for a specified length of time. Points are deducted for contact with objects and other robots. The second test places the robot in a hallway and challenges the robot to traverse the hallway from one end to the other while avoiding obstacles placed in its path. The robot must also operate without human control for the length of the challenge. Points are deducted for not completing the path. Points are also deducted for the robot turning completely around while traversing the path or coming into contact with objects displayed in its path or the walls.

To complete these challenges, the robot must be outfitted with sensors to detect obstacles. These sensors are triggered by external stimuli and converted to signals sent to the arduino¹⁹. The signals from the sensors are interpreted and used to program the behavior of the robot. One of the POP BOT built and tested by a student team for the competition is shown in Figure 6.



Figure 6. Autonomous POP BOT built and tested

Upon completion of the robot build, it was tested with regards to the competitions it would be participating in. The robot demonstrated capable performance in the obstacle avoidance. The infrared sensors were able to detect objects up to 32 centimeters away. Small changes in motor speed and direction proved to be effective in directing the robot to avoid obstacles when detected. The robot performed well in the course traversal but could be improved by introducing course correction in the coding. Another improvement would be the use of fuzzy logic to control the speed of the motors.

Student teams of all the projects discussed in this section participated in the annual design project competitions held at MUSE. These projects results were presented in the ASEE, KEEN, NCIIA, IEMS, and ICMES conferences and published in the conference proceedings.

Program Assessment

The KEEN program seeks to produce EMEs. Principles of KEEN emphasize Technical Knowledge and Skills, Business Acumen, Customer Awareness and Societal Values and the KEEN Student Outcomes (KSOs). A KEEN student should be able to:

1. Effectively collaborate in a team setting
2. Apply critical and creative thinking to ambiguous problems
3. Construct and effectively communicate a customer-appropriate value proposition
4. Persist through, and learn from failure (to understand what is needed to succeed)
5. Effectively manage projects through to commercialization or final product delivery
6. Demonstrate voluntary social responsibility
7. Relate personal liberties and free enterprise to entrepreneurship

The KEEN–TTI assessment tools were used in assessing freshmen through seniors by administering the KEEN–TTI performance DNA²⁰⁻²¹. The professional competencies (or people skills) analyzed through the TTI survey originate from a DNA inventory of skills frequent in engineering and measure what personal skills the individual has already mastered well versus what skills need mastering and could prove to be useful in either academic or professional engineering environments. Typically the average job requires between three to five professional skills and the average person has mastered a similar number of professional skills from the DNA inventory²². The 23 professional skills measured by TTI’s survey tool are listed in Table 2. Some of the skills listed such as leadership, teamwork, conflict management, creativity/innovation, goal orientation, negotiation, decision making, etc. are discussed in entrepreneurial courses and course modules through case studies and term projects at MUSE.

Table 2. TTI’s DNA inventory professional skills

Leadership	Diplomacy
Employee Development/Coaching	Personal Effectiveness
Teamwork	Presenting
Conflict Management	Management
Interpersonal Skills	Negotiation
Analytical Problem Solving	Persuasion
Creativity/Innovation	Empathy
Written Communication	Continuous Learning
Customer Service	Futuristic Thinking
Flexibility	Decision Making
Goal Orientation	Self-Management (time and priorities)
Planning/Organizing	

In addition to the 23 professional competencies outlined above, TTI has also designated several subgroups ideal for various scenarios in the engineering academic environment at any institution; a few consistent with engineering students analyzed are outlined in Table 3.

A data set consisting of 104 engineering students comprising of two separate subgroups: gender and class status were used to conduct the study. Table 4 provides a numerical breakdown of each subgroup based on the original population. The ANOVA tables generated in Minitab²³ for all 23 professional competencies were analyzed to determine any existing differences in the means of the two genders and the four class levels and the P-values are given in Table 5.

Table 3. Professional competencies for students²²

TTI Description	Effectively collaborate in a team setting	Applying critical and creative thinking to ambiguous problems	Persist through and learn from failure
Equivalent for Mercer Students Analyzed	Group projects/assignments (PDR, CDR)	Design phase of senior design, R&D projects	Student's overall undergraduate success
Professional Competencies	Teamwork Interpersonal Skills Negotiation Presenting Persuasion Written Communication	Creativity/Innovation Continuous Learning Flexibility Decision Making Persuasion Presenting Problem-Solving Self-Management	Personal Effectiveness Goal Orientation Continuous Learning Leadership Decision Making Flexibility

PDR: Preliminary Design Review; CDR: Critical Design Review

Table 4. Count and percentage by subgroup – gender and class status

Gender	Count	Percent	Female			Male		
			Class	Count	Percent	Class	Count	Percent
Female	28	26.9231	Freshmen	9	32.1429	Freshmen	35	46.0526
Male	76	73.0769	Sophomore	2	7.1429	Sophomore	6	7.8947
			Junior	7	25.0000	Junior	9	11.8421
			Senior	10	35.7143	Senior	26	34.2105

Table 5. Minitab ANOVA test P-values for 23 people skills

People Skills	Gender	Class	People Skills	Gender	Class
Leadership	0.597	0.915	Diplomacy	0.742	0.175
Employee Development	0.101	0.268	Personal Effectiveness	0.349	0.061
Teamwork	0.373	0.312	Presenting	0.756	0.901
Conflict Management	0.594	0.413	Management	0.076	0.908
Interpersonal Skills	0.442	0.391	Negotiation	0.778	0.251
Analytical Problem-Solving	0.819	0.003	Persuasion	0.794	0.913
Creativity/Innovation	0.820	0.241	Empathy	0.136	0.055
Written Communication	0.169	0.964	Continuous Learning	0.749	0.408
Customer Service	0.773	0.015	Futuristic Thinking	0.068	0.761
Flexibility	0.740	0.484	Decision Making	0.144	0.249
Goal Orientation	0.694	0.646	Self-Management	0.716	0.226
Planning/Organizing	0.857	0.015			

*significant P-values are highlighted

According to the ANOVA tests, three of the people skills analyzed have significant differences between their means all by the class status subgroup. These include: Analytical Problem-Solving, Customer Service, and Planning/Organizing as their P-values $< \alpha = 0.05$.

A further analysis of the mean values for each professional competency can be visualized in the spider charts generated in Excel²⁴ (Figures 7 and 8) by gender and class status respectively to better illustrate the significant differences between the values of interest. Table 6 lists the percent changes and differences by gender and class status for the spider plots. Additionally, Table 7 displays the ranking of each people skill by gender.

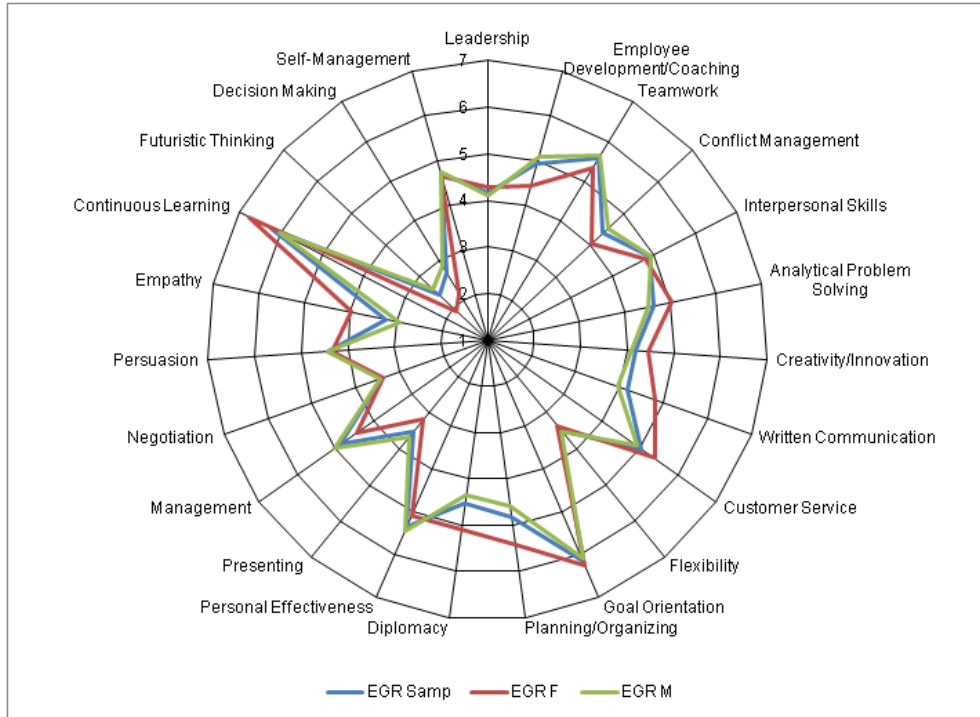

Figure 7. Spider chart for 23 people skills by gender

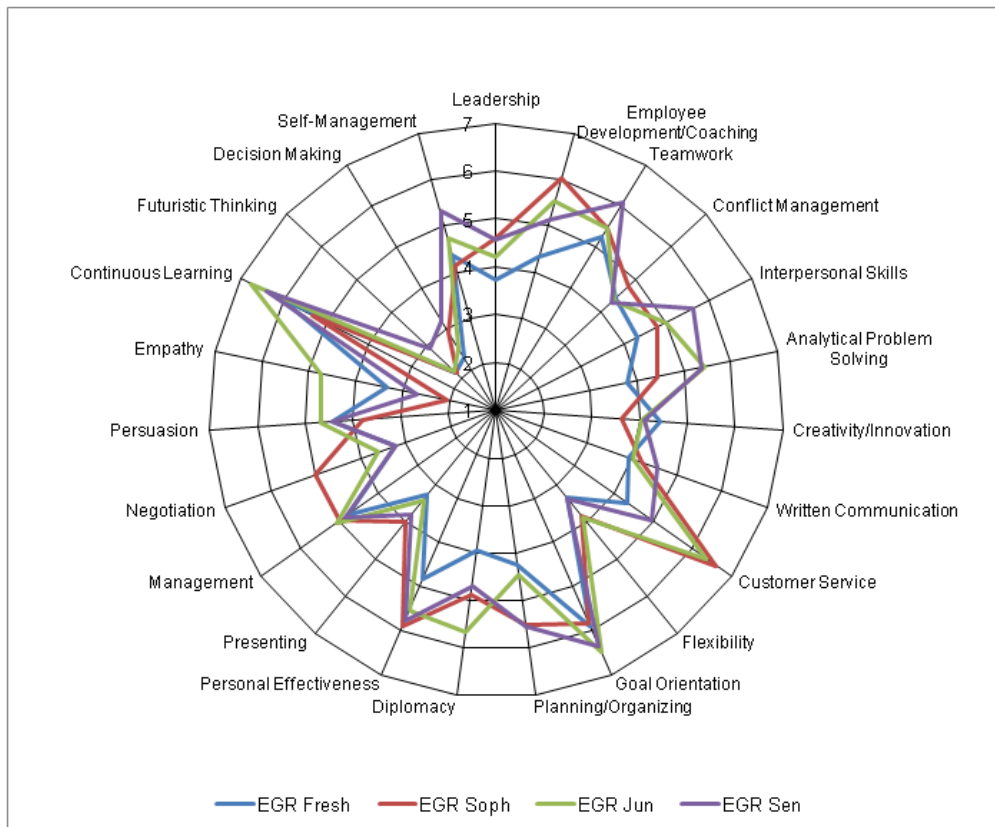

Figure 8. Spider chart for 23 people skills by class status

Table 6. % difference between gender & % change between class status - 23 people skills

People Skill	% Difference (Male to Female)	% Change (Freshman to Seniors)	People Skill	% Difference (Male to Female)	% Change (Freshman to Seniors)
Leadership	4.41%	22.24%	Diplomacy	16.18%	18.71%
Employee Development	13.69%	19.00%	Personal Effectiveness	6.70%	19.00%
Teamwork	5.95%	16.00%	Presenting	14.46%	16.62%
Conflict Management	11.00%	-3.28%	Management	11.79%	1.99%
Interpersonal Skills	3.06%	29.92%	Negotiation	1.53%	0.09%
Analytical Pro. Solving	10.99%	41.27%	Persuasion	2.18%	-0.11%
Creativity/Innovation	8.35%	-7.16%	Empathy	30.55%	-19.48%
Written Communication	19.12%	16.47%	Continuous Learning	11.31%	5.90%
Customer Service	9.21%	14.16%	Futuristic Thinking	31.41%	35.15%
Flexibility	4.26%	0.87%	Decision Making	27.40%	38.46%
Goal Orientation	2.30%	7.77%	Self-Management	1.49%	22.08%
Planning/Organizing	16.60%	31.08%			

*RED \geq 5.0% difference between M and F; GREEN \leq 0.0% change between freshman and seniors

Table 7. Ranking of people skills by gender

Rank	Female	Rank	Male
1	Continuous Learning	1	Goal Orientation
2	Goal Orientation	2	Continuous Learning
3	Planning/Organizing	3	Teamwork
4	Customer Service	4	Personal Effectiveness
5	Teamwork	5	Employee Development/Coaching
6	Diplomacy	6	Management
7	Personal Effectiveness	7	Interpersonal Skills
8	Analytical Problem Solving	8	Customer Service
9	Interpersonal Skills	9	Self-Management
10	Written Communication	10	Planning/Organizing
11	Self-Management	11	Conflict Management
12	Creativity/Innovation	12	Analytical Problem Solving
13	Management	13	Persuasion
14	Employee Development/Coaching	14	Diplomacy
15	Persuasion	15	Leadership
16	Leadership	16	Creativity/Innovation
17	Conflict Management	17	Written Communication
18	Empathy	18	Presenting
19	Negotiation	19	Flexibility
20	Flexibility	20	Negotiation
21	Presenting	21	Empathy
22	Decision Making	22	Decision Making
23	Futuristic Thinking	23	Futuristic Thinking

According to the spider charts and percent differences and percent changes for the people skills by gender and class status, the student groups studied tend to improve and/or master all of the people skills by the time they are seniors with the exception of Conflict Management, Creativity/Innovation, Persuasion, and Empathy, which all decrease at the senior level. In terms of comparing people skills by gender, both males and females seem to share the following people skills (\leq 5.0% difference): Leadership, Interpersonal Skills, Flexibility, Goal Orientation, Negotiation, Persuasion, and Self-Management. All other people skills are significantly different by gender.

In addition, Table 7 helps to better visualize what people skills the students has mastered and need to learn or master by gender. Generally speaking, both genders need improvement on their Futuristic Thinking, while both have mastered Continuous Learning, Goal Orientation, and Teamwork. Also it is apparent that male students need more assistance when it comes to Written Communication, Diplomacy, and Empathy; while females need to focus on improving their Management, Conflict Management, and Employee Development/Coaching in comparison to males. Three separate regression analyses²⁵ were performed in Table 8 that directly correspond to the groups of Professional Competencies presented in Table 3.

Table 8. Regression analysis: teamwork, creativity/innovation, and personal effectiveness

TEAMWORK	The regression equation is
	Teamwork = 3.66 + 0.263 Interpersonal Skills + 0.0201 Written Communication + 0.0954 Presenting + 0.0120 Negotiation + 0.0350 Persuasion
	Predictor Coef SE Coef T P S or NS
	Constant 3.6649 0.4312 8.50 0.000 S
	Interpersonal Skills 0.26258 0.07047 3.73 0.000 S
	Written Communication 0.02014 0.07509 0.27 0.789 NS
	Presenting 0.09539 0.08091 1.18 0.241 NS
CREATIVITY/INNOVATION	The regression equation is
	Creativity/Innovation = 1.03 - 0.144 Analytical Problem Solving + 0.163 Flexibility + 0.0372 Presenting + 0.433 Persuasion + 0.340 Continuous Learning + 0.103 Decision Making - 0.247 Self-Management (time and prior
	Predictor Coef SE Coef T P S or NS
	Constant 1.0258 0.7143 1.44 0.154 NS
	Analytical Problem Solving -0.1442 0.1404 -1.03 0.307 NS
	Flexibility 0.1632 0.1142 1.43 0.156 NS
	Presenting 0.03720 0.08882 0.42 0.676 NS
PERSONAL EFFECTIVENESS	The regression equation is
	Personal Effectiveness = 2.59 + 0.180 Leadership - 0.0538 Flexibility + 0.380 Goal Orientation - 0.0659 Continuous Learning + 0.101 Decision Making
	Predictor Coef SE Coef T P S or NS
	Constant 2.5880 0.4801 5.39 0.000 S
	Leadership 0.18016 0.06473 2.78 0.006 S
	Flexibility -0.05383 0.07672 -0.70 0.485 NS
	Goal Orientation 0.38004 0.08243 4.61 0.000 S
Continuous Learning -0.06590 0.06857 -0.96 0.339 NS	
Decision Making 0.10138 0.07772 1.30 0.195 NS	

The first regression performed in Minitab was used to determine which of the five paired people skills were actually significant to the Teamwork trait/skill. From the analysis it is seen that only the intercept and Interpersonal Skills are significant to the regression for Teamwork. This suggests that the students are most concerned with their interactions with other students while working in groups. In terms of Creativity/Innovation, the skills of Persuasion, Continuous Learning, and Self-Management were most significant to the regression. The third and the final regression for Personal Effectiveness demonstrate that the students are most successful and effective when Leadership and Goal Orientation skills are mastered.

Results and Conclusions

The entrepreneurship certificate program established in 2007 is expanding and achieved a number of mile stones: Engineering, Business, Medical, Liberal Arts, and Law faculty members are actively engaged in promoting entrepreneurship program across the Mercer campus through the Mercer Center for Innovation and Entrepreneurship; both graduate and undergraduate students are attracted to the entrepreneurship related courses; a number of entrepreneurial senior design projects were funded and the student teams participated in the “Business Plan Competitions” as well as presented their design projects in regional, national, and international conferences. Some of the design projects received regional and national recognitions/awards during the period 2007-2012.

The entrepreneurship courses and modules developed and implemented help to instill entrepreneurial mindset among engineering students and graduates. Extracurricular activities such as business plan competitions, Mercer innovation chase competitions, participation in conferences, and invited speakers/seminars promote innovation and creativity among students.

The study on the 23 People Skills demonstrated that most of the students improve in 19 of the 23 areas by the time they are seniors, but lose mastery of skills in Conflict Management, Creativity/Innovation, Persuasion, and Empathy. This finding proves that there exists a recognizable need for the implementation of a program(s) to help enhance the People Skills of the students. Additionally, it can be concluded that the profile of incoming freshmen consists of more males than females with poor problem-solving skills.

Sustainability

Other faculty members across the Mercer Campus are being encouraged to participate in the entrepreneurship program. Currently, faculty from engineering, business, medical, liberal arts, and law schools as well as more than 100 active engineering and non-engineering students are participating, promoting and enhancing entrepreneurship activities across the Mercer campus.

Mercer’s entrepreneurship faculty team is actively seeking funds from government funding agencies, private foundations, local industries and Mercer alumni. So far the team has received funding from NCIIA in addition to Kern Family Foundation grants. Kern Family Foundation has approved additional funding required until 2012 in order to expand the entrepreneurship program across the Mercer campus. In addition, through AIM funds, the Mercer Center for Innovation and Entrepreneurship has been developed.

Mercer's entrepreneurship program is actively developing network of outside financial support from: Mercer alumni, local industries, successful entrepreneurs, state and local governments, Angel Investors Group etc. Some of Mercer's alumni have already come forward to actively participate and contribute financially to senior design projects. Participating faculty members are planning to seek additional funding for the program by submitting proposals to other extra mural funding agencies.

Future Work

The MCIE and MEEEP will concentrate on educational as well as scholarly activities. The educational opportunities will be focused on developing and offering a minor in entrepreneurship across the Mercer campus covering all aspects of invention, innovation, creativity, and entrepreneurship. The courses will focus on project/case-based teaching and learning. The scholarly activities will initially focus on the development of low-cost rapid prototyping and smart product design facilities. There will be opportunities for innovative interdisciplinary initiatives by the faculty and students from all participating schools and colleges. Findings from the research conducted at the center will be presented at national and international conferences and published in journals and conference proceedings.

The MCIE will (1) provide stipend for engaging undergraduate and graduate students in interdisciplinary research; (2) train the faculty and students in the development of an entrepreneurial mindset through workshops and seminars; (3) provide funds for participation in KEEN and NCIIA conferences; and (4) purchase machines and equipment for research in manufacturing, biomedical, and energy systems.

The products that will be produced from the MCIE activities include but are not limited to: development of low-cost facilities and devices for rapid prototyping, production of alternate energy, and smart product design; presentation of research results in regional/national/international conferences; publications in journals and conference proceedings; students taking entrepreneurship minor/elective courses; curricula, instructional materials, tools and techniques, patents, protocols, resource manuals, project reports, training sessions/workshops, and conferences; increase in undergraduate/graduate student enrollment; collaboration between KEEN schools, and development of national and international collaborative studies/projects through networking.

Acknowledgments

The author wishes to express his sincere thanks to Kern Family Foundation for the initial grant during 2007-09 and the expansion grant during 2009-11 to promote invention, innovation, and entrepreneurship in engineering education at MUSE.

References

- [1] Shane S., and Venkataraman, S. (2000). The Promise of Entrepreneurship as a Field of Research. *Academy of Management Review*, Vol. 25, No. 1, pp. 217-226.
- [2] Kuratko, D. (1995). Entrepreneurship in International Encyclopedia of Business and Management. International Thomson Press, London.
- [3] Hisrich R. D., Peters, M. P., and Shepherd, D. A. (2008). Entrepreneurship. McGraw-Hill, 7th Edition, New York.
- [4] Blenker, P., Dreisler, P., Faergemann, H. M., and Kjeldsen, J. (2008). A Framework for Developing Entrepreneurship Education in a University Context. *Int. J. Entrepreneurship and Small Business*, Vol. 5, No. 1, pp. 45-63.
- [5] Anderson, D. M. (2008). Design for Manufacturability and Concurrent Engineering. CIM Press, California.
- [6] Boothroyd, G., Dewhurst, P., and Knight, W. (2002). Product Design for Manufacture and Assembly. Taylor and Francis Group, Second Edition, New York.
- [7] Dorf, R. C., and Byers, T. H. (2008). Technology Ventures: From Idea to Enterprise. McGraw-Hill, 2nd Edition, New York.
- [8] Gaspar F. C. (2009). The Stimulation of Entrepreneurship through Venture Capital and Business Incubation. *Int. J. Entrepreneurship and Innovation Management*, Vol. 9, No. 4, pp. 396-415.
- [9] Messica A., and Agmon, T. (2009). Venture Capital Dynamics, the Public Sector and the High Technology Industry. *Int. J. Entrepreneurship and Innovation Management*, Vol. 10, No. 3/4, pp. 227-242.
- [10] Timmons, J. A., and Spinelli, S. (2009). New Venture Creation: Entrepreneurship for the 21st Century. McGraw-Hill, 8th Edition, New York.
- [11] Sanz-Velasco S. A., and Saemundsson, R. (2008). Entrepreneurial Learning in Academic Spin-offs: A Business Model Perspective. *Int. J. Entrepreneurship and Innovation Management*, Vol. 8, No. 1, pp. 15-35.
- [12] McMullen W. E., and Long, W. A. (1987). Entrepreneurship Education in the Nineties. *Journal of Business Venturing*, 2: 261-275.
- [13] Solomon, G. T., Duffy, S., and Tarabishy, A. (2002). The State of Entrepreneurship Education in the United States. A Nationwide Survey and Analysis. *International Journal of Entrepreneurship Education*, 1(1): pp. 65-86.
- [14] Kriewall, T. J., and Mekemson, K. (2010). Instilling the Entrepreneurial Mindset into Engineering Undergraduates, *The Journal of Engineering Entrepreneurship*, Vol. 1, No. 1, pp. 5-19.
- [15] Radharamanan, R., and Juang, J. N. (2012). Innovation and Entrepreneurship in Engineering Education at MUSE. *Journal of the Chinese Institute of Engineers*, Vol. 35, No. 1, pp. 25-36.
- [16] Mercer University Catalog. (2012). Macon Campus, Academic Year 2012-2013.
- [17] Amato, D., Laree, A., Abroad, R., and Duan, T. (2007), CNC Lathe Project, Critical Design Review, School of Engineering, Mercer University, Macon, GA, USA.
- [18] Dawson, S. N., Coonce, A. M., and Cox, L. J. (2010), Recycling System for the Cupcake 3D Printer. *Critical Design Review*, School of Engineering, Mercer University.
- [19] "The Arduino Compatible POP-BOT Mobile Robot Kit. (2012). Activity Manual Version 1.0 Standard, Innovative Experiment Co. Ltd., April 16, 2012.
- [20] <http://www.ttikeen.com/>. Retrieved on 1/12/12.
- [21] Petersen, O., Jordan, B., and Radharamanan, R. (2011). A Logistic Framework for the KEEN Initiative, *Annual Fall KEEN Conference*, September 30 - October 1, 2011
- [22] Bonnstetter, R. J. and Vlasin, R. (2011). *Study Habit Recommendations* [PDF Document]. Retrieved July 21, 2012, from <http://ttikeen.com/files/study-habit-recommendations-2011.pdf>
- [23] Minitab 16 Statistical Software (2010). [Computer Software], State College, PA: Minitab, Inc. Retrieved from <http://www.minitab.com>
- [24] Microsoft Excel (2010). Microsoft Office Professional Plus. [Computer Software], Santa Rosa, CA: Microsoft Corporation.
- [25] Hines, W. H. et al. (2003). Probability and Statistics in Engineering. (Fourth Edition). Hoboken, NJ: John Wiley & Sons, Inc.

Can Students Build Production-Quality Software?

Gene Fisher
California Polytechnic State University
San Luis Obispo, CA 93407

Abstract

The question posed in the title of this paper has been asked in many forms. There have been thoughtful scholarly publications on the subject, and less than scholarly opinion pieces. This paper asks the question in the context of a year-long capstone course in software engineering, taught at Cal Poly University San Luis Obispo. Specifically, if product development is the overriding goal for such a course, can a team of senior-level software engineering students deliver and deploy a genuinely production-quality software product?

Unfortunately, the answer to this question in our case was "No". There are a number of reasons for the negative result, which will be examined in the paper. The examination will include consideration of whether it is reasonable to have product development as the primary focus of a university course, or if doing so sacrifices other important pedagogical goals.

1. Introduction

We have offered a year-long capstone course in software engineering since the 2000-01 academic year. The course was introduced at the same time as our degree major in software engineering, which we currently offer in addition to degrees in Computer Science and Computer Engineering.

Our capstone has been the subject of a number of previous reports, which have chronicled our progress^{6,7,8,9}. Over its years of being offered, we have focused to varying degrees on a number of educational objectives. From the perspective of the students in the course, the objectives include:

1. apply the skills learned in introductory software engineering courses to a real-world software project
2. work with an external customer, on a project of specific interest to that customer
3. work in project teams of varying sizes, including in teams comprised of upper-class and lower-class students of software engineering
4. learn skills of project management
5. enhance technical skills of software development
6. deploy a working product of some form

The first objective is very common to engineering capstone classes across the disciplines. That is, students take what they have learned in lower-level courses and apply it in a setting beyond the classroom.

Our second objective is also a common feature of capstone courses, where students work with external customers. "External" means that the customers are beyond course instructors acting in the *role* of customers. For us, customers are often chosen from outside industrial partners⁷. In some cases, we have chosen partners from on our own campus⁸, but still beyond the our own department.

The third objective for our capstone course, that of teamwork, is also nearly universal in a capstone experience. A somewhat unusual variant of our team structure has been to mix students from our introductory courses and capstone course in the same teams. This provides the upper-level capstone students the opportunity to manage the work of the lower-level students. This team structure was a feature of the initial offering of our capstone course⁶. It has not been repeated in many subsequent offerings, due primarily to class logistical difficulties.

The fourth objective of project management is again very common in a capstone class. In the cases where we have combined upper- and lower-division students, the capstone students managed their lower-division team members. In other cases, students would choose to focus on management primarily, or all students would assume rotating management duties.

The fifth objective of enhancing technical skills is important, but for us, as well as for others reporting in the literature, a secondary objective. In order to achieve the other course objectives, technical skills will invariably be improved. However, teaching strictly technical content is taken to be the objective of lower-level courses that precede the capstone.

Finally, the sixth objective, that of building a real software product, has always been an important part of our capstone. However, as with the fifth objective, the product itself has not typically been the primary focus of the course.

In our experience, fully achieving all six of the objectives has not been possible in any given year. We have therefore chosen to emphasize different objectives, depending on the instructional staff and the nature of the customers involved.

For the 2011-12 academic year, the focus was squarely on the product. In previous years, we had sometimes wondered if it would be advantageous to focus primarily on product delivery, to offer students a more real-world learning environment. The experience we gained in this effort, while not successful in its primary objective, will indeed help us continue to refine the course. It will also help us understand how to balance the different objectives to be achieved in a capstone.

2. Curriculum Structure of the Capstone Course

As noted in the introduction, ours is a year-long capstone experience. The curriculum is divided into the following three courses, each lasting for a ten-week quarter of instruction:

1. ***Requirements Engineering***
2. ***Software Construction***
3. ***Software Deployment***

These titles reflect a somewhat traditional sequence of software development, but in fact provide only general guidelines for the structure of the curriculum. Depending on faculty preferences in any given year, an agile development process may be used, where students iteratively analyze requirements, construct the software, and deploy it.

While software testing is not specifically listed in the course titles, it of course plays a key role. The faculty who teach the capstone have used methodologies ranging from test-first to test-last to points in between. In 2009, students conducted a controlled experiment to compare the effectiveness of different testing approaches⁹.

3. Specific Structure of 2011-2012 Capstone Course

The course involved a project to build a course scheduling tool for our own campus. The need for such a tool had been well established, and a number of efforts had been undertaken in the past to produce one. Key features envisioned for the tool were the following:

- an easy-to-use database of instructor information, which includes course teaching preferences and teaching time preferences
- an easy-to-use database of a department's course offerings, including courses planned for particular quarters
- the ability to define department-specific scheduling constraints to guide the scheduling process
- a sophisticated scheduling algorithm that generates an optimized schedule, based on instructor preferences, planned course offerings, and departmental constraints
- the ability to fine tune a generated schedule, with automated checking to ensure schedule completeness and consistency

The tool is intended to be used at the department level, by the same people who normally perform department scheduling. The result of a scheduling session is in a form suitable for electronic submission to the campus scheduling database.

Achieving the features listed above is in fact an ambitious undertaking. An advantage we had in our efforts is a history of working on course scheduling projects. Specifically, versions of the scheduling tool had been assigned as two-quarter class projects in undergraduate software engineering courses for a number of years. In addition, there had been several senior projects that had refined key scheduling functionality, including the scheduling algorithm and schedule database management. The results of these past efforts provided a solid base on which to work. Using previous student work as a basis, we believed that a production-quality scheduling tool was an achievable goal.

What was significantly new about the project was to expand the focus from a small-scale department effort to a campus-wide effort. In late Spring 2011, a mailing was sent to department schedulers across campus. The mailing briefly explained the objectives of the scheduler project, and inquired about interest in project participation. Of the approximately 70 recipients of the mailing, nearly half responded with an interest in participating in the initial requirements gathering phase. A follow-on message was sent in the week before classes begin, to confirm continued

interest in project participation. A total of 36 respondents responded affirmatively.

4. Related Work and the Definition of "Production-Quality"

The goal of building production-quality student software has been subject of a number of recent reports^{1,2,3,4,5,10}. The curricula described in these works share most of the goals outlined above for our courses. Also common to these efforts and ours are the challenges faced when students endeavor to build production software. These challenges include:

1. finding suitable outside partners, from commercial or non-commercial organizations
2. logistical difficulties in collaborating with outside partners
3. clarifying deliverable expectations with the partners, including post-delivery work

The last of these points requires a clear definition of "production-quality" software, so that all concerned can be clear on the deliverables. Allen et al.¹ define the term "production programming" as "creating or modifying a software product to meet the needs of real customers". Others use a comparable definition.

While the Allen definition is useful, it does not refer specifically to the post-delivery needs of customers. In some cases it may be possible to deliver a stable and well-tested product to customers, with limited post-delivery support. However in today's world of fast-changing software products, having a maintenance and evolution plan is an increasingly important part of a "production-quality" deliverable.

Post-delivery support can definitely be problematic for student projects. For example, Lange et al.³ note that some of their customers have expected on-going "tech support" after student work on the project is completed. They indicate that such support must be clearly addressed in the initial project agreement, presumably indicating that it will not be available.

In several of the works cited above, there is discussion of different means to provide continuing product support. Such means include projects that continue across multiple years or making student products available to the open-source community. In any case, we believe that providing post-delivery support is a key part of truly "production-quality" software.

In our case, we did not adequately plan for post-delivery support, which is an important reason we consider our efforts not to have been successful. This topic is discussed further in the next section of the paper.

5. Results and Conclusions

As noted in the paper abstract, we did not achieve our primary objective of building a truly production-quality product. The specific reasons for our lack of success are the following:

1. The scope the project was overly ambitious, even given the substantial preparatory work that had come before.
2. The project became a fully ground-up effort, rather than being an upgrade or incremental addition to an existing system.

3. A specific technical decision to build a web-based application instead of a desktop application led to a number of delays in the project.
4. We were unable to secure a long-term maintenance agreement with any official organization on campus.
5. Students will be, and *need to be*, students.

The first reason for failure is of course extremely common in any engineering activity. For a group of students who cannot devote full time to a project, estimating project scope is a significant challenge. With a particularly well-organized and motivated team of students, producing a substantial amount of work may be possible. However in many if not most cases, the nature of academic work means that the scope of projects must be kept smaller than that envisioned for many useful software products. The lesson (re-)learned here is to be ever-mindful of defining student projects to have a suitably limited scope.

We had hoped to avoid the second reason for failure by using an existing base of operational code. However, we gave the students substantial latitude in choosing the project direction. Despite strong faculty recommendations to the contrary, it was the students' choice to re-develop from the ground up rather than using the existing code base. This aspect of failure reinforces the lesson from above. Namely that faculty need to be careful to control the scope of the project, and mindfully assert managerial control when necessary. This lesson is further reinforced by reports in the literature, including most of those cited in Section 4. Many of the successful efforts to build production quality products involve students adding incrementally to an existing project rather than building completely ground-up projects.

The third reason for failure is also common to software projects, that is, choosing the wrong technology. Understanding the development technology has long been recognized as a key factor in the success of a software project. While the students involved in our project had significant experience in developing desktop applications, only a few had web-based development experience. The steepness of the learning curve was far greater than anticipated. The lesson here is again one of asserting a reasonable amount of managerial control of the project. It may be OK to have a "sink or swim" policy for a student-run capstone project, and such a policy can provide a good learning experience for the students. However the "sink or swim" policy may well conflict with the goal to build production-quality software, which in our case it did.

The fourth reason for failure relates to the definition of "production-quality" software discussed in the preceding section of the paper. Even if the product had been suitable for deployment to the customers, it would have required some form of on-going development. We had hoped to make an agreement with a suitable campus organization to take over the project, but this agreement did not come to fruition. Understanding the importance of post-delivery development is one of the most important lessons we learned from this capstone project.

Last and not least, students must be allowed to be students. They are not full-time workers who bring pre-existing skills to the workplace. They must be given the opportunity to fail and learn from that failure. In this context, having students build production-quality software is always a challenge, and may not always be a realistic goal.

Bibliography

- [1] E. Allen, R. Cartwright, C. Reis, "Production Programming in the Classroom", Proceedings of the ACM SIGCSE Conference, Reno, Nevada, February 2003.
- [2] S. Gorka, J. Miller, B. Howe, "Developing Realistic Capstone Projects in Conjunction with Industry", Proceedings of the ACM SIGITE Conference on Information Technology Education, Destin, Florida, USA, October 2007.
- [3] D. Lange, R. Ferguson, P. Leidig, "An Update on the Use of Community-Based Non-Profit Organizations in Capstone Projects", Proceedings of the ACM SIGCSE Conference on Innovation and Technology in Computer Science Education, Darmstadt, Germany, June 2011.
- [4] M. Murray, "Implementing a Software Development Production Environment for Student Use: Advantages and Challenges", Journal of Computing Sciences in Colleges, December 2012.
- [5] T. Nurkkala and S. Brandle, "Software Studio: Teaching Professional Software Engineering", Proceedings of the ACM SIGCSE Conference, Dalas, Texas, USA, March 2011.
- [6] D. Stearns, S. Meldal, C. S. Turner, "Ten Pounds in a Five Pound Sack: Providing Undergraduate Software Engineering Students with Technical Management Experience", Proceedings of the international Conference on Engineering Education, Oslo, Norway, August 2000.
- [7] D. Stearns, J. Dalbey, C. Turner, T. Kearns, "Report on a Capstone Project Involving a Hundred Students, for an Industrial Partner", Proceedings of the international Conference on Engineering Education, Valencia, Spain, July 2003.
- [8] C. S. Turner, G. Fisher, D. Stearns, "Learning Software Engineering by Doing: Progress Report on a Capstone Sequence Involving Student Managed Teams", *Proceedings of the American Society for Engineering Education, Pacific Southwest Section*, Stockton, California, USA, April 2004.
- [9] Vu, Frojd, Shenkel-Therolf, Janzen, "Evaluating Test-Driven Development in an Insustry-Sponsored Capstone Project", 6th International Conference on Information Technology: New Generations, Las Vegas, Nevada, USA, April 2009.
- [10] H. Ziv and S. Patil, "Capstone Project: From Software Engineering to Informatics", Proceedings of the IEEE Conference on Software Engineering Education and Training, Pittsburgh, Pennsylvania, USA, March 2010

Interactive Web Activities for Online STEM Learning Materials

Alex Edgcomb and Frank Vahid
Department of Computer Science and Engineering
University of California, Riverside

Abstract

We are developing a repository of parameterized interactive web activities to aid in learning STEM (Science, Technology, Engineering, and Math) concepts. Much web-based material today, including online textbooks, online tutorials, and MOOCs (massive open online courses), include quiz-like activities to support interaction with the user. Varied customizable interactive activities, such as drag-and-drop definition matching, or shooting or navigation games driven by quiz-like questions, are provided for free on various sites or for a fee by commercial firms. Quiz-like activities merely scratch the surface of the power of web-based learning. We have found that learning STEM concepts requires more-specific activities that allow for exploration and tinkering-with a concept to support bottom-up learning, such as a tool that allows tinkering with a binary-to-decimal converter or an equation plotter. Such tools can be developed for HTML5 via custom Javascript and CSS programs. Our goal is to create a repository of parameterized customizable activities that authors can use without requiring Javascript/CSS expertise. We have developed several activities, all in HTML5, originally for introductory computer programming concepts. We discuss how those activities can be generalized and thus be made applicable to a wider variety of STEM topics, such as math, physics, or chemistry. Our goal is to create a repository of approximately 100 STEM-focused activities that web-based material authors can instantiate to create powerful web-based learning materials.

Introduction

STEM (Science, Technology, Engineering, and Mathematics) disciplines tend to involve challenging concepts, the learning of which can be enhanced by students performing activities related to the concepts – learning by doing. Lacking the ability for interactivity, traditional textbooks resort to longer explanations and series of drawings. Porting existing textbooks to electronic formats lowers costs and may increase access modes but does not capitalize on the web's potential for interactivity. Supplemental interactive activities has been done but may increase the burden on the student if not accompanied by decreases in excessively-large textbooks, class notes or Powerpoints, and other materials. Carefully planned interactive web activities can potentially decrease the need for lengthy written materials and thus improve learning.

This paper describes several types of interactive web activities developed for an introduction to programming course, namely binary-to-decimal converter, interactive inheritance tree, equation plotter, swap sorter, and quick sorter. The eventual goal is to create many tens of such activities, parameterized so that they can be reused across STEM disciplines.

Background

STEM students prefer to experience specific cases of a concept, such as sorting a list of random numbers, then work up to a general principle^{1,4,5,6}, such as an algorithm for sorting any list of numbers. Interactive activities provide a student with specific cases of a concept that can be explored and tinkered-with to both learn a concept for the first time and refresh the understanding of a previously learned concept.

Interactive software has been shown by researchers to improve student outcomes in engineering²⁵, math⁸, and science². Wood²⁵ built an interactive program for engineering education that allowed a student to manipulate basic engineering math equations representing signal filters and simultaneously see the affects on many perspectives of the equation. ALEKS⁸ is a web-based interactive software for enhancing college algebra education that significantly improved the student exam performance in college algebra courses. Broschat² developed interactive software that allowed a student to manipulate electromagnetism equations and visualize in 3-D the shape of the electromagnetic forces, such as electric potential and the magnitude of the electric potential. Interactive software has also been shown to improve education with adults. Shaw²³ evaluated patient colonoscopy education by the overall comprehension and satisfaction of the colonoscopy patients, comparing traditional education and traditional education plus interactive software. Shaw found significant improvements in the overall comprehension and satisfaction when using interactive software.

Interactive web activities have been built to explain STEM-specific concepts, including data structures^{7,10,13} and algorithms¹⁷ for Computer Science undergraduates. Kloss¹³ built a tool that displays a binary tree of numbers from which a student can insert a number, delete a number, and search for a number. Mukundan¹⁷ built an activity that graphically and textually shows the difference between searching a graph via depth-first and breadth-first. The student builds the graph by clicking on any two nodes to create an edge between the two nodes.

Literally hundreds of tools support development of learning content, such as Kenexa¹², LearnerWeb Cap¹⁴, Microsoft Learning Development System (LCDS)¹⁶, ReadyGo²², and ToolBook²⁴, to name just a very few. Many such tools are highly-polished and target creation of corporate training materials. Extensive support is provided for creating quizzes, tree-structured content, and animations.

Web-based authoring tools have also been used to create educational content. For example, Inkling Habitat⁹ and Lectora Online¹⁵ support web-based integration of existing content like text, images, and videos. Some allow creation of games and other activities, e.g., ClassTools³ and Raptivity²¹. Various open-source tools exist to assist¹⁸.

Raptivity²¹ is software to build interactive web activities from customizable, general-purpose template activities. An example activity is a graphical book that can be loaded with pictures and text, in which the text can be automatically converted to audio or a voice recording can be played. Another activity is a graphical pyramid with a variable number of levels that describes a particular level with text and audio when that level is clicked. Since Raptivity's template

Figure 1: Binary-to-decimal converter activity allows students to toggle each bit of a binary number with a click and instantly show the decimal value.



activities are general enough for any discipline, the benefit to STEM-specific disciplines is limited, particularly in the way of feedback to the student.

Interactive Web Activities

Interactive web activities teach a concept via exploring and tinkering. The interactive elements are visually easy to identify using standard web interactive elements, such as shadowed buttons. The activities give instant feedback to the student allowing for rapid building and refinement of understanding. Web-based learning materials can consist of fewer words and more activities.

The following subsections describe initial interactive web activities that we originally developed for introductory computer programming material in C¹⁹ and C++²⁰. Also discussed are possible expansions to other STEM disciplines.

Binary-to-decimal converter

The binary-to-decimal converter activity teaches a fundamental concept in Computer Science that can also be applied to teach any number system. As shown in Figure 1, the activity contains 8 bits, which interact as buttons. The sum of the bits is a decimal value shown on the right. Below each bit is that bit's value as a decimal number. Below the bit's value as a decimal number is the bit's value as a power of 2.

When a student clicks a bit, the bit instantly toggles (from "0" to "1", or "1" to "0"), and the decimal value is instantly updated to the appropriate value. This activity quickly teaches a student how binary works and is a useful quick reference converting a binary number to decimal.

We have described binary-to-decimal numbers in a traditional textbook, requiring several pages. The web-based material instead consists of a single paragraph and the tool. Our initial experience is that the tool enables students to construct their own understanding of how each digit contributes to the decimal amount. Anecdotally, we have had students as young as 14 years old experiment with the tool and within minutes they understand the concept.

A similar tool, wherein buttons are pressed to include or exclude an item, could potentially assist with other STEM topics. The tool could be parameterized to allow each button to toggle between include and exclude states (rather than 0 or 1), or could allow selection of any number (e.g., 0-99). Each digit can be associated with different values, rather than 1, 2, 4, 8, etc. Buttons could be inserted anywhere within a string of text. One example usage would be in understanding how

Figure 2: Interactive inheritance tree activity contains (a) an inheritance tree, (b) pseudocode that is color-matched to the inheritance tree, and (c) actual code that is textually-matched to the pseudocode and inheritance tree.

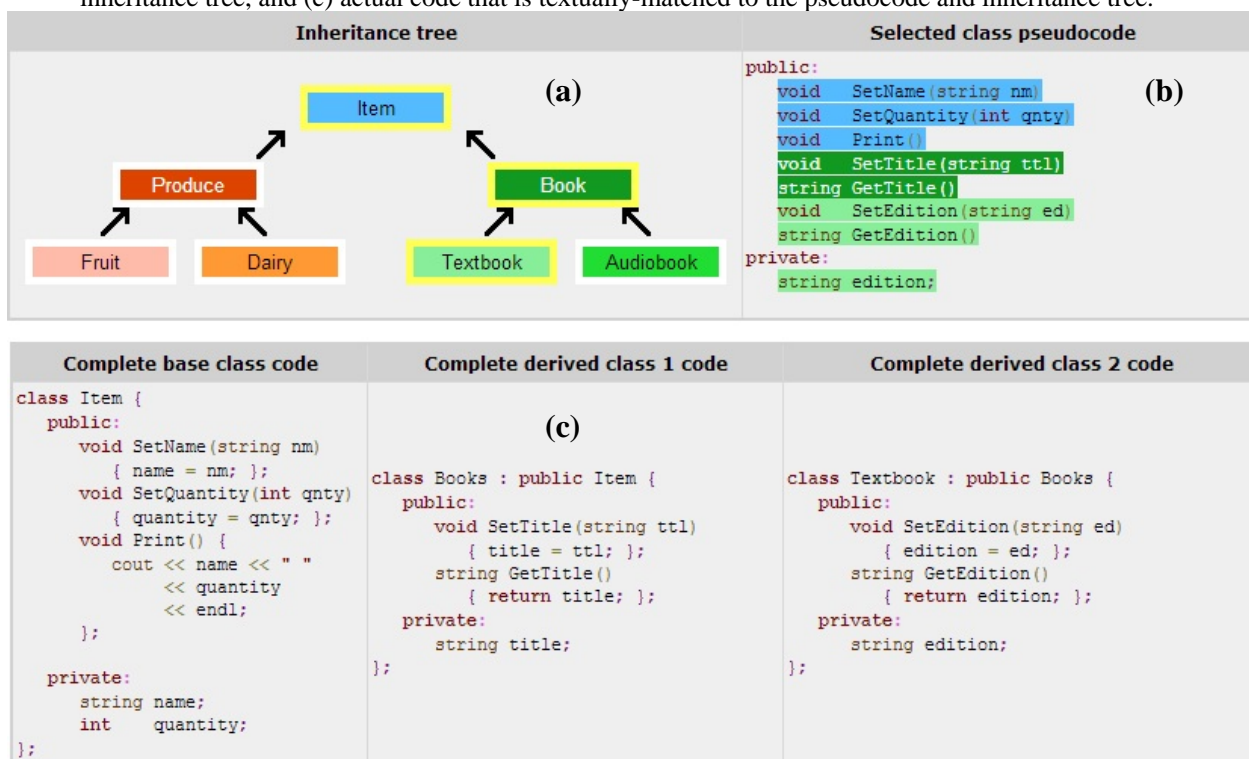

a polynomial is impacted by constants for a given x value; the user could click on constants, e.g., $y = _x^2 + _x + _$, where each $_$ is a button whose value is selectable. For a given x (which could be modified by the user), the user can vary the values and see the difference in output value. Alternatively, buttons could represent the resistance of a parallel circuit, and the result could represent the current for a given voltage.

Interactive inheritance tree

Inheritance trees are used across many fields to show the relationship of objects. The interactive inheritance tree activity teaches the concept of inheritance in three ways: entirely visually, partially visually and partially textually, and entirely textually. The three ways show the same idea in different contexts. In Computer Science, a class, which consists of data and functions, may inherit data and/or functions from another class.

The activity includes an inheritance tree of classes, shown in Figure 2(a), that is entirely visual. The inheritance tree has arrows pointing from one class to the inherited class. When a user clicks on a class in the tree, that class and all the classes which are inherited become highlighted, thus showing the lineage of inheritance. Each class' background color is distinct yet similar to the inherited class' background color, e.g., the class "Textbook" is light green while "Book" is dark green.

The activity also includes pseudocode, shown in Figure 2(b), that is partially visual and partially textual. To the right of the tree, the clicked class' data and functions are shown as pseudocode, including the inherited data and functions. Each data and function is colored with the distinct

Figure 3: Equation plotter activity contains (a) a graph and (b) check-boxes for equations.

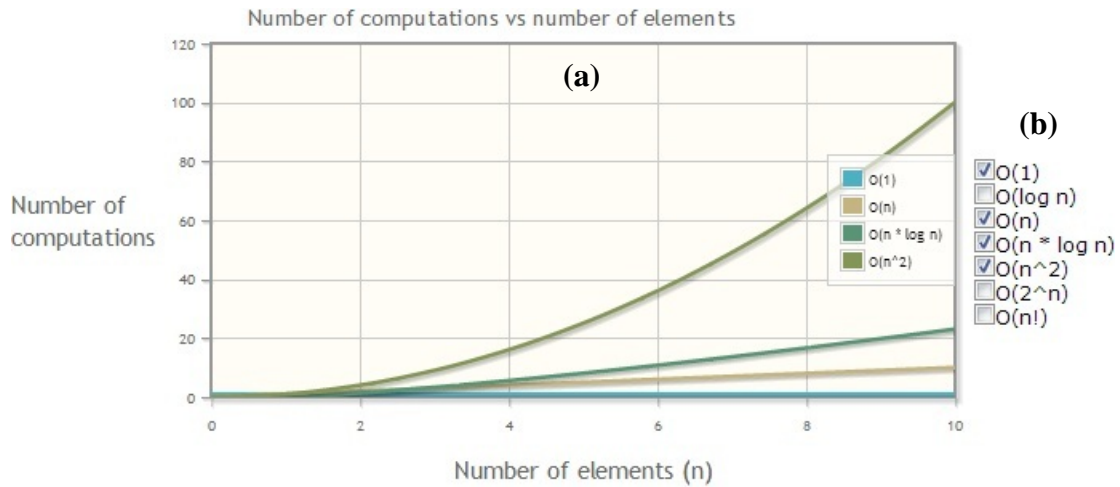

background color of the originating class, e.g., the function "SetEdition" is colored the same as the class "Textbook", while the function "SetTitle" is colored the same "Book". This coloring makes associating data and functions with the original class fast and easy.

Lastly, the activity includes actual code, shown in Figure 2(c), that is entirely textual. Below the tree, the actual code is shown that describes the clicked class and the classes inherited by the clicked class. Each class' code is contained in a different column and each column has a header name describing the relationship of the classes.

The parameterized version of the tool could allow for an arbitrary number of objects in the tree and with an arbitrarily number of connections, including multiple inheritance. Also, each object could be represented by a picture, text, or other chosen media. The color-coded information to the right of the tree would be optional and, if chosen, automatically generated based on the selected object and that object's inheritance. A pre-set list of rules for automatically generating the color-coded information would be built based on needs from other disciplines. The entirely textual area would be optional and be capable of a chosen media.

Equation plotter

Equation plotting and comparing are common activities in engineering education. The equation plotter activity visually shows the relative difference between equations plotting the equations on the same graph. The equations shown can be instantly changed by a student. The equations in Figure 3 are common computational complexities in Computer Science.

The equation plotter activity, shown in Figure 3, contains a graph (generated using jqPlot¹¹) and check-boxes for equations. The graph shows an equation when the respective check-box is checked. Otherwise, the equation is not shown. The y-axis of the graph is updated to optimize the viewing of the equations, which makes seeing the difference between equations clear. In particular, all of the equations are entirely shown and the equations dictate the range of the y-axis. The y-axis minimum and maximum values are updated based on the equations that are checked, e.g., if only O(1) and O(n²) were checked and the x-axis maximum is 10, then O(n²)

Figure 4: Swap sorter activity intuitively teaches structured sorting of numbers, from smallest on the left to largest on the right. (a) A student can swap two numbers by highlighting the two numbers then clicking "Swap values". (b) The current playtime and best sorting time are shown in seconds.

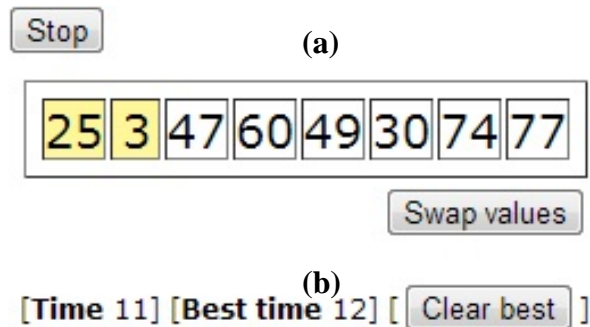

would produce the largest y-value at 100 so the y-axis range maximum would be at least 100. The y-axis minimum and maximum range also stay relatively close to the smallest and largest equation values, respectively. For example, in Figure 3, even though $O(n^2)$ has the largest y-axis value of 100, the graph's maximum y-axis value is 120.

The equation plotter activity scales well with the number of equations since the student can control which equations are displayed. Also, when an equation with particularly large y-axis value causes the remaining equations to appear identical, such as the affect of $O(n!)$ on the other equations in Figure 3, the student can remove the overbearing equation.

The activity can be parameterized to accept instructor and/or student-defined equations. Controls for zooming in and out of the graph are a potential parameter, as well as the option for alternative graph types including 3D and bar graphs. Further analytics of the equations could be included.

Swap sorter

The swap sorter activity introduces structured sorting of numbers, in this case from smallest to largest. The activity limits the student's controls to be analogous to instructions given to a computer via code. Thereby, intuitively teaching a student how to program a computer to sort numbers, which is a common task for novice and advanced programmers.

The list of numbers and sorting controls are shown in Figure 4(a). When a student clicks the "Start" button, which changes to the "Stop" button as shown in Figure 4(a), a list of randomly generated numbers appear. The student is instructed to sort the numbers by swapping values. Two values are swapped by highlighting the two values then clicking "Swap values". The swap sorter activity ends when the numbers are sorted from smallest on the left to largest on the right, or if the student clicks the "Stop" button. When the activity ends, the student can restart the swap sorter with a new list of randomly generated numbers.

The student is encouraged to play again to beat his or her best sorting time. The current playtime and best sorting time are shown in seconds, as shown in Figure 4(b). The best time is updated when the swap sorter activity ends if the current playtime is smaller than the best time. The best time can be cleared with the "Clear best" button.

Figure 5: Quick sorter activity intuitively teaches the quick sort algorithm. (a) The student must select all values in the current window of values that are smaller than the pivot value, then click the "Partition" button. Highlighted values are blue, while unhighlighted are yellow. (b) The previous windows are displayed to visualize the recursion.

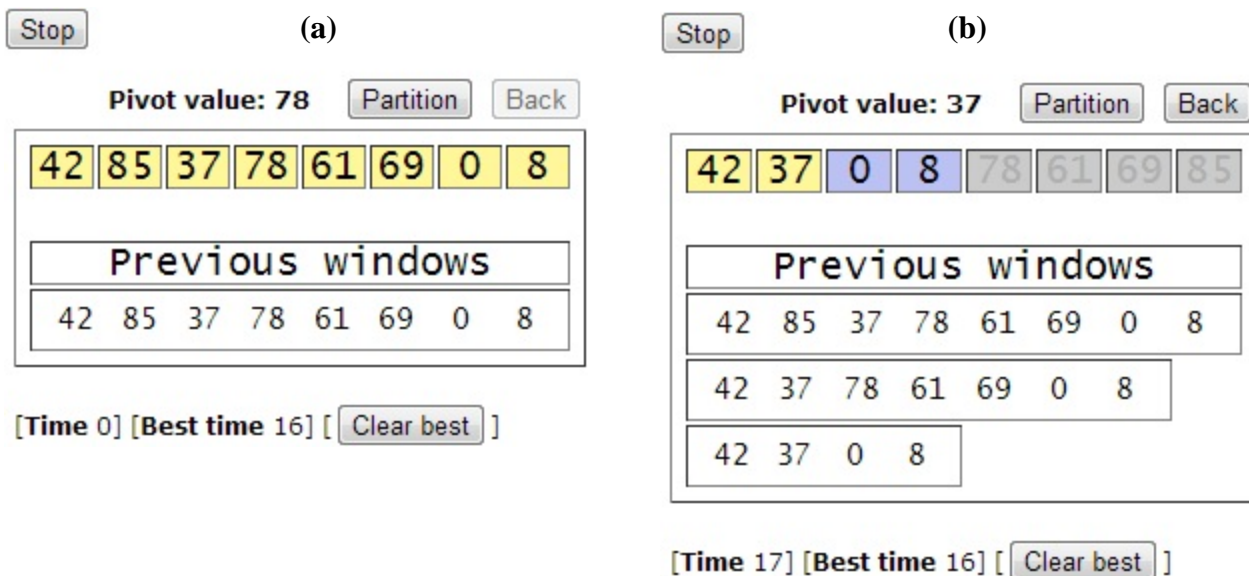

A similar tool, in which a list can be interacted with by selecting elements in the list and manipulating the selected element with a button, could assist in other STEM disciplines. The tool could be parameterized to allow elements to be represented by any media, and could allow for the button affects on the list to be selected from a set of pre-loaded behaviors, including swap. One example usage is a parallel resistor simulator. Each element in the list represents a resistance. The simulator has a given input voltage and computes an output voltage based on the selected resistances when the student clicks the button.

Quick sorter

The quick sorter activity intuitively teaches the quick sort algorithm by constraining the student controls to be analogous to computer instructions via code. Quick sort partitions a window of values into two parts: (1) values smaller than the pivot value and (2) values greater than the pivot value. Then, repeats the partitioning on each part until each part has only one value. The pivot value is the value located at the middle of the current window.

When the student clicks the "Start" button, which changes to the "Stop" button shown in Figure 5(a), a list of randomly generated numbers appears, and the pivot value is automatically calculated and displayed. The student must highlight the values smaller than the pivot value, then click the "Partition" button. Highlighted values are blue. If a value is mistakenly highlighted or unhighlighted when "Partition" is clicked, then a pop-up appears indicating the specific mistake. Otherwise, the partition proceeds with smaller values on the left and larger values the right. The larger values are grey and disabled, as shown in Figure 5(b), while the smaller values are further partitioned. Partitioning stops when the current window contains only one value.

The previous windows are displayed automatically and updated after each partition. The "Previous windows" hierarchically shows the recursive partitioning, which connects the idea of

partitioning a specific window with the recursive nature of quick sort. The "Back" button steps back one partition per click, which strengthens student's understanding of the specific window and recursive nature connection.

Due to the quick sorter activity having more complexity than the swap sorter, the amount of interactivity was extended to include the ability to step backwards, the ability to disable elements in the list, and a history of selectable elements in the list. These inclusions could be added as additional parameters to the parameterized swap sorter tool. One example usage is a limited-resistor allocation game in which the user must allocated a limited number of resistors to three circuits. Each circuit has a given input voltage and a required range of output voltages. The student must determine which combination of resistors to put in parallel for each circuit. The student solves the game by iteratively selecting which resistors will be applied to each circuit. The back button would be used to step-back to a previously applied circuit in the case that a needed resistor is being used by a previous circuit. The previous windows should show the resistor grouping for each circuit.

Conclusion

We described in detail 5 interactive activities, namely binary-to-decimal converter, interactive inheritance tree, equation plotter, swap sorter, and quick sorter. The activities have been implemented for the web and are already available for Computer Science education. Furthermore, we discussed the reuse of the activities for other engineering disciplines. Interactive activities benefit education by supplementing textual explanations with activities to explore and tinker-with, and allow for shorter worded explanations. STEM educators, who are not necessarily expert programmers, need to be enabled to develop interactive activities. Our approach is to build a repository of parameterized tools that allow for high-levels of customization for STEM topics. We plan to refine the repository by applying the parameterized tools across STEM education.

Bibliography

1. Bransford, J. How people learn: Brain, mind, experience, and school. National Academies Press, 2000.
2. Broschat, S.L. Interactive software for undergraduate electromagnetics. Education, IEEE Transactions, Volume 36, No. 1, pgs. 123-126, 1993.
3. ClassTools. <http://www.classtools.net/>. January 2013.
4. Felder, R.M. "Reaching the second tier." Journal of College Science Teaching, Volume 23, No. 5, pgs 286-290, 1993.
5. Felder, R.M., D.R. Woods, J.E. Stice and A. Rugarcia. "The future of engineering education II. Teaching methods that work." Chemical Engineering Education, Volume 34, No. 1, pgs 26-39, 2000.
6. Felder, R.M. and L.K. Silverman. "Learning and teaching styles in engineering education." Engineering education, Volume, 78, No. 7, Pgs 674-681, 1988.
7. Franco, J. <http://www.ece.uc.edu/~franco/C321/html/RedBlack/redblack.html>. January 2013.
8. Hagerty, G. and S. Smith. Using the web-based interactive software ALEKS to enhance college algebra. Mathematics and Computer Education, Volume 39, No. 3, pgs 183-194, 2005.
9. Inkling Habitat. <https://www.inkling.com/habitat/>. January 2013.
10. Jarc, D. J. <http://nova.umuc.edu/~jarc/idsv/lesson1.html>. January 2013.
11. jqPlot. <http://www.jqplot.com/>. January 2013.
12. Kenexa. http://www.outstart.com/outstart_lcms.htm. January 2013.

13. Kloss, J. <http://www.cs.jhu.edu/~goodrich/dsa/trees/btree.html>. January 2013.
14. LearnerWeb Cap. <http://www.maxit.com/learn/>. January 2013.
15. Lectora. <http://lectora.com/online-e-learning/>. January 2013.
16. Microsoft Learning Development System (LCDS). <http://www.microsoft.com/learning/en/us/lclds-tool.aspx>. January 2013.
17. Mukundan, R. <http://www.cosc.canterbury.ac.nz/mukundan/dsal/GraphAppl.html>. January 2013.
18. OpensourceLearning. <http://blog.efrontlearning.net/2010/10/open-source-authoring-tools-for-e.html>. January 2013.
19. Programming in C. <http://prog.c.zyante.com/>. January 2013.
20. Programming in C++. <http://pcpp.zyante.com/>. January 2013.
21. Raptivity. <http://www.raptivity.com/>. January 2013.
22. ReadyGo. <http://readygo.com/>. January 2013.
23. Shaw, M.J., T.J. Beebe, P.A. Tomshine, S.A. Adlis, O.W. Cass. A randomized, controlled trial of interactive, multimedia software for patient colonoscopy education. *Journal of clinical gastroenterology*, Volume 32, No. 2, pgs 142-147, 2001.
24. ToolBook. <http://www.sumtotalsystems.com/products/toolbook-elearning-content.html>. January 2013.
25. Wood, S.L. A new approach to interactive tutorial software for engineering education. *Education*, IEEE Transactions, Volume 39, No. 3, pgs 399-408, 1996.

Using Arduino Microcontroller Based Robot Projects to Teach Mechatronics in a Hands-On Mechanical Engineering Curriculum

**Andrew Siefert, Jonathan Hoy, Keith Christman,
Dr. Kevin R. Anderson, P.E.
California State Polytechnic University at Pomona
Mechanical Engineering Department
Mechatronics and Robotics Laboratory
3801 West Temple Ave, Bldg. 17-2353
Pomona, CA 91768 USA**

Abstract

The use of ARDUINO microprocessors allows for a very top level approach to teaching Mechatronics. The focus on this paper is to motivate the use of ARDUINO microcontrollers to teach Mechatronics and Control Systems in Engineering Education. This is not a research paper per say, rather it is a detailed explanation of an example of “hands-on” pedagogy. The goal of this paper is to merely share the outcomes of an experiential learning environment with the academic community. This paper will present the results of using ARDUINO microcontroller based projects to teach a senior level Mechanical Engineering Mechatronics/Robotics course. The use of "hands-on" learning is documented in this paper via the teaching of Mechatronics through the capacity of having students design/fabricate/engineer/program robot to navigate a maze autonomously. Use of Mechatronics, i.e. a synergy of control systems, data acquisition and sensors, kinematics of machinery, and programming is detailed in this paper using student projects as the learning/instructional vehicle. Rubrics for assessment of such a "hands-on" course will also be shared in this paper.

Introduction

Mechatronics is defined by Bolton¹ as “Electronic Control Systems in Mechanical and Electrical Engineering”. We have been teaching a senior level technical elective as ME 499/L “Mechatronics/Lab” at California State Polytechnic University at Pomona (Cal Poly Pomona) in the Department of Mechanical Engineering for over the last 15 years. Over this timeframe as technology has advanced, so has the demand to teach the course at a cost effective level for the students. Faced with economic downturns, the university has forced its faculty to come up with creative alternatives to teaching such state-of-the-art technical electives as robotics in order to fill the need of making our graduates competitive as they enter the industrial workforce and/or graduate school. To this end, over the last couple of years, the faculty teaching robotics and control systems curriculum in the Mechanical Engineering Department at Cal Poly Pomona have devised a series of projects based around using the ARDUINO series of microcontrollers. This paper will describe the use of Arduino Microcontrollers to teach Mechatronics address the following ASEE-PSW 2013 objectives: multidisciplinary - interdisciplinary projects/classes, experiential learning, project-based learning and innovative pedagogies and uses of current and emerging technologies in the classroom.

The Arduino based Mechatronics course taught as ME 499/L at Cal Poly Pomona utilizes a course project and competition. The equipment used by each student varies, but a baseline kit provided by the Robot Shop¹ was used for commonality. This project based course is similar to others used for educational purposes including, Anderson and Jones². Other noteworthy studies which use a similar pedagogy can be found in the literature including the works of Consi³ and Wang *et al.*⁴ The current paper discusses similar pedagogy and how it is implemented via the “hands-on” learning philosophy which Cal Poly Pomona is well known for.

Robot Equipment Used

For the projects, a basic kit was selected. This was done to keep the cost to a minimum. The equipment used is listed below. Many of the components listed are referenced in the compendium reference books given by Waren *et al.*⁵, and McComb⁶. Additional on-line resource which prove valuable when teach Mechatronics include the Robot Shop⁷ at <http://www.robotshop.com/> and Trossen Robotics⁸ at <http://www.trossenrobotics.com/c/arduino-robotics.aspx>. The equipment used to build the robot was as follows:

- DFRobotShop Rover V2 Basic Kit - \$94.99 (www.robotshop.com)
- DFRobotShop Rover Arduino Board (Arduino Uno R3 + Motor Controller)
- Tamiya Track and Wheel Kit
- Tamiya Dual Motor Drivetrain Kit
- Mounting Brackets
- Sharp Short-Range Infrared Proximity Sensor (x3) - \$13.95 ea. (www.sparkfun.com)
- ADJD-S311-CR999 Color Sensor + Breakout Board - \$14.95 (www.sparkfun.com)
- 2-Terminal Microswitch (x2) - \$1.50 ea. (www.sparkfun.com)
- PerfBoard Sheet - \$3.50 (Radio Shack)
- Miscellaneous Mounting Hardware/Electronic Components
- Overall cost approximately \$200

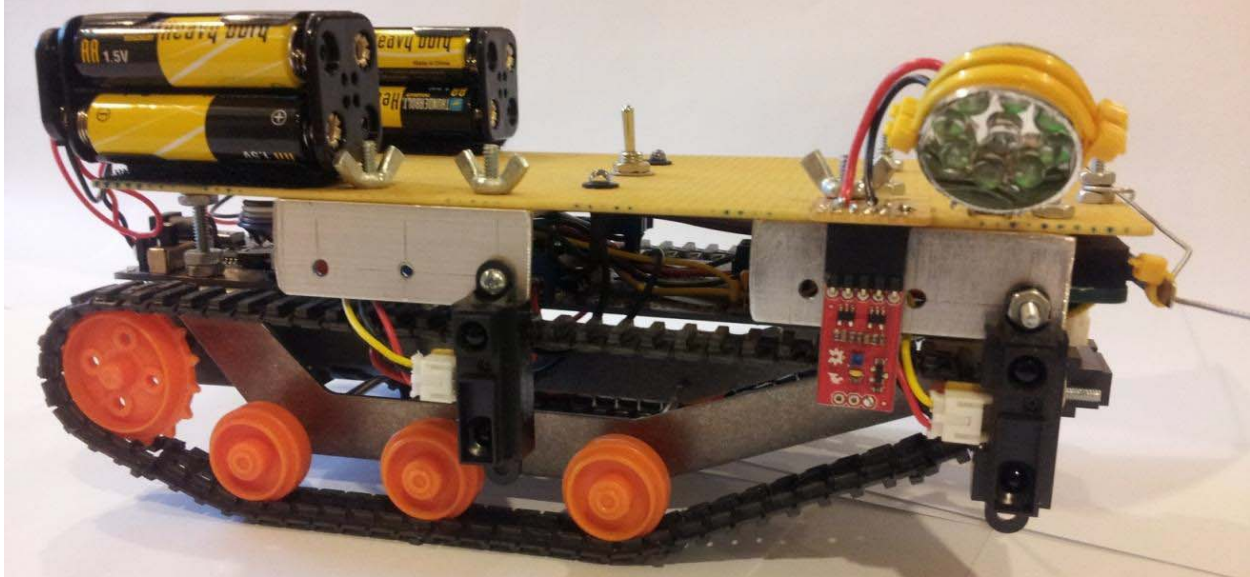

Figure 1- Completed Maze Robot used in Mechatronics ME 499

A novice knowledge of the C programming language is required to be up and running when working with the ARDUINO. A valuable reference to this end is given by Margolis⁹.

Course Learning Objectives

The learning objectives of the ME 499 course were

1. Learn how to design, build, program and test an autonomous maze-solving robot
2. Learn how to condition, process, and calibrate sensor data for use in autonomous control logic
3. Learn how to troubleshoot and tune control logic for optimum operation

This robot was designed to find the end of a conventional maze by following a single wall until it finds a red flag. To accomplish this, the robot uses three analog infrared distance sensors and one digital color sensor. The robot is based on the DFRobotShop Rover tracked robot kit. The kit consists of an expanded Arduino board with built-in motor control, an aluminum frame, a set of wheels and tracks, two motors and a dual-drive gearbox as shown in Figure 2. This kit was employed with minimal hardware modifications besides sensor mounting hardware and circuitry added to the built-in prototyping area.

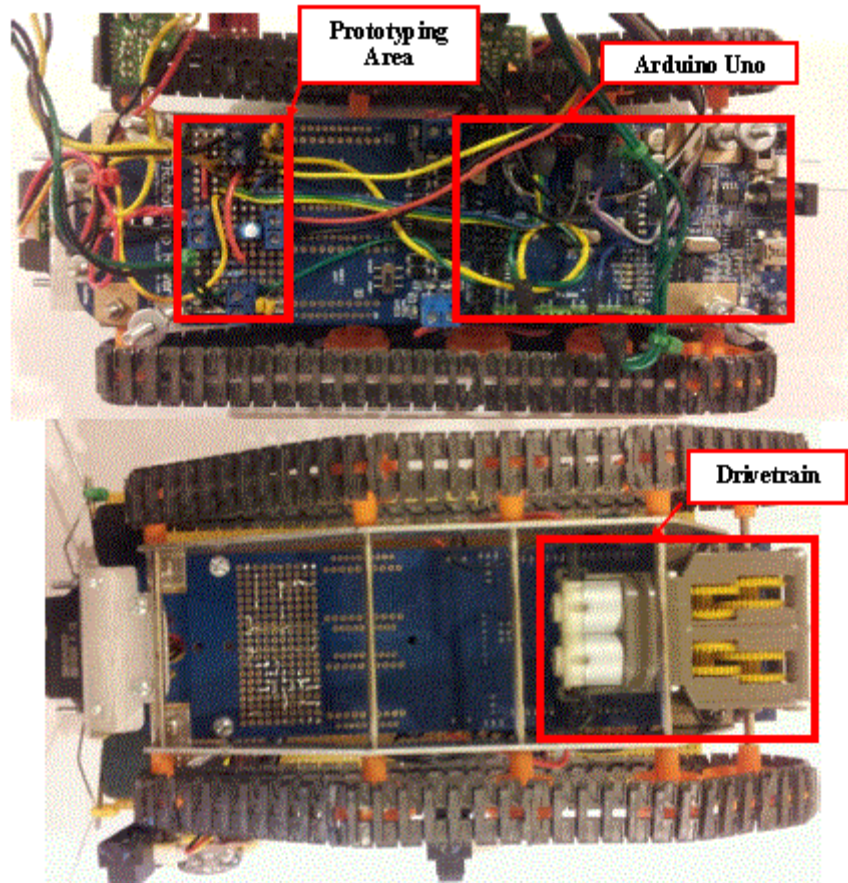

Figure 2- The Main Board on the Finished Robot (Top & Bottom views, respectively)

Anatomy of the Arduino

The Arduino Uno is a microcontroller board based on the ATmega328 (High Performance, Low Power AVR® 8-Bit Microcontroller, Advanced RISC Architecture). It has 14 digital input/output pins (of which 6 can be used as PWM outputs), 6 analog inputs, a 16 MHz ceramic resonator, a USB connection, a power jack, an ICSP header, and a reset button. The Arduino contains everything needed to support the microcontroller; one simply connects it to a computer with a USB cable or powers it with a AC-to-DC adapter or battery to get started. The Uno differs from all preceding boards in that it does not use the FTDI USB-to-serial driver chip. Instead, it features the Atmega16U2 programmed as a USB-to-serial converter. The ATmega328 has 32 KB. It also has 2 KB of SRAM and 1 KB of EEPROM. Revision 3 of the board has the following new features; 1.0 pin out: added SDA and SCL pins that are near to the AREF pin and two other new pins placed near to the RESET pin, the IOREF that allow the shields to adapt to the voltage provided from the board. Other relevant technical specification of the Arduino include the following:

- Microcontroller=ATmega328
- Operating Voltage=5V
- Input Voltage =7-12V
- Input Voltage (limits)= 6-20V
- Digital I/O Pins=14 (of which 6 provide PWM output)
- Analog Input Pins=6
- DC Current per I/O Pin=40 mA
- DC Current for 3.3V Pin=50 mA
- Flash Memory=32 KB (ATmega328) of which 0.5 KB used by bootloader
- SRAM=2 KB (ATmega328)
- EEPROM= 1 KB (ATmega328)
- Clock Speed=16 MHz

Sensors and Control

The infrared sensors are the robot's primary method of sensing the maze geometry. One sensor is mounted on the front and two on the side of the robot which faces the maze wall (Figure 3). The one on the front serves to detect walls and other obstacles directly in the robot's path so it can negotiate around them. The sensors on the side detect the wall being followed. The side sensors are aligned vertically so they may better detect sudden changes in wall range caused by a corner. The sensor at the front corner of the robot is used to judge the error between the robot's actual distance from the wall and the desired distance.

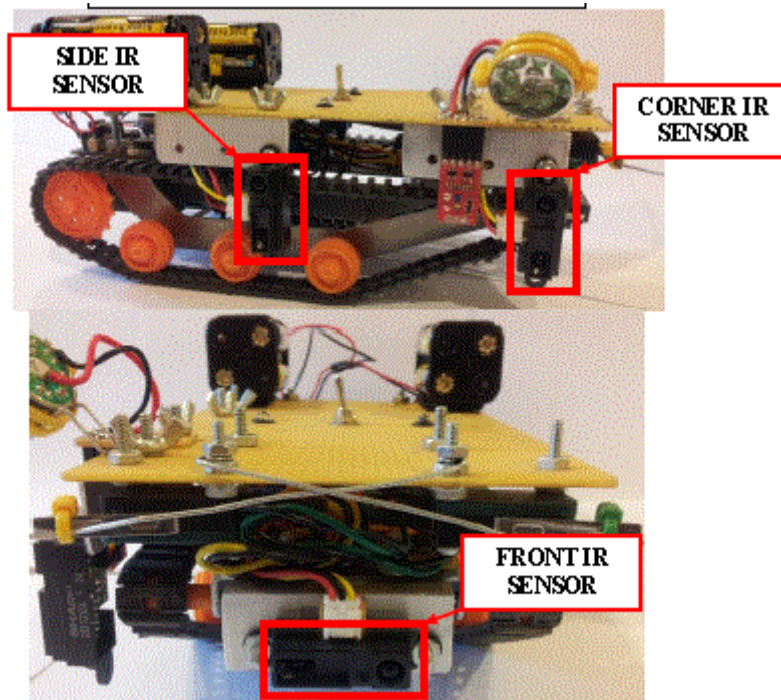

Figure 3- IR Sensors

This error value is passed to a PID algorithm controlling individual motor speed on each side of the robot which attempts to keep the robot at a set distance from the wall. The PID influences both motors simultaneously, always decreasing the speed on one and increasing the speed on the other. The motors have a nominal PWM duty cycle of 200, and the PID value adds to or subtracts from it. Note that the PID is limited to a maximum value of 55 to avoid it influencing one motor more than another. A diagram of the PID control algorithm can be seen in Figure 4.

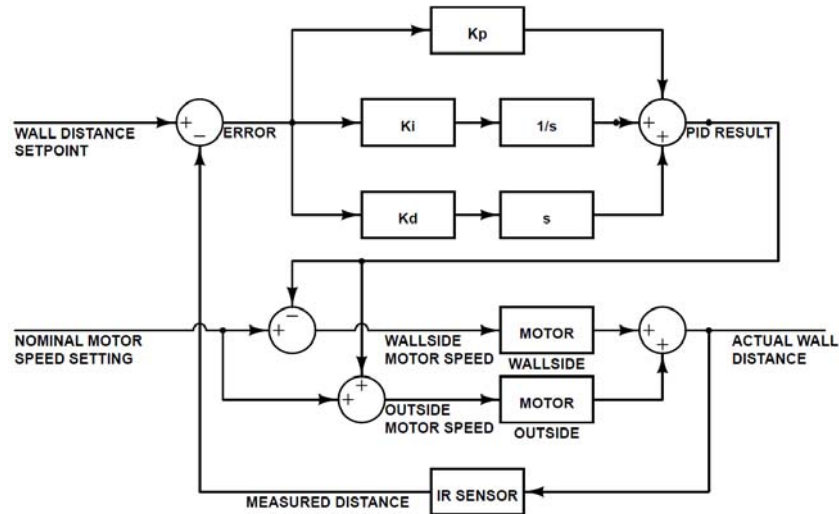

Figure 4 – Control System Block Diagram

The other IR sensor on the side of the robot simply aids in turning by using range measurements to determine inner track speed. To remove noise from the output signal of the sensors, a $100\ \mu\text{F}$ capacitor was placed across the supply voltage to filter out Arduino supply noise. The sensor outputs are also passed through 100 Hz passive low pass filters wired into the prototyping area of the main board. Since the voltage output of the IR sensors varies non-linearly with object range [1], values were taken from each sensor at ranges from 1.5" to 8.0" in 0.5" increments. These values were used to generate calibration curves for each sensor. The two sensors on the side of the robot yielded nearly identical curves and could therefore use the same calibration equation in the program. The front sensor, however, required its own calibration equation in order to obtain accurate results. The calibration curves can be seen in Figure 5.

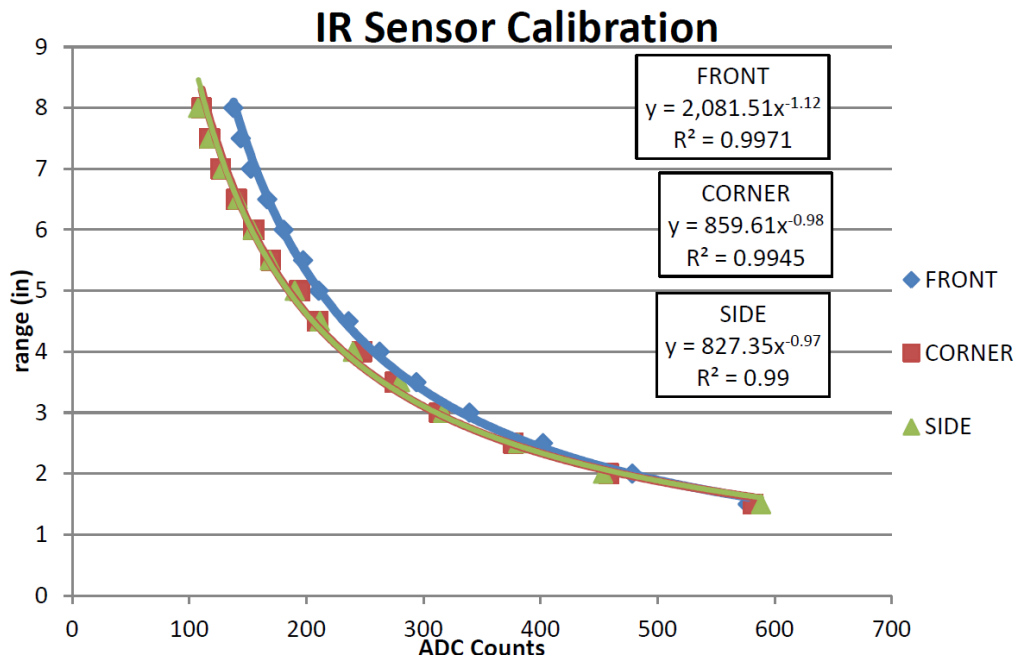

Figure 5– IR Sensor Response Calibration Curve

The robot also has two bump switches on the front of it for collision detection. The switches are connected to bumpers made from bent paper clips to augment their sensing area as shown in Figure 6. These switches are each wired to pins on the Arduino such that when a switch is tripped, the robot will reverse, turn away from the side that detected contact, and resume normal operation. In the early stages of development, switch bounce caused problems with detection. This problem was fixed by two 0.1 μF capacitors in parallel across the terminals of each switch, which served to filter out oscillations from switch bounce.

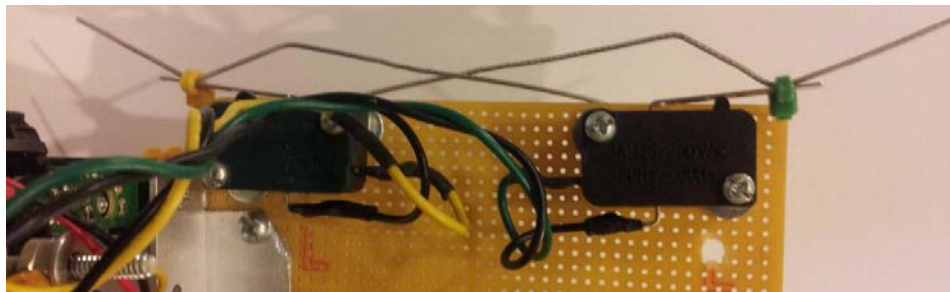

Figure 6– Bump Switches

The robot also has a color sensor to detect the maze start and end flags as shown in Figure 7. This sensor is digital; it has a series of data registers which can be read and written to over an I²C serial bus. Much of the code handling the I²C communication was taken from the open-source example code from SparkFun.com³. To obtain a color, the data registers for Red, Green, Blue, and Clear color values must be read. When the Arduino program starts, it initializes the sensor and calibrates it to a white surface. The program then stores values for the start (green) and stop (red) flags. During operation, the program continually polls the color registers and compares them to the stored values

for red and green. If it sees green, it instructs the robot to move. If it sees red, it instructs the robot to stop and idle. Note that the breakout board for this sensor has a built-in surface mount white LED illustrated in Figure 8. This LED is more than bright enough to allow for color sensing, but is mounted so close to the sensor itself that it drives all color registers to their maximum values if the surface being evaluated is more than 2 mm away from the sensor. Since this robot need to evaluate color at a distance of 2 inches, it was necessary to instead use a separate array of 9 white LEDs in a reflective housing to provide enough light to the surface without washing out the measurement. The LED array was taken from a broken flashlight and simply wired to a digital pin on the Arduino through a 30 Ω resistor to limit the pin current to 30 mA.

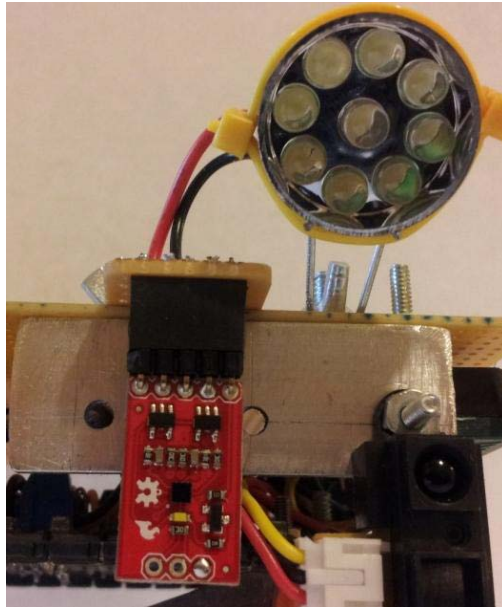

Figure 7– Color Sensing Unit

While building the project, it became immediately apparent the final robot should be able to follow either the left or right wall, as one may be preferable to the other depending on how the maze is configured. Normally, this would mean doubling the number of sensors on the robot, which would be prohibitively expensive and require a second microprocessor. Instead, the robot was designed and built such that all the sensors which detect the maze wall could be mounted quickly and easily on either side of the robot. A switch was also added to the top of the robot to allow the user to select which wall was to be followed, as well as two LEDs to inform the user as to which wall was currently selected as shown below in Figure 8. The typical budget for a project of this nature is on the order of approximately \$200 per robot.

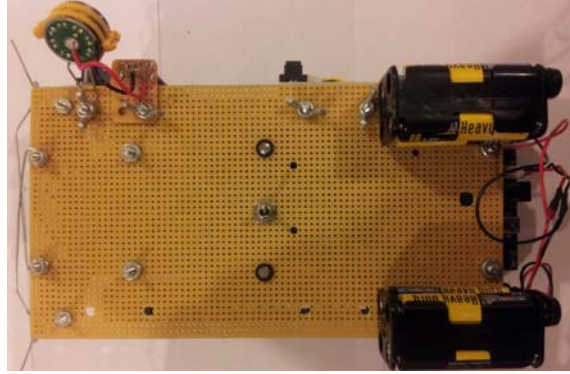

Figure 9– Finished Robot - Top View

When navigating the competition maze, in order to tell the start from the finish lines, a green sign (3 inches by 3 inches) was posted near the start of the course, and a red sign (3 inches by 3 inches) was posted on a wall of the maze marking the finish. Sensors were employed to perform bit map color scheme recognition, so that the robot would know green versus red, and therefore would be able to make a decision to start or finish. This fidelity is shown in Figure 10 and Figure 11, which are electrical schematic and flowcharts for the robot.

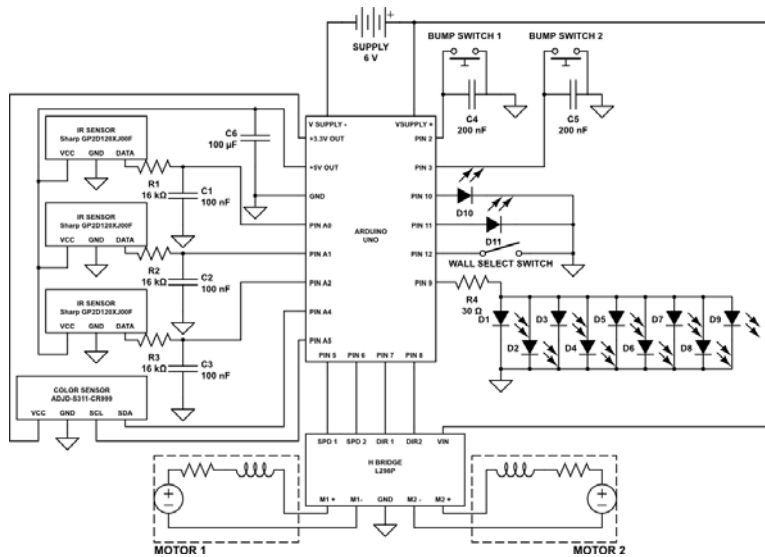

Figure 10– Robot Electrical Schematic

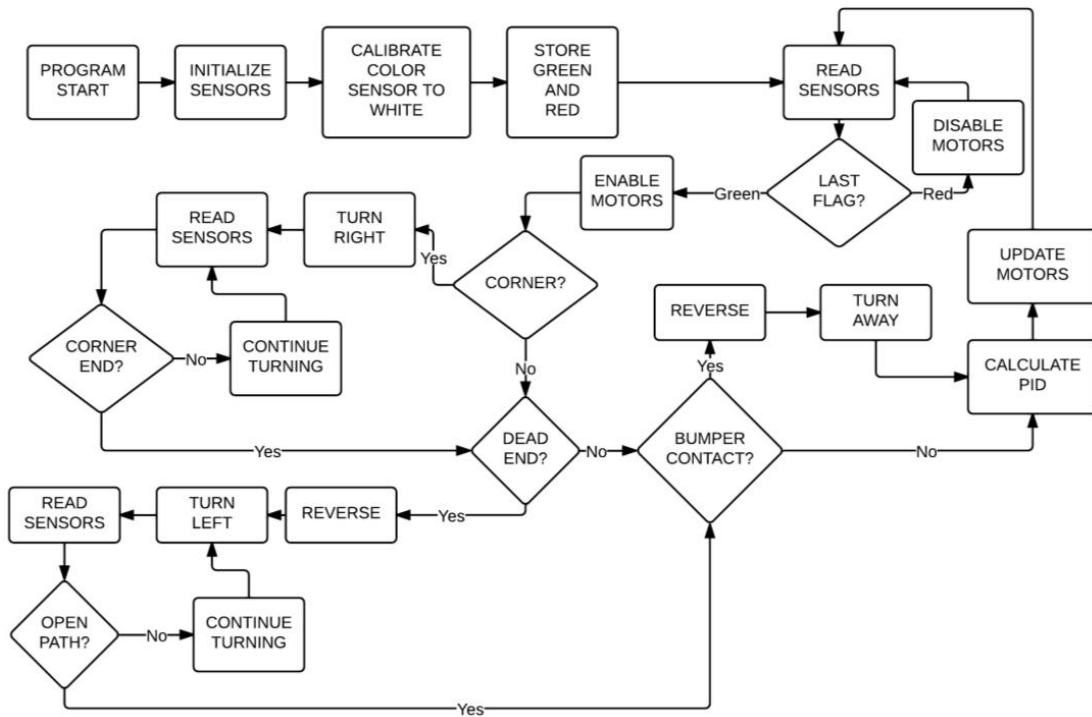

Figure 11– Robot Programming Flow Chart

Course Assessment

In order to assess the performance of each student enrolled in the ME 499/L “Mechatronics” course, a competition was held at the end of the quarter. The competition featured a maze which the robots had to navigate autonomously. Figure 13 shows the maze and two students preparing their robots to navigate the walls of the maze.



Figure 13– ME 499 Mechatronics Competition Maze

The maze is fabricated out of plywood and 2 inch by 4 inch stud walls, all painted white. The maze has a footprint of 8 ft by 8 ft, with a hinge built down the middle seam in order to fold it up

for storage and transport to robot competitions held abroad. The 2 inch by 4 inch stud walls can be removed and placed in various positions, thus the layout of the maze can be changed on-the-fly in order to exercise the true autonomous capability of the ARDUINO robots. White paint was selected, since the Mechatronics lab at Cal Poly Pomona has a large supply of fluorescent lighting, which may adversely affect the performance of photo-sensors when used with the robots. Figure 14 shows a robot in the maze as it makes a maneuver around a corner.

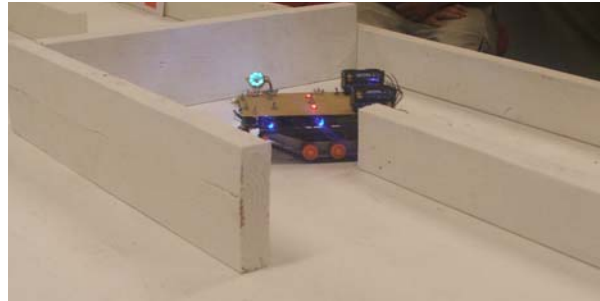

Figure 14– Robot Navigating the Competition Maze

Figure 15 shows a student preparing a robot to start the maze navigation.

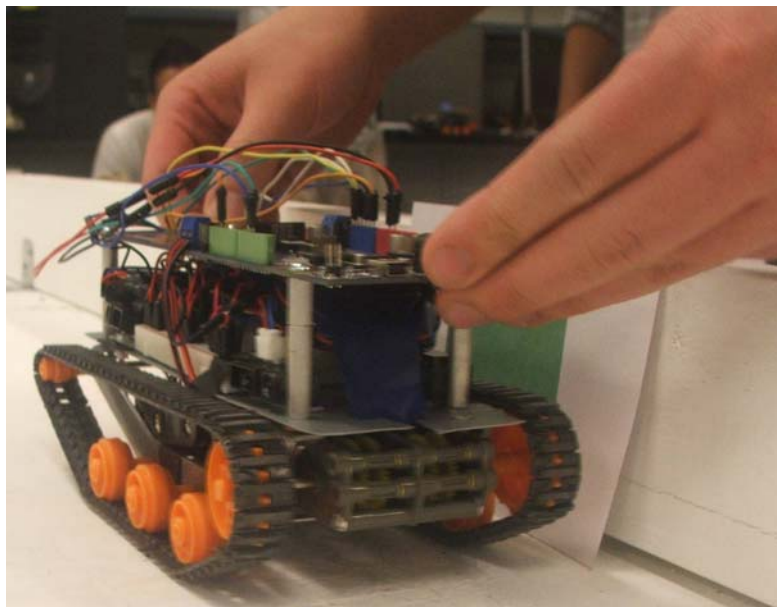

Figure 15– Robot Navigating the Competition Maze

The winner of the competition navigated the maze 35 seconds. Other speeds place second at 47 seconds, third at just over 2 minutes, and some robots did not complete the maze as required. The majority of student's robots finished the maze, however, 25% of the students did not have functioning robots at the end of the 10 week quarter. This course was taught with an industry based model, with schedule and cost the main drivers. The primary deliverables were a functioning robot and a technical write-up. To be successful, students needed to balance their academic workload, part-time jobs, family life and other things in order to make the robot come to fruition. Students engaged

in such projects should be aware that several hours of assembly, programming, de-bugging, etc. is paramount the success of such a project based course. In order to have a successful outcome, Engineering Educators need to be aware of these time commitments and cost restrictions when offering courses dealing with Mechatronics and/or Robotics. The rubric shown below in Figure 16 was used to assess the student's performance on the final paper write-up of the project.

ME 499 PROJECT REPORT & MAZE COMPETITION GRADING RUBRIC FALL 2012
 STUDENT NAME: _____

DIFFICULTY/COMPLEXITY/MATURITY OF THE ROBOT DESIGN	/20
ROBOT WORKS/KINDA WORKS/DOESN'T WORK	/15
USE OF CONTROL ALGORITHM	/15
TECHNICAL REPORT WRITING STYLE	/20
REPORT FORMATTING, I.E. FIGURES AND REFERENCES, ABSTRACT, ETC.	/30
TOTAL	/100

Figure 16– Grading Rubric for Robot White Paper Technical Report

The overall course grade awarded to the students in the ME 499 “Mechatronics” class consisted of a series of homework sets, comprising 30% of the grade, the robot project/competition which was 35% of the grade, and the final report which was 35% of the grade. These statistics are limited to the students who actually enrolled in the class and completed the maze. This is because of the industry based deadline oriented fashion in which the course was managed, i.e. deadlines such as successful completion of the maze were emphasized from the onset of the course. This approach was adopted in mind that students entering the work force and/or graduate school must be cognizant of deadlines and/or budget constraints when working on real-world projects, and they must also recognize that there are penalties when deadlines are missed. This type of instruction helps to address the life-long learning skills need to acquire in order to be successful in private industry and/or graduate school.

Summary

This paper has summarized the use of ARDUINO based projects in teaching a senior level Mechatronics course. The robot project selected was an autonomous navigation of a maze. This project posed a great challenge in terms of navigation, object avoidance, and sensing. Thus, it made for a synergy of subject typically found under the umbrella of a Mechatronics course project. A simple array of infrared sensors and bump switches used in robot outlined in this paper proved to be a viable solution to this project and was proven sufficient for navigating a maze by following a wall. Getting the color sensor to read correctly under all lighting conditions was difficult; ultimately, it required clever programming by the students and a dedicated array of bright white LEDs. It is worth mentioning, however, that this system is severely limited by its need to stay close to the boundaries of the maze. It can only traverse walls which are connected to one another, and therefore cannot reach walls or barriers which stand freely on their own ("islands"). If the end flag for the maze is placed on an island, this robot, in its current configuration, will never get there. Solving this problem requires camera imaging with object recognition, which requires far more computing power than an Arduino alone can deliver. Therefore, any significant improvement upon this robot would require either a much more powerful onboard computer or wireless communication with a laptop or other

high level computing device, neither of which could be implemented within the project budget. As it is, this robot can solve most conventional mazes with little trouble, and the process of its design and construction has been challenging and insightful. Assessment of the robot was culminating in the form of a maze competition.

Bibliography

1. Bolton, W., "Mechatronics", 4th Ed. Pearson, 2008, London.
2. Anderson, K., Jones, C. Autonomous Robotic Vehicle Design. *Proc. of the ASEE PSW Regional Conference, April 7-8, 2005, Loyola Marymount University.*
3. Consi, T., A Versatile Platform for Teaching Mechatronics. *Proc. of ASEE Annual Conference 2012.*
4. Wang, Y., Ault, C., Nakra, T., Salgian, A., Stone, M. The Outcomes of an Interdisciplinary Undergraduate Course Involving Engineering, Science and Arts, *Proc. of ASEE Annual Conference and Exposition 2011.*
5. Warren, J., Adams, J., and Molle, H. "Arduino Robotics", Springer Science and Media, New York, NY. 2011.
6. McComb, G. "Robot Builder's Bonanza," 4th. Ed., Mc-Graw-Hill, New York, NY, 2011.
7. The Robot Shop, <http://www.robotshop.com/> last accessed 1/28/13
8. Trossen Robotics, <http://www.trossenrobotics.com/c/arduino-robotics.aspx> last accessed 1/28/13
9. Margolis, M. "Arduino Cookbook", O'Reily Media, Inc., Sebastopol, CA, 2011.

Computer Aided Teaching and Learning in an Undergraduate Electromagnetics Class

Milica Marković

California State University Sacramento

Abstract

In this paper integration of commercial CAD programs in an introductory, undergraduate electromagnetics course at California State University Sacramento is presented. Matlab, Agilent's Advanced Design System (ADS) and Momentum are integrated in various activities throughout the semester. Students write Matlab code to visualize electromagnetic fields and waves and use Agilent ADS and Momentum to master transmission lines and design a microstrip patch antenna. The course requires students to integrate knowledge of advanced vector calculus, electromagnetic theory and computer programming to visualize fields and waves and to relate electromagnetics applications to engineering design. The intent of the class is to improve students cognitive and affective domains, by enabling them to use industry tools to experiment and develop their own understanding of concepts taught in an active learning environment.

Introduction

Electromagnetics is a standard, core course in the electrical, electronics and computer engineering curriculum. Electromagnetics is fundamental to understanding of many practical areas of electrical engineering: from operation and design of medical, office, industrial and military equipment; through design of sensors, circuits, PC boards; Electromagnetic compatibility, interference, signal integrity and radiation; to electromechanical systems, power generation, transmission and distribution. This fundamental relationship between electromagnetics and all branches of electrical engineering is usually difficult to relate to first-year electromagnetics students. Students perceive electromagnetics as an overly mathematical subject, with concepts that are difficult to understand and that have very few practical applications. Rao¹ has argued that two main reasons that electromagnetics is considered difficult by students is because it is abstract and involves visualization.

Attempts to make electromagnetics less abstract have ranged from introduction of practical applications in introductory electromagnetics textbooks to use of specialized simulation packages and web modules in instruction. For example, Krauss² has introduced many applications in the later editions of his book, Ulaby³ introduced application pages in the 5th edition of his book, and Demarest⁴ integrated electromagnetic theory with applied electrical engineering. Examples other than textbooks include making the content real, relevant, and usable in subsequent courses⁵, developing of specialized simulation packages as supplementary tools to teaching⁶ and development of virtual laboratories⁷, to name a few. Education research shows that lack of

integration of applications of electromagnetic theory is not an outlier in an otherwise cohesive curriculum. L. Dee Fink⁸ in his book "Creating Significant Learning Experiences, An Integrated Approach to Design College Courses", claims that the students see their college experience as the sequence of unrelated courses that lead to a degree.

In the past 20 years, the availability of simulators, multimedia, internet and personal computers are showing potential to make visualization of electromagnetic waves simpler for students. Efforts in this area can be generally divided in four categories: development of web-based or PC-based modules^{1,7,9,10}, introduction of visualization features in textbooks^{3,11,12}, commercial software used in the laboratories¹³, and introduction of numerical methods¹⁴. Hoburg¹⁵ has reasoned that students who develop visualization modules learn the underlying concepts well, whereas the students who are passively using modules do not gain the same level of understanding. It is therefore important to give students tools to generate simulations themselves. Gupta¹⁶ suggested the following examples of integration of the commercial simulators in education: illustration of basic concepts by iterative computations, design verification, what-if explorations, effect of real life parameters on design, realistic design example, virtual experiments, visualization of currents and fields. Examples of such exercises are given later in this paper.

On another front, education researchers have made significant progress in the past decade to understand how people learn¹⁷. Donovan and Bransford¹⁸ created a framework for teaching and learning grounded in four principles, or lenses: the learner-centered, knowledge-centered, assessment-centered and community-centered. Anderson and Krathwohl¹⁹, revised Bloom's taxonomy²⁰ by adding second dimension to describe the knowledge as factual, conceptual, procedural and metacognitive. In order to foster higher-level taxonomy objectives, students need time to think about the relationships between concepts taught²¹. The most remarkable development in this area that integrates new education research with visualization and technology is the complete overhaul of introductory physics class at MIT²². The novel approach in this paper is that the students write code and directly interact with commercially available software by setting up and solving various assigned problems, instead of using pre-built modules.

At CSUS, electromagnetics is a one semester, 4-unit course that students take during their junior year. It consists of a 3-unit class and 1-unit lab. Class is offered in a hybrid format, with lectures held both in the classroom and online through Blackboard's ElluminateLive! software so that students can attend classes remotely. Lectures are also recorded for asynchronous access to class. The class is currently taught with transmission-lines theory first, and the textbook is Applied Electromagnetics by Ulaby³ et. al. Typical student at the beginning of this class does not have any Matlab experience, has some understanding of vectors, very basic programming knowledge and algorithms, some basic understanding of fundamental electromagnetic from a physics class and some experience in linear algebra.

During the course of the semester, students write their own Matlab codes to visualize static electric and magnetic fields, potential distributions and equipotential surfaces due to various line, surface, volume charge and current distributions using Green's function integrals²³. Wave propagation is introduced through Matlab-based Graphical User Interface (GUI) designed for this purpose. Subsequently students write their own code to visualize animated forward, reflected and total voltages and currents on a transmission line. To demonstrate use of electromagnetics as a

fundamental discipline of electrical engineering PCB design and fabrication is introduced. Agilent's ADS is used to design microstrip lines, lumped element and transmission line impedance matching circuits. Agilent's 3D planar Method-of-Moments software Momentum is used to verify analytical design and matching of a microstrip patch antenna that is subsequently fabricated and measured. The class developed at CSUS is an attempt in improving student cognitive and affective domains by allowing them sufficient time to apply concepts taught in the lecture to produce creative, practical engineering results.

This article is organized as follows. In Visualization of fields and waves section, use of Matlab to visualize electrostatic and magnetostatic fields and potentials, and voltage and current propagation on a transmission line is presented. In the section Impedance matching and applications use of Agilent's ADS and Momentum to teach and learn impedance matching and antenna design is presented. In each section details of pedagogical and instructional approach, challenges and ways to overcome them are discussed. All Matlab codes, ADS and Momentum files and laboratories can be downloaded from author's web site²⁴. In the last section analysis of the effectiveness of student learning before and after using the industry level CAD tools is presented.

Visualization of fields and waves

Visualization of static electric and magnetic fields presents significant challenge for students because integration of vector calculus, electromagnetic theory and computer programming require meta-cognitive skills. In the recent past, several instructors reported active use of Matlab, Mathematica and Maple in electromagnetics classroom lectures. Belu³ et. al. have developed 12 electronic textbook modules using Maple and/or Matlab to support lectures and problem-solving activities. Zhao²⁵ has developed computer assisted materials to generate plots of electromagnetic fields in Matlab and Mathematica.

In this section, learner-centered instruction using Matlab is presented. The importance of integration of vector calculus, electromagnetic theory and computer programming is in relating various concepts to new, Matlab environment, where students learn how to creatively express themselves through active-learning exercises. This method gives students the ability to predict, estimate and visualize electromagnetics fields for typical cases of current and charge distributions. At the same time, it gives them more time in the laboratory to develop understanding of these complex concepts and make connections between concepts taught.

Visualization of Vector Fields and Potentials in Matlab

Visualization of individual vectors and one-dimensional functions is first introduced by using Matlab built-in functions **quiver** and **mesh**. Most students easily grasp how to graph a function of one variable $y = f(x)$, individual vectors and elementary operations with vectors. To plot array of vectors or a function of two variables built-in Matlab **meshgrid** function is used. This function presents an obstacle for students, and needs thorough introduction. Meshgrid is introduced by observing the 2D x-y plane first, as shown in Figure 1. Inputs to meshgrid function are two vectors that specify the range of x and y values where the function will be graphed. The coordinate pairs (x,y) are then split into two matrices, one that contains only x-values shown in Figure 2(a), and the other that contains y values shown in Figure 2(b). The position of the number in a matrix mirrors

the position of the point on the plane, as shown in Figure 2. Arithmetic operations with these matrices need further clarification. Addition and subtraction of matrices can be used to add meshgrid-made matrices x and y , because matrices are added or subtracted in an element by element fashion. In matrix multiplication or division, however, an element-by-element multiplication is defined as special dotted multiplication and division. Student's challenge is to distinguish matrix multiplication related to concise representation of system of equations and dotted matrix multiplication that represents element-by-element operation. Finally, the meshgrid in 3D is discussed, where meshgrid function generates an additional matrix to represent z -coordinates. For example, in x - y plane z -coordinate matrix consists of all zeros. Students follow a simple 8 point 3D meshgrid example to analyze x , y and z matrices.

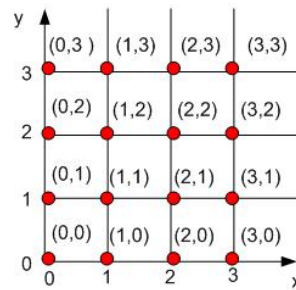

Figure 1: Coordinates of points in x-y plane.

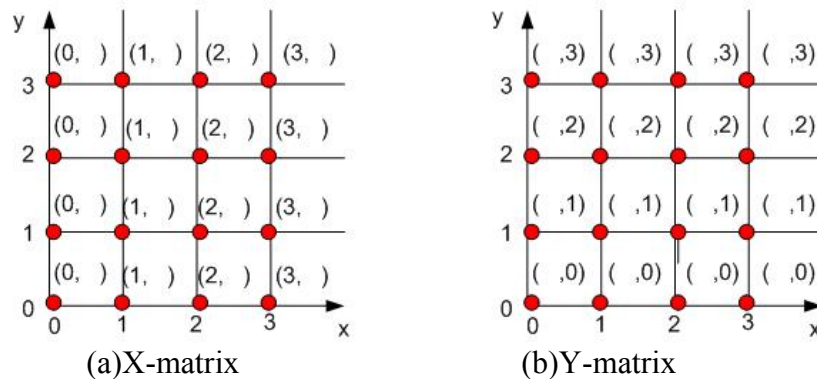

Figure 2: Separated coordinates of x-y points $0 \leq x \leq 3$ and $0 \leq y \leq 3$ range.

Once students understand meshgrid function, several examples of Matlab code to plot vector fields are reviewed. One visualization example is shown in Figure 3 for a vector field $\vec{A} = x\vec{a}_x + y\vec{a}_y$. Subsequently, students write code to plot assigned vector fields. Special instructions are given for vector fields that are only in x (or y) direction as quiver command requires both components to be matrices of the same size. First the dimension of the non-zero matrix is found using Matlab function **size**, and then a matrix of zeros for the y -components is generated.

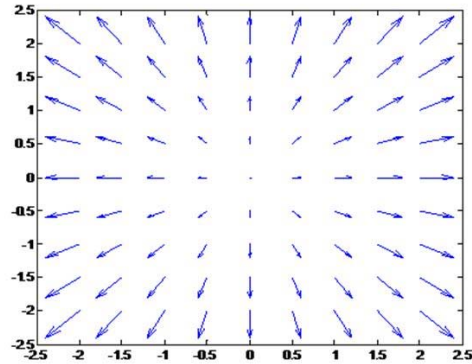
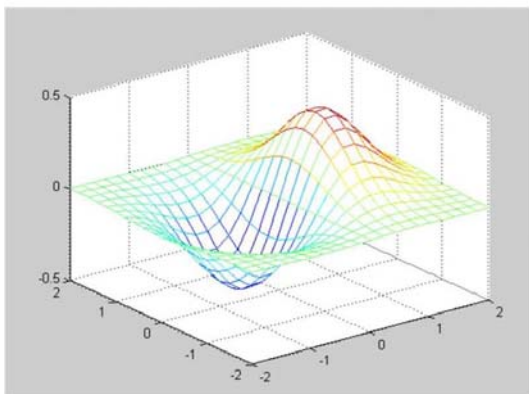

Figure 3: Position vector of point in Cartesian coordinate system.

Subsequently gradient, divergence and curl visualization is discussed. It is generally difficult for students to visualize vector operations, especially in 3D. Students are first introduced to gradient, divergence and curl with visualization examples, then they experiment with different functions and vector fields. Matlab functions that are introduced in this exercise are **divergence**, **gradient**, **curl**, **mesh**, **slice**, and **shade**.

Gradient is introduced first as a derivative of function of several variables. Gradient operates on a scalar function, generated by **mesh** command in Matlab, as shown in Figure 4(a) and the result of the gradient operation is a vector field 4(b). Gradient gives the maximum rate of change as shown in Figure 4(b), and the magnitude of vectors show the amount of change. Gradient in a certain direction is appropriately called directional derivative and is shown for x and y directions in Figures 4(c)-(d).



(a) Function Graph

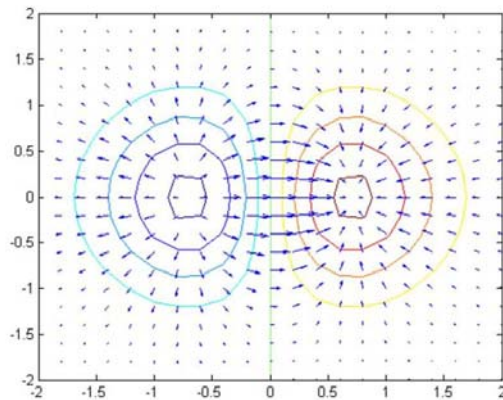

(b) Gradient and Countours of Function

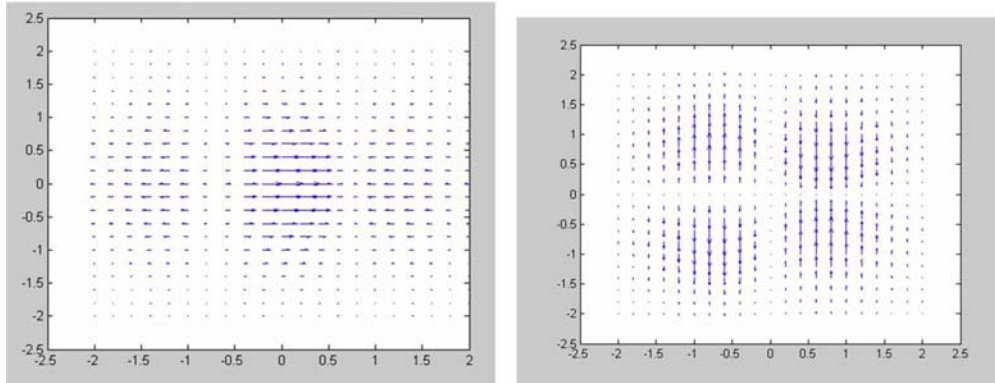

(c) Directional Derivative in \vec{a}_x direction (d) Directional Derivative in \vec{a}_y direction

Figure 4: Function $z = xe^{-x^2-y^2}$, it's gradient and directional derivatives

Divergence is a flux of a vector field through a closed surface. Divergence operates on a vector function Figure 5(a) and the result of the divergence operation is a scalar shown in Figure 5(b). 3D scalar field is visualized using Matlab **slice** function. Students look at the vector field going through a closed surface at a point and argue why the divergence looks as shown in Figure 5(b). Subsequently they design a field where divergence is high around coordinate origin and decreases as a function of distance from the origin.

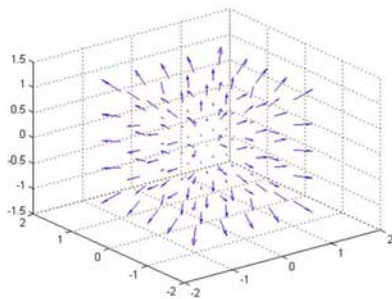

(a) Vector field

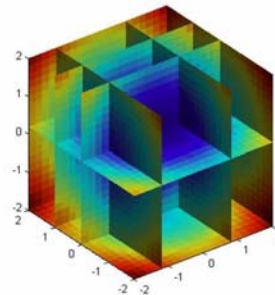

(b) Divergence (Flux) of Vector Field

Figure 5: Vector Field $\vec{A} = x^3\vec{a}_x + y^3\vec{a}_y + z^3\vec{a}_z$ and divergence of the field \vec{A} .

Curl describes rotation of the field and students first estimate the curl direction in Figure 6(a) by using the "paddle"^{4,26} in a vector field. The direction of the curl is perpendicular to the curling of the field and the magnitude describes the amount of rotation, as shown in Figure 6(b). Curl operates on a vector function and the result of the curl operation is a vector. Students then design a vector field so that the magnitude of curl changes throughout the volume.

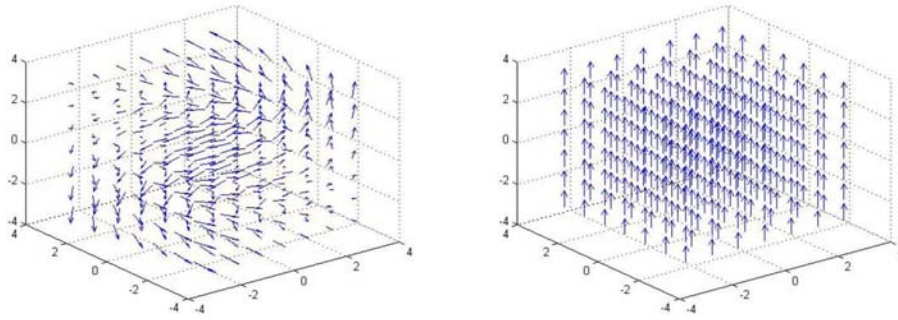

(a) Vector Field

(b) Curl of the field.

Figure 6: Vector Field $\vec{a} = -y\vec{a}_x + x\vec{a}_y + z\vec{a}_z$ and its curl.

When students are able to write codes in Matlab to visualize pre-defined vector fields, derivation of electromagnetic field using position vectors is discussed. Electric field at a point (x, y, z) due to a unit charge Q at a point (x_o, y_o, z_o) is given in Equation 1. Students derive this equation, explain the field qualitatively, then identify the components of the field in the x, y and z direction, and finally write a code in Matlab to plot it, Figure 7.

$$\vec{E} = \frac{Q}{4\pi\epsilon_0} \frac{(x-x_o)\vec{x} + (y-y_o)\vec{y} + (z-z_o)\vec{z}}{((x-x_o)^2 + (y-y_o)^2 + (z-z_o)^2)^{\frac{3}{2}}} \quad (1)$$

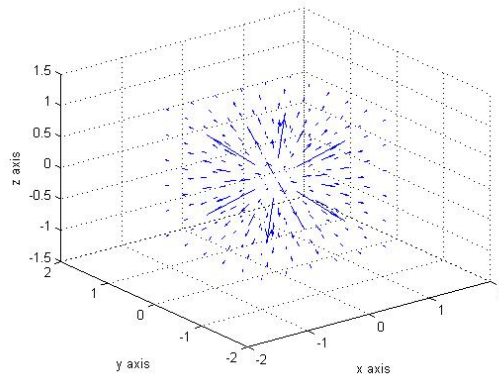

Figure 7: Electric Field of a unit charge.

To visualize Electric Field due to a loop of charge, use of position vectors in a systematic manner is discussed^{4,23,27}. Students find the total electric field of a charge distribution, assuming that each small piece of charge ΔQ contributes infinitesimal amount $\Delta\vec{E}$ to the total electric field, as shown mathematically in Equation 2.

$$\Delta\vec{E} = \frac{\Delta Q}{4\pi\epsilon_0 r^2} \hat{r} \quad (2)$$

The total electric field at a point P is then equal to the sum of all infinitesimal electric fields due to

the point charges as shown mathematically in Equation 3 and visually in Figure 8. Each component of the field is identified and summed separately, as shown in Equations 4-6.

$$\vec{E} = \sum_{\text{all point charges}} \Delta \vec{E} \quad (3)$$

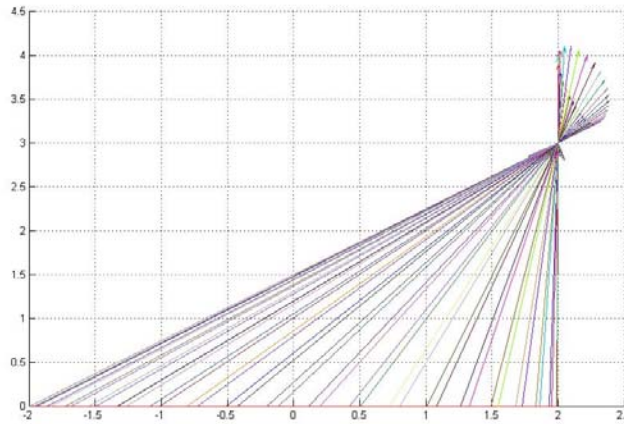

Figure 8: Loop of wire uniformly charged with line charge density ρ_l lays in x-y plane. Electric field is shown in x-z plane due to many small sections of the loop dl .

$$\vec{E}_x = \sum_{i=0}^n \frac{\rho_l a (x-a \cos\theta_i)\Delta\theta}{4\pi\epsilon_0\sqrt{(x-a \cos\theta_i)^2+(y-a \sin\theta_i)^2+z^2}^3} \vec{a}_x \quad (4)$$

$$\vec{E}_y = \sum_{i=0}^n \frac{\rho_l a (y-a \sin\theta_i)\Delta\theta}{4\pi\epsilon_0\sqrt{(x-a \cos\theta_i)^2+(y-a \sin\theta_i)^2+z^2}^3} \vec{a}_y \quad (5)$$

$$\vec{E}_z = \sum_{i=0}^n \frac{\rho_l a z\Delta\theta}{4\pi\epsilon_0\sqrt{(x-a \cos\theta_i)^2+(y-a \sin\theta_i)^2+z^2}^3} \vec{a}_z \quad (6)$$

In the limit the sums in Equations 4-6 become elliptical integrals that cannot be solved analytically, except in some special cases. Matlab plots for the electric field of a ring of charge is shown in Figure 9(a). To compare and contrast static electric field due to a charge distribution, and magnetic field due to a current loop I, static magnetic field is derived in a similar manner from Bio-Savart's law, and the result is shown in Figure 9(b). A student assignment is to repeat this procedure for a short filament of charge or current.

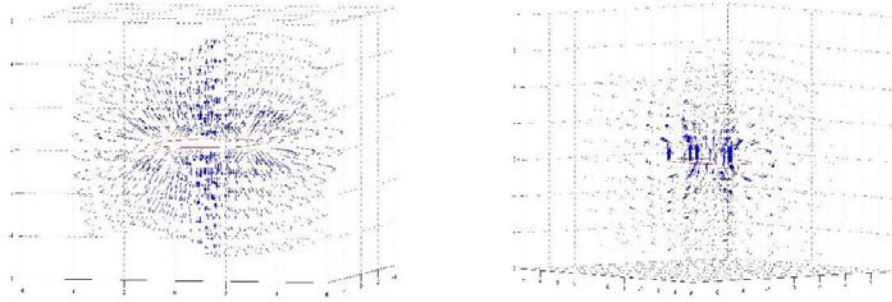

(a) Electric Field due to a ring of charge. (b) Magnetic Field due to a current loop

Figure 9: Compare and contrast between static electric and static magnetic fields of a loop of charge and loop of current.

Next, students develop equations for the potential due to a loop of charge using the same method as before, and plot it using Matlab's functions **shade**, **isonormals**, **countourslice** and **isosurface**. In a procedure equivalent to previously described one, potential of a loop of charge at a point P(x,y,z) shown in Equation 7 and graphed in Figure 10(b).

$$V = \sum_{i=0}^n \frac{\rho_l a \Delta\theta}{4\pi\epsilon_0 \sqrt{(x-a \cos\theta_i)^2 + (y-a \sin\theta_i)^2 + z^2}} \quad (7)$$

To visualize potential Matlab function **countourslice** is used, as shown in Figure 10(b). For equipotential lines, Matlab's function **isonormals** is used, and for equipotential surfaces, **isosurface** was used. Students discuss the shape of the equipotential surface shown and guess the shape of the surface far away from the ring. Finally students modify the Matlab code to graph the negative gradient of potential on the same figure and argue about the electric field direction on the surface.

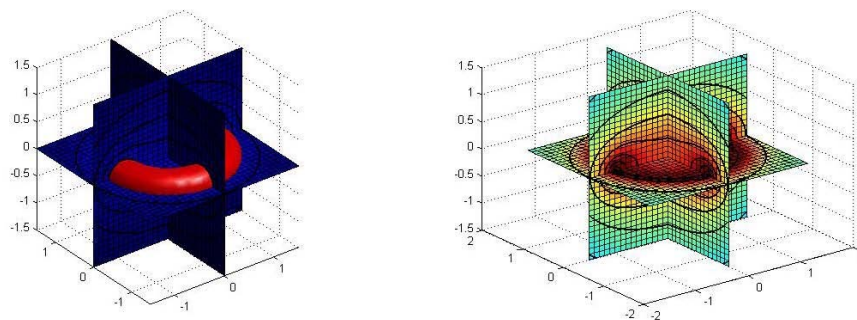

(a) Equipotential surface

(b) Potential Contours due to a ring of charge

Figure 10: Visualization of equipotential surfaces, equipotential lines and visualization of potential around a loop of charge.

Wave Animation

The voltage and current propagation on a transmission line is a difficult topic for students because the waves are a function of space and time. In addition, an array of new concepts such as reflection, transmission line impedance, standing waves, impedance matching and Smith Chart present challenging cognitive load. Several wave animation software modules have been developed over years to help students visualize wave motion. For example, FDTD²⁸ code was developed to show a Gaussian pulse motion and reflection. CAEME²⁹ center developed modules showing animated graphics of traveling and standing waves, and subsequently GUI enhanced module was developed⁷. Wentworth³⁰ suggests that Matlab or Mathcad examples can be successfully used in introductory electromagnetics courses to stir away students from finding an equation to produce the correct answer using a calculator, and towards understanding of the underlying concepts.

In this class, students first observe forward and reflected current and voltage on a transmission line using a GUI-enhanced Matlab code developed for this purpose. GUI code is user-friendly and allows students to specify the following parameters as shown in Figure 11(a): frequency of the generator, magnitude and angle of the load's reflection coefficient, transmission-line loss, line length, transmission line impedance, generator impedance and generator voltage. When all input variables are assigned Make button starts Matlab calculations of animated voltages and currents. Students can then select to display only forward waves, reflected waves, all voltage or all current waves. Display results window shows on the horizontal axis the spatial coordinate z from the generator at -1 to the load position at 0. On the vertical axis voltage in Volts and current in Amps is displayed. In Figure 11(b), an example case shows incident, reflected and total voltage and the magnitude of the total voltage on the line.

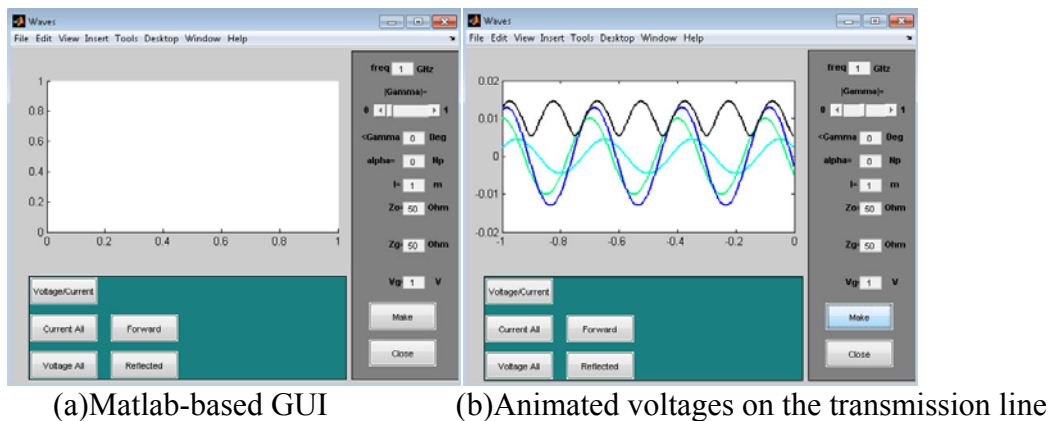

Figure 11: Developed Matlab-based GUI for visualization of voltages and currents on a transmission line.

After observation of waves in GUI, students write their own Matlab code to animate voltage and current signals on a transmission line, using code from Matlab's GUI described before for guidance. First students plot on the same graph voltage as a function of position on a transmission line at four different time instants, for forward and reflected wave, to make a connection between the mathematical equations and their physical representation. In the end, students use Matlab functions **getframe** and **movie** to make forward and reflected voltage animations on the

transmission line.

Impedance Matching and Applications

When students are given autonomy by early exposure CAD tools, they become active, independent and life-long learners. Coupez³² et. al. have achieved good results by using freely distributed software Puff developed at Caltech in motivation and training of students in microwave and RF classes. Some specialized modules have been developed as well, such as Smith Chart Modules^{7,31}. Badii³³ et. al. designed a Smith Chart module using Matlab to calculate impedance matching networks analytically and display the results graphically on the Smith Chart.

In this class basic RF concepts and characterization of microwave circuits are introduced. ADS is first used to illustrate reflection coefficient calculation and position on the Smith Chart. For pedagogical reasons combination of Z and Y charts superimposed on the same diagram is used. ADS displays Smith Chart in this fashion, and students find consistent methodology from lecture to laboratory and homework exercises. Reflection coefficient is illustrated in ADS by simulation of a simple two-port circuit. One port simulates the load, with the real and imaginary part of the impedance specified, and the other port simulates the measurement instrument, and is therefore set to 50 Ohms, as shown in Figure 12. Students vary the load port impedance with a fork utility in ADS and observe changes of the reflection coefficient on the Smith Chart using a marker utility.

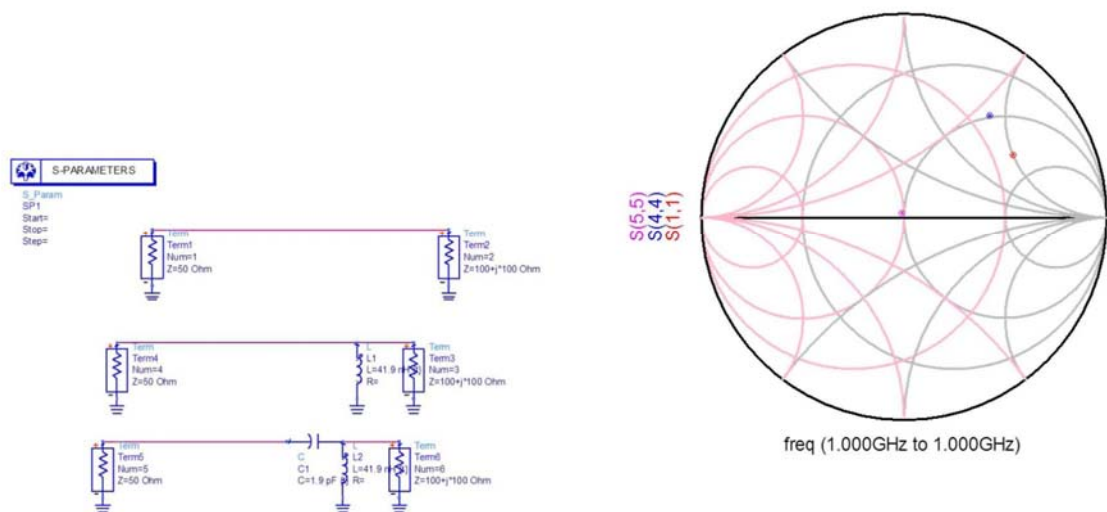

(a) Three step circuit setup in ADS for lumped element impedance matching

(b) Smith Chart that results from the simulation shown in (a)

Figure 12: Lumped element What-if impedance matching game

Next, students develop lumped element impedance matching circuit in three steps as shown in Figure 12. In the first step they start from two S-parameter ports as described before to get the position of the load port impedance on the Smith Chart. In the following step they add another set of terminations, leaving the first two intact, so that the original point stays on the Smith Chart. In this step, students modify the circuits between the second set of ports. They play a what-if game by

adding a capacitor or an inductor to the load impedance in parallel and series, and observe how the reflection coefficient point moves on the constant Y or Z circles of the Smith Chart. Using Fork function in ADS they further change the capacitance or inductance values incrementally and observe the effect on the Smith Chart. Additional capacitance moves the reflection coefficient point downwards to more capacitive parts of Smith Chart, and additional inductance moves the point towards the more inductive part of the Smith Chart (up). Subsequently, students are instructed to move the reflection coefficient point on $Z=1$ or $Y=1$ circle, and then to the center of the Smith Chart. This simple visualization game helps students understand lumped element impedance matching.

As an introduction to transmission-line matching, finding input impedance of the transmission line and SWR circle using ADS are taught, followed by the special cases of open and short circuited stubs. Then, impedance matching using ideal transmission lines is taught by following a similar sequence of three step set up, as shown in Figure 13. After these exercises, students easily recognize different configurations of impedance matching networks and make lumped element, transmission line matching circuits or a combination with ease.

Initially, ideal transmission lines are used, and they are subsequently replaced by microstrip transmission lines to investigate how real-life parameters affect the circuit design, as well as design restrictions for specific application or implementation of impedance matching network. At the end of this sequence students undertake a patch antenna project, where they design, simulate, fabricate and measure a square- patch antenna.

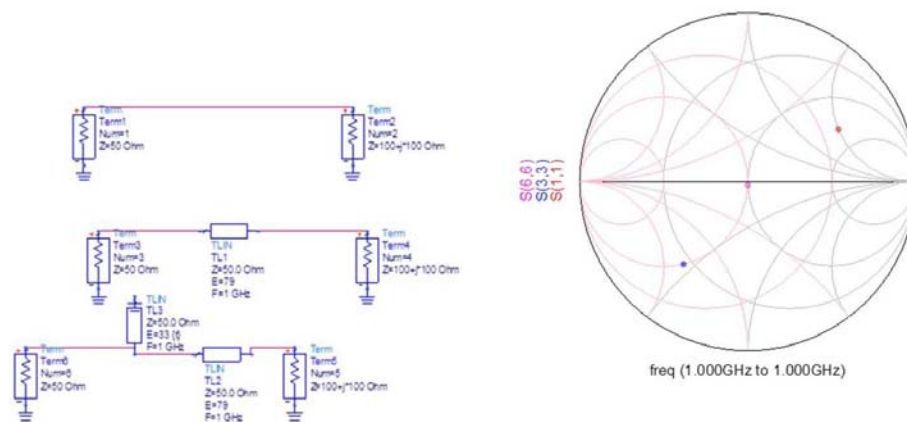

(a) Three step circuit setup in ADS for lumped element impedance matching

(b) Smith Chart that results from the simulation shown in (a)

Figure 13: Transmission-line What-if impedance matching game

Application of Impedance Matching using Momentum

Gupta¹⁵ has argued that the one of the major impacts of CAD in education is in making realistic design examples and case studies available to students. In this class, 3D planar electromagnetic simulator Agilent's Momentum is introduced to simulate a square-patch antenna.

Full-wave 3D or planar simulators such as Ansys HFSS, Sonnet's CST, Mentor Graphic's HyperLynx 3D EM, Agilent's Momentum are powerful simulation tools that are rarely used in undergraduate curriculum because of the prohibitively long time to learn them effectively. Gupta³³ suggested that students may not be able to recognize that the solution given by the simulator is inaccurate. However, use of full-wave simulators is very important to keep the students interested in the content as suggested by Gupta³⁴, and some attempts have been made to fully integrate them in undergraduate Electromagnetics education¹³. The introduction of Agilent's Momentum simulator achieves several teaching objectives. First students are able to see the displayed animated waves that propagate down the transmission line and into the antenna, and the standing wave on the resonant structure. This visualization exercise would be too complex for student to produce themselves on a paper or programming from scratch by using Matlab or Mathematica. Second, introduction to CAD used in industry engages students because students' perceive it as very valuable to their career. To bridge the prohibitively long time to learn the software use and students' desire to use the software on the other side, guided software use is introduced as a laboratory project. Momentum is a 3D planar method of moments software that is distributed as part of ADS. Two working patch antenna simulator files are given to students, and they change some simulation parameters such as dielectric thickness and ϵ_r , height of the substrate, and the size of the patch antenna.

The objective of the lab is to design, match, fabricate and measure square patch antenna at 1 GHz. As an introduction to patch antenna project, students have several laboratory periods where they are introduced to substrates and microstrip lines, PCB circuit prototyping using TTEch milling machine and have a practical laboratory exercise where they learn how to use Network Analyzers and measure antenna pattern. In preparation for the project, students select substrates that are available in the laboratory, and choose the frequency of operation f_r around 1 GHz. Students then find the dimensions of a square patch³⁶ shown in Equation 8.

$$L = 0.49 \frac{\lambda}{\sqrt{\epsilon_r}} \quad (8)$$

Where λ is the wavelength in free space at the frequency of operation f , and ϵ_r is the relative dielectric constant of the substrate. The input impedance of the resonant-edge fed patch³⁶ is shown in Equation 9.

$$Z_{in} = 90 \frac{\epsilon_r^2}{\epsilon_r - 1} \left(\frac{L}{W} \right)^2 \Omega \quad (9)$$

Once students have the preliminary design calculated by equations above, they download prepared example file for Momentum simulation and change the dimensions of patch antenna and parameters of their substrate. Then they simulate S-parameters, and compare the input impedance at the frequency of operation with the impedance found in Equation 9 as shown in Figure 14(a).

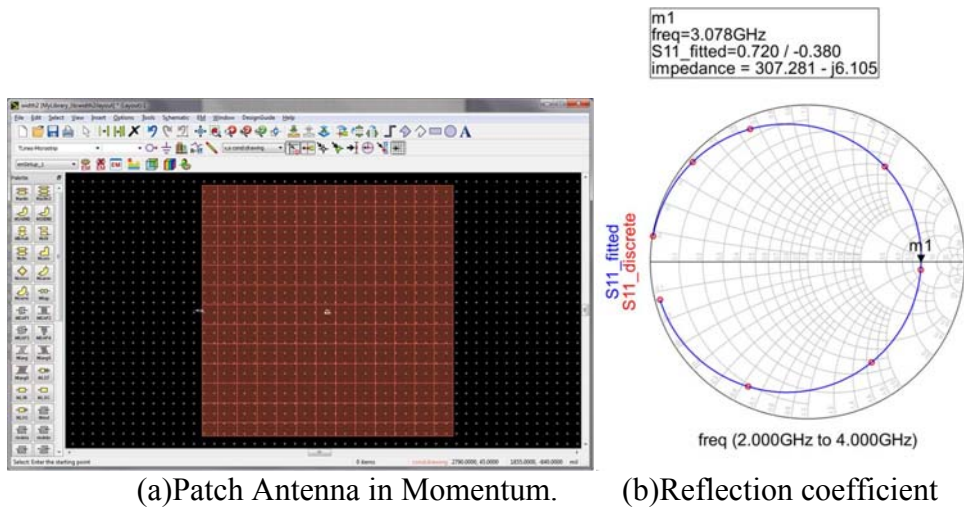
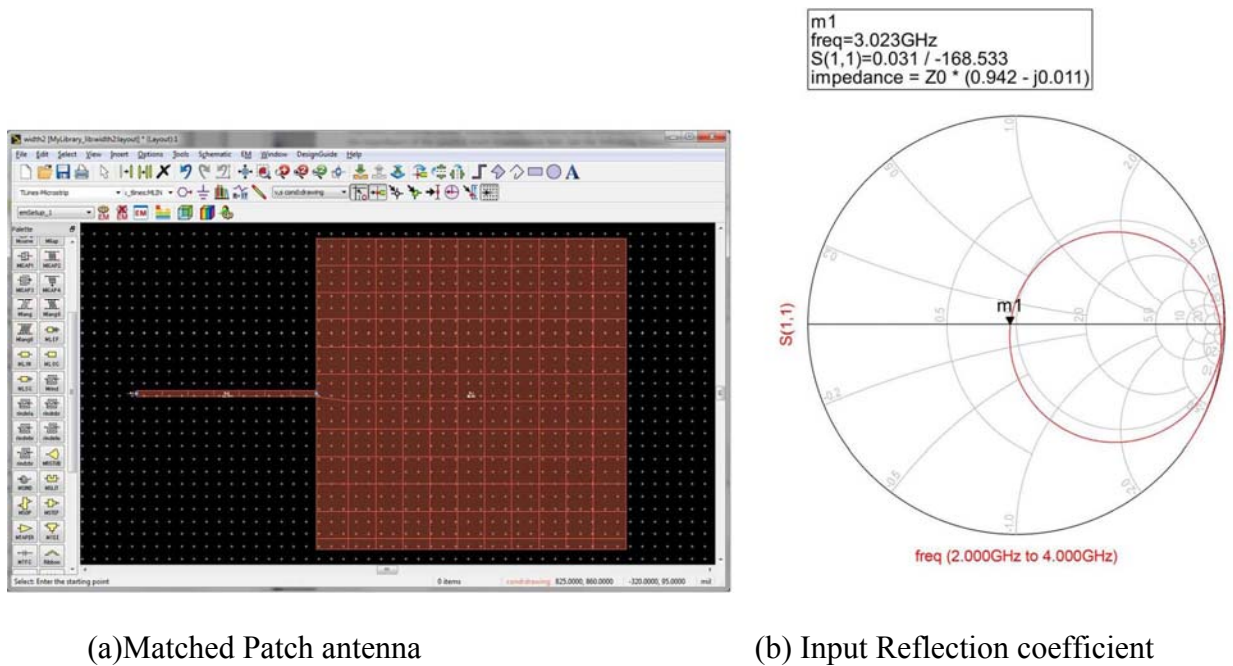
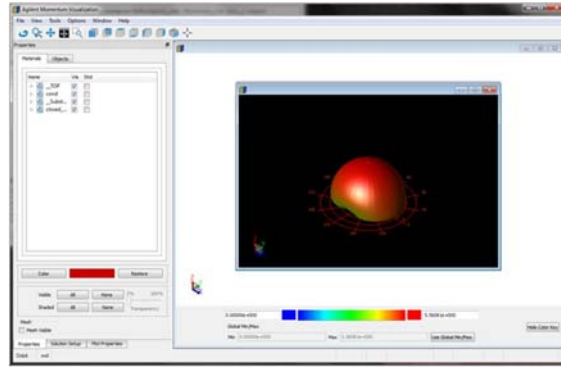

Figure 14: Patch antenna simulation in momentum.

Since the input impedance of student's patch is not 50-Ohms, they design an impedance matching circuit using microstrip lines. Students use LineCalc feature in ADS to find the length and width of the actual transmission line on the chosen substrate. Then they use Momentum again to evaluate the design performance as shown in Figure 15 and observe wave propagation and standing waves on the patch antenna for different frequencies. Finally, students investigate if the design is manufacturable and how artwork affects the design.





(b) Far-field radiation pattern

Figure 15: Matched patch antenna simulation in momentum.

Assessment of student learning

In this section the assessment of use of CAD software to students' cognitive and affective domains is analyzed. Assessment consists of direct and indirect measures of student learning and engagement. Direct measure of student learning is based on summative in-class test results. Comparison of test results before and after the laboratory was introduced is analyzed. Indirect measures are based in three surveys: In-house faculty evaluation of student performance, Class Level Assessment of Student Engagement (CLASEE) and student evaluation of faculty effectiveness SIR II. CASSE and SIR II surveys were distributed in 2011 and 2012, whereas the in-house faculty evaluation of student performance survey was distributed in Spring 2007. The assessment cycle started in 2005 by analysis of students' performance in focused group meetings.

To respond to ABET accreditation "closing the loop" requirements, EEE department faculty conducted electronics area faculty focused group meetings in 2005-2006 to identify various ways to improve the curriculum. One of the results of these focus groups was to change the format of Electromagnetics class from 4-unit lecture to 3 unit lecture and 1 unit lab. The intention was to increase student-faculty time, to improve students' ability to visualize electromagnetic fields and for students to see further practical application of electromagnetics. The Matlab visualization exercises have already been developed and assigned to students as homework assignments, but students couldn't learn CAD software on their own, and needed additional supervised time. In Fall 2007 the first laboratory was offered, with material consisting mostly of solution of homework exercises using Matlab and review of class material.

After the focused groups meetings, in-house developed survey was distributed to electrical engineering faculty in Spring 2007. Survey asked faculty two questions, how important specific topic is within a class and how well students understand it. The survey results were presented in a quadrant format as shown in Figure 16 and topics that are the most important, but least well understood by the students are identified: transmission lines, electrostatics and vector analysis.

Faculty Survey EEE161

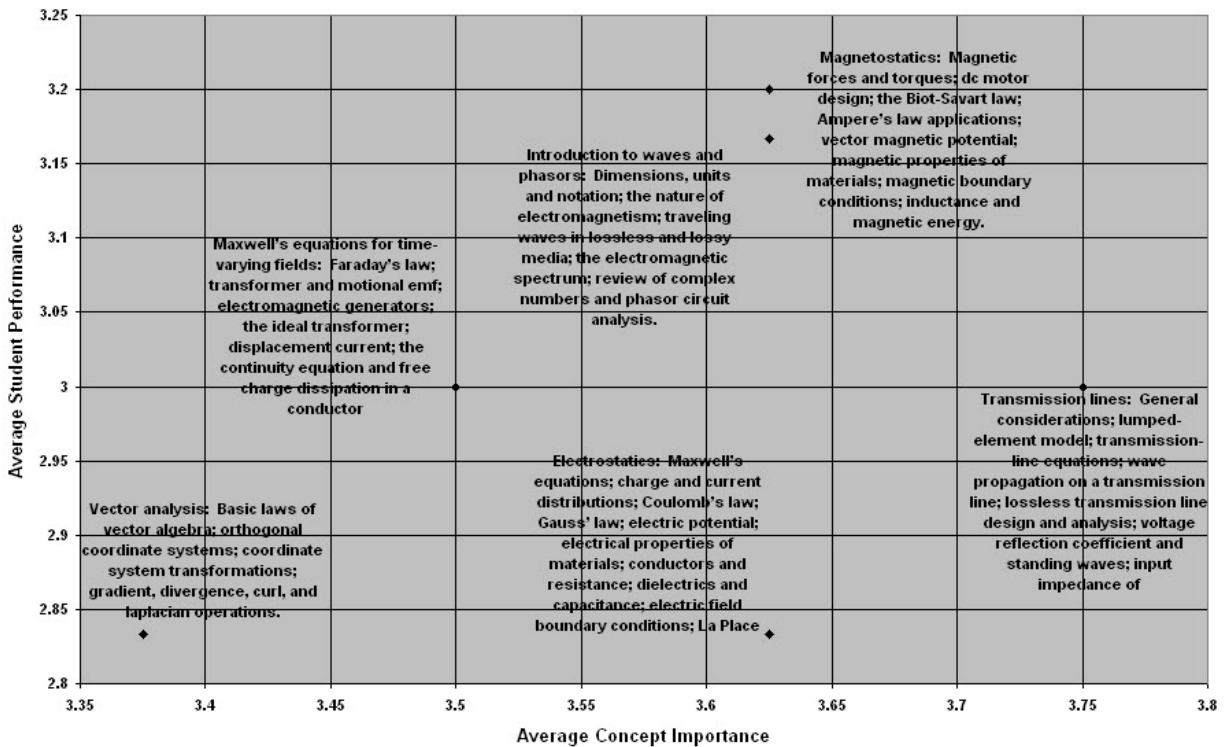

Figure 16: Results of Faculty Survey Spring 2007.

Student performance in class distributed midterm examinations have been compared in Spring 2007 and Spring 2011 to Spring 2012. Since all exams distributed were different, an attempt was made to evaluate problems from both student and faculty perspective. The level of exam challenge was analyzed through the exam score distribution, and instructor's evaluation of test challenge. Exam score distribution is divided into the brackets with boundaries of 40%, 60%, and 80%. The second instrument was faculty evaluation of how difficult each problem on the exam is on the scale from 1 to 5. The following attributes were given to numbers 1-5: (1) very easy problem, possibly seen in pre-requisites, requires little work, (2) Concept seen in pre-requisites, but requires more work, (3) new concept, similar problem on hw or lecture, (4) new, difficult or math intensive concept seen in some form, (5) very difficult problem, new application. In Spring 2007 five in-class examinations were distributed, each targeting specific course learning outcome within an area described in the official course description. The percentage of a students who scored on a problem 60% or above was calculated. The following concepts had the lowest satisfactory performance percentage: Derivation of magnetic field for a current distribution (29%), phasors (32%), calculating forward and reflected wave on transmission line (32%), see Figure 17. These results confirmed the survey conducted by faculty, and added phasors on the list of concepts to be monitored. Magnetic field for a current distribution concept depends on understanding of vector algebra and calculus, and transmission line problem is heavily dependent on understanding of phasors. Deriving magnetic field of a charge distribution is potentially lower because it involves vector product and integrals, an additional level of complexity. To improve knowledge of these

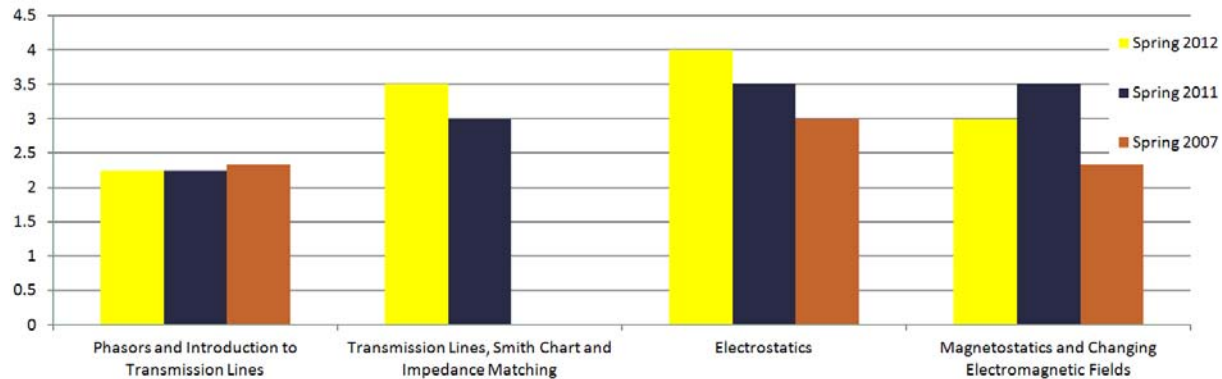

Figure 18 Instructor Rated Test Difficulty. The lower the number the easier the test.

Classroom Survey of Student Engagement (CLASSE) is a 40 question survey developed by Julie Ouimet and Bob Smallwood as an adaptation of NSSE, National Survey of Student Engagement. CLASSE is an equivalent survey to National Survey of Student Engagement (NSSE), but it is distributed at the classroom level to measure how often students engage in certain classroom activities. This information is then compared with the instructors' rating of how important different activities are. Survey consists of 49 questions. In Spring 2012 35 out of 40 students have taken the survey. As shown in Figure 19, 67% of students responded that they very often engage in applying theories or concepts to new and practical problems or in new situations, and 70% of students stated that they very often or often worked harder than they thought they could to meet instructor's expectations. This is an important result showing that students do engage in activities that allow them to relate electromagnetics to engineering. The other questions show that students often engaged in higher-level Bloom's taxonomy activities, which were scored high on instructor's importance scale. One of the challenges electromagnetic instructors face is to decrease the amount of challenge. In order for students to be engaged there needs to be an optimal amount of challenge so that the students don't get discouraged and give up.

Student Instructional Effectiveness Report (SIR II) is a survey developed by Educational Testing Service Company for student evaluation of faculty teaching effectiveness. The survey consists of 45 questions. Students answer questions on the scale from 1 to 5. 12 questions shown in Figure 20 have been monitored in class and laboratory from Spring 2011 to Spring 2012. The scale for the questions 8, 9, 21, 24, 25, 28 was: ineffective (1); somewhat effective (2); moderately effective (3); effective (4); and very effective (5). The scale for the other questions in Figure 20 was: much less than most courses (1); less than most courses (2); about the same as others (3); more than most courses (4); much more than most courses (5). The percentages of students answering each question with 3, 4, and 5, have been added in Figure 20. The difference between this and previous survey is that the questions in this survey are formulated in such way that students are comparing electromagnetic class with other classes they have taken. The level of challenge and the workload percentages show that the students see electromagnetic as at least difficult as other classes or more difficult. In addition, the interest in the subject area has increased after this class, compared to other classes for about 70% of students. On average 80% of students compare use of computer aids in instruction as moderately effective or above. These results are encouraging and point to the necessity of incorporating CAD software further to engage students and relate electromagnetics to engineering practice.

*Proceedings of the 2013 American Society for Engineering Education Pacific Southwest Conference
Copyright © 2013, American Society for Engineering Education*

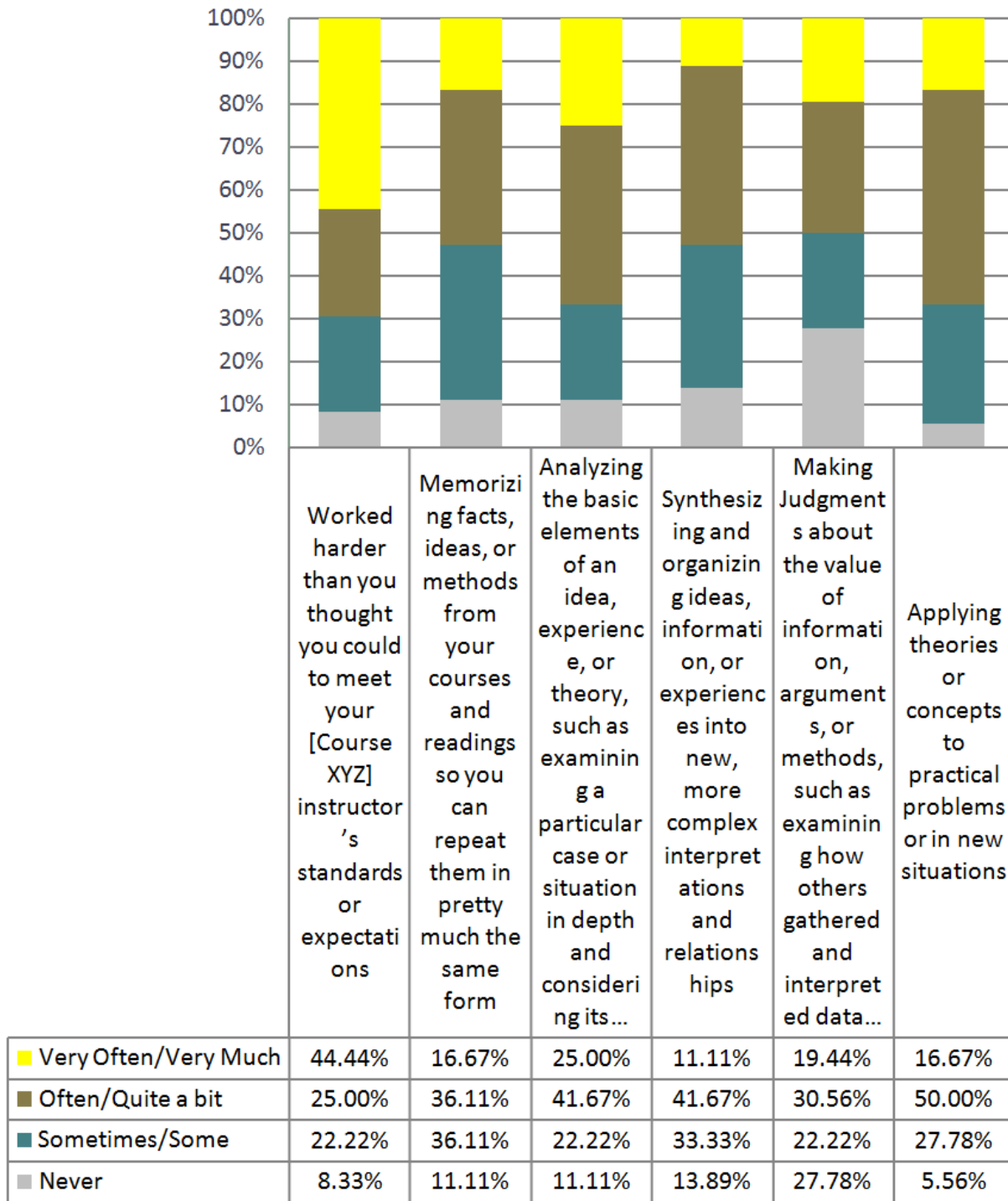

Figure 19: CLASEE Survey on Class Practices in Spring 2012.

	CLASS	Spring 2012	Fall 2011	Spring 2011	LAB	Spring 2012	Fall 2011	Spring 2011
8. The instructor's use of examples or illustrations to clarify course material		96%	94%	85%		72%	92%	88%
9. The instructor's use of challenging questions or problems		79%	100%	86%		79%	84%	87%
21. The helpfulness of assignments in understanding course material		80%	94%	79%		78%	92%	62%
24. Laboratory exercises for understanding important course concepts		60%	67%	79%		73%	81%	69%
25. Assigned projects in which students worked together		58%	89%	77%		81%	90%	77%
28. Instructor's use of computers as aids in instruction		85%	83%	79%		85%	80%	66%
31. My interest in the subject area has increased		60%	90%	76%		62%	92%	50%
32. This course helped me think independently about the subject matter		75%	79%	84%		65%	91%	62%
33. This course actively involved me in what I was learning		80%	94%	92%		67%	92%	71%
36. I was challenged by this course		95%	89%	99%		93%	85%	99%
37. For my preparation and ability, the level of difficulty of this course was:		100%	100%	100%		100%	101%	100%
38. The work load for this course in relation to other courses of equal credit was:		100%	100%	100%		100%	100%	100%

Figure 20: Assessing student attitudes using SIR II survey.

Conclusion

In this paper visualization of electromagnetic fields and waves, and applications of practical engineering in an introductory electromagnetic class is presented. The class is designed to help students visualize theoretical concepts taught and set electromagnetic theory in a context of real engineering applications. Students are engaged through use of industry standard CAD tools in an active-learning environment. Assessment results are show that inclusion of CAD tools engages students and helps them relate electromagnetics to engineering practice.

References

1. Rao, N. N. PC-assisted instruction of introductory electromagnetics. *Education, IEEE Transactions on*, 33(1):51-59, 1990.
2. Kraus, J.D. *Electromagnetics*, volume 45. McGraw-Hill, 1999.
3. Ulaby, F. and Michielssen, E. and Ravaioli, U. *Fundamentals of applied electromagnetics*. Prentice Hall, 6th edition, 2010.
4. Demarest, K.R. *Engineering electromagnetics*. Prentice Hall, 1998.
5. Mandayam, S.A. and Krchnavek, R. R. Real Electromagnetics for Real Engineers - Really!. 2001
6. Leung, Wing-Kai and Chen, Yinchao and Lee, Yim-Shu. EM wave simulation: An animated electromagnetic wave teaching package. *Computer Applications in Engineering Education*, 9(4):208-219, 2001.
7. Iskander, M. F. Technology-based electromagnetic education. *Microwave Theory and Techniques, IEEE Transactions on*, 50(3):1015-1020, 2002.
8. Fink, L. D. *Creating significant learning experiences: An integrated approach to designing college courses*. Jossey-Bass Inc Pub, 2003.
9. Belu, R. and Belu, A. Using Symbolic Computation, Visualization, And Computer Simulation Tools To Enhance Teaching And Learning Of Engineering Electromagnetics. *ASEE 2009 Annual Conference & Exposition*, 2009.
10. Human, I. and Sinigoj, A. R. and Hagler, M. O. Mathematical tools for supporting Web-based education of *Proceedings of the 2013 American Society for Engineering Education Pacific Southwest Conference*
Copyright © 2013, American Society for Engineering Education

- electromagnetics. *Information Technology Based Higher Education and Training, 2004. ITHET 2004. Proceedings of the Fifth International Conference on*, pages 111-116.
11. Wentworth, S.M. *Fundamentals of electromagnetics with engineering applications*. Wiley, 2004.
 12. Lonngren, K.E. and Savov, S.V. and Jost, R.J. *Fundamentals of Electromagnetics with MATLAB*. SciTech Publishing, 2007.
 13. Mills, A. K. and Chappell, W. J. On the use of commercial FEM electromagnetic software in an undergraduate curriculum. *Antennas and Propagation Society International Symposium, 2004. IEEE*, pages 3365-3368 Vol.3.
 14. Obiozor, C. N. and Sadiku, M. N. O. Finite elements in electromagnetics for undergraduate curriculum. *Southeastcon '93, Proceedings., IEEE*, pages 4 p.
 15. Hoburg, J. F. Can computers really help students understand electromagnetics?. *Education, IEEE Transactions on*, 36(1):119-122, 1993.
 16. Gupta, K. C. Role of microwave simulators in education-present and future. *IEICE Transactions on Electronics*, E84-C(7):861-868, 2001. Japan.
 17. Bransford, J. *How people learn: Brain, mind, experience, and school*. National Academies Press, 2000.
 18. Donovan, S. and Bransford, J. *How Students Learn: History, Mathematics, and Science in the Classroom*. Natl Academy Pr, 2005.
 19. Anderson L. W., Krathwohl D. R. et al. (2001). A taxonomy for learning, teaching and assessing: A revision of Bloom's Taxonomy of educational outcomes: Complete edition, New York: Longman.
 20. Bloom, B.S. *Taxonomy of Educational Objectives: By a Committee of College and University Examiners*. Longmans, Green, 1954.
 21. Gunter, M. and Estes, T. and Schwab, J. *Instruction, a models approach*. Pearson Education, Inc., 4th edition, 2003.
 22. Dori, Y.J. and Belcher, J. How does technology-enabled active learning affect undergraduate students' understanding of electromagnetism concepts?. *The Journal of the Learning Sciences*, 14(2):243-279, 2005.
 23. Gilbert, J. Don. Green's Function Integrals in Undergraduate Electromagnetics. *Education, IEEE Transactions on*, E-30(4):252-254, 1987.
 24. Marković, M. EEE 161 Applied Electromagnetics Web Site. 2012. <http://gaia.ecs.csus.edu/milica/eee161.html>.
 25. Zhao, T. Introducing math software and electromagnetics simulation software to enhance the vector field understanding in EM classes. *ASEE 2007 Annual Conference & Exposition, 2007*.
 26. Iskander, M. F. *Electromagnetic Fields and Waves*. Waveland Press, Long Grove, 1992.
 27. Sadiku, M. *Elements of electromagnetics*. Oxford university press, 2001.
 28. Glisson, Allen W. and Elsherbeni, Atef Z. An interactive 1D Matlab FDTD code for education. *Computer Applications in Engineering Education*, 9(2):136-147, 2001.
 29. Iskander, M. F. Computer-based electromagnetic education. *Microwave Theory and Techniques, IEEE Transactions on*, 41(6):920-931, 1993.
 30. Wentworth, S. and Mousavinezhad, S. H. and Mina, M. and Pan, W. Enhancing Electromagnetics Instruction Using Matlab and Mathcad. *American Society for Engineering Education Annual Conference and Exposition*.
 31. Vidal, O. D. L. S. and Iskander, M. F. Multimedia modules for electromagnetics education. *Computer Applications in Engineering Education*, 5(4):257-267, 1997. Cited Reference Count: 9 5768392 Usa Wiley.
 32. Coupez, J. P. and Person, C. and Toutain, S. Electromagnetic theory, CAD and experimental approach: fundamental bases of an efficient education program in microwave and RF techniques. *Microwaves, Radar and Wireless Communications, 2002. MIKON-2002. 14th International Conference on*, pages 433-436 vol.2.
 33. Badii, Vahid and Oloomi, Hossein M. Transmission line application MATLAB Toolbox based on the graphical design methods of the Smith chart. *Computer Applications in Engineering Education*, 6(1):23-30, 1998.
 34. Gupta, K. C. and Itoh, T. and Oliner, A. A. Microwave and RF education-past, present, and future. *Microwave Theory and Techniques, IEEE Transactions on*, 50(3):1006-1014, 2002.
 35. Gupta, K. C. and Ramadoss, R. and Huantong, Zhang. Concept mapping and concept modules for Web-based and CD-ROM-based RF and microwave education. *Microwave Theory and Techniques, IEEE Transactions on*, 51(4):1306-1311, 2003.
 36. Stutzman, W.L. and Thiele, G.A. *Antenna theory and design*, volume 320. J. Wiley, 2nd edition, 1998.

Teaching Introductory Programming Concepts: A Comparison of Scratch and Arduino

Anne Beug, Phillip L. Nico
Department of Computer Science,
California Polytechnic State University, San Luis Obispo

Abstract

In this paper we present our experiences developing and delivering two separate introductory computer programming units for high school students—one based on the Scratch visual programming environment and the other based on the Arduino embedded system prototyping platform. Scratch is a well-proven educational software development platform that teaches core programming concepts through a graphical programming interface, aimed at junior high and high school-aged students. The Arduino platform consists of both hardware and software: an open source microcontroller system programmed in a C-like language. We developed parallel curricula in Scratch and Arduino and compared the two in the setting of five high school classrooms. Each course consisted of five sessions (with a lecture and a lab), each covering a different topic, building on previous sessions. While the results of our quantitative study have not been conclusive, our experience suggests that the Arduino platform is not yet ready for teaching core programming concepts to computing novices. The combination of the C-like language and the hardware were too complex for novice programmers to use in learning programming concepts.

Introduction

We performed a study to evaluate the suitability of the Arduino platform in teaching core computing concepts to high school students. We held series of five sessions with various classes at two local high schools—both programming classes and computer application (Word, Excel, etc.) classes. Students in the classes had diverse educational and computing backgrounds—some had no computing education and did not feel comfortable with computers and others had completed an AP Computer Science course in Java.

During each class session, we covered a core programming concept, with each session building on previous sessions. The first session introduced the students to computer programming, as well as either the Scratch or Arduino programming environment. During the remaining sessions, we introduced the concepts of variables, conditionals (if-else statements), iteration (loops) and functions. We wanted to see how well each environment would work for teaching each concept and programming in general.

We assessed the students' grasp of the chosen concepts and experiences through a pre-survey and a post-survey with quantitative and qualitative questions. Both surveys also asked the students about their computing background and attitudes toward computing.

Platform Choice

We chose Arduino as our experimental platform to study because of its growing popularity with electronics hobbyists^[14] and recent introduction into embedded systems curricula^{[11][14]}. We found a dearth of research on using Arduino to teach introductory programming education. The Arduino platform consists of a set of microcontrollers, a programming language and an IDE. All components of the platform are open source. The language is based on the Wiring and Processing^[1] languages that were created to teach core programming and computing concepts through electronics and visual arts respectively. Arduino as a language is syntactically similar to C and Java.

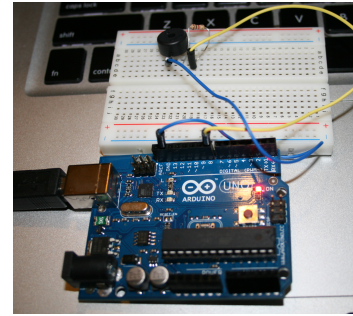

Figure 1: Arduino microcontroller

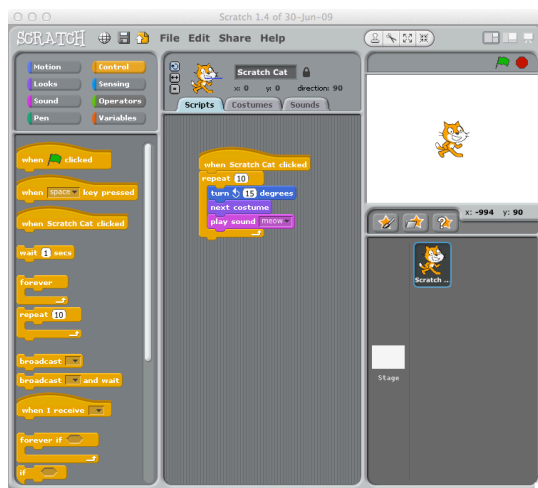

Figure 1: Scratch development environment

Scratch, on the other hand, grew out of academic work in MIT's Lifelong Kindergarten Lab, officially launching in 2007 as a new educational programming and computing platform. From its website, "Scratch is designed to help young people (ages 8 and up) develop 21st century learning skills. As they create Scratch projects, young people learn important mathematical and computational ideas, while also gaining a deeper understanding of the process of design. With Scratch, kids can create their own interactive stories, games, music, and animations...^[2]"

Scratch's visual programming interface allows users to build programs by selecting "blocks"

(programming instructions) from a palette on to a script area. The blocks click together only in meaningful ways, preventing syntactical errors.

Because Scratch does not have built in functions, we taught the last Scratch lab (functions) in BYOB 3.1 (Build Your Own Blocks). BYOB is an extension to Scratch that includes the ability to create custom blocks^[13].

Multiple studies have been performed investigating the effectiveness of Scratch in teaching introductory programming concepts^{[6][7][8][15][16][17]}. It works well for some concepts (loops and conditionals) but not for others (variables and functions)^[8]. Scratch has been accepted as a platform for teaching novice programmers in junior high^[5], high school and at the university level^{[7][8][15][16][17][18]}.

The other platform we considered for our control group was Alice^[19]. However, we chose to use Scratch as it is already used in many of our university outreach programs as well as in the local elementary and secondary school district. Using BYOB in the final lab alleviated our main concern with Scratch—that it does not have the capability to express functions.

Related Works

There is a diverse and large body of research in the area of computer science education, focused on primary, secondary and tertiary schools, starting in the 1970's^[3]. One common theme in many papers is the fact that learning and teaching programming is difficult^{[3][4][5]}. Other work studies the specific problems novice programmers encounter. Pea writes about different "conceptual bugs" in novice programming^[4] – misunderstanding the order in which programs execute, attributing intentionality to programs and assuming the programs can read the programmer's mind.

Studies have found various results using Scratch to teach core computing concepts. Colleen Lewis reports students learned conditional statements better through Scratch than Logo^[6], but, surprisingly, did not show greater comprehension of loops. In "Habits of Programming in Scratch," Meerbaum-Salant, et al.^[7] found that while Scratch encourages self-directed learning, students only really learned programming concepts when explicitly taught the concepts. Rivzi, et al.^[8] describe a new Scratch-based undergraduate course (CS0) inserted before the traditional first programming course (CS1) aimed to increase student retention. One set of students enrolled directly in CS1, while the others enrolled first in CS0. Amongst the CS0 set, the researchers found increased interest in computer science as well as improved learning outcomes. Another study investigated learning results of computer science concepts by students learning in the Scratch environment^[9]. A Scratch-based curriculum was developed for middle-school-aged children. Middle school teachers taught the course during regular school hours. Students performed well with loop concepts, but less so with variables.

Far less research has been performed with Arduino, perhaps because it was not conceived as an educational platform. Most work describes integrating Arduino in to existing microcontroller or robotics courses^{[10][11][12]}.

Courses

We taught the parallel courses at two high schools to a total of five classes. Two of the classes were computer applications classes—Word, Excel, PowerPoint. Both of these groups, of which few students had any programming experience, completed the Scratch version of the course.

Another two classes were programming courses—a mix of first, second and third semester programming students. These groups completed the Arduino version of the course. The final class was a manufacturing concepts class that included a section on electronics. This group completed sections 1 – 4 of both the Scratch and Arduino versions of the course.

The course itself was divided in to five sections – introduction, variables, conditionals, iteration and functions. Each section included a short 10-minute lecture introducing the given concept through analogy and examples. The rest of the time (between 40 – 70 minutes, depending on the school, course and day) was spent with the students working on a lab exercise either individually or in small groups, depending on available resources.

The Scratch and Arduino labs are described in Table 1.

Lab	Scratch	Arduino
<i>1 – Introduction</i>	Create animation with multiple sprites.	Blink LED off and on.
<i>2 - Variables</i>	Create MadLibs-style word game, using variables to store user-entered data.	Use potentiometer to create dimmer light switch.
<i>3 – Conditionals</i>	Create animated tag game with user controls based on keyboard input.	Create push button light switch to control an LED.
<i>4 – Iteration</i>	Create interactive musical animation with multiple sounds.	Play a song using a Piezo buzzer.
<i>5 – Functions</i>	Create calculator with sum and average functions.	Read temperature (in °C) and write function to convert to °F.

Table 1: Labs

For the Scratch labs, students built game-like programs. In each, they were able to either draw their own sprites (graphical programmatic elements) or use Scratch-provided sprites. Many students chose to spend time drawing their own sprites. In the fourth lab, we explicitly asked students to include sound in to their program; however, most had already been using sound starting with the first program. Students also discovered that they could download others' Scratch programs from the Scratch website and incorporate parts of those programs into their own or extend those programs.

The Arduino labs required much more work to set up. Before each session, we had to wire up the boards, LEDs and other electronic components. One significant challenge these classes faced was getting their lab computers to communicate with the Arduino boards. It took us the first couple sessions to iron out all the problems with the Arduino drivers. And once all the boards were set up correctly, it was easy for students to jostle the boards enough to loosen wires. Once wires came undone, students did not have enough electronics background to read the provided wiring diagrams.

Survey

Feedback on the course was gathered through a short (10 -15-minute) pre- and post-survey. The pre-survey contained a subset of questions from the post-survey. Of the five groups, three groups reported an increase in "comfort with computing," while two groups (one working with Scratch the other with both Scratch and Arduino) related a decrease in comfort.

In all groups, there were a total of 119 participants. Of those participants, 93 completed the pre-survey (78.15%) and 85 (71.43%) the post-survey; 59 (49.58%) completed both the pre- and post-surveys, 34 (28.57%) only the pre-survey and 26 (21.85%) only the post-survey.

Overall, we question the accuracy of the survey answers—for instance, in one case, a student lost

an entire year of programming experience between taking the pre-survey and the post-survey, six weeks apart. This points out the possibility that students were confused by the survey questions. In addition, students were not given any class credit for participation, program or survey completion.

The quantitative objective learning assessments came back with mixed results for both Scratch and Arduino. Some students showed an improvement in answering the questions correctly after going through the course; however, other student which had initially answered the questions correctly in the pre-survey, failed to answer them in the post-survey.

At the end of the following code, what is c equal to? $a = 3$ $b = a - 1$ $a = b * 2$ $c = a + b + 1$ c is _____

Table 2: Sample quantitative survey question

From the students free-form comments on the course, the most common things students liked was that the course was "fun" and "interesting." The dislikes included that the course was "too hard," "boring" and "confusing". Students from the Scratch courses frequently mentioned enjoying drawing their own sprites and being able to add sounds into their programs. On the other hand, students in the Arduino courses expressed frustration at getting their Arduino boards to work at all with their computers.

A full listing of survey questions and responses can be found in [13].

Future Work

We found two interesting areas of future work—first, to further the study in a controlled environment such that the outcomes for the two groups (Scratch learners and Arduino learners) could be directly compared; and next, to study how students translate learnings from the two courses into further course work—either AP Computer Science in Java or CS1 courses in a university.

Conclusion

Based on our observances in the two parallel courses, we conclude that Arduino is not a suitable platform for teaching introductory programming to high school students. The platform overwhelmed the novice students with the addition of the hardware element to the software element. Scratch was much easier for the new programmers to pick up quickly, with the exception of the fifth lab (functions in BYOB), which proved to be overly complex.

Both high schools, though, will continue to integrate more computing in to their classes. They intend to use Scratch in their computer applications classes and Arduino in their programming classes, after an introduction through Scratch.

References

1. "Overview \ Processing.org." [Online]. Available: <http://processing.org/about/>. [Accessed: 09-Apr-2012].
2. "Scratch Homepage." [Online]. Available: <http://scratch.mit.edu/>. [Accessed: 09-Apr-2012].
3. A. Robins, J. Rountree, and N. Rountree, "Learning and teaching programming: A review and discussion," *Computer Science Education*, vol. 13, no. 2, pp. 137–172, 2003.
4. L. McIver and D. Conway, "Seven deadly sins of introductory programming language design," in *Software Engineering: Education and Practice*, 1996. Proceedings. International Conference, 1996, pp. 309–316.
5. R. D. Pea, "Language-independent conceptual 'bugs' in novice programming," *Journal of Educational Computing Research*, vol. 2, no. 1, pp. 25–36, 1986.
6. C. M. Lewis, "How programming environment shapes perception, learning and goals: logo vs. scratch," in *Proceedings of the 41st ACM technical symposium on Computer science education*, New York, NY, USA, 2010, pp. 346–350.
7. O. Meerbaum-Salant, M. Armoni, and M. Ben-Ari, "Habits of programming in scratch," in *Proceedings of the 16th annual joint conference on Innovation and technology in computer science education*, 2011, pp. 168–172.
8. M. Rizvi, T. Humphries, D. Major, M. Jones, and H. Lauzun, "A CS0 course using Scratch," *J. Comput. Sci. Coll.*, vol. 26, no. 3, pp. 19–27, Jan. 2011.
9. O. Meerbaum-Salant, M. Armoni, and M. M. Ben-Ari, "Learning computer science concepts with scratch," in *Proceedings of the Sixth international workshop on Computing education research*, 2010, pp. 69–76.
10. P. Bender and K. Kussmann, "Arduino based projects in the computer science capstone course," *J. Comput. Sci. Coll.*, vol. 27, no. 5, pp. 152–157, May 2012.
11. P. Jamieson, "Arduino for Teaching Embedded Systems. Are Computer Scientists and Engineering Educators Missing the Boat?," in *International Conference on Frontiers in Education: Computer Science and Computer Engineering*, 2011.
12. R. Balogh, "Educational robotic platform based on arduino," in *Proceedings of the 1st international conference on Robotics in Education, RiE2010*. FEI STU, Slovakia, 2010, pp. 119–122.
13. "Build Your Own Blocks Homepage." [Online]. Available: [http:// http://byob.berkeley.edu/](http://http://byob.berkeley.edu/). [Accessed: 05-Jan-2013].
14. A. Beug, "Teaching Introductory Programming Concepts: A Comparison of Scratch and Arduino." [Online]. Available [Accessed: 03-10-2013].
15. J. Sarik and I. Kymissis, "Lab kits using the Arduino prototyping platform," in *Frontiers in Education Conference (FIE), 2010 IEEE*, 2010, p. T3C-1 –T3C-5.
16. M. Resnick, J. Maloney, A. Monroy-Hernández, N. Rusk, E. Eastmond, K. Brennan, A. Millner, E. Rosenbaum, J. Silver, B. Silverman, and Y. Kafai, "Scratch: programming for all," *Commun. ACM*, vol. 52, no. 11, pp. 60–67, Nov. 2009.
17. D. J. Malan and H. H. Leitner, "Scratch for budding computer scientists," in *Proceedings of the 38th SIGCSE technical symposium on Computer science education*, New York, NY, USA, 2007, pp. 223–227.
18. U. Wolz, H. H. Leitner, D. J. Malan, and J. Maloney, "Starting with scratch in CS1," *ACM SIGCSE Bulletin*, vol. 41, no. 1, pp. 2–3, 2009.

18. U. Wolz, J. Maloney, and S. M. Pulimood, “ ‘Scratch’ your way to introductory CS,” *ACM SIGCSE Bulletin*, vol. 40, no. 1, pp. 298–299, 2008.
19. “Alice.org,” *Alice.org*. [Online]. Available: <http://alice.org/>. [Accessed: 28-May-2012].

Professional Development of University Engineering Faculty through a Math-Science Partnership

Kurt McMullin, Thalia Anagnos, Jan Hustler and Nancy Thomas,
San Jose Staté University / Partnership for Student Success in Science

Abstract

A six-year partnership of nine school districts, the engineering and education colleges of a local university, and two industry partners was formed in the San José region to provide professional development for K-8 science teachers and university engineering faculty members. Professional development for the K-8 teachers was delivered via Summer Institutes, academic year workshops, and development of site-based study groups. This professional development work was led by trained K-8 professional developers in partnership with engineering faculty from the Institution of Higher Education partner. While working with the K-8 teachers, engineering faculty members also enhanced their pedagogical methods. Positive changes in teaching of engineering courses by the university faculty members were observed, including increased student-led inquiry, use of pre-assessment techniques, student-learning assessment, enhanced student probing, development of a university study-group to explore teaching of experimental design, and development of pedagogical content knowledge for basic engineering courses. Findings include identifying key elements of successful professional development programs, examples of the enhanced teaching practices of engineering faculty, development of a standard evaluation rubric for experimental design skills, development of educational standards for courses, and the development of preliminary concepts of pedagogical content knowledge related to engineering mechanics courses.

Introduction

Developing strong pedagogical skills in engineering faculty members is a critical component of enhancing engineering education. During the period 2003 to 2009, a National Science Foundation funded Math-Science Partnership⁹ in the San José, California region invested time, money and effort in developing pedagogical skills in both K-8 educators and engineering faculty. The goals of the national initiative included the enhancement of educators at San José State University, the IHE partner (Institution of Higher Education)⁹. Initially, the Project Management team was hesitant in their expectations that the project would be able to contribute to this goal. However, as the project evolved, it became evident that the IHE faculty was implementing improved pedagogical practices in their teaching.

To achieve their objectives, the Partnership for Student Success in Science (PS³) worked toward three goals, targeted primarily at the K-8 schools but related to work at the IHE:

1. Raise the overall science achievement in all PS³ schools and narrow the achievement gap between lower-performing, high-priority schools and their higher performing counterparts.
2. Improve the capacity of pre-service and in-service teachers to deliver high quality science instruction.
3. Build the critical system supports necessary to help teachers achieve improved instruction and student success.

The project invested the majority of its resources into professional development of K-8 educators however, the involvement of engineering faculty as content experts in the professional development trainings over several years contributed to the additional outcome of strengthening their pedagogical skills.

The Partnership: The Partnership consisted of nine Silicon Valley school districts, San José State University's (SJSU) Colleges of Engineering and Education, and two local industry sponsors. Science teaching and learning, grades K-8, was improved through a continuum of training. Typical professional development for in-service teachers included one-week summer science institutes, one-day workshops, and personal mentoring.

The professional development for the K-8 teachers was designed and organized by master teachers from the districts. Engineering faculty members contributed to these professional development activities in multiple ways:

- Two faculty members were the STEM content experts at some of the summer institutes. This role required them to be actively engaged in the design and development of the institute as well as being an instructor during the week. Design and development required significant involvement over the four months prior to the institute while the goals of the training, the content emphasis and the pedagogical modeling were determined. Development and use of pre- and post-test assessment of the participants was designed, conducted and evaluated.
- The four faculty members attended and assisted with many of the one-day workshops. During these workshops, the IHE participant usually did not have a formal role in the professional development but served as a resource to the master trainers. These informal interactions allowed the IHE participants to discuss educational issues face-to-face, mentor individual educators, and observe successful pedagogical models.
- One IHE faculty member worked one-on-one with several teachers in drafting funding proposals to collect resources for the K-8 classroom. Teachers had limited prior experience on writing successful funding proposals and working with the engineering faculty members they were given support to define need and craft a successful proposal for sponsoring agencies.
- Engineering faculty partners were also involved with the overall project management, the evaluation of assessed data, the presentation of findings at various conferences, and the problem solving sessions used to adjust the project progress. Working as a member of the project management team involved in-depth discussion with educational researchers, allowing a very insightful introduction into large-scale evaluation and reform. In addition, this discussion provided resources such as research-rich teaching evaluation methodologies, nationally developed learning assessment tools, and participation at national science education reform trainings.

Reaching the Project Goals

The project had significant impact on the pedagogical skills and methods used by the engineering faculty. The Project Management team had expected that impact on IHE teaching practices would be limited, particularly considering that the focus on the K-8 science content would be tangential to the content expertise of the IHE faculty. However, expertise in content does not

necessitate expertise in pedagogical skills, and while the IHE faculty involved in the project all had prior training and interest in developing strong pedagogical skills, it was observed that pedagogical expertise of the K-8 teachers transferred to the engineering faculty in both formal and informal means.

The engineering faculty partners were motivated to improve their pedagogical skills for both informal and formal reasons. Informally, the four faculty members felt that they needed to be the best instructors they could be to allow their students to achieve the defined educational outcomes of their classes. Formally, the need to meet ABET assessment requirements¹ was a strong motivator for the engineering college to strengthen the use of student achievement data collection, analysis of results, and implementation of improved instruction. Initially, the project envisioned a series of pedagogical workshops to be held at San José State. The goal was to develop and deliver a two-hour workshop each semester over the life of the project. The first of these workshops was held in Fall 2004 and provided guidance on the Inquiry Spectrum, the variation of learning environments from direct instruction to student defined inquiry. While the workshop was successful and attracted approximately 25 IHE instructors and resulted in increased use of inquiry and student-led discovery in several of the mechanical and aerospace engineering courses³, the Project Management team subsequently refined their work plan. An underlying concept governing the Project Management decisions was that professional development would generally require about 100 hours of training to make notable changes in classroom practice. The IHE workshop strategy would have only provided about ten hours of training over several years and even when combined with a comparable amount of time for individual reflection, would have resulted in far less than this 100-hour threshold. Thus, the Project Management team in consultation with the IHE college administration determined that a wiser investment of their limited resources would be to strengthen the skills of the engineering faculty who were directly involved in the project, and having that enhancement transfer to other members of the college through peer-to-peer interaction.

Over the course of the project, changes in pedagogical skills of the engineering faculty were observed^{2, 3, 6, 7}:

1. Use of pre-test evaluations to monitor student skills prior to instruction.
2. Improved use of data collection and evaluation of student learning.
3. Changes in educator perception of teaching skills and classroom culture.
4. Use of professional study groups for development of rubrics to evaluate student skills quantitatively suitable for use in a wide variety of courses.
5. Conversion of classroom instruction from a teacher-centered to a learner-centered environment.
6. Development of pedagogical content knowledge (PCK) of engineering curriculum.

Pre-Testing: Improved use of pre-test evaluation of student skills were implemented into the teaching of two engineering mechanics courses by one of the IHE faculty participants. A standard method of evaluation was developed for the beginning of the semester by selecting a portion of the nationally developed Force Concept Inventory⁵ instrument. Figure 1 provides a summary of the student performance on different questions of that assessment instrument.

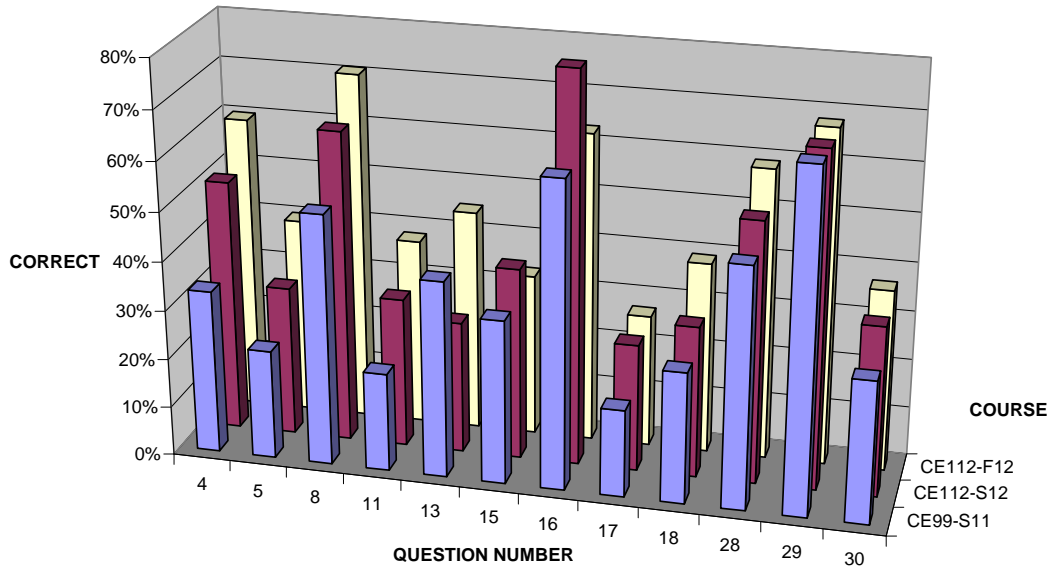

Figure 1. Student Performance on Force Concept Inventory Pre-Test Evaluation

Pre- and post testing is used for course outcomes assessment in technical writing, a required course for all engineering students⁷. In this course, the pre-test is a standardized writing skills test (WST) administered by the university to determine if students have adequate grammar and writing skills to be successful in the technical writing course. Students who earn below a 6 (on a 12-points scale) on the essay must take the test again and are offered several options to remediate their grammar and writing deficiencies. At the end of the course students complete a similar prompt-driven essay that is scored by using the same rubric. Students who did not earn at least a 6 must retake the technical writing course. A comparison of scores on the pre- and post-tests is used to evaluate the effectiveness of the course in achieving its stated learning outcomes. Figure 2 shows the average gains from pre-test to post-test. Students with lower pre-test scores (6 and 7) show the greatest gain.

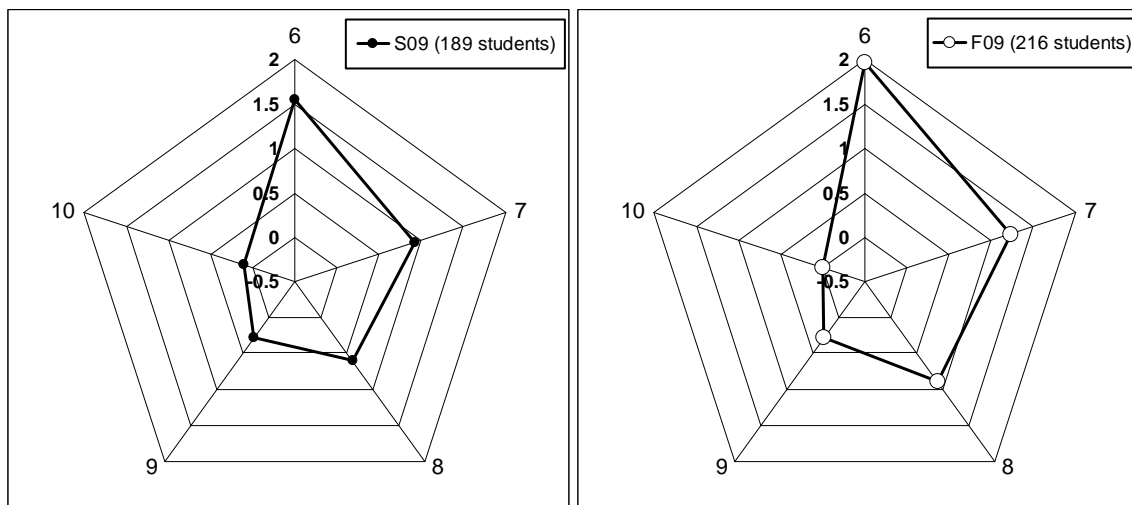

Figure 2. Gains on technical writing essay. The spokes represent the score on the pre-test (passing scores range from 6 to 12). The concentric pentagons represent the average gain⁷.

Data Collection and Analysis: Engineering faculty members are very familiar with collection and evaluation of data due to their content research backgrounds. However, they usually have limited experience with comparable data evaluation in monitoring teaching skills. While interacting with a wide spectrum of educators during the project, aspects of data collection were noted. The use of research-based evaluative techniques during the K-8 professional development (Love, 2002), educated the IHE partners about formal methods of processing educational data. Specifically, aspects of this data processing for use in the ABET process were noted:

- The commonality of assessment processes to collect too much data in a form that is not conducive to evaluating the impact of individual enhancements.
- The limitations of data to capture the multiple influences on a student's ability to complete a task.
- The advantages of longitudinal tracking of student success as opposed to the evaluation of course performance by different cohorts of students.
- The statistical challenge of collecting enough data to establish direct correlations between student achievement and instructional practice.

Love⁸ discussed the evolutionary stages of assessment processes. She also provides guidance on the usefulness of data-driven dialog. Of particular interest to the IHE partners were these points from her guideline:

- Data can help evaluate program effectiveness.
- Data can provide feedback to teachers and administrators.
- Data can prevent overreliance on standardized tests. Some civil engineering programs have tried to use the EIT exam results as a means of evaluating engineering education success. Love clarifies that while these results are useful in the assessment process, they are limited in their ability to identify learning weaknesses.
- Data can prevent one-size-fits-all solutions. While certain aspects of teaching skills may be easily transferred across universities, many meaningful enhancements must be developed locally to reflect the needs and resources of a specific course.

Love also discusses concerns about methods of using data. She warns against using data to identify poor teachers. She also warns about implementing high stakes requirements prematurely, such as having a certain performance on an assessment required for graduation.

Learning the limitations of data analysis was an important professional development outcome for the IHE faculty. An example of data use during the project was the tracking of the student achievement of grade 8 students. Sample sizes of approximately 7000 students per year were not large enough to statistically observe relationships between several factors evaluated. Since engineering colleges do not approach these numbers of students, the outcome of the evaluation was that assessment data should monitor longitudinal trends rather than specific point-in-time assessments. For example, a goal of the college was to see if modifications to a prerequisite would result in improved student performance in the subsequent course. The faculty found several factors limiting the likelihood of seeing a statistical verification of the impact of this change. First is the issue of non-uniform assessment instruments. Data could be collected in the prerequisite technical writing course on a student writing assignment evaluated on a 12-point scale and in the subsequent course student performance on lab write-ups could be evaluated on a different 6-point scale, thus limiting the accuracy of evaluation. Second, the evaluated population was small, approximately 150 students taking the subsequent course annually. Third

was the issue of an unbiased control group. Many students of the benchmark control group already had taken the pre-requisite course prior to it being a required pre-requisite. Thus there was no control group available in which all of the students had not taken technical writing. With these limiting factors, it was unlikely to expect that a statistically valid improvement would be noted; however, tracing trends in student performance over several years may support the validity of the change. Thus, understanding the limitations of assessment data was a critical knowledge gain for educators.

A second example of data use related to considering student achievement in mechanics related to their understanding of Newton’s Laws of Motion. As an initial evaluation, student grades in the mechanics course were compared with how they performed on the Force Concept Inventory⁵ at the beginning of the course. Figure 3 is a comparison of that data. The graph shows a small positive correlation exists, although perhaps weaker than one might expect. Figure 3 considers a population of 82 students over two semesters. More data will be added as more courses are evaluated. Perhaps as the sample population increases, the findings will be more definitive.

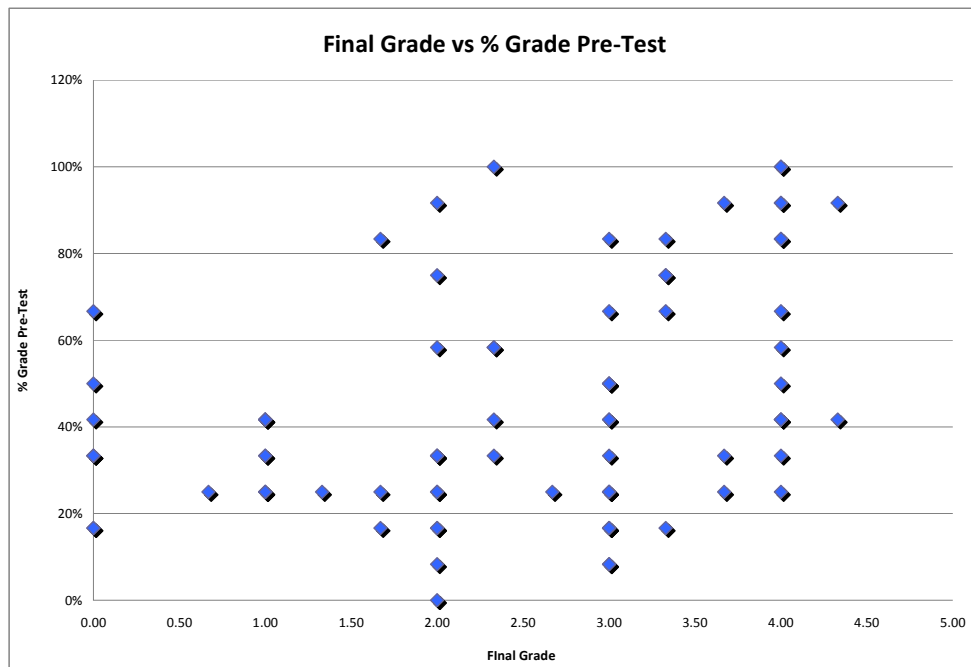

Figure 3. Correlation between Pre-Knowledge of Newton’s Laws and Course Grade (A=4.00) in Mechanics of Materials

University Faculty Study Group: The project used study groups as a means of providing professional development to teachers at the middle schools. Study groups were developed for the middle schools following the Nancy Love⁸ model. For the IHE partner, a study group was formed by the four SJSU engineering faculty to address an issue common to all faculty in the College of Engineering, assessment of ABET outcomes. They focused on ABET outcome 3b “an ability to design experiments.” During AY06/07, the faculty met on a weekly basis to define the pedagogical issues, review the published literature, determine the steps in the design of an experiment, and create a rubric, test it, and refine it. The resulting rubric for design of experiment

was documented in an article² and shared with faculty at other universities as a workshop at the 2007 Frontiers in Education (FIE) Conference.

The study group was a unique and powerful experience. The four faculty members were from different engineering disciplines and did not teach the same courses. However, they quickly discovered that they were all struggling with the same issues related to moving from cookbook to student-designed experiments. Initially, members of the study group identified relevant literature, which everyone reviewed and then discussed at the weekly meetings. The literature review served as a basis for defining the steps of a design of experiment. In particular two faculty members had already done some preliminary thinking about the design of experiments steps and had introduced some adjustments to their laboratory courses^{3, 6}. As the group moved into the phase of formalizing a definition for these steps, each member shared what they did in their own classes. Group members critiqued each other's laboratory assignments and had lively discussions about what really required students to "design" their experiments. Many discussions revolved around levels of proficiency for the rubric. For example for the "select the proper range of independent variables" step, the group discussed at great length the difference between "reasonable" and "optimal" ranges, giving examples from their own experiences. The resulting rubric was clearer and more generally applicable because of the input of this multidisciplinary group. Having the opportunity to discuss course activities in such a supportive and open environment was extremely gratifying and productive.

Changes in Classroom Instruction: Classroom instruction was altered by multiple faculty members after being exposed to enhanced instructional models used by the K-8 master teachers. The use of probing questions by the course instructor during both class period and office hours deepened student understanding. Engineering instructors became more aware of the importance of asking questions of students rather than give direct answers and thus used this technique more frequently and more effectively than previously. These questions are intended to require the student to self-reflect on the 'correctness' of their thinking and see if their thoughts are applicable to other situations. This questioning technique has replaced the instructor's natural tendency to tell the student the correct answer to a question, or to immediately point out an error in the student's reasoning. The goal of the probing question method was to improve a student's ability to reflect on their thinking and self-adjust their conceptual understanding.

Evaluating student knowledge according to conceptual understanding was another alteration in instructional methods. Prior to the interaction with the K-8 educators, the engineering faculty members' often evaluated student using a detail-oriented evaluation. For example, points on an exam calculation problem were given based upon each variable in the calculation being correct or not. While being involved with the project, faculty members began to take a more holistic approach to exam problems, both in the way they were written and the way they were scored. The goal was to develop exam problems that focused less on computation and more on concepts. Grading then moved toward evaluating if the student understood the underlying concept and was able or unable to execute it, and to understand if the student failed to even understand the concept being applied. With computationally heavy problems this type of conceptual evaluation can be lost.

Improved Pedagogical Content Knowledge: Expanding the concept of Pedagogical Content Knowledge (PDK)⁴ and applying it to engineering education was seen as a good investment for faculty time. The ability of engineering students to draw complete and correct Free Body Diagrams (FBD) was seen as a critical skill. Engineering students in the mechanics courses (Statics, Mechanics of Materials, Dynamics, and Fluid Mechanics) frequently use equilibrium concepts to solve engineering problems. The ability to correctly draw a FBD would allow students to perform better in multiple classes, but faculty instructors often commiserate over student's weakness in this skill. To improve on the instruction of this skill, one faculty member made this a key goal for enhancement of his mechanics courses.

To strengthen student skill in drawing FBD, the following steps are being pursued:

1. Clearly identify the characteristics of a good FBD.
2. Distinguish conceptual and application level skills required.
3. Develop an evaluative rubric to consistently grade and monitor student progress.
4. Develop specific assessment tools to monitor student performance.
5. Enhance lectures and instructional materials.
6. Track changes in student performance over time.

Two courses have received the initial attention on this topic, Statics and Mechanics of Materials. One instructor teaches sections of each topic.

Multiple phases of development of this PDK were undertaken. First, five main characteristics of good FBD were defined and emphasized to students. The complete diagram was to include:

1. A neat and roughly scaled sketch of the object isolated from the environment.
2. All known forces with magnitudes, units and sense shown in vector format.
3. All unknown forces with symbol and assumed sense shown in vector format.
4. All critical dimensions required for equilibrium calculations.
5. A coordinate system.

The second phase was to distinguish the skills between conceptual (identifying applied forces and moments, isolating an object, representing reactions as unknown quantities, identifying and resolving critical dimensions) and implementational (adding coordinate system for clarification, units, neatness). The third phase was to develop the rubric listed in Table 1. For the fourth phase, one exam problem of each exam (two midterms and a final) required the students to explicitly draw a complete FBD needed for the problem. This FBD was assigned points and graded separately from the main problem; i.e. students might correctly calculate the numeric solution to the problem but if the FBD diagram was incorrect they would not earn full credit for the problem. While students are encouraged to draw FBD for all problems on exams, FBD are not always required to allow students flexibility in their time management during the exam. The fifth phase of improving instructional practice continues, but as a start, the five FBD characteristics are recited by the class several times during the semester and students are expected to have memorized the items prior to the first midterm. As a visual clue, the instructor uses five fingers to indicate the five characteristics in a consistent order to improve student retention abilities. Table 2 lists some observed trends in student performance.

Table 1. Rubric for Free Body Diagrams

Score	Performance	Examples
100%	Solution is correct and complete	Object cut loose from the environment; known forces w/magnitude, sense and units; unknown forces w/symbol and assumed direction; critical dimensions to solve for equilibrium; coordinate system
90%	One minor error	Solution is missing or has incorrect information for one of the following: coordinate system, units on known forces, units on dimensions, symbols for unknown forces
70%	More than one minor error	Solution is missing or has incorrect information for more than one of the following: coordinate system, units on known forces, units on dimensions, symbols for unknown forces
50%	Conceptually correct	FBD contains all forces/moments acting on the object and no more. Sense and magnitude of known forces may be incorrect.
20%	Knowledgeable attempt	FBD contain the majority of forces/moments acting on the object, but the sense or magnitude may be incorrect or there are no more than two nonexistent forces/moments shown.
0%	Minimal solution provided but provided material is conceptually correct.	Page is essentially blank or there is a minority of actual forces/moments shown or more than two nonexistent forces/moments shown.
-20%	Student writes something on exam solution that is conceptually incorrect.	Acceleration or mass values are identified as a force.

Another aspect of PDK is defining why students produce the incorrect result. Preliminary evaluation of the results from the Force Concept Inventory has been conducted. The poorest performance has been on Question 17, related to the relationship of the upward force of the cable on an elevator to the downward force of gravity when the car is traveling upward at a constant speed. Barely 20% of the students correctly identify that the forces are equal while the vast majority expect the upward force to be larger. Questions 15 and 16 both relate to a scenario where a small car is pushing a heavy truck. Both ask for the relationship between the force of the truck on the car and the force of the car on the truck. Students consistently do better on Question 16 where the two vehicles are traveling at a constant rate, but are more likely to not realize the two forces are equal when Question 15 asks them about a situation where the two vehicles are speeding up. Another early observation of the instructor was the very limited use of diagrams by students to make judgments about the correct answers. The assessment is multiple choice and does not require calculation, but consistently, very few students make any type of force drawing on their paper as they try to solve the questions.

Table 2. Trends in Drawing Free Body Diagrams

Term	Observation	Remarks
Spring 2010 Statics Course	60%	Average score on Final Exam for problem requesting students to draw a FBD.
Spring 2012 Mechanics of Materials Course	79%	Average score on Final Exam for problem requesting students to draw a FBD.
Fall 2012 Mechanics of Materials Course	82%	Average score on Final Exam for problem requesting students to draw a FBD.
Fall 2012 Mechanics of Materials Course	60%	Percentage of students who drew a FBD on another problem of the exam to solve a complex stress analysis problem (axial, bending and shear).

Discussion

An important outcome of this project is the two-way professional development that occurs when K-12 and higher education institutions partner to improve student achievement. A typical model is one in which the IHE is assigned the role as the provider and the K-12 institution the receiver. But in fact, both partners can and do learn from each other. Based upon the PS³ project's past work, review of published research and personal experience, the following are designated as key elements for a project of this type to succeed:

1. Focus professional development on Early Adopters. In any faculty group, some instructors are receptive to trying new pedagogical methods and adapting their courses, and other members are not. One administrative need, possibly even more acute at the IHE than the K-8 level, is a way to identify, support, and reward the Early Adopters. Educational reform will start with the Early Adopters, expand with the sharing of those changes with other instructors, and likely skip over the more incalcitrant members of the faculty.
2. Support a highly motivated, visionary Project Director with commitment to project success. It is critical that the Project Director have sufficient time and resources to build alliances, communicate project work, coordinate meetings, and review project success. The authors believe that one of the prime reasons for the success of the project was a highly-capable Project Director, who was provided adequate resources to devote her talents full-time to this project.
3. Assign professional development responsibilities to K-12 Content Resource Teachers. Content Resource Teachers designed and delivered professional development through formal workshops, one-on-one mentoring, and collaborative team support. The project's resources allowed the content teachers be released from classroom teaching assignments during the project. This allowed for the team of resource teachers to meet with local teachers, meet as a team to develop and deliver high-quality professional development, review relevant research and strengthen their own content and pedagogical skills.
4. Support site-based Collaborative Teams of teachers. New strategies will be reinforced and therefore more rapidly institutionalized when there is a critical mass of content-specific educators at an individual school site who have a self-motivation for school reform, student success, and collaborative spirit. A minimum of 50% of content-specific instructors at a school are envisioned for a Collaborative Team for each participating grade level.

5. Enlist District/Administrative support. Leadership, administrative, and financial support from participating school districts is essential to motivate teacher participation, recognize local achievement, assist in project guidance, and provide instructional materials.
6. Provide stipends for teacher participants. Financial stipends are critical to attract teachers to professional development, reward them for their time commitment, and honor their work for school and student improvement.

Acknowledgements

This material is based upon work supported by the National Science Foundation through Cooperative Agreement No. EHR-0315041. Additional support was provided by the San José State College of Engineering. Any opinions, findings, and conclusions or recommendations expressed in this material are those of the authors and do not necessarily reflect those of the National Science Foundation or San José State University.

References

1. ABET. (2012). *Criteria for Accrediting Engineering Programs 2013-2014*. Engineering Accreditation Commission. Baltimore, Md. Retrieved Nov. 11, 2012 from <http://www.abet.org/accreditation-criteria-policies-documents/>
2. Anagnos, T., Komives, C., Mourtos, N., & McMullin, K. (2007). Evaluating Student Mastery of Design of Experiment, *37th ASEE Frontiers in Education Conf.*, Milwaukee, WI.
3. Du, W. Y., Furman, B. J., & Mourtos, N. J. (2005). On the ability to design engineering experiments, *8th UICEE Annual Conference on Engineering Education*, Kingston, Jamaica.
4. Gess-Newsome, J., & Lederman, N. (1999). *Examining Pedagogical Content Knowledge*. Boston: Kluwer Publishing.
5. Halloun, Ibrahim & Hestenes, David. (1985). The initial knowledge state of college physics students. *American Journal of Physics*, Volume 53 (11), 1143-1055.
6. Komives, C., Mourtos, N. Anagnos, T., & McMullin, K. (2006). Enhancing Inquiry Skills in Engineering through a University-School District Partnership, *Proc. 9th Int. Conf. Eng. Ed.*, San Juan, Puerto Rico.
7. Linsdell, J., & Anagnos, T. (2011) Motivating Technical Writing through Study of the Environment, *J. Professional Issues in Eng. Ed. and Practice*, ASCE, V137, 20-27.
8. Love, Nancy. (2002). *Using Data/ Getting Results: A Practical Guide for School Improvement in Mathematics and Science*. Christopher-Gordon Publishers, Inc., Norwood, MA.
9. National Science Foundation (2013). Math and Science Partnership. http://www.nsf.gov/funding/pgm_summ.jsp?pims_id=5756&org=ehr