

# ***Educating Next Generation Engineers***

ASEE/PSW-2009 Conference Proceedings

ASEE/PSW-2009 Conference

March 19-20, 2009



Host



National University, San Diego, California

<http://www.nu.edu/>

Sponsors



<http://www.avalonrf.com/>



<http://www.labcorp.edu.com/>



<http://nucri.nu.edu/>

Edited by

Mohammad Amin and Pradip Peter Dey

## Preface

Welcome to the 2009 American Society for Engineering Education-Pacific Southwest (ASEE-PSW) regional conference. The theme of this conference is “*Educating Next Generation Engineers*”. We as university/college educators are responsible and continuously striving to prepare the next-generation engineers who will be ready to face the multi-faceted challenges required to move this nation forward. This conference is intended to bring together educators, researchers and practitioners from industry, academia and government to advance engineering and technology education and to encourage wider collaboration between academics and industry. The conference is held for the engineering community and hosted by National University. The large number of submitted papers is a clear indication of enthusiastic cooperation and response from the community. Out of the 70+ submissions, 46 full papers were accepted based on the reviewers’ comments and recommendations. Each submission was reviewed carefully twice (abstract first followed by full paper) by two to four reviewers. These reviewers not only reviewed papers, but also provided their help and support to many young faculty members in order to prepare the final manuscripts. The program committee made their best efforts to accommodate all submissions with academic merit and scholarship.

Many recognized speakers will present their research contributions in their respective fields. In addition, a number of distinguished keynote speakers known both nationally and internationally will deliver their lectures and a group of panelists will attend to discuss the following topic: “*Agile Problem Driven Teaching in Engineering, Science and Technology.*”

We gratefully acknowledge all the support and help that we have received from the members of the ASEE-PSW Board of Director especially the Chair, Dr. Debra Larson for allowing this conference to be hosted by National University. We also recognize and show our gratitude to ASEE administration for their cooperation and support. We would like to acknowledge the support and cooperation of all the authors and reviewers of the ASEE-PSW-2009 Conference.

We are grateful to Dr. Howard Evans, Dean, School of Engineering and Technology, National University, for his welcome address on March 19, 2009 and his help and guidance during the planning and preparation period of the conference. We are also grateful to the keynote speakers: Dr. Marvin White, Professor and Director at Lehigh University, Allentown, PA; Dr. Shu Chien, University Professor and Director at University of California, San Diego, CA; and Dr. Melissa Micou, a young talented faculty member in the Department of Bioengineering, University of California, San Diego, CA. We would like to express our sincere gratitude to Dr. Thomas MacCalla, VP, National University and Executive Director, NUCRI, for his support and a special presentation at the dinner. It is our privilege to welcome Dr. David Hayhurst, Dean, College of Engineering, San Diego State University, for his concluding speech.

Our special thanks to Dr. Jerry Lee, Chancellor of the National University System, Dr. Dana Gibson, President, National University, Dr. Tom Green, Provost, National University, Dr. Mel Green, Professor, University of California, San Diego, all SOET faculty and staff, and sponsors for their valuable suggestions and support. Thank you.

**ASEE/PSW-2009 Conference Committee**  
**San Diego, California**  
**March 19, 2009**

## **ASEE-PSW-2009 Conference Organizing Committee**

**Conference Chair:** Dr. Mohammad Amin, National University  
**Conference Co-chair:** Dr. Lal Tummala, San Diego State University  
**Conference Chief Advisor:** Dr. Pradip Dey, National University  
**Conference Host:** Dr. Howard Evans, SOET Dean, National University  
**Event Management Chair:** Professor Albert Cruz, National University  
**Conference Moderator:** Dr. Thomas Gatton, National University

### **Committee Members**

Dr. Mudasser Wyne, National University  
 Dr. Alireza Farahani, National University  
 Dr. Gordon Romney, National University  
 Dr. Shekar Viswanathan, National University  
 Dr. Ron Uhlig, National University  
 Dr. Samuel Afuwape, National University  
 Dr. Peilin Fu, National University  
 Prof. John Bugado, National University  
 Dr. Raqibul Mostafa, Qualcomm  
 Dr. Hassan Badkoobehi, National University  
 Dr. Debra Larson, Northern Arizona University  
 Dr. Gemunu Happawana, CSU- Fresno  
 Dr. Eric Wang, University of Nevada- Reno  
 Dr. Kurt Colvin, Cal Poly - Pomona  
 Dr. Amelito Enriquez, Canada College  
 Dr. Eniko Enikov, University of Arizona  
 Dr. Kyle Watson, University of the Pacific  
 Mr. Micah Lande, Stanford University  
 Dr. Estelle Eke, CSU-Sacramento  
 Prof. Sanjida Khanam, ITT-Alabama  
 Dr. Shazzad Aslam-Mir, Senior Consultant  
 Dr. Abu Sadeque, Arena Pharmaceutical Inc.  
 Dr. Kiran George, CSU-Fullerton  
 Dr. Thomas Maccalla, NUCRI  
 Dr. Arun Datta, NUCRI  
 Dr. Brian Self, Cal Poly San Luis Obispo  
 Dr. Ralph Belcher, National University  
 Dr. Abu S. Amanullah, Olympus Communications  
 Dr. Mohammad A. Alim, Alabama A&M University

## Table of Contents

1. Welcome Address, Dr. Howard Evans, Dean, SOET, National University	6
2. Thank you note from the Conference Chair, Mohammad Amin	7
3. Keynote Speech: Recent Developments in Solid-State Nanostructures, Marvin H. White	8
4. Keynote Speech: How to Succeed as Next-Generation Engineers? Shu Chien	9
5. Dinner Speech: Cultivating Collaboration and Interdisciplinary Practice, Thomas MacCalla	10
6. Keynote Speech: Innovations in Undergraduate Bioengineering Education, Melissa Kurtis Micou	11
7. Concluding Speech: When Did Engineering Become so Cool? Engaging a New Generation, David Hauhurst	12
8. Classifying Student Engineering Design Project Types, Micah Lande	13
9. Learning Communities Improve Retention in Engineering and Computer Science, Raman Menon Unnikrishnan and Ricardo V. Lopez	20
10. Using Tablet PCs to Enhance Student Performance in an Introductory Circuits Course, Amelito Enriquez	32
11. Using an On-line Survey Tool to Streamline Outcomes Assessment, Phillip R. Rosenkrantz	44
12. Photonics Research and Education at California Polytechnic State University, Xiaomin Jin, Dennis Derickson, Simeon Trieu, and Samuel O. Agbo	51
13. Longitudinal Contact with Individual Students as a Route of Encouraging Self-Determination in Chemical Engineers, Paul Blowers	59
14. Distance Learning and Cognitive Load Theory to Enhance Computer Programming for Mechanical Engineers: Qualitative Assessment, Thomas J. Impelluso	70
15. A Junior Level FPGA Course in Digital Design Using Verilog HDL and Altera DE-2 Board For Engineering Technology Students, Tariq Qayyum	80
16. Design, Fabrication, and Analysis of Photodynamic Therapy Monitoring System for use in Esophageal Carcinoma, Gemunu Happawana, Amaranath Premasiri and Arye Rosen	89
17. SimzLab - Interactive simulations of physical systems for active individual and team learning, Richard K. Herz and Gregory E. Ogden	102
18. A Conceptual Approach to Developing a Universal Remote Laboratory for Education and Research in Electrical Power Engineering, Hassan Mohamed-Nour	109
19. Use of Concept Maps to Build Student Understanding and Connections Among Course Topics, Paul Blowers	114
20. A Framework for Developing Courses on Engineering and Technology for Non-Engineers, Vince Bertsch, John Krupczak, Kate Disney, Elsa Garmire, and Tim Simpson	136
21. Computer Applications in Mechanical Engineering, Estelle M. Eke	150
22. Teaming Multi-level Classes on Industry Projects, Lizabeth Schlemer and Jose Macedo	162
23. Redevelopment of a Systems Engineering Course into Blended (Hybrid) Mode, Kurt Colvin	172
24. Laboratory Projects Appropriate for Non-Engineers and Freshman Engineering Students, Kate Disney and John Krupczak	179
25. Multipoint Remote Temperature Monitoring and Data Acquisition System Using RF Technology, Reza Raeisi and Deepak Anand	189
26. Agile Problem Driven Teaching in Engineering, Science and Technology, Pradip Peter Dey, Thomas M. Gatton, Mohammad N. Amin, Mudasser F. Wyne, Gordon W. Romney, Alireza Farahani, Arun Datta, Hassan Badkoobehi, Ralph Belcher, Ogun Tigli and Albert P. Cruz	197
27. Prerequisite Skills Testing as an Indicator of Student Retention, David Lanning	213
28. The Capstone Design Experience in the Mechanical Engineering Department at California State University-Fullerton, Jesa H Kreiner, Peter W. Othmer and Timothy Lancey	223
29. Application and Practice of Sustainable Development in Engineering, Hassan Badkoobehi	231
30. Is There a Correlation Between Conceptual Understanding and Procedural Knowledge in Introductory Dynamics? Lora Goodwin, Brian P. Self, and James Widmann	234
31. Teaching Classical Control to Mechanical Engineers via Take-Home Experimental Setup Based on Microcontrollers, Vasco D. Polyzoov, Eniko T. Enikov	242
32. Using Model Eliciting Activities in a Dynamics Course, Teresa M. Ogletree, Brian P. Self, and James Widmann	248

33. Development of a Student-Centered Hands-on Laboratory Experiment of Chemical Detection using Micro-cantilever Sensor and Optical Lever Amplification Technique, Geon S. Seo and Eniko T. Enikov	273
34. Modeling the Dynamics of a Small Catapult to Enhance Undergraduate Studies, Lawrence Fong and Brian Self	283
35. Finite Element Analysis Tutorials for an Undergraduate Heat Transfer Course, Kyle A. Watson and Ashland O. Brown	292
36. The Role of Computing in Education: The Next Revolution, Frederick Harris, Gordon Lee, Stuart H. Rubin, T.C. Ting, Billy Gaston and Gongzhu Hu	304
37. Potential Value of Toys in Engineering Education, Said Shakerin	313
38. Comparison of BOKI and BOK2 to NAU's Undergraduate Civil Engineering Program, Debra Larson	324
39. Understanding Histograms, Probability and Probability Density Using MATLAB, Gordana Jovanovic Dolecek and Fred Harris	332
40. From Sequential to Parallel, Ranjan K. Sen and Pradip Peter Dey	345
41. MATLAB-Based Demo Program for Discrete-Time Convolution, Gordana Jovanovic Dolecek and Fred Harris	370
42. Expanding Engineering Education through Undergraduate Research Experience in Micro-Robotic Drug Delivery, Eniko T. Enikov and Malcolm T. Gibson	380
43. Towards A Joint Degree Program In Ambient Computing, Yusuf Ozturk, Emrah Orhun, and Chris Bowerman	386
44. Engineering 101: Peer Teaching with LEGO NXT Robotics, Stephen Beck, Joshua Brent, Thomas Brown, Agostino Cala, Eniko T. Enikov, and Richard Lucio III	395
45. Teaching Online in Electrical Engineering; Best Practices Experiences and Myths, Bruno Osorno	401
46. Curricula for Using Waste Tires in Civil Engineering Applications, DingXin Cheng, Joel Arthur and Albert M. Johnson	409
47. Laboratory Projects Introduced in Teaching Manufacturing Processes Course, Jiancheng Liu	422
48. CIERRA and CIBRED for Educating the Next Generation of Engineers, Thomas MacCalla, Jacqueline Caesar, Michael Maxwell, Shay Vanderlaan, Sandra Valencia, Terena Henry, and Matt Leader	426
49. Bio-molecular Engineering Verified by High Sensitivity Detection, Claudia Lee, Andrew Zepfel, Nina Timberlake, Larry Grill, and Sean Gallagher	436
50. CIBRED: Engineering Education on Cyberinfrastructure with Multidisciplinary Approach for Non-Engineering Students, Arun K. Datta, Jacqueline Caesar, Julie Schuman, Stephen Cammer, Daphne Rainey, and Oswald Crasta	444
51. Is "Dewey's Experience" Synonymous with the Current Usage of the Term? Donna M. Schaeffer and Patrick C. Olson	467
52. Integrating Design Application And Communication Skills Into Senior Design Courses, James Helbling	472
53. The Integration of Ruby on Rails As An Agile Teaching Tool in IT Curricula, Gordon Romney	481
54. Problem-based Learning: Implementation of Efficient Two Factor Authentication for University Computer Systems, Gordon W. Romney and Paul Juneau	493

## Welcome by Conference Host



Howard Evans, Ph.D., PE

Dean, School of Engineering and Technology, National University

Thursday, March 19, 2009, 8:45am-9:00 am

Dr. Howard Evans was appointed founding Dean of the School of Engineering and Technology, National University, in October, 2003. He received B.S. degrees in Physics and Chemical Engineering from Brigham Young University, and a Ph.D. in Chemical Engineering Science from the California Institute of Technology.

Dr. Evans has over 20 years of executive and senior technical management experience at 3M and IBM Corporations, primarily leading multidisciplinary, global technical organizations responsible for R&D; new business and market development; manufacturing engineering; quality; environmental, health and safety; and others.

The School of Engineering and Technology at National University currently has over 1000 students enrolled in 17 degree programs. Program areas include computer science, information technology, and information systems; construction engineering technology and construction management; engineering and technology management; systems engineering, environmental engineering, wireless communications, database administration and Homeland security and safety engineering.

Before joining National University Dr. Evans acquired 12+ years of voluntary involvement with higher education, including adjunct teaching and research in engineering at the University of Colorado and formal advisory involvement in both science and engineering at the University of Texas. Other past professional and academic activities include being a founding member and officer in the Central Texas Electronics Association; past chairman of IBM's Materials Shared University Research Committee; Ph.D. Recruiting Coordinator for IBM's Systems Technology Division; and executive sponsor for 3M division's student programs. He has published and presented widely in areas of surface science, electronic materials and processes, project management, and industry/university relations. He holds 4 patents and has received awards for excellence in technical innovation (IBM), technical authorship (IBM), teaching (University of Colorado), and scholarship (National Science Foundation).

## Thank You Note from the Conference Chair



**Mohammad Amin, Ph.D.**

Professor, School of Engineering and Technology, National University

*“One thing that never decreases by sharing is knowledge”*. I would like to express my heartfelt gratitude and sincere appreciation to all the people who were directly and indirectly involved in making this conference successful. Without you, it would not be possible. It was a quite long journey to come to these final days of the conference. I have been looking forward to seeing you all on this special occasion where we will be discussing the future of our students: *the next generation of engineers*. Today I am truly honored and excited to see so many of my colleagues and fellow professors here who are dedicated to this noble mission: to promote and ensure the excellence in engineering education. As the conference chair, I had the privilege to learn a lot about you, your work and contributions in your fields and your organizations. I am very proud to know that we have so many talented and dedicated individuals from diverse backgrounds coming together to achieve the same goals. I am sure together, we can make a difference. *“One thing that has no ending is learning”*.

### **Biography of Mohammad Amin**

Mohammad Amin received his Ph.D. and MS degrees in Electrical Engineering and MS degree in Solid State Physics from Marquette University, Milwaukee, Wisconsin, and M.Sc. and B.Sc. Honors degrees in Physics from the University of Dhaka, Bangladesh. He is currently working as a Professor at National University, San Diego, California. He has published and presented 60+ papers in the areas of electrical engineering applications, computer applications and biotechnology. He has 20+ years experience in teaching engineering, science, and math. He received an R&D award in 1996 from the *R&D Magazine 100 Awards Program* for the new development of *“IS4000 Solder Paste Statistical Process Control (SPC) System”*. He also received the GAANN Doctoral Fellowship for four years during his doctoral studies. He has three US patents on solder paste measurement techniques. He is the co-inventor of *“IS4000 Solder Paste and Residue Measurement System”*, manufactured by Alpha Metal Inc., a Cookson Company. He is a member of ASEE, and IEEE. His current research areas of interest are problem based learning (PBL), wireless communications, database, biotechnology, and electrical sensors.

## Keynote Speaker

### Recent Developments in Solid-State Nanostructures



**Marvin H. White, Ph.D.**

Lehigh University, Bethlehem, PA

Thursday, 9:00am – 9:50am, March 19, 2009

I will present an introduction to Lehigh University <http://www3.lehigh.edu/default.asp> followed by a description of several unique networks of universities in the United States, which offer researchers opportunities to create <http://www.nnin.org/> and model <http://www.nanohub.org/> experimental nanostructures – electronic devices and circuits with feature sizes less than 100nm. I will present an historical overview of the MOS integrated circuit leading to present-day CMOS nanostructures. I will describe our recent research into three different solid-state nanostructures. The first scaled device, a MOS transistor – used in advanced CMOS logic and microprocessors, uses a gate insulator comprised of two films (e.g. 0.5nm of SiO<sub>2</sub> and 1.6nm of HfO<sub>2</sub> – a so-called, high-K dielectric constant insulator), which are grown with atomic layer deposition (ALD). The second scaled device, a MANOS transistor, is a nonvolatile semiconductor memory (NVSM) used in cell phones, iPods, MP3 players, USB mini-drives and a solid-state replacement for hard drives. This device uses a gate insulator comprised of three films (8.0nm Al<sub>2</sub>O<sub>3</sub>, 8.0nm Si<sub>3</sub>N<sub>4</sub>, 2.2nm SiO<sub>2</sub>). The oxide is a ‘tunneling’ barrier, the nitride the ‘storage’ region, and the aluminum oxide a ‘blocking’ barrier. I will discuss the write/erase, retention and endurance characteristics of these devices. I will discuss the modeling and challenges faced by these devices, which are being considered for the 32nm International Technology Roadmap for Semiconductors (ITRS) node <http://www.itrs.net/>. The third nanostructure, a BioMEMS planar implementation of a 3D ‘patch-clamp’ measurement system, characterizes ion transport in ion-channels on a biological cell with a high-gain, transimpedance amplifier to convert kHz, pA ion-channel currents to several volts. Ion-channel understanding is essential for the development of pharmaceutical drugs as ion-channels are linked to more than 40% of human diseases.

#### Biography of Marvin White

Marvin White received a B.S.E. in Engineering Physics and Mathematics, a M.S. degree in Physics from the University of Michigan and a Ph.D. from The Ohio State University. His area of research is the characterization and modeling of solid-state devices, sensors and custom integrated circuits. His recent work addresses charge transport and storage in MANOS multi-dielectric nonvolatile memories, MOS and CMOS nanoelectronic transistor modeling, BioMEMS, and SiC power devices. His teaching areas concern the Analysis and Design of Integrated Circuits for Systems Applications and Advanced Sensors and Semiconductor Devices. He has received several IEEE awards - ISDRS Aldert van der Ziel Award, Masaru Ibuka Consumer Electronics Award, J.J. Ebers Electron Devices Society Award and the IEEE Fellow Award. He is a member of the U.S. National Academy of Engineering. He has published nearly 300 papers with students and colleagues, contributed chapters to 5 books and holds 27 U.S. Patents. Prior to joining Lehigh, he worked at the Westinghouse Electric Corporation on advanced integrated circuits for systems applications. He has taken sabbaticals as a Visiting Fulbright Professor at Louvain la Neuve, Belgium, a Visiting Scientist at the U.S. Naval Research Laboratory and as a Program Director at the U.S. National Science Foundation. He has graduated 33 Ph.D.’s, and 61 M.S. students.



## Keynote Speaker

### How to Succeed as Next-Generation Engineers?



**Shu Chien, M.D., Ph.D.**

University Professor of Bioengineering and Medicine  
 Director, Institute of Engineering in Medicine  
 University of California, San Diego, La Jolla, CA  
 Thursday, 10:00am – 10:50am, March 19, 2009

To become a successful engineer in this time of dynamic changes in the world, it is essential to have a solid core competence and the ability to learn new principles and technologies that continue to evolve. An engineer not only should have a strong foundation of natural sciences, i.e., physics, chemistry and mathematics, but also an excellent ability to communicate and to collaborate with others. Today, the key issues in engineering are closely linked with our society and human health. Therefore, engineering education should be integrative and continuous (life-long). In order to succeed in the engineering profession, it is essential to have the passion and dedication, the eagerness to learn, create, and execute, and the ability to work with others in a team environment.

#### Biography of Shu Chien

Shu Chien received his Ph.D. (1957) in Physiology from Columbia University, MD (1953) from National Taiwan University and Premed (1948) from National Peking University. Currently, he is a University Professor of Bioengineering and Medicine, the Director, Institute of Engineering in Medicine at University of California, San Diego. Prior to joining UC-San Diego, he worked for many well known organizations including Columbia University, National Taiwan University Hospital, Institute of Biomedical Science (Taiwan). He is the founding Chair of the Bioengineering Department at UC- San Diego. He has received more than 50 awards from US, China and other countries. He is associated with more than 20 national and international professional organizations. He has published nine books and 450 scientific journal articles. Please see the following websites for his bio and “Shu Chien Oral History” document (70 pages) published by IEEE:

- 1) [http://www.ieee.org/portal/cms\\_docs\\_iportals/iportals/aboutus/history\\_center/oral\\_history/pdfs/Chien280.pdf](http://www.ieee.org/portal/cms_docs_iportals/iportals/aboutus/history_center/oral_history/pdfs/Chien280.pdf)
- 2) <http://www3.ntu.edu.sg/ICMMB15/download/keynote2B.pdf>

More interesting information can be found from the following book: Shu Chien: Tributes on His 70th Birthday” by: Lanping Amy Sung, Kung-Chung Hu Chien (ISBN: 9789812383839).

**Dinner Speaker****Cultivating Collaboration and Interdisciplinary Practice****Thomas MacCalla, Ed. D.**

Vice-President National University and Executive Director, NUCRI, San Diego, California  
 Thursday, 7:00pm – 7:20pm, March 19, 2009

We pay much attention to preparing future scientist, the next generation of engineers, and the teachers who carry the message, but we also need to focus on collaborative efforts to prepare and engage students K-20 and inform the public to maximize the effort. We know that data and information are gold and, when transformed into knowledge and shared, they become the mint. The task at hand, therefore, is to identify and analyze the resources for desired change and develop a manageable and measurable education, training, and community outreach strategy to bring it about and recognize the value of collaboration and engagement across disciplines and the professions.

**Education**

Bachelor of Social Science (BSS), Fairfield University, Fairfield Connecticut  
 Master of Arts in Educational Administration *and* United States History, Fairfield University, Connecticut  
 Doctor of Education in Curriculum, Instruction, and Supervision, Comparative Education, *and* American Literature, University of California, Los Angeles  
 Post-Doctorate, Social and Regional Planning, University of California, Los Angeles

**Professional Work Experience( this list contains only important positions)**

*2000 –Present:* Executive Director, National University Community Research Institute (NUCRI)  
*Present* National University Vice President, National University, San Diego California  
*1984-2000* Vice President, Multicultural Affairs, National University, San Diego, California  
*1978 -84* Exec. Director, International Institute for Urban and Human Development, San Diego, CA  
*1969-78* Vice President and Professor, US International University,

**Professional Associations**

Board of Trustees, Pacific Graduate School of Psychology, Palo Alto, California, APA and WASC approved Clinical Research Doctoral Program w/ Stanford University Medical School. Founding Steering Committee for the Adv. Tech. and Research Collaboratory for the Americas (ARTCA ) in Costa Rica Member of the HASTAC Leadership Committee (2005-Present) Co-Chaired by Duke University and the University of California Humanities Research Institute at UC Irvine; Coordinator of National University’s HASTAC InCommunity for the HASTAC InFormation Year 2006-2007: “Creative Smart and Community Building” (November 9-11, 2007) Collaborator with the Institute for Computing in the Humanities Arts, and Social Science, (ICHASS) and the National Center for Supercomputing Applications (NCSA) at the University of Illinois, Urbana-Champaign. Member, Association for Integrative Studies (AIS), IEEE and the TeraGrid Campus Champion Program California Space Authority Education Workforce Development and North San Diego Economic Development Council

## Keynote Speaker

### Innovations in Undergraduate Bioengineering Education



**Melissa Kurtis Micou, Ph.D.**

Lecturer of Bioengineering, University of California- San Diego, California

Friday, 10:40am – 11:05am, March 20, 2009

The Department of Bioengineering at the University of California, San Diego has grown dramatically since being established in 1994 as the first Department of Bioengineering in the University of California system. The educational mission of the Department has been to train future bioengineering leaders through inspiring education and dedicated mentorship. To accomplish this mission while training over 800 undergraduate students at any one time, the Department utilizes innovative teaching methods and curricula. This talk will summarize the Department's recent innovations in undergraduate education including the establishment of degree programs in biotechnology and bioinformatics, the incorporation of a capstone design experience with an emphasis on iterative design, and the introduction of cutting-edge technologies including microarray analysis and tissue engineering into core lab courses. Also presented will be an overview of educational initiatives outside the classroom including an NSF-sponsored Research Experience for Undergraduates (REU) program targeted to students from primarily undergraduate institutions, outreach activities with local high schools, and the Annual Bioengineering Day event featuring industry speakers and a Bioengineering Quiz Bowl competition. The strategies employed by UCSD Bioengineering to successfully train a large undergraduate population may be widely applicable as the number and size of Bioengineering/Biomedical Engineering departments across the country continues to grow.

#### Education

Ph.D. (2001) and MS (1998) in Bioengineering, UC- San Diego, La Jolla, CA

B.S.E. (1996) in Biomedical Engineering, Magna Cum Laude, Tulane University, New Orleans, LA

#### Experience

Lecturer, 2007-present, University of California – San Diego, La Jolla, CA

Assistant Professor, 2005-2007, The Cooper Union for the Advancement of Science and Art, New York

Research Assistant Professor, 2003-2005, The Cooper Union for the Advancement of Science and Art, New York

#### Education Grants

National Science Foundation: REU Site: Regenerative Medicine, Multi-Scale Bioengineering, and Systems Biology, recommended for funding 2008

National Science Foundation: Acquisition of Equipment for an Undergraduate Biomedical Engineering Laboratory at The Cooper Union (\$126,240), 2004-2006

#### Awards and Honors

National Institute of General Medical Sciences, NRSA Postdoctoral Fellowship

American Association of University Women, Dissertation Fellowship

Tulane University Dean's Honor Scholar, Full Tuition Scholarship

## Concluding Speaker

### When Did Engineering Become so Cool? Engaging a New Generation.



**Dr. David T. Hayhurst**

Dean, College of Engineering, San Diego State University, San Diego, CA  
Friday, 11:10am – 11:35am, March 20, 2009

Dr. David T. Hayhurst began his tenure as the sixth Dean of the College of Engineering in August 2002. Prior to joining SDSU, he was Dean of the College of Engineering at the University of South Alabama in Mobile, and professor and chair of the Department of Chemical Engineering at Cleveland State University. A native of Massachusetts, he holds a Ph.D. and a bachelor's degree from Worcester Polytechnic Institute and a master's degree in from the Massachusetts Institute of Technology, all in Chemical Engineering.

While working as an academic administrator, Dr. Hayhurst continues to be active in research, specifically in the area of molecular sieve zeolites. He has numerous publications on molecular sieves and holds patents on their synthesis and applications. He has lectured extensively throughout the world on zeolites and was selected by the National Academy of Sciences as a participant for their Inter-Academy Exchange Program with the Academie der Wissenschaften der DDR.

San Diego State University's College of Engineering is home to eight degree programs (Aerospace Engineering, Bioengineering, Civil Engineering, Construction Engineering, Environmental Engineering, Electrical Engineering, Computer Engineering and Mechanical Engineering) and six research centers. It has more than 2,100 students and approximately 55 full-time faculty. In 2007-2008 the College received more than \$2.5 million in external grants and contracts for research and program administration and graduate student support.

In addition to his duties at San Diego State University, Dr. Hayhurst serves on the Workforce/Education Committee of the San Diego Economic Development Corporation, and is a member of the Board of Directors of CONNECT and of the Engineering and General Contractor Foundation. He has been active in K-12 outreach and facilitated the designation of San Diego State University as the California State Affiliate University for Project Lead the Way, a nationally-recognized program for preparing middle and high school students for careers in engineering.

Dr. Hayhurst and his wife, Mari, raise, show and judge AKC champion Great Danes, Whippets and Boxers.

# Classifying Student Engineering Design Project Types

Micah Lande and Larry Leifer  
Center for Design Research  
Stanford University

## Abstract

Mechanical Engineering 310 is a graduate-level product-learning-based mechanical engineering design course at Stanford University that takes its project prompts from sponsoring companies in industry. In the past 30 years, over 325 projects have been presented and worked on by students teams. The nature of these projects has shifted over time from Manufacturing-focused and Test/Tool-focused projects to standalone Product-focused and Human-centered design products and systems. This paper classifies project types and characterizes maps this change over time.

## Introduction

Mechanical Engineering 310 *Global Team-Based Design Innovation with Corporate Partners* is a year-long, graduate-level product-based learning<sup>1</sup> engineering design course based at Stanford University. It is a core course for many students pursuing a Mechanical Engineering Master's Degree with an emphasis on Design Theory and Methodology. The course has projects sponsored by industry and pairs up teams of students at Stanford with similar teams of students at other global universities. Most students come from an undergraduate experience in Mechanical Engineering. As part of their ABET-approved programs they experienced a capstone design course<sup>2</sup> allowing them to synthesize what they learned in their programs.

For researchers at the Center for Design Research at Stanford University, ME310 has long been a laboratory and test bed for design research.<sup>3</sup> Much study has been devoted to how designers design, how they work in teams and tools that can help along the way. Forerunners of ME310 (also labeled ME210, E210, E310) date back, in its current form, to at least 1972. CDR was established in 1985 and research in ME310 has been going on near 25 years. Technology and the expanding appreciation of what design and design thinking can tackle has changed the scope and type of engineering design projects worked on in the course. This paper classifies project types and characterizes this change over time.

## Corporate Project Prompts as a Start

The yearly slate of projects offered in ME310 are wholly dependent on companies from industry proposing and underwriting project proposals. A dedicated course developer solicits and manages the process. Faculty and staff help edit project prompts for scope and appropriateness to the course pedagogy. Student teams are presented with the array of possible topics, rank their choices and are then assigned to them in a *satisficing*<sup>4</sup> approach.

The course is structured to give student teams both the time and freedom to explore their problem-solution space and a safe support system from which to learn how to step through a

design process. Weekly meetings with the course faculty and teaching assistants as well as having a paired industry coach help teams progress. Course milestones are geared towards hands-on prototyping early and students are pushed to work collaboratively with their design team counterparts globally.

**Documentation and Pre-Production Prototype as a Finish**

Assessment of work is heavily weighted on documentation produced throughout the academic year as evidence of the students’ thinking. A final report of a couple hundred pages is generated in the spring and includes the design problem, requirements, design development and specifications for the end solution. It is prototyped by precursors in the fall and winter.

Student teams have project funds of at least \$15,000 and oftentimes outsource part of the fabrication or finish of their final system. The expectation is that their engineered deliverable be a pre-production prototype – a proof of concept that functions as desired with a lot of consideration as to how it would be manufactured.

**Types of Projects**

For a mechanical engineering course, understandably, much of what is produced is a physical, tangible artifact. There are oftentimes components or whole sub-systems that are not mechanical designed but rather include software or mechatronics.

Mabogunje<sup>5</sup> examined ME310 projects in the 1991-1992 and 1992-1993 course cycles. He was able to define 3 types of projects: manufacturing process driven machine design, product driven machine design, and a hybrid of the two, a mixed product and process driven machine design (Table 1).

Table 1 Types of ME310 Projects

<i>by Mabogunje<sup>5</sup></i>	<i>Coding Schema used here</i>
Manufacturing process driven machine design.....	Manufacturing Process
Mixed product & process driven machine design.....	Test/ Tool for Assessment
Product driven machine design.....	Product
	Human-centered design products

Historically this has been able to capture the distribution of project types. With a rise in a human-centered design approach, industry seeking design to solve a wider range of problems and more future-oriented projects, there is a need to introduce a new category of projects that go past the systems optimization and system design but take readily into account the presence of a user engaged in the designed system. It is then necessary to add the category of “Human-centered design products” on top of those that deal mostly with manufacturing process, tests/ tools for assessment and standalone products.

## Mapping to Ways of Thinking Framework

Previous attempts by the authors to classify student activities in the ME310 course has produced a working framework modeling “Ways of Thinking”<sup>6</sup> accessed by engineering students. As shown in Figure 1, it is visually represented as a matrix showing relative position of Design Thinking, Engineering Thinking, Production Thinking, and Future Thinking. Along the Y-axis is a spectrum of incremental innovation to “breakthrough innovation.”<sup>7</sup> Along the X-axis it is measured in time, short-term to long-term. The activity of Design Thinking<sup>8</sup> can be to “solve a problem” with the end results being an “idea” created. For Engineering Thinking<sup>9 10</sup> “making a solution” results in an “artifact or stuff.” Production Thinking<sup>11</sup> allows for the “remaking of a solution” with the results being “facsimiles of stuff” or plans by which to make copies. Future Thinking<sup>12</sup> allows one to “reset the problem” with the outcome being a “question.”

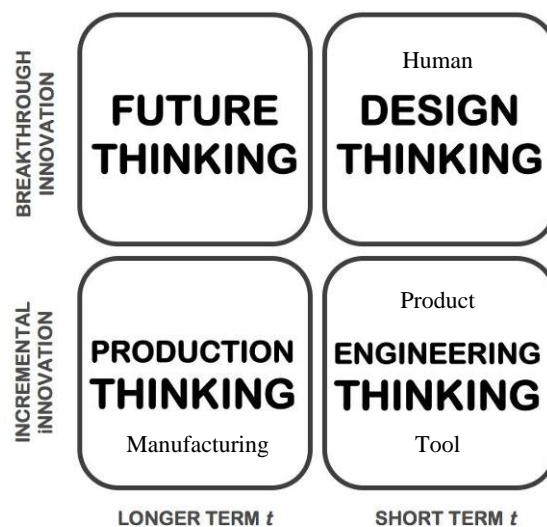


Figure 1 Ways of Thinking Framework for Engineering Design Projects

This maps very closely to the Manufacturing – Test – Product – Human-centered design product coding schema. Figure 1 highlights where these descriptions fall on the “Ways of Thinking” framework.

## Results in Classifying Projects

A survey of 30 years of ME310 projects from AY 1978 to AY 2008 was made. (For the purposes of simplicity academic years are noted by the ending year. AY 2008-2009, for example, would be noted at 2009.) The project title presented at the end of the year was noted and collated. A qualitative coding scheme (listed in Table 1) was applied to classify these projects for their emphasis on a) manufacturing process, b) a test or tool for assessment, c) stand alone product and d) a human-centered product.

Over this time period there were 329 projects with the lowest number of project in any year being 5 (in 1978) and the highest number being 16 (in 1988). The average number of project per year was approximately 11. The distribution of project types is shown in Table 2.

Table 2 Distribution of Project Type by Year

<i>Year</i>	<i>Manufacturing Process</i>	<i>Test/ Tool for Assessment</i>	<i>Product</i>	<i>Human-centered design product</i>	<i>Total</i>
78		2	3		5
79	1	4	1		6
80	2	3	4		9
81	1	2	6		9
82	3	5	2		10
83	2	4	1		7
84	3	6	2		11
85	4	7	3		14
86	2	5	6		13
87	3	7	4		14
88	3	9	4		16
89	3	3	5		11
90	3	6	4		13
91	3	4	5		12
92	5	3	5		13
93	3	4	5		12
94	2	4	9		15
95	4	4	6		14
96	1	6	5	1	13
97		4	10		14
98		2	6		8
99		1	8		9
00		1	7		8
01	1		7		8
02			7	2	9
03			6		6
04			9		9
05		1	8		9
06			4	6	10
07			4	7	11
08		1	6	4	11
<i>total</i>					329

To better visualize the shifting pattern over time the data table was graphed and color coded. In Figure 2 below, from bottom to top in each column, are noted Human-centered design (blue), product (red), test (yellow) and manufacturing (green) projects. The share of projects has shifted over the years. Manufacturing-focused projects have become less common and Human-centered design projects more so. Tool-focused project have also declined while Product-focused projects have grown slightly and fluctuated in recent years.



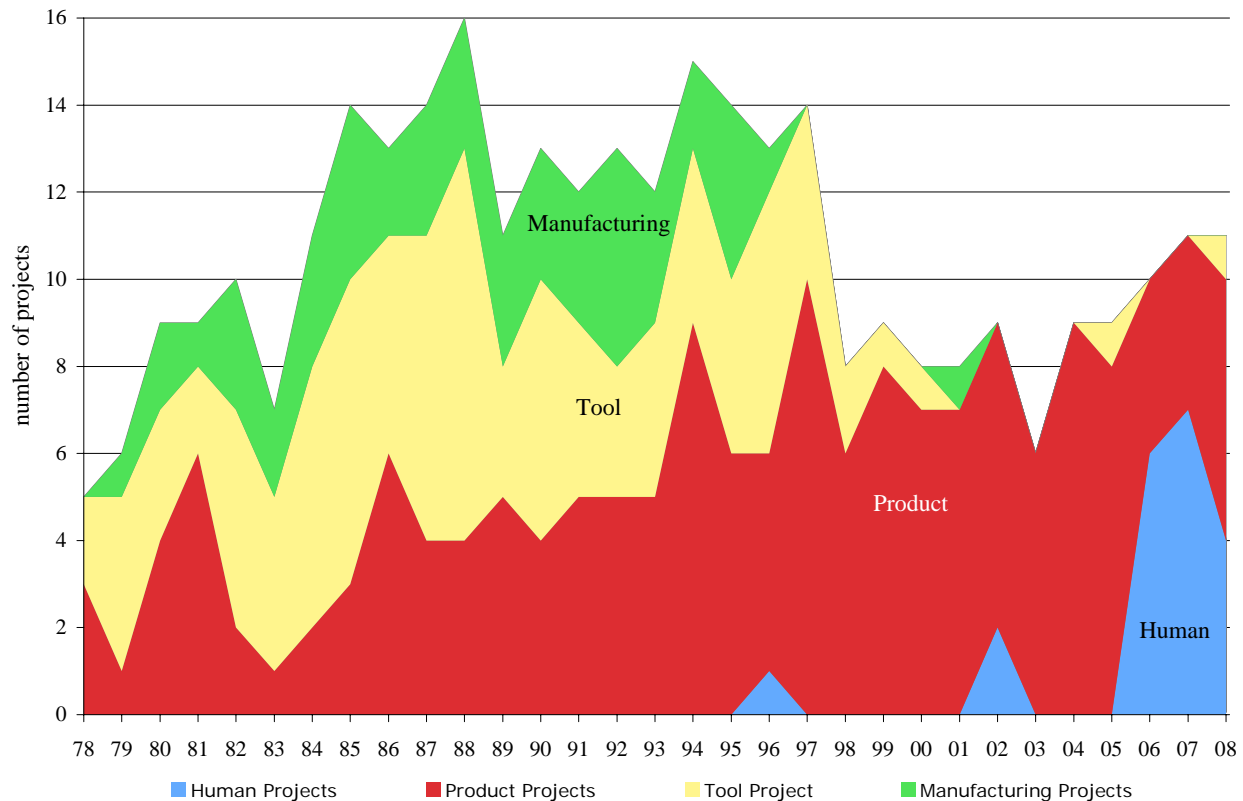


Figure 2 Distribution of Project Types from 1978-2008 ME310 courses

As way of further illustration, Table 3 shows example project content from 3 years of different eras: 1979, 1999, 2006.

Table 3 Selected ME310 Project Content (1979, 1999, 2006)

<u>Projects from 1979</u>	<u>Projects from 1999</u>	<u>Projects from 2006</u>
Design steam leak measurement system	Driver scanning automatic car door	Artificial car co-pilot
High-speed Kevlar wrapper	Innovative composite crutch	Spherical image display
Arm ergometer	Key fob	Enhancing passenger communication
Low-cost facsimile printer	Smart bed	Intuitive remote control
Universal gas seal	Parallel parking assistive system	Reinventing rear seat entertainment
Robotic arm controller	Shift simulator	Future blood glucose meters
	Power expendable towing mirror	Making air conditioning personal
	Inspection device for detection of contaminated blades	Tactile touch screen
		Car shifting system
		Wireless power steering

Projects from 1979 have a propensity of Manufacturing and Test projects. Project titles have terms like “low cost” and “high speed.” Projects selected from 1999 still mostly fall into Product projects. Examples there are systems like Smart Bed and Car Door projects. Projects from 2006 more recently show a human-centered Design approach. There are still a small number of Tool projects like Car Shifting System or pulling power wirelessly from a steering wheel, but most are

with a project centered on people in a car. An interesting thing to note for future exploration is the number of Product and human-centered Design focused projects that ask students to look into the future for the solution space or technology solutions. These include the role of the Artificial Copilot of 2020, Future Blood Glucose Meter and an example of a future display spherical surface.

Figure 3 shows the gross distribution of project types within these example years of 1979, 1999 and 2006.

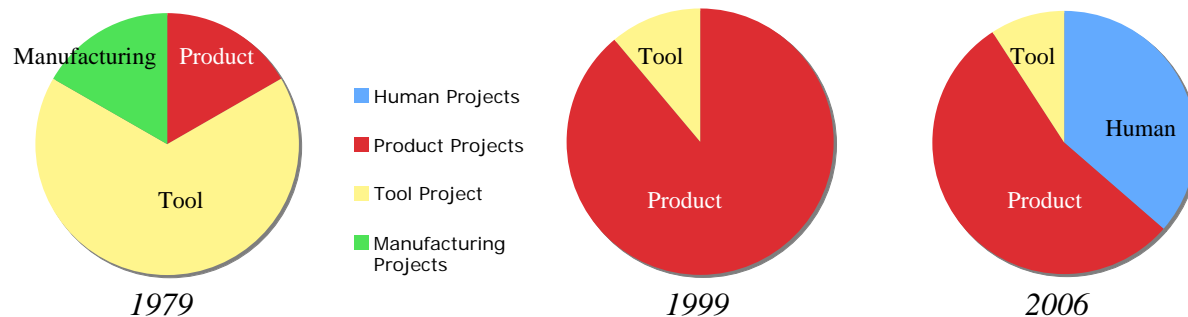


Figure 3 Distribution of Project Types by Percentage from 1979, 1999 and 2006 Example Years

## Conclusions and Next Steps

This survey classification of past projects is helpful to get at the gross trends over a number of years. It is instructive and informative to see patterns in the focus of project prompts from industry for student work.

Being more mindful of the evolving types of projects pursued is helpful. This is tempered by both an awareness and concern that established pedagogies for Manufacturing-focused projects is different than for Product-focused and user-centered Design-focused projects.

Questions arise too then about the student's steps through the design process. Is the process different for projects of different types and how so? The question is left unaddressed here. In this analysis where ME310 projects end up has been captured but the company prompt and where the student teams have taken the projects is not matched. The next step is to closely examine more complete records from sets of projects to understand the relationship.

It's useful to define and characterize such variables as the types of projects posed in courses like ME310 in order to be more explicit and reasonable about the expectations from the student, faculty and industry sponsor perspectives.

## Acknowledgements

This work was supported by the HPI-Stanford Design Thinking Research Program.

## Bibliography

1. Prince, MJ, RM Felder, "Inductive Teaching and Learning Methods: Definitions, Comparisons, and Research Bases," *Journal of Engineering Education*, April 1995, pp. 165-174.
2. Dutson, AJ, RH Todd, SP Magleby, CD Sorensen, RH Todd, "A Review of Literature on Teaching Engineering Design Through Project-Oriented Capstone Courses," *Journal of Engineering Education*, January 1997, pp. 17-28.
3. Ju, W, L Neeley, L Leifer, "Design, Design & Design; An overview of Stanford's Center for Design Research, Position paper for Workshop on Exploring Design as a Research Activity," CHI 2007, San Jose, California.
4. Simon, HA, *Models of Man: Social and Rational*. New York: Wiley. 1957.
5. Mabogunje, A, *Measuring Mechanical Design Process Performance: A Question Based Approach*, Doctoral Dissertation, Stanford University, 1997.
6. Lande, M and L Leifer. "Design Steps of Engineering Students Learning to Be Designers", American Society for Engineering Education Annual Conference, Austin, Texas, June 14-17, 2009. (in submission)
7. Stefik, M, and B Stefik, *Breakthrough: Stories and Strategies of Radical Innovation*: MIT Press, 2004.
8. Dym, C, Sheppard, S, Agogino, A, Leifer, L, Frey, D, Eris, O, "Engineering Design Thinking, Teaching, and Learning," *Journal of Engineering Education*, 2005.
9. Robinson, JA, "Engineering Thinking and Rhetoric," *Journal of Engineering Education*, 1998.
10. Cardella, ME, *Engineering Mathematics: an Investigation of Students' Mathematical Thinking from a Cognitive Engineering Perspective*, Thesis (Ph. D.) University of Washington, 2006.
11. Ishii, K, *Introduction to Design for Manufacturability (DFM) ME317 class notes*, Stanford University, 2005.
12. Saffo, P, "Six Rules for Effective Forecasting," *Harvard Business Review* Vol. 85, No. 7/8, 2007, pp. 122.

## **Learning Communities Improve Retention in Engineering and Computer Science**

Raman Menon Unnikrishnan and Ricardo V. Lopez  
College of Engineering and Computer Science  
California State University, Fullerton

### *Abstract*

As a comprehensive university, California State University, Fullerton (CSUF) serves approximately 37,000 students from a variety of cultures and backgrounds, with the recent increases tied to the immigrant population from Mexico as well as Central and South American countries. The majority of this surge has been from first-generation college students. The college, in an attempt to reverse its historical legacy for high student attrition, provides support and services that will help its diverse student population succeed academically and socially. The overall retention effort centers on a number of initiatives but this paper focuses on one such program, *The Engineering and Computer Science (ECS) Scholars Program* that is intended to create learning communities during the freshmen years. The *ECS Scholars* program is a learning community established in collaboration with Title V Retention Programs, the University Learning Center (ULC), the Center for Academic Support in Engineering and Computer Science (CASECS) and Freshmen Programs. The *ECS Scholars* program launched in the fall 2006 semester focuses on the academic success of *first-time freshman* (FTF) in engineering and computer science. While the ECS Scholars program is an at large initiative not aimed at any single community, its impact on underrepresented groups is found to be significant.

### *Introduction*

It is evident that the demographics of FTF entering four-year institutions of higher education in the United States is more diverse and multicultural than in previous decades.<sup>1</sup> While undergraduate enrollment has increased 21% from 1995 to 2005, the percentage of female enrollment has increased 27% in the same period. In addition, the percentage of minority college students has also increased. Minorities constituted 15% of the college population in 1976 but by 2005 that rose to 31%. In 2003 the Supreme Court of the United States recognized that sex and race, if used only as a subjective basis in acceptance decisions, bestows educational benefits that impact all members of an institution's student population.<sup>2</sup> Research shows that a diverse student population produces graduates capable of having complex points of views as well as enhanced capacity to take multiple perspectives into account.<sup>3</sup> Moreover, exposure to diversity allows greater cognitive insight and openness to enlist creative ideas from foreign cultures.<sup>4</sup> Modern engineers and computer scientists are expected to possess such skills in order to be successful in an increasingly globalized work force. Even though the need for diversity is well understood, statistics show a decreased enrollment of Women, Hispanics, and African-Americans in undergraduate engineering and computer science programs.<sup>5,6</sup>

Even when enrollment increases within these groups of FTF, thanks to aggressive recruitment efforts, retention and graduation rates remain relatively low.<sup>7</sup> Tinto argues that there

is no unilateral solution for this “revolving door” at institutions of higher education, but the adaptation of *learning communities (LC)* is a well corroborated educational solution.

### *Learning Communities*

In the simplest model of an LC a certain group of FTF participates in *block scheduling* i.e., register for the same classes that also meet at the same time.<sup>8</sup> In another form, students take classes with a larger groups of students unaffiliated to the LC, and then convene together in smaller discussion sections (Freshmen Interest Groups) facilitated by upperclassmen. More structured programs will congregate all students in one class that meets several times a week and conduct all instruction in one setting. Other settings combine facets of the aforementioned, and link students via a *first year seminar (FYS)* course. Joe Cuseo purports that FYS is “an integral part to success of all students, regardless of their level of academic preparedness.”<sup>9</sup> Some LCs also have a service-learning component, a pedagogical approach that interweaves faculty and student intellectual ingenuity to solve social problems.<sup>8</sup> Furthermore, LCs have three integral components: shared knowledge, shared knowing, and shared responsibility. Connecting courses so that they appear to be related promotes the networking of ideas and elevates thinking to a higher level (shared knowledge). Enrolling participants in the same classes induces social interaction and enhances intellectual interface, and allows students to care for the development of each other’s learning (shared knowing). Lastly, students who participate in LCs learn to become responsible for one another and become “mutually dependent” so that advancement is done as a cohesive unit with each member making contributions to the group (shared responsibility).

Learning communities have some key parts of the successful Treisman’s Model.<sup>10</sup> In the early 1980’s Uri Treisman created programs that enlisted African-American students to excel in mathematics rather than a program created solely to help them evade failure. Like LCs, Treisman’s emphasis is on collaborative learning among the students through the use of “small group teaching methods.” Students are not just expected to be remediated, but expectations are raised based on what Treiman observed to be the strength of some groups of students on his campus: *their ability to merge academic and social lives*. Treisman argued that it was also important to have faculty sponsorship in order to “nourish” the program and enable it to survive. The same requirement applies to LCs. In addition to faculty, Tinto also states that successful LCs must recruit the services of student affairs professionals since they are usually trained to teach linked courses.<sup>8</sup> Participation by both parties increases mutual appreciation between faculty and student affairs professional and enhances the services rendered to students in a coordinated manner.

In order to further corroborate the efficacy of LCs, Zhao and Kuh conducted a cross sectional study with the National Survey of Student Engagement (NSSE).<sup>11</sup> The validity of assessment of student participation in the NSSE is well established. The NSSEE specifically assesses: (a) possible link between student success and a particular learning community, (b) self-reported gains in the college experience and (c) overall satisfaction with the college experience. After sampling over 80,000 students across 365 four-year universities they found that participation in LCs is “uniformly and positively linked” with (a) academic performance, (b) engagement in worthwhile academic activities (faculty interaction, collaborative learning), (c)

increase college attendance and (d) general satisfaction with the college experience (personal and social development). Overall, they argue that learning communities significantly impact the educational and personal experience of FTF to a degree that persists throughout the undergraduate experience of that student.

The concept of learning communities as presented by the current literature is consistent with the needs of diverse undergraduate engineering and computer science students. Students in science majors are often stuck in a void while learning science and engineering.<sup>12</sup> This may occur because they are not meeting the cognitive levels expected by faculty, are not able to interpret mathematical models adequately, have English language literacy problems or simply were not exposed to the necessary prerequisite science knowledge in high school. The problem is augmented by the general lack of a refined pedagogical approach to science teaching in higher education as teaching is often centered on lecture style teacher-dominated approach. This approach lessens as students advance towards core content, but is pervasive in introductory courses for first year students. The same trend is true in engineering programs in higher education; students do not experience emphasis on cooperative teamwork (a key pedagogical approach in engineering education) until they reach higher level courses. Coll and Eames<sup>12</sup> support key factors that positively influence the efficacy of learning in engineering students, the influence of social interaction on a student's academic choices (student-to-student relationships), quality and nature of teacher-student relationship, quality of science instruction, quality of student-centered teaching, and incorporation of best teaching practices based on research.

Additionally, pedagogical solutions that seek to meet the needs of diverse engineering students should implement strategies that complement the typical steps they take when seeking help: first they reach out to fellow students for advice and then to their instructors, subsequently informal study groups and then finally formal learning services (tutoring centers, etc).<sup>13,14,15</sup> These approaches should also accommodate their preference for interactive approaches to learning, more interaction with instructors and tutors, practical classes and emphasis on cooperative teamwork. Cronje and Coll assert that interactive approaches to learning enhances better comprehension of basic engineering skills, the appreciation for science, and an appreciation for the type of work conducted by a professional engineering or scientist. Similarly, successful computer science programs must provide a three dimensional perspective of potential careers in computer science.<sup>6</sup> Fisher and Margolis assert that an environment must be created where these perspectives are "valued and respected." Four year institutions can apply a social context to computer science education by: interconnecting other disciplines to computer science, an emphasis on the interaction between humans and computers and a component that encourages the application of computer science skills to community issues. They recommend that the program should also address the self confidence issues of students.

### *Current Situation*

The overall fall 2006 ECS FTF class had a 1-year retention rate of 49% whereas overall fall 2007 ECS FTF class had a 1-year retention rate of 53% showing a slight improvement. The overall fall 2006 ECS cohort had a 2-year retention rate of only 31%. These are appalling statistics.

### *Description of the ECS Scholars Learning Community*

The ECS scholars LC has been in existence since 2006. Students participate in this program only during the fall and spring semesters of their first year; they are not provided intervention after their first year at CSUF. The program is currently sponsoring its third cohort. The ECS Scholars LC is designed for FTF majoring in engineering or computer science aimed at reversing the unacceptably large attrition during the first year. ECS Scholars experience a smooth transition to college life by maximizing campus resources, opportunities for individual and community development, and on-going interaction with faculty, student affairs professionals, and peers from the College of ECS.

The ECS Scholars LC offers rewarding and unique benefits centered on the following aspects:

- Develop friendships and connections with students and faculty within the College of ECS. Students are block scheduled and placed in a FYS course each semester of their first year (1 unit in the fall and 2 in the spring semester) with an instructor with a PhD in Engineering or Computer Science.
- Receive specialized academic advisement for general education and major coursework under the guidance of CASECS and a graduate-student academic advisor.
- Learn how to study for core math, science, engineering and computer science courses in specialized Freshmen Interest Groups lead by upperclassmen.
- Receive intensive tutoring and academic assistance in core classes on a one-on-one basis
- Opportunities for service-learning experience related to their field of interest; students must complete 20 hours at government or non-profit organizations.
- Receive counseling on transitional issues from a student affairs professional, a co-instructor in both sections of the FYS courses.

The ECS Scholars Program started in 2006 with the following program goals and objectives (the same goals persist each year):

Goal: The first academic year fall-to-fall persistence of 75 first-time-freshman students in the College of Engineering and Computer Science will be 80% as well as 80% of the cohort will maintain adequate academic standing at the end of their first academic year.

Objective 1.1 The 75 students who participate will attend a block of classes in fall 2006 and spring 2007.

Objective 1.2 Participants will attend study groups that cover study techniques and strategies, as well as course content that support the blocked classes.

Objective 1.3 Participants will have access to at least three hours each week of individual tutoring.

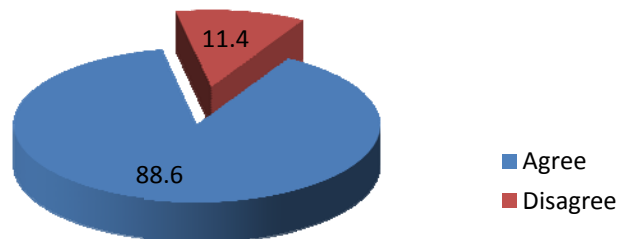
Objective 1.4 Participants will be assigned a peer advisor in the College of Engineering and Computer Science.

Objective 1.5 Participants will be required to meet with the CASECS academic counselor at least once each semester.

As mentioned before, the ECS scholars program is supported by CASECS. This center provides a learning environment for all students in ECS regardless of their year in school. Upon

entering the ECS scholars program students are automatically CASECS members. CASECS students receive priority registration for courses, space for student-to-student collaborative learning among all grade levels, and academic counseling; these features aid members of the ECS Scholars program. Another key partner is Freshmen Programs of CSUF. Freshmen programs joined the ECS Scholar support team after the first year of the program (2007 cohort). Freshmen programs facilitates the following for the ECS scholars program: (1) one unit (UNIV 100A) FYS course for ECS Scholar students in the Fall semester, a class that is vital to academic planning, orientation, and transition to Cal State Fullerton, (2) a two unit (UNIV 100B) course in the Spring semester that offers further integration into areas of Engineering and Computer Science via the Service Learning component, (3) maintenance of registration planners that direct students into blocked-scheduled sections linked to their UNIV 100 LC (they work with departments to select appropriate courses, coordinate scheduling for the FYS courses), (4) a graduate-student academic advisor to help ECS Scholars understand the university registration system, coordinate major and general education requirements, and resolve other problems that may prevent successful registration, (5) assistance with implementation of mid semester grade check (early intervention) and connect students academically at-risk with resources to help them succeed in their classes, (6) professional development for instructors and student affairs professionals, and (7) assessment of all professional development programs as well as peer evaluations for all instructional team members.

A third partner in the ECS Scholars program (a partner since the inception of the program) is the ULC. The mission of ULC is to provide all CSUF students with academic support in an inviting and contemporary environment. The staff members of the ULC are carefully selected and trained to assist students with their academic assignments, general study skills, and computer user needs. The ULC provides the ECS Scholars with: Freshmen Interest Groups (provide collaborative learning groups across disciplines) led by trained upperclassmen, one-to-one tutoring, academic workshops, and online writing tutoring. Through the ULC's continual training of Study Group Leaders and a deeper partnership with ECS, a solid foundation of success has been laid for all ECS students served. ULC tutors have a positive impact on the ESC scholars they served in 2006 (n=19) as indicated by the 88.6% overall satisfaction rating indicated in Figure 1.

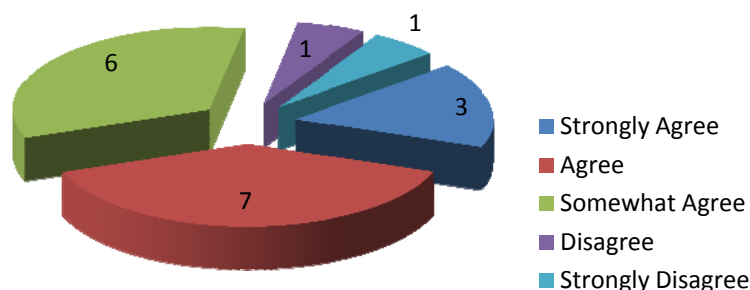


**Figure 1: 88.6% of all ECS Scholars were satisfied with the knowledge they received, courteousness of the tutors, and the tutors ability to create group discussion.**

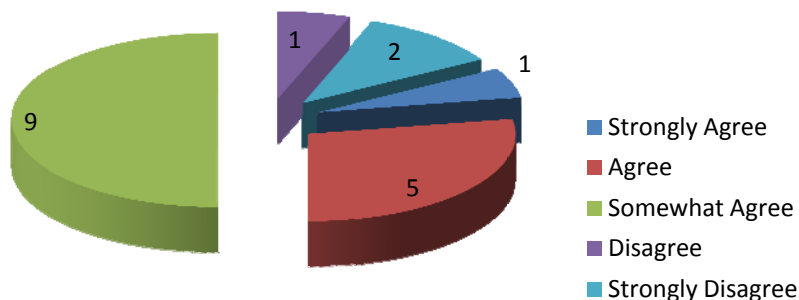


ULC tutors participate in training throughout their employment. Issues of cultural sensitivity, conflict resolution, and cutting edge tutoring techniques are taught through the Peer Tutoring Certification process. These results can be immediately seen in the evaluation responses of the students that receive the ULC’s services. As shown in Figure 2, great pride is taken in meeting the needs of CSUF’s students in a friendly and courteous manner.

In the collaborative process of tutoring, it is important for ULC group leaders to create a dialogue with students that enable them to actively participate in their individual education. As part of the Peer Tutoring Certification, tutors learn to ask engaging questions that challenge and stimulate independent thinking. Figure 3 shows that 83.3% of ECS scholars surveyed, felt their Study Group Leader successfully facilitated group discussion.

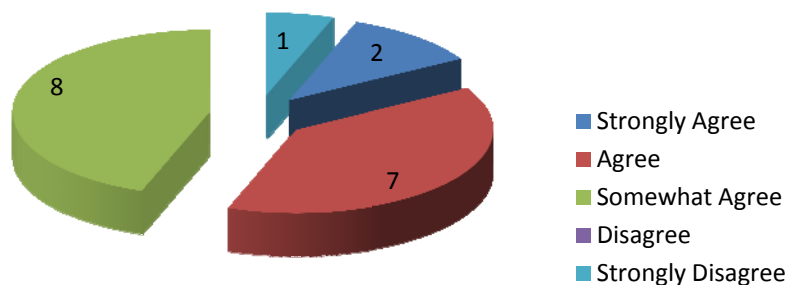


**Figure 2: Of the 18 ECS Students surveyed 88.9% agreed their Study Group Leader was helpful and friendly.**



**Figure 3: 83.3% of ECS students surveyed somewhat agreed, agreed, strongly agreed that their study group leader successfully facilitated group discussion.**

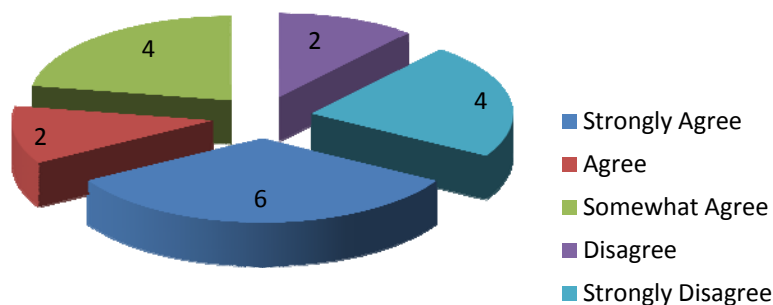
The ULC’s Study Group Leaders are very knowledgeable about the subjects tutored. Only students that demonstrate excellent writing skills and have an exemplary academic track record are hired as learning assistants. Tutors are also personable and able to explain complex concepts in simple terms. This results in 94.4% of the students served reporting an increase in knowledge of the subject area they studied, as shown in Figure 4.



**Figure 4: 94.4% of students surveyed somewhat agreed, agreed or strongly agreed that their study group leader aided in personal increase of knowledge in the subject area.**

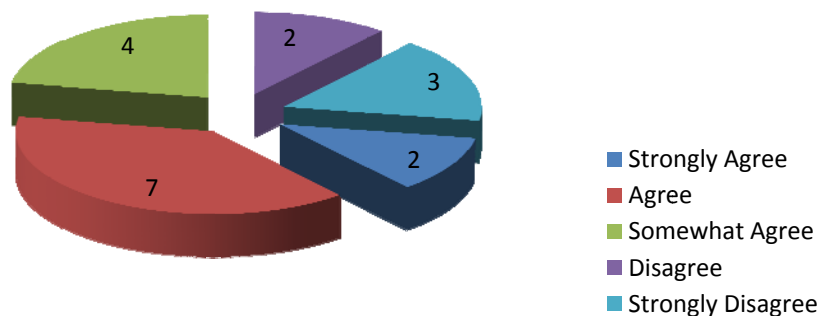
*Attendance and Perceived Preparedness for Study Groups*

The ULC hopes to strengthen collaboration with ECS to increase student participation in study groups. The results displayed above clearly indicate that the ULC provides an invaluable resource that supports academic participation and success. As Figure 5 illustrates, 55.5% of students surveyed did not regularly attend study groups. In order to make the most of this resource, future goals to improve regular attendance to study groups have been established. As the partnership between ECS and the ULC progresses, greater regular participation in study groups will result in a richer academic experience for ECS students.



**Figure 5: Fifty-five percent (55.5%) of students stated that they had not attended study groups regularly when asked if they attended study groups.**

Future efforts will focus on encouraging proper study skills. Figure 6 indicates that only 50% of students come prepared for study group. To rectify this, Study Group Leaders will not only give an overview of the subject area, but will help students learn what types of questions to ask as they are reading and engaging the study material. This approach will encourage individual participation in study outside of the classroom and study group atmosphere.



**Figure 6: Fifty (50%) of students admitted that they did not come to study group prepared on a regular basis when asked if they prepared for the study groups.**

The distribution of ECS students in the fall semesters of 2006 and 2007 are given in Table 1. This table shows the different categories of the overall student population as well as those who were part of the ECS scholars program. Note that the overall enrollment in the college as well as participation in the ECS Scholars program increased from 2006 to 2007.

**Table 1: Student categories in Fall 2006 and Fall 2007**

**ECS Fall 2006 FTF**

	Native American	Asian	African American	Hispanic	White	Nonresident	Unknown	Total
Men	3	77	35	131	87	17	21	371
Women	0	28	8	25	26	1	5	93
Total	3	105	43	156	113	18	26	464

**Fall 2006 ECS LC**

	Native American	Asian	African American	Hispanic	White	Nonresident	Unknown	Total
Men	0	0	1	12	0	3	0	16
Women	0	1	0	2	0	0	0	3
Total	0	1	1	14	0	3	0	19

**ECS Fall 2007 FTF**

	Native American	Asian	African American	Hispanic	White	Nonresident	Unknown	Total
Men	4	82	28	142	82	33	21	392
Women	1	17	9	26	27	3	4	87
Total	5	99	37	168	109	36	25	479

### Fall 2007 ECS LC

	Native American	Asian	African American	Hispanic	White	Nonresident	Unknown	Total
Men	1	8	2	16	5	2	4	38
Women	0	1	1	2	4	0	0	8
Total	1	9	3	18	9	2	4	46

Note: "Nonresident" implies non-citizen

#### *Academic Impact of ECS Scholars Program*

The pass rate in various freshmen courses for ECS Scholars is significantly higher than the general pass rate for ECS students. Table 2 demonstrates the passing rates of ECS relevant courses taken by the 2006 LC in Fall 2006 and Spring 2007. Pass rates are compared with pass rates of all FTF in 2006. Table 3 demonstrates the passing rates of ECS relevant courses taken by the 2007 LC in Fall 2007 and Spring 2008. Pass rates of those the 2007 cohort were compared between those that attended the study groups and those that did not attend the study group.

#### *ECS Scholar's Retention in the College of ECS*

The 2006 Fall LC of the ECS Scholars program had a one year retention rate of 79% as opposed to 49% for the overall ECS FTF the same year. The Fall 2007 LC had higher one-year

**Table 2: Pass rate of the 2006 ECS Scholars LC in important courses**

Fall 2006		
Course Name	% Passed in LC	% Passed of FTF
Math 125 Pre Calculus	90.00 (n=10)	48.65 (n=37)
Math 150A Calculus I	90.00 (n=10)	50.00 (n=8)
Math 150B Calculus 2	100.00 (n=0)	0.00 (n=3)
Math 270A Mathematical Structures I	100.00 (n=1)	100.00(n=2)
<i>Fall 2006-All Mathematics Combined</i>	<i>90.48</i>	<i>48.00</i>
Spring 2007		
Math 125 Pre Calculus	50.00 (n=2)	52.17 (n=23)
Math 150A Calculus I	75.00 (n=8)	56.25 (n=16)
Math 150B Calculus 2	33.30 (n=6)	83.33 (n=6)
Math 270A Mathematical Structures I	100.00 (n=1)	75.00 (n=4)
Math 270B Mathematical Structures II	100.00 (n=1)	100.00 (n=1)
<i>Spring 2007-All Mathematics combined</i>	<i>61.00</i>	<i>60.00</i>

retention rate of 80% (slightly higher than the first cohort) whereas the overall Fall 2007 FTF had a one-year retention rate of only 53% the same year. The fall 2006 LC had a two-year retention rate of 42%, whereas the overall fall 2006 ECS FTF had a two-year retention rate of

only 31%. The 2007 LC has not reached their second year in ECS and one-year retention data of the 2008 LC will be assessed at the end of the Spring 2009 semester. The term “Retention” is defined as in “ECS retention”, including only those who still major in ECS and excluding those who moved to other programs at CSUF.

**Table 3: Pass rate of the 2006 ECS Scholars LC in important courses**

Fall 2007		
Course Name	% Passed that attended study groups	% Passed that did not attend study groups
Math 125 Pre Calculus	65.38 (n=26)	28.57 (n=14)
Math 150A Calculus I	100.00 (n=13)	50.00 (n=2)
EGCE Engineering Surveying	75.00 (n=8)	50.00 (n=8)
EGME 102 Graphical Communications	100.00 (n=4)	66.67 (n=3)
Spring 2008		
Math 150A Calculus I	100.00 (n=9)	80.00 (n=5)
Math 270A Mathematical Structures I	75.00 (n=4)	80.00 (n=5)
CPSC 120 Intro. to Programming	100.00 (n=2)	00.00 (n=0)
CPSC 121 Programming Concepts	77.78 (n=9)	33.33 (n=3)
EGCE 206 Computer Aided Drafting	100.00 (n=4)	100.00 (n=9)
EGEE 245 Com. Logic and Architecture	100.00 (n=2)	00.00 (n=0)
EGME 245 Laboratory	100.00 (n=2)	00.00 (n=0)

### Conclusion

The ECS Scholars program contains the integral parts of a structured LC: 1) block scheduling, 2) incorporation of Freshmen Seminar Groups, 3) Service Learning Component and 4) collaboration between faculty and student affairs professionals.<sup>8</sup> The program allows students to take advantage of interpersonal interactions that usually take place in upper level courses or may otherwise not occur without such a program. ECS Scholars participate in shared knowledge and the FYS course covers a wide range of topics that spark the interest of students in different areas of Engineering and Computer Science.<sup>9</sup> The program fulfills the Triesman’s model: the merging of student’s academic and social lives (as facilitated by Freshmen Interest Groups and CASECS).<sup>8,10</sup> By the end of the first semester students form formal friendships and depend on one another for academic support (shared responsibility) and thereby fortify the student-to-student relationship that enhances the educational experience of engineering students.<sup>8,12</sup>

The ECS Scholars Program also caters to the needs of Computer Science students.<sup>6</sup> The FYS courses’ curriculum emphasizes the interdisciplinary application of Computer Science with career presentations by career specialist and alumni of the college. The service learning component allows the application of computer science skills to community issues. Students are given a three dimensional perspective on multiple careers in computer science via exposure to computer science oriented student clubs, access to computer science faculty, and invitation to

multiple career fairs. In addition, the one-on-one advisement sessions with the student affairs professional enhances the self confidence of the student.

Above all, the first two cohorts of the ECS Scholars program have closely achieved the projected a one year retention rate of 80% (79% for the 2006 cohort and 80% for the 2007 cohort). Participation in study groups needs to improve, but students who attend are benefiting both academically and socially. In addition to the Freshmen Interest groups, the students also had access to over three hours of one-on-one tutoring. Participants met regularly with a CASECS academic counselor and the graduate-student academic advisor provided by Freshmen Programs. Overall, students in the LC had better passing rates compared to those that were not in the LC. Although no statistically significant inferences can be made, the effectiveness of Freshmen Seminar Sessions is seen when comparing pass rates of LC students who consistently attended the sessions versus those that did not. The 2006 and 2007 cohorts had access to peer mentors in the FYS courses and the 2008 cohort had access to them outside of class. The ULC continually provides the leaders of the Freshmen Interest Groups with training and supplemental instruction will be incorporated to increase efficiency and attendance. Students are taught how to efficiently prepare for study group sessions in the FYS courses and by the Freshmen Interest Group Leaders. The services rendered by the student affairs professional were also critical in helping students deal with transitional issues.

Overall, the ECS Scholars program has been an unqualified success in retaining student in the College of Engineering and Computer Science. The Title V grant that funds this successful initiative is ending in the middle of CY 2009. While it is hoped that the funding will continue, some aspects of the program such as block scheduling will continue regardless of funding.

#### *Acknowledgments*

This paper is dedicated to the memory of Dr. Donald Castro for his enlightened vision on the educational mission of the university and his unwavering support to the issues of retention of underrepresented students. His untimely passing has created a void for all those who knew him. The authors would also like to thank Dr. Hye Sun Moon, Senior Research Analyst at the Institutional Research and Analytical Studies Department, Fran Zareh-Smith, Director, University Learning Center and Dr. Nancy Page-Fernandez, Director, Freshmen Programs (all at CSUF) for their contributions and support.

#### *References*

1. U.S. Department of Education, National Center for Education Statistics. (2008). *Digest of Education Statistics, 2007* (NCES 2008-022). Retrieved February 6, 2008 from <http://nces.ed.gov/fastfacts/display.asp?id=98>
2. Grutter v. Bollinger (2003). Supreme Court of the United States.
3. Gottfredson, N., Panter, A., Daye, C., Allen, W., Wightman, L., & Meera, D. (2008). Does diversity at higher education institutions influence student outcomes? *Journal of Diversity in Higher Education, 1* (2), 80-94.
4. Leung, A., Maddux, W., Galinsky, A., & Chiu, E. (2008). Multicultural experience enhances creativity, *American Psychologists Association, 63* (3), 169-181.

5. Watson, K., & Froyd, K. (2007) Diversifying the U.S. engineering workforce: A new model, *Journal of Engineering Education*, 96, 19-32.
6. Fisher, A., & Margolis, A. (2002). Unlocking the clubhouse: the Carnegie Mellon experience, *SIGCSE Bulletin*, 34 (2), 79-83.
7. Tinto, V. (2008, August). When access is not enough, Carnegie Perspectives. Message posted to <http://www.carnegiefoundation.org/perspectives/sub.asp?key=245&subkey=2626>
8. Tinto, V. (2003) Learning better together: The impact of learning communities on student success in higher education (White Paper). Retrieved from <http://www.maine.edu/system/asa/vincenttinto.php>
9. Cuseo, J. (2008) Academic credit (White Paper). Retrieved from <http://www.uwc.edu/administration/academic-affairs/esfy/cuseo/>
10. McNeilly, J. (2007). Merit workshop: Treisman's Model (White Paper) Retrieve from <http://www.math.uiuc.edu/MeritWorkshop/uriModel.html>
11. Zhao, C., & Kuh, G. (2004). Adding value: Learning communities and student engagement, *Research in Higher Education*, 45 (2), 115-138.
12. Coll, R., & Eames, C. (2008). Developing an understanding of higher education science and engineering learning communities, *Research in Science & Technological Education*, 26 (3), 245-257.
13. Cronje, T., & Coll, R. (2008). Student perceptions of higher education science and engineering leaning communities, *Research in Science & Technological Education* 26 (3), 295-309
14. Shapiro, S., & Levine, H. (1999). Creating learning communities: A practical guide to winning support, organizing for change, and implementing programs. San Francisco: Jossey-Bass.
15. Unnikrishnan, R., & Garcia, G. (Eds). (2007) Proceedings from the Fifth International Latin American and Caribbean Conference for Engineering and Technology'07 (*LACCEI: Enhancing Engineering and Computer Science Education for a Diverse Community*). Tampico, México.

#### *Biographical Information*

**Raman Menon Unnikrishnan** is the Dean of the College of Engineering and Computer Science at California State University, Fullerton. He is active in teaching and research in the areas of Control Systems, Power Electronics and Signal Processing. He has been a consultant to several industries and governmental agencies, and has been involved in technical and professional education for industries. He is active nationally and internationally in the field of engineering education and engineering accreditation.

Prior to joining CSUF in 2001, Dr. Unnikrishnan was on the faculty of the Rochester Institute of Technology in Rochester, NY where he also served as Associate Dean for Graduate Studies and Research from 1989 to 1991 and as the Head of the Electrical Engineering Department from 1991 to 2001. He received his BSEE degree from the University of Kerala in India, MSEE degree from South Dakota State University and the Ph.D. degree in electrical engineering from the University of Missouri-Columbia. He is the recipient of the *Eisenhart Award for Excellence in Teaching* at RIT, a special professionalism award from the Xerox Corporation and an IEEE Region 1 *Award for Leadership* on advancing the continuing education needs of the engineering community. In 2000, he received the *IEEE Third Millennium Award* for Outstanding Achievements and Contributions. In 2006 he received the *Missouri Honor Award* for being an outstanding alumnus. Since 2008 he has been a Commissioner of the Engineering Accreditation Commission of ABET. Dr. Unnikrishnan is a Fellow of IEEE.

**Ricardo V. Lopez** is the Retention Coordinator for the College of Engineering and Computer Science at CSUF. He helps coordinate the collaborative management of the ECS scholars program as well as directs several retention efforts aimed at helping ECS first-time freshmen. He has worked in the field of education for over 5 years with various non-profit organizations and several Southern California school districts. He is also actively involved in the field of Public Health research and advocacy. In 2006 he was accepted into the Minority Training Program in Cancer Control Research (MTPCCR) at UCLA where he conducted research at the Jonson Comprehensive Cancer Center. He earned his undergraduate degree at UCLA in Molecular, Cell and Developmental Biology and his Master of Public Health at CSUF. He is the lead author of published manuscripts on the knowledge and perception of Human Papilloma virus and Cervical Cancer among college-age students.

# Using Tablet PCs to Enhance Student Performance in an Introductory Circuits Course

Amelito G. Enriquez  
Cañada College  
Redwood City, CA

## Abstract

Tablet PCs have the potential to change the dynamics of classroom interaction through wireless communication coupled with pen-based computing technology that is suited for analyzing and solving engineering problems. This study focuses on how Tablet PCs and wireless technology can be used during classroom instruction to create an Interactive Learning Network (ILN) that is designed to enhance the instructor's ability to solicit active participation from all students during lectures, to conduct immediate and meaningful assessment of student learning, and to provide needed real-time feedback and assistance to maximize student learning. This interactive classroom environment is created using wireless Tablet PCs and a software application, NetSupport School. Results from two separate controlled studies of the implementation of this model of teaching and learning in sophomore-level Introductory Circuit Analysis course show a statistically significant positive impact on student performance. Additionally, results of student surveys show overwhelmingly positive student perception of the effects of this classroom environment on their learning experience. These results indicate that the interactive classroom environment developed using wireless Tablet PCs has the potential to be a more effective teaching pedagogy in problem-solving intensive courses compared to traditional instructor-centered teaching environments.

## 1. Introduction

Studies have long shown that the traditional instructor-centered lecture format is an ineffective learning environment, and that active participation, as well as interactive and collaborative teaching and learning methods, are more effective in various areas of science and engineering education including Chemistry<sup>1</sup>, Physics<sup>2</sup>, Engineering<sup>3</sup>, and Computer Science<sup>4</sup>. Various uses of technology have been found to be effective in enhancing the classroom experience to achieve more interactive and collaborative environments. These techniques include handheld wireless transmitters in Personal Response Systems (PRS)<sup>5</sup>, various forms of computer-mediated collaborative problem solving<sup>6</sup>, and the use of wireless Tablet PC technology<sup>7,8</sup>.

Tablet PCs are essentially laptop computers that have the added functionality of simulating paper and pencil by allowing the user to use a stylus and write directly on the computer screen to create electronic documents that can be easily edited using traditional computer applications. This functionality makes Tablet PCs more suitable than laptop computers in solving and analyzing problems that require sketches, diagrams, and mathematical formulas. Combined with wireless networking technology, Tablet PCs have the potential to provide an ideal venue for applying previously proven collaborative teaching and learning techniques commonly used in smaller engineering laboratory and discussion sessions to a larger, more traditional lecture setting.



Currently, the range of use of Tablet PCs in the classroom includes enhancing lecture presentations<sup>8,9</sup>, digital ink and note taking<sup>10</sup>, E-Books (books in electronic format) that allow hyperlinks and annotations<sup>11</sup>, Tablet-PC-based in-class assessments<sup>8,9</sup>, and Tablet-PC-based classroom collaboration systems such as the Classroom Presenter<sup>12</sup>, and the Ubiquitous Presenter<sup>13</sup> that can enhance student learning and engagement. As the use of Tablet PCs in the classroom grows, there is a growing need to understand how these various uses and applications can facilitate and enhance student learning.

This paper summarizes the results of a series of studies on how Tablet PCs and wireless technology can be used during classroom instruction to create a model that is highly interactive. In this paper, this model will be referred to as an Interactive Learning Network (ILN). The Interactive Learning Network (ILN) is designed to enhance the instructor's ability to solicit active participation from all students during lectures, to conduct immediate and meaningful assessment of student learning, and to provide needed real-time feedback and assistance to maximize student learning. This interactive classroom environment is created using wirelessly networked Tablet PCs and a software application, NetSupport School, that allows various levels of interactions between the instructor and the students during lectures. In this model of instruction, less time is spent by the instructor delivering content through traditional instructor-centered lectures. The lectures focus on introducing new concepts and applying them to a few simple examples with more complex examples given as guided exercises. Students can access the instructor's presentation and add their own annotations using Windows Journal or PowerPoint. Throughout the lecture, the NetSupport School software allows the instructor to quickly assess individual student understanding of concepts using instant student surveys. At the end of each lecture, more involved examples are introduced as exercises that students work on individually or in groups on their Tablet PCs using Windows Journal and/or other appropriate software (Excel, Matlab, MultiSIM, PSPICE, etc.). While students work on more challenging problems, the instructor has the capability to scan and monitor students' work from the instructor's tablet PC, and guide the students and assess their progress through NetSupport's Survey mode using a series of short, previously prepared leading questions. Individual student questions are received through the Help Request feature, and individual assistance can be provided using the Monitor, Share, and Control features. The instructor is also able to effectively manage the various interactions through group chat, electronic whiteboard, and file transfer and distribution. The effectiveness of this model comes from the ability of the instructor to monitor and interact with individual students while they analyze problems on the computer using an input device that allows them to write and manipulate formulas, and make sketches and diagrams.

This paper will address the effects of these technology-enhanced interactions and collaborations on student performance, on student attitude towards the ILN model of instruction and the use of Tablet PCs in the classroom. Results of these studies will show that compared to courses taught with a traditional instructor-centered mode, the Interactive Learning Network can lead to: (1) better student performance in the courses where the technology is implemented, as indicated by better student grades on homework, quizzes, and tests compared to courses that do not use the technology, (2) better retention of prior prerequisite knowledge of basic concepts and their applications for students in the interactive class, and (3) positive attitude towards the use of the ILN model of instruction, and towards student use of Tablet PCs in the classroom.

## 2. Methodology

To determine the effects of the Tablet PC-enhanced interactive classroom on student learning in an Introductory Circuits Analysis course, two case studies each comparing an ILN-based class environment with a traditional instructor-centered class.

### 2.1. The Circuits Class at Cañada College

Cañada College is part of the 108-school California Community College system, and is one of the smallest community colleges in the San Francisco Bay Area with approximately 6,000 students. The college is a federally-designated Hispanic Serving Institution with approximately 42 percent Latino students. Cañada's Engineering Department is a two-year transfer program with approximately fifteen to twenty students transferring to a four-year institution every year. The Circuits course at Cañada College is a three-unit, sophomore-level lecture course required of all engineering students regardless of their majors, or their transfer institutions. The class meets for three hours a week for sixteen weeks, and covers topics on theory and techniques of circuit analysis, circuit laws and nomenclature, resistive circuits, controlled sources, ideal operational amplifiers, natural and complete responses of first- and second-order circuits, steady-state sinusoidal analysis, power calculations, transformers, and three-phase circuits. In the traditional instructor-centered approach to teaching the class, the instructor presents new concepts, derives important equations related to the concepts, and then presents a collection of illustrative sample problems that are solved by the instructor in detail. Additional examples are given as in-class exercises, or assigned as homework problems. Periodic assessment of student learning is done in the form of quizzes and tests given during the duration of the semester. Success in this course using this approach has been limited, as Circuits has traditionally been an engineering course that has high attrition rates.

### 2.2. The Two Case Studies

To study the impact of the Interactive Learning Network model of instruction, two case studies were done: Study 1 involved comparing two Cañada College Circuits courses, the Spring 2006 class that used the ILN model, and the Spring 2005 class that used the traditional instructor-centered model. Study 2 involved comparing two Circuits courses from two different institutions in the Spring 2006 semester, a class at Cañada College that used the ILN model, and a class at San Francisco State University that used the traditional model.

*Study 1: Cañada College Spring 2006 and Spring 2005.* The Interactive Learning Network was first implemented in a Circuits class of 41 students at Cañada College in Spring 2006. Since Cañada College offers only one section of this class every Spring semester, a comparison group could not be established for the study. Instead, the performance of the Spring 2006 experimental group that used the ILN model was compared with that of the Spring 2005 Circuits class of 28 students. Similar homework, quizzes, and exams were given to both Circuits classes. An attitudinal survey was also administered at the end of the Spring 2006 semester to evaluate students' opinion of the use of the ILN model and Tablet PCs in the classroom.

A comparison of student demographics for the two Circuits classes in this part of the study shows them to be very similar. The Spring 2006 class (ILN model) with 41 students, and the Spring 2005 (non-ILN) class started with 28 students. For both years, the majority of the students were male, and over 40% of the students were Mechanical Engineering majors. For both years, the ethnic distribution was diverse, with no majority ethnic group.

*Study 2: Spring 2007 Circuits at Cañada College and San Francisco State University.* For Spring 2007, two sections of Circuits courses were studied, one at Cañada College and one at San Francisco State University (SFSU), with both classes taught by the same instructor. As noted above, Cañada College offers only one section of Circuits every spring semester. To study the impact of the ILN model on student performance in the Circuits class at Cañada College, the Circuits class at San Francisco State University was selected to be the comparison group. In both courses, the instructor used a Tablet PC and a combination of PowerPoint and Windows Journal presentations to deliver lectures. The only major difference between the two classes was the student use of Tablet PCs and NetSupport School in the Cañada College class to create the Interactive Learning Network. Students in the Cañada class use Tablet PCs to take notes, to analyze and solve problems, and to interact with the instructor through NetSupport School software's Instant Survey, Electronic Whiteboard, Chat and Help Request features.

The Circuits course at SFSU was a three-unit lecture course that met three hours a week for fifteen weeks, one week shorter than Cañada's sixteen-week course. The first fifteen weeks of the Cañada class covered topics that were identical to SFSU's topics. For the last week the Cañada class covered a topic that was not covered at SFSU and not included in any of the tests. The last homework set at Cañada was not included in the analysis and comparison of the performance of the two groups.

A comparison of the student demographics was done for the two groups of students for Study 2, with 16 students in the Cañada class, and 46 in SFSU. Both groups of students were ethnically diverse, with Hispanics as the biggest group at Cañada and Asians as the biggest at SFSU. At SFSU, 50% were Civil Engineering majors while the students at Cañada were more evenly distributed among the different majors (Civil, Computer, Electrical, and Mechanical). With respect to gender, the Cañada group had a slightly lower percentage of female students (12.5% vs. 17.4%).

Due to the inherent differences between the two groups of students in Study 2 (Cañada College being a community college, and SFSU being a university), a diagnostic test was given to the both groups to ascertain whether the students' levels of preparation for the class were comparable. The diagnostic test consisted of fifteen multiple-choice questions measuring student knowledge of electric circuits concepts and their applications. These questions involved topics that were covered in the prerequisite Physics course. Results of this diagnostic test showed no statistically significant difference in the average and median scores of the two student groups.

### 2.3. Classroom Formats

Table 1 summarizes the similarities and differences in the classroom structure of the experimental and comparison groups of the two case studies. All four of the courses in the studies were taught by the same instructor. For the two experimental groups that used the ILN model, each student was given a Tablet PC to use during lectures, and interactivity during delivery of new topics was achieved using NetSupport's Instant Survey and electronic whiteboard features that allow participation from all students. As previously described, most of the illustrative examples were given as exercises that students solved using the Tablet PCs while the instructor observed and guided their progress, and provided individual assistance through the NetSupport School software. For the comparison, non-ILN groups, the class structure was instructor-centered and non-interactive both during the introduction of new topics and solutions of illustrative examples.

The last row of Table 1 shows that for three of the four groups (2006 Cañada, 2007 Cañada, and 2007 SFSU) the instructor used the same method in generating and delivering lecture notes to the students. For these three groups, the instructor used a Tablet PC in combination with PowerPoint and Windows Journal to deliver class material. The Tablet PC replaced the blackboard and chalk (or whiteboard and pen), making it possible to have an electronic record of all the lecture notes prepared before and during class. An outline of the day's lecture was usually prepared using a combination of PowerPoint and Windows Journal presentations. During lectures, the instructor added and saved handwritten annotations, sketches, derivations, illustrative problems, and problem solutions to the lecture notes that were then posted on the class website. This allowed subject material to be covered more efficiently and adjustment of the class agenda to be done more easily to accommodate student progress. For the non-ILN Spring 2005 Cañada group, the traditional chalk and blackboard was the main medium for generating and delivering lecture notes.

**Table 1.** Comparison of classroom formats for the experimental and comparison groups of Study 1 and Study 2.

Classroom Format	Study 1		Study 2	
	Experimental Cañada 2006 (ILN)	Comparison Cañada 2005 (non-ILN)	Experimental Cañada 2007 (ILN)	Comparison SFSU 2007 (non-ILN)
Student Use Tablets	Yes	No	Yes	No
Lecture Delivery of New Material	Interactive with Students using NetSupport	Not Interactive	Interactive with Students using NetSupport	Not Interactive
Presentation of Illustrative Sample Problems	Interactive with Students using NetSupport	Not Interactive	Interactive with Students using NetSupport	Not Interactive
Instructor Lecture Notes	Tablet PC	Blackboard and Chalk	Tablet PC	Tablet PC

## 2.4. Data Analysis

To measure the impact of the Interactive Learning Network on learning, the performance of the ILN and non-ILN groups for each of the two case studies were compared. For each case study, scores of the two groups of students on fifteen homework sets, four quizzes, four tests, and a final examination were compared. Identical homework problems were assigned from the textbook for the ILN and non-ILN groups within the same case study (Study 1 or Study 2). The average scores for the experimental and comparison groups were computed and independent Student *t*-tests were used to evaluate the statistical significance of the results.

For Study 2 consisting of Cañada 2007 and SFSU 2007 classes, an additional pre- and post-tests performance comparison was done. The Diagnostic Test given in the first week of the semester was again given a week before the final exam as the post test. The average scores for the experimental and comparison groups were computed and independent Student *t*-tests were used to evaluate the statistical significance of the results.

To determine students' attitudes towards the use of Tablet PCs and the Interactive Learning Network model of class instruction, an attitudinal survey was given to the two experimental groups at the end of the semester. This survey has two parts: one on NetSupport School use and one on student use of Tablet PCs. It was designed to determine students' perceptions of the impact of the ILN model on student learning and teaching effectiveness. Simple averages of student responses were computed to summarize the results.

## 3. Results

### 3.1. Study 1: Cañada College Spring 2006 and Spring 2005

In this section, performance of the two groups of students, Spring 2006 class with ILN format and the Spring 2005 class with a traditional format, will be compared. Additionally, results of the attitudinal survey on student perception of and satisfaction with the ILN model of instruction and the use of Tablet PCs will be presented.

*Class performance comparison.* A summary of the comparison of the performances of the two groups of Circuits students is shown in Table 2. Quiz Average is the average of four quizzes, Homework Average is the average of fifteen homework sets, and Test Average is the average of four tests. The last column of Table 2 is the difference between the average scores received by Spring 2006 students and Spring 2005 students. There is a significant difference between 2006 and 2005 results in Homework Average [ $t(1,42) = 2.61, p < .01$ ] and Quiz Average [ $t(1,33) = 8.06, p < .001$ ]. Although the average of the four tests from the two groups have no statistically significant differences, two of the four have statistically significant differences – Test 3 [ $t(1,54) = 2.05, p < .05$ ] and Test 4 [ $t(1,42) = 2.52, p < .05$ ]. Although the difference for the Final Exam is not statistically significant, the corresponding letter grade for the Final Exam was a “B” for the 2006 class, and a “C” for 2005 class.

Table 2. Comparison of Circuits student performance for Spring 2006 and Spring 2005.

<b>Categories</b>	<b>Experimental</b> Spring 2006 (ILN) N=41	<b>Comparison</b> Spring 2005 (non-ILN) N=28	<b>Difference</b>
Quiz Average (out of 5)	4.7	3.4	1.3*
Homework Average (out of 10)	9.3	8.6	0.7*
Test Average (out of 100)	76.6	70.8	6.2
Final Exam (out of 100)	83.4	77.8	5.6

\*Note: The difference is statistically significant [  $p < .01$  ].

*Attitudinal survey on Tablet PC and NetSupport School: Spring 2006 only.* Table 3 summarizes the results of the attitudinal survey administered in the Spring 2006 ILN class at the end of the semester. They show overwhelmingly positive attitudes towards the use of both NetSupport School software and Tablet PCs in the classroom. With respect to the use of NetSupport School, the “Help Request” feature was perceived most positively by students, with the control features (locking of student computers, Internet, and Applications controls) viewed the least positively. With respect to the use of Tablet PCs in the classroom, students viewed them as helpful in improving student performance and the instructor’s teaching efficiency, and creating a better learning environment.

Table 3. Summary of student opinions of NetSupport School and Tablet PC use in the classroom.

<b>Use of NetSupport School Software</b>	<b>Average Response</b>
Response Scale: 4 – Strongly Agree, 3 – Agree, 2 – Disagree, 1 – Strongly Disagree, 0 – No Opinion.	(N=37)
NetSupport School program was helpful in improving my performance.	3.49
NetSupport improved the instructor’s teaching effectiveness.	3.64
The “Help Request” feature of NetSupport was useful to me.	3.68
My overall experience with NetSupport School has been positive.	3.67
<b>Use of Tablet PCs</b>	<b>Average Response</b>
Response Scale: 4 – Strongly Agree, 3 – Agree, 2 – Disagree, 1 – Strongly Disagree, 0 – No Opinion.	(N=37)
Using the Tablet PCs in class helped me improve my performance.	3.58
Tablet PC use improved the instructor’s teaching effectiveness.	3.62
I would like to have Tablet PCs available for use in other courses.	3.60
My overall experience with Tablet PCs has been positive.	3.68

When asked the open-ended question what they like most about the NetSupport School software and the Tablet PCs, students responses included increased attentiveness and focus during lectures, real-time assessment of their knowledge through polling, immediate feedback on their work, increased one-on-one time with the instructor, ease of communication with instructor, and quick assistance when needed.

### 3.2 Study 2: Spring 2007 Circuits at Cañada College and San Francisco State University

The performance of the two groups of Circuits students, the ILN Cañada class and the SFSU class that use the standard instructor-centered approach will be compared in this section. Additionally, results of the survey on student engagement, expectations and confidence on mastery of course content will be presented.

*Class performance comparison.* Table 4 shows a comparison of the performance of the two groups of Spring 2007 Circuits students. Quiz Average is the average of four quizzes, Homework Average is the average of the fifteen homework sets, and Test Average is the average of four tests. The last column of Table 4 is the difference between the average scores received by Cañada students and SFSU students. The tabulated results also show higher scores for the Cañada (ILN) class in all categories. Differences between the scores are statistically significant for Quiz Average [ $t(1,20) = 2.56, p < .05$ ], Test Average [ $t(1,35) = 2.11, p < .05$ ] and Final Exam [ $t(1,25) = 2.17, p < .05$ ]. The difference for the Homework Average is not statistically significant.

**Table 4.** Comparison of Spring 2007 Circuits student performance for the Cañada College class and the SFSU class.

<b>Categories</b>	<b>Experimental</b> Cañada (ILN) N=16	<b>Comparison</b> SFSU (non-ILN) N=46	<b>Difference</b> (Cañada – SFSU)
Quiz Average (out of 10)	8.3	7.2	1.1*
Homework Average (out of 10)	8.4	8.0	0.4
Test Average (out of 100)	79.9	72.3	7.6*
Final Exam (out of 100)	86.4	79.4	7.0*

\*Note: The difference is statistically significant [ $p < .05$ ].

*Pre- and Post-Tests.* Table 5 summarizes the results of the Pre- and Post-Tests. Although the Pre-Test scores of SFSU students are slightly higher than those of Cañada students, there is no statistically significant difference between the Average Pre-Test scores. The Post-Test Averages

are significantly higher than the Pre-Test scores both at Cañada [ $t(1,26) = 8.41, p < .001$ ] and at SFSU [ $t(1,79) = 7.50, p < .001$ ]. It should be noted that these tests were designed to be a diagnostic test that measures students' knowledge of basic concepts of electrical circuits and their applications—topics that have been covered in the pre-requisite Physics course. Although the Circuits class increased the understanding and retention of knowledge in these topics for both groups of Study 2, the ILN group's improvement is significantly better than that of the non-ILN group as indicated by the Post-Test results. The average Post-Test score is significantly higher for the Cañada group compared with the SFSU group [ $t(1,29) = 3.97, p < .001$ ].

Table 5. Summary of Pre- and Post-Test Results for Spring 2007 Circuits students for the Cañada College class and the SFSU class.

	<b>Experimental</b> Cañada (ILN) N=16		<b>Comparison</b> SFSU (non-ILN) N=46		<b>Difference**</b> (Cañada – SFSU)	
	Pre	Post*	Pre	Post*	Pre	Post
Average	5.5	12.3	5.7	9.8	-0.2	2.5
Median	5	13	6	10	-1	3
Stand Deviation	2.4	1.9	2.6	2.3	--	--

\*Statistically significant difference [ $p < .001$ ] between Pre- and Post-Test average scores for both groups.

\*\*No statistically significant difference between Canada and SFSU for Pre-Test average scores.

Statistically significant difference [ $p < .001$ ] between Canada and SFSU for Post-Test average scores.

#### 4. Summary And Conclusions

In assessing the impact of the Interactive Learning Network on student performance, it is important to determine how the different components of the model positively or negatively affected student learning. One of the most important components of the Interactive Learning Network teaching model is the immediate assessment of student learning and feedback on their performance. Research on learning theory has long shown that immediate feedback is an effective tool in increasing learning efficiency (Shute, 1994). For the case study at hand, the effect of immediate feedback can be seen in quiz and homework scores of the ILN classes. As a result of solving problems in class with the instructor's guidance, students not only learned the material but gained confidence such that they were more successful in completing homework assignments and were better prepared for quizzes. Consequently, the completion and submission rates of homework assignments for the interactive classes were observed to be higher compared to the traditional instructor-centered classes (greater than 95% completion rate for both interactive groups, and less than 87% completion rate for the non-interactive groups). This difference maybe attributed to a tendency observed by the instructor for students in the non-interactive classes to delay studying class material until immediately before a test. For example,



during exam review sessions many of the questions raised by students in the non-interactive classes were similar to those raised by students in the interactive classes much earlier in the learning process.

Students in the interactive classes also attributed their improved performance to increased focus and attentiveness during class as a result of instructor's survey questions, and the awareness that the instructor observed their progress. Furthermore, the "Help Request" feature of NetSupport was found useful by the students because it allowed them to ask specific questions anonymously. Another advantage of the electronically monitored interactive problem-solving sessions in class was that it enabled the instructor to identify common student misconceptions early in the learning process, thereby reducing student frustration when solving problems on their own. This early assessment of student learning sometimes presented a need for the instructor to adjust course material, making the class more dynamic and more responsive to student needs.

The Interactive Learning Network resulted in better student engagement as evidenced by higher attendance rates and more time spent on assigned tasks outside class time as indicated by an end-of-semester survey. Students also expressed positive attitudes towards the use of the ILN model of instruction, and towards student and instructor use of Tablet PCs in the classroom.

The use of Tablet PCs in the classroom further resulted in a number of distinct advantages that could have contributed to the improved performance of the ILN students. From the students' point of view, the use of Tablet PCs during lectures provided enhanced note-taking ability, and improved their ability to organize class materials and allowed them to integrate hand-written notes and course materials. These features make a Tablet PC highly adaptable to individual students' learning strategies (Ellis-Behnke et. al., 2003). From the instructor's point of view, the use of PowerPoint and Windows Journal in presenting material coupled with the ability to incorporate hand-written annotations, sketches, mathematical equations, derivations, and animations increased teaching efficiency. These class notes, along with annotations generated during lectures, can easily be stored in electronic format and made available for student use outside class.

For the two case studies considered in this paper, there was a statistically significant improvement in performance for the interactive classes as compared to the traditional classes. The observed gains in the Quiz Average were statistically significant for both Study 1 and Study 2. The observed gain in the Homework Average was statistically significant for Study 1 but not for Study 2. The observed gains in the Test Average and Final Exam were statistically significant for Study 2, and not statistically significant for Study 1.

The results of the Pre- and Post-Tests of Study 2 indicate that although both the experimental and comparison groups significantly improved the Test scores during the semester, the gain for the ILN group was significantly higher than the non-ILN group. Since the questions given for the Tests were taken from topics previously covered in the pre-requisite Physics course, these results indicate that not only were there significant gains in the learning of new topics covered in the Circuits class, the ILN model of instruction also proved effective in retaining, understanding, and reinforcing previously learned topics.

In summary, the studies done here show that the interactive learning environment resulted in improvements in student performance compared to the traditional instructor-centered learning environment. These gains can be attributed to enhanced two-way student-instructor interactions, individualized and real-time assessment and feedback on student performance, increased student engagement, and enhanced and more efficient delivery of content.

The studies done here are limited and further studies are needed to be done in larger institutions using multiple sections of the same course to ensure that the experimental and comparison groups are comparable, thus increasing the reliability of the results. These studies should attempt to isolate the impact of the various components of the Interactive Learning Network on student learning to determine whether the immediate feedback through instant polling during lectures, the individual monitoring and assistance during problem-solving sessions, or the combination of both factors are responsible for improved student performance.

Additionally, these studies should attempt to delineate the effects of Tablet PC use by the instructor from the effects brought about by enhanced interactivity due to student use of Tablet PCs in the classroom.

Similar studies should be done on courses with high attrition rates: courses that are traditional “bottle necks” for STEM students, and courses that are problem-solving intensive and requiring high levels of critical thinking. Finally, other software applications that promote interactivity in the classroom should be considered in conjunction with Tablet PC use.

## 5. Acknowledgements

This project was supported by Hewlett Packard through the Technology for Teaching grant. The author would also like to thank Darla Cooper, Michelle Barton, and Kathy Booth of the @ONE Scholar Program, and Charles Iverson of Cañada College for invaluable input, discussions, comments, and suggestions.

## 6. References

- <sup>1</sup>Birk, J., & Foster, J. (1993). The importance of Lecture in General Chemistry Course Performance. *Journal of Chemical Education*, 70, 180-182.
- <sup>2</sup>Meltzer, D. E., & K. Manivannan, K. (1996). Promoting Interactivity in Physics Lecture Classes. *The Phys. Teacher*, 34, 72-76.
- <sup>3</sup>Felder, R.M., Felder, G. N. & Dietz, E. J. (1998). A Longitudinal Study of Engineering Student Performance and Retention. V. Comparisons with Traditionally-Taught Students, *J. Engr. Education*, 87, 469-480.
- <sup>4</sup>Rodger, S. H. (1995). An Interactive Lecture Approach to Teaching Computer Science. Proceedings of the twenty-sixth SIGCSE technical symposium on Computer science education, 1995, Nashville, Tennessee, United States, 278 – 282.
- <sup>5</sup>Beekes, W. (2006). The ‘Millionaire’ Method for Encouraging Participation. *The Journal of the Institute for Learning and Teaching* 7, 25-36.

- <sup>6</sup>Rummel, N., & Spada, H. (2005). A Learning to Collaborate: An Instructional Approach to Promoting Collaborative Problem Solving in Computer-Mediated Settings. *The Journal of the Learning Sciences* 14, 201-241.
- <sup>7</sup>Koile, K., & Singer, D. A. (2006). Development of a Tablet-PC-based System to Increase Instructor-Student Classroom Interactions and Student Learning. *Proc WIPTE 2006 (Workshop on the Impact of Pen-Based Technology on Education)*, Purdue University.
- <sup>8</sup>Rogers, J. W., & Cox, J.R. (2008). Integrating a Single Tablet PC in Chemistry, Engineering, and Physics Courses. *Journal of College Science Teaching* 37, 34-39.
- <sup>9</sup>Ellis-Behnke, R., Gilliland, J., Schneider, G.E., & Singer, D. (2003). *Educational Benefits of a Paperless Classroom Utilizing Tablet PCs*. Cambridge, Massachusetts: Massachusetts Institute of Technology.
- <sup>10</sup>Colwell, K. E. (2004). Digital Ink and Notetaking, *TechTrends* 48, 35-39.
- <sup>11</sup>Goodwin-Jones, B. (2003). E-Books and the Tablet PC. *Language Learning & Technology* 7, 4-8.
- <sup>12</sup>Anderson, R.J., Anderson, R.E., Davis, P., Linnell, N., Prince, C., Razmov, V., and Videon, F. (2007). Classroom Presenter: Enhancing Student Learning and Collaboration with Digital Ink. *IEEE Computer Magazine*, 36-41.
- <sup>13</sup>Price, E., Malani, R., & Simon, B. (2005). Characterization of Instructor and Student Use of Ubiquitous Presenter, a Presentation System Enabling Spontaneity and Digital Archiving. *2006 Physics Education Research Conference, AIP Conference Proceedings*, 893, 125-128.
- <sup>14</sup>Shute, V. (1994). *Handbook on Research on Educational Communications and Technology Research and Development Division, Educational Testing Service*. Princeton, New Jersey.

## Biographical Information

Amelito Enriquez received his BS in Geodetic Engineering from the University of the Philippines at Diliman, his MS in Geodetic Science from the Ohio State University, and his PhD in Mechanical Engineering from the University of California, Irvine. His research interests include technology-enhanced instruction and increasing the representation of female, minority and other underrepresented groups in mathematics, science and engineering.

## Using an On-line Survey Tool to Streamline Outcomes Assessment

Phillip R. Rosenkrantz, Ed.D., P.E.  
Industrial & Manufacturing Engineering Department  
California State University, Pomona

### **Abstract**

Outcomes assessment required to meet ABET accreditation criteria can be very time consuming. Deciding what and how to measure can take many hours of faculty time on both a department-wide and individual basis. Data gathering and analysis is another time consuming activity. Finally, preparing self-studies and other reports can consume many hours as well. It was College of Engineering's Assessment Committee conclusion after two rounds of ABET Assessment under the ABET 2000 criteria that a more strategic and systematic approach was needed for gathering and organizing data. In an effort to simplify assessment processes, the IME Department at Cal Poly Pomona has been increasingly using SurveyMonkey on-line surveys to gather data from students, alumni, faculty, and industry. One of the reasons for widely adopting SurveyMonkey is the ability to create a data base that makes it easier to collect and analyze data, share results, and prepare descriptive statistics of results over time. The purpose of this paper is to show how SurveyMonkey can be used for various assessment situations and demonstrate how easy it is to create a data base in the process.

### **Introduction**

One of the top objectives of the College of Engineering Administrative and Assessment Committees and after the last ABET accreditation cycle was to streamline and simplify data collection and analysis processes. In 2005 the process of gathering together relevant data and analysis in order to report by criteria and a-k designation was extremely time consuming for many programs. One of the main reasons for the large time requirement was that assessment data and other reported information was in various forms such as hard copies and raw data reports. Subsequently entering data into a spreadsheet and performing analysis was very time consuming.

The IME Department decided to re-engineer as many assessment tools and instruments as possible so that an on-line survey tool could be used for input and serve as a data base. SurveyMonkey was the on-line survey service used, however there are a number of other on-line services that would work similarly (such as Zoomerang). SurveyMonkey was chosen primarily because at the time it had good features, very few restrictions on the number of surveys that could be collected, and was competitively priced. Another attractive feature was that surveys could be easily transferred between paid users. Other services may offer more features and should be considered when deciding which service to use.

The purpose of this paper is to show how SurveyMonkey is being used for both formative and outcomes assessment. Outcomes assessment can be conducted at the course and/or program levels. Emphasis will be on the variety of things that can be done, time savings, and the ability to create data bases of gathered data. First

After the 2005 ABET accreditation visit the College of Engineering Assessment Committee and Administrative Committee used a survey to set the agenda for the next year regarding priorities to work on. In reality the results were used for several years.

### **Design and Deployment Features**

- **Relatively inexpensive for the features provided** – Both SurveyMonkey and Zoomerang offer monthly “Pro” packages for approximately \$19/month. Annual packages are available for \$200/year. The number of surveys and responses allowed is well within the amount needed.
- **Ease of creating a survey from scratch or starting with a previous survey** – Survey building is very user friendly and old surveys can be imported as templates for new surveys.
- **Color schemes and customized page design** – There are many color schemes and formats to choose from. Customized designs can be created with a little more effort.
- **Paging and end of survey options** – Surveys can be one page long or broken into separate pages. Responders can be sent to various “thank you” or other pages as designated by the designer.
- **Can embed survey links in email, web pages, or send to an email list with reminder capability** – Links are provided allowing for embedding survey links in various documents. Surveys can also be sent to an email list allowing for tracking and reminder messages. Practice has shown that the reminder feature does produce good results with second and third reminders.
- **Surveys can be opened or closed for data collection as necessary.**

### **Analysis and Sharing Features**

- **Sharing survey results** – Unfiltered survey results can be shared with others with various levels of interaction allowed. Sharing can be password protected. Sharing is a useful feature for displaying assessment results with colleagues. The boilerplate display screens are very aesthetic.
- **Ability to filter the results by response alternative (e.g., demographic or specific question choice) and save filters by name** – The same survey can be used for various

courses, student groups, years, and semesters. Results can then easily be filtered to a specific demographic combination. This avoids having to create a new survey for each time you want to use the survey.

- **Ability to collect surveys with options required for IRB approval** – settings are available to create various levels of anonymity and confidentiality, depending on what is needed for IRB approval. (e.g., IP address, email address, and other information can be included or excluded, depending on settings).
- **Can create crosstabs for up to five choices for any question** – Powerful, but limited option.
- **Survey data downloadable in various forms depending how needed** – Data can be downloaded to a spreadsheet as raw data or summarized various ways.
- **A virtual database can be created by carefully choosing questions** – Demographic questions can be discretely used to create a data base allowing for analyzing data over time. This is a useful feature for outcomes assessment.

### Examples of survey use

Below is a partial list of surveys divided into categories. Almost all examples are related to outcomes assessment. Examples are shown at the College of Engineering level, program level and course level. In some courses SurveyMonkey is being used for course management and/or formative assessment as shown with a few examples. The following link is to the IME Department Assessment Page which includes links to several of the surveys. Readers are welcome to look at these surveys and use them as needed:

<http://www.csupomona.edu/~rosenkrantz/imeassessmentdocs.htm>

### College Level Assessment

- **Cal Poly Pomona Project Symposium Feedback** – Industry visitors to senior project presentations were surveyed for their overall assessment of outcomes vs. importance. A gap analysis was easily created using summarized survey data.
- **College of Engineering Assessment Interest Survey** – College faculty and administrators involved with preparing the self study were surveyed to identify assessment committee priorities for the near future.

### Program Level Assessment

- **Cal Poly Pomona IME Department 2005 Alumni Survey** – Survey administered every three years to assess progress on objectives and obtain feedback regarding changing curriculum needs.

- **Student Advising Survey** – Comprehensive survey to explore student attitudes and practices so the IME Department could revise the advising program based on actual student feedback.
- **IME Basic Knowledge Survey** – Survey used to assess student retention of knowledge and concepts from five selected lower division courses. Very valuable in finding out where to put place efforts to increase learning. The use of valid and reliable concept surveys should be encouraged.
- **ME Summer Class Needs Survey** – A quick survey of ME students regarding what summer course offerings would be the most valuable resulted in higher-than-expected summer course attendance.

### Course Level Management & Assessment

- **IME Outcomes Assessment Survey** – Survey of student progress in a-k outcomes for a selection of courses. This survey is the main outcomes assessment tool that looks for improvement over time and weaknesses that should be targeted for special attention.
- **IME 312 Statistics Knowledge Survey** – Utilizes a pre and post knowledge survey to assess student learning by topic and by level of learning from Bloom's Taxonomy.
- **EGR 403 On-line Introductory Survey** – Survey used to find out student interests, strengths, and weaknesses for the purpose of forming student project teams
- **EGR 403 Team Member Evaluations** – Student assessment of team members. Used midway through and at the end of the project to assessment contribution to the team project.
- **IME 301 Project Proposal** – Survey used as a proposal form for student data collection and analysis projects. This method is faster and more efficient than Blackboard

### First Year Experience

- **Engineering First Year Experience Survey** – Survey designed specifically to assess the results of the EGR 100 first year experience course for incoming students.
- **IME 112 Team Evaluation Survey** – Introductory course team evaluation survey.
- **IME 112 Time Use & Management Survey** – Survey based on time management assignment results. Provides feedback to both students and the instructor about student habits and practices.
- **IME 112 Outcomes Survey** – Student assessment of specific features and outcomes from for the introductory course.

### Capstone Course Sequence Assessment (IME 460, IME 461/471, IME 462/472)

- **IME 460 Fall 08 Sample Senior Project Report Assessment** – Survey made using the senior project written report rubric. Students use this to practice scoring written reports as part of a Senior Project preparation course.
- **IME 460 Sample Senior Project Presentation Assessment** - Survey made using the senior project oral presentation rubric. Students use this to practice scoring video tapes of oral report reports as part of a Senior Project preparation course.
- **IME 460 Senior Project Report Assessment** – Faculty are asked to input their assessment of written senior project reports using SurveyMonkey.
- **IME Reflective Piece Results** – A single evaluator is asked to input an assessment of a reflective piece written by students after completion of the senior project. The survey covers three outcomes scored by a rubric.
- **IME Department Senior Project Assessment** – Survey developed to gather feedback from industry about the professionalism of students who completed Senior Projects at their company. The survey link is sent out in an email message.

### Additional information regarding downloading

The italicized section below is a copy of the download option page in SurveyMonkey. It shows the various options available for downloading results. Spreadsheet, HTML, and pdf formats are available along with choices for raw or summarized data. Note that the descriptions are not that clear so expect to experiment with downloading to find the exact format to meet your needs.

*Choose Type of Download*

**Summary Report**

*Download a summary report of your survey that you can save or print.*

**All Responses Collected**

*Download the entire response set of your survey, for importing into a spreadsheet or database.*

**Columns:**

*Choose whether question choices are condensed or expanded to fit one or multiple columns.*

**Cells:**

*Choose what data appears in the spreadsheet.*

*Choose Format*

**CSV Format**

*The summary is formatted as a comma separated values file.*

**Spreadsheet Format**



*The summary is formatted to open with spreadsheet software.*

**XML Format**

*The summary is formatted as an XML file.*

**HTML Format**

*The summary is formatted in HTML, and can be easily posted on a website.*

**PDF Format**

*The summary is formatted as a PDF, and can be easily printed.*

**Orientation:**

**Paper Size:**

*Open-Ended Responses (optional)*

**Include Open-Ended Responses in Download**

*Apply Existing Crosstab (optional)*

**Use Current Crosstab Named "New Crosstab"**

## **Conclusions and Recommendations**

There are many more uses of a survey tool than just for the common “end of course” survey. On-line surveys can save much time and effort compared to handwritten surveys and OCR forms.

An on-line survey tool can be creatively used for a variety of time-saving data collection processes.

Sometimes the difficulty in summarizing and analyzing data delays the effort and ultimately affects the implementation of changes. If properly planned out, the number of hours required for analysis, feedback, and planning for change can be reduced and program effectiveness can be promoted sooner.

Creation of descriptive statistics for generating a thoughtful self study is time consuming. Having data in a form that is already in a spreadsheet format makes this task much easier.

## References

Allen, K. 2006. *The Statistics Concept Inventory: Development and Analysis of a Cognitive Assessment Instrument in Statistics*. School of Industrial Engineering, University of Oklahoma.

Nuhfer, Edward, and, Knipp, Delores, *The Knowledge Survey: A Tool for All Reasons*, (2003, *To Improve the Academy*, v. 21, pp. 59-78.)

## Biography

### DR. PHILLIP R. ROSENKRANTZ

Professor of Industrial & Manufacturing Engineering, California State Polytechnic University, Pomona since 1982 (Chair 1990-1997). IE and IE supervisor for General Motors for nine years prior to academia. Education: Ed.D. in organizational leadership from Pepperdine University; MS in Statistics from UC Riverside; MS in Industrial Administration from Purdue University; and Bachelor of Mechanical Engineering from Kettering University (formerly GMI). P.E. (California)

## Photonics Research and Education at California Polytechnic State University

Xiaomin Jin, Dennis Derickson, Simeon Trieu, and Samuel O. Agbo  
Electrical Engineering Department, California Polytechnic State University, San  
Luis Obispo, CA 93407

### Abstract

California Polytechnic State University is a major undergraduate teaching institute. We have a very active photonic teaching and research program in the Electrical Engineering (EE) department. In the recent years, the photonics group went through a big transition of the program with one professor retirement (founder of the program) and two new faculty members arriving. Our recent activities comprise following three major parts: 1) Expanded teaching laboratory, 2) Strong faculty/students research projects, and 3) Active SPIE student club. We are presenting the above three efforts in this paper.

### 1. Introduction

California Polytechnic State University (Cal Poly) has one of the nation's largest primarily undergraduate engineering colleges. The photonics program within the EE department began in 1985. Currently, there are two senior elective lecture courses and one graduate-level lecture in the photonics area. A 700 ft<sup>2</sup> fiber-optics laboratory was introduced in 1986. This laboratory serves dual purpose for undergraduate teaching (3 benches) and undergraduate/graduate research (1 bench). The Photonics laboratory has undergone a series of equipment and laboratory procedure improvements and since its inception. The 700 ft<sup>2</sup> room size limited teaching section size to 9 people and this made it one of the department's most expensive laboratories to teach. The demand for the class has been high resulting in a large teaching demand to service the students. The laboratory underwent an expansion in 2008 to a double size room of 1400 ft<sup>2</sup> allowing 18 students per classroom section, with six undergraduate teaching benches and two undergraduate/graduate research benches. The high cost of equipment per bench/station has necessitated rotation of experiments to minimize capital equipment expenditures for the new lab. Fig. 1 is one corner of the photonic lab. It shows two teaching benches with students working on their experiment. Overall, the newly innovated photonic lab not only serves the teaching lab better, but it can also support more undergraduate/graduate student projects, such as senior project and master's thesis, which are very important laboratory experience. Moreover, one recent focus of photonic lab has been university – industrial collaborative projects, which is addressed in the paper. Finally, the Cal Poly SPIE student club is very active in the past four years. It has been a companion technical and social activity source for students interested in the photonics field.



Fig. 1 A corner of the photonic lab. It shows two teaching benches with students working on their experiment.

## 2. Innovative lecture and teaching laboratory

The Cal Poly Photonics faculty initiated an update our photonic courses three years ago focusing on EE403 Fiber Optic Communication and EE443 Fiber Optics Laboratory. In winter 2005, we adopted a new textbook for EE403 and added multimedia course material in the lecture. To match the new EE403 class, new EE443 lab experiments were required. The old lab experiments were:

- Experiment Prelim: Digitizing Oscilloscope (DSO)
- Experiment 1: Handling Fiber, Numerical Aperture
- Experiment 2: Attenuation, Splicing, OTDR
- Experiment 3: Single Mode Fiber, Source characteristics
- Experiment 4: Source, Coupling to Optical fiber
- Experiment 5: Bandwidth of an optical Fiber

These five laboratory experiments were primarily focused on the device-level experiments. For the lab expansion, a new emphasis on adding system-level experiments was made:

- ***Experiment 5-NEW: Optical Link Experiment (added in Fall 2008)***

The laser function generator instrument (1985 vintage) of the old Lab No.5 had multiple failures and the instruments are now unrepairable. Only one station out of the four duplicate sources was fully functional. The old experiment 5 was replaced with a modern fiber optic link source and receivers using SFP fiber optic transceivers. The new Lab 5 Optical Link Experiment shows students how to build a modern fiber optic digital link using standard optical transceivers. This experiment also preserves the old experimental goal of estimating the bandwidth of a 1 km multimode fiber spool.

- ***Experiment 6: EDFA:(added in Fall 2007)***

Lab 6 EDFA was first designed and deployed in the EE443 lab in Fall of 2007. This lab teaches students about Erbium Doped Fiber Amplifiers (EDFA) and their applications. Erbium doped fiber amplifiers were only in the early research stage when the photonics lab was initially established at Cal Poly. This lab contains both EDFA system hardware characterization and Computer Aided Design (CAD) simulation of systems utilizing optical amplifiers. The CAD tool allows the students to explore a variety of EDFA architectures that would take too much time to build during a laboratory session.

- ***Experiment 7: OPTSIM Preliminary Experiment (added in Fall 2008)***

Through this lab, the students are exposed to a CAD program that can simulate a wide range of fiber optic links. The simulation can be used to compare experimental results such as the link of experiment 5 or newer designs which are too time-consuming and expensive to build. Rsoft's OptSim simulation tools have been our focus system simulation CAD tool for fiber optic links.[1]

- ***Experiment 8: OPTSIM NRZ Optical System and OSNR Spectrum Chart (added in Fall 2008)***

Students use OptSim to calculate the Optical Signal-to-Noise Ratio (OSNR) and optical spectral content of a 10 Gb/s optical system with EDFA preamplifiers, mid-link amplifiers and booster amplifiers. The 10 Gb/s NRZ optical signal is launched into 3 spans of Dispersion-Shifted single mode fiber, each 50 Km in length. The fiber loss is recovered by 980-nm pumped EDFA before each span and after the third span. The optical signal is passed through a raised-cosine filter and detected by a sensitivity avalanche photodiode receiver. The electrical output of the receiver is passed through a Bessel filter to limit the bandwidth of the electrical receiver and maximize sensitivity. The student laboratory assignment includes optimization of the system signal to noise ratio.

- ***Experiment 9 (optional) 4 Channel WDM***

The students design a simple 4-channel wavelength division multiplexing (WDM) system using the OptSim simulation tool. Since the hardware associated with a WDM system is very expensive system for a student teaching lab, the simulation illustrates key design concepts unique to WDM systems. The system design requirements are: Design a 4-channel WDM transmitter at 2.488 Gb/s with a NRZ modulation format and a p-i-n photodiode receiver. The four signals are pre-amplified by an EDFA booster and transmitted over a sequence of two Dispersion Shifted fiber spans of 100 km each. The fiber spans have opposite dispersion signs ( $D = \pm 2.16$  ps/nm/km) resulting in ideal dispersion compensation at the middle of the simulated bandwidth. A second EDFA is used in the receiver section as a preamplifier.

***This photonic lab expansion project*** was a joint effort of students, professors, EE technician staff, and the EE department leadership. The driving goal of the expansion was to serve the continued high demand for our photonics lecture/lab courses and minimize the number of laboratory sections to service this need. First, professors set up the lab expansion goal and topics. And we looked for both external and internal funding sources to implement our new laboratory exercise goals. Second, students were enlisted to help design and troubleshoot the new experiments under the guidance of professors as their senior projects for the past three years.

Finally, department allocated \$60,000 of internal funding to complete the costs of doubling the teaching space allocation from 700 ft<sup>2</sup> to 1400 ft<sup>2</sup>. This included the purchase of four new optical benches, equipment racks, computers and infrastructure changes. Test equipment donations from industry also helped to populate the expanded number of laboratory stations.

The original laboratory had three optical tables for teaching purposes. Each table allow a maximum 3 students to do one set of experiments. Therefore in each three-hour lab section, there were only maximum 9 students. We had to offer at least 4 lab sections each quarter to match each the EE403 lecture or EE418 lecture size. The large number of required lab sections was a driving force for the financial support of the EE department leadership group. The most straightforward approach might have been to purchase identical test and measurement solutions for the 3 new benches associated with the doubling of the photonics laboratory area. However, most of the older lab test and measurement equipment was 10 years old and it did not make sense to try and duplicate the old measurement station equipment. The cost of providing a complete section of next generation test and measurement for the three new optical benches was also too expensive to implement over a short period of time.

A compromise solution was reached. We capped enrollment at 2 lab sections each quarter with 18 students in each section. This contrasted to the earlier format of instead of 4 sections of 9 students with the smaller sized laboratory. The doubling of lab size from 700 ft<sup>2</sup> to 1400 ft<sup>2</sup> was accomplished by constructing a curtained opening between the original room RM 20-314 (original photonics laboratory) and the adjacent room RM 20-315 (old digital signal process DSP lab). The expanded lab area in room 20-315 now contains our new set of laboratory exercises 5 through 9. The original room utilizes the old laboratory experiments 1-4. We place six teaching benches with two set of experimental setups, as shown in the Fig. 2 below. The students will be in two groups (group A and group B) and switch experiments every two weeks.

The following objectives were achieved with the laboratory expansion and upgrade:

1. Increase enrollment from 9 to 18 students per laboratory section. It is estimated that the EE department's \$60k expansion cost will be repaid in less than 3 years by reducing teaching hour demands for the course.
2. For each experiment with large capital expense, equipment spares were put in place. Four duplicate equipment copies instead of six copies are needed for each experiment.
3. Compatibility was maintained with the existing experiments 1-4 and their associated equipment needs.
4. The new optical bench space is not fully occupied leading to the ability for future laboratory enhancements.
5. The added space gives a larger open area to facility lecture/lab capabilities in the same room.
6. An additional optical bench was dedicated to senior project activities and master's thesis projects.

With department supports and approval, the expanded laboratory opened in the fall of 2008. A second undergraduate photonics lecture/laboratory course, EE458 is now being targeted for expansion to include 18 students per sections.

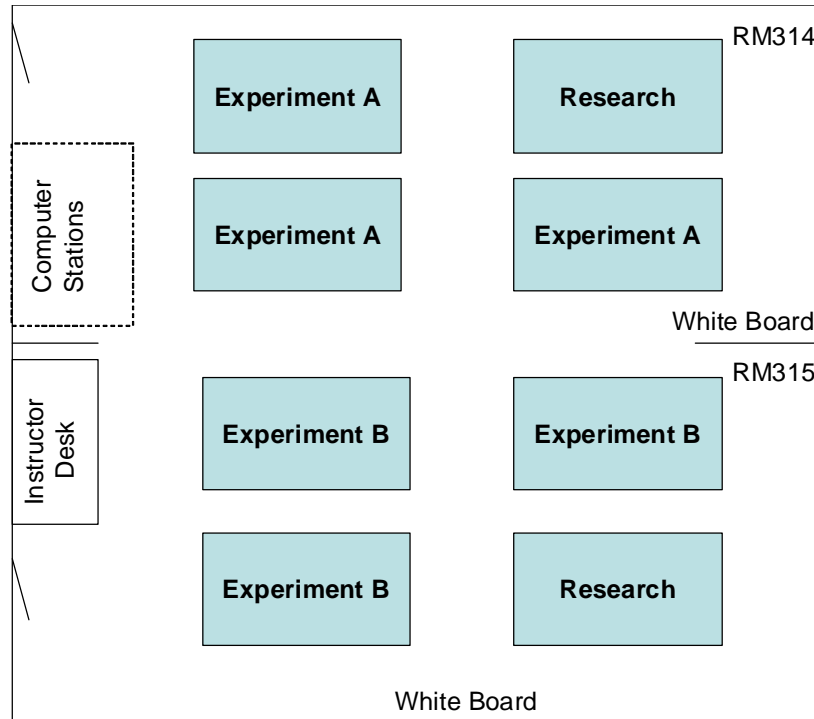


Fig. 2 The layout of new experiment setup and new research benches in EE photonic lab.

### 3. Strong faculty/students research projects:

With the photonic lab expansion project, the department also doubled its photonic research/project area in 2008. This will support more photonic faculty/student projects. The major projects are:

- **International research collaboration [2]**

We established a long-term cross-three-campus international engineering education and research collaboration program among California Polytechnic State University (Cal Poly), USA, California State University, Long Beach (CSULB), and Peking University (PKU), Beijing, China on GaN light emitter research in the past four years. The research is focused on GaN laser diode topics for the first year. GaN Light emitting diode research was added during the second year and nanostructure grating simulation was emphasized on the third year. LED control circuit research is under development now in the fourth year. The effort has been supported by the Wang Faculty Fellowship through California State University international programs and other funding. Faculty members, Dr. Jin (Cal Poly) and Dr. Wang (CSU Long Beach), worked at PKU during the summer of 2006 to initiate a joint research project on GaN laser diodes. In the following years (2007 and 2008), they continued this effort with two summer visits and further extended the project to include research on GaN light emitting diodes, with funding from the US (Cal Poly) and China (“ChunHui” international scholar exchange program). A graduate student, Simeon Trieu, from Cal Poly also visited PKU in the summer of 2008 and is applying NSF EAPSI (applied in Dec 2008 and got initial acceptance letter from NSF) and other support to work in PKU in the summer of 2009. Cal Poly/CSULB graduate students are grouped with

graduate students in Peking University and worked closely on mutually defined projects. The participating students obtain experience in transcontinental collaboration and gain an awareness of culture differences. Three journal papers and five conference papers on GaN research and education have been published by participating researchers since 2007. [2][4]-[10] A paper is accepted for conference presentation in April 2009. [11] Student comments from both continents confirm that they obtain better understanding about foreign cultures as a result of this activity. Student comments indicate they believe that this activity will be helpful for job prospects in multinational engineering firms. Currently plans include involvement of undergraduate students into this project in order to extend the education scope.

- **Research Lab-Cal Poly collaboration**

We also collaborate with Lawrence Livermore National Labs (LLNL). LLNL has offered a graduate study internship in conjunction with Cal Poly since 2004. Cal Poly faculty members identify prospective student candidates for the graduate internship. Dr. Agbo is the LLNL coordinator for Cal Poly. During the past three summers, Dr. Agbo also worked at LLNL as a Summer Faculty Scholar on an Ultra-Wideband (UWB) Communication project. An UWB system utilizes an enormous bandwidth, but because it operates at very low power levels comparable to the noise level. Because of the low spectral density of the modulation, it can overlay other channel plan allocations. Therefore, it requires no bandwidth assignment from the Federal Communications Commission.

- **Industry sponsored projects**

The EE photonic faculty is principle investigators of various industrial and/or government agency sponsored projects:

A partial list of Dr. Jin's recent projects include "Simulation of the 633nm photodetector using Crosslight" funded by Agilent in 2008, "Modeling and testing of semiconductor lasers, cables, and photodiodes for interferometer measurement system applications" sponsored by Agilent Global Research Grant in 2006-2007, and "Investigation of photonic lattice based Gallium-Nitride light emitters" funded by the Office of Naval Research (via C3RP program). She also collaborated with several industrial companies, including *Rsoft Design Inc* and *Crosslight Inc*.

Dr. Derickson has cooperated with JDS Uniphase Corporation on tunable laser projects and published several papers on the topic. [12] [13] Fig. 3 is a Cal Poly graduate student presenting paper on microwave signal generation using self-heterodyning of a fast wavelength switching SG-DBR Laser in the SPIE International Symposium on BIOS 2009, SPIE Photonic West 2009 in January 2009 on the JDSU project. [13] In this paper, microwave signal generation using single-chip fast wavelength-tunable SG-DBR lasers is demonstrated. Microwave signals are established by a self-heterodyne technique. The laser frequency is square-wave modulated back and forth between two closely spaced wavelengths. These two wavelengths are made time coincident using a fiber Mach-Zehnder interferometer. The difference frequency is detected and amplified. Microwave signals up to 12 GHz have been measured by frequency modulating the phase section of the SG-DBR laser. Millimeter wave difference frequencies are easily available from the SG-DBR laser. Microwave signal spectral widths as narrow as 10 MHz have been achieved for low back mirror current inputs. Spectral width results as a function of device DC bias condition are presented. A high-speed wavelength switching SG-DBR package has been



built for this application. Time resolved frequency step measurements have shown inherent thermal transients of approximately 200 ns upon wavelength switching. From the square wave switching profile, switching times of approximately 40 ns were achieved.

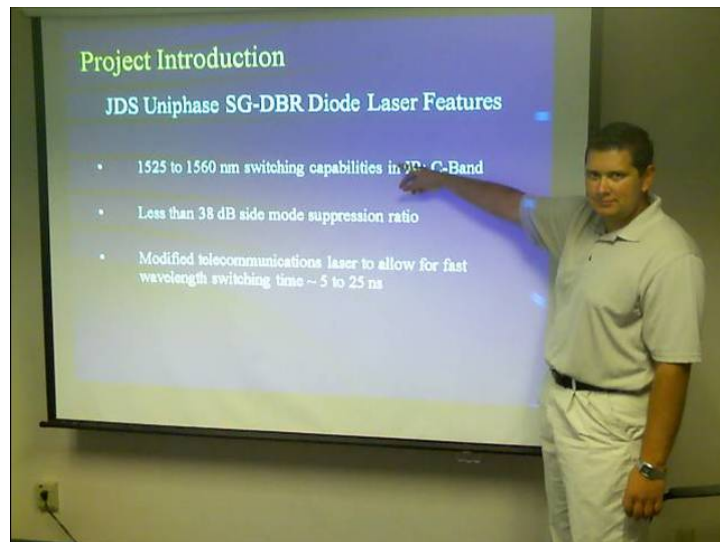


Fig. 3 A Cal Poly graduate student presenting paper on microwave signal generation using self-heterodyning of a fast wavelength switching SG-DBR Laser in the SPIE International Symposium on BIOS 2009, SPIE Photonic West 2009 in Jan 2009 on the JDSU project

#### 4. Active SPIE student clubs [3]

A SPIE student club was formed in 1986 so that students who had an interest in photonics could have a common forum and bond together as an entity. Leading by Dr. Derickson, SPIE student club is very active in the past four years. Each year, SPIE also offers 2 major conference events that are within driving distance of Cal Poly. Photonics West is held in San Jose each January and the SPIE annual meeting is held in San Diego each August. Both of these events offer great opportunities for students to observe first-hand the diversity of the photonics field. SPIE offers student scholarships for travel to the conference. The students group meets bi-weekly and features guest speakers on a range of photonics related topics along with free pizza and soda. Several social events are also organized throughout the year. SPIE is a generous funding organization for student chapters. Students join the SPIE organization for \$20 per year. The membership includes journal publications and a monthly news magazine. SPIE then donates operating funds back to the student chapter in proportion to the number of student members. SPIE offers student scholarship, activity grants and pays for guest speaker forum for its student chapters.

Another major focus of the SPIE student chapter each year is to provide a display at Cal Poly's open house celebration. Annual crowds of over 10,000 people gather together on campus in April to see activities from the departments and student clubs. The entire event is student managed. This activity again helps form an identity for those students interested in the photonics field and offers new students, parents, and their siblings a chance to see photonics in a fun-filled hands-on display.

## 5. Conclusion

In summary, this paper described efforts to allow Cal Poly's EE photonics program produce a more modern photonics education program to meet current education goals: modernize existing lab with low cost and compatibility with older labs; introduce an international educational element; project-based learning; team based learning; and photonics CAD-based learning.

## Reference

- [1] Rsoft Design Group, Inc, <http://www.rsoftdesign.com/>.
- [2] X. Jin, B. Zhang, F.Wang, J. Flickinger, S. Jobe, T. Dai, G. Zhang, "International Engineering Research and Educational Activity on GaN Lasers and LEDs", International Association of Journals and Conferences (IAJC)-International Conference, International Journal of Modern Engineering (IJME) IAJC-IJME 2008, November 18-22, 2008, Nashville, Tennessee.
- [3] D. Derickson, S. Agbo, S. Jobe, J. Sharpe, D. Wasche, and X. Jin, "Photonics Education Program at California Polytechnic State University", Education and Training in Optics and Photonics 2007 (ETOP 2007), Ottawa, Canada, June 2-3rd, 2007.
- [4] X. Jin, B. Zhang, T. Dai, W. Wei, X. N. Kang, G. Y. Zhang, S. Trieu, and F. Wang, "Optimization of Top Polymer Gratings to Improve GaN LEDs Light Transmission", OSA Journal: Chinese Optics letters (Focus Issue Nano Photics), vol.6, no. 10, pp. 788-790, 2008.
- [5] X. Jin, B. Zhang, T. Dai, and G. Zhang, "Effects of Transverse Mode Coupling and Optical Confinement Factor on Gallium Nitride-Based Laser Diode" The Institute of Physics: Chinese Physics vol 17, no.4, pp-1274-1278, April 2008.
- [6] X. Jin, B. Zhang, L. Chen, and G. Zhang, "The Optimization of Gallium Nitride-Based Laser Diode through Transverse Modes Analysis", OSA Journal: Chinese Optics letters vol.5, no. 10, pp. 588-590, 2007.
- [7] S. Trieu, X. Jin, B. Zhang, T. Dai, K. Bao, X. N. Kang and G. Y. Zhang, "Light Extraction Improvement of GaN-based Light-emitting Diodes using Patterned Undoped GaN Bottom Reflection Gratings", the SPIE International Symposium on Integrated Optoelectronic Devices 2009, SPIE Photonic West 2009, San Jose, CA USA 24-29, January 2009.
- [8] X. Jin and S. Trieu, "Improvement of Light Transmission using Photonic Lattices for Solar Cells," OSA Topical meeting, Solar Energy: New Materials and Nanostructured Devices for High Efficiency, June 24-25, 2008, Stanford University, Stanford, California, USA.
- [9] X. Jin, B. Zhang, S. Jobe, J. DeLeon, J. Flickinger, T. Dai, G. Zhang, E. Heller, and L. Chen, "Two-Dimension Simulation of Gallium Nitride-Based Laser Diode", The 7th International Conference on Numerical Simulation of Optoelectronic Devices (NUSOD 07), Delaware, United States, 24 - 27 September 2007.
- [10] X. Jin, B. Zhang, L. Chen, S. Jobe, T. Dai, and G. Zhang, "The Optimization of Gallium Nitride-Based Laser Diode through Transverse Modes Calculation" The OSA Topical Conference on Nanophotonics (NANO 2007), 6/18/2007 - 6/21/2007, Hangzhou, China.
- [11] X. Jin, S.Trieu, Fei Wang, B. Zhang, T. Dai, X. N. Kang, and G. Y. Zhang, "Design Simulation of Top ITO Gratings to Improve Light Transmission for Gallium Nitride LEDs", 2009 Sixth International Conference on Information Technology: New Generations, ITNG2009, April 27-29, 2009, Las Vegas, Nevada, USA (Accepted).
- [12] D. Derickson, A. Dekalaita, B. Maher, M. Bernacil, S.O'Connor, M. Sysak, and L. Johanson "Single Chip Tunable Lasers for Swept -Wavelength Optical Coherence Tomography", at BIOS 2008. This conference is part of the SPIE Photonics West symposium in January 2008.
- [13] Dennis J. Derickson, Shane A. O'Connor, Michael Bernacil, Andrew J. DeKelaita, Ben Maher, "100 kHz axial scan rate swept-wavelength OCT using sampled grating distributed Bragg reflector lasers", the SPIE International Symposium on BIOS 2009, SPIE Photonic West 2009, San Jose, CA USA 24-29, January 2009.

# Longitudinal Contact with Individual Students as a Route of Encouraging Self-Determination in Chemical Engineers

Paul Blowers

Department of Chemical and Environmental Engineering

The University of Arizona

## Abstract

It is difficult to have contact with individual students over a sustained period of time due to constrained schedules and competing time demands. However, frequent contact with individuals over time allows advisors to build student strengths in self-determination while tailoring advice directly to changing interests.

The talk will highlight advising opportunities from outreach, through retention, continuing to graduation, and post graduate interactions that fit within student progress towards their individual careers. Appropriate advising content for a technically rigorous chemical engineering program will be used as examples of how to motivate students towards exploring options and making decisions that open new doors to professional development. The issue explored is that self-determination comes from inside the student and that confidence in personal evaluation is fostered through directed activities throughout students' time with us.

Objectives that readers should be able to meet will be:

- to have the ability to identify points of contact where longitudinal contact can be encouraged
- to have the knowledge of how to remove impediments to longitudinal advising through reconstruction of advising duties in larger programs with many staff members, or through directed contact with students in smaller departments
- To have the ability to link student possibilities to exploratory activities that lead to self-determination

Students in chemical engineering are generally very strong in academic abilities, but often have not been exposed to a breadth of activities and possibilities that enable them to construct their own paths. Sustained advising contact has led to strong statistically-based success of students who have progressed through our program with approximately 30% of our graduates entering top ten chemical engineering graduate programs, 100% student placement of graduates almost every year, and a host of university-based, state, and national awards going to our students.

## Introduction

Most faculty appointments in the United States carry the expectation that there will be a balance among different work activities[1-4]. The typical assumed split on a time percentage basis is 40% on research, 40% on teaching, and 20% on service, although those percentages vary in reality[5]. One way of meeting service obligations is for faculty to take on the task of advising students in their disciplines[4, 6, 7]. Activities in the advising area provides service to many constituents, including to the students, to the department, to the profession, and to our

stakeholder companies, employers, and the general public. Students benefit directly from the close communication and exposure to ideas of an "expert" in the area of academic development. The department benefits directly by smoothing the progress of students through their programs while maintaining high standards and increasing statistical measures often used for evaluation of programs like retention, average student time to graduation, and student contact hours. The profession is improved by the production of students who are prepared to think rigorously about their own development and how to engage in life long learning. Stakeholder companies and employers benefit by a larger pool of graduates that may be more highly qualified than a student pool that had been unadvised. Finally, the general public benefits through the production of responsible citizens who contribute not only to the financial health of their local economies, but also through the goods and services provided by educated engineers.

While the benefits of advising were listed above, the purposes of advising are more focused on the students. Navigating engineering curricula is not easy for most students. There are many constraints placed on course offerings, timing of events, prerequisite courses needed for advancement, grade point needs, and other academic concerns. Students often struggle along the way when a situation occurs that moves them farther away from the norm of progress, and they can leave engineering or give up on higher education completely. Outside of the academic areas, students may need other institutional support to help them function well in the learning environment. These resources can be efficiently accessed after students are advised of their existence and how they can be taken advantages of. Examples of support students may make use of include tutoring help, psychological and counseling services, legal services, health care professionals, mediators, and many others. Getting the students the help they need when they need it enables them to stay focused on their coursework while managing their daily lives better.

There are many models for how student advising can be accomplished. One example commonly encountered by students could be called punctuated equilibrium. This is where students are required to meet with specific advising staff or faculty at certain gate-keeper events like the transition from being a pre-engineering major to being in a specific major, the transition from lower division (freshman/sophomore) status to upper division (junior/senior), or advancement to graduation through a formal degree check. Students may or may not ever meet with an advisor during other times during their academic career.

Another model for advising could be called a single pass through approach. This is one where there are designated advisors for each academic rank, for instance one or two advisors for freshman, one or two for sophomores, etc. In this approach, students have the opportunity to engage with at least four faculty during their time as students, giving them a broader access to more viewpoints and expertise. One problem with this approach is that it is inefficient. Faculty/advising staff must spend time evaluating where each student is before moving on to the actual advising when they meet with a new advisor each year. Additionally, the advice may be the same that students have heard previously but then discovered did not help them; this is inefficient for both faculty and students.

A third mode of advising students is the least formal and could be called "catch as catch can". Students moving through a program organized around this theme do not have specific advisors for any point in their academic progress so they may not be able to get the help they need. They

may not even know who to ask for help in constructing their class schedule for core courses, leading to disaffection and loss of motivation to continue.

A final method of advising students is almost continuous and could be called "longitudinal advising". . One faculty/staff member is responsible for a student during their entire program of study at the university, leading to long term and sustained contact over time. Faculty in this model get to know the students well and can provide the most relevant advice as needed because they know the students' abilities, their weaknesses, and what works well for them. The intimate and close contact allows the faculty member to write much stronger and more specific letters of recommendation for students when they apply for positions, graduate school admission, or scholarships, as well. Students get to know one faculty member well and this can enable them to know the faculty more as a person than just an institutional representative. The strengths of longitudinal advising are enhanced when combined with situational leadership approaches[8] or developmental advising[9] approaches preferred by students[10].

This paper describes longitudinal advising of students, how it can be implemented through different contact points with students, and how it can lead to students being able to better control their own futures through self-determination. Motivating students is a strong focus, especially at critical points when many students may consider leaving engineering for other less challenging disciplines. The core set of skills that students must have upon graduation for success are then described, along with some subskills that may be conveyed for subdisciplines.

### **A Sample Department Where Longitudinal Advising Has been Implemented**

A few comments will be made about the department and the local environment where longitudinal advising has been done to highlight some of the characteristics that enabled this approach to be successful. The academic achievements and professional accomplishments of the students over the recent pass will also be highlighted to show the outcomes of this advising approach.

The chemical engineering department in this work has 14 faculty. These faculty members oversee one B.S. program in chemical engineering and M.S. and Ph. D. programs in both chemical engineering and environmental engineering. About 6 faculty members teach the 14 core B.S. chemical engineering courses and it is the B.S. population that will be the focus of the rest of the discussion.

All faculty members in the department are engaged in both teaching and research and there are no adjunct faculty who teach courses. The involvement of all faculty in all aspects of the department leads to more interactions among students and faculty. The student class size is about 55 at the sophomore level and between 30 and 40 students at the upper division junior and senior levels.

Core discipline courses are restricted to being offered only once a year and are fairly evenly spread over a 6 semester series. The hierarchical nature of the core courses mean it is critically important for students to work with an advisor to ensure they stay on track; deviation from the prerequisite courses delays student graduation by a full year in almost every case. One feature of

the program and course hierarchy is that once students begin their sophomore year, they will be with those same peer students until graduation. This makes it easier for faculty to track student progress and to follow different cohorts.

The student population in the chemical engineering B.S. program is very strong academically while also being diverse. Roughly 50 percent of each graduating class is female, which can be compared to the rest of the college being 18% female. This difference between chemical engineering and the rest of engineering is similar to those of other programs. About 85 to 95% of each graduating class is composed of domestic students. Forty-eight percent of the students are enrolled in the Honors Program at the university, which is about 3 times higher than the general student population with an 18% involvement. Out of each graduating class of 30 to 40 students, there will be 2 or 3 National Merit Scholars. Approximately 75% of each graduating class has done research in a faculty lab before they graduate. The students in the program are arguably the best in the college and university.

Student excellence in academic pursuits is evident at the local and national levels. At the college level, a chemical engineering student has been named the top student in the college 90% of the time, even though there are 18 different programs who nominate students each semester. At the university level, there are 10 or 12 students honored each year for being Pillars of Excellence, as selected by the Honors College. Out of the past 22 awardees, four have been chemical engineers. Also at the university level, three students in the past 6 years have been named the top undergraduate researcher in an internal competition. At the national level, students have been very strong in competition with other top chemical engineers at American Institute of Chemical Engineers conferences. In the last eight years, three students have been named as the best undergraduate researcher in poster competitions. It should be noted that the three national research awardees were not the same students as the local award, highlighting the depth of undergraduate research involvement. One student in the recent past was named the best chemical engineer in the country by AIChE after placing first in the oral competition at the national conference. Finally, students compete strongly at national level for scholarships and other awards. Four students in the past two years have been named Tau Beta Pi fellows and one was named the best engineer in the country as that organization's laureate. There have been numerous Udall scholars, NSF fellows, and one Fullbright award winner in the last three years.

Students compete strongly for both graduate school admission and for full time employment. One third of our graduates have consistently gone on to graduate school with about 95% of them going to Ph. D. programs that are ranked in the top 10 or 20. Students have gone to graduate school for degrees in chemical, biochemical, biomedical, mechanical, and environmental engineering. Students have also gone on for advanced degrees in pharmacy, mathematics, law, and medicine. On the job front, all but 1 or 2 students each year will have accepted an employment offer or graduate school offer by the day of graduation. Typically, the students without offers were not pursuing options or had U.S. visa issues.

Part of the success of our students comes from their diverse outside interests and their strengths in them, which are fostered by faculty members through longitudinal advising. In the past three years, graduating seniors have been leaders in many areas. One student was a Division I athlete who placed sixth at the PAC 10 track championships in high jumping. Another student was

named the best collegiate pianist at the university and then in the state, beating out M.S. and Ph.D. piano performance majors. One student routinely placed first or second in the American Tae Kwon Do Association's international weapons and hand-to-hand combat competitions. The Tour de Tucson is a 109 mile bicycle race that takes place late in fall semester, typically during a round of exams right before Thanksgiving. Three students have completed this race in the past three years, one of whom has cerebral palsy. Six students in the past three years have completed a marathon during the school year, two have completed full triathlons, and one third of the class two years ago completed the Tucson Half-Marathon. Students from the department have founded Engineers Without Borders, the Boxing Club, the Marathon Club, and the Table Tennis Club. On top of these students, approximately 1 single parent graduates each year.

Longitudinal advising is one of the mechanisms that allows the students to develop into the strongest candidates for their future endeavors and to achieve the successes just described. In addition, longitudinal advising eliminates many of the advising problems that students can create. This can help remove impediments to their progress through frequent major changing, often caused by students' difficulty in making long term decisions[11]. The sustained contact fosters long term and self-driven exploration by students. When longitudinal advising is not followed, students can attempt to "game the system" by shopping around for the advice they want. Students often move from advisor to advisor until they find one who will give them the answer they want, particularly in a department that has flexibility to treat special cases of students. This causes problems when students combine advice from several different sources about curricular issues, for instance, and try to create a plan of action that is inherently against the intentions of the faculty. An example may be replacing a core course with one from another department while also changing out another course that then leaves the student deficient in some of the content normally required to be mastered.

Another problem that longitudinal advising avoids involves hearsay or partial information. It is not unusual for students to partially remember some advising details from previous encounters with faculty and then misuse that partial information. Oftentimes, too, students turn to their peers for information and get poor advice on important decisions regarding their academic progress. Longitudinal advising helps ensure that the message is consistent because the messenger is the same each time the student gets help.

The ultimate goal of longitudinal advising in our department is to create engineering students who can self-direct their own career trajectories after their exposure to skills and tools that allow them to explore possibilities. The term "self-determination" is typically encountered in the context of countries and their right to determine internally, without outside influence, how to act. In this case, it means fostering self confidence[12] of students and exposing them to possibility. Discussions lead to an ability to self-direct that is the foundation of all other lifelong learning activities. The awareness students have of their own gaps in abilities and the possibilities they can achieve will guide them in their selection of new skill areas to build on throughout their lives.

It is good to point out here that advising is a pro-active way of building student's confidence by encouraging them to choose their own path and exploring their options. The role of advisor is to help students go not where the advisor has gone, and not where students' parents want them to go,

or not even where students think they should go. It is to help them break through any of these preconceived barriers to find what types of work they are passionate about.

Longitudinal advising involves several access points between students and the advisor that span a considerable length of time. Pre-college recruiting can be used to begin the dialogue, while freshmen events and formal advising appointments can build from there. As students transition to upper division courses, they can explore their courses and external activities with their advisor. Many schools will have some gatekeeper events where students must meet certain standards prior to advancement and will need to meet with an advisor formally at that point. These gatekeepers may have many names but typically come at the undergraduate education mid-point as students transition from lower division to upper division classes or at the end of their academic career for a senior degree check. There are also many other opportunities as students move towards graduation. Interactions between advisors and students, focusing on how to motivate students to explore their own trajectories will be discussed next.

Pre-college recruiting can be both formal and informal, ranging from meeting with students one-on-one to being large scale events with groups of students. Many high school students who have just completed their sophomore or junior years will travel with their families during the summer to explore universities, colleges, majors, and living conditions as they prepare to make their decision on where they will pursue their first degree. Interactions with these individuals are typically on a "drop-in" basis where the visiting families are directed to see an available advisor. More formal summer and academic year activities occur as well. These may include specific summer research institutes for pre-freshmen, outreach programs to local high schools, or mentoring programs with youth groups. Orientation events are another time when students formally meet with advisors to begin planning their academic program. Finally, recruiting dinners for special populations like underrepresented minorities or National Merit Scholars give other access points for advising.

Throughout the pre-college interactions, there are some strong foci for motivating students. One can question students about what they know about their potential major, addressing misconceptions and providing resources for them to explore the majors and opportunities. This is also a good point to begin assembling the background information about students that is critical to their success[13] and their families that will enable the advisor to work within that framework to select possible activities. Parents have strong influences on students' decisions[14] and knowing a student has a family where everyone has a Ph.D. in a discipline related to the student's choice is very different from knowing a student who is the first in their family to leave their small town to attempt a bachelor's degree. Rapport with students can begin to be built as advisors bridge their own experiences to what the students will soon be experiencing. Questioning the student about why they are choosing their major also allows the advisor to select appropriate exploration routes. If a student says they are choosing a discipline like engineering because they love math and its applications, then the advising can direct students to find independent research projects or summer programs where they will be exposed to these types of learning. Finally, a complete student background can be done by filling in information about the students academic background on grades, extracurricular activities, courses taken, and work experiences.



Freshman student advising tends to become more formal than pre-college interactions. There may be opportunities for access during a required freshman colloquium seminar series, through required courses, or through academic advising requirements[15, 16] for specific disciplines. Emails to students directing them to opportunities or to course requirements for prerequisites can help students get on track early for progress through their major courses[17]. There may be many self-sought interactions initiated by students, particularly those who are the most motivated. Course registration for an upcoming semester typically encourages students to seek out advice at that time. Some students will also find themselves on academic probation at the end of a semester and will need to formally meet with an advisor to come up with a plan to return to a successful trajectory. Motivational tools in cases like these are to discuss other students who have found themselves in academic distress who then went on to become successful in their endeavors. Exploratory activities may include finding the right expertise on campus to help students move past problems include seeing a psychological counselor, meeting with legal staff, or seeing evaluators for assessment of learning disabilities that may have emerged over time.

Advising activities designed to foster self-reflection and investigation of career pathways can be built directly into required courses. This is particularly useful when it is done consistently and is evaluated formally as part of the student's academic performance. Assignments that have been used to do this successfully include a one page essay where students describe why they are interested in their major and what aspects of possible careers interest them after a short lecture on the possibilities. Another activity involves a lecture on resumes, their content, and how to structure them to be concise and attractive, followed by an assignment requiring students to submit a resume for critique and scoring. This activity has been done at the freshman level to motivate students to begin filling in gaps in the core areas of work experience, leadership, and scholarship. Sophomores and juniors can also benefit from this activity as they move towards graduation when it will then become too late for any new development. At the senior level, this activity can be done a final time to ensure students have presented their skills the best way possible as they begin to apply formally for permanent positions. Another senior activity that is useful in times of economic downturn is to require each student to weekly submit a list of contact information and copies of cover letters they have prepared and sent out that week as a formally evaluated assignment.

In addition to career related activities, academic advising ones can also be built into core courses. One assignment used at the sophomore level involves explaining the criteria students must meet for advanced standing and progression to the junior core courses, then requiring students to report their completed courses and grades so they can self-assess their readiness for continuation. More informal interactions can also be used for discussing opportunities when faculty are also the academic advisor. The few minutes before and after class as students transition into and out of the classroom provides time for individual advising on issues that students face in their immediate future. Specific needs can be addressed on the spot or more formal dedicated time can be scheduled at that point if the issues are more complex. Interactions like these are one strong advantage of having faculty members also advise students.

Classroom contact with advisors is useful for identifying patterns in student behavior that may impede their success. Examples include addressing students who always put themselves down, students who lack confidence, or students who are shy and may need to be introduced to their

peers to begin interacting. Students who rely too much on team members for projects can also be identified and approached about how their actions may harm them over the long term. Students who have serious character flaws can also be addressed to help them find methods of mediating their flaw. Racism, sexism, and the inability to communicate have been successfully addressed informally and off-line out of the classroom after observing student interactions in the classroom.

Outside of the classroom, contact for motivating students can continue to occur as the students move towards graduation. Emails to course listserves or student organizations can direct students to applications for scholarships, opportunities for developing leadership skills, internships, and summer research programs. Connecting company recruiters with students who fit the desired skill sets can also foster development of student knowledge of their more immediate career options. Encouraging students to diversify their experiences and become involved is another strategy in helping them seek out new challenges that strengthen their portfolio.

A final academic requirement of a formal senior degree check is another opportunity to motivate students to examine their career trajectory. Typically, this evaluation occurs during the semester prior to students registering for their last semester's courses. Longitudinal advising should have prepared students to meet all graduation criteria at this point. However, students can still change their career path slightly through taking on an independent study project or by selecting electives appropriate for the careers they are interested in.

Graduation may not end all interactions between students and their past academic advisors. Students may continue to seek help in developing their career paths over extended periods of time. Students may request letters of recommendation for graduate school applications. Students may need help in resolving conflicts where students may want an outside view of their situation in order to sound out good routes for advancement. Students may want feedback on performance evaluations and how to handle criticism in a proactive way so they can select development opportunities. Encouraging continuing growth is possible with more longitudinal contact.

While past students may often want help, they are also a resource for faculty and their current students. Alumni can be contacted for help in placing students who are looking for internships or permanent employment, especially in cases where the past and current students share some common traits or connection. Past graduates can also be invited back into the classroom to hold discussions about their career paths as a motivational interaction. Connections over time can lead to donations of time, expertise, or money to the department through individual philanthropy.

### **Motivating Engineering Students and Retaining Them**

Motivating students appropriately is possible through knowledge of their academic and family backgrounds combined with a long term understanding of the career possibilities students have already explored through the choices they have made. Sometimes, students need more focused help when they are transitioning through a difficult phase in their lives. Students may find themselves in a new family situation through birth, death, divorce, or military service. Students may find themselves working to support themselves while pursuing their degree. Overcoming illnesses or accidents can also lead to academic struggles. Rising to challenges when failure

seems imminent can be fostered by sharing stories of students who have been successful after a circumstance similar to the one the struggling student is facing.

Engineering faces some special challenges in motivating students to stay enrolled. The coursework is often regarded as being the most rigorous and difficult on campuses. The large body of background knowledge needed to begin serious study of the core discipline eliminates many students from programs. However, the heavy courseload and academic requirements of being a full time engineering student can frustrate even the best students when they see their friends in other majors seemingly making high grades without a similar investment of effort or time.

Engineering offers some unique opportunities for motivation as well. The financial rewards of remaining in engineering over other disciplines, especially in difficult economic times, and the larger number of employment opportunities are a direct incentive for students. The constant and steady demand for qualified applicants from engineering is stable in both good and bad economic times. Students can be motivated by the intellectual challenge that not everyone can successfully complete the coursework while they have the satisfaction of progress. And, as social problems mount due to resource constraints, the ability to help others through their profession is another strong motivator.

There are certain core skills that students must have in a discipline in order to become successful. Fostering those skills can be done through longitudinal advising. It is assumed that graduates will be technically competent in their selected fields. However, students must have strong written and oral communication skills. These skills can be strengthened in students by suggesting they participate in writing workshops, become student ambassadors or tour guides, or through tutoring other students. Teamwork is another "soft" skill expected in students. Encouraging students to join clubs and move into officer positions over time allows them to build these skills in addition to any team based projects that may be required of students in the classroom. Through extracurricular activities students will also gain a better appreciation of how to learn independently, how to be flexible, and how to be persistent.

There are some gatekeeper assessments used for controlling student access to some opportunities after graduation. Students must have a resume for graduate school applications and permanent employment. A resume well populated with leadership activities in addition to relevant work experience helps candidates secure better offers. A strong GPA may also be needed for some possibilities like admittance to a highly ranked graduate program or receiving an offer from some companies that may have a 3.5 GPA requirement. Students who can demonstrate a good life balance through outside activities have advantages over other students. Longitudinal advising allows students to start with smaller activities and continually leverage their experiences into higher level interactions. One example is for students to become a general member of a club one year and then transition into a position with the officers of that club the following year.

For some disciplines, other gatekeepers include professional certifications students must fulfill. This may include passing the Fundamentals of Engineering exam or completing hazardous waste management training through OSHA, among others. Any activities students can do ahead of time to prepare for their successful completion of these other demands will make them more

attractive for hiring. Longitudinal advising allows information about all of these topics and their importance to be shared with students when they still have time to enhance their development.

### **How to Create Opportunities for Longitudinal Advising**

Much time has been spent discussing the benefits of and how to implement longitudinal advising in the framework of undergraduate experiences. The discussion will now turn to how longitudinal advising can be encouraged at the departmental or institutional level. One recommendation is to assign pre-majors or freshman directly to one advisor who they will be engaged with as soon as they have contact with their major, possibly even prior to students seeking out help. This advisor would then remain their advisor until they complete or leave the program. Another recommendation is to only have advising by those faculty or staff who are passionate about this activity. A mediocre to poor advisor who followed a student longitudinally could do more damage to student motivation than a short interaction with a good advisor can compensate for.

Department heads and curricular chairs can foster connections between faculty and advisors if they are not the same people by hosting short meetings oriented around sharing information. Advising deadlines and methods of fostering self determination within students as discussed previously in this work can be shared with faculty to be incorporated into courses. Faculty members, in turn, can provide a list of concerns students have voiced about issues relevant to them, or can help in identifying those students who may face special challenge so advisors can follow up. Professional staff who have contact with students could also be included in this meeting. One meeting perhaps once a semester would allow for contact and sharing of this information.

At the college and university levels, adequate training and exposure to student resources should be provided to all advisors[18]. A single pamphlet that organizes all support offices like disability resources, tutoring, counseling, etc., could be provided at the beginning of each year to remind faculty of their existence in a concise place. Release time from other service duties will also enable faculty and staff to provide the best in advising services longitudinally. Recognition of accomplishments in this service arena will reward faculty for the patience and determination to help students in reaching their highest levels of achievement.

### **Conclusions**

Longitudinal advising is a way of consistently motivating students to reach their highest potential. One plants the seeds of ideas that may grow fruit over time through exposure to new skill areas or information. Students can learn how to be flexible through evolving interactions with their advisor when they adapt to students' changing needs. Impediments to personal growth can also be removed when they are small or manageable. The sustained interactions over long periods of time allow advisors to know the students well and help them transition to lifelong learning professionals who are successful.

## References

1. Seldin, P., *Evaluating Faculty Performance: A Practical Guide to Assessing Teaching, Research, and Service*. 2006, Bolton, MA: Anker Publishing.
2. Link, A.N., *A time allocation study of university faculty*. *Econ. of Educ. Rev.*, 2008. **27**(4): p. 363-374.
3. Mitchell, T.R., *The academic life: Realistic changes needed for business school students and faculty*. *Acad. Manag. Learning Educ.*, 2007. **6**(2): p. 236-251.
4. Kuhn, T., Padak, G., *Is academic advising a discipline?* *NACADA J.*, 2008. **28**(2): p. 2-3.
5. Collins, M.A., Zinskie, C. D., Keskula, D. R., Thompson, A. L., *Institutional responsibilities and workload of faculty in baccalaureate dental hygiene programs*. *J. Dental Educ.*, 2007. **71**(11): p. 1403-1413.
6. McCormick, C.B., Barnes, B. J., *Getting started in academia: A guide for educational psychologists*. *Educ. Psych. Rev.*, 2008. **20**(1): p. 5-18.
7. Balogun, J.A., Sloan, P. E., Gemain, m., *Core values and evaluation processes associated with academic tenure*. *Perceptual and Motor Skills*, 2007. **104**(3): p. 1107-1115.
8. Lerstrom, A.C., *Advising Jay: A case study using a situational leadership approach*. *NACADA J.*, 2008. **28**(2): p. 21-27.
9. Huggett, K.D., *Advising in Undergraduate Honors Programs: A Learner-Centered Approach*. *NACADA J.*, 2004. **24**(1&2): p. 75-87.
10. Smith, J.S., *First-Year student perceptions of academic advisement: a qualitative study and reality check*. *NACADA J.*, 2002. **22**(2): p. 39-49.
11. Frimin, M.W., MacKillop, L. M., *Frequent major changing: Extrinsic and intrinsic factors*. *NACADA J.*, 2008. **28**(2): p. 5-13.
12. McDonald, M.L., *Advising high-ability business students*. *NACADA J.*, 2003. **23**(1&2): p. 58-65.
13. DesJardins, S.L., Jie, W., *An analytic model to assist academic advisors*. *NACADA J.*, 2002. **22**(1): p. 32-44.
14. Simmons, A.N., *A reliable sounding board: Parent involvement in students' academic and career decision making*. *NACADA J.*, 2008. **28**(2): p. 33-42.
15. Sams, W.P., Brown, L. S., Hussey, R. B., Leonard, M. J., *The development, implementation, and assessment of a systematic academic advising program for exploratory first-year students*. *NACADA J.*, 2003. **23**(1&2): p. 75-85.
16. Gordon, V.N., *The Evolution of Academic Advising: One Institution's Historical Path*. *NACADA J.*, 2004. **24**(1&2): p. 17-23.
17. Schwebel, D.C., Walburn, N. C., Jacobsen, S. H., Jerrolds, K. L., Klyce, K., *Efficacy of intrusively advising first-year students via frequent reminders for advising appointments*. *NACADA J.*, 2008. **28**(2): p. 28-32.
18. Waters, T., *Faculty socialization into the advising role: An examination of information and information sources that shape role learning*. *NACADA J.*, 2002. **22**(1): p. 15-25.

## Biographical Sketch

Paul Blowers received his PhD from UIUC in 1999 and has been a professor in chemical and environmental engineering at the University of Arizona since that time. He has been recognized as a top educator at the departmental and regional levels and in the past year was recognized as the best faculty academic advisor at his institution. He then went on to be selected as one of the top four faculty advisors in the U.S. by the National Association of Academic Advisors.

## **Distance Learning and Cognitive Load Theory to Enhance Computer Programming for Mechanical Engineers: Qualitative Assessment**

Thomas J. Impelluso, Ph.D.  
Associate Professor  
Mechanical Engineering  
San Diego State University

### **ABSTRACT**

A computer programming class for students of mechanical engineering was re-designed with regard to both content and delivery. The goal was to improve student learning attitudes. Cognitive Load Theory (CLT) was used to re-design the content; on-line technologies were used to re-design the delivery. Since the targeted students were not computer scientists, the course was re-designed to focus on computer programming examples used in mechanical engineering. Scaffolding was used to integrate syntax elements with each other, algorithms with each other, and, the algorithm to the syntax. The effort was assessed using student attitudinal data. The effort confirmed the utility of CLT in course design, and it demonstrated that hybrid/distance learning is not merely a tool of convenience, but one, which, used purposefully, inspires students to learn.

### **Introduction**

Cognitive Load Theory (CLT) provides guidelines to present information in a manner that encourages learning and optimizes intellectual performance [1]. As an example, consider the obstacles in learning new material in a non-native language. Clearly, there is an overload: learners must master the new material and the language itself. Interestingly, this is resonant with the challenge of learning to program a computer (learners must master operating systems and the syntax) for students not in the computer science major. CLT can mitigate challenges in such cases when learning loads are high. CLT was used to re-design a computer programming class for mechanical engineers at San Diego State University.

According to CLT, information can only be stored in long term memory after first being properly integrated, by working memory, into a mental structure that represents the schema of the material. However, the faculty of working memory has limits and this, unfortunately, can hinder learning, especially when many extraneous facts compete to challenge the cognitive learning loads (which, in the case of programming, encompass text editing, operating systems and compilers). CLT posits that there are three basic types of cognitive loads placed on a learner:

- “Intrinsic cognitive load” was first described in 1991 [2] as the essential material to be learned. Accordingly, all instruction has an inherent difficulty associated with it and

this intrinsic material may not be altered by an instructor. In learning a foreign language, this includes the vocabulary and syntax.

- “Extraneous cognitive load” is generated by the manner in which information is presented to learners [3] and, in the case of a programming language, the ancillary information such as text editors, compilers and operating systems. Or, in the case of a spoken language, the technologies such as language labs or voice recordings.
- “Germane cognitive load” was first described by Sweller, van Merriënboer, and Paas in 1998 [4]. It is that load devoted to the processing, construction and automation of schemata necessary to integrate knowledge into consciousness. This includes motivations to learn and how the knowledge is situated in the rest of the curriculum such as reading novels, or programming mathematical algorithms.

These three loads are additive in the learning process and research suggests [4] that when courses are redesigned with due respect paid to the interaction of cognitive loads, learning is improved. For example, while intrinsic load is generally thought to be immutable, instructional designers can exercise the option to manipulate extraneous and germane load. With complex material, it is best to strive to minimize the extraneous cognitive load and maximize the germane load.

**Table 1**

**The Three Types of Cognitive Loads Placed on Learners of Computer Programming**

<b>Load</b>	<b>Examples</b>
Intrinsic	Syntax: data types, loops, logical tests, arrays, functions
Extraneous	The complex interplay between syntax, text editor and operating system
Germane	Numerical Algorithms in Computational Mechanics

Table 1 presents this author’s view of the various learning loads experienced in computer programming. The intrinsic learning load is high in computer programming. Thus, if one also employs methods that add an extraneous load (such as complex compiler interfaces), it is very likely that there will be little capacity left for germane load that might be used to motivate students of mechanical engineering to learn programming; and the ensuing overload would then hinder their learning.

Furthermore, it has been shown that complete, thorough, and fully commented programming examples provide greater motivation for novices than simply working out problems from scratch [5][6]. Although this may seem counterintuitive, tests have demonstrated that studying complete examples facilitates learning more than actually solving the equivalent problems [7]. Additionally, in many cases, a variation of worked examples balanced with assignments was used [8]. Students can be urged to *complete* the solution, which is only possible by the careful study of the partial example provided in the completion task. And like providing completely worked examples, this serves to decrease extraneous cognitive load [9].

Finally, the necessary ingredient to enhance the germane mode is through scaffolding. Scaffolding became an essential ingredient in this course re-design. And this approach is supported by existing research that has been successfully applied to the domain of computer programming [10].

## **2. Course prior to re-design**

### **2.1 Course content**

The course under discussion is SDSU: ME203 – Programming. In this class the C programming language is taught in a UNIX environment. The course presents a *procedure oriented* language (as opposed to *object oriented* language such as Java or C++), because mechanical engineers are more concerned with the *process* of applied mathematical algorithms (solids, fluids, thermal studies) than with *objects* to be manipulated (computer graphics, bioinformatics). Of the procedure oriented languages (e.g., C vs. FORTRAN), C was selected because it is the language in which most operating systems are written.

The focus of the class was on the syntax of the C language. Advanced syntax techniques such as ‘data structures’ were taught. Secondary attention was paid to the Gauss Reduction method and various algorithms to multiply matrices. Mechanical engineering coding examples were not integrated into the course; they were presented without instructional design forethought.

### **2.2 Course delivery**

Prior to Fall 2006 the class met physically and the exclusive method of content delivery was through face to face lecture. Instruction was provided in a workstation laboratory. This laboratory was a dedicated computational resource cluster of 30 UltraSPARC models 170 and 170E workstations using the Sun Grid Engine software from Sun Microsystems. Each station in the cluster had 128MB of physical memory, and contained one 167MHz US-I CPU. The workstations were interconnected using high-speed network infrastructure from Myricom.

The instructor taught at one workstation and displayed his monitor on an overhead projector. Students were able to watch the instructor discuss the code line-by-line, compile it, and run it. Then, students would work on their own code in a separate lab session. This model of instruction had weaknesses. First, the size of the class was limited to the number of workstations. Furthermore, the workstations had to be upgraded every few years at considerable expense. Third, the students often expressed frustration as to why they were learning the material. Student reviews consistently mentioned that there was no reason for mechanical engineers to learn programming. Thus, course re-design was initiated.

## **3. Course after re-design**

### **3.1 Course content**

Two levels of course material were scaffolded by themselves and with each other: 1) the syntax of the language (data types, loops, logical tests, arrays and functions), and 2) the applied mathematical algorithms (vector, matrix manipulation, Gauss Reduction and Newton-Raphson methods). The purpose of the scaffolding was to avoid previous student criticisms of seeing no purpose to learning programming. The scaffolding more tightly connected the syntax to the algorithm and gave purpose to the class for mechanical engineers.



### 3.1.1 Vertical Scaffolding

The left column of Table 2 indicates the *syntax structures* that were discussed in the class. Complete and commented code syntax examples were scaffolded on the skeleton of preceding ones: loops were discussed in the context of logical structures, and arrays were discussed in the context of loops. The right column indicates the *mathematical algorithms* that were discussed in class: Complete and commented algorithms were scaffolded on previous ones. Thus, Newton-Raphson relied on the Gauss Reduction code; Gauss-Reduction relied on matrix manipulation and matrix manipulation relied on vectors. The same code “grew” and “evolved” in each example.

**Table 2**  
**The Scaffolding of Algorithm and Syntax After Redesign of the Course**

<b>Algorithm</b>	<b>Syntax</b>
Temperature Conversion	Data types and logic
Bisection Method	Logic & loop formality
Newton's Method	Logic & loop formality
Numerical Integration	Logic & loop formality
Repeat of all previous algorithms	Input/Output
Matrix-Vector Multiplication	Arrays
Gauss Reduction	Arrays, files
Gauss reduction with functions	Arrays, files functions
Newton Raphson Method	Arrays, files, functions, memory

### 3.1.2 Horizontal Scaffolding

The driving focus of the content in this class was the algorithm rather than the syntax. Thus, this inverts the way programming has traditionally been used in which syntax rules are presented and are the focus – as often happens when programming classes are farmed out to computer science departments. Furthermore, there were no coding examples of sorting, alphabetizing, or interest rate problems that plague introductory computer programming courses for mechanical engineers.

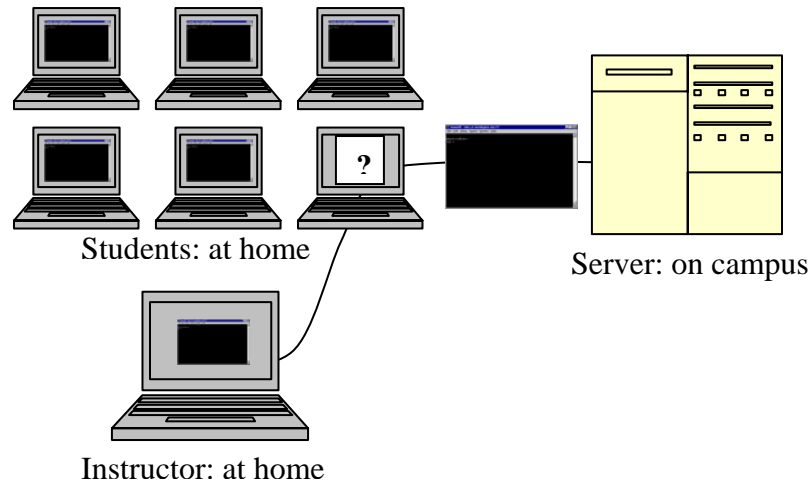
Table 2 indicated the algorithms in the first column, followed by the programming syntax in the second. Vertically, the table demonstrates the order in which both topics were addressed. It is important to note that numerical algorithmic convergence and stability issues were ignored, in lieu of the most simple algorithm implementation. This table also demonstrates the horizontal scaffolding that occurred in the class. By connecting algorithm to construct, the re-design enhanced the germane load of the student learners.

The instructional goal was to challenge the students to read codes as if they were a new language. It was not expected that the students master the code's nuances and reproduce them at this stage. Rather, the goal is to immerse the students in a new language and expect them to follow the general idea of how the language implements the logic of a simple game.

Next, the course delved into a series of code examples involving matrix manipulations. And finally it moved on to the two core concepts of the course. In fact, students were often reminded that these two algorithms were the core algorithms in mechanics. The Gauss

Reduction is the algorithm to solve a system of linear equations, while Newton-Raphson is for a system of non-linear equations; both are critical components in mechanics-based Simulation Science. However, there is serendipitously something more profound which was exploited here: the Newton-Raphson method builds upon the Gauss Reduction method. This creates an overarching structure to the class as it drives toward the study of very simple non-linear systems.

### 3.1.3 Course Delivery



**Figure 1. Student-instructor connections for online class sessions.**

With regard to delivery, two modes were used in equal parts: 1) face to face, and 2) interactive, on-line application sharing. Half the classes were face-to-face, and this is where algorithm and syntax were taught. Extensive PowerPoint slides were developed and they were tied to each item in Table 2. Face-to-face lectures focused on the interplay of intrinsic and germane learning loads.

The extraneous learning load was obviated by use of on-line instructional technologies. However, this was not a passive use in which students simply observed lectures. Application sharing technology was used – the instructor took control of student laptops as if working with the student, side by side, while also demonstrating the effort to the rest of the class. The schematic for an on-line session is indicated Figure 1. Students were able to work on their assignments from home (during or after class lab-time), regardless of their operating system, by first establishing a terminal SSH session to the server on campus using a monitor prompt. Once connected to the server machine, students are able to write, compile, and debug their codes.

The instructor also maintained an SSH connection to the same server and exploited the application sharing interface of Wimba. The instructor shared his desktop (which contains an SSH connection to the server) with the class and demonstrated the process of writing, compiling, debugging, and running example codes. Occasionally, whether during a class session or during “office hours,” a particular student would request assistance with an assignment (indicated by the laptop with the “?” mark and his SSH connection by the largest black monitor window external to his laptop). At those times, the instructor activated the Wimba application sharing interface and asked the student to share his/her desktop with him and the rest of the class. Then, the

instructor addressed the student's questions, while also sharing the information with all of the students.

Special note is made of the fact that all the students in the class used the same operating system on which to compile and run their code examples. This minimized a great deal of confusion for the students: they used an SSH tool to connect to the common server on which they all studied and learned. This summary warrants focused reiteration. Extraneous learning loads were lessened by on-line, desktop sharing; these learning experiences demonstrated code writing and compiling, interactively. The instructor, at home, used Wimba to pass through the workstation of the student (also at home) and continued on to the student's account on the server (on campus), fixing the code and sharing the lesson with sixty other students (also at home). The instructor then archived the session, which enabled other students to play it back at their leisure. In this way, students were able to observe codes being written, edited and recompiled. Also, all the writing and compiling occurred in a common workstation environment, unencumbered by the nuances of diverse compilers. This consistency – this common computational environment – reduced the extraneous load of learning operating systems, compilers and text editors; students were able to focus attention on the syntax of the language and the mathematical algorithms.

#### 4. Attitudinal Assessment

This course was subjected to qualitative student reviews. The same instructor has taught this class for ten years; thus, any improvement in assessment that resulted from the re-design cannot be attributed to recent mastery of the material. Two assessment periods are provided. Fall, 2006 assessments were for the class before there was any re-design. Spring, 2008 represents the first semester in which the instructor gained facility with the instructional technology and the modified curriculum.

Students were asked to respond to this question: *What are your comments/suggestions for the course?* Naturally, this paper cannot provide all responses, so random responses were selected from the fall, 2006 semester and are presented in Table 3. Responses from the spring, 2008 semester are presented in Table 4

**Table 3**  
**Fall, 2006 Responses to Qualitative Questions Concerning the Course**

hard to understand
For a course that is comparable to learning a foreign language in a matter of 15 weeks, not only was it hard to adapt to but the professor made it even more difficult by making it hard to ask questions.
Try to make subject more interesting
it seems to be an unnecessary class for mechanical engineers

The previous responses were mostly negative and the few positive responses were apathetic. After the re-design, the negative responses became more active in suggesting improvements while the percentage of positive responses increased and became more vigorous.

**Table 4**  
**Spring, 2008 Responses to Qualitative Questions Concerning the Course**

More examples of real world application, shorter classes, keep this direction going!
i felt that this course didn't teach me how to write programs only a few key algorithms. I feel that the course should be more focused on the coding and not the algorithms
NO MORE ONLINE CLASSES, I PAY MY TUITION TO LEARN FROM A HUMAN NOT A COMPUTER!!!!!!!!!!!!!!
This is an excellent introductory course in programming for any non computer engineering student. I think the structure of the exams should be changed; I think the exams should be more like project-oriented.
This is a great course overall, but there has to be a class before this at least to show us how programming works; to teach us the basics of programming and getting familiar with it. This course just jumps ahead and you can fall back very easily.
go a little slower in the beginning, since that's the most important part

Clearly, this re-design has excited the students. Enrollment has increased. Students took a more active part in their learning. They offer advice on how to improve the class, and, this, in turn, makes it easier to continually improve the course through consistent re-design.

Students were then asked to respond to this question: *What are your comments, positive or negative, on the instructor's teaching?* Again, random responses were selected from the fall 2006 semester and are presented in Table 5. Responses from the spring, 2008 semester are presented in Table 6.

**Table 5**  
**Fall, 2006 Responses to Qualitative Questions Concerning the Instructor**

Dr. I came off as the least approachable professor i ever had causing communication problems which led to a tear in his teacher/student relationship.
Moves much to fast through the course material. Maybe it's because there is too much material for the course, but it needs to be slowed down.
I wish he would explain what he is doing a little more clearly. He can breeze right through an area expecting us to know what he is talking about.
Answer peoples questions with out making them think that they are stupid. Usually people who are in engineering are not stupid so treat them with respect.
Teacher was not able to stimulate interest. Unable to fully/clearly explain the material.
negitive, everyting i learned was from the internet

**Table 6**  
**Spring, 2008 Responses to Qualitative Questions Concerning the Instructor**

He moves a little fast but if you ask him to slow down he will. You can ask any question no matte how dumb and he will answer it over and over again until you get it. Very helpful
He goes out of his way to keep students active in the class which is rare in a teacher.
Very helpful teacher and clearly taught the material
Instructor goes above and beyond the call of duty.
The instructor was always available for the students and was very flexible about helping out students.
Dr. Impelluso is the most accessible, straightforward, fair teacher that I have ever had in my life. He fully employs every method possible to teach us, including blackboard, a separate class website, wimba 'liveclassrom' and archives, powerpoint and word outlines, emails on a regular basis, in-classroom instruction, and was even very active on the discussion board. I do not doubt that he spent more time on this class than I did on all of my classes combined. He made every effort (and I mean every) to keep his grading scheme fair. If a single person expressed their confusion with a topic, he made it a point to comprehensively review the topic during the following class. I feel like I learned a lot about what the next steps in programming and engineering look like, and am very interested to continue to pursue these fields

as a career.
Dr. Impelluso extends himself above and beyond to help his students. However, his lectures seem to change focus abruptly which leaves the student lost.
The vocabulary for the course makes it difficult to ask questions. It is new so I didn't know how to formulate questions and Impelluso is not aware or not sensitive enough to this. I really like the fast response time in email. I really appreciated the extra time and effort and caring about students that he put into this class. Impelluso stressed too much on how students were doing and made himself too available to students, resulting in him stressing and getting upset. I suggest setting up office hours but holding them online or by individual appointment only and make help more the students responsibility. good teacher. I love it when teachers care, it helps and motivates, so thank you, overall I give you an above average for teaching, most don't care, especially those with tenure, is that how you spell it? Thanks!!

## 5. Discussion

### 5.1 Cost Savings

As a result of this new foray into distance learning, the workstation cluster once used to instruct the class in exclusive face-to-face lectures is no longer needed. This has already amounted to nearly \$40,000 in savings to the department. Furthermore, the distance delivery has enabled the class to overcome the enrollment limitation dictated by the available workstations. Enrollment has progressed from under 30 students to now over ninety in one session, obviating the need to hire a lecturer to support additional sections. As of this writing, the original laboratory has been removed and the space is now utilized for other classrooms.

### 5.2 Plateau Instruction

The author of this paper engaged students in several personal discussions about their learning experiences and these are summarized herein. This section is entirely anecdotal, very personal, and without reference to the literature. It reports on feelings and thoughts expressed by students.

It seems that students are able to approach their high school studies in a disintegrated way. Consider Biology: the material and the textbooks are cleanly segregated; information is sequentially presented on the digestive system, the cardiac system, the muscular system, the nervous system, and the skeletal system. Students are quite capable, they tell the author, of mastering one system, failing another, and still securing high grades in the end. The same can happen in high school literature classes (authors are disintegrated), and physics (kinematics, thermal studies, optics, and nuclear studies).

Many of the students verbally shared their feelings that they never expected the course to stack the way it did and they attributed this to their poor performance. And this justified the introduction of the two mid-semester review periods conducted in the class. The instructor stopped all progress in the class and reviewed all material. Rather than consider this a simple review period, placing an onerous burden upon the instructor, the instructor now considered this to be a "plateau" experience, wherein no new material was presented. This enabled students who underestimated the course to catch up and not suffer penalty.

### 5.3 On-Line for a purpose

SDSU has a policy that a course is “hybrid” if 45% of instruction occurs on-line. This compelled the course designer to initially hold physical sessions (55%) and on-line sessions (45%) indiscriminately and one after the other. In the second roll-out, however, the instructor began using the on-line sessions for laboratories to diminish extraneous load. The author advises adopters of distance learning to seek out which aspects of a course are suitable for distance learning and deploy those first.

## 6. Conclusions

Distance technologies have changed since they first emerged – they are no longer passive technologies which simply enable download of content; they now enable interactive learning. This course re-design made use of these latest technologies, specifically including desktop sharing. The redesign was guided by CLT. CLT has been demonstrated to be a useful schema for re-designing a course. Three types of scaffolding have been deployed: vertical and horizontal (scaffolding intrinsic learning loads) and temporal (scaffolding germane learning loads). Distance technologies were used to minimize extraneous learning loads.

The re-design resulted in a tremendous cost savings to the department. Student perceptions and motivations have dramatically increased. It is noted that that author chose to use increasingly more difficult exams to ensure equity in grading and to prevent grade inflation. In future work, the author will shortly revert back to exams from years past and report on the results. It is expected, however, that the majority of the students will excel.

Can this design and implementation impact other classes in mechanical engineering; specifically, in courses which teach programming interfaces such Computer Aided Design software? Yes, provided that an aspect of SSH is addressed. The difficulty with SSH is that it is text-based: a *graphics* application running on a remote server cannot be displayed on the local “student” client. X-Win, however, enables graphics codes to be displayed remotely. X-Win32 is StarNet’s latest X terminal application for Windows and Mac clients. X-Win32 allows Windows users to connect to Linux/Unix servers on a network and run the applications from those servers on their Windows desktop. This spring (2009), Xwin-32 will be deployed in the class so that students can instantiate a simple graphics code.

This has further implications for distance learning in engineering, for it will enable universities to exit the computer infrastructure support business. Universities can load visualization software on a server, enable the students to download XWin, and run the codes on the server, yet display them at home. Advanced visualization tools can now be fully deployed in all aspects of a curriculum, while still using distance learning tools. For once, universities can exit the hardware infrastructure support business and go so far as to invert pedagogies by exploiting 3D simulations with distance learning in all aspects of a curriculum.

## REFERENCES

- [1] Sweller, J. 1994. Cognitive load theory, learning difficulty and instructional design. *Learning and Instruction* 4: 295-312.
- [2] Kalyuga, S., Chandler, P., and Sweller, J. (1998). Levels of expertise and instructional design. *Human Factors* 40, 1-17.
- [3] Pollock, E. Chandler, P. and Sweller, J. (2002). Assimilating complex information. *Learning and Instruction*. 12(1), 61-86.
- [4] Sweller, J., J. Van Merriënboer. and F. Paas. 1998. Cognitive architecture and instructional design. *Educational Psychology Review* 10(3): 251-296.
- [5] Renkl, A., and R. Atkinson. 2003. Structure the transition from example study to problem solving in cognitive skill acquisition: A cognitive load perspective. *Educational Psychologist* 38(1):15-22.
- [6] Renkl, A., R. Atkinson, and C. Grosse. 2004. How fading worked solution steps works – A cognitive load perspective. *Instructional Science*: 59-82.
- [7] Van Gerven, P., F. Paas, J. Van Merriënboer, and H. Schmidt. 2002. Cognitive load theory and aging: Effects of worked examples on training efficiency. *Learning and Instruction* 12: 87-105.
- [8] Van Merriënboer, J., and F. Paas. 1989. Automation and schema acquisition in learning elementary programming: Implications for the design of practice. *Computers in Human Behavior* 6: 273-289.
- [9] Van Merriënboer, J., J. Schuurman, M. de Croock, and F. Paas. 2002. Redirecting learners' attention during training: Effects on cognitive load, transfer test performance, and training efficiency. *Learning and Instruction* 12: 11-37.
- [10] Van Merriënboer, J. 1990. Strategies for programming instruction in high school: Program completion vs. program generation. *Journal of Educational Computing Research* 6(3): 265.

## BIOGRAPHICAL SKETCH

Dr. Impelluso received his BA in Liberal Arts from Columbia University. This was followed by two MS degrees in Civil Engineering and Biomechanics, also from Columbia. He received his doctorate in Computational Mechanics from the University of California, San Diego. Following this, he worked for three years in the software industry, writing code for seismic data acquisition, visualization, and analysis. He then commenced post-doctoral studies at UCSD, wherein he secured grants in physics-based virtual reality. He is now a tenured associate professor at San Diego State University, revisiting and researching human bone remodeling algorithms and muscle models using advanced tools of the cyberinfrastructure. He has created a curriculum in which students learn mechanics not by using commercial simulation software, but by creating their own. His interests include opera, sociology, and philosophy. He is currently enjoying teaching his two young children how to ride bicycles.

## FUNDING AND SUPPORT

(This work was supported by two grants.)

### Multi-Phase Mechanics

**Agency:** NSF

**Amount:** \$124,550

**Duration:** 11/05—11/06 (plus one year no-cost extension)

**Summary:** Extend a platform for solution of multi-phase problems by incorporating non-linear interaction and contact with extension year duties of curricular deployment.

### Dissemination of a New Mechanical Engineering Curriculum

**Agency:** FIPSE

**Amount:** \$370,000

**Duration:** 9/02—9/05 (plus two year no-cost extension)

**Summary:** This project funded the evolution and dissemination of a method to teach mechanical engineering at its intersection with computer science.

## ACKNOWLEDGEMENTS

The author thanks Suzanne Aurilio and SDSU's pICT for providing valuable assistance with this course re-design.

**A Junior Level FPGA Course in Digital Design  
Using Verilog HDL and Altera DE-2 Board  
For Engineering Technology Students**

by

Tariq Qayyum

Associate Professor  
Engineering Technology Department  
California Polytechnic University  
Pomona, California  
[tqayyum@csupomona.edu](mailto:tqayyum@csupomona.edu)



## Abstract

This FPGA course is designed for junior level students who are pursuing a baccalaureate degree in electronics and computer engineering technology. Exercises were adapted for use of the Altera DE-2<sup>6</sup> development board, which were donated by Altera cooperation. Software used was Quartus II, which is freely available from Altera website. The board was found to be useful and student-friendly for majority of the laboratory exercises and for simple design projects.

## Introduction

Use of a hardware description language, such as VHDL or Verilog to program a programmable logic device, has become very common basis for digital design laboratories. The programmable logic devices themselves have become capable of handling greatly increased amounts of logic, allowing more and more complex design to be programmed into more and more affordable logic devices. These programmable devices are capable of handling many inputs and can produce several outputs. The course, which was taught, was based on both combinational and sequential logic design.

## Software Installation on PC<sup>1,6</sup>

The Quartus II software is freely available from Altea website, for the laboratory use a license was acquired through Altera university education division. Following are the steps to download software from Altera website:

- Go to Altera website and click on software download
- Click on Quartus II Web Edition<sup>1</sup> Software
- In order to successfully download, fill out the form submit the request for downloading
- Once the form is filled out, it should lead to the download manager page. From there determine where you want to save the installation file.
- Once the download is complete, launch the Quartus software and follow the steps provided from the wizard
- After the software has been is installed successfully, a license file is required to run. This license file could be obtained from Altera website<sup>1</sup>. To install this file follow these steps:

1. Go to start ⇒ Run
2. Type *cmd* or *command*
3. Type *ipconfig/all*
4. Write MAC address of the Ethernet adapter
5. Go to Altera site and click on licensing and follow the steps
6. A license file will be e-mailed to you
7. Save that file in Quartus folder
8. Now you are ready to use Quartus software

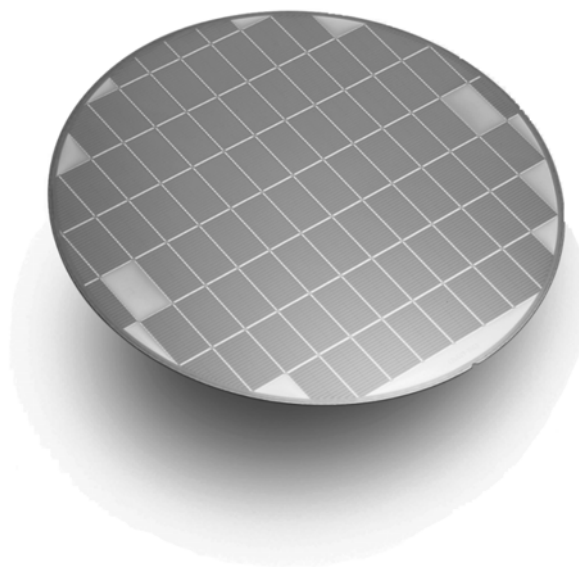
## Designing Combinational and Sequential Circuits

The Quartus II software provides three options for designing circuits;

- Schematic capture
- Using VHDL
- Using Verilog HDL

For this course, Verilog HDL was used to design logic circuits. Detailed instructions were provided to students about creating source files, using Altera DE-2<sup>6</sup> board, compiling source file, making pin assignments for *Cyclone II EPC35F672C6* device, and downloading compiled file to the Altera DE-2 board.

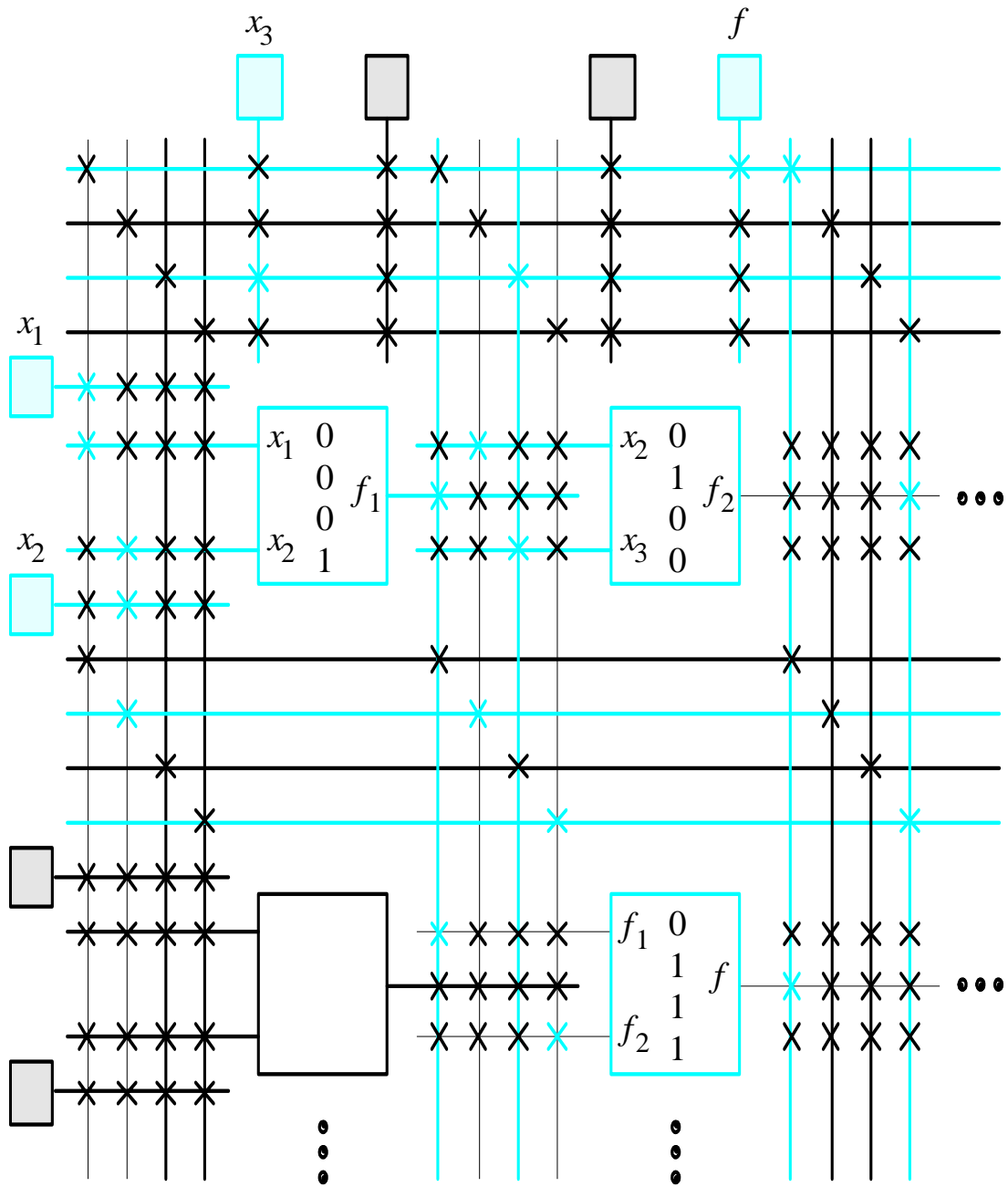
## FPGA Structure



**Fig 1: Silicon Wafer** <sup>2</sup>

	Year					
	2006	2007	2008	2009	2010	2012
Technology feature size	78 nm	68 nm	59 nm	52 nm	45 nm	36 nm
Transistors per cm <sup>2</sup>	283 M	357 M	449 M	566 M	714 M	1,133 M
Transistors per chip	2,430 M	3,061 M	3,857 M	4,859 M	6,122 M	9,718 M

**Fig 2: Silicon Technology Evolution** <sup>3</sup>



**Fig 3: Internal Structure of a Programmed FPGA** <sup>4</sup>

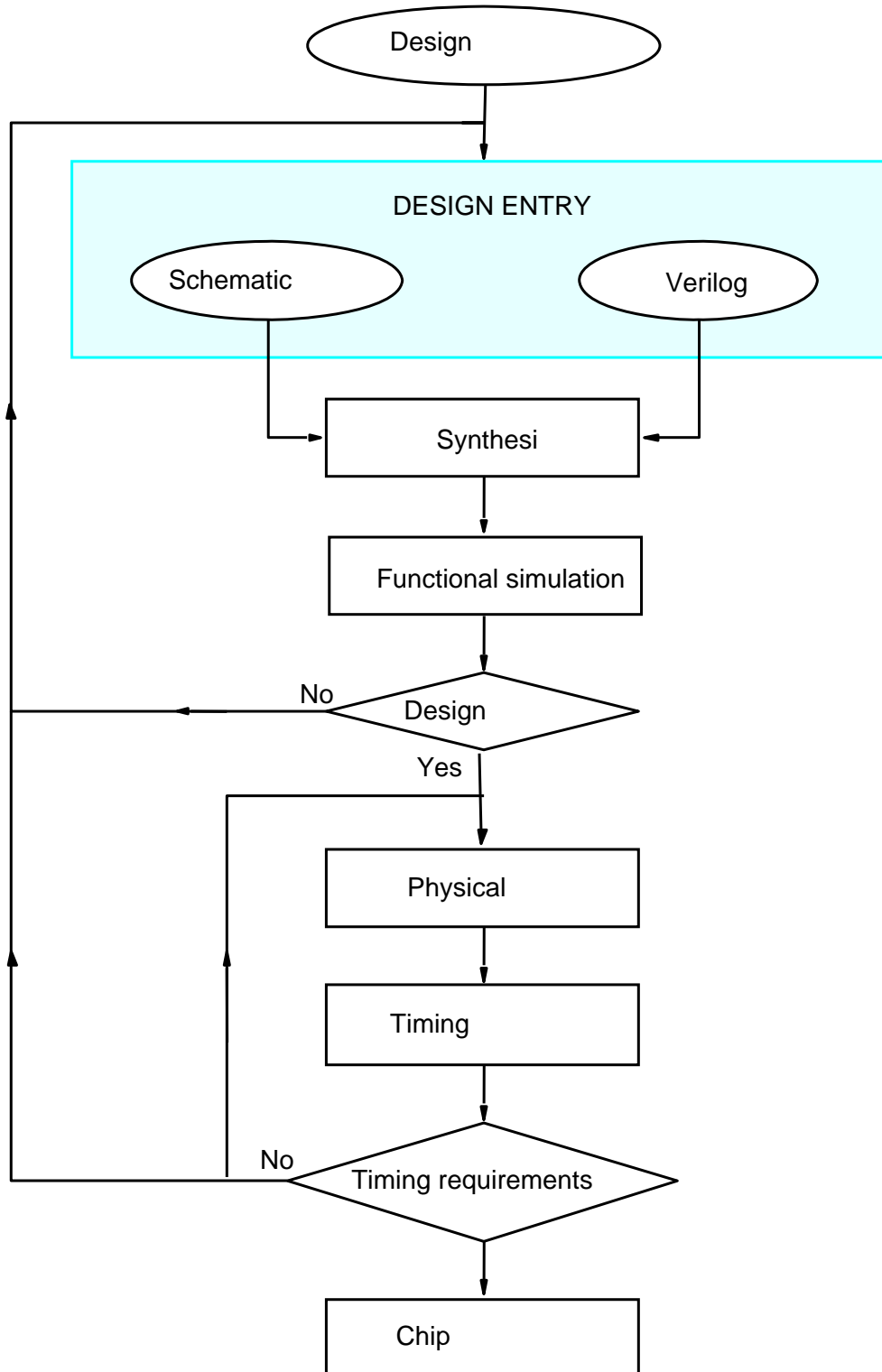
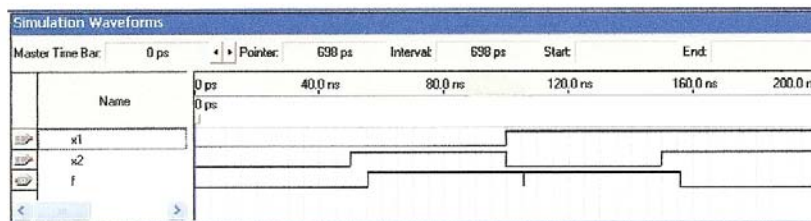
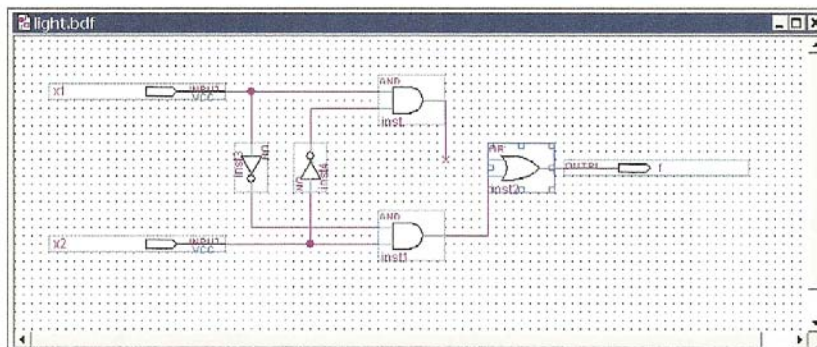
**Fig 4: A Generic Design Flowchart**<sup>5</sup>

Fig 5: A Simple Simulation Test Using Schematic Capture<sup>6</sup>



## Simple Combinational Design Verilog Code for k-bit 2x1 Mux and k-bit Adder

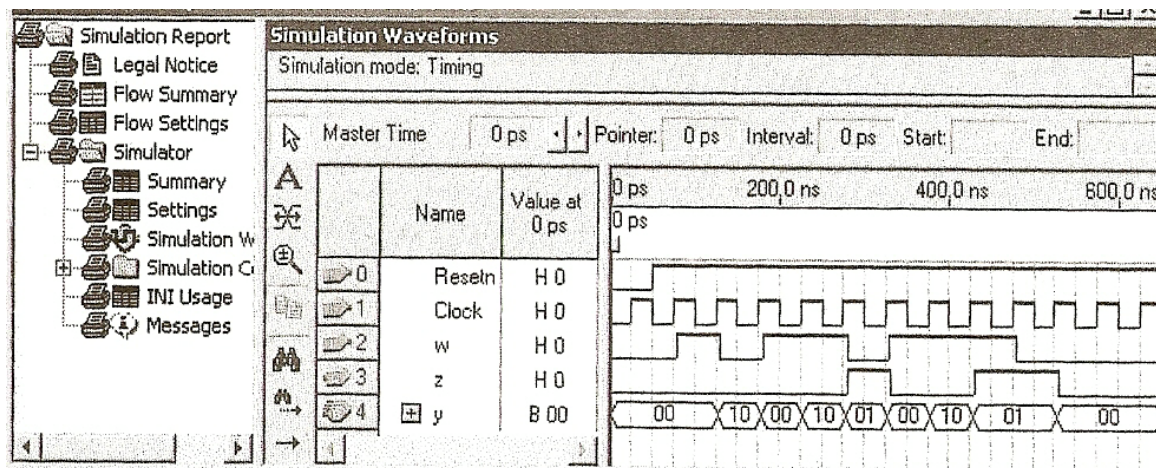
```
// k-bit 2-to-1 multiplexer
module mux2to1 (V, W, Selm, F);
  parameter k = 8;
  input [k-1:0] V, W;
  input Selm;
  output [k-1:0] F;
  reg [k-1:0] F;

  always @(V or W or Selm)
    if (Selm == 0) F = V;
    else F = W;
endmodule

// k-bit adder
module adderk (carryin, X, Y, S, carryout);
  parameter k = 8;
  input [k-1:0] X, Y;
  input carryin;
  output [k-1:0] S;
  output carryout;
  reg [k-1:0] S;
  reg carryout;

  always @(X or Y or carryin)
    {carryout, S} = X + Y + carryin;
endmodule
```

Fig 6: A Typical Simulation Result of Test Run Using Verilog<sup>5</sup>



## Sequential Circuit Code For 2-bit BCD Counter Verilog Code

```

module BCDcount (Clock, Clear, E, BCD1, BCD0);
    input Clock, Clear, E;
    output reg [3:0] BCD1, BCD0;

    always @(posedge Clock)
    begin
        if (Clear)
        begin
            BCD1 <= 0;
            BCD0 <= 0;
        end
        else if (E)
        if (BCD0 == 4'b1001)
        begin
            BCD0 <= 0;
            if (BCD1 == 4'b1001)
                BCD1 <= 0;
            else
                BCD1 <= BCD1 + 1;
        end
        else
            BCD0 <= BCD0 + 1;
    end

endmodule

```

## Laboratory Experiments

1. Introduction to Quartus II<sup>6</sup> software
2. Introduction to combinational logic and Verilog
3. Multiplexes and Decoders
4. Introduction to Flip-Flops
5. Counters
6. State Machine Design<sup>2</sup>
7. Projects

## Conclusions

The FPGA course was successfully taught and provided students with good basic knowledge of Verilog HDL. The Altea DE-2<sup>6</sup> board is user friendly and students had no problems using it. In the future more complex projects will be assigned to students using faster clocks and LCD display, which are on board features. This course will be made a required core course in the future, which will follow combinational logic and sequential logic courses. I had inquires from several companies who are looking for students with FPGA design experience. I think this course fits very well in Electronics and Computer Engineering Technology curriculum.

## References

1. Altera Cooperation, Quartus II Web Edition Software, March, 2007
2. Mano, Morris M., Digital Design, 3<sup>rd</sup> Edition, Prentice-Hall, Inc., 2006
3. McGrath, Dylan, "FPGA Market to Pass \$2.7 Billion by '10", May 24, 2008
4. Chang, K.C., Digital System Design with VHDL and Synthesis, IEEE CS, 2006
5. Sandige, Richard S., Digital Design Essentials, Prentice-Hall Inc., 2002
6. Altera Cooperation, FPGA University Program Tutorial Using Verilog HDL, 2008

## Biography

**Tariq Qayyum** graduated from University of Engineering and Technology Lahore, Pakistan with BSEE degree in 1978 and with MSEE degree from Rochester Institute of Technology, Rochester New York in 1982. He has been teaching at Cal Poly Pomona since 1986. His interest includes digital design, microprocessors, and programming languages.



## **Design, Fabrication, and Analysis of Photodynamic Therapy Oxygen Monitoring System For Use In Esophageal Carcinoma**

**Gemunu Happawana<sup>1</sup>, Amaranath Premasiri<sup>2</sup>, Arye Rosen<sup>3</sup>**

<sup>1</sup>Department of Mechanical Engineering, California State University, Fresno, CA 93740, email: ghappawana@csufresno.edu, 559-278-6832, Fax: 559-278-2368.

<sup>2</sup>Department of Mechanical Engineering, Southern Methodist University, Dallas, TX, 75275, email: apremasi@smu.edu, 214-768-1966, Fax: 214-768-1473.

<sup>3</sup>Electrical and Biomedical Engineering, Bossone 7-504, Drexel University, Philadelphia, PA, 19104, email: ar86@drexel.edu, 215-895-1913, Fax: 215-895-4983

### **Abstract**

Photodynamic therapy (PDT) is an effective and minimally invasive treatment modality with relatively fewer side effects than chemotherapy and radiation, which has been approved by the FDA for treatment of esophageal cancer. Maximum therapeutic outcome of the PDT protocol for each individual patient requires optimization of the components of PDT operating at their highest efficacy. Tumor necrosis, the method of malignant tissue destruction by PDT, is carried out by the toxic singlet oxygen molecules that are being formed from the molecular oxygen in the tumor. The availability of molecular oxygen, being the rate limiting step for PDT, plays a key role in the treatment protocol. Currently, the PDT of esophageal carcinoma is a relatively blind process since there is no method to monitor the tumor oxygen level during the treatment. In this paper, we present an optical technique to monitor molecular oxygen level in the PDT milieu. The method described herein is a reflection oximetry technique designed with small semiconductor lasers and a silicon photodiode. The light used for monitoring system comes from two semiconductor diode lasers of 650 nm and 940 nm wavelengths. The two lasers and the photodiode are integrated into a small package which is then mounted onto a balloon catheter containing the PDT light delivery system. The lasers and photodiode are powered and controlled by a control box that is connected via a cable. The light sources and the photodiode output are controlled by LabVIEW virtual instrumentation. The sequential on and off light sources and the respective reflective signals are processed with MATLAB. The latter code integrates with LabVIEW to make an automatic calculation of the corresponding light absorption by each chromophore to determine the change in oxygen level as well as the amount of blood and oxygen present in the treatment area. The designed system is capable of monitoring the change in oxygen level and the blood flow in any part of the human body where it is possible to place the package.

**Key words:** Photodynamic therapy, esophageal carcinoma, oxygen detection, photonic reflective oximeter

## 1. Introduction

Oxygen is a key element in PDT and would deplete with time<sup>1</sup>. Oxygen and photosensitizer level monitoring during PDT are effective ways of maintaining the optimum concentrations of this rate limiting substance throughout the treatment process. The photo bleaching of photosensitizer is also considerable during PDT. Preferably, such information should be available to clinicians on a continuous basis rather than at the beginning and at the end of the treatment. This requirement can be met non-invasively with the technology of optical detection. The optical techniques are now well established and are in regular clinical use during anesthesia and intensive care when monitoring patient vitals.

An oximeter is a commonly used biomedical instrument to detect the oxygen content in capillaries<sup>2, 3-11</sup>. Pulse oximeters are commonly used instruments for *in-vivo* reading<sup>12, 13-14</sup>. While this is not a perfect method to read the true arterial oxygen saturation of human tissues, its principle can be used to measure the relative oxygen concentration in a tumor during PDT<sup>15</sup>. The physics behind this technique is based on the light absorption of the two different types of hemoglobin, oxyhemoglobin (HbO<sub>2</sub>) and deoxyhemoglobin (Hb), in the blood stream. This work discusses the integration of an optical detection system into the PDT balloon catheter using an integrated system of detector and lasers to monitor the oxygen level and the photosensitizer concentration. Light transmitted through a tissue is detected and the portion of absorbed energy is calculated to analyze the oxygen content. Light transmitted through a chromophore is given by the Beer-Lambert equation<sup>13</sup>.

The change in blood chromophores in the tissue can be modeled with the modified Beer-Lambert law. When the light source and the detector are located on a tissue the detector receives backscattered light. The amplitude of the light that the detector receives can be very much less, compared to the light emitted by the source, due to scattering and absorption by the tissue. Therefore, usage of high power light sources and efficient detectors to measure the backscattered light are very important in a detection system.

## 2. Theory of reflectance optical detection system

The physical requirement necessary for an optical system in order to detect multiple numbers of chromophores is to have light sources of specific wavelength with different absorptivity pattern. The light attenuation between the source and the detector can be written as follows:

$$-\log_{10}\left(\frac{I_{out}}{I_{in}}\right) = OD_{\lambda} \quad (1)$$

where  $I_{in}$  is the incident light,  $I_{out}$  is the detected light, and  $OD_{\lambda}$  is the optical density for wavelength  $\lambda$ . Optical density is a function of absorption ( $A_{\lambda}$ ) and scattering ( $S_{\lambda}$ ) of wavelength  $\lambda$ . Therefore, Eq.(2) can be rewritten as follows:

$$-\log_{10}\left(\frac{I_{out}}{I_{in}}\right) = OD_{\lambda} = attenuation = A_{\lambda} + S_{\lambda} \quad (2)$$

$HbO_2$ ,  $Hb$ , and the photosensitizer (PS) are the main absorber chromophores in the PDT environment. Therefore, the light absorption can be written as follows:

$$A_{\lambda} = \epsilon_{HbO_2, \lambda} C_{HbO_2} L_{\lambda} + \epsilon_{Hb, \lambda} C_{Hb} L_{\lambda} + \epsilon_{PS, \lambda} C_{PS} L_{\lambda} \quad (3)$$

where  $\varepsilon_{HbO_2,\lambda}$ ,  $\varepsilon_{Hb,\lambda}$ , and  $\varepsilon_{PS,\lambda}$  are the specific extinction coefficient of oxyhemoglobin, deoxyhemoglobin and photosensitizing agent for wavelength  $\lambda$ .  $C_{HbO_2}$ ,  $C_{Hb}$ , and  $C_{PS}$  are the concentrations of the oxyhemoglobin (HbO<sub>2</sub>), deoxyhemoglobin (Hb) and photosensitizing agent respectively, and  $L_\lambda$  is the optical path length. This optical path length can be expressed as source detector separation,

$$L_\lambda = d.DPF_\lambda \quad (4)$$

where  $d$  is the separation between the light source and the detector and  $DPF_\lambda$  is the differential path length factor. The correction for the mean photon path length for scattering, is termed the differential pathlength factor, and expressed as follows<sup>16</sup>:

$$DPF_\lambda = \frac{1}{2} \left( \frac{3\mu'_{s,\lambda}}{\mu_{a,\lambda}} \right)^{1/2} \left[ 1 - \frac{1}{1 + d.(3\mu'_{s,\lambda}\mu_{a,\lambda})^{1/2}} \right] \quad (5)$$

where  $\mu_{a,\lambda}$  is the absorption coefficient and  $\mu'_{s,\lambda}$  is the reduced scattering coefficient at wavelength  $\lambda$ . Consumption of oxygen in blood, during the PDT reaction, leads to reduction in oxyhemoglobin concentration. Therefore the optical density  $OD_\lambda$ , varies with time. This differential  $OD_\lambda$  value can be written as follows:

$$\Delta OD_\lambda = OD_{\lambda,final} - OD_{\lambda,initial} = d.DPF_\lambda (\varepsilon_{HbO_2,\lambda} \Delta C_{HbO_2} + \varepsilon_{Hb,\lambda} \Delta C_{Hb} + \varepsilon_{PS,\lambda} \Delta C_{PS}) \quad (6)$$

Thereafter the effect of scattering is not influential to the model. Each chromophore has a specific extinction coefficient and a differential pathlength factor. Therefore, measurements with the three wavelengths give

$$\Delta OD_{\lambda_1} = d.DPF_{\lambda_1} (\varepsilon_{HbO_2,\lambda_1} \Delta C_{HbO_2} + \varepsilon_{Hb,\lambda_1} \Delta C_{Hb} + \varepsilon_{PS,\lambda_1} \Delta C_{PS}) \quad (7)$$

$$\Delta OD_{\lambda_2} = d.DPF_{\lambda_2} (\varepsilon_{HbO_2,\lambda_2} \Delta C_{HbO_2} + \varepsilon_{Hb,\lambda_2} \Delta C_{Hb} + \varepsilon_{PS,\lambda_2} \Delta C_{PS}) \quad (8)$$

$$\Delta OD_{\lambda_3} = d.DPF_{\lambda_3} (\varepsilon_{HbO_2,\lambda_3} \Delta C_{HbO_2} + \varepsilon_{Hb,\lambda_3} \Delta C_{Hb} + \varepsilon_{PS,\lambda_3} \Delta C_{PS})$$

Solving Eq.(7), Eq.(8) and Eq.(9) we obtain the general equations for three different

chromophores in blood,  $\Delta C_{HbO_2}$ ,  $\Delta C_{Hb}$ , and  $\Delta C_{PS}$ :

$$\begin{aligned} \Delta C_{HbO_2} = & \frac{\Delta OD_{\lambda_3} .DPF_{\lambda_1} .DPF_{\lambda_2} .(\varepsilon_{PS,\lambda_1} .\varepsilon_{Hb,\lambda_2} - \varepsilon_{Hb,\lambda_1} .\varepsilon_{PS,\lambda_2})}{a_1} + \\ & \frac{\Delta OD_{\lambda_2} .DPF_{\lambda_1} .DPF_{\lambda_3} .(\varepsilon_{Hb,\lambda_1} .\varepsilon_{PS,\lambda_3} - \varepsilon_{PS,\lambda_3} .\varepsilon_{Hb,\lambda_2})}{a_1} + \\ & \frac{\Delta OD_{\lambda_1} .DPF_{\lambda_2} .DPF_{\lambda_3} .(\varepsilon_{PS,\lambda_2} .\varepsilon_{Hb,\lambda_3} - \varepsilon_{Hb,\lambda_2} .\varepsilon_{PS,\lambda_3})}{a_1} \end{aligned} \quad (10)$$

$$\Delta C_{Hb} = \frac{\Delta OD_{\lambda_3} \cdot DPF_{\lambda_1} \cdot DPF_{\lambda_2} \cdot (\epsilon_{HbO_2, \lambda_1} \cdot \epsilon_{PS, \lambda_2} - \epsilon_{PS, \lambda_1} \cdot \epsilon_{HbO_2, \lambda_2})}{a_1} + \frac{\Delta OD_{\lambda_2} \cdot DPF_{\lambda_1} \cdot DPF_{\lambda_3} \cdot (\epsilon_{PS, \lambda_1} \cdot \epsilon_{HbO_2, \lambda_3} - \epsilon_{HbO_2, \lambda_1} \cdot \epsilon_{PS, \lambda_3})}{a_1} + \frac{\Delta OD_{\lambda_1} \cdot DPF_{\lambda_2} \cdot DPF_{\lambda_3} \cdot (\epsilon_{Hb, \lambda_2} \cdot \epsilon_{PS, \lambda_3} - \epsilon_{PS, \lambda_2} \cdot \epsilon_{HbO_2, \lambda_3})}{a_1} \quad (11)$$

$$\Delta C_{PS} = \frac{\Delta OD_{\lambda_3} \cdot DPF_{\lambda_1} \cdot DPF_{\lambda_2} \cdot (\epsilon_{HbO_2, \lambda_1} \cdot \epsilon_{Hb, \lambda_2} - \epsilon_{Hb, \lambda_1} \cdot \epsilon_{HbO_2, \lambda_2})}{a_1} + \frac{\Delta OD_{\lambda_2} \cdot DPF_{\lambda_1} \cdot DPF_{\lambda_3} \cdot (\epsilon_{Hb, \lambda_1} \cdot \epsilon_{HbO_2, \lambda_3} - \epsilon_{HbO_2, \lambda_1} \cdot \epsilon_{Hb, \lambda_3})}{a_1} + \frac{\Delta OD_{\lambda_1} \cdot DPF_{\lambda_2} \cdot DPF_{\lambda_3} \cdot (\epsilon_{HbO_2, \lambda_2} \cdot \epsilon_{PS, \lambda_3} - \epsilon_{Hb, \lambda_2} \cdot \epsilon_{HbO_2, \lambda_3})}{a_1} \quad (12)$$

where

$$a_1 = DPF_{\lambda_1} DPF_{\lambda_2} DPF_{\lambda_3} \cdot d(\epsilon_{PS, \lambda_1} \epsilon_{Hb, \lambda_2} \epsilon_{HbO_2, \lambda_3} + \epsilon_{HbO_2, \lambda_1} \epsilon_{PS, \lambda_2} \epsilon_{Hb, \lambda_3} + \epsilon_{Hb, \lambda_1} \epsilon_{Hb, \lambda_2} \epsilon_{PS, \lambda_3} - \epsilon_{Hb, \lambda_1} \epsilon_{PS, \lambda_2} \epsilon_{HbO_2, \lambda_3} - \epsilon_{PS, \lambda_1} \epsilon_{HbO_2, \lambda_2} \epsilon_{Hb, \lambda_3} - \epsilon_{HbO_2, \lambda_1} \epsilon_{Hb, \lambda_2} \epsilon_{PS, \lambda_3})$$

The change in oxygen level and photosensitizer level is given as follows:

$$\Delta OXY = OXY_{t_1} - OXY_{t_2} \quad (13)$$

$$\Delta PS = PS_{t_1} - PS_{t_2} \quad (14)$$

where  $OXY$  and  $BV$  are oxyhemoglobin and blood volume changes:

$$OXY = \Delta C_{HbO_2} - \Delta C_{Hb} \quad (15)$$

and

$$BV = \Delta C_{HbO_2} + \Delta C_{Hb} \quad (16)$$

Therefore, a system with two different light sources and a light detector can evaluate the intensity of the incident light and the detected reflected light and thereby calculate the concentration of hemoglobin and oxyhemoglobin.

### 3. The system design

As explained previously there should be at least three different wavelengths to monitor the blood chromophore level and the photosensitizing agents. Many number of light sources from each wavelength, and many number of detectors can be used for this purpose. However increasing the number of devices complicates the probe geometry. The proposed detection system design consists of three semiconductor lasers for the excitation of the chromospheres and a detector. In

the device fabrication we include two light sources and a photodetector packaged together as shown in Fig.1.

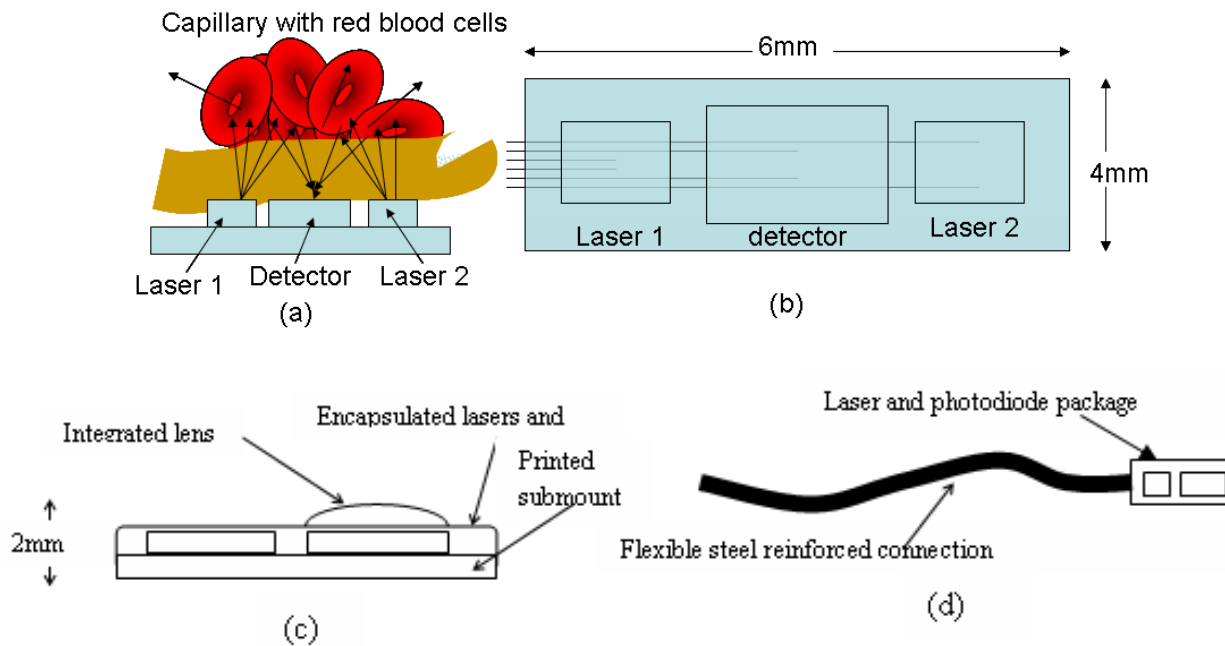


Fig.1: (a) Oxygen detection system in the presence of blood chromophore; (b) circuit for lasers and the detector; (c) encapsulated cross section with lens; and (d) system design to insert into the balloon catheter.

The prototype development and the testing could be performed with any type of photosensitizing agent. The locations of the light sources are determined by the light scattering distance of living tissue. In this work, a center-to-center distance of a light source and the detector is kept at 1cm. This distance provides sufficient spacing for the prototype fabrication and also for the detector to receive enough photons to give an appropriate signal output. The power supply, control system, and data acquisition system are connected to the insertable package. Figure 1 shows a diagram of the insertable part of the detection system.

The ideal probe to be used for PDT of esophageal carcinoma will have the following special features. The lasers and the photodetector are packaged onto a printed circuit sub-mount for miniaturization. The package is then encapsulated in a perfectly amorphous polymer to prevent the circuitry from damage during operation (Fig.1(c)). A concave lens is integrated onto the photodiode to collect maximum reflected light, as shown in Fig.1(c). The packaged lasers and the photodetector are connected to a flexible steel cable (Fig.1(d)), so that the entire detection unit can be moved inside the balloon catheter to the precise location of the tumor. Figure 2 gives a block diagram of the oxygen detection system. The oxygen detection system would be calibrated and validated using a commercially available oxygen detection system. This system is designed without an advanced laser driver; it uses a less expensive DC power supply or a 12V battery. The selection of the power supply is based on the power requirement of the semiconductor lasers and the detector bias voltage.

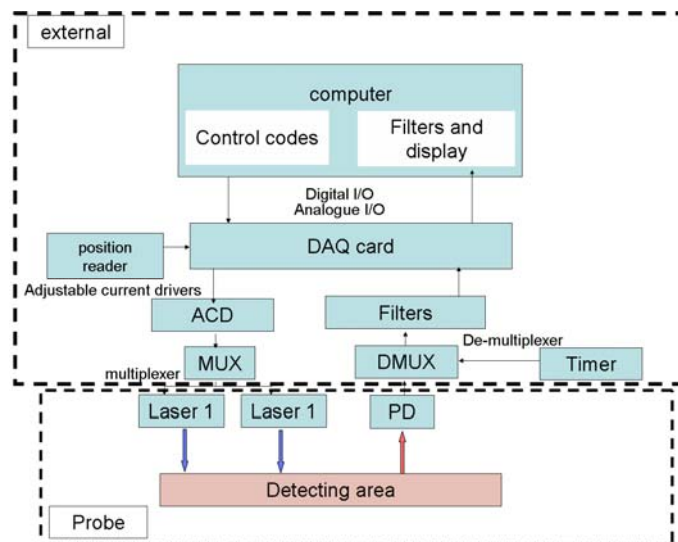


Fig.2: Schematic of the oxygen detection system.

### 3.1 Selection of the exciting light wavelength

Certain wavelengths transmitted, through a photosensitizing agent accumulated tissue, is absorbed by the photosensitizing agent and the agent will fluoresce upon onset of a light. The fluorescence intensity is dependent on the amount of oxygen in a tumor. A normal tissue has more oxy-hemoglobin and hence more oxygen. Fluorescence spectrum of the photosensitizing agent (Photofrin) accumulated tumor and normal tissue is shown in Fig.3. The fluorescence spectrum clearly shows the fluorescence intensity difference in the tumor and the normal tissue at a range of wavelengths. Also, as seen in Fig.3, at certain wavelengths, higher than 750 nm wavelengths, there is no difference in fluorescence spectrum by the photosensitizing agent of the tumor and the normal tissue.

The largest difference between the tumor and the normal tissue fluorescence for the Photofrin photosensitizer lies between 650nm to 675nm (Region1 in Fig. 3). The wavelengths on or above 750 nm, infrared (IR) Region 2 in Fig. 3, shows no difference in the fluorescence spectrum of the tumor and the normal tissue. Therefore, in the selection of the wavelengths the first laser is selected with 650nm and the other with 904 nm. These two selections provide a better spectral heterogeneity for the oxygen detection. Semiconductor lasers of these wavelengths are commercially available at reasonable prices.

The typical operating voltage of the 650nm semiconductor laser selected for the application is 2.3V and the maximum voltage is 2.6V. The recommended operating voltage for 904nm laser is 1.8V to 2.5V, and the suggested typical voltage is 2.0V. The operating temperature range of the 650nm laser is -10 to 70°C and for the 904nm laser is -10 to +50°C. These operating temperatures are adequate to drive the lasers in a low duty cycle without degrading the lasers.

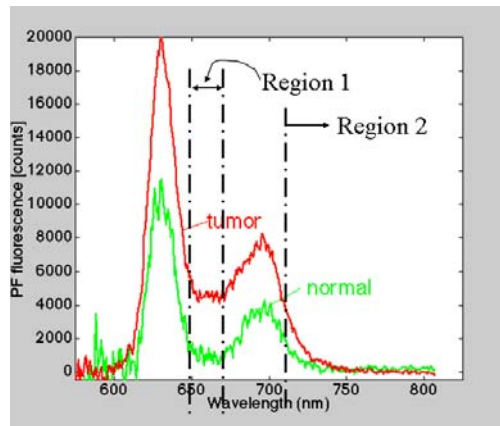


Fig. 3: Sum of the auto fluorescence and fluorescence of Photofrin in an epithelial cell<sup>12</sup>.

### 3.2 Detector selection

The light detector is selected to sense the backscattered light of 650nm and 940nm. A commercially available silicon photodiode with a spectral response of 350-1100 nm is used for the package to detect the range of light (including detection of the fluorescence of a photosensitizer). The rise and fall times of the photodiode are both 10ns at 20V bias voltage with a 50 $\Omega$  load. This is, therefore, well suited for this application since the current saturation does not interfere with the light emitting sequence. The active area of this detector is 13mm<sup>2</sup> and the detector is packaged in a standard T05 (0.36") submount. This packaged detector is used only for the prototype design. In an actual device fabrication, the detector and the lasers could be imprinted onto a balloon catheter for smaller size devices.

### 4. Control system layout and oxygen monitoring technique

The two lasers in the probe are driven by a simple DC power supply. Duty cycles of the lasers are determined by the detector rise time, fall time and also the operating temperatures of the lasers. Both selected lasers show high operating temperatures, although it is preferable to keep the laser operating temperature at a stable point to avoid wavelength shift. Therefore the laser controlling circuit is designed with a timing component that makes the laser drive in for a very short time period, which is necessary to excite the monitoring area. A National semiconductor TLC555 timer is used as the center component of the timing circuit. The timer capacitance and the resistors are used in such a way that the current is driven in the circuit within one tenth of a second.

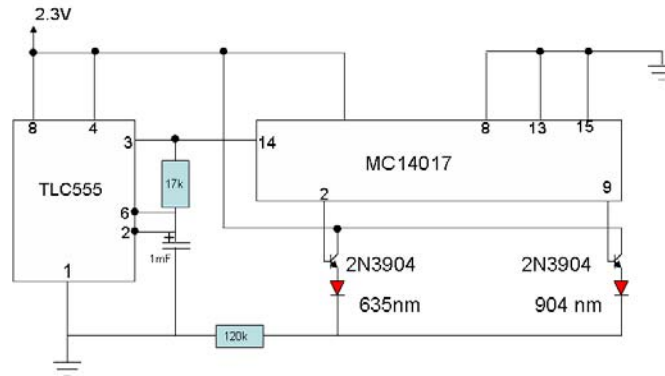


Fig.4: Laser controlling circuit with 2.3V power input

The timer output current is divided into separate two channels, using a decade counter as shown in the Fig.4. MC14017B five-stage Johnson decade counter is used in the circuit. This consumes very little power and gives a spike-free output. The decade counter can supply ten separate leads. In this application, only two leads are used while the rest are kept grounded. The circuit is set up to operate on each laser in a pulsed mode with every 0.9 second pulsed width and 0.05 second dwell to avoid thermal buildup inside the lasers. The lasers are connected to the emitter of an NPN transistor, whose base is connected to the main power supply, and the collector to the decade counter output. In this way, the laser power input is kept constant and at an expected value. The lasers are connected to the decade counter through transistors, where the main power source to lasers is connected. The silicon detector is connected to a 12V bias voltage supply. This is the supply voltage to the controlling circuit. The laser driving voltage of 2.3V is supplied from this source, through a voltage divider.

## 5. Fabrication of blood oxygen monitoring system

### 5.1 Probe design

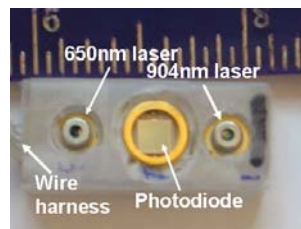


Fig. 5: Prototype of the probe design

For the prototype fabrication we have used packaged lasers and a germanium photodiode due to commercial availability and cost effectiveness. Un-packaged devices can be easily incorporated into the probe when the prototype design is verified with the experimental data. In the final design, the probe was encapsulated with a transparent polymer material to protect the complete circuitry from shear forces generated during insertion of the balloon catheter system into the esophagus. As shown in Fig. 5, the photodiode and lasers are packaged in a Teflon block. The wire connections for the detector and the lasers are at the bottom of the package, firmly connected to the block, where possible mishandling would not damage the wire connections.



## 5.2 Data acquisition and data acquisition system

LabVIEW (National Instruments) is used for data acquisition and the desired output. NI-DAQmx a subprogram in the LabVIEW is used in developing the virtual instrumentation for the oxygen detection system, which is now used in most of the industrial setting for data acquisition and instrument control.

The front panel of the LabVIEW consists of three different waveform charts that provide the raw detector signal without digital filtering, the digitally filtered input signal, and the variation of hemoglobin and oxyhemoglobin. NI 6221 DAQ card was used with SCB-68 shielded I/O connector block. The SCB-68 opens the connection to the controller circuit with virtual instrumentation. The detector voltage outputs that belong to the respective lasers are fed to the connector block. LabVIEW DAQ, signal conditioning hardware and software, provides graphical development of the control. DAQmx detector output signal is split into two signals as the initial step in the process. These signals are acquired with a certain time difference, which is removed by modifying the signal at second stage by adding the time difference to the trailing signal. Optical input to output ratio is calculated thereafter. The signal is then sent through a band pass filter before it is input to the mathscript node.

## 6. The experimental setup

The experimental setup consists of the proto board where the controlling circuit was built, two power supplies, two multimeters and a personal computer in which NI LabVIEW was installed. The detector reading acquired by the LabVIEW program is validated with the multimeters connected to the physical channel of the detector output. The circuit design is assumed to have zero generation of crosstalk, since the current and signals always travel in one path at any given time. Following this, the interference of signals in different paths is minimal and the noise generated is negligible.

The actual system does not consist of these additional equipments. Final instrumentation consists only of the DC power supply, in addition to the controlling circuit and the probe. The DC power supply is set for the 12V output, which is necessary for the detector reverse voltage. This system can be easily powered by a 12V battery pack, when there is no main power supply available. The preliminary testing with the probe and the detection system was done with the upper limb of the author. Even though the system is designed for the use in esophagus, it is not possible to conduct an in-vivo testing with the esophageal tissue under currently available laboratory conditions. The probe was moved to several places to observe uninterrupted reading, yet it was noted that the pulsative blood flow adds a degree of noise to the reading. This noise however, does not to the general reading required to monitor the oxygen level.

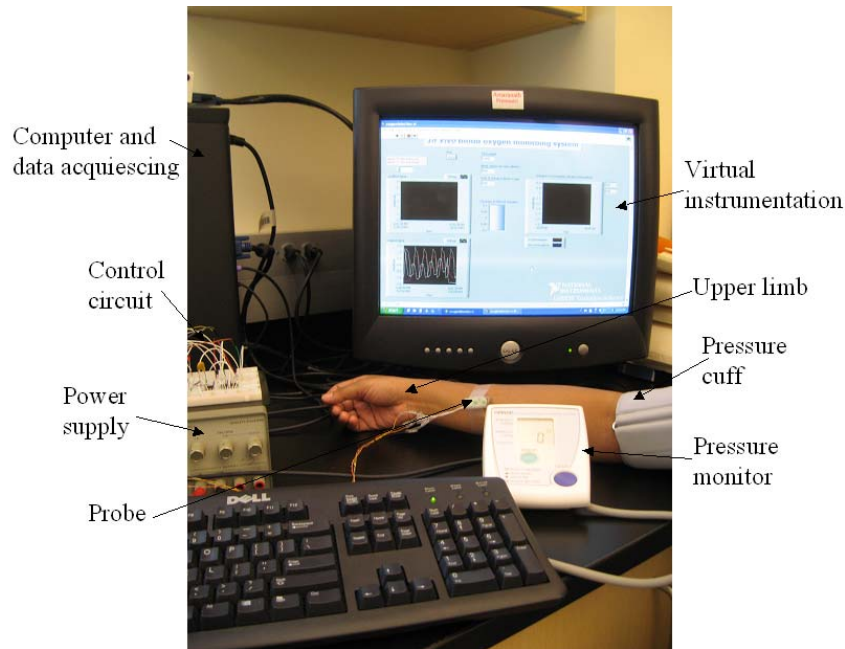


Fig.6: Testing of the oxygen detection system on human upper limb to evaluate the detector capability. The experiment is conducted to see the signal capturing of the diode detector.

## 6. Preliminary results

A set of experimental results was obtained to validate the probe design and the data acquisition system, using the author's upper arm. The probe was firmly held against the skin by a tape, as shown in Fig.6. The absorption and scattering of 904 nm light is comparatively less than that of 650nm light. Therefore the ratio of the light signal emitted by the laser to the light signal received by the detector is higher in the higher wavelengths. The detector signal was slightly different when the probe was placed on the limb since the blood flow, in pulsatile manner, adds noise to the detector signal. This noise does not deteriorate the monitoring process since it was present throughout. Attenuation is possible by selecting a monitoring location such as the ear lobe, with minimal interruption by other blood vessels. However, the selection of such a placement is only necessary for calibration purpose, since the final probe design should be able to monitor the esophageal environment, which is closer to the heart.

The final set of reading was obtained to verify the system capability to capture a change in blood oxygen level. Application of a 140 mmHg pressure to upper limb, which is above the systolic blood pressure for a particular subject, will cut off the blood supply completely for the period of pressure application. As a consequence, the fraction of deoxyhemoglobin in the distal part of the upper limb is increased. The difference of oxyhemoglobin and deoxyhemoglobin is detected by the monitoring system, as shown by the separation of the two data lines (Fig.7). Figure 7 illustrate the oxyhemoglobin (—◆—) reading and deoxyhemoglobin (—■—) reading for 120 second where application of pressure is initiated in 20 second after the beginning of the reading. Further verification of the system with Photofrin® contacting environment is required to test how far the system fulfills the design objective

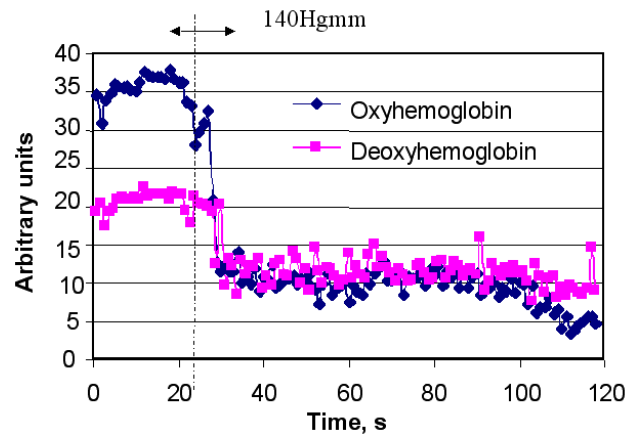


Fig.7: oxyhemoglobin and deoxyhemoglobin readings when 140Hgmm pressure is applied.

## 7. Discussion

A photonic reflectance oximeter is designed, analyzed, and fabricated. The specific device selection, to be used alone with PDT, is discussed. The application of the designed system is not specific to esophagus. The system is designed either to be used inside an internal organ or on the skin, where melanin plays a major role in light scattering and absorption. The virtual instrumentation is developed to change its formulation in accordance with the location of the monitoring. The virtual instrumentation instantly gives the change in blood oxygen content and the blood volume. The absolute change in oxygen level can be derived by calibrating the system, using existing oxygen monitoring systems. The change of oxyhemoglobin and deoxyhemoglobin is given relative to the initial level of each component. This is an important advancement in the case of PDT.

The prototype used commercially available lasers and detectors so that the current probe is relatively large in size to be compared to the light delivery system to be designed for the esophagus. However, it is not a complicated task to fabricate a probe that can be imprinted onto a balloon catheter. The oxygen detection system can be further modified and incorporated into the light detection system, added to the rear side of the detector probe, for monitoring of the photosensitizer fluorescence signal. All commercially available photosensitizers give a significant fluorescence signal that can be easily filtered and used for monitoring purposes.

## References

1. J. D. Chapman, C.C. Stobbe, M.R. Arnfield, R. Santus, J.lee, and M.S. McPhee, "Oxygen dependency of tumor cell killing in vitro by light-activated Photofrin II", *Radiat. Res*, Vol.126, no.1, pp.73-79, 2005.
2. D. J. Robinson, H. S. de Bruijn, d. van, V, M. R. Stringer, S. B. Brown, and W. M. Star, "Fluorescence photobleaching of ALA-induced protoporphyrin IX during photodynamic therapy of normal hairless mouse skin: the effect of light dose and irradiance and the resulting biological effect," *Photochem. Photobiol.*, vol. 67, no.1, pp. 140-149, 1998.
3. A. Curnow, J. C. Haller, and S. G. Brown, "oxygen monitoring during 5-amonolaevulinic acid induced photodynamic therapy in normal rat colon. Comparison of continuous and fractionated light regime", *J.Photochem.Photobiol.B*, Vol.58, no.2-3,pp.149-155, 2000.

4. Jr. Edgar, W. Reuben, Gilstad, W. Dennis, Branstetter., and L. Ronald, "Method and apparatus for noninvasive monitoring of arterial blood oxygen saturation,"4714080, 1987.
5. R. L. Sheridan, K. M. Prelack, L. M. Petras, S. K. Szyfelbein, and R. G. Tompkins, Intraoperative reflectance oximetry in burn patients," J. Clin. Monit., vol. 11, no. 1, pp. 32-34, 1995.
6. S. Nioka, M. Izzetoglu, T. Mawn, M. J. Nijland, D. Boas, and B. Chance, "Fetal transabdominal pulse oximeter studies using a hypoxic sheep model," J. Matern. Fetal Neonatal Med., vol. 17, no. 6, pp. 393-399, 2005.
7. M. J. Decker, D. Dickensheets, J. L. Arnold, P. W. Cheung, and K. P. Strohl, "A comparison of a new reflectance oximeter with the Hewlett-Packard ear oximeter," Biomed. Instrum. Technol, vol. 24, no. 2, pp. 122-126, 1990.
8. T. Durduran, G. Yu, M. G. Burnett, J. A. Detre, J. H. Greenberg, J. Wang, C. Zhou, and A. G. Yodh, "Diffuse optical measurement of blood flow, blood oxygenation, and metabolism in a human brain during sensorimotor cortex activation," Opt. Lett., vol. 29, no. 15, pp. 1766-1768, 2004.
9. J. Ling, S. Takatani, G. P. Noon, and Y. Nose, "In-vivo studies of reflectance pulse oximeter sensor," in Physiological Imaging, Spectroscopy, and Early Detection Diagnostic Methods, SPIE, 1887, pp. 256-262, 1993.
10. I. Charamisinau, K. Keymel, W. Potter, and A. R. Oseroff, "Handheld dual fluorescence and reflection spectroscopy system for monitoring topical low dose ALA-PDT of actinic keratoses (AK)," Optical methods for tumor treatments and detection: mechanisms and techniques in photodynamic therapy XV, SPIE, 6139, 2006, pp. 318-327.
11. A. E. El-Desoky, A. Seifalian, M. Cope, D. Delpy, and B. Davidson, "Changes in tissue oxygenation of the porcine liver measured by near-infrared spectroscopy," Liver Transpl. Surg., vol. 5, no. 3, pp. 219-226, 1999.
12. S. Mitra and T. H. Foster, "Photochemical oxygen consumption sensitized by a Porphyrin phosphorescent probe in two systems," Biophysical Journal, vol. 78, pp. 2597-2605, 2000.
13. J. G. Webster, Design of pulse oximeters, 1 ed J. W. Arrowsmith Ltd, Bristol, UK, 1997.
14. M. Fernandez, K. Burns, B. Calhoun, S. George, B. Martin, and C. Weaver, "Evaluation of a new pulse oximeter sensor," Am. J. Crit Care, vol. 16, no. 2, pp. 146-152, 2007.
15. A. Cohen and N. Wadsworth, "A light emitting diode skin reflectance oximeter," Med. Biol. Eng. vol. 10, no. 3, pp. 385-391, 1972.
16. A. Bozkurt, A. Rosen, H. Rosen, and B. Onaral, "A portable near infrared spectroscopy system for bedside monitoring of newborn brain", Biomed Eng Online, vol.4, no.29, 2005.

## BIOGRAPHIES

**Dr. Gemunu S. Happawana** is an associate professor in the department of mechanical engineering at California State University, Fresno. Dr. Happawana holds a Ph.D. (1994) in mechanical engineering and Master of Science degree (1988) in mathematics from Purdue University, and Bachelor of Science degree (1984) with honors in mathematics from University of Colombo, Sri-Lanka. His work lies in the fields of mechanical vibration, applied mechanics and photonics, and it combines physical modeling, analytical techniques, and measurement. Dr. Happawana serves as advisor to Mini-Baja and Formula SAE student competitions. Dr. Happawana is a consultant to the high tech photonics company, Photodigm, Inc., Dallas, Texas, since 2000. He is named as Patton Industry Faculty Fellow. He has worked on converting gasoline engines to run on ethanol, natural gas or kerosene. He has more than fifty journal and conference papers, one book and two patents pending. He has graduated four Ph.D. students and served on over twenty Ph.D. and MS committees. Affiliations: SAE (member), ASME (member), OSA (member).

**Dr. Amaranath Premasiri** received a BSc. degree in Materials Engineering (1999) and MEng degree in Mechanical Engineering (2003) from University of Moratuwa, Sri Lanka. He served on the faculty of Mechanical and Manufacturing Engineering of the University of Ruhuna, Sri Lanka between 2000 and 2003. He earned his Ph.D. in mechanical engineering (2008) from Southern Methodist University, Dallas, Texas. He is currently serving as a senior member of the technical staff at Akon, Inc, San Jose, CA. His research area is focused on opto-electronic packaging. He has authored more than 15 peer-reviewed publications on this subject.

**Dr. Arye Rosen** (M'77–SM'80–F'92) received the Masters degree in engineering from Johns Hopkins University, Baltimore, MD, the M.Sc. degree in physiology from Jefferson Medical College, Philadelphia, PA, and the Ph.D. degree in electrical engineering from Drexel University, Philadelphia, PA. Dr. Rosen, has been involved in research and development of microwave/millimeter-wave devices and circuits, microwave optical interaction,

high-power semiconductor lasers and the utilization of energies for application in therapeutic medicine for the past 40 years. He also holds the title of Associate in Medicine at Jefferson Medical College, where he has been engaged in research in the Division of Cardiology since 1970. He has authored more than 200 technical papers, co-edited two books and authored six book-chapters in the field of engineering and medicine. He holds over 60 U.S. patents in the fields of engineering and medicine. Dr. Rosen is an elected Member of the National Academy of Engineering, "For contributions to microwave and laser technologies and the medical applications of these technologies." (2002). He is an Elected Member of The Franklin Institute's Committee on Science and the Arts (2003), and a Member of the John Scott Award Advisory Committee, City of Philadelphia Board of Directors of City Trusts (2004). He is a Life Fellow of IEEE, elected in 1992 "For innovation in semiconductor devices and circuits for use in microwave systems and for microwave applications to medicine." He was IEEE Distinguished Microwave Lecturer from 1997 to 2000, during which time he has presented his and the work of others in the U.S., Japan, Europe and the Middle East. He is the recipient of numerous awards, including the IEEE Third Millennium Medal (January 2000) and an IEEE Microwave Application Award (June 2000). He was also the recipient of a 1989 IEEE Region One Award and a 1997 Drexel University College of Engineering, Electrical and Computer Engineering Department, Distinguished Alumni Award.

## **SimzLab - Interactive simulations of physical systems for active individual and team learning**

by

Richard K. Herz

Chemical Engineering Program and Nanoengineering Department,  
University of California, San Diego <herz@ucsd.edu>

and

Gregory E. Ogden

Chemical and Environmental Engineering Department,  
University of Arizona, Tucson <gogden@email.arizona.edu>

Teaching by lecture and textbook alone does not satisfy students' needs. Many physical systems are too complex to be conveyed fully by the static plots and drawings in books. Essential to learning is active practice and application of new knowledge. Real experiments are wonderful - but cost and space constraints limit the number which can be implemented - usually from zero to a few in most courses. Interactive software simulations can engage students actively in the learning process and help them to understand and work with complex systems. Interactive simulations engage the student<sup>2,3</sup>. They are interesting and fun to use<sup>4-6</sup>, and help students take responsibility for their education<sup>7</sup>.

This paper describes a software application – SimzLab<sup>8</sup> - and what we have learned from developing and using it. Our main objective has been to provide students with virtual lab modules to supplement lecture courses on chemical processes.

SimzLab can distribute multiple sets of modules or "Labs" over the Internet, with each Lab hosted on its own server. The current Labs are Reactor Lab (simulations of chemical reactors) and PureWaterLab (modules on water purification and use). Programming has been done at UCSD and the explanatory text in PureWaterLab has been written at the University of Arizona.

SimzLab is a desktop application which communicates over the Internet with servers. Since it is a desktop application rather than a web browser, it has the full capability of an application such as running compiled C executables for compute-intensive simulations. Since it can connect to the Internet, it has access to protocols such as HTTP, FTP, and TCP/IP sockets.

The software has been developed using a tool with a graphical layout editor and a high-level scripting language<sup>1</sup>. On each client, there is one executable file which has been compiled for that platform (hardware and operating system) and which contains minimal bootstrap code or "script." All other scripts are contained in files which are cross-platform. Whenever a student goes on-line, SimzLab updates any file - both script and content - on the client for which there is a newer version on the server. Currently we only provide Mac and Windows versions of SimzLab, although Linux versions are possible.

Students download the SimzLab application from the web site at [www.SimzLab.com](http://www.SimzLab.com) at no cost. A few modules are provided in the initial distribution. When a student connects SimzLab to the Internet, the student can download additional modules. Once downloaded, a module can be used off-line.

Fig. 1 shows the opening window and the two courses available.



Fig. 1. Opening window showing the sets of course modules currently available.

In the Reactor Lab, many of the modules have two sections: the main entry point in which all inputs and outputs are known to the student, and a quiz section. In the quiz section, students must run experiments, analyze their data, and then check to see if they have an answer within an acceptable range. The Lab charges virtual \$ for each experiment to teach students that they should not run experiments indiscriminately, and then awards them virtual \$ for correct answers. The Budget Report records the history of each quiz. Students must turn in their data, analysis work, and a copy of the Budget Report which contains an authentication code. These quizzes incorporate the features Pavia<sup>9</sup> lists that should be exhibited by a laboratory simulation.

It is interesting to observe a new group of students start to use the software in a computer lab. Doing homework in the Lab is much different than working the usual end-of-chapter homework problems, where usually the necessary and sufficient set of data are given such that a unique answer can be obtained. Some students get the idea and use the Lab enthusiastically. Some students stare at the computer with a concerned look, unsure where to begin. They aren't given data; they have to perform experiments and take their own data and their first experiments may be under conditions which do not provide useful data.

One student was angry, protesting "We are only undergrads! We only know how to work textbook problems!" To which we thought, "Yes, that's exactly the problem!"

As far as functionality, we observed that students highly value software responsiveness (speed) and the ability to use software without having to read instructions.

The Reactor Lab has been used by students all over the world and has been translated by volunteer students and professors into Spanish and Portuguese. Although gratifying, we felt that greater use of the Lab could be obtained if more complete modules with explanatory text were provided in addition to lab simulations. And so, in PureWaterLab, we are developing both explanatory text with graphics and interactive simulations.

The current PureWaterLab course includes an overview on how ultrapure water (UPW) is produced, and detailed modules on specific process components including reverse osmosis, UV photo oxidation, and ion exchange. Fig. 2 shows the Directory window of PureWaterLab.

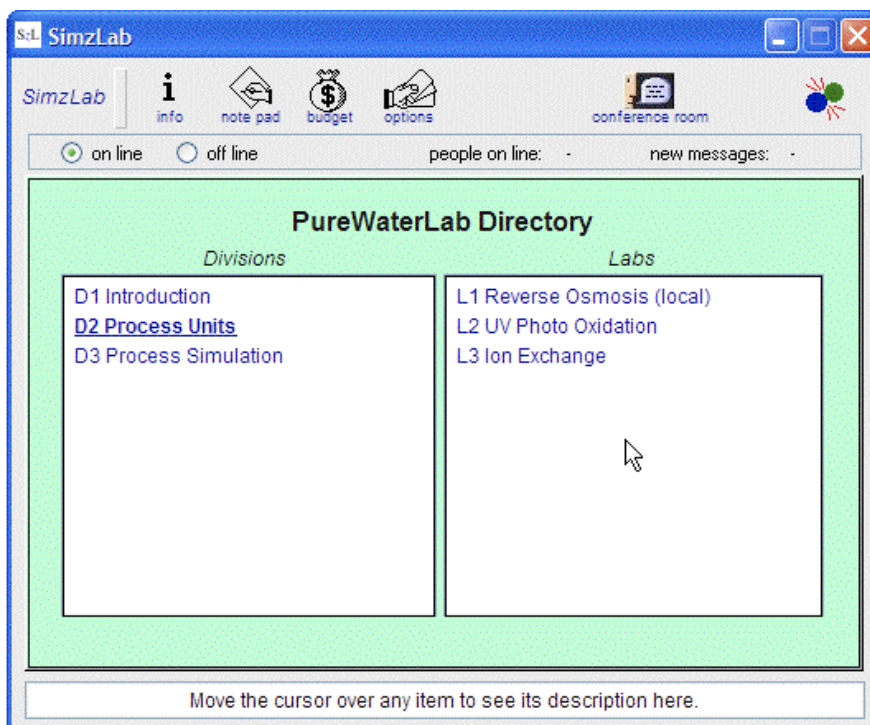


Fig. 2. Directory showing divisions and lab modules in PureWaterLab.

A fourth module in the Process Units division, activated carbon treatment, is under development. The modules include background information, design parameters, treatment capabilities and uses as well as interactive quizzes and homework problems. The simulations are designed to maximize flexibility from "black box" canned response with little user input except for inlet conditions to detailed inputs and operating conditions for more advanced users. Fig. 3 shows a typical the text explanation window and the basic level simulation window open. The module presented in Fig. 3 describes reverse osmosis.



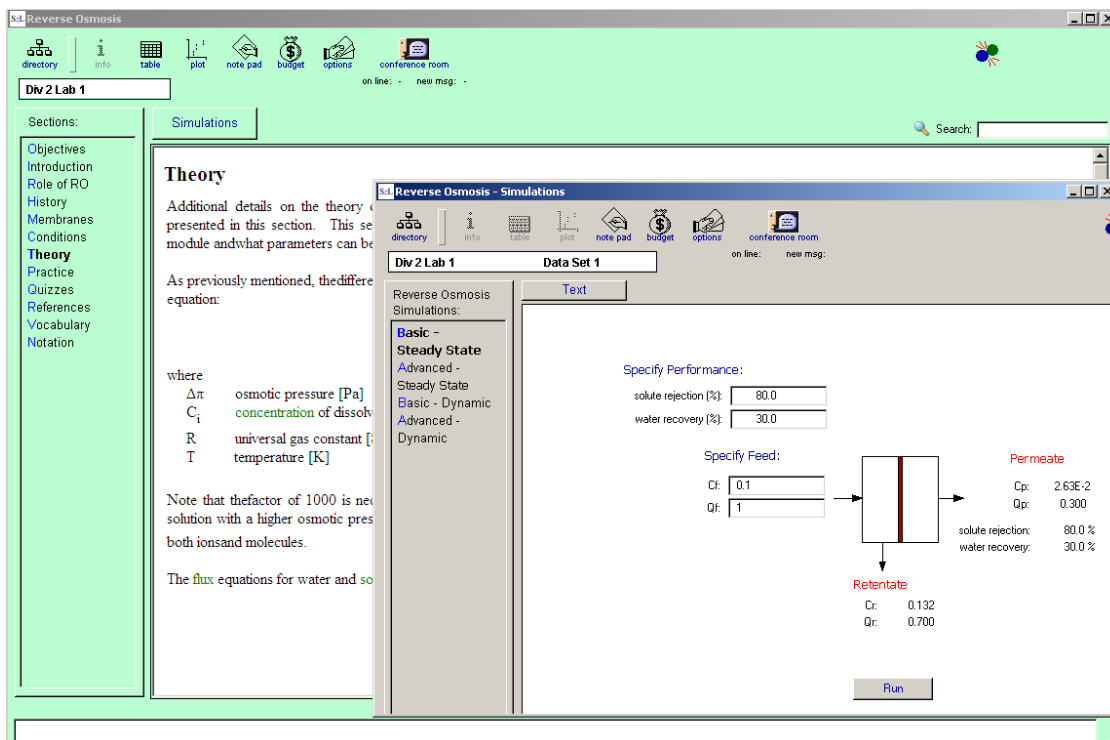


Fig. 3. Explanation window and simulation window for Reverse Osmosis module.

A more advanced simulation for reverse osmosis is presented in Fig. 4.

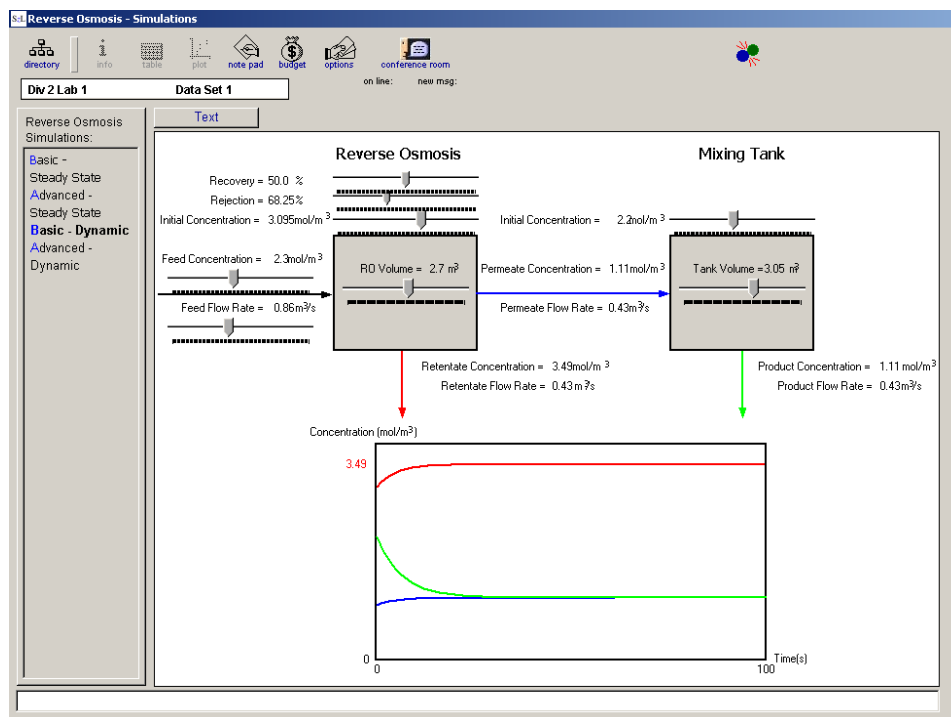


Fig. 4. Screen shot of Reverse Osmosis Dynamic Simulation.

At the start of preparing the text and graphics, we discovered that the team members at the University of Arizona wanted more control over formatting than could be provided by the development tool. Therefore, we switched to letting the authors create web pages. The web pages are rendered by the default browser on the client (Internet Explorer on Windows and Safari on Mac) in windows that are "skinned" by PureWaterLab. Any web component that can be rendered by Internet Explorer or Safari can be displayed by SimzLab.

This raises the question, "Why not distribute the complete modules as web pages accessed with a standard web browser?" The reason is that we wouldn't be able to deliver simulations with the full range of functionality that we require. In addition, SimzLab can add additional functionality not present in standard browsers. An example is that it scans pages for words in the Glossary, adds HTML tags next to the first occurrence of each word found, and displays definitions in an information field below the web page as the user mouses over the now highlighted vocabulary words.

One feature we would like to develop further is the "Conference Room." This is somewhat of a cross between a bulletin board and a chat room. It gets most active the night before a homework assignment is due at UCSD, when students ask each other for help. On one occasion, we had a three-way conversation between a professor in San Diego, a postdoctoral associate from Turkey in Ann Arbor, and an undergraduate student in Turkey.

A recent addition to PureWaterLab is a module for constructing and conducting dynamic simulations of water purification plants. The connection to the Internet allows students at different universities to collaborate on running the same plant, with one team of students operating one part of a plant and teams at other universities operating other parts of the plant.

Students can construct a process plant by adding process units and pipes to a flowsheet, as shown in Fig. 5. Material flows between units are represented in the software by messages. In Fig. 5, the blue unit on the flowsheet is the local proxy of the actual unit, which is located on a remote computer. Messages between computers are written in XML text and sent over Internet between the computers via TCP/IP sockets. Since messages between computers are in platform-independent XML text, the simulators on individual computers can be written in any computer language running on any hardware. Since the "internals" of units do not have to be known or "exposed" to users, future uses may include units posted by companies to allow students and prospective customers to experiment including a commercial unit in their process. The potential advantages of distributed dynamic simulators have been discussed by Shemeikka, et al<sup>10</sup>.

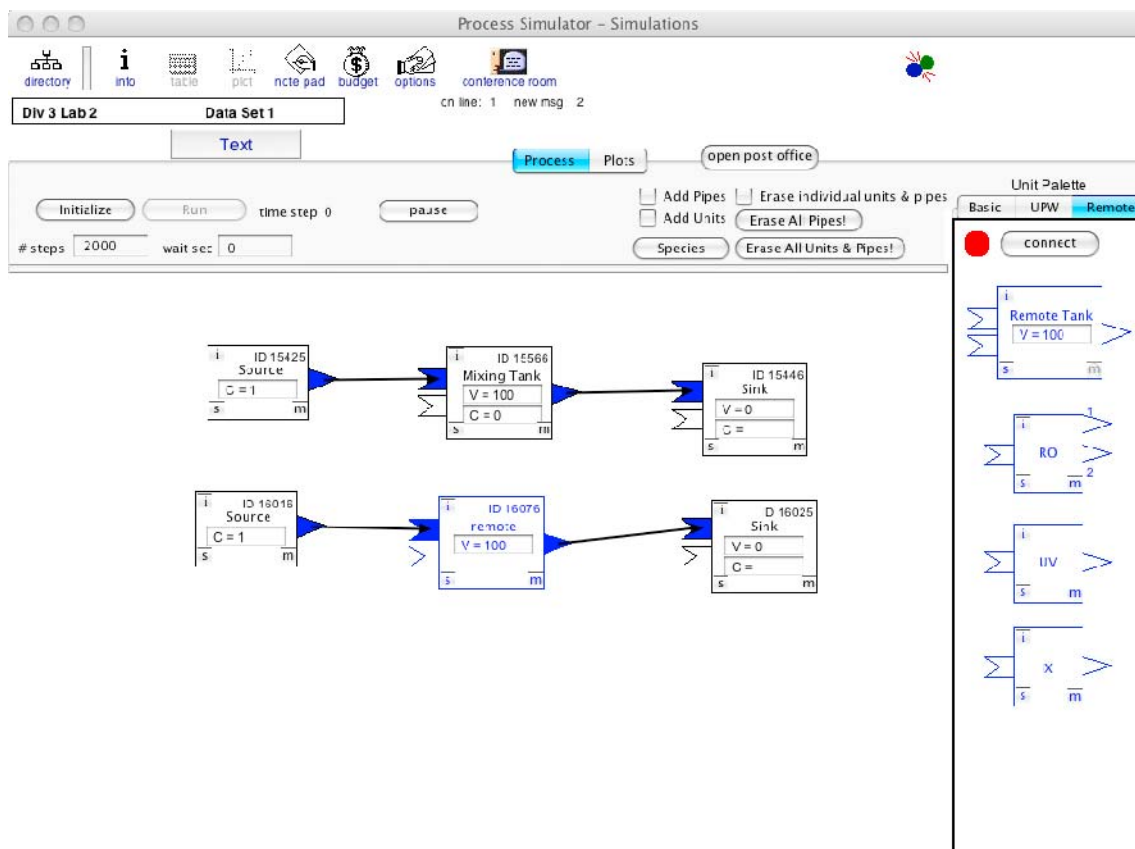


Fig. 5. Distributed dynamic process simulator in PureWaterLab.

## Acknowledgements

Development of SimzLab has been supported by the U.S. National Science Foundation through awards including DUE-0443044. Students contributing to the project include UCSD graduate student Hsu-Wen Hsiao and UA undergraduate students Erica Reiner, Chris Poole, Megan Meyer, Jason Kim, Adam Burkhart, David Bartz, and Michael Hwang.

## References

1. "Revolution" software development tool, developed and distributed by Runtime Revolution Ltd., Edinburgh, Scotland <<http://www.RunRev.com/>>, accessed February 19, 2009.
2. Zacharia, Z. (2003) Beliefs, attitudes, and intentions of science teachers regarding the educational use of computer simulations and inquiry-based experiments in physics, *Journal of Research in Science Teaching*, vol. 40, p. 792.
3. Chou, C. (1998) The effectiveness of using multimedia computer simulations coupled with social constructivist pedagogy in a college introductory physics classroom, Doctoral dissertation, Teachers College, Columbia Univ., New York.
4. Richmond, B., Peterson, S. & Vescuso, P. (1987) *An Academic User's Guide to STELLA*. High Performance Systems, Inc.: Hanover, NH.

5. Geban, O., Askar, P., & Ozkan, I. (1992) Effects of computer simulations and problem solving approaches on high school students, *Journal of Educational Research*, vol. 86, p. 5.
6. Hounshell, P.B. & Hill, S.R. (1989) The microcomputer and achievement and attitudes in high school biology. *Journal of Research in Science Teaching*, vol. 26, p. 543.
7. Grayson, D. (1996) Use of the computer for research on instruction and student understanding in physics. *American Journal of Physics*, 55, 108–119.
8. SimzLab, available at <<http://www.SimzLab.com>>, accessed February 19, 2009.
9. Pavia, D. L. (1990) SQUALOR: The design of a laboratory simulation, *Academic Computing*, February, p. 8.
10. Shemeikka, J., Klobut, K., Heikkinen, J., Sipilä, K., & Rämä, M. (2007) First Experiences with Coupled Dynamic Simulation of Building Energy Systems and the District Heating Network. *Proceedings of Clima 2007 WellBeing Indoors*.

### **Biographical Information**

Richard Herz, Ph.D. Associate Professor, University of California, San Diego. Dr. Herz teaches and conducts research in the areas of chemical reaction engineering, heterogeneous catalysis, and chemical process simulation and design.

Greg Ogden, Ph.D., P.E. Associate Research Professor, University of Arizona. Dr. Ogden is a registered professional engineer (Chemical) with over 20 years of industrial engineering experience. He has worked on numerous engineering processes in the energy, nuclear, environmental, and aerospace arenas. Dr. Ogden has brought his industrial experience to the classroom in both community college and university settings. He taught environmental science, chemistry and engineering programs at Pima Community College in Tucson for over 10 years and is currently coordinating the freshman engineering design course for the College of Engineering at the University of Arizona in addition to managing the undergraduate laboratory experiences for the Department of Chemical Engineering.

# **A Conceptual Approach to Developing a Universal Remote Laboratory for Education and Research in Electrical Power Engineering**

Hassan Mohamed-Nour

Department of Electrical Engineering, California State University, Long Beach  
Long Beach, CA 90840, [nour@csulb.edu](mailto:nour@csulb.edu)

## Abstract

One crucial element of education in electrical power engineering is the laboratory component. The laboratory instruction may be delivered in physical laboratories using real equipment or through simulation software tools, and in many cases utilizing both simulation and real equipment. Remote laboratories, where experiments are performed on real equipment remotely via simulation interfaces, have recently gained keen attraction. In this paper, a novel approach to delivering remote laboratory education is presented. The major components forming the new laboratory system include a real power system, an online monitoring and control station and a web client-server system. Sample activities that may be performed remotely through this laboratory are described. These activities range from a simple experiment for evaluation of transformer performance to more involved studies such as voltage stability and generator startup. Renewable energy activities may also be added. In addition to laboratory instruction and applied research, this remote laboratory is expected to be an ideal setting for distance learning.

## Introduction

Laboratory instruction is a critical part of a solid Electrical Power Engineering curriculum. It is well presumed that hands-on experimentation is a vital practice necessary for all graduating electrical engineers. Traditionally, the laboratory requirement in power area for most Electrical Engineering curricula involves a course in energy conversion principles covering dc and ac machines, transformers and introductory power electronics. In recent years, the use of computer simulation tools for laboratory education has been noticeably widened. However, studies normally performed on utility power systems have always been simulation-based. These include power flow analysis, short-circuit studies and power system stability among other studies. With rapid developments in computer visualization tools, virtual depiction of most engineering concepts and design methods is now possible and fairly affordable. Advances in communications and in digital signal processing and the wide use of the Internet have led to the feasibility of remote laboratories. In this case, real equipment and instrumentation may be housed in a remote location while the control of this equipment can be performed locally. Furthermore, the instrumentation and equipment can be animated locally in conjunction with real audio and video received from the remote equipment location. This virtual local animation of a laboratory is the front-end of a real laboratory which is located remotely.

## Laboratory Types

Laboratory education may be delivered via three types of laboratory settings; real, simulation and remote, each with distinctive merits. In a real lab, there is a face-to-face experimentation with real equipment. The simulation lab, however, allows working only with simulated models of the devices. Working remotely with real devices through virtual depiction of these devices via software user interfaces is termed as remote lab.

A comparison among these types has been presented<sup>1</sup>. The debate continues over the effectiveness of each laboratory type; real, virtual or remote on meeting the objectives of laboratory education<sup>2</sup>. Based on a local energy plant, an energy system laboratory was developed such that real-time data could be collected for simulation studies<sup>3</sup>. A previous work<sup>4</sup> presents a comparison between face-to-face students carrying out experiments in a real laboratory and distance students performing the same experiments in a virtual lab. It was shown that distance students were not disadvantaged compared with students working face-to-face. An internet-based approach was followed for remotely using real equipment located in multiple universities<sup>5</sup>. The role of laboratory component in power engineering education was discussed by an IEEE panel<sup>6</sup>. Further literature review indicates the tendency and favorability toward virtual laboratory mode particularly when the virtual laboratory site is linked to a remote real laboratory.

## Laboratory Description

The envisioned remote power laboratory is a small power system independent of the power grid and is composed of a set of generating buses (mostly renewable energy sources such as solar PV panels and wind power units), and a transmission system including transformers, overhead lines and underground cables. Fig. 1 shows a schematic diagram of the proposed laboratory system. Various types of loads such as induction motors with variable frequency drives can be connected at different buses. A fully coordinated protection scheme may be installed. As an essential part of this laboratory, a real-time monitoring and control system must be developed with the capability of controlling all protection and switching devices. Users of this remote lab will simply be web clients with a variable-permission protocol for monitoring and/or control of different parts of the system. Continuously updated experiments can be designed, tested and made available for use by clients.

## Sample Laboratory Activities

The following activities may be performed remotely via virtual user interfaces:

1. Transformer Performance
  - a. Record one set of instantaneous values for the input and output voltages and current in addition to their phase relationships.
  - b. Knowing predetermined values of the transformer equivalent circuit evaluate and verify the values of the input voltage and current in terms of the recorded output voltage and current.

- c. Evaluate the input power, output power, losses and transformer efficiency under the given loading conditions.
- d. Calculate the percentage voltage regulation under the same loading conditions.

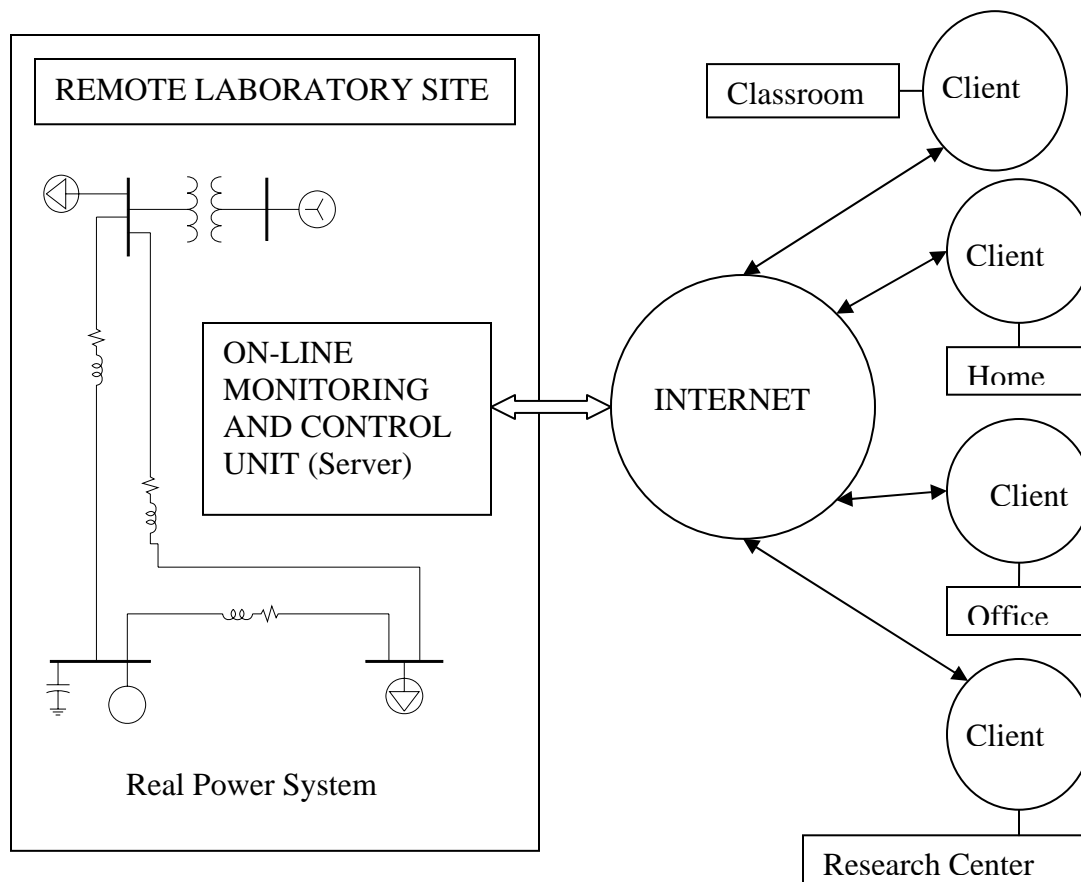


Fig. 1. Schematic view of the proposed remote laboratory system

## 2. Motor Acceleration and Variable-Frequency Control

- a. Start an induction motor under known loading conditions and record the motor parameters from start to full-speed following a certain starting method.
- b. Repeat step “a” using additional starting methods.
- c. Study the performance of the motor during starting under these different methods
- d. Vary the motor speed using a variable-frequency drive and record motor current waveforms.
- e. Analyze the harmonic contents of the motor current.

### 3. Power Flow Analyses

- a. Record the voltage magnitude at each bus at a given time.
- b. Using the values found in step “a” as initial values, perform the load flow study.
- c. Compare the simulated output results with the real-time data shown on the virtual interface.
- d. Study the significance of line losses and voltage drops on various branches under different loading conditions.

### 4. Short-Circuit Analyses

- a. Perform a pre-tested short-circuit scenario and observe the operation of various protection devices.
- b. For the conditions of “a”, perform a simulated short-circuit study.
- c. Repeat steps “a” and “b” for other pre-tested short-circuit studies.
- d. Compare the simulated output results with the real-time data recorded.

### 5. Device Coordination Study

Using a radial primary distribution feeder, coordination of various protection devices may be presented. Real time performance of the relays both as primary operations and as backup operations may be tested.

### 6. Voltage Stability

Voltage instability occurs due to primarily the lack of sufficient reactive power support. Susceptibility of any bus to voltage collapse can be studied by evaluating the sensitivities of the voltage at these buses to changes in the injected reactive power. Other dynamic factors may be investigated as well.

- (a) Select a load bus to undergo a voltage stability test.
- (b) Monitor and record bus voltages in addition to active and reactive power flow
- (c) Vary incrementally the load at this bus until the voltage collapse occurs.
- (d) Evaluate the voltage stability sensitivity indices.
- (e) Study other factors that may influence voltage stability.

### 7. Emergency Generator Start-up

Another importance experiment for power engineering students is bringing up a backup generator online. Whether triggered by a loss of power signal or a manual startup case, there are certain conditions need to be met before actual connection occurs. This experiment may be designed such that the conditions for a successful startup be monitored and analyzed, then, a command for execution is sent. One condition to verify is that the loading condition (both real and reactive power) during startup allows a valid generator operating point.



## Renewable Energy Activities

Other activities may also be added to include renewable energy links. For example, a photovoltaic panel system can be a part of an experiment covering the maximum power point tracking process. An experiment aiming at power conditioning from a wind generator as well as its overall performance is another example.

## Concluding Remarks

A universal remote laboratory has been suggested for education and research in the area of electrical power engineering. The conceptual laboratory offers unlimited expandability to cover a wide range of topics and educational experiments. Working with a real system in addition to advanced visual animation technologies, users are expected to gain immense doses of practical experience. A cost analysis for a start-up practical system is yet to be performed.

## References

- [1] H. Mohamed-Nour, "Simulation and Virtual Laboratory Education in Electrical Power Engineering," AEAS Conference Presentation, Cairo, Egypt, December 2008.
- [2] J. Ma and J. Nickerson, "Hands-On, Simulated, and Remote Laboratories- A Comparative Literature Review," ACM Computing Surveys, Vol. 38, No. 3, Article 7, September 2006.
- [3] C. Gooding, J. Hinson and D. Stubblefield, "Clemson University's Energy Systems Laboratory: A Hands-on Learning Experience for Students and Faculty," Energy Engineering, Vol. 103, No. 2, 2006
- [4] R. Blanchard, S. Moron-Garcia and M. Bates, "Converting the physical to the virtual: providing a laboratory experience for distance learners in engineering," Current Developments in Technology-Assisted Education, FORMATEX 2006.
- [5] M. Albu, K. Holbert, G. Heydt, S. Grigorescu and V. Trusca, "Embedding Remote Experimentation in Power Engineering Education," IEEE Transactions on Power Systems, Vol. 19, No. 1, February 2004.
- [6] L. Sevg, "Modeling and Simulation Concepts in Engineering Education: Virtual Tools," Turkish Journal of Electrical Engineering, VOL.14, NO.1 2006,

## Use of Concept Maps to Build Student Understanding and Connections Among Course Topics

Paul Blowers  
The University of Arizona  
Department of Chemical and Environmental Engineering

### Abstract

Students often have a difficult time becoming strong engineering students because they are used to some of the prerequisite courses in science and mathematics being somewhat formulaic and "plug-and-chug" in their approaches. When students have been challenged by prior courses that are not formulaic, they often rate them as being harder or complicated. The transition of becoming more broad-thinking in problem approaches is a difficult one, even for very hard working and bright students. Concept maps enable instructors and students to more concretely describe connections among different course topics and to place new knowledge into a comprehensive problem solving framework.

Examples of concepts maps from a series of chemical engineering courses are used to discuss how the idea of concept maps can be used in different ways. Concept maps built over the semester for a sophomore material and energy balances course are used to highlight how layering of new concepts and an inherent increase in complexity leads to a comprehensive overview of material. Use of the concept map in lecture example problems demonstrates how one can utilize the given problem statement to see how solutions to conceptually challenging problems are built. A concept map from an equilibrium thermodynamics course at the junior level is used to show how disparate yet interrelated ideas can be bridged together through a hierarchical definitional approach. Finally, a concept map illustrating sustainability in the context of technical, social, economic, and environmental issues for a senior design series is examined for pedagogical relationships on why certain topics were selected for the courses.

Student feedback has consistently shown that the idea of concept maps enables students to solve more complex problems with greater confidence. Students have also indicated that they have developed concept maps for subsequent courses on their own, even though it was not required and instructors did not encourage these efforts. Students seem to benefit from these activities.

### Introduction

Faculty in engineering often suspect that prerequisite courses in science and mathematics are focused on formulaic approaches to solving problems. This is sometimes called the "plug and chug" method where students may not understand the fundamental concepts but will superficially link mismatched concepts together, leading to poor performance in the prerequisites and a weak foundation for building the core engineering topics. Sket and Glazar observed high school chemistry students who did not organize their knowledge, knowing the individual reactions, but not how to link a series of reactions together<sup>1</sup>. Students in the prerequisite science courses, then, may be attempting to learn more superficially than what will be required of them later on. This view of teaching and learning fits well with an investigation of how some faculty

see teaching as transmitting information and students learning as receiving this information<sup>2</sup>, without much focus on how the information really functions. The work by Hendersen, et al., used a focal problem from physics to investigate faculty perceptions of teaching and learning problem solving where the problem would require an average student to use exploratory decision making as opposed to an algorithmic or "plug and chug" approach. A significant number of faculty viewed their role as a knowledge transmitter and not a problem solving enabler.

Much of the material in prerequisite courses prior to the beginning of core engineering courses is oriented towards factual recall. It is on these foundations that the engineering problem solving skills will be built. Ausubel's theory of assimilation<sup>3</sup> points out that linking to prior knowledge is a key to building long lasting and useful skills. In essence, knowledge must be organized in order to be accessible from long-term memory<sup>4</sup>. Students who possess isolated information about concepts on a factual basis will remain novices and be unable to solve complex problems.

Students often have difficulty transitioning from fact recall courses to more integrated and informationally cross-connected courses in engineering. This may be because students have yet to learn how to create a scaffold for holding new information in a coherent whole where topics are related to each other. Concept maps may be one way of enabling students to succeed in overcoming this difficult transition to problem solving and critical thinking.

#### Concept maps and their history

A recent meta-analysis of concept and knowledge maps points out that diagrams like these originated as far back as the 13th century<sup>5</sup>. However, their use has seemed to explode recently with a much larger number of publications appearing in the literature. Even just since 1997, there have been 500 peer-reviewed articles that have investigated their use, according to a brief survey of Journal Citation Index.

Novak<sup>6</sup> proposed the concept map as a way of created a knowledge network that contains points and vertices as concepts and links between them as the relationships among concepts. Kinchin and Cabot point out that there have now been 25 years of extended research and development of using concept maps to help students learn how to learn<sup>7</sup>. Essentially, concept maps are two-dimensional representations of a set of concepts and their relationships<sup>8</sup>. Being graphical in nature, they show the conceptual, relational, and hierarchical nature<sup>9</sup> of topics in a course or series of courses.

#### How instructors use concept maps

Concept maps have a rich history of application in the medical education literature<sup>8-10</sup>. For instance, concept maps have been used to evaluate student learning of CD-ROM based educational materials in MRI imagining<sup>10</sup>. Hay, et al., showed that concept maps could be used, even in small classes of only six medical students, to investigate how deeply and richly students perceived new topics after a short-term assignment requiring use and assimilation of a 6-8 hour long electronic teaching tool that covered both case studies and more rote learning through a tutorial. Students drew a map of their pre-knowledge of MRI technologies and then drew a second one after exposure to the material. Students were evaluated on the structural changes in the hierarchy of organizing concepts, their use of expert terms, and then through a blind-evaluation of the pre- and post-mapping exercises. Of the 78 concepts detailed by instructors,

only 28 showed up on any of the student maps, and at that, only half of the module sections were represented. It was noted that preknowledge of the material or prior experiences were a very strong determinant of the final concept map structure. The authors ended with a suggestion that the concept maps may have wide-ranging utility that may help some students more than others, particularly noting that concepts maps were a visual representation of linkages between material.

Diwakar, et al., used concept maps extensively to teach physiology to veterinary students<sup>11</sup>. Their work was motivated by the fact that concept maps provide a visual road map showing how students may connect meanings of concepts together. The authors expended effort developing assessment tools for evaluating student-constructed concept maps. A preliminary study of their method was done with freshman students who were graded on maps they had drawn. Forty-eight percent of the students reported liking the concept maps, but 28% did not like them. The authors went on to use concept maps extensively as a student assessment tool in a first-year veterinary medical school course on physiology. The course consisted of two exams, seven quizzes, and 11 concept-mapping assignment in addition to five laboratory reports. The concept mapping exercises constituted 17.5% of the total grade in the course. Students were surveyed about their likes and dislikes of the concept maps and only 21 % reported liking concept maps, but 81 % felt that concept maps helped them understand material and 68 % thought it helped them organize information. So, while students don't like them, they self assess themselves to benefit from them, indicating there may be some resistance to using concept maps as an assessment tool. Students reported spending about 3 hours in developing a satisfactory concept map and that it took them an average of 3.3 attempts to create one they liked.

Kaya discusses using concept maps to evaluate the changes in the conceptual understanding of 47 prospective science teachers in a general chemistry laboratory class<sup>8</sup>. Their goal was to develop assessment tools that would prove the acquisition of higher-order thinking processes instead of just factual recall and basic skills. The structure of the course was a 15 week long semester with 3 hour labs. Students spent one semester prior to the one with this course learning how to develop and use concept maps and then they were evaluated on their concept maps in the course. Students were asked to individually prepare concept maps prior to the laboratory exercises and then they performed peer evaluations of each other's maps. After completing an experiment, students again did their own maps and then peer evaluated each other. Expert evaluation of the pre- and post-lab concept maps allowed for an examination of how deeply students were learning the material, and the author found that for almost all topics, students developed concept maps that were more interconnected and complete after the experiments. Quantification was difficult to score and the process of evaluation was very cumbersome in that work.

Moni, et al., worked with second year dentistry students to explicitly teach concept maps to facilitate meaningful learning for a four week long segment of the course on cardiovascular, respiratory, and renal systems. Concept mapping exercises and scores contributed to six percent of the students' final grades. During the four weeks, students participated in a 50 minute long introductory workshop on concept maps on other topics. Students were then given a case study where they worked in a team for 1 week to make a concept map detailing the interrelationships between different concepts and the case study. The 1 week time period included a 2 hour workshop where students discussed their work with the faculty members. Two faculty members

then evaluated the concept maps with a complex quantitative scoring system, discussed differences in their scoring, and then led mediated discussions with the students to arrived at the final grades. Finally, students were given a survey about their experiences and 42 % of the students felt that concept maps help put everything together linking multiple concepts, but 40 % thought the exercise was too time consuming but worth the effort. In a follow up work, the authors used their newly designed assessment rubric and investigated student opinions of the tool more<sup>12</sup>. They found the concept mapping activities were not favored by students but that their like/dislike of the tool correlated with their grade.

Schau and Mattern discuss additional uses for concept maps other than in assessment<sup>4</sup>. They point out that instructors can use them in instructional planning, which will be discussed later on in this work, and as learning tools. Concept maps are effective learning tools both when given to students and when created by students. As discussed before, creating concept maps forces students to attempt to organize information. However, having concept maps provided allows the students to see a hierarchy or overall structure to which they can anchor new concepts within the framework of their own understanding. Schau and Mattern also discussed some quick and efficient methods of using concept maps that have not been discussed in the other works, which is to use them as a template where varying degrees of node identifiers or links have had their labels removed and students must fill in the missing information. This can be done either without providing them with the missing information or by also giving them the list of information to be added. These instruments are extremely easy to evaluate compared to the previously described assessment tools.

Kinchin and Hay showed one could use preliminary concept maps to aid postgraduate trainee teachers learn aspects of biology<sup>13</sup>. They used the preliminary maps to build teams of students who then worked collaboratively to flesh out more complete maps that detailed the topics. The students received 2 hours of concept map training followed by developing individual maps and then creating a group one. The authors described three types of concept maps to elucidate how to build the teams, spokes which were very straightforward, chains, which only had linear connections among ideas, and nets, which had more node connections among different levels. These net diagrams can be used to employ technical terminology to enhance meaning, in their view, and it is nets that will be used later in this work. They pointed out that concept mapping tools for learning are often underutilized, but do not discuss, much as others have, how one can actually use concept maps to enhance deeper problem solving skills instead of just in building a fact/knowledge diagram.

Pre- and post- exposure to material concept maps were used by 32 freshman students in evaluating self-awareness of limitations of missing knowledge of computer hardware<sup>14</sup>. Students drew one concept map on their own regarding the material using a somewhat constrained computer-based tool before comparing their maps to those of their peers. Students then redrew their own maps. Pre- and post-maps were evaluated by three experts who were trained with the same computer-tool and with the same terminology. Unfortunately, only 25% of the students thought the mapping procedure helped them find conceptual faults.

Kinchin and Cabot point out that there has been a shift towards PowerPoint based lecture materials in many disciplines<sup>7</sup>. Unfortunately, much of the information presented in the

PowerPoint format is organized in bullets that are sequential in nature, often burying connections among topics in the details of the sequences. However, concept mapping promotes integrated knowledge structures using multiple perspectives that are focused on meaningful learning. In their short work, the authors used PowerPoint-based concept maps to supplement learning for 37 third year undergraduate dental students in a section of a course dealing with the problem solving aspects of developing a partial denture design. Students were given two separate PowerPoint slides, one that was a traditional bulleted format of the information and another that was a concept map showing relationships between content. Ninety-two percent of students reported that the slides in the bullet-point format helped in memorization while only 43% said this of the concept map format. However, 95% of students felt the concept map helped show connections between individual concepts. Unfortunately, there was no evaluation of whether student perceptions carried forward to improved performance.

Another paper pointed out that instructors could use concept maps to help students better tailor their instructional approaches in e-learning environments<sup>15</sup>. The paper then went on to develop fuzzy logic analyses to automatically generate concept maps for courses using student performance on exams as a guide. The generalizability of this approach may not be feasible for open-ended engineering format questions and material.

Creating access to prior knowledge and activating students to be receptive to new linkages was explored by Gurlitt and Renkl with 43 high school and 45 university students using physics as the subject matter<sup>16</sup>. The premise is that students primed to access prior knowledge would be more involved in developing deeper linkages among concepts on a particular topic. The experiment was very short in duration, approximately 1 hour and 15 minutes, where students were exposed to the idea of concept mapping, given a partially constructed expert map, and asked to fill in additional information. After that, students were given access to web-based textual materials that explored different topics. Students then took a post-test of the material and contained both open ended and multiple choice questions. While there were many inconclusive results, the authors found that there was enhanced learning after use of the concept map to activate areas of prior knowledge and prerequisite material.

Development of concept maps was linked with learning styles in a study of 120 nursing students<sup>17</sup>. Again, the main theme in nursing like in engineering education, is to develop critical thinking skills in students which includes interpretation, analysis, evaluation, and inference with the ability to provide the rationale for one's judgment. Concept mapping was proposed to be a method of evaluating meaningful learning on the basis of Ausubel's<sup>3</sup> assimilation theory. In the study, students were invited to participate, which may have led to some self selection effects. Data collection was brief, with two 10 minute assignments during the semester, one to complete a learning styles survey instrument and one to complete a concept map. Concept maps were then evaluated by faculty members using an internally consistent peer comparison ranking process, which may have had some subjectivity. The learning styles groupings did not include a visual-verbal category so it is interesting to consider whether the inclusion of this type of axis from Felder's work<sup>18-21</sup> would have led to stronger correlations. In the nursing work<sup>17</sup>, abstract learners were twice as likely to have preferred using concept maps over more traditional case study materials. The authors ended with the idea that concept maps may be more effectively used as teaching tools than as grading or evaluation assignments.

Only one paper in the literature surveyed by the author discussed using concept maps as a teaching tool as suggested in the previous paragraph, and that was the work of Sket and Glazar<sup>1</sup>. The authors lay out a hierarchical detailing of organic chemistry syntheses reactions using oxidation/reduction mechanisms as one axis and individual reactions along the other axis. The authors then show one example of how one could use their concept map to answer a fill in a homework exercise, leading the reader through how to use the concept map. They give a few other simple examples that would rudimentarily benefit from the concept map. They end with the thought that elaborated concept maps enable students to integrate concepts successfully.

A meta-analysis published in 2006 examined 55 studies involving 5818 participants ranging from elementary school age through post secondary education participants<sup>5</sup>. The study broke the studies up into several major categories in their analyses, finding that concept maps aided in instructional goals and student learning in almost all situations, at all age levels, in all contexts. In particular, student construction of concept maps appeared to be very useful, although even just studying a preconstructed concept map led to some educational achievement enhancement. Working on concept map development also appeared to improve learning outcomes in collaborative learning and peer interaction exercises. The authors mention early in their work that concept maps may aid learners because verbal knowledge and mental images reside in separate but interlinked memory units. This is interesting in light of Rich Felder's work on identifying the visual/verbal axis in his learning styles assessment materials<sup>18-21</sup>.

Anecdotal information from the author's surveys of students over a 10 year period have revealed that about 90% of honors freshman at the home institution are visual learners, indicating that text only materials may not be the best way of fostering student learning, even among very high achieving students. A visual representation of connections between topics on a concept map is also easier in identifying links compared to scanning and re-reading text only materials. The authors of the meta study<sup>5</sup> go on to suggest that maps may be useful because they reduce the difficulties in placing new material into the context of pre-existing knowledge. This may be due to the visualization engendered by the representation of the material

The meta-analysis<sup>5</sup> points out there is a strong need for assessing learning outcomes beyond conventional free recall and research-constructed achievement tests, which are primarily multiple choice or short answer assessment tools. The authors suggest that more work should be done to examine how students learn with concept maps and their effects on higher learning goals, such as problem-solving transfer, application, and analysis.

#### How students use concept maps

From a learning perspective, concept maps may enhance learning when used to summarize information<sup>5</sup>. Maps may be good for acquiring main ideas but may do poorer at helping students acquire detailed or nuance-laden knowledge and this may have some interesting impacts on how concept maps can be used effectively. Additionally, maps may be easier to comprehend for learners who are studying in a non-native language, possibly enabling them to draw larger inferences quickly even with language comprehension impediments. This may have implications for engineering students where large numbers of undergraduates now come from overseas.

Hilbert and Renkl did one of the more involved studies of investigating concept mapping strategies as a method for students to integrate textual information about a new topic<sup>22</sup>. Thirty eight university students were asked to read a series of articles about stem cells taken from newspapers. They were then asked to verbalize some statements about them, asked to then make concept maps of the information from the articles using a software tool for 30 minutes, and then redraw the maps after rereading the articles. The students were then given a multiple choice test and an open ended question about stem cells. In addition, students took intelligence tests that were designed to assess their verbal skills and their spatial/visual skills. The authors correlated information to answer a series of hypotheses. This is one of the few prior studies that have looked at visual abilities as related to the use of concept maps. Sixty-three percent of the students in the experiment had not been exposed to concept maps prior to this exercise. Students, in general, had learning increases on the multiple choice questions after reading the articles and doing the maps regardless of their spatial or verbal skills. However, on the open ended integration question, visual learners scored higher.

Finally, it is interesting that in most concept map applications, students have been asked to either construct concept maps or have been asked to study content on them. To this point, there has been no work on actually using concept maps to foster development of problem solving skills in the context of real problems.

### **Approach in this Work**

The author of this work has long been involved with exploration of educational techniques of fostering student learning in both breadth and depth of their abilities to reach mastery of material. The topics integrated so far have included use of web-based interactive problem solving tools online<sup>23</sup>, enabling freshmen students to transition effectively to college<sup>24</sup>, creating syllabi that foster communication among faculty and students<sup>25</sup>, information literacy<sup>26,27</sup>, integrating sustainability into senior design<sup>28</sup>, and predicting sustainability metrics through quantitative measurements<sup>29</sup>. In addition, there have been other papers on the arguments for a straight grading scale in engineering<sup>30</sup>, the balance between teaching and research at different institutions through a quantitative investigation of pedagogical publishing<sup>31</sup>, and forming balanced teams through students' self assessments of their own abilities<sup>32</sup>. This summary is included here because some of the themes that have emerged over time bear on this work and show that creation of concept maps and their use is logical. The interfaces among the different educational topics will be discussed where appropriate. Much of the work on integrating new learning and teaching approaches was done to foster learning for students with different learning styles.

Felder and coauthors, as previously described, have long explored different learning styles for students and teaching styles of faculty and how those interact for student success<sup>18-21</sup>. In relation to this work, students who learn best from global approaches may find the use of concept maps useful in synthesizing a coherent framework on how new material is connected together. Sequential learners, the other end of the global-sequential continuum, may find that they can piece together longer chains of problem solving events when they can see more complex interconnections than sequential trial and error may allow them to experience. Visual learners may also find the map format more useful than verbal descriptions of connections. In the context



of these learning styles, there have been three major uses of concept maps in courses taught by the author that will be highlighted using examples from the most recent offerings of each course.

### Sophomore Material and Energy Balances

In the sophomore material and energy balances course, there were a total of 94 students who finished the course out of the 103 who began the course at the beginning of the Fall 2008 semester. This course is the first core course in chemical engineering and is one of the two options engineering management students must take in order to meet their energy-based curriculum content requirements. Students in engineering management may take this course during their sophomore, junior, or senior years, while chemical engineers will be sophomores.

A variety of instructional support tools were used in this course that had an impact on the use and evaluation of concept maps in student learning. These tools were primarily computer-based and included the use of Desire to Learn (D2L), a comprehensive tool for organizing course information and tracking student use of online content, the use of OneNote, a powerful software program that utilizes PCTablet technology to allow one to write on a virtual notebook page while archiving verbal statements made during class, and Microsoft Excel, Word, and Powerpoint files posted on D2L.

The primary use of concept maps in this introductory course was to facilitate student integration of new concepts into a coherent framework that allows them to solve complex problems. Because this class is oriented towards solving unique and new problems as opposed to being "plug-and-chug", this may be the first time that students are forced to integrate complex material at a deep level. Prior to each exam after the second exam, an integrated picture of interrelationships was constructed that showed how the complexity of the material grew while branches leading among disparate areas allowed one to handle more phenomena. Additionally, late in the semester, concept maps were used in the context of individual problems to help students organize the given information and begin formulating solutions. Samples are shown later in this paper.

### Junior Equilibrium Thermodynamics

The core second thermodynamics course in chemical engineering at the University of Arizona contained 38 students who completed the course out of 39 who began the course in Spring of 2008. This course is in the fourth semester of core courses so students should be strong problem solvers at this point in their academic careers.

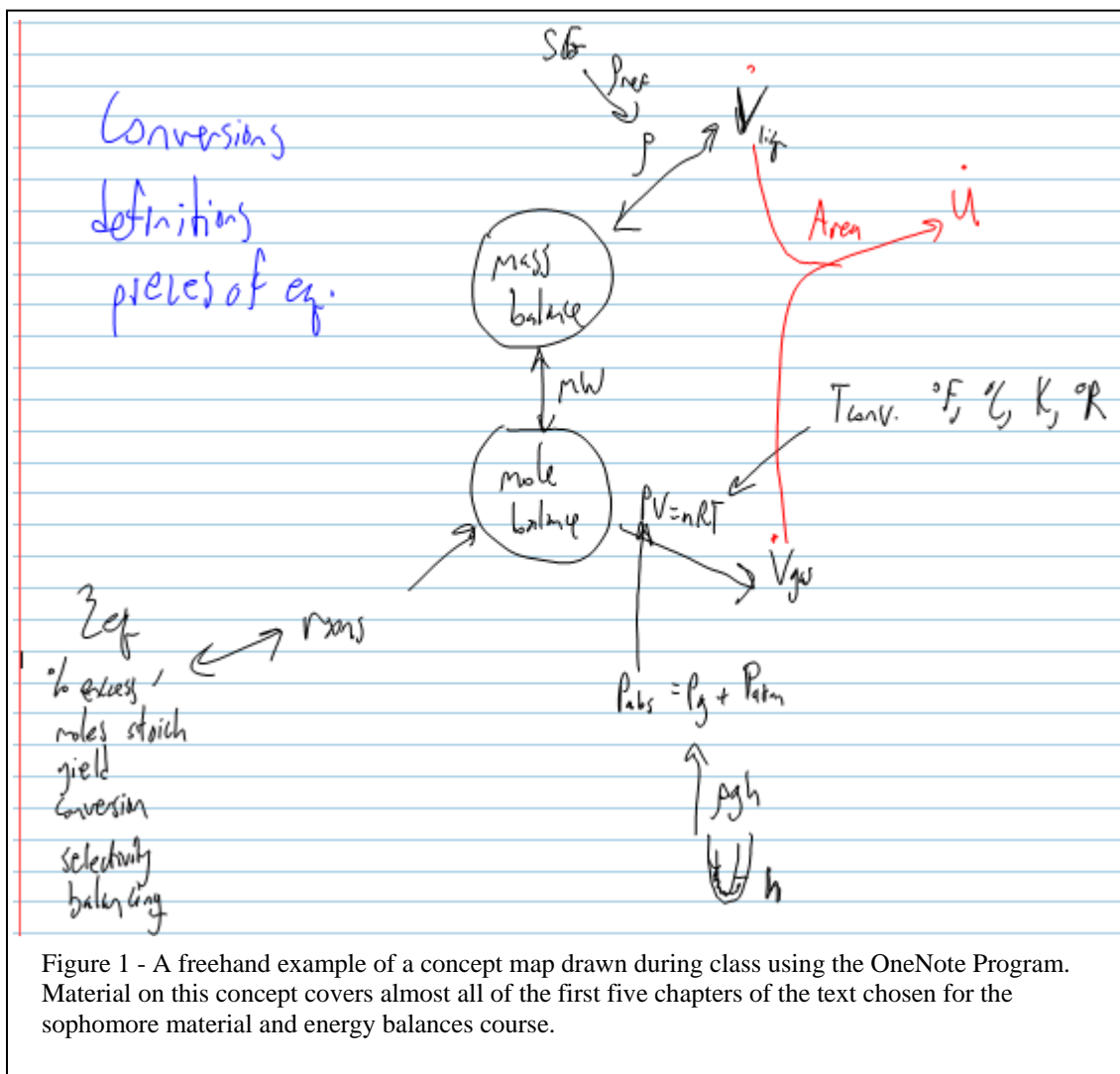
The concept map shown later was originally constructed by the author the first time they were the instructor for this course. In many institutions, the equilibrium thermodynamics course becomes a repository of topics that may not fit together into a coherent whole and the author struggled to synthesize the connections between the seemingly disparate topics. With the core relationships worked out, it then became possible to connect all of the material rationally while also building an end of the semester project that required students to use the interconnections between course content.

### Senior Design

The senior level chemical engineering class in the Fall semester of 2008 had 36 registered students who began and completed the course. Senior design at the home institution has undergone many changes over the last several years<sup>33</sup>, the largest change being the integration and distribution of sustainability and related topics into the senior design series. The third year after this integration was done, a concept map was constructed to help students see how sustainability of technologies and decisions could be affected by social, economic, technical and environmental issues. This concept map is shown later on in the results and discussion.

### **Results and Discussion**

Concept Map Uses and Details: Figure 1 on the next page shows a sample of the concept map first included in the sophomore course lecture, drawn in real time with students generating the concepts that showed up on course objectives while the instructor linked the concepts together prior to an exam. The figure is a screen shot from the OneNote program which functions as a computer-based notebook where one can draw freehand or type in information. This concept map outlines the first five chapters of Felder and Rousseau's Elementary Principles of Chemical Processes<sup>34</sup> text typically used with beginning chemical engineering students.



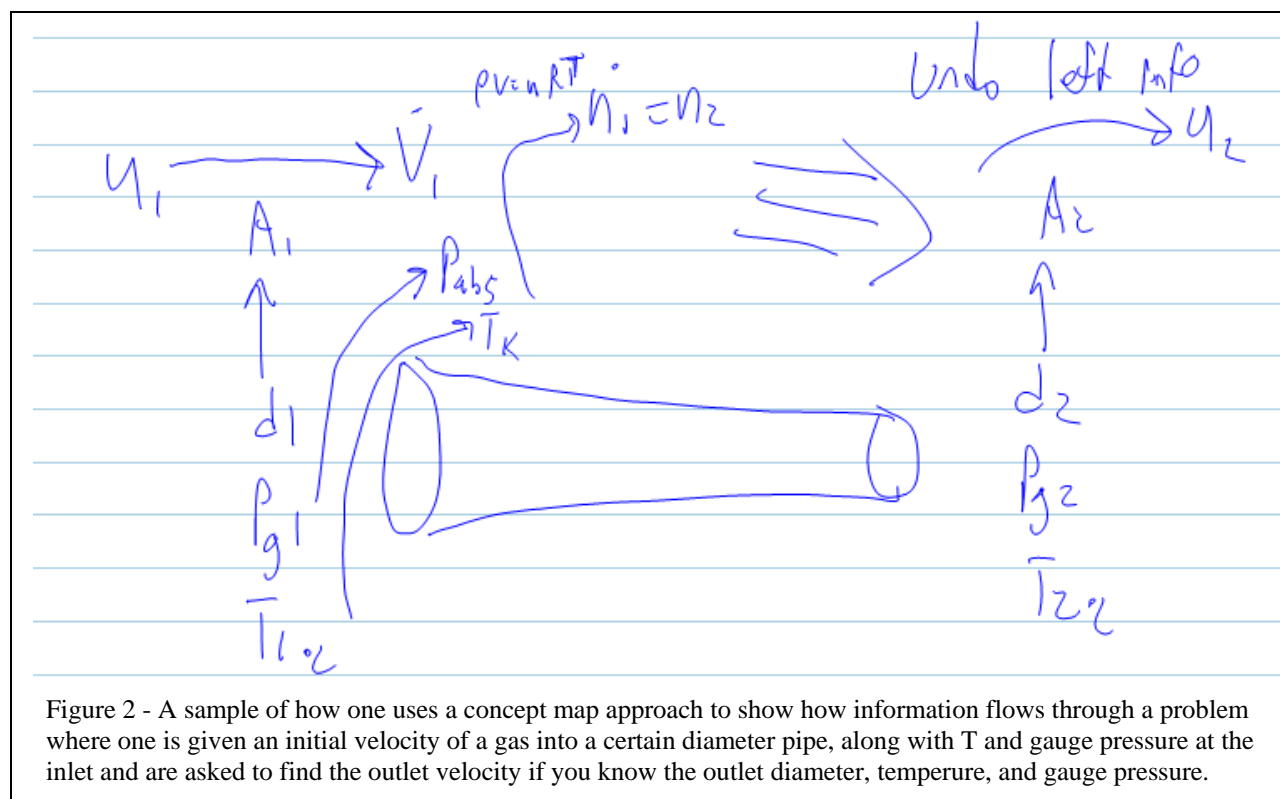
The concept map includes information about basic variable transformations like using specific gravity (S.G.) on the top of the diagram to convert to density ( $\rho$ ) using a reference density ( $\rho_{ref}$ ). Density can be used to convert from mass balances, represented in a circle as one of the fundamental cornerstones of the course, with volumetric amount of flowrate, represented as  $V\text{-dot}$ . In the center of the diagram, mass balances are connected to mole balances through the molecular weight (MW) link that interconverts between those two ideas.

In Figure 1, there are two major branches off mole balances. The one on the left labeled reactions (rxns) leads down to a laundry list of concepts and definitions that students should be familiar with from chapter 4 in order to be successful in problem solving. Another major branch leads down to the right from mole balances through the ideal gas law ( $PV = nRT$ ). Some feeder information from the bottom of the diagram includes manometers, represented with the letter  $h$  for height difference between manometer fluid levels. This information is transformed through a gravimetric analysis ( $\rho gh$ ) to pressure, which can be used to relate gauge to absolute pressure through atmospheric pressure. It is absolute pressure that must be used in the ideal gas law. The

ideal gas law can be used to convert moles to volumes for gases, often requiring some temperature conversions shown on the right side of the figure.

The final concept on the map is velocity represented with  $u\text{-dot}$  in the upper right of Figure 1. The velocity can be found from knowing the volumetric flowrates of either liquids or gases and the cross sectional area for flow. At this point in the course, students now had a concept map that linked the flow of information for different problems that can be covered using topics from chapters 1-5. In the upper left of the figure, there are some other concepts that overlay all of the problems and indicate core knowledge that must be assimilated in the context of the rest of the map. One needs to know how to manipulate unit conversions, how to use definitions properly, and how to understand what different pieces of equipment can do and how to model them.

Figure 2 shows how one can solve a simple problem using a concept map approach to indicate how information moves and in what order calculations can be done.



In the above problem, one is given the fact that a gas is flowing through a tube that has a decreasing diameter. The inlet and outlet conditions are given but students need to find the final velocity. Students need to figure out that they transform the given diameter of the pipe into a cross sectional area for flow, which is multiplied by velocity in the upper left of the diagram to get volumetric flowrate. In order to use the ideal gas law to get the number of moles flowing through the tube, one needs to convert the temperature to degrees Kelvin from Celsius and the gauge pressure to absolute pressure. One then uses the concept that the number of moles flowing into the tube must be equal to the number of moles flowing out of the tube. The entire right side of the diagram is then a pictorial representation of how the same information and calculations

flow backward in a symmetrical way to yield the outgoing velocity. This concept map shows how a single problem can focus discussion on connection.

Figure 3 shows another example from 10-26-08 where a concept map was used in the sophomore course to show how information flowed through a problem towards an answer. The problem in this case is a classical example in chemical engineering where the inlet volumetric flowrate of a gas to an air conditioner is specified in addition to the temperature and pressure. The question then requires students to solve for the amount of water that would be condensed out from this air as it is cooled. The concept map shows that one uses the ideal gas law to find the molar flow ( $F_1$ ) of the gas. One then uses the temperature to solve for the vapor pressure of water  $P_w^*$  on the bottom of the figure. One assumes the total pressure ( $P_{tot}$ ) stays constant and that only pure water is being condensed  $x_{2,w} = 1.0$ . This allows one to find the molar composition ( $y_{3,w}$ ) of water in the exiting air using Raoult's law. At this point, one must solve two equations with two unknowns to arrive at the answer. This is typically a complex enough problem that many students will be lost by the end of the solution. In this instance, the problem was sketched and the equations were sequentially solved. After completion of the example, this concept map was drawn as a summary of the steps to connect the answer to the information stated in the problem.

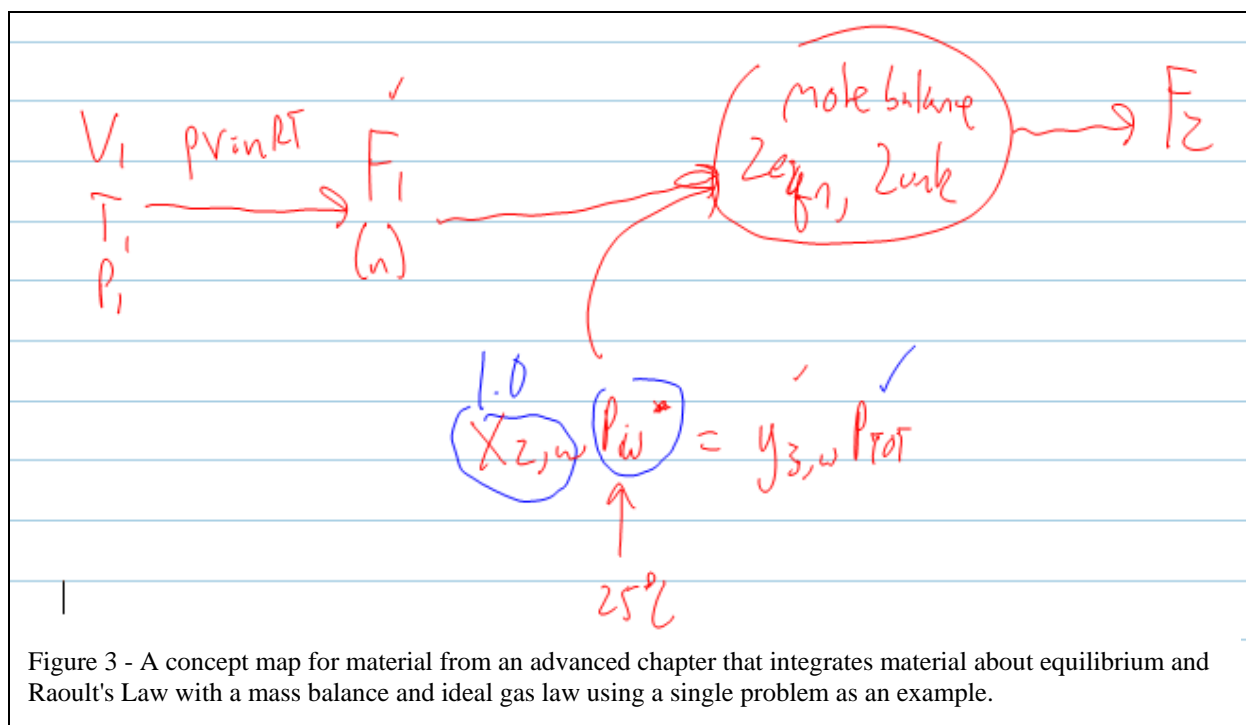
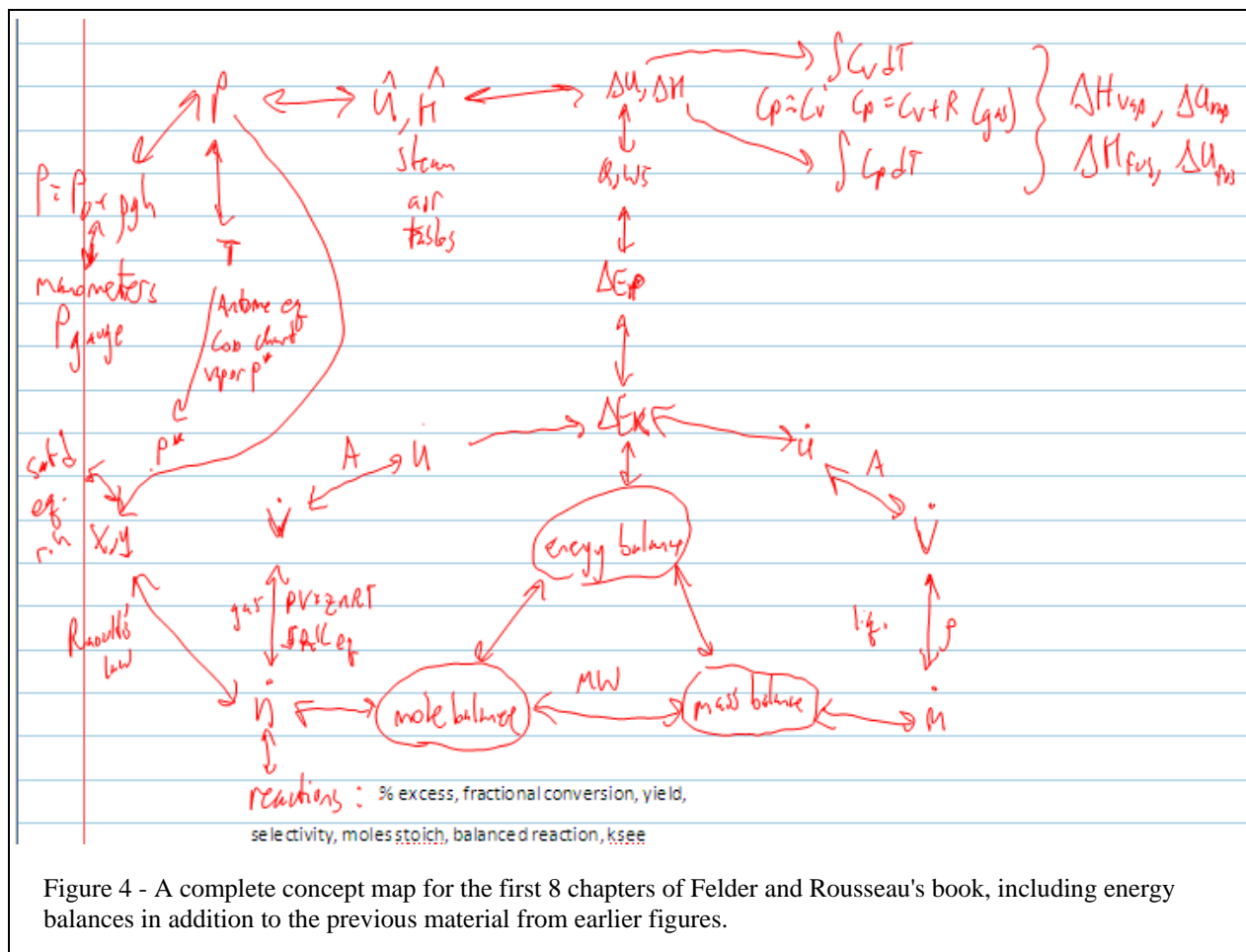


Figure 4 shows a complete concept map for the entire course's material up through chapter 8 of Felder and Rousseau, which is the final chapter covered. One now sees that much of the information from earlier figures has been redrawn and that there is a new locus of connections on this diagram, which is for energy balances that are used to complement the mass and molar balances.



There are some more details that are included now. The addition of Raoult's Law seen in the previous example and the vapor pressures ( $P^*$ ) coming from Antoine's equation, Cox charts, or vapor  $P^*$  tables have been added on the left near the manometer information. Some definitions regarding relative humidity (r.h.) and saturation (satd eq.) have also been added that lead to mole fraction concentration relationships ( $x$ ,  $y$ ), that then feed into moles and mole balances through the lower left portion of the diagram.

Energy balances appears as the third core concept in addition to mole and mass balances. And now, since there is some symmetry to the diagram to get from moles or mass up to velocities that then feeds into the kinetic energy term of energy balances, you end up with two pathways through volumetric flowrate using area to get to that point, one for liquids and one for gases. Potential energy, heat ( $Q$ ) and shaft work ( $W_s$ ) also appear leading up towards the top of the diagram where internal energy ( $\Delta U$ ) and enthalpy ( $\Delta H$ ) appear. One can then bridge over to specific internal energies and enthalpies ( $U$ -hat and  $H$ -hat) to the left through temperature and pressure information. One can also calculate enthalpies and internal energies from integrals of the appropriate heat capacities in the upper right. Phase change information may also be needed through  $\Delta H_{\text{vap}}$ ,  $\Delta H_{\text{fus}}$  and  $\Delta U_{\text{vap}}$ ,  $\Delta U_{\text{fus}}$ . It should be noted that even after several years of using concept maps in the course, the instructor still made three attempts to reach this final form that seemed most clear.

Figure 5 shows the same concept map as Figure 4, but now used in the context of a real problem solution. In this problem, students were given a feed rate to a boiler in moles/time, a cross sectional area for the feed, inlet temperatures and pressures and the fact that it was liquid water being fed. The outlet was at a higher temperature and lower pressure, causing the formation of a vapor after the valve (the piece of equipment in the process). The final velocity was also specified while the students were asked to find the diameter of the exiting pipe. This is a classical steam table problem in chemical engineering with a liquid entering and vapor leaving.

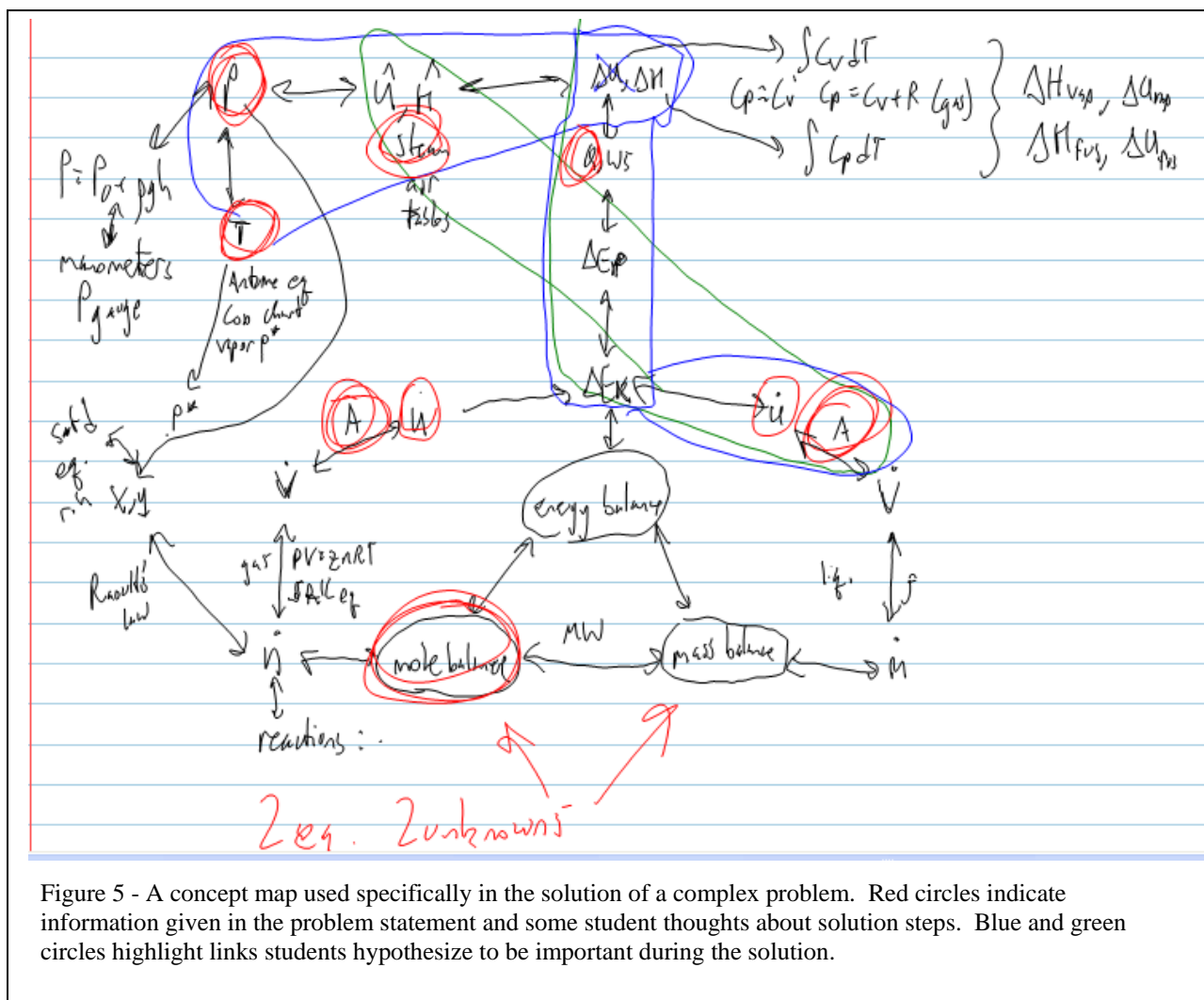


Figure 5 - A concept map used specifically in the solution of a complex problem. Red circles indicate information given in the problem statement and some student thoughts about solution steps. Blue and green circles highlight links students hypothesize to be important during the solution.

The first step in using the concept map was to circle all pieces of information from the problem statement and these circles appeared in red, as shown in Figure 5. With that done, students thought the problem solution could lead to 2 equations with 2 unknowns so a note was made of that comment (2eq. 2 unknowns). Overwhelmingly, students thought mole balances would be the route to go based on their earlier experiences with problems already shown in this work that used the ideal gas law for an pipe diameter changing problem.

Students confident in their brainstorming of approaches to the problem that there would be an energy balance through the first law of thermodynamics represented in the central vertical list of ideas, including the fact that  $Q$  would be zero for an adiabatic system (circled in red). Two students thought that one could use the fact that steam/water vapor was involved to directly link velocity of the liquid and the cross sectional area through specific volume ( $\hat{V}$  and not listed on the diagram) through the steam tables, which ended up shortcutting the solution steps by about 5 or 6 manipulations. The discussion about steps and process was open to all students and there was much debate about the variables and how one could use them to get to the end point of area ( $A$ ) and the diameter (not shown) for the gas in the middle part of the diagram. The author can comment that this was the first time a problem this complex was solved through presentation of a concept map in the class in addition to the problem statement where students drove the discussion. There was a lot of interplay among students as they discussed with each other what links led where and why some were not viable. This experiment of applying a concept map in a real time solution of a complex problem seemed to be a success as students brought copies of their maps to other classes and were annotating them and using them as starting points for exploring problem solutions throughout the rest of the semester.

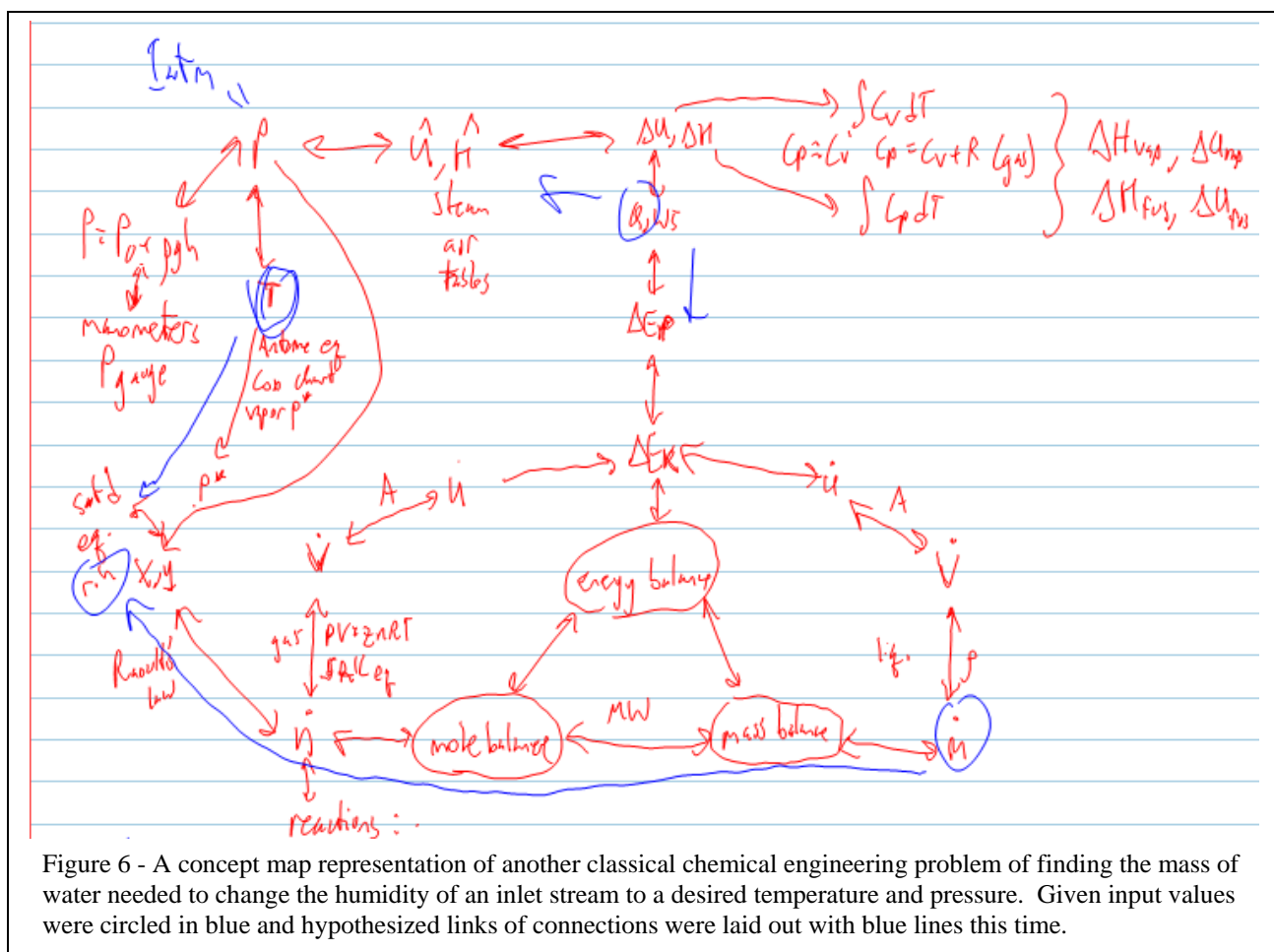


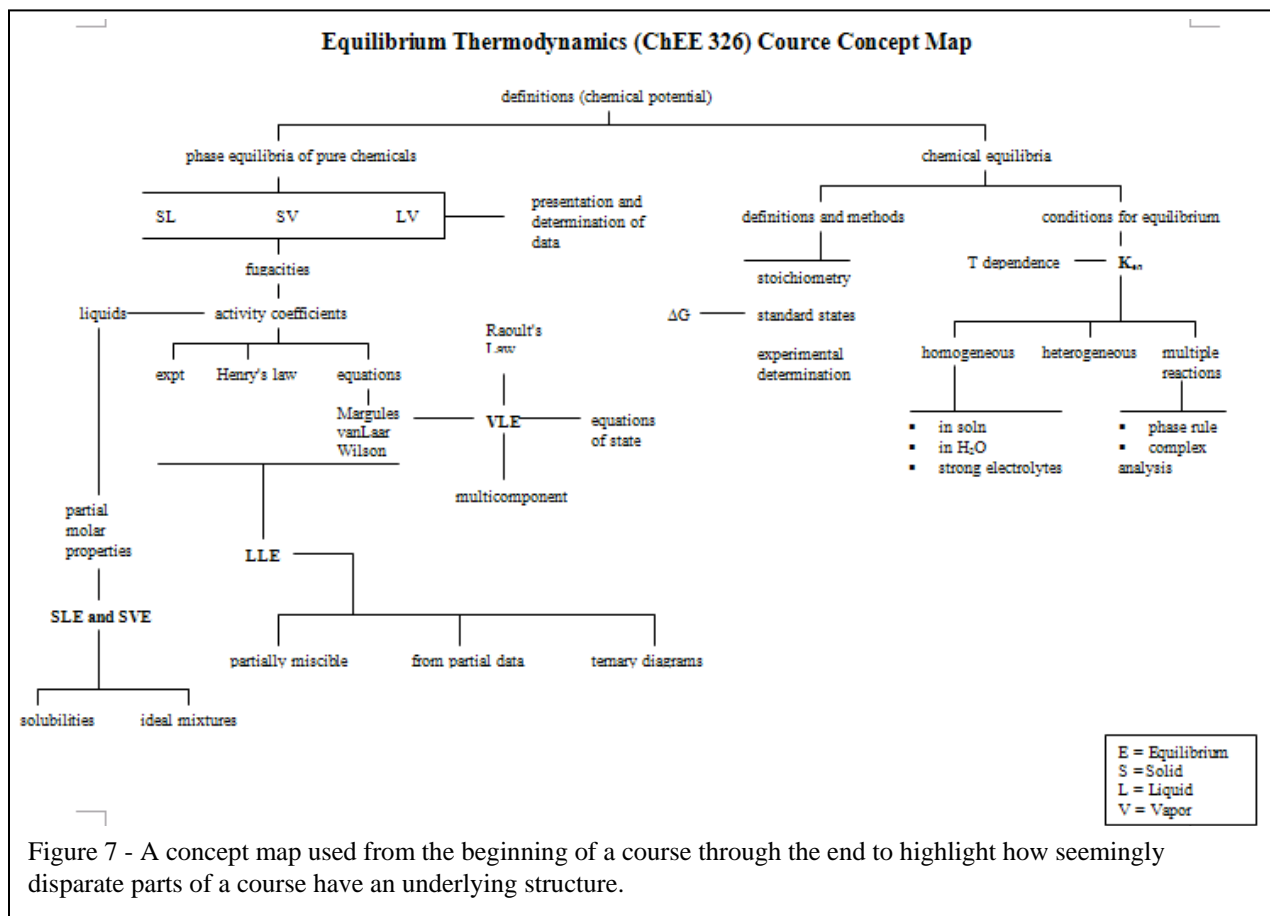
Figure 6 above shows a concept map that is related to Figure 3 in that this is another problem involving Raoult's law around a piece of equipment. This time, students were told they had a



humidifier and the flowrate of air in mass per time was specified in addition to the temperature and relative humidity. They were told the process was adiabatic and that water at a certain temperature as a liquid was added to the gas stream. The end result was a stream that had a specified relative humidity. The students were asked to find the final temperature and the amount of water that needed to be added to reach the desired relative humidity.

Based on previous problems and concept maps, students quickly realized there was an energy balance involving the adiabatic system where  $Q$  was zero. This then led them to the idea that enthalpies could be used (not shown on the diagram due to the pace of the discussion). However, the major thread of the solution went from mass in the lower right back through mole balances, through Raoult's law in the lower left, through relative humidity as a definition and then up to pressure where it was assumed to be 1 atm due to the system being open to the atmosphere. Students again argued back and forth about including some links over others before they solved the problem based on the concept map.

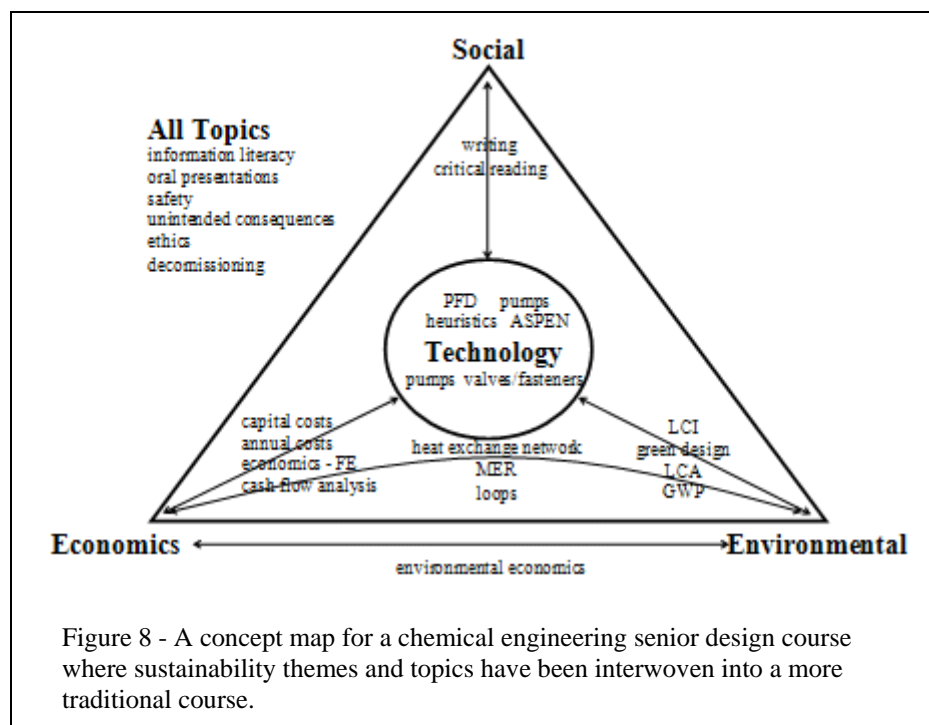
Leaving the sophomore class where the concept maps were used as problem solving tools and as prompts for review of material, concept maps can also be used to enable global learners, those who assimilate information in totality instead of sequentially, to get an idea of the structure of material and where new pieces will fit in as they are learned. Figure 7 shows a concept map handed out and then used during a junior equilibrium thermodynamics course.



In many chemical engineering thermodynamics courses, only the material in the upper left of the diagram is covered, particularly how to handle non-ideal vapor liquid equilibrium (VLE). In the course for this map, connections are made to liquid-liquid equilibrium (LLE) and solid-liquid equilibrium (SLE), in addition to solid-vapor equilibrium (SVE). The right hand side of the diagram shows that the very fundamental starting point of the class with definitions of equilibrium at the top of the diagram is the primary link to an entire second branch of reaction equilibria on the right side of the diagram. And within each topical area, there are details and subtopics that allow for greater investigation of different physical phenomena. The concept map in Figure 7 was used as a review tool before each exam in conjunction with the course objectives listed on the syllabus. The map was presented to students and students were asked to circle the parts of the diagram where homework had already been evaluated and returned, indicating to students what material was fair for coverage on the upcoming exams.

Prior to the creation of the concept map shown in the above figure, the instructor had experienced equilibrium thermodynamics as a series of disconnected modules with no common theme as discussed earlier. However, after creation of the visual map, they were able to conceptualize larger and more complex projects that would probe student understanding of the details in each area while sharing with them the power of the theories underlying the concepts.

Figure 8 shows a concept map used in the chemical engineering senior design course. Again, this concept map is furnished on the first day of class and then students are referred back to it as the co-instructors move back and forth among the different topics.



Sustainability, the ability to meet current needs without compromising the needs of future generations, has been included into a traditional chemical engineering senior design course in this case<sup>33</sup>. In the typical senior course, it is common to cover process flow diagrams (PFD), pieces of equipment, a simulation tool like ASPEN for chemical processes, rules of thumb for design,

economics, and energy and material recycle strategies. A traditional course will also include oral presentations, writing exercises, and some elements of dynamics. Sustainability topics that have been included are life cycle inventory and life cycle assessment as tools of evaluating sustainability (LCI and LCA), global warming potentials (GWP), safety, unintended consequences of technologies and processes, and decommissioning of facilities and rehabilitation of industrial brownfields. Throughout the course, information literacy has been introduced as a way of using popular and peer reviewed media to organize decisions around quantifiably sustainable processes.

This concept map was created in the third year of the course's offering as an integrated one with sustainability. It is interesting because students during the first two years had often commented on their anonymous teaching evaluations that they did not see why the topics were even in the same course. Also, students had pointed out that the sequence of material was random to their eyes. Those comments were valid in that the instructors rearranged the material around travel schedules. However, after the creation and introduction of the concept map, students no longer questioned the ordering or connections among the material. They could see how one could move between the environment and economics through one connection of environmental economic theory and decision making, or one could consider making process modifications through minimum energy need analyses or by creating material recycle loops.

In this paper, we've shown how concept maps have been used in different ways. First, like some of the works in the introduction, concept maps have been used as review and summary tools.

Students were provided with a map or ones were generated in course discussions using objectives listed in the syllabi. Similarly, the concept maps in Figures 4, 7, and 8 show how connections among material can be provided to students as a guide that helps both global and visual learners. On the other hand, this work is the first one that explores the use of concept maps during problem solving as a way of exploring how information can be transformed and aggregated to lead towards the end goal of a problem solution. This use was highlighted in Figures 3, 5, and 6.

Two evaluation tools will be examined in this work to examine student use of concept maps and successful outcomes. One evaluation tool will quantifiably examine whether student access to posted lecture materials was more frequent on days when concept maps were archived. Another assessment will involve student self-reports of their use or usefulness of the concept map approach.

#### Quantitative Access of Archived Concept Maps:

The first analysis of student use involves combining data from the D2L course management software used in the sophomore course with the content of each lecture's posted content. The D2L tool allows the instructor to monitor who accessed files and on which dates throughout the semester. A review of all OneNote lecture files showed that a concept map was first included on 9-29-08 and included the first five chapters of material. On 10-10-08, another concept map with more layers of connections was presented in the context of solving one problem solution. On 11-26-08, 12-1-08, and 12-3-08, larger concept maps, including almost all content from the course, were used in solving problems.

One would expect that the dates with those lectures would be more heavily accessed than others if students were responding to the introduction and use of concept maps. Figure 9 shows that student access to materials did not track with the dates when concept maps were included in the

archived material. Another work shows other trends in student use that more strongly correlated with access to the online materials<sup>35</sup>. These correlations include scheduling proximity to exams and the difficulty of the material. It is possible that future work could post concept map materials separately so better control over measuring what the students were specifically accessing would be possible. As the data stands, there may be multiple elements of a given lecture that led to the downloading of those materials over other lectures.

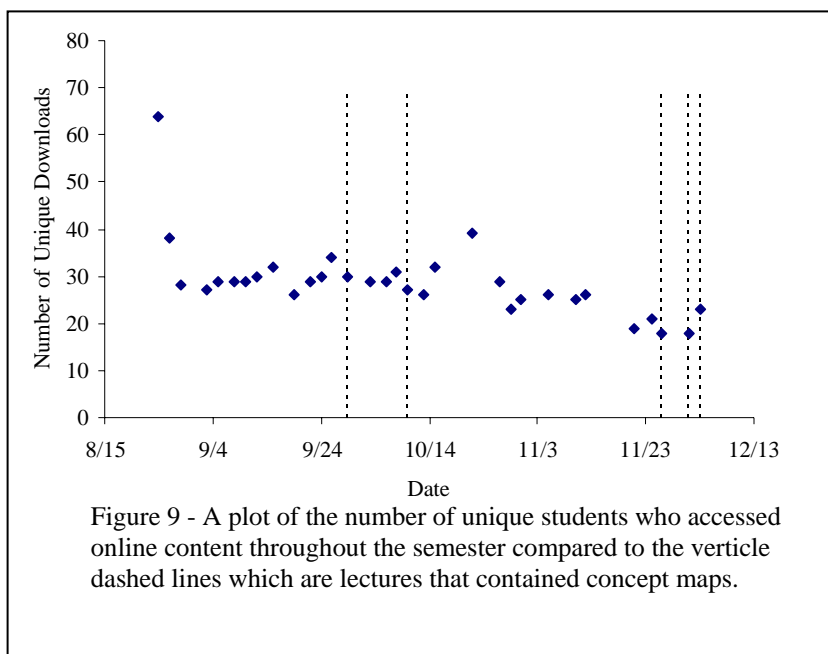


Figure 9 - A plot of the number of unique students who accessed online content throughout the semester compared to the vertical dashed lines which are lectures that contained concept maps.

### Anecdotal Information about Student Use and Views of Concept Maps:

In addition to the attempt to quantify student use of concept maps compared to their posting in lecture notes, student anecdotal stories also provide some insight. One student in the sophomore course stated that the concept maps enabled him to see connections he normally would not have and he went on to ask for help in constructing a concept map for the organic chemistry course he was enrolled in. He was then provided with a sample organic chemistry concept map<sup>1</sup> encountered in the literature during the writing of this paper. He commented that the reactions were now falling into patterns for him as opposed to being unlinked.

Another student, prior to the generation of the final sets of concept maps in the sophomore course, filled in and connected the details of new material to the existing structure from lecture. He commented that the exercise enabled him to solve the more complex problems with regularity. In the end, he credited his success in the course to using the concept map on every problem.

A large fraction of the class had representations of the concept maps in their study materials allowed during the exams in the sophomore course, choosing that content over other information they could have chosen for the limited space available. While a formal count of this was not done, approximately half or more of the class selected concept maps as material they used during the exams.

The sophomore classroom environment involves many active learning techniques. These techniques often involve posing a question to students and then encouraging them to work on solutions either individually or in small teams. The faculty member circulates and answers questions while also prodding students who are not making progress. Many students brought concept maps with them to class after they were introduced and used them during these activities to search out connections that would enable them to solve problems.

In a prior year when concept maps were used in the sophomore class, one student went on to form a small group that organized their own concept map for another core course known locally as being extremely challenging with a high attrition rate. The student, who was a solid B student, and his team went on to receive the highest scores on the exams through their preparation of concept maps. They felt it was this outside connection drawing that enabled them to move to the level that was being tested in that subsequent course.

Similar to the sophomore class, juniors and seniors often referred to the concept maps when discussing which concepts were eligible for coverage on upcoming exams. These discussions would start with a list of course objectives and what was fair game and students naturally moved the discussion on their own to the concept map, often then asking questions about how the material was fundamentally linked together.

Future work should be done to more quantifiably measure how learning styles and the use of concept maps helps or hinders different subsections of student populations succeed in engineering problem solving. This would involve the students taking a diagnostic test that identified their learning style while then controlling access to, or training in how to use, concept maps. It would also be an interesting study to quantify changes in student attrition rates over

time to see if concept maps may enable those students who normally would have left engineering to succeed.

## Conclusion

This work discussed how concept maps have been used in many different disciplines, often with a subsequent raising of student performance as assessed through exams or other measures. An exploration of the use of concept maps showed that they had not previously been used during the problem solving process in order to reveal connectivity of topics to students. This work showed both traditional uses of concept maps and this new idea of using them to foster problem solving skills in the context of core chemical engineering courses. While student increases in performance were not measured in this work, the groundwork has now been laid for evaluating how integration of concept maps into curricula improves student performance in problem solving and problem syntheses tasks while possibly impacting student retention rates.

## References

- (1) Sket, B., Glazar, S. A. *Acta Chim. Slov.* **2005**, *52*, 471.
- (2) Henderson, C., Yerushalmi, E.; Kuo, V. H.; Heller, K.; Heller, P. *Phys. Rev. Spec. Top. Phys. Educ. Res.* **2007**, *3*, 020110.
- (3) Ausubel, D. P. *Educational Psychology: A Cognitive View*; Holt, Rinehart & Winston: New York, 1968.
- (4) Schau, C., Mattern, N. *The Amer. Stat.* **1997**, *51*, 171.
- (5) Nesbit, J. C., Adeosope, O. O. *Rev. Educ. Res.* **2006**, *76*, 413.
- (6) Novak, J. D. *Learning, creating, and using knowledge: Concept maps as facilitative tools in schools and corporations*; Lawrence Erlbaum and Associates: Mahwah, NJ, 1998.
- (7) Kinchin, I. M., Cabot, L. B. *Eur. J. Dent. Educ.* **2007**, *11*, 194.
- (8) Kaya, O. N. *Res. Sci. Educ.* **2008**, *38*, 91.
- (9) Moni, R. W., Beswick, E.; Moni, K. B. *Adv. Physiol. Educ.* **2005**, *29*, 197.
- (10) Hay, D. B., Kehoe, C.; Miguel, M. E.; Hatzipanagos, S.; Kinchin, I. M.; Keevil, S. F.; Lygo-Baker, S. *Brit. J. Educ. Tech.* **2008**, *39*, 1037.
- (11) Diwakar, V., Ertmer, P. A.; Nour, A. Y. M. *J. Vet. Med. Educ.* **2007**, *34*, 652.
- (12) Moni, R. W., Moni, K. B. *Adv. Physiol. Educ.* **2007**, *32*, 47.
- (13) Kinchin, I., Hay, D. *J. Adv. Nursing* **2005**, *51*, 182.
- (14) Kao, G. Y.-M., Ling, S. S. J.; Sun, C.-T. *Comp. & Educ.* **2008**, *51*, 1718.
- (15) Tseng, S.-S., Sue, P.-C.; Su, M.-M.; Weng, J.-F.; Tsai, W.-N. *Comp. & Educ.* **2007**, *49*, 691.
- (16) Gurlitt, J., Renkl, A. *J. Comp. Assisted Learning* **2008**, *24*, 407.
- (17) Kostovich, C. T., Poradzisz, M.; Wood, K.; O'Brien, K. L. *J. Nursing Educ.* **2007**, *46*, 225.
- (18) Felder, R. M., Silverman, L. K. *Engr. Educ.* **1988**, *78*, 674.
- (19) Felder, R. M., Spurlin, J. *Int. J. Engr. Educ.* **2005**, *21*, 103.
- (20) Felder, R. M., Brent, R. *J. Engr. Educ.* **2005**, *94*, 57.
- (21) Litzinger, T. A., Lee, S. H.; Wise, J. C.; Felder, R. M. *J. Engr. Educ.* **2007**, *96*, 309.
- (22) Hilbert, T. S., Renkl, A. *Instr. Sci.* **2008**, *36*, 53.
- (23) Blowers, P. "Use of Web-Based Examples in Engineering Courses"; American Society for Engineering Education Annual Conference and Exposition, 2002, Albuquerque, NM.
- (24) Blowers, P. "A Course of Freshmen Survival Skills"; American Society for Engineering Education Annual Conference and Exposition, 2002, Albuquerque, NM.
- (25) Blowers, P. "Course Syllabus Construction: A Stitch in Time Saves Nine"; American Society for Engineering Education Annual Conference and Exposition, 2002, Albuquerque, NM.

- (26) Williams, B., Blowers, P.; Goldberg, J. "Integrating Information Literacy Skills into Engineering Courses to Produce Lifelong Learners"; American Society for Engineering Education Annual Conference & Exposition,, 2004, Salt Lake City, UT.
- (27) Williams, B., Blowers, P. "Deconstruction of an engineering syllabus for information literacy"; American Society for Engineering Education Annual Conference & Exposition, 2003, Memphis, TN.
- (28) Ogden, K., Blowers, P. "Integration of Sustainability and Industrial Mentors into Capstone Design"; ICEER 2007 Meeting, 2007, Queensland, Australia.
- (29) Blowers, P. *CSE Archive of Peer-Reviewed Sustainability Instructional Modules 2008*.
- (30) Blowers, P. "Breaking the Curve - Why a Straight-Scale is Appropriate in Engineering Courses"; American Society for Engineering Education Annual Conference and Exposition, 2002, Albuquerque, NM.
- (31) Blowers, P., Williams, B. "A Quantitative Investigation into whether the Publication of Engineering Pedagogical Material is an Indicator of Value in 'Rankings' when Assessing Instruction"; American Society for Engineering Education Annual Conference & Exposition, 2003, Memphis, TN.
- (32) Blowers, P. *College Teaching 2003, Summer*, 111.
- (33) Ogden, K., Blowers, P. "Integration of Sustainability and Industrial Mentors into Capstone Design"; ICEER, 2007, Queensland, Australia.
- (34) Felder, R. M., Rousseau, R. W. *Elementary Principles of Chemical Processes*; John Wiley & Sons: Hoboken, NJ, 2005.
- (35) Blowers, P. "Application of Multimodal Software Tools to Teach Problem Solving Skills"; ASEE National Conference, 2009 (submitted), Austin, TX.

### **Biographical Sketch**

Paul Blowers received his PhD from UIUC in 1999 and has been a professor in chemical and environmental engineering at the University of Arizona since that time. He has been recognized as a top educator at the departmental and regional levels and in the past year was recognized as the best faculty academic advisor at his institution. He then went on to be selected as one of the top four faculty advisors in the U.S. by the National Association of Academic Advisors.

## **A Framework for Developing Courses on Engineering and Technology for Non-Engineers**

**Vince Bertsch**, Santa Rosa Junior College  
Engineering Department Chair

**John Krupczak**, Hope College  
Professor of Engineering

**Kate Disney**, Mission College  
Engineering Faculty

**Elsa Garmire**, Dartmouth College  
Professor of Engineering

**Tim Simpson**, University of Pennsylvania  
Professor of Engineering

### **Abstract**

Americans need a better understanding of the wide variety of technology used everyday. The need for technological literacy is great for both individuals and the nation in general. Creating a population with a more empowered relationship with technology will require a significant and extensive initiative in undergraduate education. Curricula and course materials that are easily adoptable in diverse and varied institutional environments are vital in this effort. The National Academy of Engineering in two reports: *Technically Speaking: Why All Americans Need to Know More about Technology* (2002), and *Tech Tally: Approaches to Assessing Technological Literacy* (2006), outline the characteristics of a technologically literate citizen. The International Technology Education Association (ITEA) and the American Association for the Advancement of Science (AAAS) have also developed standards for technological literacy. The NSF supported a working group lead by the American Society for Engineering Education (ASEE) Technological Literacy Constituent Committee to develop standardized and readily adoptable undergraduate courses on this topic. This group met on March 26-27, 2007 and developed four models to serve as standardized courses on technology. A framework was established for specific course outlines consistent with the content areas established in *Tech Tally* of: technology and society, design, products and systems, and technology core concepts and the ITEA technology topic areas. To make it possible to accommodate the diverse requirements of curriculum committees on varied campuses, the framework offers flexibility to faculty in planning courses within each proposed model while still accomplishing the goals of the standards. This framework will form the organizational infrastructure for creating a repository of course materials as well as an online community for course developers and instructors.



## Overview

Technology affects nearly every aspect of our lives, and informed citizens need an understanding of what technology is, how it works, how it is created, how it shapes society, and how society influences technological development. How well American citizens are prepared to make technological choices depends in large part on their level of technological literacy. Technological choices influence our health and economic well-being, the types of jobs and recreation available, even our means of entertainment. At a recent NSF Workshop at the National Academy of Engineering (NAE) participants drafted a set of standard course models for teaching technological literacy courses [1,2]. As part of that workshop, a framework for creating courses on technological literacy was developed. This framework can also provide a useful context for discussing standard models for technological literacy courses. A common framework is not only critical for developing effective technological literacy courses but is also a pre-requisite for developing standard course models.

The proposed framework will help faculty develop proficiency in adapting existing best-practice course materials and using standards for defining technological literacy when planning their own courses.

## What Is Technological Literacy?

In *Tech Tally* [3], the NAE described technological literacy as “an understanding of technology at a level that enables effective functioning in a modern technological society”. This is consistent with E.D. Hirsh’s general definition of “literacy” as “information that is taken for granted in public discourse” [4]. *Tech Tally* followed a 2002 report by the NAE entitled, *Technically Speaking: Why All Americans Need to Know More about Technology*. This report explained the importance of being literate about technology in the 21<sup>st</sup> century [5]. Both NAE reports emphasize that technology, in a broad sense, is any modification of the natural world made to fulfill human needs and wants. Technology includes not only tangible products, but also the knowledge and processes necessary to create and operate those technological products. The supporting infrastructure used for the design, manufacture, operation, and repair of technological devices and systems is also considered part of technology, in the widest sense.

Other efforts have been underway for over a decade to develop standards and guidelines to define what K-12 students need to know and be able to do in regard to technology. In 1993, the American Association for the Advancement of Science (AAAS) published, *Project 2061: Benchmarks for Science Literacy* [6] and in 1996 the *National Science Education Standards* were published by the National Academies Press [7], both of these contained sections addressing technology. In 2000 the International Technology Education Association (ITEA) released *Standards for Technological Literacy: Content for the Study of Technology* [8] with the goal of encouraging educational curricula and programs that would provide technological literacy to K-12 students.

In the *Tech Tally* report, the NAE identified three major components, also called cognitive dimensions, related to technological literacy. These are *knowledge*, *capabilities*, and *critical thinking and decision-making*. As defined in this report, “The ‘*knowledge dimension*’ of

technological literacy includes both factual knowledge and conceptual understanding. The ‘*capabilities dimension*’ describe how well a person can use technology (defined in its broadest sense) and carry out a technological design process to solve a problem. The final dimension – the ‘*critical thinking and decision-making*’ dimension – has to do with the person’s approach to technological issues” [3]. This dimension enables individuals to ask informed questions about risks and benefits when introduced to a new technology, and to participate in discussions and debates about the potential uses of that technology. Four content areas were also defined. These are: (1) technology and society, (2) design, (3) products and systems, and (4) characteristics, concepts, and connections. In addition, an assessment matrix was created that combined the four content areas (the rows of the matrix) with the three cognitive dimensions (the columns of the matrix), and it is this matrix that lead to the development of the proposed framework reported here.

At the same time, the International Technology Education Association (ITEA) also developed a set of standards (ITEA 2000) for technological literacy, which was published in a report entitled, *Standards for Technological Literacy: Content for the Study of Technology* [8]. The ITEA 2000 Standards are divided into five main categories that are further sub-divided into 20 specific standards. The five main categories are:

1. Understanding the Nature of Technology
2. Understanding of Technology and Society
3. Understanding of Design
4. Abilities for a Technological World
5. Understanding of the Designed World.

The ITEA 2000 standards were intended to address K-12 students, however it was found that the detail of these standards was helpful in categorizing or classifying content areas that might appear in technological literacy courses for undergraduates as well. The curriculum framework integrates these disparate attempts to define technological literacy and addresses the overlap between the NAE and ITEA approaches.

### **Engineering and Technology Courses for Non-Engineers.**

Some engineering programs have embraced the need to increase the awareness and understanding of engineering as a career by initiating a number of programs aimed at the K-12 audience. An example is the American Society for Engineering Education’s (ASEE) publication, *Engineering Go For It*, [9] and a website [10] for K-12 students and teachers. The major engineering societies have outreach activities for K-12 [11-14]. At the same time, the ITEA is developing program and assessment standards, and curriculum materials for K-12 education [15]. Engineering departments offering courses on technological topics for non-engineering students are beginning to appear [16].

The recent history of efforts to address the technological literacy of undergraduates can be considered to start in 1982 when the Alfred P. Sloan Foundation established the New Liberal Arts Program (NLA). The goal was to improve undergraduate education in the areas of

technology and quantitative reasoning [17-19]. The Sloan Foundation sponsored development of courses on technological topics for non-science majors. The NLA Program broke new ground in establishing technology as the intellectual peer of science at the college level; however, the experience of the NLA highlighted the difficulty in transfer of courses beyond the founding instructor and campus, and maintaining course offerings after expiration of external funding [20].

After the NLA, some engineering educators have worked on aspects of the broad understanding of technology by undergraduates [21-23]. While the total number of courses reported has been limited [24-53,61-63], results have been significant. Several courses have been successful in attracting substantial enrollments of non-engineering students and existing as long-term offerings [25-29,35-41,44-46,52,53]. Some specific examples include *Technology 21*, created at the University of Denver [52]. In this course non-engineers study a technological controversy and develop a recommendation for public policy. The course has been taught by the Electrical Engineering Department for more than 14 years and nearly all departmental faculty have served as course instructor. The Converging Technologies Initiative at Union College created nearly 30 new or modified courses since 2002 on interdisciplinary technological topics such as pervasive computing and nanotechnology [25,35]. At California State University Northridge, the Manufacturing Systems Engineering Department has taught Computer-Aided Design to campus-wide constituency for a decade [53]. Dartmouth College has had a requirement since 1992 that every student take a course in Technology and/or Applied Science. The majority of these courses are taught by engineering faculty, and some have enrolled as many as 150 students [54].

simultaneously with these efforts by engineering departments to reach non-engineers, some college and university physics departments have altered their service course offerings for non-majors to emphasize technological topics. Examples include Dudley and Bold's, "Top-Down Physics" [55], and Watson's "The Science Concepts behind High Technology" and "Silicon, Circuits, and the Digital Revolution" courses [56]. Bloomfield has developed a course and book entitled *How Things Work: The Physics of Everyday Life* [57,58]. This approach of technologically-themed and application-oriented science courses for non-science majors incorporates perspectives that are closer to engineering than typical physical science courses. These efforts at presenting the learning of physics through the understanding of modern technology are a marked change from earlier classic works such as *Physics for the Inquiring Mind* [59] and *Physics for Poets* [60]. These books avoided technological applications and emphasized philosophical questions and natural phenomena.

These developments show that there is both demand and interest among the non-engineering undergraduate population for courses on technological issues. It also establishes that engineering faculty can develop and teach courses on technological topics to non-engineers. The successful courses taught by engineers span a wide range of institution type and student demographics. They represent campus environments that includes large state universities [45-48,51], private colleges [29,37], technically institutions [49,50], selective schools [26,27,40,43], comprehensive universities [28,44], schools serving working adults [16], and two year colleges [63,64]. The background of the instructors include the major engineering disciplines such as chemical [48], civil [26-28,44], electrical [34,36,40], materials [45,46,61] and mechanical engineering [24,29,31,37]. A feature of nearly all successful technology courses is the need to satisfy some

component of the college or university general education graduation requirement and to be adapted to instructor interests or other aspects of local institutional conditions [65,66].

To determine the research issues regarding the broad understanding of technology by all undergraduates, a workshop on the technological literacy of undergraduates was sponsored by the NSF and held at the NAE in April 2005. There were 42 participants included faculty who had implemented courses on technological literacy for undergraduates as well as representatives from other engineering and non-engineering disciplines. An important outcome from the workshop was the recommendation that: “There is a need for a best practice collection of easily adopted materials.” [67,68].

Most of the existing technological literacy courses were established before the NAE and the ITEA developed technological literacy standards for this topic. Individual instructors determined course syllabi based on their own expertise and inclinations. As part of the 2005 NSF/NAE Workshop, participants found that elements of the NAE and ITEA standards had been incorporated into most of the existing courses; however, no single existing course included all of the standards due to their breadth. With this came the recognition that no one standard course model could be developed for a single course on technological literacy. Rather, four standard course models were established and slated for development as part of the follow-on NSF/NAE Technological Literacy for Undergraduates Workshop, which was held in March 2007 [1,2]. The four standard course models are: (1) Technology Survey Course, (2) Technology Focus Course, (3) Technology Design Course, and (4) Technology Critique, Assess, Reflect, or Connect Course. The framework described here was created to serve as a guideline for developing these standard course models but also as a means to evaluating existing technological literacy courses.

### **Description of the Proposed Framework**

The framework was developed by a team at the 2007 NSF/NAE Workshop on Technological Literacy of Undergraduates [1,2]. The framework takes the form of a 2D matrix that maps content areas – called *cross-cutting concepts* – to different *technology topic* areas, as shown in Figure 1. The technology topic areas – the columns in the matrix – are derived from the “Designed World” categories defined by the ITEA 2000 Standards [8] and include an additional “Other” category for areas that the faculty felt were missing from ITEA’s Designed World (e.g., space technology, military technology, materials, entertainment systems).

The rows of the matrix in Figure 1 are cross-cutting concepts group, which are based on the four content areas defined in *Tech Tally* [3]: (i) Technology & Society, (ii) Design, (iii) Products & Systems, and (iv) Characteristics, Core Concepts, & Connections.

Each cell in the matrix can then be populated with one of four values to indicate the depth of coverage of that cross-cutting concept in each technology topic area:

1. K → Knowledge, i.e., the course will provide knowledge about this cross-cutting concept within the context of this technology topic area
2. C → Capabilities, i.e., the course will develop capabilities in this cross-cutting concept that can be applied within the context of this technology topic area

3. D → Decision-making, i.e., the course will enable decision-making within the context of this cross-cutting with regards to this technology topic area
4. Blank – Indicates that this cross-cutting concept is not covered to any extent within this technology topic area

These three areas (K, C, D) are based on the three Cognitive Dimensions of Technology Literacy that are defined in *Technically Speaking* [5] and *Tech Tally* [3] where “Critical Thinking & Decision-making” has been simplified to “Decision-making”. The levels (K, C, D) are arranged in terms of their degree of understanding, and it is recognized that higher levels of coverage (e.g., Decision-making) also include the lower levels of understanding as well (i.e., Knowledge and Capabilities). This is consistent with the Bloom’s taxonomy where higher levels of the taxonomy include the ability to demonstrate the lower-level skills as well [69,70].

	Science and Technology							
	Applications							Theory
	Medical	Agriculture & Biotechnologies	Energy & Power	Information & Communication	Transportation	Manufacturing	Construction materials, entertainment, etc.)	Natural World
Mathematical Underpinnings								
Scientific Facts and Principles								
Scientific Method								
Environmental & Societal Interdependence								
History/Evolution of Science & Technology								
Disciplines of STEM								
Ethics								
Design Process								
Risk/Safety								
Tradeoffs/Cost-Benefit Analysis								
Intended/Unintended Consequences								
Satisfying Human Wants & Needs								
Energy, Materials, & Information Flow								
Interdependence/Interactions								
Dynamic/Static Systems								
Systems Perspective								
Control & Feedback								
Complexity								

**Figure 1. Proposed Framework: The Tech Lit Course Evaluation Matrix**

Using this matrix representation, four types of technology literacy courses are defined. These four types constitute the standard course models that were created as part of the NSF/NAE Technological Literacy Workshop [1,2]:

- (1) Technology Survey Courses
- (2) Technology Focus Courses
- (3) Technology Design Courses
- (4) Technology Critique, Assess, Reflect, or Connect (CARC) Courses

These are shown in Figure 2. As shown in the figure, it is expected that Survey Courses will span the majority of the matrix with K, C, and D values (see Figure 2a). Due to time constraints and limited course duration, it is not anticipated that any Survey course will completely fill the entire matrix, but it would also be expected that no row will be entirely blank – if it is, then it will not likely qualify as a true Survey course. Meanwhile, a column could be blank if a technology topic area is not covered due to time limits, but a good Survey will likely cover a majority of these technology areas.

Technological Literacy Focus Courses will go into great depth within one or more technology topic areas (see Figure 2b) with a higher fraction of C and D values in that column(s) when compared to a Survey Course.

Technological Literacy Design Courses and Critique, Assess, Reflect, or Connect (CARC) Courses will cover these respective rows in the matrix for one or more of the technology topic areas as shown in Figures 2c and 2d, respectively. It is expected that these courses will also have a higher percentage of C and D values in the corresponding rows – specifically for the detailed cross-cutting concepts within each group – compared to a Survey Course.

Figure 3 shows two examples of the matrix for two courses that were selected from among the 22 existing technology literacy courses surveyed during the 2007 NAE/NSF Workshop [1,2]. In this survey, instructors were only asked to what extent their course covered the cross-cutting concepts at the group level and which technology topic areas were covered, but not to what extent each cross-cutting concept was covered in each technology topic area. It can therefore only be determined to an approximate extent what a Technology Survey Course (see Figure 3a) and Technology Focus Course (see Figure 3b) will actually look like; however, it provides reasonable proof-of-concept for this matrix representation.

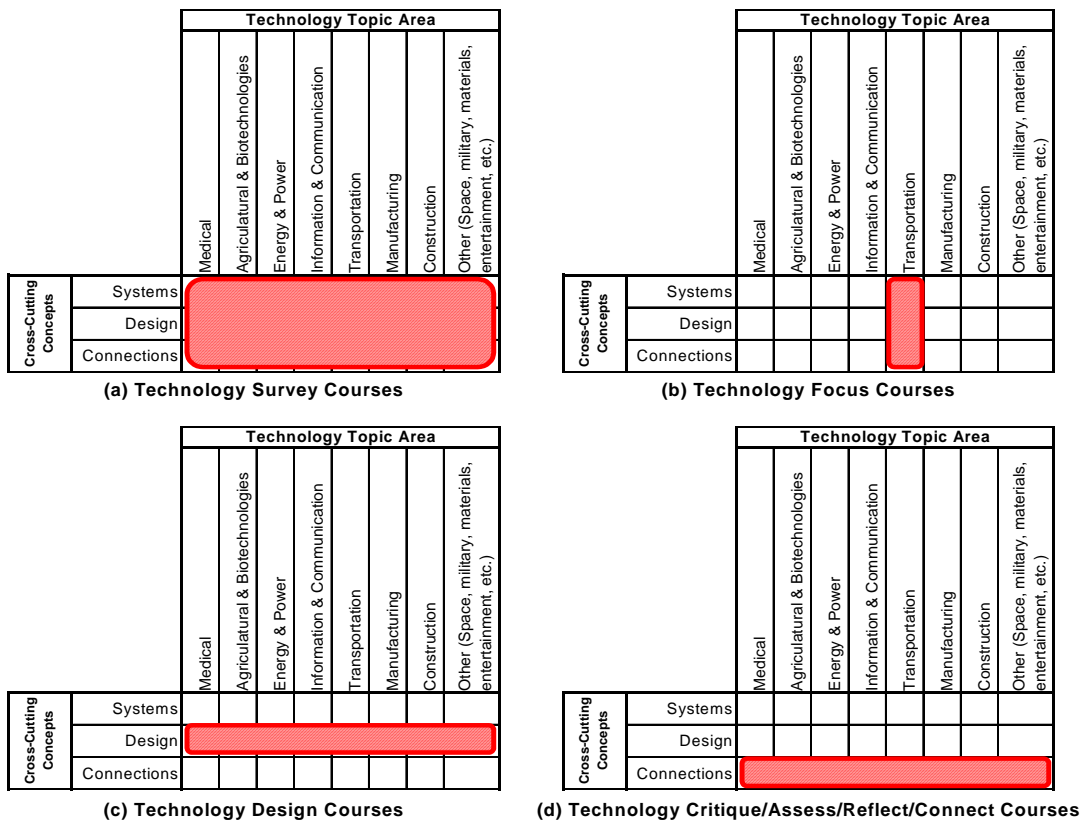


Figure 2. Using the Matrix to Define Four Types of Tech Lit Courses

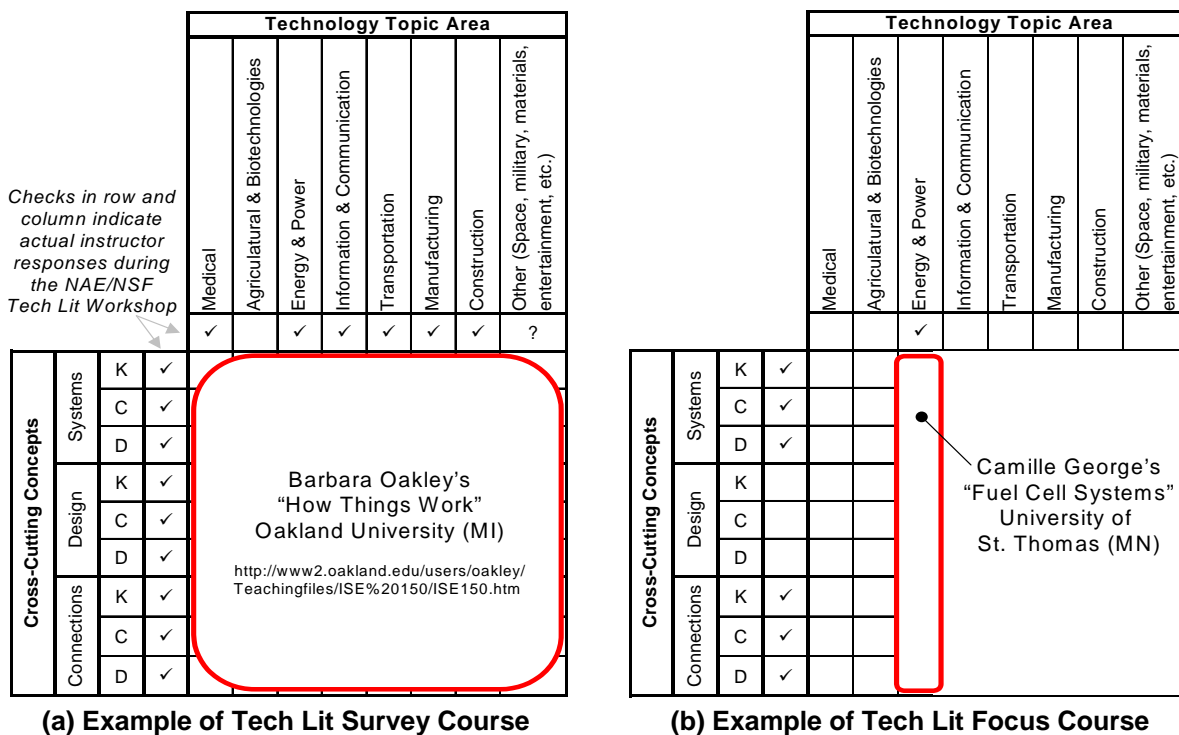


Figure 3. Instances of the Matrix based on 22 Tech Lit Courses at NAE/NSF Workshop

## Description of Current Work

The proposed framework for evaluating technology literacy courses was developed from a survey of technology-focused courses and their developers conducted before the NSF/NAE workshop. This survey asked instructors to compare their existing course to the standards prescribed in *Tech Tally* [4] and the *ITEA Standards for Technological Literacy* [8]. The survey only addressed the highest level of the standards and did not include any other aspects of the course such as pedagogy and assessment. The initial survey resulted in 22 courses [1,2]. Current work is broaden the database of courses considered.

The framework shown in Figure 1 will be used as an organizational infrastructure for a web-based repository of best-practice course materials. This online matrix will link to course materials from existing technological literacy courses and enable users to build technological literacy courses by selecting materials from cells, rows, or columns as needed. Contributing educators will be able to populate the matrix by either submitting modules or full course materials. Posting modules or courses will automatically populate one common matrix familiar to all instructors. Users will be able to view individual course matrices or search along one dimension (row or column) of the common matrix. Each matrix cell will have a pull-down menu indicating cognitive level K, C, and D. Users will be able to select the needed depth and post material to, or take material from, any given depth and category. In addition to downloading modules, users will be able to create a complete course online.

The ultimate goal of this work is to fill all cells of this framework with publicly available materials. These materials will then be accessed and used by instructors to develop curriculum for new technological literacy courses. The goal is to streamline the course development process for faculty members at both two- and four-year institutions. Providing a wiki-like environment of best-practice materials open to the public with controlled editing access will help expand participation in this area.

## Acknowledgement

The work was supported by the National Science Foundation under award: DUE-0714137. Any opinions, findings, and conclusions or recommendations expressed in this material are those of the authors and do not necessarily reflect the views of the National Science Foundation.

## Bibliography

1. Technological Literacy of Undergraduates: Developing Standard Models, A Workshop at the National Academy of Engineering, March 27-28, 2007.  
[http://www.nsf.gov/events/event\\_summ.jsp?cntn\\_id=108527&org=NSF](http://www.nsf.gov/events/event_summ.jsp?cntn_id=108527&org=NSF)  
[http://www.nsf.gov/attachments/108527/public/Tech\\_Lit\\_Workshop\\_Background.pdf](http://www.nsf.gov/attachments/108527/public/Tech_Lit_Workshop_Background.pdf) (May 1, 2007).
2. Krupczak, J.J., D. Ollis, W. B. Carlson, K.Neeley, R. Pimmel, and G. Pearson, "The Technological Literacy of Undergraduates: Developing Standard Models," *Proceedings of the 37th ASEE/IEEE Frontiers in Education Conference*, (2007).



3. *Tech Tally: Approaches to Assessing Technological Literacy*, Elsa Garmire and Greg Pearson, editors, National Academies Press, (2002).
4. E. D. Hirsch and James S. Trefil, *Cultural Literacy: What Every American Needs to Know*, Random House, (1987).
5. *Technically speaking: Why all Americans need to know more about technology*, Greg Pearson and A. Thomas Young, editors, National Academies Press, (2002).
6. *Project 2061: Benchmarks for Science Literacy*, American Association for the Advancement of Science, Oxford University Press, (1993).
7. *National Science Education Standards* , National Research Council, National Academies Press, (1996).
8. International Technology Education Association. *Standards for Technological Literacy*, International Technology Education Association, Reston, VA (2000).  
<[http://www.iteaconnect.org/TAA/Publications/TAA\\_Publications.html](http://www.iteaconnect.org/TAA/Publications/TAA_Publications.html)> (May 1, 2007).
9. *Engineering Go For It: Your Guide to an Exciting Future*, American Society for Engineering Education, Washington, D.C. (2003).
10. The ASEE Engineering K12 Center, <http://www.engineeringk12.org/>, American Society for Engineering Education (May 1, 2007).
11. ASME Pre-College Education for the Future, American Society of Mechanical Engineers, <http://www.asme.org/education/precollege/> (May 1, 2007).
12. ASCE Kids and Careers, American Society of Civil Engineers, <http://www.asce.org/kids/> (May 1, 2007).
13. IEEE Pre-College Education, Institute of Electrical and Electronics Engineers, <http://www.ieee.org/organizations/eab/precollege/> (May 1, 2007).
14. Career Choices for Chemical Engineers, <http://www.aiche.org/careers/>, American Institute of Chemical Engineers (May 1, 2007).
15. *Advancing Excellence in Technological Literacy: Student Assessment, Professional Development, and Program Standards (AETL)*. International Technology Education Association, Reston, VA (2000).
16. Oakley, B., L. Smith, Y. Chang, "The Untapped Student Goldmine," *Proceedings of the 2007 American Society for Engineering Education Annual Conference* (2007). In press.
17. Goldberg, Samuel. 1990. The New Liberal Arts Program: A 1990 Report, Alfred P. Sloan Foundation, 630 Fifth Avenue, New York, NY 10011 (December 1990).
18. Trilling, L. New Liberal Arts Educational Materials, Council for the Understanding of Technology in Human Affairs, The Weaver: Information and Perspectives on Technological Literacy, 9(1)1994.
19. Steen, Lynn Arthur, "The New Liberal Arts Program: Alfred P. Sloan Foundation, 1980-1992." St. Olaf College, 1520 St. Olaf Avenue, Northfield, Minnesota. (1999) <<http://www.stolaf.edu/other/ql/nla.html> > (May 1, 2007).
20. Ames, O., A Program for Technological Literacy in the Liberal Arts, *Journal of College Science Teaching*, March/April. 286-288, (1994).

21. Byars, N.A., "Technology Literacy Classes: The State of the Art", *Journal of Engineering Education*, Jan, (1998), pp. 53-61. <<http://www.asee.org/publications/jee/PAPERS/display.cfm?pdf=536.pdf>> (May 1, 2007).
22. Hanford, Bethany, "Engineering for Everyone," American Society for Engineering Education, *PRISM*, December 2004. American Society for Engineering Education. <[http://www.prism-magazine.org/dec04/feature\\_engineering.cfm](http://www.prism-magazine.org/dec04/feature_engineering.cfm)> (May 1, 2007).
23. Krupczak, J.J "Reaching Out Across Campus: Engineers as Champions of Technological Literacy," *Liberal Education in the 21<sup>st</sup> Century*, Worcester Polytechnic Institute Series on Studies in Science, Technology, and Culture, H. Luegengbil, K. Neeley, and D. Ollis, editors, Peter Lang Publishers, New York, (2004).
24. Baish, J.W., and T.P. Rich, "Design as a Liberal Art," *Proceedings of the 2001 American Society for Engineering Education Annual Conference* (2001). American Society for Engineering Education. <[http://www.asee.org/acPapers/00208\\_2001.PDF](http://www.asee.org/acPapers/00208_2001.PDF)> (May 1, 2007).
25. Balmer, R.T., "Converging Technologies: The New Frontier in Engineering Education, *Proceedings of the 2002 American Society for Engineering Education Annual Conference* (2002). American Society for Engineering Education. <[http://www.asee.org/acPapers/2002-777\\_Final.pdf](http://www.asee.org/acPapers/2002-777_Final.pdf)> (May 1, 2007).
26. Billington D., *The Innovators: The Engineering Pioneers Who Made America Modern*," Wiley (1996).
27. Billington D.P and D. P. Billington Jr., *Power, Speed, and Form: Engineers and the Making of the Twentieth Century*, Princeton University Press (2006).
28. Daniels, S., M. Collura, B. Aliane, J. Nocito-Gobel, "Project-Based Introduction to Engineering – Course Assessment, *Proceedings of the 2004 American Society for Engineering Education Annual Conference* (2004). American Society for Engineering Education. <[http://www.asee.org/acPapers/2004-1969\\_Final.pdf](http://www.asee.org/acPapers/2004-1969_Final.pdf)> (May 1, 2007).
29. DeGoede, K., "Synthesizing Liberal Arts Physics," *Proceedings of the 2004 American Society for Engineering Education Annual Conference* (2004). American Society for Engineering Education. <[http://www.asee.org/acPapers/2004-1542\\_Final.pdf](http://www.asee.org/acPapers/2004-1542_Final.pdf)> (May 1, 2007).
30. Drake, R. L., "Society and Technology for Non-Engineering Majors, "*Proceedings of the 1996 American Society for Engineering Education Annual Conference* (1996) American Society for Engineering Education. <<http://www.asee.org/acPapers/code/getPaper.cfm?paperID=303&pdf=01545.pdf>> (May 1, 2007).
31. George, C., "Fuel Cells and Discovery-Oriented Teaching," *Proceedings of the 2004 American Society for Engineering Education Annual Conference* (2004). American Society for Engineering Education. <[http://www.asee.org/acPapers/2004-1861\\_Final.pdf](http://www.asee.org/acPapers/2004-1861_Final.pdf)> (May 1, 2007).
32. George, C., E. Amel, K. Mueller, "A Solar-Powered Decorative Water Fountain Hands-On Build To Expose Engineering Concepts To Non-Majors," *Proceedings of the 2006 American Society for Engineering Education Annual Conference* (2006). American Society for Engineering Education. <<http://www.asee.org/acPapers/code/getPaper.cfm?paperID=11193&pdf=2006Full655.pdf>> (May 1, 2007).
33. Kennedy, Ana, Ollis, David Ollis, David , Rebecca Brent, "Cross-College Collaboration to Enhance Spanish Instruction and Learning." *Proceedings of the 2005 American Society for Engineering Education Annual Conference* (2005). American Society for Engineering Education. <[http://www.asee.org/acPapers/2005-1301\\_Final.pdf](http://www.asee.org/acPapers/2005-1301_Final.pdf)> (May 1, 2007).

34. Kim, Ernest M, "A Engineering Course Which Fulfills a Non-Major General Physical Science Requirement," *Proceedings of the 1999 American Society for Engineering Education Annual Conference* (1999) American Society for Engineering Education. <<http://www.asee.org/acPapers/99conf181.PDF> > (May 1, 2007).
35. Klein, D., and R. Balmer, "Liberal Arts and Technological Literacy," *Proceedings of the 2006 American Society for Engineering Education Annual Conference* (2006) American Society for Engineering Education. <<http://www.asee.org/acPapers/code/getPaper.cfm?paperID=11082&pdf=2006Full912.pdf>> (May 1, 2007).
36. Korzeniowski, K.A. and D. Mechtel, "Teaching Engineering to Non-Electrical Engineering Majors," *Proceedings of the 1998 American Society for Engineering Education Annual Conference* (1998). American Society for Engineering Education. <<http://www.asee.org/acPapers/00552.pdf>> (May 1, 2007).
37. Krupczak J.J., "Science and Technology of Everyday Life: A course in technology for liberal arts students," *Proceedings of the 1996 American Society for Engineering Education Annual Conference* (1996) American Society for Engineering Education. <<http://www.asee.org/acPapers/01535.pdf>> (May 1, 2007).
38. Krupczak, J.J "Demystifying Technology," American Society for Engineering Education, *PRISM*, October (1997) 30-34.
39. Krupczak, J.J., S. VanderStoep, L. Wessman, N. Makowski, C. Otto, K. Van Dyk, "Work in Progress: Case Study of a Technological Literacy and Non-majors Engineering Course," *Proceeding of the 35<sup>th</sup> ASEE/IEEE Frontiers in Education Conference*, October 19 – 22, 2005, Indianapolis, IN. Frontiers in Education. < <http://fie.engrng.pitt.edu/fie2005/papers/1469.pdf>> (May 1, 2007).
40. Kuc, R., "Teaching the non-science major: EE101 - The most popular course at Yale." *Proceedings of the 1997 American Society for Engineering Education Annual Conference* (1997). American Society for Engineering Education. <<http://www.asee.org/acPapers/01056.pdf>> (May 1, 2007).
41. Kuc, R, "Teaching the Non-science Major: EE 101-The Digital Information Age," *IEEE Transactions on Education*, **44**(2), 158-164 (2001).
42. Mahajan, A. and D.McDonald, "Engineering and Technology Experience for Liberal Arts Students at Lake Superior State University," *Proceedings of the 1996 American Society for Engineering Education Annual Conference* (1996) American Society for Engineering Education. <<http://www.asee.org/acPapers/01280.pdf> > (May 1, 2007).
43. Mikic, Borjana and Susan Voss, "Engineering For Everyone: Charging Students With The Task Of Designing Creative Solutions To The Problem Of Technology Literacy," *Proceedings of the 2006 American Society for Engineering Education Annual Conference* (2006). American Society for Engineering Education. <<http://www.asee.org/acPapers/code/getPaper.cfm?paperID=11191&pdf=2006Full575.pdf> > (May 1, 2007).
44. Nocito-Gobel J., S. Daniels, M. Collura, B. Aliane, "Project-Based Introduction to Engineering – A University Core Course," *Proceedings of the 2004 American Society for Engineering Education Annual Conference* (2004). American Society for Engineering Education. < [http://www.asee.org/acPapers/2004-907\\_Final.pdf](http://www.asee.org/acPapers/2004-907_Final.pdf)> (May 1, 2007).
45. Norton, M.G., and D. Bahr, "Student Response to a General Education Course on Materials," *Proceedings of the 2004 American Society for Engineering Education Annual Conference* (2004). American Society for Engineering Education. <[http://www.asee.org/acPapers/2004-873\\_Final.pdf](http://www.asee.org/acPapers/2004-873_Final.pdf)> (May 1, 2007).
46. Norton, M.G., and D. Bahr, "An Upper Division Course on Materials for Non-Engineering Students," *Proceedings of the 2002 American Society for Engineering Education Annual Conference* (2002). available: <[http://www.asee.org/acPapers/2002-2356\\_Final.pdf](http://www.asee.org/acPapers/2002-2356_Final.pdf)> (May 1, 2007).

47. Ollis, David, "A Lab for All Seasons, A Lab for All Reasons." *Proceedings of the 2000 American Society for Engineering Education Annual Conference*. (2000). American Society for Engineering Education. <<http://www.asee.org/acPapers/20381.pdf>> (May 1, 2007).
48. Ollis, David., "Technology Literacy: Connecting through Context, Content, and Contraption," *Proceedings of the 2005 American Society for Engineering Education Annual Conference* (2005). American Society for Engineering Education. < [http://www.asee.org/acPapers/2005-1313\\_Final.pdf](http://www.asee.org/acPapers/2005-1313_Final.pdf) >.
49. Orr, J.A., D. Cyganski, R. Vaz, "A Course in Information Engineering Across the Professions," *The 26<sup>th</sup> ASEE/IEEE Frontiers in Education Conference*, 1996, Salt Lake City, UT. Frontiers in Education. <<http://fie.engmg.pitt.edu/fie96/papers/122.pdf>> (May 1, 2007).
50. Orr, J.A., D. Cyganski, R. Vaz, "Teaching Information Engineering to Everyone," *Proceedings of the 1997 American Society for Engineering Education Annual Conference* (1997). American Society for Engineering Education. <<http://www.asee.org/acPapers/code/getPaper.cfm?paperID=823&pdf=01050.pdf>> (May 1, 2007).
51. Pisupati, S. Jonathan P. Mathews and Alan W. Scaroni, "Energy Conservation Education for Non-Engineering Students: Effectiveness of Active Learning Components," *Proceedings of the 2003 American Society for Engineering Education Annual Conference* (2003). American Society for Engineering Education. <[http://www.asee.org/acPapers/code/getPaper.cfm?paperID=6240&pdf=2003-2358\\_Final.pdf](http://www.asee.org/acPapers/code/getPaper.cfm?paperID=6240&pdf=2003-2358_Final.pdf)> (May 1, 2007).
52. Rosa A.J., P.K. Predecki, and G. Edwards, "Technology 21 – A Course on Technology for Non-Technologists," *Proceedings of the 2004 American Society for Engineering Education Annual Conference* (2004). American Society for Engineering Education. <[http://www.asee.org/acPapers/2004-604\\_Final.pdf](http://www.asee.org/acPapers/2004-604_Final.pdf)> (May 1, 2007).
53. Sarfaraz, A.R., and T.A. Shraibati, "Responding to the Expectations of Non-Technical Students," *Proceedings of the 2004 American Society for Engineering Education Annual Conference* (2004). < [http://www.asee.org/acPapers/2004-1387\\_Final.pdf](http://www.asee.org/acPapers/2004-1387_Final.pdf)> (May 1, 2007).
54. Dartmouth College, Hanover, NH 03755 USA, Course Descriptions, <<http://www.dartmouth.edu/~reg/courses/desc/index.html>> (May 1, 2007).
55. Dudley, J. M., and Bold, G. E. J, Top-down teaching in noncalculus-based introductory physics classes, *American Journal of Physics*, v64n4 (1996) 418.
56. Watson, G., The Science Concepts behind High Technology, <<http://www.physics.udel.edu/~watson/scen103>> Silicon, Circuits, and the Digital Revolution: Technology -- a means to an end, not an end in itself, <<http://www.physics.udel.edu/~watson/scen103/colloq2000/main.html>> (May 1, 2007).
57. Bloomfield, L., *How Things Work: The Physics of Everyday Life, 3rd Edition* (Wiley, New York, 2006).
58. Bloomfield, L. Explaining the Physics of Everyday Life. <http://howthingswork.virginia.edu/> (May 1, 2007).
59. Rogers, E. M. , *Physics for the Inquiring Mind*, Princeton University Press (1960).
60. March, R.H., *Physics for Poets*, First Edition, McGraw-Hill (1970).
61. Walsh, D., A. Demmons, D. Gibbs, "It's a Material World: An Engineering Experience for Non-Engineers," *Proceedings of the 1998 American Society for Engineering Education Annual Conference*

- (1998). American Society for Engineering Education. <<http://www.asee.org/acPapers/00348.pdf>> (May 1, 2007).
62. Weiss, P.T, and D. J. Weiss, "Hands-on Projects to Engage Non-engineering Students," *Proceedings of the 2001 American Society for Engineering Education Annual Conference* (2001). American Society for Engineering Education. <[http://www.asee.org/acPapers/00454\\_2001.PDF](http://www.asee.org/acPapers/00454_2001.PDF)> (May 1, 2007).
63. Disney, Katy, Vitkovits, S, Pam, R., "Designing a Portable Technical Literacy Course for Use in California," *The 25<sup>th</sup> ASEE/IEEE Frontiers in Education Conference*, 1995, Atlanta, GA. Frontiers in Education. <<http://fie.engrng.pitt.edu/fie95/4a6/4a62/4a62.htm>> (May 1, 2007).
64. Disney, K. and K. Kawamoto, *Engineering 3: How Everyday Technology Works*, Mission College, Santa Clara, CA <http://salsa.missioncollege.org/kawamoto> (May 1, 2007).
65. Krupczak, J.J., D. Ollis, "Technological Literacy and Engineering for Non-Engineers: Lessons from Successful Courses," *Proceedings of the 2006 American Society for Engineering Education Annual Conference* (2006). American Society for Engineering Education. <<http://www.asee.org/acPapers/code/getPaper.cfm?paperID=11081&pdf=2006Full744.pdf>> (May 1, 2007).
66. Ollis, David, Teaching Technological Literacy As A Quest, Or "Searching For Self In The Engineering Cosmos." *Proceedings of the 2006 American Society for Engineering Education Annual Conference* (2006). American Society for Engineering Education. <<http://www.asee.org/acPapers/code/getPaper.cfm?paperID=10896&pdf=2006Full647.pdf>> (May 1, 2007).
67. Krupczak, J.J., D. Ollis, R. Pimmel, R. Seals, G. Pearson, and N. Fortenberry, "The Technological Literacy of Undergraduates: Identifying the Research Issues," *Proceedings of the 35<sup>th</sup> ASEE/IEEE Frontiers in Education Conference*, October 19 – 22, 2005, Indianapolis, IN. <<http://fie.engrng.pitt.edu/fie2005/papers/1238.pdf>> (May 1, 2007).
68. Krupczak, J.J., D. Ollis, "The Technological Literacy of Undergraduates: Identifying the Research Issues," A Workshop Sponsored by the National Science Foundation, (2005). <[http://faculty.hope.edu/krupczak/Technological\\_Literacy\\_Report.pdf](http://faculty.hope.edu/krupczak/Technological_Literacy_Report.pdf)> (May 1, 2007).
69. *Taxonomy of Educational Objectives: The Classification of Educational Goals*; B. S. Bloom (Ed.) David McKay Company, New York, (1956).
70. Orlich, D. C., R. J. Harder, R. C. Callahan, and H. W. Gibson, *Teaching Strategies: A Guide to Better Instruction*. Houghton Mifflin, New York, (2004).

# Computer Applications in Mechanical Engineering

Author: Estelle M. Eke

Professor of Mechanical Engineering

California State University, Sacramento

## Introduction and Motivation

Juniors in mechanical engineering at California State University, Sacramento (Sacramento State) are required to take a 3-unit course titled “Computer Applications in Mechanical Engineering (ME 175)”. Prior to the fall 2000 semester, FORTRAN and MATLAB were the primary software packages used. The prerequisites are (i) any high-level programming language including C and C++, (ii) engineering materials, (iii) circuits and (iv) engineering mechanics – statics. The mode of course delivery is two 50-minute lectures and a 3-hour laboratory per week. Emphasis was on the introduction to numerical computation and assigned problems were solved on a PC/Workstation. Tests and final exams that rely heavily on computation were used to evaluate student performance; laboratory reports were used to assess writing skills. It was observed that a typical class was made up of two types of students; those who enjoyed programming, and students who considered programming as drudgery and were not motivated to do more than the minimum amount of work required to get a passing grade. The latter group also had difficulty relating the computer exercises in the textbook to real-world applications. After teaching this course a few times, the author decided to explore methods that might make the course more exciting to a greater number of students while remaining challenging. After some research it was decided that computer control of objects using microprocessors might be a good addition that will allow the students to test their programming skills, complement the techniques encountered in the numerical exercises, and at the same time lead to fun and challenging designs.

## Objectives

The objectives for ME175 are to:

- Provide students with a basic exposure to numerical methods.
- Use MATLAB as the software environment to conduct numerical analysis.
- Perform simulations using SIMULINK (a MATLAB toolbox).
- Reinforce principles of computer science, electrical engineering, mechanical engineering through open-ended robot design with the Basic Stamp (a microcontroller).
- Engage students in problem solving via team work.
- Provide a brief introduction to the design process.
- Give students an opportunity to demonstrate oral and written communication skills through oral presentations and final project demonstrations.

- Serve as a useful prerequisite for courses such as controls, mechatronics, modeling of dynamic systems, vibrations, and capstone design.

### Course Structure

Beginning in fall 2000 the 16-week semester course was restructured such that 8 weeks are devoted to the theory of numerical analysis and problem solving in the MATLAB environment. The numerical techniques covered in this course spanned topics encountered in a typical numerical methods textbook<sup>(1-3)</sup>. The topics covered are: introduction to linear algebra, the solution of systems of linear equations, curve-fitting, interpolation, and the solution of ordinary differential equations. In the next 2 weeks a brief introduction to controls and/or vibrations is given. The accompanying laboratory exercises involve simulations via SIMULINK, and provide some insight to model-based design for dynamic systems. In the last 5 weeks programming in the Parallax PBasic language, an interpreter for the Basic Stamp microcontroller<sup>(4-5)</sup> is introduced. An open-ended robot design project is also assigned. The students present their projects in week 16.

The course syllabus shown in table 1 provides more details regarding course structure. Four 50-minute tests are administered on the MATLAB and SIMULINK portions; two of these tests cover the theory and the remaining two test the students' programming skills. An oral presentation is required by each group in the preliminary phase of the robot design. The final examination consists of a powerpoint presentation, a demonstration of each group's project, and a technical report. Every student in a group must write a portion of the report so that his/her writing skills may be assessed. Students evaluate their peers' presentations and demonstrations. Grade distribution (MATLAB and SIMULINK 60%; project 40%).

Table 1. Course Syllabus

Lecture 1: Introduction to Computing Environment (SacCT, UNIX, Voyager, Windows); Review of Linear Algebra <a href="http://www.purplemath.com/modules/index.htm">http://www.purplemath.com/modules/index.htm</a>
Lab 1: Introduction to software (MATLAB) Driver, Plots, Conditional Statements; User-defined functions; Exercises with vectors and matrices
Lecture 2: Global variables; Data files: Read and Write
Lecture 3: Graphical User Interface (GUI) (Instructor notes)
Lab 2: Creating a GUI - Exercises with vectors and matrices
Lecture 4: Introduction to the PBasic Platform
Lecture 5: Review: Generating Plots in a GUI; Reading Data files
Lab 3: Completion of GUI Exercises with vectors and matrices; Introduction to the Basic Stamp Microcontroller
Lecture 6: Programming in PBasic; Subroutines (i.e. User-defined functions)
Lecture 7: Unavoidable Errors in Computing; Solving Systems of Equations
Lab 4: Microcontroller Basics with the Basic Stamp

Table 1. Course Syllabus continued

Lecture 8: Application of matrices – equations of motion for a robot arm Importing/Exporting MATLAB data to/from Excel
Lab 5: Microcontroller Basics with the Basic Stamp
Lecture 9: Least-squares Fitting of Curve to Data
Lab 6: Curve Fitting
Lecture 10: Additional examples in curve-fitting; Extracting equations using best-fit
Lecture 11: Interpolation
Lab 7: Fit curve and obtain equation for best-fit
Lecture 12: Numerical Integration of Ordinary Differential Equations ; Runge-Kutta Methods
Lecture 13: Analyzing non-stiff systems ODE45
Lab 8: Solving Initial Value Problems using ODE45
Lecture 14: Introduction to SIMULINK for solving Ordinary Differential Equations
Lecture 15: Application to Vibrations: Mass-Spring-Damper System using SIMULINK
Lab 9: Solving IVPs using SIMULINK
Lecture 16: Analyzing other systems using SIMULINK
Lab 10: Programming a microprocessor; constructing digital circuits
The Final Project (Lectures and self-paced labs) Technical Writing <ul style="list-style-type: none"> <li>▪ <a href="http://www.writing.eng.vt.edu/">http://www.writing.eng.vt.edu/</a></li> <li>▪ <a href="http://www.calstatela.edu/library/guides/3mla.pdf">http://www.calstatela.edu/library/guides/3mla.pdf</a></li> <li>▪ Oral Presentation 1, Gantt Chart</li> </ul>
Week 16: Final Presentation (Oral presentation 2 & Demo)

### A Review of Structured Programming via GUI Creation

The title *Computer Applications in Mechanical Engineering* encompasses a wide area and gives the instructor flexibility to choose from a variety of mechanical engineering applications. Since students at the junior level who take this course have already received exposure to various high-level programming languages such as C, C++, FORTRAN, JAVA and MATLAB, the first few lectures constitute a review of and/or introduction to MATLAB programming. Emphasis is placed on user-defined functions and the creation of a Graphical User Interface (GUI). Also Matlab requires that users have a good understanding of matrix operations. Thus a successful creation of a GUI such as that shown in Figure 1, demonstrates that the student (a) understands the importance of creating user-defined functions or modules that can be easily

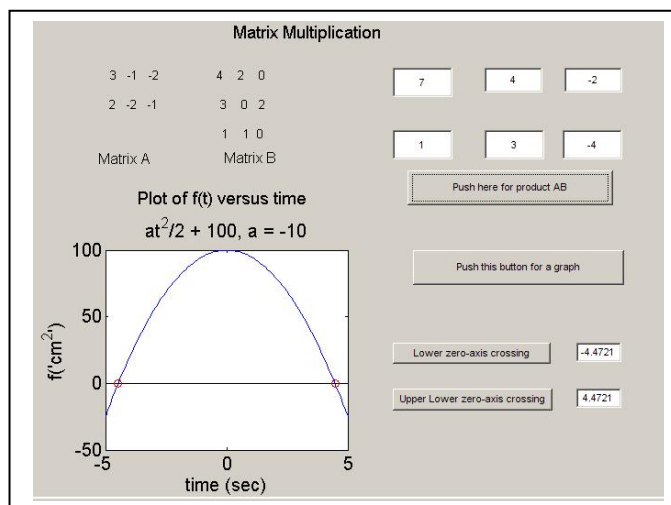


Figure 1. A Graphical User Interface generated in MATLAB



linked with other functions, and (b) can perform fundamental linear algebraic operations. Students are encouraged to use GUIs when presenting solutions to other laboratory exercises. About fifty percent of the students choose to use GUIs.

### Basic Stamp Projects

The open-ended projects assigned in the last few weeks will now be discussed. The instructor presents the guidelines for the projects and the entire class provides inputs in the preliminary phase. In some semesters multiple microcontroller-based projects are provided by the instructor, and depending on the complexity of a project, teams may consist of two, three or four students. At the end of each semester every student is required to give feedback on the entire process. This feedback is used to improve the guidelines for subsequent semesters. Microcontroller-based projects require the use of the Parallax Basic Stamp microcontroller.

### Background

Robots are used in many engineering design situations. In particular microprocessor control is basic to understanding how non-standard features such as servo control, programmable action, position sensing, response and PC-interfacing work. Microprocessor control is one of the foundation elements in mechatronics, a methodology used for the optimal design of electromechanical products. Mechatronics is multi-disciplinary, and allows today's engineering students to gain and use knowledge across the board in electrical, mechanical, and computer sciences, and in information technology.

In ME175, the students have been introduced to the Board of Education Basic Stamp 2 microcontroller and the Board of Education robot, Boe-Bot. A 5-week semester project allows students to demonstrate their programming skills by using computer control to maneuver two robots while performing a repertoire of actions. Videos of student projects completed since fall 2000 can be found at the author's web site<sup>(7)</sup>. Four examples of student projects are now presented. All projects may exhibit some of the additional features shown in Table 2 with a limitation that only materials supplied by or agreed upon by the instructor and class members are permitted.

Table 2. Other desirable features for each project

<ul style="list-style-type: none"> <li>▪ Communication with PC or Cell phone</li> <li>▪ Distance Detection</li> <li>▪ Drop-off or Edge detection</li> <li>▪ Infra-red detection</li> </ul>	<ul style="list-style-type: none"> <li>▪ Line following</li> <li>▪ Light Sensitive Navigation</li> <li>▪ Navigation with Infrared</li> <li>▪ Obstacle detection</li> <li>▪ Sound and/or light</li> </ul>
--	--

Project#1 Fall 2008: Each group of students must design autonomous vehicles to scatter and collect plastic balls. A sample board for the competition is shown in figure 2; color may be white or brown.

Two Boe-Bots are required and time limit to complete all tasks is 3 minutes.

BoeBot1:

1. Starts at least 60 cm away from the triangular ball depository area carrying 6 plastic balls. Ball diameter is 3 cm.
2. Carefully deposits all 6 plastic balls in the triangular area whose boundaries are marked by tape. Balls must be contained within the triangular area situated on the elevated board (elevation is 15 cm).
3. Carries a manipulator to scatter the balls.
4. Scatters the 6 plastic balls so that each ball crosses a line located 30 cm from the edge of the board. Any ball that enters a hole or rolls off the board will be randomly placed in front of the line as shown in the figure.

BoeBot2:

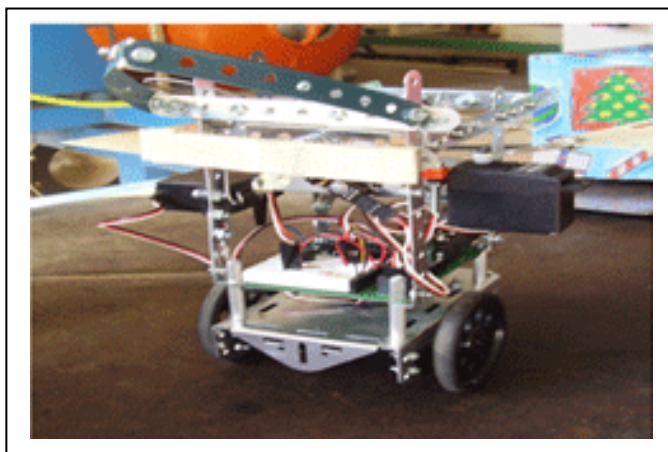
1. Starts in a designated location (see figure).
2. Finds a ball without touching any other ball.
3. Deposits the ball in any hole.
4. Repeats steps 2 and 3 at least once.
5. Returns to start location.
6. Does not fall off the elevated board.

Project by Group 11<sup>(8)</sup> – Fall 2008

Figure 3. Boe-Bot delivers balls to the table and performs ball scatter



Figure 2. 120 cm X 90 cm Competition Board and Specifications



The design and programming of Boe-Bot #2 was the most efficient of all designs presented. The robot accurately accomplished ball retrieval and deposit of ball repeatedly. The sensors and devices below the image in Figure 4 are used for ball detection and ball capture and the sensors

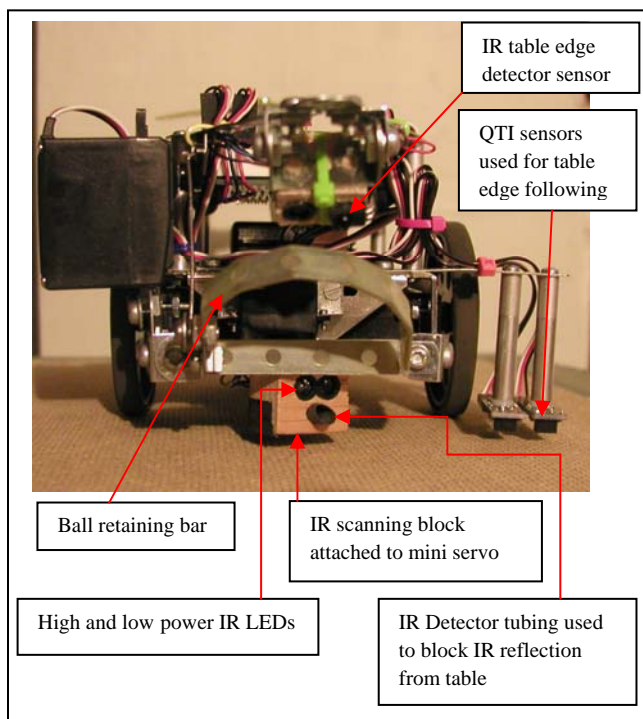


Figure 4. Boe-Bot #2 that detects and retrieves balls and drops the balls in designated hole.

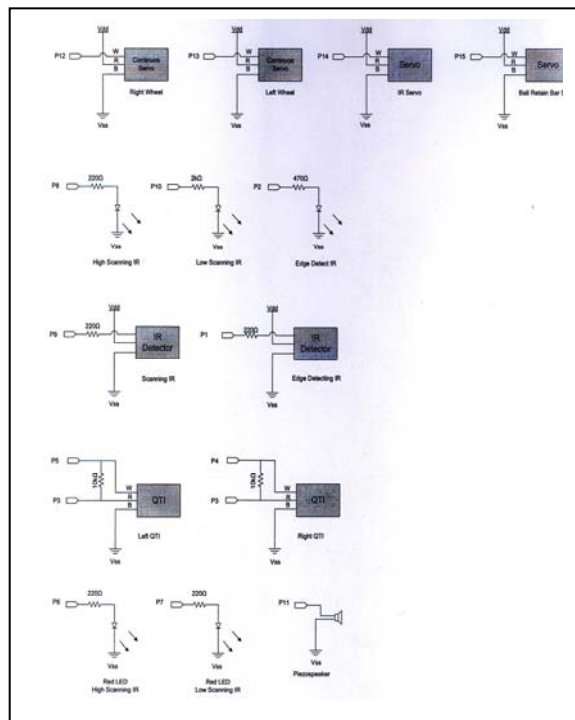


Figure 5. Schematic Diagram for Boe-Bot #2

on the right-hand side are used to navigate to the hole after ball capture. The schematic diagram for Boe- Bot #2 is shown in Figure 5.

#### Project#2 Spring 2008: Test-tube Retriever

This project was inspired by a robot workcell that consists of two robots [Puma 560](#) and [IBM 7575](#), and a conveyer system found at Professor Harry Cheng's<sup>(6)</sup> Integration Engineering Laboratory at the University of California at Davis. Some modifications were made as shown in the project guidelines. A team of four students worked on this project.

Goals: Boe-BotA should remove a test-tube full of beads off a rotating platform and pour the beads into another test-tube held by Boe-BotB. Boe-BotB then returns the test-tube back to the rotating platform. Repeat the process.

#### Guidelines:

- a) Maximum project area: 48 inches x 48 inches
- b) Elevation of rotating platform: between 4 and 6 inches

- c) 3 test-tubes of beads equally spaced on rotating platform
- d) Maximum time to complete process: 3 minutes
- e) Parallax QTI sensors are not allowed

Project by Group 2<sup>(9)</sup> – Spring 2008

The group was able to overcome several challenges in order to successfully accomplish the project. The biggest challenge was navigation since QTI sensors were not allowed. A custom printed circuit board (figures 6 & 7) with photoresistors, light-emitting diodes and resistors was

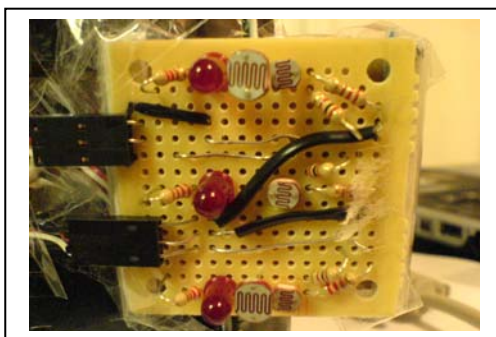


Figure 6: Custom line-follower Sensor

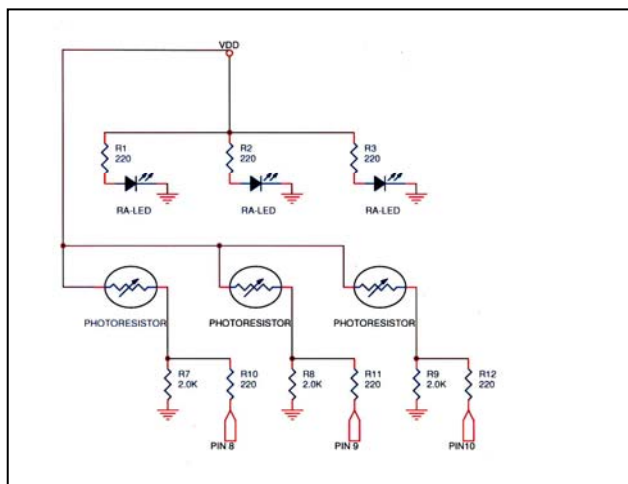


Figure 7. Line-follower Sensor Schematic

developed. The fabrication of the arm/clamp fixture for Boe-BotA (Figure 8), required utilizing one servo to satisfy both the vertical and rolling motions.

The process was successfully repeated and only one bead fell out during the transfer process (Figure 9). A video of this project can be found at the author's web site <sup>(7)</sup>.

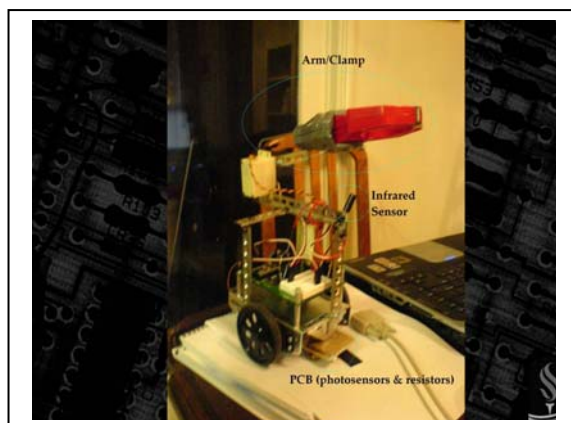


Figure 8. Robot #1 designed to remove test-tube of beads from a rotating platform.

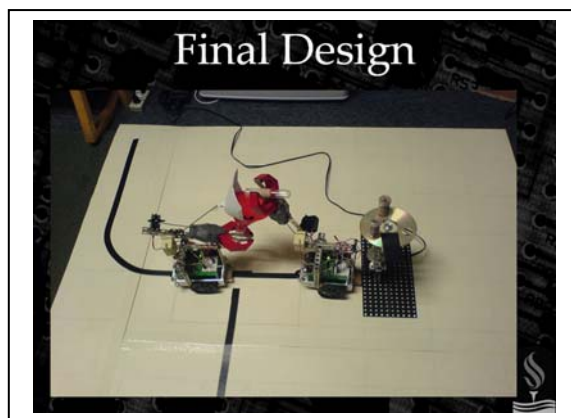


Figure 9. Robot #1 situated next to the rotating platform, transfers the beads from test-tube 1 through a funnel into test-tube 2 held by Robot #2.

In Fall 2007 two projects (#3 and #4) were assigned. Each group of students must select either the *basket ball shooting machine* or the *fire-fighting team*. Although the overall project is open-ended the main goals decided upon by the class are stated below.

### Project#3 by Group 7<sup>(10)</sup>: Basket-ball Shooting Machine

Goals: A container with at least one ball is transported by Boe-BotA. Boe-BotA traverses the edge of the court and parallel parks between two obstacles. Boe-BotB acquires the ball from Boe-BotA and shoots the ball into the hoop. At least one ball should enter the hoop in a maximum of three attempts.

#### Guidelines:

1. Minimum basket-ball court dimensions: 48 inches x 24 inches
2. Elevation of basket-ball hoop:  $\geq 10$  inches
3. Maximum diameter of basket-ball hoop: 4 inches
4. Minimum diameter of ball (ping-pong ) 1.5 inches
5. Minimum distance from hoop at which ball is released: 12 inches.

This project was designed to test the robot's ability to precisely and repeatedly launch an object.

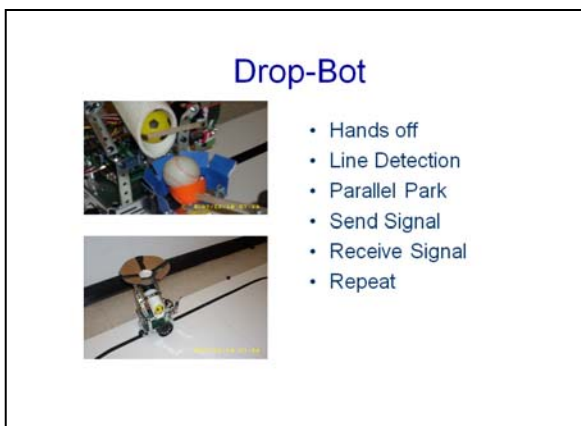


Figure 10. Delivery of ball from Boe-BotA to Boe-BotB and the basketball hoop elevated 12 inches above ground



Figure 11. A close-up view of the shooting mechanism attached to Boe-BotB

The navigation was accomplished using QTI sensors for line following. Boe-BotA (Figure 10) delivers the ball to Boe-BotB (Figure 11) and proceeds to the basket to catch the ball. This robot is capable of releasing one ball at a time. Boe-BotB receives a signal from Boe-BotA that triggers when it should move up to the shooting line that is located 3 ft from the 12-inch high basket. After launching the ball, Boe-BotB then signals to Boe-BotA that the ball has been launched before returning to the start position to receive another ball. The transfer of the ball from Boe-BotA to Boe-BotB was accurately and smoothly done. This team of three students

programmed Boe-BotB to shoot the ball into the basket repeatedly resulting in a continuous cycle.

The trajectory generated by the projectile could be analyzed to obtain the time taken to travel from point of launch to destination. Future projects will include analyzing different speeds with which the ball can be launched and the longest range that can be achieved.

Project by Group 5<sup>(11)</sup>: Fire-fighting Team

Goals: Boe-BotA detects fire in an area and Boe-BotB has to put out the fire. The area can be a city or a large office or dwelling place. Flame from a miniature candle represents the fire. The fire must be completely extinguished in the shortest possible time.

Guidelines:

1. Area dimensions: width > 4ft,  $4\text{ft} \leq \text{length} \leq 10\text{ft}$
2. Fire may be from a miniature candle, a flame imitator, or an infra-red sensor
3. Area options (a simulated city, a cluster of buildings, a grid of houses along streets)

This project generated a lot of interest. Group #5 was able to develop a unique idea that involved using transmitters to send a signal from Boe-BotA to Boe-BotB. The computer code was quite advanced as the group members had to research how to use transmitters and receivers, a topic that was not covered in the course. The grid shown had to be accurately mapped to ensure that Boe-BotA knows how many intersections it encounters along the grid as it searches for the fire. It can sense the fire on both sides of the grid. Boe-BotB was programmed to take the shortest path to the fire. Boe-BotB is equipped with a small electric fan powered by a 9-volt battery that rotates until the fire is in its line of sight and then extinguishes the fire.



Figure 12. The fire-fighter team. Boe-BotB moves to put out fire after receiving signal from Boe-Bot A

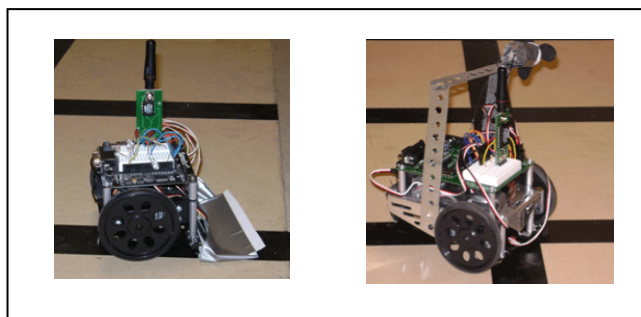


Figure 13. Boe-BotA and Boe-BotB

Some of the programming challenges included: (i) interference from the receiver which gave false directions, and (ii) complexity of code that made the Basic Stamp run out of Electrically Erasable Programmable Read Only Memory (EEPROM). The number of variables had to be

reduced and the smallest size possible had to be used for the variables in order to make optimal use of available memory. Also subroutines had to be efficiently written.

This group's design was the most efficient of the four groups that attempted this project. The time taken to detect and extinguish the fire was less than two-minutes on a 4-ft by 6 ft area consisting of 16 grids.

### Student Feedback

In this section some of the feedback provided by students at the end of the course is presented. Specific questions are not provided but rather students are asked to give comments and improvements that they think will be useful to incoming students and the instructor.

- Feedback 1: Start to work on the project immediately
- Feedback 2: Create a Gantt Chart and assign members to specific task at the start of the project; allow members to choose areas of expertise (the main areas are programming, design, build, powerpoint presentation creation)
- Feedback3: Keep the design simple and have a backup design
- Feedback4: Group members should be ready to collaborate and assist each other especially if one member is running behind schedule
- Feedback 5: Select materials that are inexpensive and will do the task
- Feedback 6: Use resources on the Internet and avoid re-inventing the wheel.

### Student recommendations on areas that can be improved by the Instructor

- Feedback 7: Assign the project earlier than the last 5 weeks as instructors in other courses may also assign projects; the robot project is sometimes time-consuming
- Feedback 8: Assign projects that require one robot for a 2-member group
- Feedback 9: Spend an extra lecture on the software features such as pulse-width-modulation (PWM) and Electrically Erasable Programmable Read Only Memory (EEPROM)
- Feedback 10: Give the same project to the entire class, it makes evaluating the projects easier.

### Implementation to Date – A Response to Student Feedback

The response to student feedback 7 – 10 follows:

- Response7: In the current semester, spring 2009, PBasic is introduced in week 3 (see Table 1 Course Syllabus). The project is assigned in week 12. It is preferable for the students to concentrate on the project in the last few weeks.
- Response8: After some discussions the conclusion is that the primary concern is the cost of the Boe-Bots. A Boe-Bot is available for loan to a group of two members. In extreme

circumstances the class may allow the use of one-robot but then the project has to be modified.

- Response9: As shown in Response7 above PWM and EEPROM are now being addressed and extra help will be provided as needed.
- Response10: This change was made last semester (Fall 2008) and it worked quite well. There was a lot of collaboration among groups even though each group's project maintained the unique characteristics presented in the preliminary phase.

## Conclusions

The inclusion of projects dramatically increases students' interest in the subject. Even at the beginning of the course students express their anticipation in the hands-on robot designs that the course offers. Faculty from the college of engineering, students from other disciplines, friends and families frequently attend the end-of-semester presentations. The graphical user interface is used in other courses and students appreciate how they were developed. Some students have applied these GUIs in courses such as statistics. The overall passing rate has greatly improved. It has been observed that the focus on numerical methods as a means of providing a foundation to real-world problem solving definitely complements the project approach. Students now understand the notion of acceptability of solutions, and are aware of errors encountered in computing and how it relates to real-world designs. The team approach reveals to each member that the learning experience consists of frustration, compromise, and ultimately success. Future development already approved by the department of mechanical engineering includes offering a similar structure in an introduction to computer programming course so that students may appreciate at the onset why understanding programming concepts is essential for engineers. Emphasis will also be placed on communication between MATLAB and the Basic Stamp2. This approach establishes a most important link between theory and implementation.

## Acknowledgments

Project examples presented in this paper were contributed by the following students: Aman Bains, Rod Baybayan, Alan Camyre, Ryan Dunish, Ian Hellstrom, Robert Jolley, Drew Mast, Cheng Moua, Matt Morrison, Garret Snedeker, Dustin Sutherland, Justin Pettenger, and Hung Tran.

## References

1. Fausett, L. (2007). *Applied Numerical Analysis Using MATLAB*. Upper Saddle River, New Jersey: Prentice Hall.



2. Gerald, C., & Wheatley, P. (2003). *Applied Numerical Analysis*. New York: Addison Wesley Longman, Inc.
3. Recktenwald, G. (2000). *Numerical Methods with MATLAB: Implementation and Application*. Upper Saddle River, New Jersey: Prentice Hall.
4. *What's a Microcontroller: Student Guide*. Version 2.2. Retrieved February 16, 2008 from Parallax.com Web site [http://www.parallax.com/Portals/0/Downloads/docs/books/edu/wamv2\\_2.pdf](http://www.parallax.com/Portals/0/Downloads/docs/books/edu/wamv2_2.pdf)
5. *Robotics with the Boe-Bot: Student Guide*. Version 2.2. Retrieved February 16, 2008 from Parallax.com Web site [http://www.parallax.com/Portals/0/Downloads/docs/books/edu/RoboticsV2\\_2.pdf](http://www.parallax.com/Portals/0/Downloads/docs/books/edu/RoboticsV2_2.pdf)
6. Cheng, H. (2007). *Faculty Page*. Retrieved June 18, 2007 from University of California Davis Web site <http://iel.ucdavis.edu/people/cheng.html>
7. Eke, E. (2009). *Faculty Page*. Retrieved February 16, 2009 from California State University at Sacramento Web site <http://gaia.ecs.csus.edu/~ekee/>
8. Jolley, R., Camyre, A., & Morrison, M. (2008). Undergraduate Students, Department of Mechanical Engineering, California State University at Sacramento: Sacramento, California.
9. Baybayan, R., Mast, D., Moua, C., & Tran, H. (2008). Undergraduate Students, Department of Mechanical Engineering, California State University at Sacramento: Sacramento, California.
10. Snedeker, G., Pettenger, J., & Hellstrom I. (2007). Undergraduate Students, Department of Mechanical Engineering, California State University at Sacramento: Sacramento, California.
11. Sutherland, D., Dunish, R., & Bains, A. (2007). Undergraduate Students, Department of Mechanical Engineering, California State University at Sacramento: Sacramento, California.

#### Biographical Sketch

Estelle Eke received a B.S. degree in aeronautical and astronautical engineering from Purdue University, an M.S. in mechanical engineering and materials science from Rice University, and a Ph.D. in aeronautical and astronautical engineering from Rice University. She worked for two and half years in the Spacecraft Navigation Section at the Jet Propulsion Laboratory in Pasadena, and then taught for two and half years in the Department of Aerospace Science Engineering at Tuskegee University before joining Sacramento State University. While at Tuskegee University, she received the Teacher of the Year award in Aerospace Engineering for two consecutive years. At Sacramento State, she was named Outstanding Teacher in the College of Engineering and Computer Science in 2000. She is currently Professor of Mechanical Engineering and teaches courses in the general areas of dynamics and control. Her research interests are in optimization and robotics. She also serves as a design judge for First Robotics competitions at the elementary and high school levels.

## **Teaming Multi-level Classes on Industry Projects**

Lizabeth Schlemmer & Jose Macedo  
Industrial & Manufacturing Engineering  
Cal Poly – San Luis Obispo

### **Abstract**

For the past few years we experimented with teaming students from a sophomore-level class and a senior-level class to work on industry projects. The classes are “work design” and “facilities design.” Projects are selected to require the application of knowledge from both disciplines. In addition, the projects are selected from small local companies. The intent of this paper is to describe the benefits and difficulties associated with this methodology. While specific classes in this experience are typical of an industrial engineering curriculum, the lessons learned and benefits could translate to other disciplines.

### **Introduction**

The use of Project Based Learning (PBL) has contributed to Cal Poly’s reputation of “learn by doing” for many years. As part of the Industrial Engineering (IE) curriculum at Cal Poly, students work in small groups with local companies on facilities related projects. The unique aspect of these projects is that students from a senior class and students from a sophomore class are partnered together to work on these industry based projects. These projects have been received favorably by the students, the local companies, ABET evaluators, and our industrial advisory board. As in many PBL activities, we observed that students develop better teamwork skills and better solutions to design problems. In addition, there are unique outcomes for the younger students including a higher commitment to their chosen major, and a better context for future classes. For the older students working with the younger students, the outcomes include review of lower level topics and enhanced supervisory skills.

This paper begins by reviewing the literature in the area of PBL and teams, describes the project and processes involved in these project teams, and delineates lessons learned from both the instructor’s and the student’s points of view. Areas of future research will also be discussed.

### **Review of Literature**

Most engineering schools use team based projects, or laboratory assignments to help students develop skills necessary for their professional careers. Teamwork skills have traditionally been developed by assigning students to teams. To some extent, this approach does produce results, but a better approach was undertaken at the University of Dayton<sup>[4]</sup> where student teams were instructed on teambuilding and leadership. One of their suggestions was not only to instruct, but to give students opportunities to work on teams where students refine their skills as they mature through the engineering program. Many researchers have struggled with the difficult task of assessing teamwork and other soft skills involved in multi-disciplinary PBL teams. Plumb and Sobeck<sup>[10]</sup> put together a framework for developing assessment tools. They urge instructors to develop a rubric or protocols to track performance over time.

Teamwork in PBL is a unique case in that the teams are usually working on more difficult, time consuming problems. When PBL is used students achieve desirable outcomes. Several researchers at the University of Madrid<sup>[7]</sup>, found that PBL used in the design of electronic systems increased interest in electronics, increased academic performance, and produced better design solutions. In addition, situational factors were found to influence the outcomes of PBL activities for junior engineering students<sup>[6]</sup>. These situational factors include the type of project selected, the learning of the individual student, and the ability of students to adapt to working under time pressure.

Engagement is often cited as an important component of learning in PBL. In the Civil and Chemical Engineering school at RMIT, researchers<sup>[5]</sup> examined the factors that effect engagement in a PBL environment. They examined first year engineering students and identified four factors that helped students engage in a project. The first factor is that students need “interesting work.” The second is that students must understand the structure of the problem with clearly defined expectations. Thirdly, students work best when they feel connected to other students in their groups. Lastly, students require guidance and orientation to their new university environment.

Several studies have looked at team structures that include individuals from varying educational levels. Some have included graduate students on teams with undergrads, while others have grouped high school students with university seniors. At Boise State University<sup>[9]</sup>, faculty, post-doc, graduate students, undergraduate engineering, and undergraduate technology students are put on teams together in laboratory courses. Although only in the beginning stages of this curricular change, these researchers feel it will be an effective method to simulate the working environment for the future graduates. Adams, Zhang and Burbank<sup>[1]</sup> placed undergraduates and graduate students together on teams with the explicit goal of preparing undergrads for graduate study and research. They observed both increasing graduate enrollment and higher quality of graduate students after implementation of these teams. The School of Electrical and Information Engineering at the University of South Australia experimented with grouping seniors with high school students on a design project<sup>8</sup>. The projects were university sponsored, but industry generated. The high school students reported better learning of technical skills and the older students developed management and communication skills. In addition, the younger students felt they could make more informed career choices.

Related to teaming in PBL, the use of teaching assistants (TA) as substitutes for faculty in guiding PBL experiences was explored at Delft University of Technology in the Netherlands<sup>[2]</sup>. There were clear advantages delineated, which included the ability of TA's to establish good social and peer relationships with student teams. In addition, TA's were unable to give direct step-by-step guidance, which proved to be an advantage to learning for the student teams. The researchers stress the importance of thorough recruiting and training of the TA as an important success factor. Also, Crosby, Ibekwe, Li, Pang and Lian<sup>[3]</sup> developed a tiered mentoring approach as part of a larger research project. The faculty mentor the graduate students who in turn mentor undergraduates. In turn, the undergraduates mentor high school students. These researchers state that they feel confident this type of activity will increase recruitment and retention.

PBL and teaming have clear advantages to students, and it seems that even grouping students at different experience levels can achieve excellent outcomes. This research takes these experiences one step further to look at a sustainable system to enhance learning outcomes.

## The Courses and Projects

The two courses described below are only two of many courses in the IE curriculum that use PBL. These courses are the first in which we grouped senior students from one class with sophomore students from another to work on industry generated projects.

For more than ten years the senior facility design class has conducted projects for local companies. The students work in teams of four to seven students to produce an improved facilities design expressed in a report and a presentation. This capstone senior level class requires that students draw on their knowledge from many IE topics including inventory control, project management, ergonomics, quality, work design and economics. Clients are usually small manufacturing firms in the San Luis Obispo County area, but also companies in Stockton and the LA area have participated. Typically these firms are so small that they would never have had the opportunity to see IE topics applied in a systematic manner by knowledgeable individuals. An overwhelming number of the clients have been pleased with the results. Table 1 is a partial list of companies and projects. Some of these companies have hired IE's after realizing the contributions IE's can make to a company's efficiency. In addition, most companies have implemented at least some of the recommendations made by these students.

**Table 1 - Sample Projects**

Company	Location - CA	Company Type	Project Description
C&D Aerospace	Santa Maria	Aerospace	Redesign of an assembly cell
Hardy Diagnostics	Santa Maria	Biomedical	Design layout for a new location
Dioptics	San Luis Obispo	Distribution	Design new warehouse
Road Home	Oceano	Non-Profit	Design a homeless shelter/campus
Left Coast T-Shirt	San Luis Obispo	Screen printing	Re-layout production floor to incorporate new machine
SLO Roasted Coffee	San Luis Obispo	Food	Design new layout to incorporate new packaging process
UVS Thrift Store	San Luis Obispo	Non-profit	Re-layout and methods improvement
Moulton Logistics Mgmt	Van Nuys	Distribution	Redesign of reverse logistics area
New Life Church	Arroyo Grande	Non-Profit	Design of new youth center
Jamba Juice	San Luis Obispo	Retail	Redesign of retail location
Diamond Foods	Stockton	Food	Redesign assembly line production area
Wasco	Santa Maria	Electronics	Design of a new facility
Corbett Canyon Winery	San Luis Obispo	Winery	Re-layout of a bottling line
Fountains of Living Waters	Santa Maria	Wholesale	Layout of a new facility

Students also learn first hand, topics that are difficult to teach in the classroom. For instance, students learn the importance of positive interactions with clients, methods of dealing with project uncertainty, real deadlines where more than a grade is at stake, and team conflict resolution in real time.

The second course, Work Design, is one of the first major course IE students take. In this class students learn basic methods of time studies, continuous improvement procedure, and lean manufacturing concepts. They are also introduced to ergonomics and work station design. For many years students in this class have been applying these concepts to real life situations. Often students find a project themselves, and occasionally the instructors provide a project. Whatever the project, students are encouraged to recommend a justified improvement to an existing procedure using time studies and other quantitative measures.

Because these two courses have a history of working on real life projects for companies, a couple years ago we experimented with combining the projects and students so that several students from each class work on the same project. Generally the teams are made up of four upper level students and two lower level students. The tasks are loosely divided between facilities design and work study, but these are naturally integrated requiring students to interface for project completion.

Currently, not all students participate in these multi-level teams. Generally there are seven or eight facilities teams, of which four have students from the lower level class. In addition, there are seven or eight teams in the work design course, of which four are students participating on teams with the seniors.

As an example, a student team made up of five seniors and two sophomores worked for a local winery developing the layout of a new bottling line. Initially, the students visited the winery for a tour. This was followed by the upper level students creating a Statement of Work as learned in their project management class. This was discussed with the client and then expanded to include descriptions of tasks, deliverables, and a work breakdown structure. Work design students created process charts, and collected time study data on the processes. The facilities design students used this data to create a simulation using Promodel® (a discrete event simulation software that includes graphics) that illustrated bottlenecks and justified task automation. All the students in the group worked on research of automation equipment and developing alternative layouts for the line. The facilities student performed economic evaluation and evaluated quality issues. Work design students created lean manufacturing work stations equipped with 5S shadow-boards<sup>[11]</sup>. All students worked on recommendation for ergonomic improvement. A comprehensive report, approximately 100 pages long, a professional presentation, and a physical model of the recommended line was delivered to the client after six weeks of intense project work. The quality of the report was high and the client was pleased with the many creative cost-benefit justified ideas.

## **Learning Outcomes**

The fact that these courses use PBL to teach some valuable topics should not be overlooked, but in addition, the students are learning topics that are unique to this multi-level teaming experiment. Below these outcomes are delineated into those achieved by everyone participating in the multi-level teaming, those achieved by the senior students, and those achieved by the sophomore students. The description of each outcome is followed by a quote from a student in the classes. These quotes were collected as part of an anonymous survey of the participating students. Summary data from this initial survey is also included where appropriate.

Outcomes for all students. Students in both classes are heavily engaged in the projects and thus are acquiring skills at a high level. They are also learning enhanced teamwork skills by dealing with individuals different than themselves.

- *Working with students in 443 (facilities design) gives the 223 (work design) students an idea of what sort of workload to expect and the complexity and various challenges of solving a specific problem within a team of people with various backgrounds and experience levels. (Sophomore Student)*
- *It was a lot of work, but I would definitely do it again. (Sophomore Student)*
- *I really thought that the class was a lot of fun and a great learning experience. (Sophomore Student)*
- *I really enjoyed working with the upper classmen. (Sophomore Student)*

When the younger students were asked “Did you learn more from this project than other projects you worked on?” 71% answered, “I think I learned a lot more working with the seniors.” In addition, 68% of the students reported that they worked “very hard” on the project.

Outcome for senior students. Seniors learned supervisor skills and had a chance to refresh their memory of topics learned as sophomores.

- *I did learn how to supervise and delegate jobs through an understanding that they were lower classmen. (Senior Student)*
- *It was tough to get them to find their own work to do (basically we didn't want to hold their hands). Definitely learned a lot about delegation. (Senior Student)*
- *It was nice to have upper classmen in my group as they were able to guide us through the hard aspects of the projects. (Sophomore Student)*
- *I liked working with them because they refreshed my memory on how to do time studies. (Senior Student)*

Outcomes for sophomore student. Sophomore students expressed increase knowledge of the curriculum, development of mentoring relationships, and an increased dedication to their chosen major.

- *The seniors as well as the project defined my interest and choice of IE as my major (Sophomore Student)*
- *It helped give an understanding of what would be coming in the future. (Sophomore Student)*
- *I loved hanging out and working with upper classman; it helped me set some goals of what I want to be doing in the next couple years while I'm at Cal Poly. I thoroughly enjoyed it. :) (Sophomore Student)*
- *I didn't just learn about work study in class, I also gained knowledge from the project and the upper classman. (Sophomore Student)*
- *I remember during the project, I became good friends with the seniors in the group (Steve and Edgar) and they both basically became mentors to me. (Sophomore Student)*

- *After this project, I was sold on Industrial Engineering as the major for me. (Sophomore Student)*
- *It was great to get a preview of what we would be learning later on. (Sophomore Student)*
- *The upper classman and working with the company showed me how complicated and how many different perspectives IE's have to pay attention to when doing a job for a company. (Sophomore Student)*
- *Working with seniors put extra pressure on me to want to perform better for my peers. (Sophomore Student)*

When asked “Did the project change your opinion of IE as a career?” 89% answered “It made me more interested in my major.” When asked “Did you feel appreciated?” 78% answered “Yes, they appreciated me.”

### **Lessons Learned**

By combining students from different class levels several important objectives were realized, but there are also some important lessons we learned. These include techniques that proved helpful and areas of caution.

Project definition. We, as the instructors of these classes, recruit companies to participate with appropriate projects before the term begins. These projects must be of the appropriate scope, size as well as include some level of ambiguity. Projects must include IE tasks such as time studies, ergonomic evaluation, and facilities implications. Careful selection of projects proved to be critical for student success. Some facilities projects do not have tasks for work design students, these projects are still being worked on, but no sophomore students are assigned to these teams.

Company participation. Companies that participate in these projects are asked to have one contact person who can communicate with students. In addition, they must attend two presentations: an interim presentation and a final presentation. It is very important that companies are told in advance of these expectations. In some projects, the companies are shocked at the sheer number of questions students can generate. We, as instructors, try to encourage students to think hard before they ask too much, but sometimes communications can get burdensome for the companies. In these few cases, the companies must be able to deal with the instructor directly so that adjustments can be made.

Course structure. These projects work best if the two courses have lab activities that are scheduled concurrently. The groups must meet together and the difficulty of scheduling these meetings is minimized if students are guaranteed to be available at the same day and time. The two courses are separate and are run by different instructors. Each class has topics that must be addressed and lab activities that must be performed. The difficulty in scheduling should not be minimized.

Timing of instruction. One of the difficulties encountered when using any projects in a course is that it is not easy to cover all the topics in time for application to the project. This is especially true in a quarter system. In the senior design class this is solved by intense lecturing during the

first five weeks of class and project work during the last five week. This structure is not possible in the work design class, yet some important topics are needed at the beginning of the quarter. In order to solve this, we cover time studies very early, and this may sacrifice a logical sequence of topics.

Teamwork instruction. It is very important to introduce this multi-level teaming to the classes in a way that they understand the reasons behind the procedure. The seniors need to understand that the sophomore students are full team members. The younger students will be assigned specific tasks, but should be respected for their contribution and even encouraged to stretch themselves by creative problem solving. The seniors are also asked to consider themselves teachers and mentors of the younger students. In one group, the younger students were not treated as equals and the faculty members did not intervene in time to remedy the problem. The younger students were demoralized and hated being part of the team. In addition, the seniors on this particular team had major conflicts and the poor quality of their final presentation reflected their dysfunction. The younger students need to understand the time commitment and complexity of the project. It is possible that not all sophomore students can handle the intensity of these projects.

Assignment of individuals to teams. We have found that it is important for the faculty involved to assign teams and not to allow students to choose their own teams. For the seniors on the teams, there must be students with a mix of skills and experiences. For the sophomores, the students should be informed of the complexity of the task and have the option of working with the seniors on these more complex projects. In the sophomore class students are asked to volunteer for the facilities projects, and typically there are a greater number of sophomores wanting to do the complex projects than there are spots on the project teams.

Use of electronic communications. Because the students are in separate classes, communications is sometimes a challenge. The use of communication devices such as Blackboard or Google Groups has enhanced document transfer and simplified interactions.

Good teamwork techniques. The students on the teams are encouraged to practice good teamwork techniques. Students are required to create an agenda for each meeting and keep track of activities using project management. In addition, teams are encouraged to have team-bonding activities that increase the cohesiveness of the teams. Students also must deal directly with team conflicts. We, as instructors, have had to gather students together to openly discuss conflicts. This is quite difficult, and not all instructors are comfortable in the role of mediator.

Communication between instructors. The communications between the instructors should ideally be frequent and easy. In our classes, the instructor for the facilities class organizes the companies and the schedules, but discussion about team membership and dealing with problems along the way is the responsibility of both instructors.

The number of projects. These projects are managed as part of the regular teaching load of the faculty. There are approximately 250 students in the IE major at Cal Poly, this means that each quarter there will be as many as ten student groups working with companies. This requires



considerable coordination with the companies and motivation of the teams. This multi-level teaming may be easier to sustain if additional resources are allocated.

Procrastination. Students tend to procrastinate. Because of the nature of these complex problems, procrastination can really hurt the final product. In addition, because the projects are ambiguous by design, students have a hard time at the beginning of the project moving ahead with a solution methodology. Due to the nature of the project, if the upper classmen are procrastinating the lower classmen will be adversely affected. The way we have dealt with this problem is to push students hard to show early analysis and data collection, but we still struggle to get some students teams moving early enough.

Exposure of sophomores to seniors. Sometimes the students in the work design class are freshman; as young as 18-years old. Seniors must remember this when dealing with the younger students, they must be careful about mature activities such as drinking and partying. We, specifically warn senior students to be mindful of the age of their teammates.

## **Conclusions and Future Research**

We found that teaming lower level IE students with upper classman led to several desirable outcomes. For the younger students they gained a greater appreciation for their choice of major, they develop mentoring relationships, and they develop knowledge of technical aspects of IE. Upper classman also acquired important skills, particularly management skills and relearning of topics. Both age groups of students expressed satisfaction in the experience. Although the activities described in this paper are done with IE students, other disciplines can realize similar benefits by teaming lower and upper level students together on project teams.

We have been able to sustain these project teams for several years. It is the hope that as we refine the procedures and prove the benefits, these multi-level teams will become an official part of the IE curriculum.

Although we have seen much success in their multi-level teaming, there are still more opportunities to refine the procedures. We are currently in the middle of a quarter where students have been asked to fill out surveys on abilities in teamwork, supervision and other observed outcomes of the multi-level teaming. We administered the survey to all students in the two classes, approximately half of them are participating the multi-level teaming while the other half are working on teams with their classmates. We are hoping to find differences in the groups dependent on the team type.

In addition to students from these two classes, it seems feasible to have students from other courses working with companies on multi-faceted teams. Currently, courses in simulation, design of experiments (DOE), human factors, and project management are working on team projects. It is conceivable that these classes could be partnered together to work on complex problems for companies with good results.

## List of References

1. Adams, R., Zhang, J., and Burbank, K. (2007). Graduate / Undergraduate teaming of ECET students for applied research via senior projects. *Proceedings of the 2007 ASEE Conference*, 2357.
2. Andermach, T., Saunders-Smit, G. (2006). The use of teaching assistants in project based learning at aerospace engineering. *Proceedings from the 36<sup>th</sup> ASEE/IEEE Frontiers in Education Conference*, S3D-11.
3. Crosby, K., Ibekwe, S., Li, G., Pang, S., and Lian, K. (2007). Tiered mentoring in a cross-disciplinary and multi-institutional research project. *Proceedings of the 2007 ASEE Conference*, AC 2007-1589.
4. Edmonson, C., Summers, D., (2007). Integrating teamwork across the curriculum. *Proceedings of the 2007 ASEE Conference*, AC 2007-348.
5. Hadgraft, R., Goricanec, J. (2007). Student engagement in project-based learning. *Proceedings of the 1<sup>st</sup> International Conference on Research in Engineering Education, ASEE*, ISBN: 0-87823-193-5.
6. Hsu, R. C.,; Liu W. (2005). Project based learning as a pedagogical tool for embedded system education. *Proceedings of the International Conference on Information Technology Research and Education, Hsinchu, Taiwan*.
7. Macias-Guarasa, J., Montero, J. M., San-Segundo, R (2006). A project-based learning approach to design electronic systems curricula. *IEEE Transactions on Education*, 49(2), 389-397.
8. Nafalski, A., Nedic, Z. (2008). Final year projects with involvement of industry and high schools. *38<sup>th</sup> Annual ASEE/IEEE Frontiers in Education Conference, NY*, T4C-7.
9. Parke, S., and Jozwiak, J. (2001) A unique, multi-level-team microfabrication learning environment at Boise State University. *Proceedings of the Fourteen Biennial University/Government/Industry Microelectronics Symposium*, 114-116.
10. Plumb, C., and Sobek, D. (2007). Measuring student ability to work on multidisciplinary teams: building and testing a rubric. *Proceedings of the 2007 ASEE Conference*, AC 2007-803.
11. Rooney, S. A., Rooney, J. J. (2005). Lean glossary. *Quality Progress*, 38(6), 41-47.

## Biographical Information

**LIZABETH T. SCHLEMER** is an associate professor of Industrial and Manufacturing Engineering at California Polytechnic State University in San Luis Obispo. She received her Ph.D. in education from University of California, Santa Barbara, an MBA and an MS in Industrial and Systems Engineering from university of Southern California and a BS in Industrial Engineering fro Cal Poly, SLO. She has 10 years of industrial experience working of Unocal Corporation. She has been teaching at Cal Poly, SLO for 15 years. She teaches a wide range of subjects from Engineering Economy to Facilities Planning and Design. She has developed good relationships with local industry and provides her students with opportunities to participate in real projects for real clients. She lives in Santa Maria, is married with three children. One of her daughters is a fourth year in the IE program at Cal Poly.

**JOSE A. MACEDO** is an associate professor of Industrial and Manufacturing Engineering at California Polytechnic State University in San Luis Obispo. He received his Ph.D. in industrial engineering from Lehigh University, an M.S. in mechanical engineering from the University of California at Berkeley, and a B.S in mechanical engineering from the Catholic University of Peru. He has taught courses on statistical design and analysis of experiments, quality engineering, work measurement, machine vision, robotics, manufacturing automation, and manufacturing processes, both at the graduate and undergraduate levels. He is a certified instructor of the MIT Lean Academy and instructor for the Institute of Industrial Engineers (IIE). He has been president of the

Industrial Engineering Division of the American Society for Engineering Education (ASEE) at the national level. During the summers of 2000 and 2001, he worked with the machine vision group at the Jet Propulsion Laboratory JPL-NASA in Pasadena, California. In 2008 he spent six months as a Fulbright scholar in Panama working in the areas of quality, six-sigma, design of experiments and lean. He has many publications in engineering journals and conference proceedings. He is a professional engineer (P.E.) registered in the state of Texas, and has engaged in consulting with the following companies: Boeing, Honeywell, Iomega, Texas Instruments, Toro, and Sequenom.

## Redevelopment of a Systems Engineering Course into Blended (Hybrid) Mode

Kurt Colvin  
College of Engineering  
Cal Poly, San Luis Obispo

### Abstract

Research in the area of teaching methods supports the use of an appropriately designed blended mode to supplement a traditional lecture format. A blended or hybrid course, by definition, reduces face-to-face (f2f) "seat time" so that students may pursue additional teaching and learning activities outside of class, typically online. This paper describes the process and experiences of the redesign of a systems engineering course into a blended course. To be successful, the redesign requires careful application of pedagogical concepts and continuous improvement using an understanding of how students learn. This paper is a status report of an ongoing effort.

### Introduction

While distance education programs have exploded in recent years, a new trend within the field has emerged: blended or hybrid courses. A hybrid course builds on a traditional, face-to-face course incorporating online elements, using the same course management software that underpins courses taught entirely online. This model can appeal to a wide range of instructors, even those who are critical of online learning, and can be used to improve a variety of courses or solve particular problems. Some universities have used the hybrid model to solve classroom space shortages, to improve communication between students and instructors in large classes, and to address students' needs for computer and technology literacy (Lindsay, 2009).

There is a wide range of interpretations of how to define blended learning (Boyle, 2005; Whitelock & Jelfs 2003; Driscoll 2002). These arise partially from the different motives that underpin the use of a blended learning approach. These vary from cost-saving considerations to pedagogical considerations of producing more effective methods of learning. At the base of these descriptions is usually a mixture of asynchronous-based (online) learning and traditional face-to-face learning.

The intent of this paper is to describe a method for redesigning an existing, lecture-only f2f course into a 50-50 blended course and to share lessons learned in the process.

### Background

#### *Existing Systems Engineering Course*

Aerospace 510 (Systems Engineering I) is an introduction to the system engineering (SE) discipline for graduate students. SE is truly the integration and orchestration of all engineering activities to meet customer needs. One widely-accepted definition of SE is given by the Department of Defense (2001).

*Systems engineering is an interdisciplinary engineering management process that evolves and verifies an integrated, life-cycle balanced set of system solutions that satisfy customer needs.*

While SE is a traditional topic in many engineering programs and some universities offer entire programs in SE, we began offering this course in 2005. Since then, the course, offered approximately twice a year, has slowly evolved and developed into a traditional, 4 hours/week, 40 hours/term lecture course. The course is open to all graduate students across the college of engineering, but is comprised primarily of aerospace, industrial and civil engineering students.

I have taught this course for 6 times, both in a conventional classroom setting and with the addition of remote students in an in-class/distance-learning combined setting. While the lecture content was relatively well-developed, there were many opportunities for continued improvements. For example, a rich selection of case studies exists to emphasize both system development successes (i.e., Boeing 777) and failures (i.e., The California Statewide Automated Child Support System). While a traditional course allows for outside reading and in-class discussions, many of the case studies have engaging multimedia components that spur other learning opportunities for students. In a traditional setting, it is not feasible to employ the full potential of these opportunities.

#### *Focused Continuous Improvement*

The mission of the Center for Teaching and Learning (CTL) is to enhance teaching and learning by providing an environment and resources to:

- Create opportunities for faculty and staff to enhance teaching and learning skills.
- Promote cross-discipline discussion and collaboration, sustain an interactive community of faculty and staff learners.
- Encourage awareness of issues that affect both the academic community and its disciplines.
- Help faculty and staff maintain currency in their chosen fields.

The CTL provides teaching and learning support for faculty, interacts with colleges and departments, conducts workshops and classes, provides learning communities, publishes newsletters, and administers grants (Cal Poly, 2009). The current course redevelopment effort was made possible by the support of the Cal Poly CTL.

#### *Backward Design*

Very few of us, as engineering educators, have had a formal course in pedagogy. Therefore, in addition to the challenging task of developing new and improving existing courses, we also have to battle with our lack of formal training in the area of course design. However, there is a rich field of instructional design literature from which we can draw.

Backward course design is one method that can guide instructors as they struggle with designing their own courses or even an individual lecture (McTighe & Wiggins, 2005). The steps in backward course design include: (1) identify the desired results, (2) determine the acceptable evidence, and (3) plan learning experiences and instruction (See Figure 1.). By focusing on the

end results first, we can help students to see the importance of what they are learning and make our activities more meaningful and based less on what we have seen others do or how we were taught.

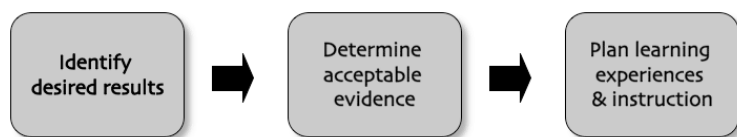


Figure 1. Backward Design (McTighe and Wiggins, 2005)

Backward design begins with the end in mind and asks the questions: What enduring understandings do I want my students to develop? How will my students demonstrate their understanding when the unit is completed? How will I ensure that students have the skills and understand the concepts required on the summative assessment?

Instructors pose these questions at the earliest stages of the course planning process. By beginning with the end in mind, instructors are able to avoid the common pitfall of planning forward from activity to activity, only to find that some students are prepared for the final assessment while others are not. Using backward design, teaching for understanding, and requiring students to apply and demonstrate their learning are not new concepts. Many of the best instructors have been using this approach, even if they didn't have a name for it.<sup>3</sup>

What should students know and be able to do?

In stage one we consider our goals, examine established content standards and review curriculum expectations. What content is worthy of enduring understanding? Due to the limited amount of time in a quarter, we must make choices and priorities.

How will we know if students have achieved the desired results?

Begin with the question: "What would we accept as evidence that students have attained the desired understandings and proficiencies?" Before designing specific units and lessons, consider up front how the instructor will determine if students have attained the desired understandings.

What activities will equip students with the needed knowledge and skills?

Finally, ask the question: "What materials and resources are best suited to accomplish these goals?" With clear identified results and appropriate evidence of understanding in mind, it is now the time to select and fully develop the most appropriate instructional activities.

## Method

In the fall of 2008, I enrolled in a CTL Technology Initiative-Phase I course. The intent of this course was to help faculty (the "students" in the course) understand and develop a blended course. The objective was accomplished by providing a blended course to the enrolled students (A blended course to teach how to develop a blended course, if you will). The students and instructors met F2F each week, followed by asynchronous assignments to complete both individually and in collaboration with fellow classmates, completed online using Blackboard. The instructors of the Phase I course used backward design and other pedagogical methods concurrently as they taught those concepts as the content of the course.

For example, one of the learning objectives of the Phase I course was:

- Participants will be able to plan the method of teaching based on objectives and assessment that will facilitate learning using technology.

Lessons were focused on meeting this learning objective. The students then performed small planning pieces of their respective courses and submitted those plans for evaluation by the instructors and fellow classmates.

### *Backward Design of Aero 510*

At the completion of the Phase I course, the basis of the SE course redesign was in place. In the weeks to follow, the model of backward design and appropriate uses of technology to enhance student learning were implemented using the existing content of Aero 510 as a baseline.

For example, in Aero 510, one of the topics is requirements management. (*Requirements management is the process of eliciting, documenting, analyzing, prioritizing and agreeing on requirements and then controlling change and communicating to relevant stakeholders*) (Blanchard & Fabricky, 1990). In the process of redesign, the identified learning outcomes were explicitly identified:

After successfully completing this module, students will be able to:

- Describe relevant characteristics of requirements
- Evaluate requirements for adherence to relevant characteristics
- Describe the requirements discovery process
- Define requirements management
- Collaboratively write requirements

The next step, determining acceptable evidence, was performed. For the learning outcomes above, acceptable evidence was identified as:

- Complete and submit homework questions related describing relevant characteristics of requirements
- View flawed requirements and submit improvements
- With a classmate or instructor, review the details of the requirements discovery process
- Submit a one paragraph definition of requirements management.
- In collaboration with a 5-person team, create a solution-independent requirements document for the transportation requirements for package delivery driver.

Finally, lessons and activities were planned to accomplish the learning outcomes, verified by observation of the completion of the acceptable evidence. For example, in F2F lecture, approximately 30 minutes of lecture time was dedicated to describing relevant characteristics of requirements, which include:

- A requirement should state “what” is required, not “how” it is to be accomplished
- A requirement should be stated in such a way that it can be verifiable

- Each requirement should be “atomic” (requires exactly one thing)
- Requirements should use precise and grammatically correct language

To augment the lecture, two reading assignments were given to reinforce these core concepts and a 10-minute video clip was posted that emphasized Boeing’s requirement development during the 777 development program.

Following the student’s completion of learning assignments, they were presented with a list of intentionally flawed requirements statements and asked to identify the flaw and submit recommended improvements. These submissions were evaluated as acceptable evidence of achieving the original learning outcome: *evaluate requirements for adherence to relevant characteristics*.

The backward design process of identify desired results -> determine acceptable evidence -> plan learning activities was repeated for every topic and module in Aero 510. The output of this process is tightly-packed, efficient teaching plan with lecture, reading and support materials that support the learning objectives.

## **Discussion**

Ironically, this method of curriculum development follows an abstracted systems engineering process: clearly identify the requirements, and then plan all subsequent activities to verify the requirements will be met. Backward design establishes what an instructor wants to achieve (the requirements), determines the acceptable evidence to prove those requirements are met (verification) and directs the development activities accordingly (project planning). Further, many of us developing engineering curriculum, already do some or many of these activities either intuitively or by pulling from our experiences. This method of development may or may not deliver and effectively designed course. However, using the explicit, controlled backward design process, we are increasing the likelihood that our efforts will achieve the desired results.

### *Benefits Observed*

While I strongly feel that implementing backward design has improved my course and my teaching effectiveness overall, I have not attempted to quantitatively measure the improvements. This is, of course, a failure of a standardized continuous improvement effort (lack of technical performance metrics and a baseline of these metrics). However, I can use my own qualitative observations to communicate a few of the improvements I have seen:

- Students appreciate and respond positively to having explicit, well-defined requirements for assignments. If requirements are written as “what” and not “how”, then we as instructors can still challenge and require students to think and develop solutions.
- Students like options. Having asynchronous, online assignments, I can post a variety of materials and allow students to choose. While this makes guaranteeing exact consistency in assessment impossible, this has not yet become a problem.
- Students are engaged by differing content delivery methods. The technology allows for many differing methods to deliver content. For example, a short documentary video on Space Shuttle drop tests from a Boeing 747 to reinforce and illustrate verification testing methods is much more engaging than merely describing these tests with static photographs in lecture.



- Students like asynchronous assignments, both for the variety of the assignments and for the fact that they can work on and complete the assignments on their own schedules.

### *Lessons Learned*

The CTL provided excellent instruction and support in preparation for developing this course. However, there was much to learn not only with using the technology to create and manage the asynchronous activities, but also with delivering content and explaining the varied tasks to students. For most of the students, this was their first experience with a blended course. Mistakes and lessons have, of course, been learned along the way:

- **Technology issues:** It seems that no matter the amount of preparation, there will always be students that struggle with the technology. Sometimes it is the student's inexperience or unwillingness to try something new or it is simply some obscure detail that prevents the technology from working correctly. My lesson is to just accept that this is going to happen and deal with each case with as much patience and a willingness to provide "work-arounds" as possible.
- **Explicit communication of expectations:** Even with my understanding of proper requirements characteristics, I still missed sometimes. My lesson is to expect students to question a poorly written requirement and to plan on making modifications to it as errors are understood.
- **Anticipating varied student schedules and procrastination:** When students are working collaboratively on asynchronous activities, it doesn't work to have a single due date at the end. Some students perform work early and wait for the others to contribute. However, as I should have anticipated, some students wait until the last possible minute to begin the assignment. This leaves no time for there to be any real, iterative collaboration. My lesson is to have intermittent checks, which require all students to collaborate several times throughout the assignment.
- **Need for better assessment techniques:** It is difficult to get everything just right the first time. I feel some of my assessment methods are inappropriate for the assignment or just not well-enough developed. My lesson is to practice continuous improvement by identifying the trouble areas and working to slowly improve those areas by small iterations.
- **Time commitment to develop a blended course:** Finally, it is often stated in the literature and by my colleagues at the CTL: it takes a lot of time to redevelop a course using backward design and blended course concepts and technology. My lesson is to listen to their estimate, then double it.

### **Conclusion**

The development of a blended course requires not only a mastery of the related technology, but also a fundamental understanding of curriculum design. Perceptions of a blended course may be that it is simply moves the delivery of course content online. We have likely all witnessed examples of poorly implemented use of technology and realize that, in fact, not all teaching-related technology is useful. However, if properly designed, implemented and delivered using an established method such as backward design, the use of technology can improve the effectiveness of our teaching, even if the improvements are qualitative in nature.

Backward design was applied to the redevelopment of an introduction to systems engineering course. This first iteration was successful from a qualitative standpoint, but this is not the end of

the effort. The course deficiencies identified will be addressed and corrected. This paper is merely a status report of ongoing efforts that will continue as long as this course is taught.

## References

- Blanchard, B.S. & Fabricky W.J. (1990), *Systems engineering and Analysis*, Prentice-Hall International.
- Boyle, Tom. (2005) A Dynamic, Systematic Method for Developing Blended Learning. *Education, Communication & Information*, Vol. 5, No. 3, November.
- Cal Poly, Center for Teaching and Learning (<http://ctl.calpoly.edu/about/index.html>), accessed 20 February 2009.
- Department of Defense ( 2001). *Systems Engineering Fundamentals*. Defense Acquisition University Press, Fort Belvoir, Virginia.
- Driscoll, M. (2002) Blended learning: let's get beyond the hype. *LTI Magazine*, March.
- Lindsay, Elizabeth Blakesley ([http://www.accessmylibrary.com/coms2/summary\\_0286-19027188\\_ITM](http://www.accessmylibrary.com/coms2/summary_0286-19027188_ITM) ), accessed 20 February 2009.
- McTighe, J. & Wiggins, G. (2005). *Understanding by Design*. Expanded 2nd ed. Association for Supervision and Curriculum Development.
- Whitelock, D. and Jelfs, A. (2003). Editorial for Special issue on Blended Learning: blending the issues and concerns of staff and students. *Journal of Educational Media, Special Edition on Blended Learning*, 28(2-3), pp. 99-100.

## Biographical Information

Dr. Kurt Colvin joined the faculty at Cal Poly in 2000 and is currently an Associate Professor in the Department of Industrial and Manufacturing Engineering. He received a Ph.D. in Industrial Engineering from Oregon State University. Prior to Cal Poly, Dr. Colvin had 5 years of systems engineering experience and 5 years of research and collaboration with NASA Ames Research Center. He is a registered Professional Engineer in California. Dr. Colvin's major research interests include systems engineering methods and education, aviation human-factors and manufacturing technologies. His recent projects include building an experimental airplane with Cal Poly students, studies of pilots' visual scanning performance, and development of distance education-based systems engineering graduate courses. He is also an avid commercial-rated pilot.

## **Laboratory Projects Appropriate for Non-Engineers and Freshman Engineering Students**

**Kate Disney**, Mission College  
Engineering Faculty

**John Krupczak**, Hope College  
Professor of Engineering

### **Introduction**

The engineering departments at Hope College and Mission College both offer technological literacy courses targeted to non-science majoring students. These lab-based general education courses are designed with mechanical dissection and “make-and-take” lab projects that represent core technology.

These technological literacy courses are often referred to as “*How Stuff Works*” classes, because the focus is how and why core technology works as it does. Students are exposed to the scientific principles underlying the technology, and with this the students build or modify devices to work in a manner that satisfies a human desire, which is the engineering component.

Lab projects are constructed primarily with common, ordinary parts typically found in local retail stores. The use of simple parts helps to reduce abstraction and clarifies the underlying science of the technology. Engineering is explained primarily with natural language, demonstrations, teacher modeling, and hands-on lab projects. The lab projects either require students to take apart a device and analyze the functional parts (mechanical dissection) or build from scratch a new device (i.e. “make-and-take” projects).

Core Technology is defined as technology that is familiar to students as users. Core Technology is also technology that appears repeatedly in many engineered systems. Examples of Core Technologies are 1) a speaker, 2) a radio, 3) the LED, 4) the transistor, 4) the lever, 5) the internal combustion engine, 6) a DC motor, etc. These technologies are so familiar in everyday systems that students have a starting point from which to build their knowledge.

All people can and should understand the workings of common core technologies and have a basic understanding of the underlying science. With a “How Stuff Works” class, students are given a foundation that can be applied later to learning about other technologies not covered in the course. The benefits to having a technological foundation are clear – many important issues of our time have a technological component. With a proficient understanding of current technological issues, citizens could be more participatory and effective members of society.

Much work has been done through NSF funding to bring engineering, science, and technology to the public, but teacher materials for the college level are primarily available in electronic form. Support for faculty needs to extend beyond electronic file sharing to include supplying ‘starter’ kits that contain all the parts needed for students to build a project.

The Hope College – Mission College collaboration, with support from the National Science Foundation, is providing kits to faculty at other institutions and assessing if putting equipment and materials into hands of teachers is an effective means of getting more lab projects adopted into technological literacy and freshman engineering courses.

### **Why is Technological literacy important?**

The National Academy of Engineering (NAE), as stated in *Technically Speaking*, describes “Tech Lit” as

Technological literacy encompasses three interdependent dimensions – knowledge, ways of thinking and acting, and capabilities.<sup>1</sup>

Technology or the human-built environment is seen as encompassing four main content areas: Technology and Society, Design, Products and Systems, and Core Concepts and Connections.<sup>2</sup>

“How Stuff Works” classes falls into the *Core Concepts* category. The wide coverage of fundamental technologies makes these courses a starting point for college students who wish to have a better understanding of the broader technological world.

The NAE goes further to set the following goal:

The goal of Technological literacy is to provide people with the tools to participate intelligently in the world around them.<sup>1</sup>

Technology has become more widespread and essential in our society now than ever in the past, and yet most people have a poor understanding of the technology they interact with. Devices are smaller and unserviceable, interfaces simplify and hide the technology so that users do not need to understand the technology in order to use it, and much of new technology today is happening at the microscopic level. All of these facts add separation between the end-user and the technology. The result is that collectively citizens are becoming less aware of technology but at the same time more dependent on it. This chasm between dependence and understanding needs to be addressed.

The NAE makes a strong case for greater public understanding of technology in *Technically Speaking* by stating

Democratic principles imply that decisions affecting many people or the entire society should be made with as much public involvement as possible. As people gain confidence in their ability to ask questions and think critically about technological developments, they are likely to participate more in making decisions.<sup>1</sup>

The importance of an informed public on the health of the republic was stated numerous times by Thomas Jefferson. Jefferson was quoted as saying,

“If a nation expects to be ignorant and free in a state of civilization, it expects what never was and never will be.”

Technological literacy should be as important to our students as cultural literacy. A foundation of technological literacy not only helps explain the workings of technology but illustrates how fully integrated technology is into the fabric of society.

Technological literacy courses can serve as an educational bridge between the liberal arts and engineering. Samuel Florman<sup>3</sup> called for educational bridges to provide a route for engineers to access the arts. In the case of technological literacy courses, they are the bridge that gives the non-science student access to engineering and technology.

### **Types of Technological Literacy courses**

Engineering departments on a number of campuses have begun to offer technological literacy courses for non-science majoring students<sup>4</sup>. There are four standard models of technological literacy courses as explained by John Krupczak and Dave Ollis:<sup>5</sup>

1. The Technology Survey course.
2. The Technology Focus Course that focuses on a particular technology area.
3. The Technology Creation Course (a course with design emphasis).
4. The Technology Course that Critiques, Assesses, Reflects, and/or Connects

Hope College and Mission College both offer Type-1, the Technology Survey Course designed for non-science majors.

## Course Format and Lab Projects

Our Type-1 survey courses have two interconnected parts when covering new core technologies:

First, there is a lecture designed around small learning increments<sup>6</sup> about the science and technology specific to what students will build and see in the lab project. This is done so that students have a basic understanding of how and why the technology works before doing the lab. This is done through lecture and demonstrations.

Second, the students dissect or build a device. In doing this the students reinforce lecture information through observation and experimentation. Lab questions are designed to require students to experiment with the device by doing simple tests during the lab. After seeing something work, most students are more internally motivated to explain on their own the workings of the technology.

Direct instruction and lab parts must connect together. Connections can be made by reviewing a second time the lecture material during and after the lab.

The risk of not connecting lecture with lab is two-fold. Without direct instruction from the instructor, students will robotically assemble a device (i.e. this becomes the “cook-book” lab that has limited impact). Without the laboratory component the lecture runs the risk of being one-way and flat, and student learning becomes overly passive. Ensuring that lecture and lab fit together throughout the course gives students the connections linking the science to the technology.

Some of the labs being used in the Hope College and Mission College courses are:

	Dissection Lab Projects	Core Technology	Related Science
1.	Toy Car with Internal Flywheel	Energy Storage using Flywheel; Cams; Mechanical Advantage using Gear Reduction Box	Kinetic Energy; Rotational Inertia; Work; Friction; Torque
2.	Mechanical Alarm Clock	Escapement; Energy Storage using a Spring; Hair Spring and Balance; Gears; Portable Time Pieces	Periodic Motion; Spring Potential Energy; Frequency, Sound; Pendulum (comparison)
3.	Four Cylinder Internal Combustion Engine	Pistons; Valves; Crank Shaft; Cam Shaft; Timing Belt; Fuel Injection; Bearings; Engine Head and Block; Seals & Gaskets	Thermodynamics; Linear to Rotary Motion; Friction; Combustion; Efficiency
	“Make-and-Take” Lab Projects	Core Technology	Related Science
4.	Speaker	Speaker; Voice Coil; Diaphragm; Permanent Magnet	Electricity & Magnetism; Electromagnet; Sound Waves; Vibration
5.	DC Motor	Electric Motor; Rotor and Armature; Commutator; Brushes; Power Supply	Energy Conversion; Conductors & Insulators; Generators (comparison); Torque; RPM
6.	AM Radio	Radio; Antenna; Diode; Modulation methods; Tuner Circuits; Filters; Carrier Waves; Uses of the Electromagnetic Spectrum	Electromagnetic Waves; Electromagnetic Induction
7.	Audio Amplifier Circuit	Transistor	Semiconductors
8.	Battery Recharging Unit using Solar Cells	Photovoltaic Solar Cells; Batteries; Designs for Efficiency	Energy Capacity; Power; Voltaic Cell; Series and Parallel Circuits
9.	LED Book Light	Light Emitting Diode; Switches; Incandescent Bulb (comparison)	White Light vs. Colored Light; Electricity; Energy Conversion; Ohm’s Law

**Table 1**

There are many other labs that would be appropriate for a Type-1 survey course. We chose those projects in Table 1 with the following goals in mind:

- a) For items used in dissection, it is important to choose devices that will allow students to do functional decomposition. By taking the device apart the students can see the role of each sub-part and how it interacts with the other components. Functional Analysis helps students to transfer their understanding to other devices that utilize similar elements or core technologies.
- b) Labs should be done individually. Each student constructs his/her own device. Although students are encouraged to help each other, individual projects usually means that all students are taking ownership in the project, especially if the lab project is something students will take home and keep.
- c) Labs should require some manual work because learning and retention is enhanced when students do something with their hands.
- d) Labs should be as simple as possible while still including all the fundamental components of a working device.
- e) Create labs using simple, ordinary parts. Avoid using parts that are specially manufactured for a specific application as this will lead to a level of abstraction that is not necessary and may confuse some students.
- f) Find labs that represent core technology – building block devices that are used repeatedly in other systems. Projects should be either real devices used for dissection or if it is a “make-and-take” project the device constructed should do something useful. Projects should not just verify a scientific theory.
- g) Choose labs that can be connected together, either conceptually or literally. The speaker, radio, and audio amplifier are connected together so that students take away a complete AM radio.
- h) Choose lab projects that can be analyzed and described mainly with natural language (i.e. minimal math).
- i) Simplify labs and the directions such that every student who tries can complete the lab during the allotted time.
- j) Use inexpensive parts.



## Some Barriers to Offering Technological Literacy Labs

Aside from possible state level or institutional resistance to engineering as general education, there are other real barriers that may increase the effort of starting up a lab-based technological literacy course.

Budget constraints may limit lab projects. The semester cost for our technological literacy courses is approximately \$55 per student. Currently there are only a few appropriate texts and even fewer lab manuals designed for a Type-1 technological literacy course. Due to the lack of instructional materials, faculty must develop their own labs and lectures. Lab development may be burdensome because:

- a) Some trial and error is needed to fine tune lab projects and make labs affordable.
- b) In order to achieve a breadth of labs covering a wide range of engineering, faculty must develop labs outside their discipline area.
- c) Time may be limited because of heavy teaching loads, especially at small colleges.
- d) It takes time to identify reliable parts vendors, such that a successful lab can be sustained.
- e) Lab preparation is more intensive because of the individualized make-and-take model which demands more purchasing and organization. The lab technician may resist taking on different duties that do not fit the paradigm of existing science labs.

No one barrier is insurmountable, yet most faculty will encounter some aggregate of these barriers making course development challenging.

Despite the obstacles, the rewards for offering a technological survey course are great. By doing something challenging (i.e. coming up with good labs), we offer our students a valuable course with a significant added value that is hard to replicate outside our networks. The experience of constructing a working device such as a radio, or hands-on contact with an actual car engine, provides students with an understanding of technology that cannot be replicated by clicking through an online virtual laboratory simulation. Doing this ultimately should give our students a competitive advantage in the global marketplace.

The Hope College – Mission College collaboration is investigating the viability of sharing lab materials in order to make it easier for faculty to start up technological literacy courses or to introduce these labs into their existing freshman engineering courses.

## Lab Sharing

The internet has made materials in electronic format very easy to share. Lab equipment and lab projects cannot be shared in the same way. In order to adopt a lab, the teacher must acquire the materials and equipment, work through the project, and scale the lab to work in a setting of approximately 30 students. Often the “devil is in the details” and the devil is not seen until the lab project is sitting in the hands of the teacher. For this very reason equipment vendors set-up and demonstrate their products at trade shows or conventions. Pictures and videos do not “sell” equipment to consumers nor do they to teachers.

Recognizing this commits us to finding processes that will put materials and equipment into the hands of teachers.

The Hope College – Mission College collaboration is investigating the viability of sharing lab materials using our common shipping infrastructure, such as the US Postal Service and UPS. A sharing arrangement between colleges may be either on-going or temporary until new faculty become familiar enough with a lab project to prep the lab on their own.

We recognize that some labs are not cost-effective to share on an on-going basis (e.g. sharing a car engine). In such cases a one time share arrangement can be just enough to train the faculty and break the barrier of unknown. Having the actual equipment and using it in a lab setting gives faculty the “gestalt” needed to see the value of the lab. Having the lab equipment once also allows the faculty to better assess what is entailed in acquiring the lab equipment.

Hope College and Mission College have provided student kits for the following courses:

Computers, Networks, & Emerging Technologies: CNET 114 –  
“How Technology Works” at Ohlone College, Fremont, CA

Engineering: ENGR 10 –  
“Introduction to Engineering” at Las Positas College, Livermore, CA

General Engineering: ENGR 10 –  
“Introduction to Engineering” at San Jose State University, San Jose, CA

Engineering: ENGR 5 –  
“Engineering as a Profession” at Cabrillo College, Soquel, CA

Engineering: ENGR 01 –  
“Introduction to Engineering” at Ventura College, Ventura, CA

Our lab sharing efforts have mostly focused on courses designed for freshman engineering students. This is because most community colleges do not yet have a technological literacy course. Our labs can be used in an introductory engineering course but probably these courses would not offer all of the labs.

As faculty build up a set of introductory core technology labs, the effort of starting up a new technological literacy course should be much less daunting. It is our hope that faculty who do not currently have a technological literacy course will consider creating one and folding these labs into such a course. Our labs at the very least can serve as a baseline from which to develop a technological literacy survey course.

### **Other Benefits to Lab Sharing**

Every instructor has an area of expertise and yet the demand for understanding a wide range of technologies is great, especially in small engineering departments. Sharing labs puts into faculty's hands a lab they might otherwise never create themselves. This clearly can be seen as faculty development.

There is value in having someone (other than the person who created the lab) test a lab. The feedback allows for lab refinement. As labs are improved upon it is more likely that a set of canonical engineering labs will emerge. A refined set of labs is needed to validate the concept of technological literacy as general education, as well as to ease the efforts required for developing such courses. These labs could then be packaged into lab manuals and begin to help set a standard for technological literacy courses. A well developed repository of course materials is needed for a systemic shift towards accepting technological literacy as general education.

One of the most effective means of assisting faculty with new labs is to actually go and facilitate the lab with the faculty member. Although often infeasible, it is highly worthwhile as this real-time interaction helps build community among engineering faculty.

Lab sharing in no way should be one way. Faculty need to openly share their "secrets" – such as labs, teaching techniques, course materials, etc. if engineering is to mature into a discipline with a well defined role within general education. In order to identify and refine what it is we think all students should know, there needs to be some collective action so that our efforts take root and course materials represent what most faculty think are essential for technological literacy.

### **Conclusion**

It is important that we consider strategies to make it easier for engineering faculty to teach technological literacy to non-science majoring students.

A first step in addressing the barriers to offering technological literacy lab-based courses is for faculty who teach these courses to share their lab materials.

Information and lecture content in electronic format is now easy to come by, yet a lecture-only course makes for "flat" curriculum that can exist anywhere. In order to give an added value to our students, we must do the more difficult task of providing an enriched, hands-on lab experience.

As more hands-on labs for technological literacy courses are used and made available, we should see a canonical set of lab projects emerge. With wide spread adoption of labs there is an economics of scale that makes supplying lab materials cost effective for equipment manufacturers. So what is a lot of work today (prepping labs and assembling kits for students) should be significantly less work later as the technological literacy concept takes root.

Non-science majoring students need access to “How Stuff Works” courses in order to gain a foundation in the workings of technology. If students are offered technological literacy courses we will be giving them an opportunity to acquire knowledge of fundamental science and core technologies. With this basic understanding one can continue to investigate the workings of the modern world, thus producing a greater sense of empowerment and comfort with technology.

### **Acknowledgement**

This work was supported by the National Science Foundation, Division of Undergraduate Education under award: DUE-0633277. Any opinions, findings, and conclusions or recommendations expressed in this material are those of the authors and do not necessarily reflect the views of the National Science Foundation.

### **References**

1. National Academy of Engineering, *Technically Speaking*, National Academy Press, Washington D.C., (2002).
2. *Tech Tally: Approaches to Assessing Technological Literacy*, Elsa Garmire and Greg Pearson, editors, National Academies Press, (2006).
3. S. Florman, *Engineering and the Liberal Arts*, McGraw-Hill, NY, 1968.
4. Krupczak, J.J., D. Ollis, “Technological Literacy and Engineering for Non-Engineers: Lessons from Successful Courses,” *Proceeding of the 2006 American Society for Engineering Education Annual Conference* (2006).
5. Krupczak, J. & D. Ollis, “Technology Courses for Undergraduates: Developing Standard Models”, *Proceedings of the 2008 American Society for Engineering Education Annual Conference* (2008). American Society for Engineering Education.
6. <<http://www.nifdi.org/>>

## **Multipoint Remote Temperature Monitoring and Data Acquisition System Using RF Technology**

Reza Raeisi, PhD  
and  
Mr. Deepak Anand  
Electrical and Computer Engineering Department  
California State University, Fresno

### **Abstract**

Embedded system and wireless technology has entered in all aspects of life with variety of useful functions. Wireless communication has changed the way data can be transferred and viewed across locations. Industrial wireless modems use electromagnetic waves to transmit modulated data typically using RS-232 standards. The focus of this work is the development of a “Multipoint Remote Temperature Monitoring and Radio Data Acquisition Embedded System” that is taking advantages from embedded microcontroller, such that interaction and processing with the wireless transceivers and the temperature sensors. The multipoint remote temperature monitoring radio data acquisition embedded system project is implemented using DS-18B20 digital thermometers that gives 12-bit resolution, long range 433Mhz HAC-UM96 with serial interface RF modems and the Freescale HCS12 microcontrollers. This hands-on project aims to use the mentioned hardware for remote data acquisition to monitor and collect temperature and report back wirelessly to be further processed by the embedded microcontroller. One RF modems is used to communicate with the rest of the RF modems and receives the temperature from the remote locations. Project is implemented by using the HCS12 Dragon 12 plus Development Board as embedded microcontroller and “Code Warrior”, an Integrated Development Environment (IDE) for embedded applications. The software is written in ‘C’ programming language using the Code Warrior IDE. The Code Warrior IDE has been developed by Freescale Semiconductor Company<sup>[1]</sup>.

### **Introduction**

Industrial wireless modem accepts serial data (typically using RS-232, RS-422, or RS-485 standards) and transmits it without wires to another device which receives and converts it. Data is sent from one end to the other as if there were a cable. Industrial wireless modems use electromagnetic waves to transmit modulated data. This is done using radio modems as access points. Radio modems are radio frequency transceivers for serial data. They transmit to and receive signals from another matching radio modem. Access points are various junctures in the network that enable wireless network connectivity. The systems that enable supervision of remote processes for data collection are normally termed remote data acquisition or remote data collection systems. These systems are designed using PCs and other processor-based input/output modules conforming to RS-232 and RS-485 standards. Multipoint Remote Temperature Monitoring can create accurate and real time reports in an environments where automated temperature monitoring system is required. Application examples of this kind of

device are in automated temperature monitoring in food industries and health care organizations that are extremely regulated when it comes to proper temperature control<sup>[2,3]</sup>.

### Project Problem Statement

The main focus of this work has been the development of a remote data acquisition system and embedded microcontroller application in order to enhance and promote experiential learning in undergraduate education for computer engineering students.

### System Architecture

“Multipoint remote temperature monitoring and data acquisition system using RF technology” is a project taking advantage of wireless technology and mobility of embedded system. It aims to monitor temperature at various zones and report back wirelessly the temperature of these zones to a master node. It is possible for the master node to monitor the temperatures of different zones for controlling purpose. The system architecture overview is shown in figure 1.

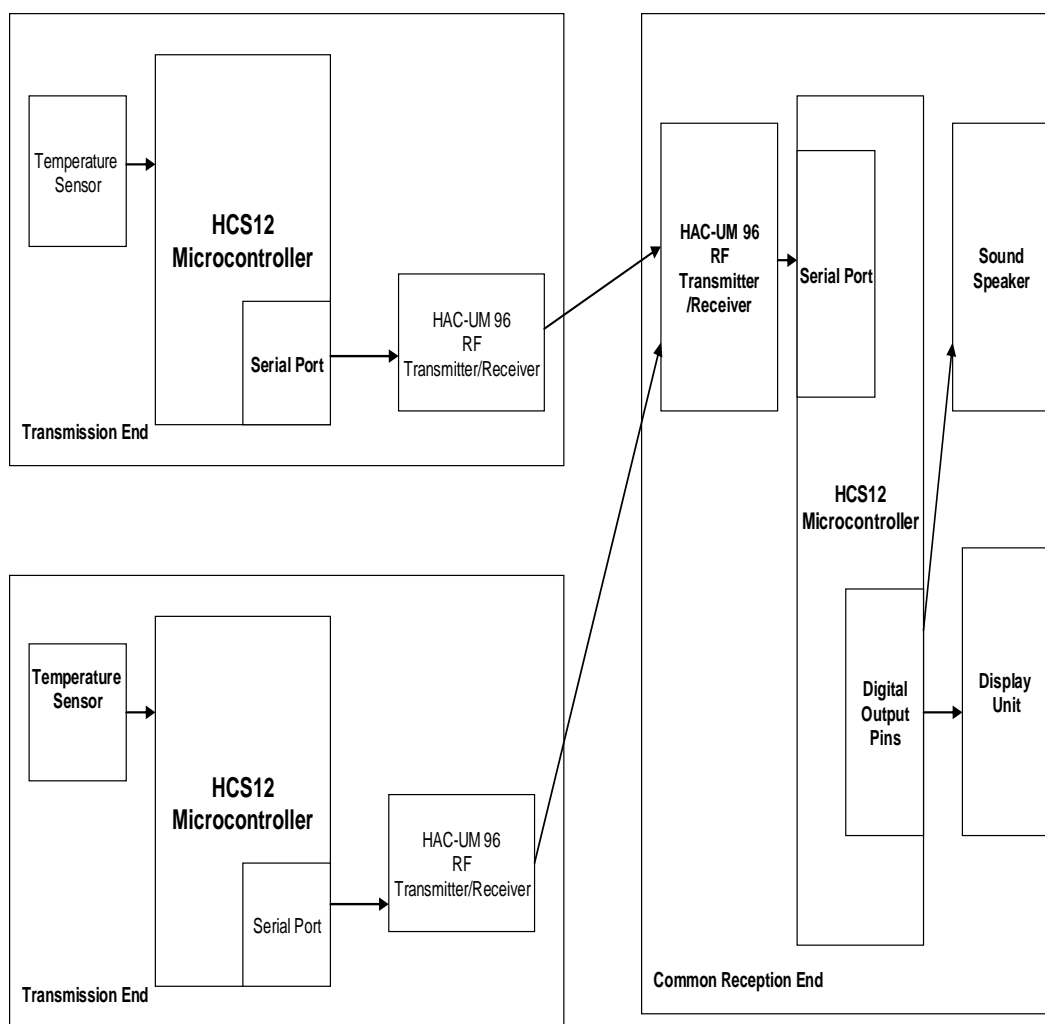


Figure 1 System Architecture

This Project takes advantages from embedded system, such that processing and interaction with the wireless transceivers and the various sensors can be integrated on small board that is easily installed in any place and start working once it takes the power.

In this project Dragon12-plus<sup>[4]</sup> trainer board is used to perform the following operations:

1. Reading the temperature sensor.
2. Use RS232 serial protocol to load temperature data to the wireless antenna.
3. Use RS232 serial protocol to unload temperature data from the wireless antenna.
4. Display the sent temperature on LCD screen and alerting with sound warning in case of emergency.

The Dragon12-Plus trainer is a low-cost, feature-packed training board from Freescale HCS12 microcontroller family. It incorporates many on-board peripherals that make this board very popular trainer for teaching microcontroller course in universities around the world.

### **RF Module (HAC-UM96)**

The HAC-UM96 is designed to be a low cost and high performance radio modem. It is a UART device; data is framed according to the UART standard, very simple to use and is shown in figure 2. HAC-UM96 has a long transmission distance of more than 300m in the visible range. It support dual serial port and 3 interfaces, with COM1 as TTL level UART interface and COM2 as user defined standard RS-232/RS-485 interface<sup>[5,6]</sup>.



Figure 2 HAC-UM96 RF Modems

### **Setting of channel, interface and data format**

Before using HAC-UM96 RF modem, the user needs to make simple configuration based on its own needs to determine the channel, interface mode and data format as shown in figure 3. There is one group of 5-bit short-circuit jumper wire (JP2) on the upper right corner of HAC-UM, defined as ABCDE respectively. Assuming the open circuit of jumper wire (without short circuited) is mode 1 and short circuit of jumper wire (with short circuited) is mode 0, then the configuration is as follows: ABC jumper wires of JP2 provide 8 options, and the user can choose to use 0-7 channels through ABC jumper wires. Within one small communication network, as long as ABC jumper wire mode is same, there can be mutual communication.

Channel No.	Frequency	Channel No	Frequency
CBA=000(0)	430.2000 MHz	CBA=100(4)	434.6940 MHz
CBA=001(1)	431.4288 MHz	CBA=101(5)	434.2332 MHz
CBA=010(2)	431.7360 MHz	CBA=110(6)	433.1580 MHz
CBA=011(3)	430.5072 MHz	CBA=111(7)	433.9260MHz

Figure 3 Corresponding frequency points of 0~7 channels

The frequency points corresponding to each channel can be adjusted based on the user's needs.

1=Unplugging short circuitry

0 =Plugging in circuitry

The HAC-UM96 pin description is shown in figure 4. The serial ports COM1 (Pin3 and Pin4 of JP1) is fixed as UART serial port of TTL level; COM2 (Pin6 and Pin7 of JP1) can choose non-standard RS232/485 interface mode through D of JP2:

D=1 (Unplugging short circuitry) COM2 = RS-485

D=0 (Plugging in short circuitry) COM2 = RS-232

HAC-UM96 can support no-parity or even parity modes of the serial communication UART, i.e. 8N1/8E1, which can be chosen through E of JP2:

E=1 (Unplugging short circuited) Parity: 8E1 (even parity)

Then the used configuration in the project is:

A = 1 B = 1 C = 1 D = 0 E = 0

PIN	SIGNAL NAME	FUNCTION
1	GND	Ground
2	VCC	Power supply DC
3	RxD/TTL	Serial data input to the transceiver
4	TxD/TTL	Transmitted data out of the transceiver
5	SGND	Signal
6	A(TxD)	TxD of RS-232
7	B(RxD)	RxD of RS-232
8	SLEEP	Sleep control (input)
9	RESET	Reset signal (input)

Figure 4 HAC UM96 Pin Descriptions

### Temperature Sensor (DS18B20)

The DS18B20 digital thermometer shown in figure 5 provides 9-bit to 12-bit Celsius temperature measurements. It communicates over a 1-wire bus that by definition requires one data line to



communicate with the HCS12 processor. Each DS18B20 has a unique 64-bit serial code, which allows multiple DS18B20s to function on the same one wire-1 data bus<sup>[7]</sup>.

The 1-Wire bus system uses a single bus master to control one or more slave devices. The DS18B20 is always a slave. When there is only one slave on the bus, the system is referred to as a “single-drop” system; the system is “multi drop” if there are multiple slaves on the bus. All data and commands are transmitted least significant bit first over the 1-Wire bus. 1-Wire bus system is broken down into three parts: hardware configuration, transaction sequence, and 1-Wire signaling (signal types and timing). Hardware Configuration can be defined as the 1-Wire bus has by definition only a single data line. Each device (master or slave) interfaces to the data line via an open-drain or 3-state port. This allows each device to “release” the data line when the device is not transmitting data so the bus is available for use by another device. Therefore, one master microprocessor can control many DS18B20s at different location. This feature is very useful in HVAC environmental temperature controls or any other temperature monitoring control systems<sup>2</sup>.

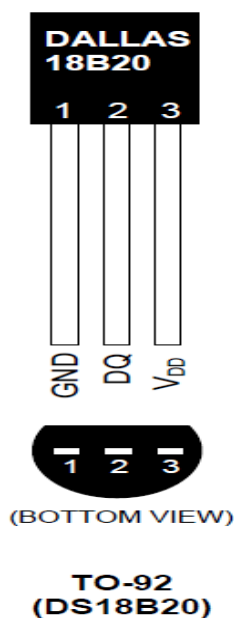


Figure 5 Temperature Sensor

The transaction sequence for accessing the DS18B20 is as follows:

Step1. Initialization

Step2. ROM Command (followed by any required data exchange)

Step3. DS18B20 Function Command (followed by any required data exchange)

It is very important to follow this sequence every time the DS18B20 is accessed, as the DS18B20 will not respond if any steps in the sequence are missing or out of order. Exceptions to this rule are the Search ROM [F0h] and Alarm Search [ECh] commands. After issuing either of these ROM commands, the master must return to Step 1 in the sequence.

All transactions on the 1-Wire bus begin with an initialization sequence. The initialization sequence consists of a reset pulse transmitted by the bus master followed by presence pulse(s) transmitted by the slave(s). The presence pulse lets the bus master know that slave devices (such as the DS18B20) are on the bus and are ready to operate.

### HAC-UM96 interface with HCS12

Proper connections need to be done as shown in figure 6 so that communication between master and slave board takes place. Two HCS12 boards are named as slave boards 1 and slave board 2 respectively. One HCS12 board is named as master board. The slave board will read the temperature and sent it to the master board wirelessly through the help of RF module.

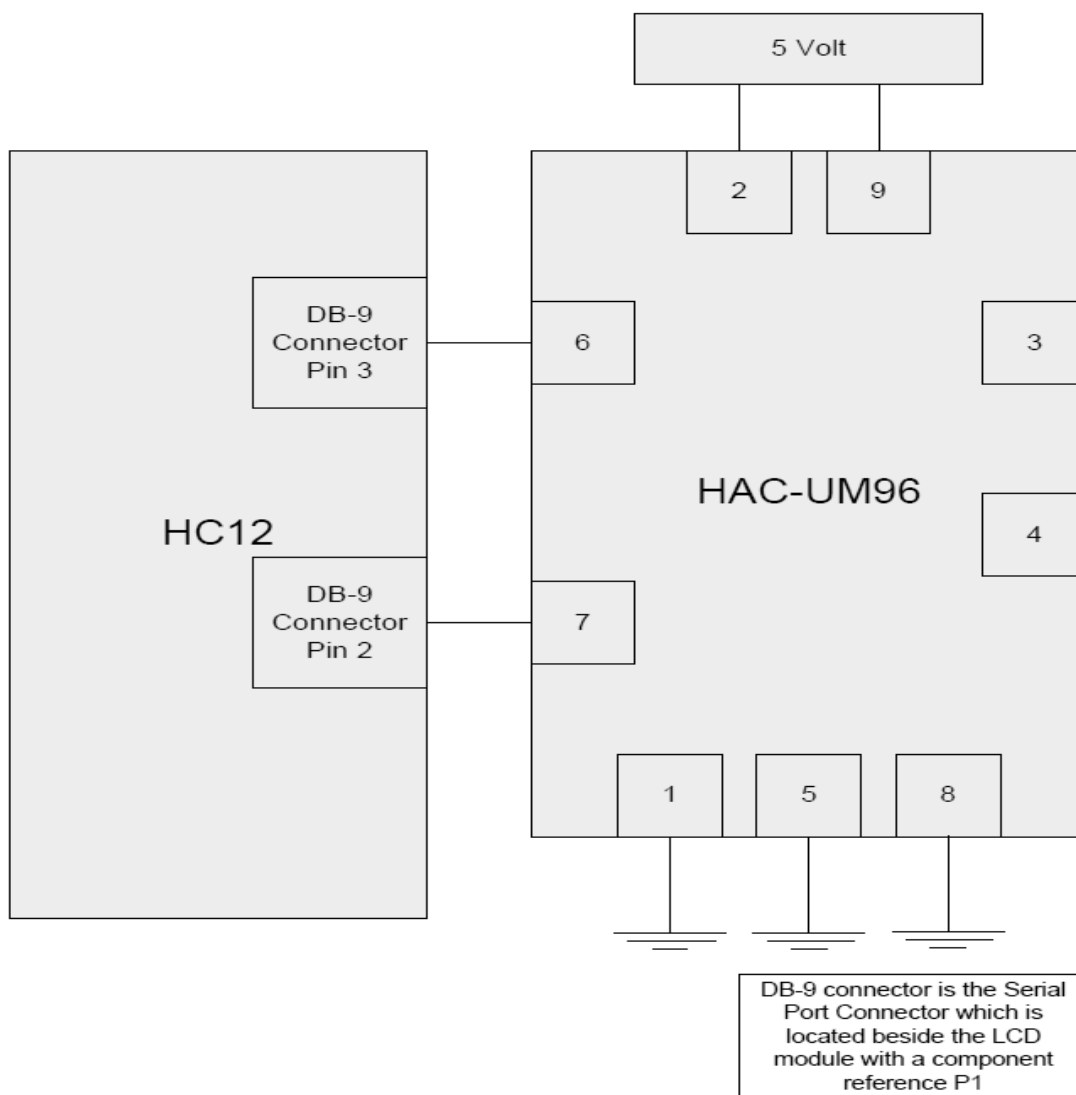


Figure 6 HAC-UM96 interface with HCS12

Pins 3 and 4 will not be connected to the HCS12 microcontroller and the connection remains open. Make sure Pins 1, 5 and 8 are properly grounded. Pin 6 and Pin 7 i.e. Transmitter and

Receiver of HAC-UM96 will be connected to the Receiver and Transmitter of HCS12 board respectively.

### Temperature Sensor interface with HCS12

Temperature sensor interface with HCS12 is shown in figure 7. Pin 1 of temperature sensor is properly grounded. Pin 2 i.e. Data Input/output pin is connected to PE4 of HCS12. Pin 3 is connected to voltage supply of 5v from HCS12 board.

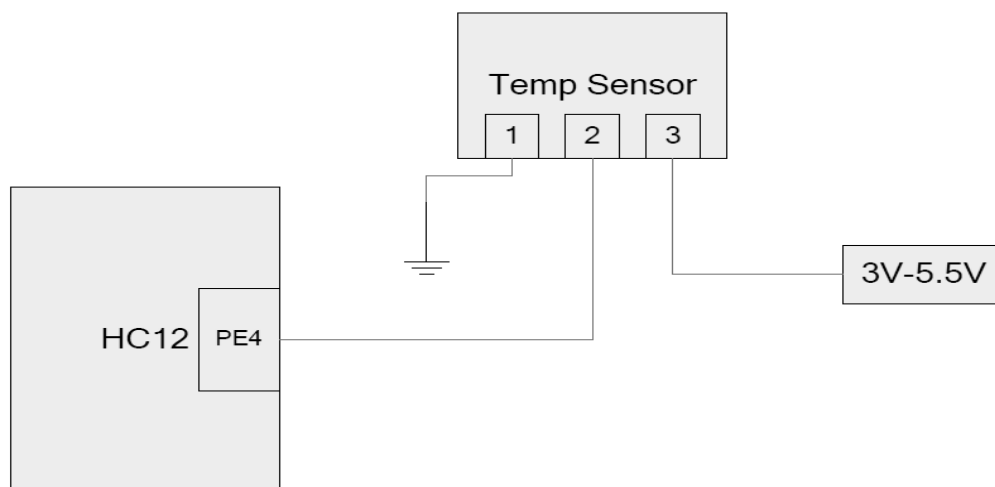


Figure 7 Temperature Sensor Interface

### Operation and Conclusions

In conclusion, when the board is powered on and a reset is pressed on the Slave Board 1, the temperature sensor connected to the HCS12 reads the room temperature. Similarly when the board is powered on and a reset is pressed on the Slave Board 2, the temperature sensor connected to the HCS12 reads the room temperature. Now the Master board is powered on and a reset is pressed. The UM-96 connected to the master board will try to make a contact with slave board 1 and 2 respectively requesting the HAC UM96 connected to the slave boards to transmit the data i.e. temperature to the master board. The master board will read the temperatures sent by both the boards and display it on the LCD of the microcontroller. If the temperature of the particular zone increases above certain defined range, an alert will be there through the help of a speaker. This project can be implemented with higher range of modem and expanding the current network of 2 zones to a network of several zones so that master board can read temperature from different locations.

### Bibliography

- [1] Code Warrior, Retrieved Summer 2008 from <http://www.freescale.com/webapp/sps/site/homepage.jsp?nodeId=012726>
- [2] Introduction to Communication System , Retrived fall 2008 from [http://www.teledesignsystems.com/data\\_collection.html](http://www.teledesignsystems.com/data_collection.html)
- [3] Applications of Wireless Temperature Sensors, Reterived Fall 2008 from <http://www.sensatronics.com>

- [4] Dragon12 plus hcs12 manual, Retrieved Fall 2008 from <http://www.evbplus.com/hcs12.html>
- [5] HAC-UM96 Datasheet1, Retrieved from [http://www.hactech.com/documents/HAC-UM\\_V2.pdf](http://www.hactech.com/documents/HAC-UM_V2.pdf)
- [6] HAC-UM96 Datasheet2, Retrieved Summer 2008 from [http://www.sparkfun.com/datasheets/RF/HAC-UM96\\_manual.pdf](http://www.sparkfun.com/datasheets/RF/HAC-UM96_manual.pdf)
- [7] Temperature Sensor DS18B20 Datasheet, Retrieved from <http://datasheets.maxim-ic.com/en/ds/DS18B20.pdf>

## **Biography**

### **Reza Raeisi, PhD**

Dr. Raeisi is an Associate Professor and graduate program coordinator in the Department of Electrical and Computer Engineering at California State University, Fresno. His research interests include Integrated Circuits, VLSI-CAD, and Embedded Systems Design. He is an experimentalist and enjoys hands-on working in the area of FPGA based digital design synthesis and system level modeling using HDL, and application of embedded microcontroller hardware and software as they related to education and laboratory environments.

### **Deepak Anand**

Mr. Deepak Anand received a Bachelor's degree in Electronics and Communication from Uttar Pradesh Technical University in India in 2006. He also received a Master's degree in Electrical Engineering from California State University Fresno in 2008. His research interests include nanotechnology, embedded system, and control Systems

## **Agile Problem Driven Teaching in Engineering, Science and Technology**

Pradip Peter Dey<sup>1</sup>, Thomas M. Gatton<sup>1</sup>, Mohammad N. Amin<sup>1</sup>,  
Mudasser F. Wyne<sup>1</sup>, Gordon W. Romney<sup>1</sup>, Alireza Farahani<sup>1</sup>, Arun Datta<sup>2</sup>,  
Hassan Badkoobei<sup>1</sup>, Ralph Belcher<sup>1</sup>, Ogun Tigli<sup>1</sup> and Albert P. Cruz<sup>1</sup>

<sup>1</sup>National University, 3678 Aero Court, San Diego, CA 92123, U.S.A.

<sup>2</sup> National University Community Research Institute, 11255 North Torrey Pines, La Jolla, CA 92037

### ABSTRACT:

In problem driven teaching, all major teaching activities are driven by a problem or a set of problems. Some typical problem solutions are demonstrated by the instructor. Problems could be based on realistic or abstract situations. Recent research suggests that abstract problems may have some advantages over others. This paper demonstrates how course learning outcomes are adequately handled in agile problem driven teaching in Engineering, Science and Technology courses for effective interactions.

Problem driven teaching is not the same as Problem Based Learning (PBL). In PBL, learners are usually organized into groups, and one or more problems are given to each group for solving the problems under the supervision of the instructors. Although PBL is highly successful in certain environments, it is not necessarily appropriate for all learners and all topics since the teaching methods may not be dynamically modified. Adjusting teaching methods based on learner feedback may be appropriate in multi-model, multi-strategy learning environments. Agility in teaching helps to overcome the different challenges faced by different learners for different topics. Our discussion of agile problem driven teaching considers all instructional strategies including lectures, transformations, experimentations, problem solving, analogical, case-based and mathematical reasoning for affective learning utilizing tools and technologies in an innovative way. An effective teacher takes complete responsibility for student learning and grade specification. Agile problem driven teaching may be the right approach for solving some of the most crucial problems in engineering education.

### 1. INTRODUCTION

According to the 2005 report of the National Academies, “Rising Above The Gathering Storm: Energizing and Employing America for a Brighter Economic Future,” the USA is losing its long-standing global lead in science, math and engineering education (The National Academies, 2005). “Recent test results show that U.S. 10th-graders ranked just 17<sup>th</sup> in science among peers from 30 nations, while in math they placed in the bottom five” (Wallis, 2008). There is enough indication that this educational trend is temporally coupled with a closely following severe economic downturn. Clearly, prolongation of this trend is a danger to the U.S. economy and the U.S. standard of living. We live in a rapidly changing world, with a global job market, global educational competition, a globally integrated economy, escalating energy problems, mounting trade imbalances and an unprecedented financial crisis. The new U.S. generation needs to have modern educational advantage in order to compete in the global job market and solve exigent

problems. Well educated engineers, technologists and scientists are in demand. In order to build a robust economy with sustainable growth, educated problem solvers are needed. However, schools and colleges are not succeeding in producing innovative problem solvers. Many different teaching strategies have been tried and show important improvements in student learning in various settings (Borman, 2005). However, significant nationwide improvements have not been achieved despite these isolated demonstrations of successful cases.

Problem Driven Teaching (PDT) is closely related to Problem-Based Learning (PBL) which is the educational process by which problem solving activities and instructor's guidance facilitate learning. PBL is a pathway by which students "learn how to learn". It challenges students to think critically, be pro-active, analyze problems, and find and use appropriate learning resources (Queens 2009). In PDT, all major teaching activities are driven by a problem or a set of problems. Some typical problem solutions are demonstrated by the instructor and students practice problem solving among other activities in order to master the learning outcomes. Problems could be realistic or abstract. Recent research suggests that abstract problems have some advantages over others (Kaminski, Sloutsky, Heckler, 2008). However, unlike PDL, an important aspect of PDT is that instructor plays an active role in teaching activities.

In a PBL environment, students are usually divided into teams to work on problems. In this model the problems are expected to drive the learning activities, a common practice in medical science, particularly in psychiatry (Adamowski, Frydecka, & Kiejna, 2007). In this strategy the instruction of the topic is organized around problem solving tasks. Some of these tasks are problem analysis followed by relevant information gathering; students may then try to identifying some possible solutions and provide pros and cons of each proposed solution. This strategy gives students abundant opportunities to think critically, communicate with their team members, present arguments as well as counter arguments, transfer knowledge to new situations, and develop creative problem solving skills. A key element of this approach is that all the problems are designed in such a way that students must gain new knowledge before they can solve the problem. Often, problems are complex and may not even be well defined. The new knowledge is acquired as students try to work through the problem. The role of the instructors in this environment is mainly as the facilitator and the guiding mentor. Students are given more responsibility for their own learning and are engaged in active or discovery learning in the sense that students discover and work with content that they determined to be necessary to solve the problem. It is believed that by working through the problems, students are better able to internalize the problem and understand the underlying concepts and fundamental relationships needed to solve the problem. In a traditional setting, instructors tend to simply provide students with facts, this is known as teacher-oriented instruction and many students may not be receptive to or grasp the new concepts. As a result they either tune out or never develop a deep understating of the materials and simply imitate mechanical operations and the essential analysis and arguments necessary to solve the problem. One common criticism of the PBL method is that students may not recognize what might be important for them to learn, so the facilitator must be extra careful to assess each student's prior knowledge. Another criticism is that instructors cannot cover as much material as the traditional method. Furthermore, the method is hard to implement and there are different definition and interpretation of the strategy and the manner of its implementation, within instruction, appears to be ad hoc. PBL requires a lot of planning and extensive work by the instructor.

In this paper we propose a new variation to PBL where the role of the instructor is more than being just a facilitator. We introduce the model of Agile Problem Driven Teaching (APDT) in which the instructor's role more closely approaches the traditional instructor approach. In APDT the instructor's presentation is more dynamic and can easily digress to cover a variety of "relevant" topics according to inquiries received from students. Similar to its PBL counterpart, the class is given a complex problem to solve. However, unlike PBL the role of the instructor in this approach is elevated to periodic coaching in order to accelerate the PBL strategy. In particular the instructor plays a key role contextualizing the problem and actively participating in the research, analysis, and information gathering component of PBL. The instructor becomes a facilitator once the initial body of knowledge to solve the problem is gathered. This gives students an opportunity to put together the final solution. In the APDT method the open problem along with student inquiries and the collective information gathering process derives the lecture, and this is where the agility in instruction becomes apparent and critical. The instructor must have extensive knowledge of the subject to efficiently process information and resolve student's questions and further suggest new directions for information gathering. In this method the new knowledge is shared among all teams in a form of a short presentation by the instructor. This provides the instructor with an opportunity to further clarify student misunderstandings and misinterpretation associated with the problem and the newly acquired information.

Use of technology can further simplify the APDT implementation and enhance student experience. In particular, in one scenario, students and the instructor each will have Tablet PCs with collaborative, interactive teaching tool such as Dyknow vision in a networked environment. In this, often wireless, networked environment, the Instructor's display is broadcasts to student's machines allowing students to synchronously follow instructor's lectures and add notes to the lecture with ink pen. The instructor can also permit students to lead class from their own machine. This connectivity clearly facilitates a powerful medium for students to collaborate and share as they search for new knowledge to solve the problem. Among useful features of Dyknow is the panel submission. Panel submission is most useful for APDT, because each team can, anonymously, submit their findings and request comments from the instructor. The instructor can quickly scan through all student submissions and select one or more panels to share with the rest of the class. It is through this sharing that the instructor can clarify misunderstandings, make additional comments or presentations, or provide new directions for search. The instructor can also opt to privately give comments to student submissions. Many educators have reported increase in student participation when Tablet PCs are used in the class. Panel submission and the follow up discussions often clarify many student misunderstands; the instructor can utilize the panel submissions to point out common errors and misinterpretations, or focus on the new knowledge reported by students to point out its relevance to the problem.

Adjusting teaching methods based on learner feedbacks may be appropriate in multi-cultural learning environments. Agility in teaching/learning and grading helps to overcome the different challenges faced by different learners for different topics. According to Glickman *"Effective teaching is not a set of generic practices, but instead is a set of context-driven decisions about teaching. Effective teachers do not use the same set of practices for every lesson . . . Instead, what effective teachers do is constantly reflect about their work, observe whether students are learning or not, and, then adjust their practice accordingly"* (Glickman 1991). Our ability to teach is enhanced with our agility to adjust. In education, the same size does not fit all. Agility is the

basis of APDT and consequently, it may combine a variety of teaching strategies. In addition to PBL, many other teaching and learning methods can be employed including the following: lecture (Cashing 1990); class discussion, brain storming (Instructional Methods, 2009); technology-based teaching learning (Kearsley & Shneiderman, 1999; Trondsen, 1998); game-based learning (Prensky, 2004; Van, 2008); experience based learning (Experience Based Learning Systems, 2008); inquiry-based learning (Eick & Reed, 2002; Educational Broadcasting Corporation, 2008); community-based learning (Owens & Wang, 2008); brain based learning (Brain Based Learning, 2008); work-based learning (Bailey 2003; Cunningham, Dawes & Bennett, 2004); project-based learning (Helic, Maurer, & Scerbakov, 2004; George Lucas Educational Foundation, 2008); team-based learning (Michaelsen, et al., 2008); web-based Learning (Lee & Baylor 2006; O'Neil & Perez 2006); and participatory learning (Barab, Hay, Barnett, & Squire, 2001). There is no conflict between these methods and APDT since it can adopt these methods if needed.

## 2. PROBLEM DRIVEN TEACHING IN MATH FOUNDATIONS (Main Author: P. Dey)

At National University, the APDT method was applied in a graduate course on mathematical foundations of computer science (National University course number CSC 610). Cohen (1997) was used as the textbook for this course. Lectures, class discussions, brain storming and quizzes were used regularly following the textbook. However, one main problem drove all these activities. In the first meeting for this course, each student was given a variant of the following problem.

Class-Problem: PART\_1. Build the most powerful computing machine that you can think of. Your machine should be able to process complex languages such as  $L_{11} = \{a^n d c^n d y^n : \text{where } n > 0\}$ . Demonstrate that a string like 'aadccdy' would be accepted by the machine. You need to build the machine by defining its elements mathematically. You are not required to deliver the machine with hardware components. If you do not use standard notations provided in the textbook or discussed in the class then you need to explain your notations.

It is known that Finite State Machines or Finite Automata can accept regular expressions. So, any string from the regular expression  $b^*aba^*b$  would be accepted by the following Non-deterministic Finite Automaton (Figure 1).

However, Non-deterministic Finite Automata cannot process a language like  $L_{11}$ , mentioned above, which requires a more powerful machine. You should be able to build such a machine. Explain how your machine will accept strings from  $L_{11}$ .



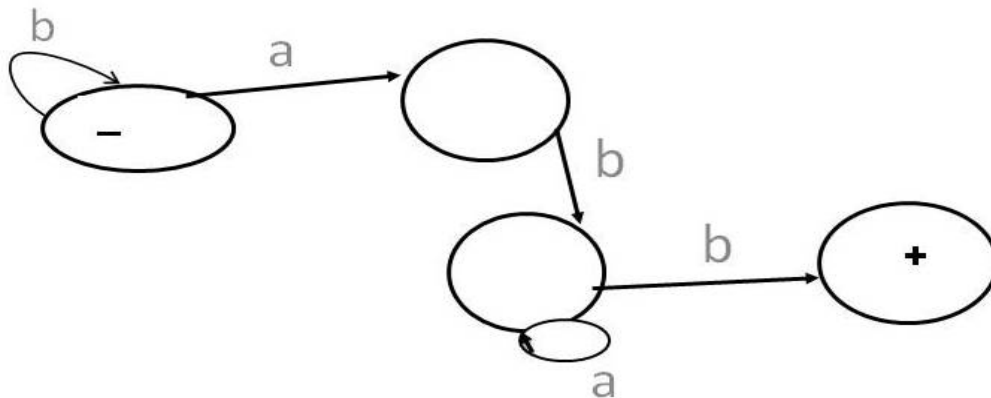


Figure 1. A Non-deterministic Finite Automaton for  $b^*aba^*b$

**PART\_2:** A Turing Machine has a finite set of states with one START state and some (may be none) HALT states. We always mark the START state with 1 and the HALT state with 2 (when there is only one HALT state).

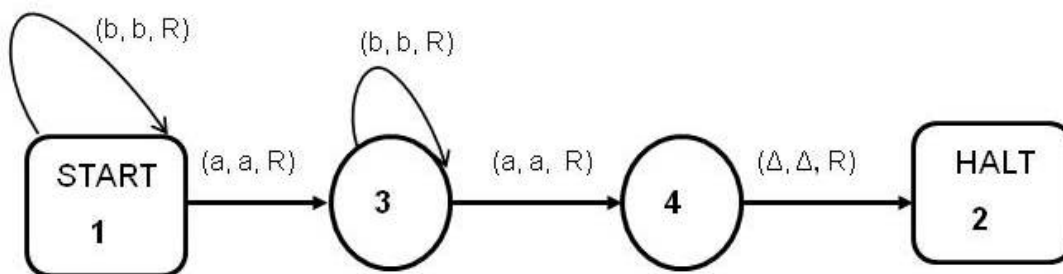


Figure 2. A Turing Machine for  $\{ b^*ab^*a \}$

The Turing Machine given above accepts the language:  $\{ b^*ab^*a \}$ . When an input is given it is processed by the transitions as the Turing Machine goes from state to state starting from the start state. The input is accepted by reaching the HALT state. If the HALT state and its incoming transition are destroyed then no input is accepted. The Turing Machine of Figure 2 would look like the machine given below after the destruction of the HALT state and its incoming transition.

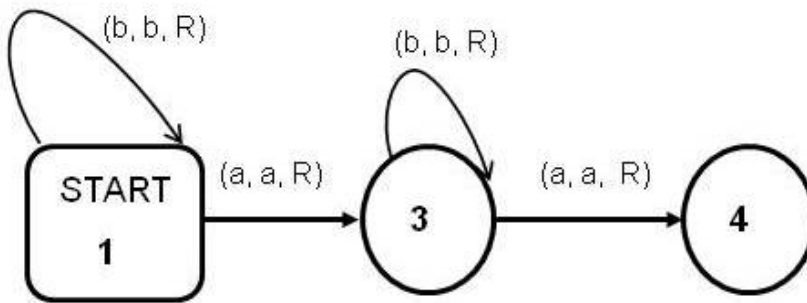


Figure 3. The Turing Machine of Figure 2 after the HALT state and its incoming transition are destroyed.

If the input is: aba, then the machine will start in the START state and reach state 4 after going through the loop of state 3. However, the input is not accepted.

You are asked to complete the following three tasks:

- 1) In the first step, destroy the HALT state(s) and their incoming transitions of your machine of the assigned problem (of PART\_1) and examine the consequences.
- 2) In the second step, destroy the START state and the associated transitions of your machine (in addition to the destructions mentioned in step 1) and examine the consequences.
- 3) In the third step, reconstruct the machine so that it is distinct from the original machine of PART\_1 (may have one or more additional states and/or transitions) and still process the same language (end of the Class-Problem).

The above problem was given out in the first meeting and the students started working on the problem and all teaching activities were related to this problem. Finite Automata, Pushdown Automata, Linear Bounded Automata, Turing Machines, Post Machines and the related sets accepted by these machines are taught with the goal of solving the above problem. The class started with the Finite Automata which could process regular expressions but would not be adequate for Context-Free languages. Pushdown Automata were then introduced in order to process Context-Free languages as well as regular expressions. The machines were built for dealing with increasingly complex sets. Finally, the problem was solved by building a Turing Machine for  $L_{11}$ . The students then experimented with breaking some parts of the machine and examining the consequences and then performing the repair work on the machine following the Part II of the problem. The teaching of the entire course was driven by a set of problems presented including the main problem mentioned above. Effectiveness of the teaching method was not measured scientifically although students evaluated the course according to the usual National University evaluation method which indicated significant improvements over earlier offerings of the same course.

The course learning outcomes for this course are given as follows. Upon successful completion of this course, students will be able to:

- \* Construct a model of computation for a given specification.
- \* Construct a Turing Machine for a given computational problem.
- \* Develop a program implementing the model of computation.
- \* Prove that regular expressions are equivalent to Finite State Machines.
- \* Prove that complement of a regular language is regular.
- \* Prove that a given language is Context-Free.
- \* Construct a Push Down Automaton for a given computational problem.

The first two learning outcomes are directly achieved through the class problem described above. Other learning outcomes are discussed when attempts are made to build machines of different types in the process of finding increasingly more powerful machines.

### 3. PROBLEM DRIVEN TEACHING IN DATABASES (Main Author: M. Wyne)

Various approaches to the teaching of computer science courses are currently under use and consideration. I (M. Wyne) have attempted a few teaching strategies that seem to make a difference in student understanding of the subject matter. To start with, I have revised my handouts to include not only the important materials for in-class discussion, but also to include study questions and practice problems in the handouts. The questions in the handout serve to challenge their thinking processes when it is time for them to study. They also help to generate more in-class discussion. Once in a while, I will discuss structure-activity relationships by asking students for their input instead of providing all of the facts for them. If a wrong answer is suggested, I usually follow up with another question to allow the students to see why it is not a good answer. I fully realize that by involving the students in lectures in this way, I may not be able to cover as much material as I would like, but I have never felt that I was not in control of my lectures. I have found that not only do the students learn database design better, but they have also come to enjoy the subject more, and have often come in to discuss their own experiences in database design with me on an informal basis. Furthermore, at the end of each major topic, I usually discuss one or two practice problems from previous exams, again with active participation from the students as a way to show them how to solve the problems. Additionally in my courses, I do encourage my students to come and discuss their solutions with me. In doing so, I am able to see their approach to learning and also which concepts are difficult for them to grasp. This allows me to think of different approaches to convey these concepts.

I have taught required introductory database design course to computer science students. I was interested in incorporating some of the PDT techniques. The PDT approach I use is a new concept in teaching of introductory Database courses. In this approach a problem is introduced and emphasized to students in order to make the study of database design more relevant to what student may experience in their practical life after graduation. For the past few years, what I came up with was a bit of “How to design a database for a company”. The requirements of the company database are also provided as the Company is organized into DEPARTMENTS. Each department has a name, number and an employee who manages the department. We keep track of the start date of the department manager. Each department controls a number of PROJECTS. Each project has a name, number and is located at a single location. For each EMPLOYEE’s we

store, Social security number, address, salary, sex, and birth-date, number of dependents. For each dependent, we keep track of their name, sex, birth-date, and relationship to employee. The number of hours per week that an employee currently works on each project is recorded.. The direct supervisor of each employee is also important. We also know that each employee works for one department but may work on several projects. These initial set of requirements gives students a good start and allow them to guess and work out other details.

The design of the problems that is used in PDT plays an important part in achieving the intended learning objectives set by the faculty teaching a course. To a large extent, the learning objectives set for the course determine their learning activities and form the framework for the direction of teaching methodology. I use the PDT approach to address four challenges: inadequate time to cover important material using only a traditional lecture format; enhance student motivation to study the material on a daily basis rather than just the night before an examination; increase student comprehension of the material, as well as increase student awareness of the level of comprehension required for satisfactory performance on examinations; and the necessity for the students to see the "whole picture" of the design before it is covered in class, as a mechanism for teaching students how to use logical thinking in learning the concepts presented in the course. During the first class with the students I present a problem, design a database for a company. Each lecture starts by introducing and reviewing the main concepts and steps required to develop an efficient database design. Design strategies commonly used are presented and the effects of any of the design features on their overall database design are discussed. The students are asked to recognize the effects of a specific design decision on the overall system operation. This is further emphasized by practical situations that are presented in the lecture. Consequently, they are expected to apply this information to a question on the examination. In this approach, I will ask several probing questions which are designed to stimulate the students' understanding regarding design decisions, and possible side effects.

#### 4. AGILE PROBLEM DRIVEN TEACHING IN INFORMATION TECHNOLOGY (IT) (Main Author: G. Romney)

##### 4.1 APDT in IT Focuses on Real-world Problems

Information Technology (IT) emphasizes synergistic solutions between technology, people and processes to successfully resolve enterprise computer problems. In the IT Management (ITM) program at National University, students learn that people, namely the client, drive the development process. IT professionals, with their knowledge, skills and set of technology tools attempt to meet the requirements specified by the client. In almost every development instance, the client's perception of the desired product evolves. The initial functional specification frequently defines a problem that may not have a solution as specified. Consequently, the engineering IT development team may have to redefine the problem in order to deliver a workable solution. In order to meet deadlines, frequently, the problem may be subdivided into modular components assigned to separate development teams. This is where APDT better prepares IT professionals to handle such common challenges encountered in the workplace.

Similarly to PBL, APDT as used in ITM focuses on real-world problems. Additionally, “agility” features are introduced to more closely simulate the real-world workplace that students will encounter. Agile components introduced are a) including multi-faceted problems that are subdivided into multiple team interaction and coordination, b) adjusting the defined problem to team-member skills, and c) allowing team-members to discover alternate solutions and “work-arounds” when barriers are encountered while discovering the solution to a problem. Redefinition of the problem in order to achieve a solution is frequently required in ITM. Introducing students to this realistic occurrence by employing the APDT method in their instruction better prepares them for the workplace.

Where PBL is based on a defined problem with usually one solution, APDT is based on the premise that agility, and creativity are required to redefine the problem in order to achieve a successful solution.

#### 4.2 Information Security Technology Course Problem – APDT Examples

A major course deliverable for ITM 475, a senior-level course in Information Security Technology, is an assigned problem that requires multiple team participation. This course teaches Information Assurance (IA) and the domains of the Certified Information Security System Professional (CISSP 2009). IA deals with protecting and defending information and information systems by “ensuring confidentiality, integrity, authentication, availability and non-repudiation” (Information Assurance 2009). The *Problem* objective given to the students, charged with assuming the role of IT security professionals, was to architect, design and implement components of a basic secure intranet.

The PDT approach implemented *experiential* hands-on assignments, presentations and projects that progressively contributed to the final solution. Consider the *Problem* to be a picture comprised of components or elements which are *mini-problems*. The *Problem*, then, is the sum and seamless integration of all the *mini-problems*.

The *mini-problems* identified by the students were the following:

1. Specification of the Local Area Network (LAN).
2. Specification of the hardware and software resources available for usage.
3. Demonstration of Wikis for class communication.
4. Demonstration of Blogs for class communication.
5. Evaluation of open source versus industry software for web portals and the selection of Microsoft’s Sharepoint for the WebPortal software.
6. Implementation of a prototype Sharepoint webportal that has, among its many features, Wiki and Blog capability.
7. Implementation of Microsoft IIS for Active Directory and Certification Authority functions needed for secure authentication as specified in the *Problem* objective.
8. Implementation of a VMware virtual environment.
9. Implementation of a Microsoft SQL Server.
10. Implementation of a MySQL database.

11. Implementation of a Ruby on Rails web development environment in order to meet the needs of the overall SOET Intranet by integrating the various *mini-problems*.
12. Implementation of a needed Linux test bed.
13. Implementation of a faculty research hard-disk repository.
14. Implementation of portable multi-factor authentication technology.

The *Problem* was divided into three distinct projects with three coordinated development teams using surplus servers and network switches on a gigabit communications pathway to the Internet as follows: 1) Architect the system to function virtualized under VMware, and integrate a virtual Rails environment, 2) Employ Microsoft (MS) SharePoint WSS services as the central node and interconnected via SQL script with both MS SQL Server and MySQL databases, and 3) Provide a certificate authority and implement a portable two-factor authentication process; and provide a Linux and implement a Time-date server for digital signatures. Part of the IA challenge of this defined problem was to architect the authentication process that would provide secure access for specific roles, such as administration, staff, faculty, adjunct faculty and students.

Each team created an initial Memorandum of Understanding (MOU), with the instructor acting as the client, regarding the scope, team organization, deliverables and delivery time-frame for each project. The delivery of the four projects and integrated *Problem* was scheduled four weeks from initiation. As work progressed, the discovery of seemingly insurmountable obstacles that threatened the success of the overall project heightened team frustration levels. The successful delivery of the intended solution of the *Problem* was in jeopardy. The concern by all was not only to deliver Project 1, 2 or 3, but the successful inter-operation of all three comprising the *Problem*.

Specific instances of where agile project management had to be employed, and, hence, where APDT was utilized were the following: 1) Team 3 had to reduce the scope of its project, 2) Team 2 encountered seemingly insurmountable obstacles, 3) Team 1 had to adjust to include the members of Team 3, and 4) all three teams had to adjust to on-going limitations and failure of the hardware.

#### 4.3 Team 3 Reduced the Scope of Its Project

Half-way through Project 3, a key team member was sent out of state by his employer. The Time-date stamp server feature assigned to this student could not be given to another. The Team re-negotiated with the client (the Instructor) and determined that this feature was not on the critical path for successful completion of the *Problem*. Hence, by agreement, and modification of its MOU this feature was deleted, the team combined with Team 1 and successfully completed the remainder of its tasks.

#### 4.4 Team 2 Encountered Seemingly Insurmountable Obstacles

The Team successfully installed .Net Framework 3.0 and SharePoint WSS 3.0 but emphasized that SharePoint could not execute SQL scripts even though it was based upon the MS SQL database. Likewise, there was no way to interface MS SQL or MySQL to SharePoint. The Team resigned itself to not be able to deliver the terms of the MOU and insisted that the client's

objective was not realizable with the specified product, MS WSS SharePoint. One member of the team, however, kept searching and discovered that SharePoint, by default, does not contain any database connections (SharePoint 2009). However, with another MS product, Office SharePoint Designer 2007, it was possible to access both MS SQL and MySQL databases, which the team successfully downloaded and demonstrated.

#### 4.5 Team 1 Adjusted to Include Members of Team 3

Refer to 4.3, above, for the circumstances that required a team management adjustment. This left two teams to successfully complete the *Problem* on schedule.

#### 4.6 All Teams Adjusted to Hardware Limitations and Failure

As frequently is the case in university (and industry) settings, computer hardware availability is limited and IT professionals implement whatever might be supplied. Servers were configured as functional components were identified but this did limit ambitions of the teams. All of this, again, required agile adjustment of plans.

The final result after four weeks, however, was delivery of an operational basic intranet with five servers and seven VMware virtual servers providing the required services. This could only have been achieved through APDT that taught the students how to accomplish what appeared to be “impossible” and to become better prepared for the reality of the real-world workplace.

### 5. PROBLEM DRIVEN TEACHING IN PROGRAMMING LANGUAGES (Main Author: O. Tigli)

As educators, our role is to facilitate students' learning. Of course, this is easier said than done. Unfortunately, learning doesn't happen overnight. We need to find creative ways for our students to increase their long-term of retention of knowledge. A well-known Chinese proverb states that: "Tell me and I forget; show me and I may remember; involve me and I will understand". The key here is the involvement of the students so that they will get the big picture, the fundamental idea that we are trying to convey as teachers.

In that sense, both "Problem Based Learning" and PDT bring the key involvement factor by introducing a problem to the students to solve.

However, these two approaches differ in their natural progress. While the first one promotes the direct student involvement throughout the process, the second one not only requires students' engagement with the issue in their hand but also promotes the educators to be a guiding figures, and major key players to monitor their students' progress. Definitely, both approaches have a certain place in education, and probably as educators, we utilize both techniques in our way of teaching.

In his inspirational 1988 paper, Stephen Wolfram mentions the fact that the essence of education is interaction, and this does not mean canned programs and canned classes. He emphasizes that the interaction will have to come from people since AI based computer programs are still far

away to communicate with people in a meaningful way. The human touch is still has the extreme importance in education.

In my programming languages classes, I (O. Tigli) try to take advantage of face-to-face communication by guiding students throughout the learning process, by covering fundamental topics and learning outcomes in each and every session. In these sessions, we go through little excursions in computer science, and try to grasp the concepts of lexical analysis, parsing, semantic analysis, and code generation by using initially small but growing examples. I also give them a short-term project to work on. Sometimes an alternative project requiring advanced programming skills is given as an option, as well. Besides all of these, I also try to maintain a simple supplemental web site to provide my students useful online materials including class notes and pointers to the other sites related with our topic. My observation is that this approach is working nicely and increasing the retention level for the students and creating good understanding of the topic on hand.

## 6. PERSPECTIVES ON AGILE PROBLEM DRIVEN TEACHING

Within the broad APDT framework multiple perspectives are encouraged. However, considerable emphasis is placed on agility in teaching strategies. Adaptation of a PDT approach to suit the learning levels and styles of the students is one of the essential concepts behind APDT. It must consider both the individual student as well as the combined characteristics of each team. Finding a successful teaching path that can benefit the full range of student competency levels is one of the most challenging obstacles in teaching. It is important to bring weak groups and/or individuals up to a suitable level of competency and allow enough flexibility for the advanced groups and/or individuals to continue in the development of more advanced competencies. This can be addressed by paying attention to needs of an individual student in a variety of ways including individual assignments or examination questions that offer “bonus” points. Typically, only advanced students will tackle this type of problem.

A combination of team and individual assignments can vary to promote the development of individual writing and problem solving skills. Simpler team assignments that insure group competencies in basic skills can efficiently develop these individual skills through active problem solving while also allowing the development of basic team skills. The level of problems assigned for team-based problem solving can be perceived by different groups of students as ranging from easy to difficult. This reflects the ranging level of skills possessed by the individual students. Individuals in each group may also reflect differing levels of knowledge. Should all the low level students be put together, or should each team have a distribution of students with basic, intermediate or advanced skills? Usually, students have some knowledge about each other’s skill levels and personalities and pick each other based on their personal preferences. Often, there is a tendency for the exceptional students to isolate themselves from the struggling students, thereby denying struggling students the benefit of their knowledge.

One of the most widely used and important Program Learning Outcomes (PLO’s) is that “The student will demonstrate a capability to work productively in a team environment.” Another



standard PLO is that “The student can demonstrate college level written and oral communication skills.” By integrating team solution presentation immediately after a problem-based session, students practice and develop these critical skills. In an extension of PDT, students are required to present their solutions to the rest of the class, after a problem solving session. This serves in the development of their presentation skills as well as their logical thought processes in problem solving. Some teams simply distribute the problems among the members and do little to develop team skills or benefit from problem-based learning. By requiring that the team’s solution presentation occur immediately after the problem-solving, and only assigning one problem during a problem solving session, teams are forced to work together on a single problem. Various levels of difficulty can be incorporated by giving each team a set of increasingly difficult problems and letting them pick which problem to solve. While this may allow a lazy, but advanced skill level, group to avoid solving a challenging problem, it is more likely that a team will desire to assert their superior problem solving skills to the class through their presentation.

Within a broad range of interpretations of APDT certain clear guidelines are evolving. The practitioners of APDT realize that certain propositions are more important than others:

1. Problems that match course learning outcomes are better than famous problems that poorly match the learning outcomes.
2. Analyzing feedbacks from students is more important than declaring student centered environments.
3. Dynamically adjusting teaching strategies to learner’s goals and preferences is more important than following a teaching plan.
4. Teaching activities are driven by realistic problem solving, feedbacks from students and learning outcomes rather than by a strict schedule or mandate.
5. Demonstrating problem solving strategies on sample problems is more effective for teaching/learning than lecturing on them.
6. Dynamically combining multiple strategies in multiple models is more effective for teaching/learning than relying on a single pre-planned strategy.

One of the authors (A. Datta) will be testing the APDT approach for teaching cyberinfrastructure (CI) to the biology students under CIBRED (CI-TEAM Implementation for Biological Researchers, Educators, and Developers), an NSF funded project. Teaching engineering concept to biologist and other non-engineering students is always challenging (Datta, et al., 2009). Nevertheless, the impact of CI in education is such that the Office of Cyberinfrastructure (OCI) at the National Science Foundation has established a rich source of educational and research materials through TeraGrid (TeraGrid, 2007) to meet the 21st Century's demand for scientific talent. Materials are freely available through CI/TeraGrid (Kay, et. al., 2008). Additionally, OCI put forth the CI-TEAM (Cyberinfrastructure Training, Education, Advancement, and Mentoring for Our 21st Century Workforce) program to aid education initiatives directed toward this new workforce. CIBRED is one of the funded collaborative projects (awarded to O. Crasta of VBI with A. Datta as a collaborator) of this OCI initiative. Courses are now being developed in a collaborative way using multidisciplinary approach integrating scientific and technology information from a variety of disciplines. The focus is to teach students from diverse disciplines for learning some essential concepts on computer technology in the context of application of cyberinfrastructure. These courses developed for K13 & K14 levels will be offered in an innovative classroom setting for hands-on experimental learning with a focus on solving a

scientific problem as a team. However, such an approach will be effective if the instructor follows the agile teaching technique to facilitate forming the students group working on a specific scientific problem.

## 7. CONCLUDING REMARKS: SETTING THE STAGE FOR EXPERIMENTAL STUDIES

Agility in teaching is generally advocated in several ways by many authors (Glickman, 1991; Dey et al., 2007) although it remains a challenge in practice for many teachers. Emerging tools and techniques would make it easier to deal with this challenge. Teachers need to perform their teaching with sufficient agility in order to adjust their strategies to problem solving environments and learner's goals, styles and preferences. The unique combination of PDT and agile teaching makes it resilient so that it thrives in a wide variety of environments. In order to measure the success of APDT it is necessary to conduct experimental studies in controlled environments. With deeper understanding of the issues, we are now better prepared for conducting our experimental studies on the effectiveness of our teaching methodology. Initial indications are that students as well as teachers benefit from APDT.

## References

- Adamowski, T., Frydecka, D. & Kiejna, A. (2007). "Problem based learning (PBL) – Possible adaptation in psychiatry". *Psychiatria Polska*, 41 (2), 163-169.
- Bailey, T. R. (2003). *Working knowledge: Work-based learning and education reform*. New York: RoutledgeFalmer.
- Barab, S. A., Hay, K. E., Barnett, M., & Squire, K. (2001). Constructing virtual worlds: Tracing the historical development of learner practices, *Cognition and Instruction*, 19(1), 47–94
- Barell, John (2006). *Problem-Based Learning: An Inquiry Approach*, Corwin Press, 2nd Edition.
- Brain Based Learning (2008) <http://eduscapes.com/tap/topic70.htm>
- Borman, K. M. (2005). *Meaningful urban education reform : confronting the learning crisis in mathematics and science*. Buffalo: State University of New York Press
- Cashing, W. E. (1990). Student ratings of teaching: Recommendations for use (IDEA Paper No. 22). Manhattan: Kansas State University, Center for Faculty Evaluation and Development.
- CISSP (2009). <http://www.isc2.org/>, 15 February 2009 23:15 UTC.
- Cohen, D. (1997) *Introduction to Computer Theory*, 2<sup>nd</sup> Edition, John Wiley & Sons, Inc., 1997.

Common Teaching Methods (1992)

<http://honolulu.hawaii.edu/intranet/committees/FacDevCom/guidebk/teachtip/comteach.htm>

Cunningham, I., Dawes, G., & Bennett, B. (2004). *The handbook of work-based learning*. Adershot: Gower Publishing.

Dey, P. P., Amin, M., Bright, M., Datta, A., Akhtar, S., Cruz, A., Wyne, M. F., Kennedy, P., Olson, P., Snyder, R., Farahani, A., Afuwape, S., & Badkoobehi, H. (2008). Multi-model multi-strategy teaching/learning in science, engineering and technology. *Proceedings of the International Computer Science and Technology Conference (ICSTC-2008)*, San Diego.

Datta, A., Caesar, J., Schuman, J., Cammer, S., Daphne Rainey, D., Crasta, O. (2009) CIBRED: Engineering Education on Cyberinfrastructure with a multidisciplinary approach for Non-Engineering Students, ASEE/PSW, March 19-20, San Diego

Duch, B. (2008). Problem-based learning. Retrieved February 10, 2008 from <http://www.udel.edu/pbl/>.

Educational Broadcasting Corporation.. (2008). Inquiry-based learning, Retrieved February 10, 2008 from <https://www.thirteen.org/edonline/concept2class/inquiry/inde.html>

Eick, C. J., & Reed, C. J. (2002). What makes an inquiry oriented science teacher? The influence of learning histories on student teacher role identity and practice. *Science Teacher Education*, 86, 401–416.

Experience Based Learning Systems (2008) Experience Based Learning, Retrieved December 4, 2009 from <http://www.learningfromexperience.com/>

Farahani, A. & Uhlig, R. (2009) Use of Tablet PCs to Generate Class Discussion and Facilitate Deeper Understanding, Submitted for publication.

George Lucas Educational Foundation, The. (2008). Project based learning, Retrieved February 10, 2008 from <http://www.edutopia.org/projectbasedlearning>

Glickman, C. (1991) Pretending not to know what we know, *Educational Leadership*, 48(8), 4-10, 1991.

Helic, D., Maurer, H., & Scerbakov, N. (2004). Knowledge transfer processes in a modern WBT system. *Journal of Network and Computer Applications*, 27(3), 163–190.

Information Assurance (2009). [http://en.wikipedia.org/wiki/Information\\_assurance](http://en.wikipedia.org/wiki/Information_assurance), 10 February 2009 05:06 UTC.

Instructional methods: Advantages and Disadvantages <http://www.adprima.com/teachmeth.htm>

Kaminski, J. A., Sloutsky, V. M., & Heckler, A. F. (2008) Learning Theory: The Advantage of Abstract Examples in Learning Math, *Science*, Vol. 320, 25 April 2008.

Kay Hunt, S. & Lathrop, S. (2008) Campus Champions – bringing HPC to your campus (2008). Panel discussion, Proceedings of the SC08, the International conference for high performance computing (HPC), networking, storage and analysis, Nov 15-21, Austin (TX)

- Kearsley, G. & Shneiderman, B. (1999) A framework for technology-based teaching and learning, Retrieved Dec. 11, 2008, <http://home.sprynet.com/~gkearsley/engage.htm>
- O'Neil, H. F., & Perez, R. S. (2006). *Web-based Learning: Theory, research, and practice*. Hillsdale, NJ: Erlbaum.
- Owens, T. R., & Wang, C. (2008). Community-based learning, Retrieved February 10, 2008 from <http://www.nwrel.org/scpd/sirs/10/t1008.html>
- Prensky, M. (2004). *Digital game-based learning*. New York: McGraw-Hill.
- Queens (2009). Good Practice, <http://www.queensu.ca/ctl/goodpractice/problem/index.html>, 11 February 2009 15:45 UTC.
- SharePoint (2009). <http://office.microsoft.com/en-us/sharepointdesigner/HA101009081033.aspx>, 14 February 2009 09:26 UTC.
- The National Academies (2005) *Rising Above The Gathering Storm: Energizing and Employing America for a Brighter Economic Future*, Retrieved on February 11, 2009 from: <http://commerce.senate.gov/pdf/augustine-031506.pdf>
- Trondsen, E. (1998). Technology-based learning, Retrieved February 10, 2008 from <http://www.sric-bi.com/LoD/summaries/LoDRpt01.shtml>
- Van, R. E. (2008). Game-based learning. *EDUCAUSE Review*, 41(2), 16–30.
- Wallis, C. (2008, February 25). How to make great teachers? *Time*, 171 (8).
- Wilson, J. (2007) Problem-Base Learning Revolution: Reformation or an empty promise? A review of the Constructivist Approach to Problem-Based Learning in Undergraduate Medical Education - Middlesex University Occasional Papers in Education & lifelong Learning, Vol. 1, No. 1, 2007, pp44-57.
- Young, L., K. Thearling, S. Skiena, A. Robison, S. Omohundro, B. Mel, and S. Wolfram, *Academic Computing 2* (1988) 8-12, 62-65.

## **Prerequisite Skills Testing as an Indicator of Student Retention**

David Lanning  
Embry-Riddle Aeronautical University, Prescott, Arizona

### **Abstract**

The results from a prerequisite skills exam, administered in a Solid Mechanics course in the sophomore year of the Aerospace and Mechanical Engineering degree curriculums, are evaluated as a possible identifier of at-risk students in an effort to increase student retention. The prerequisite skills exam was first implemented over two years ago in select engineering and math courses as a type of mastery exam, allowing students multiple attempts to pass the exam for credit towards their grade. This exam was largely created in an effort to boost student achievement in core engineering courses, but is also expected to be a useful self-assessment tool in anticipation of the next ABET visit. There are currently pressures to identify at-risk students and subsequently increase student retention through a variety of interventions, especially at a small, private university that is funded primarily through tuition dollars. Select results from the Solid Mechanics prerequisite skills exam are compared against a variety of factors, including drop-out rates, change of majors, and performance in both the Solid Mechanics and overall degree program performance. The study concludes that failure to pass the prerequisite skills exam can be a useful indicator for at-risk students.

### **Introduction**

The Aerospace and Mechanical Engineering undergraduate degree programs at Embry-Riddle Aeronautical University (ERAU) in Prescott, Arizona, are somewhat traditional four-year undergraduate engineering degree programs. The Prescott campus of ERAU may be categorized as a “teaching institution,” where the engineering faculty place emphasis on instructor-student interaction, design experiences, and hands-on laboratory learning.

Student retention is receiving increasing interest at Embry-Riddle, especially in recent months with the troubled economy. This is not a unique position for a small, private, tuition-driven university such as Embry-Riddle. Many such institutions are anxiously awaiting a full understanding of the effects of the economy on enrollments for the next academic year, which is viewed by many as quite uncertain due to both student difficulty in finding adequate student loan providers, as well as the possible inability of students to afford typically higher tuition and fees at private universities lacking state support. Since there is widespread recognition that enrollments may be at best flat in many engineering programs, and have been for quite some time, increasing retention is seen as one of the most viable methods for increasing total enrollment.

In fact, retention of students in engineering degree programs has received significant attention for quite a number of years. As an example, a search of the online ASEE Annual Conference Proceedings from 1996 to the present returned 180 papers with the word “retention” in the title, only a few titles of which were not referring to the topic of enrollment retention. As another example, in a 1997 paper Moller-Wong and Eide<sup>1</sup> cite Pascarella and Terenzini’s<sup>2</sup> claim that some 3000 studies on retention were conducted in the past 20 years (prior to the publication of this source, obviously). While some studies and writings have focused on minority retention<sup>3</sup> and general retention strategies<sup>4</sup>, much of this work has been focused specifically on the retention of freshmen<sup>5-12</sup>.

It has been long recognized that the freshman year is the most crucial opportunity for retaining students not only in a specific degree program (engineering in this case), but also in keeping students enrolled in higher education. Many programs enroll first-semester freshmen in an *Introduction to College and Degree Program*-style course, perhaps with a faculty member who may also serve as the students’ academic advisor<sup>6</sup>. A growing number of engineering programs enroll freshmen in a first-year design experience, with the aim of introducing students to the stimulating challenges of the design process early in their education, instead of only fundamentals courses such as calculus and physics and thereafter hoping they retain enough interest in engineering to continue towards typically more motivating courses in later years<sup>7,8</sup>. Efforts at improving freshmen retention through supportive advising have been reported<sup>9</sup>. And clearly, many programs coordinate all of these efforts and more into multi-pronged approaches in a significant and time-consuming endeavor to improve enrollments<sup>10-13</sup>.

The College of Engineering at the Prescott campus of Embry-Riddle has undertaken many such measures over the past years. A College Success course has long been a part of the freshman curriculum (optional for freshmen, although heavily recommended), the course content of which undergoes periodic review by the faculty to facilitate improvement. The College of Engineering Professional Advisor (who assists the students’ primary advisors, which are the degree program faculty) has been moved from a central campus advising facility to be co-located with the engineering faculty, and now works closely with all faculty members. Separate freshman design courses in different engineering disciplines were merged into a common-core freshman design course in 2004 to enable students to experience a wider range of engineering topics early in their education, with the aim of increasing student retention<sup>14</sup>.

The Prescott campus of Embry-Riddle has long had in place a week-six mid-semester deficiency reporting system. However, the reports don’t go out to the student and academic advisors until usually week seven or eight, and by the time the academic advisor gets the student into his or her office to discuss the deficiency, it may be well into week eight or nine of the fifteen-week semester, and perhaps too late to affect meaningful change for the student. As a supplement, the College of Arts and Sciences is developing and implementing an early-warning system, with some emphasis placed on freshmen retention. As the College of Engineering is considering similar options and alternatives, it is recognized that some emphasis should be placed on student retention at the sophomore level, which is the other significant block of students deemed to be at risk for changing majors or leaving school.

## Sophomore engineering

Embry-Riddle students refer to the typical second-semester sophomore schedule as “the gauntlet,” which includes courses in dynamics, solid mechanics, fluid mechanics, and differential equations. While Statics could be thought of as the first “real” engineering course where students solve the type of problems that appear in so many subsequent courses, many students are overwhelmed by the preponderance of such engineering problem solving during the semester following Statics. Some faculty view the “gauntlet” as one of the most critical semesters in an engineering student’s education, and students with weak study skills, lack of true interest in engineering, and poor preparation in fundamental courses often flounder in these courses for several semesters before eventually dropping out of the engineering program. Therefore, this semester is critical to student retention.

The author has taught the course in solid mechanics for eight (8) semesters at ERAU, which last included the Autumn 2008 semester. During this time, the author has found many students lacking in the necessary fundamental concepts from prior courses. The inadequate preservation of skills and knowledge from one semester to the next has been noticed by many instructors in the engineering degree programs at ERAU, although this is certainly not unique to our program or institution. In the case of Solid Mechanics, the most important prerequisite course is unquestionably Statics.

The author was approached several years ago by the Associate Dean of Academics at ERAU to help develop interest in prerequisite skills exams in a few courses on a trial basis, and the author took part in these trials. These prerequisite skills exams are based upon the ideas behind “mastery learning” methods<sup>15,16</sup>. Techniques based upon mastery learning include Keller’s Personalized System of Instruction (PSI)<sup>17</sup>, which has been of periodic interest within engineering education<sup>18</sup>. Examples of such exams based upon mastery learning concepts may be found in the literature<sup>19,20</sup>.

## Prerequisite skills exam

The first prerequisite skills exam for Solid Mechanics was created during the Autumn 2006 semester and implemented for the Spring 2007 semester, with the aim of forcing students to review prerequisite concepts before encountering them in Solid Mechanics<sup>21</sup>. In this exam, the students are allowed multiple attempts to pass the exam, which is offered six or seven times during the first three weeks of the semester. Students receive credit towards their grade in Solid Mechanics, amounting to 5%, which is one-half a letter grade. Credit is only received for a passing score on the exam. A passing score is a minimum of fourteen (14) correct answers out of sixteen (16) total questions, and the 5% towards the Solid Mechanics grades is all-or-nothing.

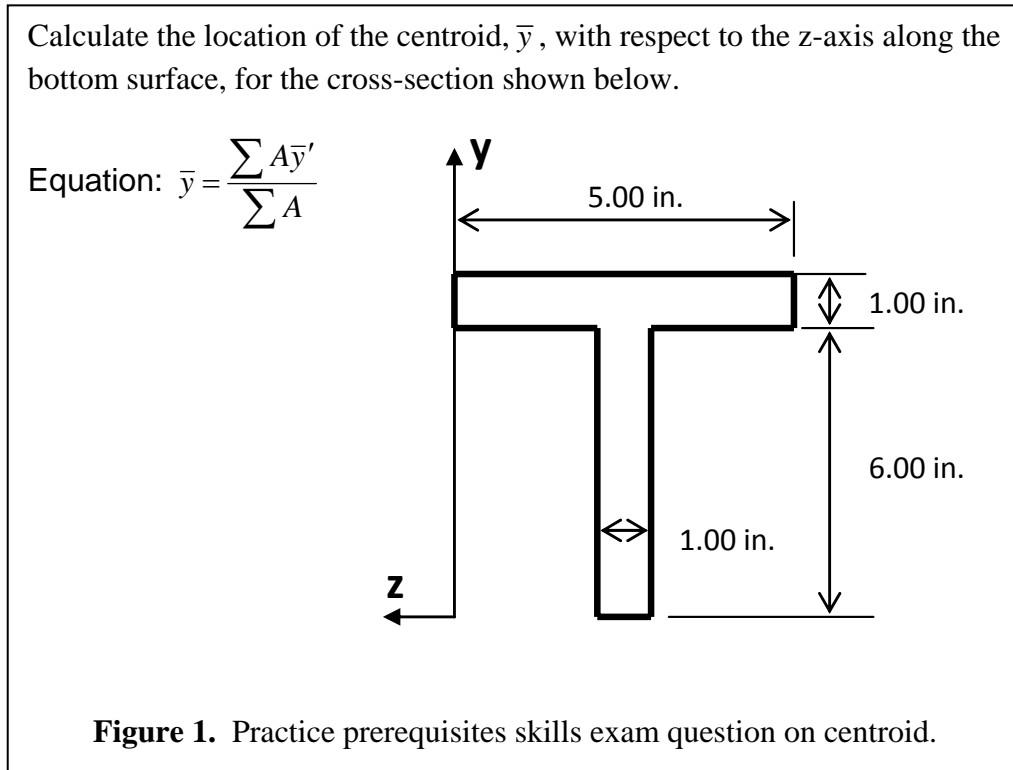
The sixteen questions cover concepts carefully selected to encourage students to prepare for Solid Mechanics by reviewing necessary prerequisite knowledge, primarily from Statics.

Examples of prerequisite skills are:

- a) Calculation of the force in a structural member of a simple two or three member truss.
- b) Calculation of the shear force at an arbitrary location in a beam.
- c) Calculation of the second moment of area with respect to the centroid.

- d) Understanding the concepts of static determinacy and static indeterminacy.
- e) Prediction of the shape of a bending moment diagram for a given shear force diagram.

An example question is shown in Figure 1. The follow-on question asks the student to calculate the second area moment of inertia with respect to the centroids of the same cross-section. The above synopsis of the prerequisite skills exam was first provided in a 2008 ASEE paper by the author<sup>21</sup>, where additional details and an analysis of student performance may be found.



### Student passing rates for the prerequisite skills exam

The prerequisite skills exam (PSE) is presently continuing, and has become a regular part of the Solid Mechanics course, with the exception of Solid Mechanics as taught during the seven-week summer term by another faculty member. The exam was given this Spring 2009 for the fifth consecutive semester during the regular academic year. The author administered the PSE for two sections of Solid Mechanics, but is not the primary instructor for either section during the Spring 2009 semester. During these five semesters of closely following the results, the author has noticed two important items. First, the passing rate is decreasing. Table 1 provides numbers of students enrolled in Solid Mechanics and the number of students not passing the exam.



**Table 1.** Students not passing PSE by semester

Semester	Students enrolled in Solid Mechanics	Students not passing PSE	Percentage not passing PSE
Spring 2007	58	3*	5.2% (12.1%)**
Autumn 2007	27	2*	7.4% (18.5%)**
Spring 2008	56	11	19.6%
Autumn 2008	38	8	21.1%
Spring 2009	75	22	29.3%

\* Seven attempts allowed

\*\* Corrected for only six attempts

The first two semesters the PSE was administered, the author provided students with one additional (a seventh) opportunity to pass the exam, and that affected the passing rates (four and three additional students passed the exam during these two semesters, respectively). This seventh attempt was only offered at the last moment each semester, after the sixth offering was completed. The author then decided to stay with the declared six maximum opportunities thereafter. When one adds these additional passes to the “Students not passing PSE” column, for the sake of equivalent comparison (these are the figures shown in parentheses in the last column), the trend is still evident. Each semester, a slightly higher percentage of students did not pass the PSE. Inspecting certain results not presented here, it appears that this decreased passing rate is generally not due to students attempting the exam fewer times, as was first suspected. It may be that students are preparing less for the PSE, or that students are less prepared from prior course work. Whatever the case may be, this has not been investigated further at the present time, but it is a noteworthy and disturbing trend.

The second thing the author has noted is that those students not passing the PSE were always student that performed poorly in Solid Mechanics, and usually did poorly elsewhere in their academics. Two general explanations can be offered. 1) These students are severely underprepared from prerequisite courses, such as Statics. 2) These students lack the motivation to persevere in a mastery-style exam, and more importantly lack the motivation to complete an engineering degree in our department. The first problem is indicated by the students that attend most or all opportunities to take the PSE, but never achieve a passing grade. The second problem may be observed with students who take the PSE only once or twice, and appear to more-or-less resign themselves to not passing the exam, and perhaps do not like the idea of being pushed to achieve a certain level of mastery of the material. The author recalls one direct questioning of a student who had not attended any of the out-of-class offerings of the PSE. The student said that he “did not believe in the prerequisite skills exam.” The author is to be commended for keeping a cool head. Cynical views aside of such a student attitude towards the PSE, it is worth noting that this student dropped out of ERAU shortly thereafter. It is clear that student attitude played a role in this retention failure.

### Student achievement in Solid Mechanics

The prerequisite skills exam appears to be a harbinger of things to come in Solid Mechanics. Table 2 shows the final outcomes of those students not passing the PSE. Obviously, the final grades are not yet in for the Spring 2009 semester, and these outcomes cannot yet be reported. A grade of “W” is a withdrawal from the course, typically given because the student was doing

poorly, and a grade of “AU” is an audit of the course, also typically given because a student was doing poorly and elected to switch the enrollment to audit the course for no letter grade. The number preceding the grade gives the total number of students receiving that grade.

**Table 2.** Final grades for students not passing the PSE

Semester	Students not passing PSE	Solid Mechanics grades of those not passing PSE	Students passing PSE but receiving D, F, AU, or W
Spring 2007	3	C, D, W	7
Autumn 2007	2	F, W	9
Spring 2008	11	C, 3D, 2F, 5W	3
Autumn 2008	8	3D, 3F, AU, W	9

The first observation is that a student who does not pass the PSE rarely passes with what might be seen as an acceptable grade in Solid Mechanics. Most students not passing the PSE receive Ds, Fs, or elect to withdraw or not take the course for credit. Even though the exam is worth only 5% of the Solid Mechanics grade, which is one-half a letter grade, students have not shown the ability to recover and obtain an A or B in the course, and only rarely obtain a final grade of C. However, there are still a significant number of students who manage to pass the exam and still do not perform adequately in Solid Mechanics, as evidenced by the last column in Table 2. A noteworthy fact, not shown here, is that most of the students that received poor grades yet passed the PSE, indicated in the last column in Table 2, had difficulty passing the PSE, taking many attempts to pass the exam.

An interesting observation can be made upon considering both Tables 1 and 2 together, that while the enrollments in Solid Mechanics are typically lower in Autumn compared to Spring, there are more poor grades given during the Autumn semester. Most students on track to graduate as originally planned take Solid Mechanics during the Spring semester, while students taking it during the Autumn semester are often lagging behind due to poor performance in certain critical prerequisite courses. This generally poor performance in the degree program requirements appears to continue in Solid Mechanics, evident in this higher percentage of students performing poorly in Solid Mechanics during Autumn semesters.

Two of the seven students who passed the PSE during Spring 2007 but received a poor final grade were students who passed the PSE on the seventh attempt. All three of the students passing the PSE on the seventh attempt during the Autumn 2007 semester received a poor final grade also. This might indicate that additional opportunities beyond the sixth become less useful as learning tools for Solid Mechanics.

### **The PSE as a retention tool**

It appears that students who do not pass the Solid Mechanics PSE are not the type of students who can recover from this deficit and perform well in the remainder of the Solid Mechanics course. This can therefore be a warning sign to the instructor that these students need immediate attention if they are to be influenced in a positive manner by faculty and advisors. However, upon digging deeper into these students’ transcripts, it appears that the PSE performance is an

indicator of larger trends. Table 3 shows certain details of these student transcripts, with the students not passing the PSE from Spring 2007 through Autumn 2008 semester referred to as Student 1, Student 2, and so on, for each semester.

**Table 3.** Final grades for students not passing the PSE

Semester	Student	PSE attempts	Solids grade	Ds on transcript	Fs on transcript	AUs and Ws on transcript	Status
Spring 2007	1	3	w	7	0	3	new major
	2	6	c	5	2	2	current
	3	5	d	5	0	0	current
Autumn 2007	1	7	w	3	0	4	not enrolled
	2	7	f	6	4	1	current
Spring 2008	1	4	f	6	9	1	probation
	2	1	w	5	14	2	not enrolled
	3	3	w	8	1	1	not enrolled
	4	2	w	5	3	3	current
	5	2	d	3	1	0	current
	6	1	w	8	2	1	current
	7	5	d	2	1	2	current
	8	1	f	1	3	0	not enrolled
	9	1	d	2	2	0	not enrolled
	10	2	w	3	2	3	not enrolled
	11	2	c	0	1	0	current
Autumn 2008	1	6	f	4	2	3	probation
	2	3	d	2	0	0	current
	3	2	w	0	1	2	current
	4	6	f	3	1	2	current
	5	5	au	2	2	3	current
	6	2	f	4	4	2	current
	7	4	d	1	0	0	current
	8	3	d	2	1	1	current

It is not possible to directly compare these students against each other. The number of Ds, Fs, Ws, and AUs include all grades on the student's transcript, including the Solids (Solid Mechanics) grade. Some students may have transferred credits and those transfer grades are not included here, and obviously the students who took Solid Mechanics during the Spring 2007 semester, and are still currently enrolled, have likely taken more classes than those students taking Solid Mechanics in the Autumn 2008 semester, having had more opportunity to perform unsuccessfully and tally more poor grades. Regardless, certain trends are clear.

Many observations can be made from Table 2. First, quite a few of these students did not take advantage of the full number of opportunities to take the PSE, especially during the Spring 2008 semester. While the statistics for the current Spring 2009 semester are not shown here, the conclusion is similar. Many students essentially elect to fail the exam, whatever the reason may be. Second, almost all of these students have accumulated a track record of poor performance. In fact, some of these students have assembled spectacularly poor transcripts. These students often manage to barely hang on, for an excessive number of semesters, and do themselves no favors when they do not heed the advice given by their instructors and advisors to shape up or ship out, in so many words. It should be noted that a grade of D is considered passing for most

classes at Embry-Riddle (perhaps unfortunately), although students are encouraged to repeat classes in which they receive a grade of D.

Students with such transcripts are clearly at-risk. While only one of these students from the Autumn 2008 semester is currently on probation, the author knows enough about the rest of these students to predict that at least three or four are rapidly nearing serious academic trouble, or are likely to be leaving the degree program shortly. There are additional students from the other semesters who also appear to be nearing the end of their academic career. However, we should also consider the remaining students in this table who somehow manage to graduate to be at-risk in another sense. It is difficult to imagine that students with such transcripts will be able to find the type of job that they have trained for. Further, it is probably not in Embry-Riddle's best interest to have many of these students representing our academic programs.

Finally, while it is clear that the students who do not pass the Solid Mechanics PSE should be identified as at-risk students, it is realized that failing the PSE does not identify all students who end up performing poorly in the Solid Mechanics course (see Table 2). However, when data similar to those in Table 3 are assembled for students who have passed the PSE yet failed to perform adequately in Solid Mechanics, it is usually observed that these students have performed somewhat better in their other classes when compared to the student records in Table 3. Therefore, these students perhaps may not, as a group, be viewed as at-risk with quite the same urgency.

## Summary

The prerequisite skills exam implemented in the author's Solid Mechanics course has produced many qualitative benefits, documented elsewhere<sup>21</sup>. An additional benefit that is now being explored is that it may help identify a significant number of students who are at-risk, or likely to become at-risk, of changing degree programs or leaving the university (and perhaps higher education altogether). The author and other faculty are considering a range of identifiers as aids to retention efforts. The prerequisite skills exam implemented in Solid Mechanics appears to offer such an indicator, although results should be tracked for additional semesters to offer a more complete depiction of student achievement as indicated and predicted by this exam.

## Bibliography

1. Moller-Wong, C. and Eide, A. (1997). An Engineering Student Retention Study. *J. Engineering Education*. January. 7-15.
2. Pascarella, E.T. and Terenzini, P.T. (1991). *How College Affects Students*. Jossey-Bass, Inc., San Francisco, CA.
3. Lovencin, W., Najafi, F., and Safai, N. (2007). A Review of Strategies Employed on Minority Recruitment and Retention in Engineering Education. In *Proceedings of the ASEE Annual Conference and Exposition*. June 24-27, Honolulu, Hawaii.
4. Spring, G.S. and Schonberg, W. (2001). A Study of Factors Contributing to Low Retention Rates. In *Proceedings of the ASEE Annual Conference and Exposition*. June 24-27, Albuquerque, New Mexico.

5. Carter, R.L., Hoit, M., and Anderson, T. (2003). Factors Influencing Freshman Retention in Engineering Programs. In *Proceedings of the ASEE Annual Conference and Exposition*. June 22-25, Nashville, Tennessee.
6. Seybert, T. (2008). A First Year Seminar for Surveying Engineering and the Effects on Retention. In *Proceedings of the ASEE Annual Conference and Exposition*. June 22-25, Pittsburgh, PA.
7. Tezcan, J., Nicklow, J., Mathias, J., Gupta, L., and Kowalchuk, R. (2008). An Innovative Freshmen Engineering Course to Improve Retention. In *Proceedings of the ASEE Annual Conference and Exposition*. June 22-25, Pittsburgh, PA.
8. Milano, G.B., Parker, R., and Pincus, G. (1996). A Freshman Design Experience: Retention and Motivation. In *ASEE Annual Conference Proceedings*. June 23-26, Washington, DC.
9. Baxter, K. and Yates, L. (2008). Addressing Freshmen Retention through Focused Advisement and Seminar Programs. In *Proceedings of the ASEE Annual Conference and Exposition*. June 22-25, Pittsburgh, PA.
10. Whitaker, W. (1999). Benefits of a Successful Retention Program. In *Proceedings of the ASEE Annual Conference and Exposition*. June 20-23, Charlotte, North Carolina.
11. Saviz, C., Fernandez, A., Golanbari, M., Khoie, R., and Watson, K. (2006). A Program to Improve Learning and Retention of First Year Engineering Students. In *Proceedings of the ASEE Annual Conference and Exposition*. June 18-21, Chicago, Illinois.
12. Van Treuren, K., Eisenbarth, S., and Fry, C. (2003). A Retention Study at Baylor University. In *Proceedings of the ASEE Annual Conference and Exposition*. June 22-25, Nashville, Tennessee.
13. Kelley, B.S., Burtner, J.A., and Grum, A.F. (1996). In *ASEE Annual Conference Proceedings*. June 23-26, Washington, DC.
14. Cone, C., Chadwick, S., Gally, T., Helbling, J., and Shaffer, R. (2005). Interdisciplinary Freshman Experience. In *Proceedings of the ASEE Annual Conference and Exposition*. June 12-15, Portland, Oregon.
15. Block, J. (1971). *Mastery Learning: Theory and Practice*. Holt, Rinehart, and Winston, New York.
16. Bloom, B. (1971). *Mastery Learning*. Holt, Rinehart, and Winston, New York.
17. Keller, F.S. (1968). Good-Bye, Teacher... *J. Applied Behavior Analysis*. No. 1, Spring. 79-89.
18. Haws, D.R. (2000). Teacher Gone... The Marginalization of PSI in Engineering Education. In *Proceedings of the ASEE Annual Conference and Exposition*, June 18-21, St. Louis, MS.
19. Carpenter, W. (2007). Proficiency Exams in a Supportive Learning Environment. *Proceedings of the ASEE Annual Conference and Exposition*. June 24-27, Honolulu, HI.
20. Williams, S.M. and Newberry, B.P. (1998). First-Year Experiences Implementing Minimum Self-Paced Mastery in a Freshman Engineering Problem-Solving Course. *Proceedings of the ASEE Annual Conference and Exposition*. June 28-July 1, Seattle, WA.
21. Lanning, D. (2008). Evaluation for Prerequisite Skills Testing for Solid Mechanics. In *Proceedings of the Pacific Southwest Regional ASEE Meeting at Northern Arizona University*, March 27-28, Flagstaff, Arizona.

**Biography**

David Lanning is an Associate Professor of Aerospace and Mechanical Engineering at Embry-Riddle Aeronautical University in Prescott, Arizona.

## **The Capstone Design Experience in the Mechanical Engineering Department at California State University, Fullerton**

Dr. Jesa H Kreiner, Dr. Peter W. Othmer & Dr. Timothy W. Lancey  
Professors

Mechanical Engineering Department

California State University  
Fullerton, CA 92834

### ***Abstract***

The terminal learning experience in the mechanical engineering program at California State University, Fullerton is the series of two design classes: ME 414 and ME 419 taught respectively in the Fall and Spring semesters. These two courses have the goal of immersing the students in the real-life engineering problems where they are engaged in systematic application of the principles of design and solving open-ended problems for specific situations and/or needs and in utilizing knowledge acquired during their studies at the University. Design is about testing ideas, failures and successes and solving problems as these appear during the semester. Decisions have to be made at each step of the process, compromises must be reached among the team members, optimization of components is done and ultimately the project must be fabricated, tested and it must perform as stipulated, that is the requirement that the department has imposed on each and every design project. The principal objective of this sequence of courses is for the students to develop an understanding of the design process as it applies to a serious mechanical engineering project. Students must be able to select standard off-the-shelf components as well as design non-standard mechanical sub-systems. One of the key features of these two courses is the creative utilization of contemporary software packages i.e. Pro-E, Fluent, Ansys, Solid Works as well as MathCad, MatLab, AutoCad and Project Management software. Simulation is readily utilized and the students readily appreciate ability to virtually analyze a real system rather than engage in costly sequence of physical prototypes designed iteratively by intuition and/or trial-and-error prior to building a physical prototype. Strict requirements are maintained in developing the RFP and subsequently the proposal for the projects, maintaining the documentation of the progress, adherence to the Gantt chart and communications with the vendors and/or fabricators. Cost issues are carefully evaluated and teams are mandated to stay within the allocations given either by the instructors or industrial sponsors. Project teams are strongly encouraged to seek additional funding from sources within and without the University, i.e. from chapters of professional organizations (ASME, SAE, SAMPE), Orange County Engineering Council - the umbrella organization of all engineering societies within Orange county and from major industrial corporations such as Boeing, Fluor, Parsons, General Dynamics, Lockheed-Martin, Hughes etc. The projects given to the teams vary so as to meet their individual interests ranging from biomedical projects, automotive (Mini Baja, Drift Car, Formula One), avionics, renewable energy, equipment for the handicapped... Teams are carefully created with the intentions of balancing students' talents and skills as well as their desires to work with their friends. The penultimate results are a working prototype and a portfolio detailing all elements of each of

the design projects. The Power Point or similar presentations which take place at the end of the semester in front of Design Juries is the climactic event of the courses where the defenses of the projects are conducted and which is a significant component of the grades given to each design team member for their performance and contributions to the project.

### ***Introduction***

Contemporary work environments request/mandate that engineers be able to participate in work on diverse projects and make their contributions to the effort. Therefore it is incumbent on the Universities teaching design to provide the requisite learning experiences preparing the future engineers to hit the ground running and deliver what is expected of them. The Capstone Design experience at California State University, Fullerton has as its goal to provide this experience<sup>2</sup>. The theme of the experience is set jointly by the students and faculty during the beginning of the first class. Interests of the students are explored and evaluated and ideas for projects requested. Subsequently, additional ideas are brought for consideration by the teaching faculty. Usually, these are projects obtained from local industry or from different parts of the University. The discussions about which projects to select are an integral part of the course as the financing of the projects with respect to the ability of the department to fund these is of course quite limited. The current financial circumstances in the university and the inability of the department to provide any funding whatsoever curtails the ability of engaging in more ambitious and more complex projects. That placed tremendous pressures on the instructors of the course to obtain the requisite resources for the conduct of the classes. Prior to the day the projects were actually assigned to the students another serious aspect which had to be considered was that not all students came with identical background, but with a wide array of talents, manual and computer skills, experiences, cultural backgrounds etc so that creating teams that could and would function harmoniously presents a rather complex task. An additional aspect to the original purpose of the capstone courses was satisfaction of the ABET requirements regarding design activities, specifically with “an ability to design a system, component, or process to meet desired needs” as well as to possess “an ability to use the techniques, skills, and modern engineering tools necessary for engineering practice”. This was achieved through ongoing discussions and progress briefings with each of the teams as well as confirmed by the assessments of the design juries and the mechanical engineering advisory board members providing inputs to the student teams.

### ***Conduct of the Capstone Design Courses***

Matching the students’ interests turned out to be a harder task than originally thought to be. Every student had visions of working in their own field of interest which is unlikely to take place in most work environments. Yet, the authors know from long standing experiences that if the students are energized with the assignments close to their hearts they would invest the time necessary for the project and deliver better products. The majority of the students prefers and enjoy working on projects which involve competitions, i.e. Mini Baja, Human Power Vehicles and Human Powered Submarine, SAE Air Cargo, Drift Car, SAE Formula One car, ASME Super Mileage vehicle... The pace of these projects is dictated by the deadlines which each of the competition entails and are excellent examples of the pace



encountered in industrial settings. While these projects entail excellent engineering challenges they are also good for the reputation of the program as well as for building and maintaining connections with the alumni. Yet, one of the authors of this paper prefers projects which have a more humanistic nature and are for the benefit of the society such as designing equipment for the handicapped, items that are usable in Kinesiology department of our university like The Stability Platform, New Surgical Devices, equipment that aids rehabilitation of the patient after surgery, design for the elderly and for eclectic projects for the local industry such as the aircraft winch, camera for inspection of various structures, re-design of wheelchairs, robotic painting devices...<sup>10</sup>. There are several additional interesting aspects of conducting the capstone design courses which include discussions of selected case studies from the ASEE Case Studies Committee Library which is currently at Rose-Hulman Institute of Technology in Terre Haute, Indiana, analysis of some more prominent failures encountered in the engineering practice along with demonstration of some of the movies illustrating these<sup>11</sup>. Safety concerns were emphasized during the conduct of both of the courses with numerous illustrations as to how failures occurred and how the prevention of these could have been achieved<sup>9</sup>. Human Factors and Safety concepts were discussed at length and examples of product liability cases brought to the students' attention in order to sensitize them to that paramount canon of the ASME Engineering Codes of Ethics which is that "Engineers shall hold paramount the safety, health and welfare of the public in the performance of their professional duties" and that "Engineers shall recognized that the lives, safety, health and welfare of the general public are dependent upon engineering judgments, decisions and practices ..."<sup>4,8</sup>. Different hazards in design must be recognized and dealt with in the optimal way i.e. kinematic, energy, electrical, chemical, material, environmental, ergonomic ones etc<sup>5,7</sup>. Also, it is important to recognize potential for misuse or abuse of products, particularly with regard to maintenance aspects. Ethical issues of the engineering practice are discusses with regard to the well known engineering cases<sup>4</sup>. Maintenance of weekly logbooks of progress, or lack thereof, was an integral part of the requirements for the course which had to be met. These were inspected by the course instructors and signed off on the weekly basis. The contents of these logbooks had to be scanned and presented with the final design project report along with the specifications of purchased off-the-shelf items. Fabrication of projects was done mostly at the facilities within the University with able assistance of our machine shop. Students have previously learned to utilize most of the machine tools within the shop and were doing a good amount of the machining themselves. Some of the fabrication was outsourced when necessary. The importance of avoiding obsolescence is being impressed throughout of the courses as is the need to pursue learning throughout one's career<sup>6</sup>.

### ***Funding of the projects***

The California fiscal crises notwithstanding, the funds for the projects have for years originated as a result of the instructors' entrepreneurial efforts and activities. The bulk of the funds have been secured by submitting proposals to the CSUF student government's IRA – Instructionally Related Activities fund which has enthusiastically supported the project activities. The fund's resources hail from students' fees. Proposals for the funding of the projects undergo a rigorous scrutiny of a large committee consisting of students, faculty and administrators. The committee then allocates the funds to those projects it deems to be

worthwhile. The support of the different project activities is a long standing tradition at the university and has contributed to numerous ambitious and sophisticated projects across the spectrum of different disciplines. Some mechanical engineering projects have been funded by the local industry for a variety of reasons: the projects are of the type that are not of an urgent nature and are on the proverbial “back burner” so that the time for completion is not of essence, the projects can be done over the two semester period which is the duration of the two capstone courses, the only costs of the projects are the components and fabrication as the students’ and faculty labor come free. The industry funded projects serve as an excellent recruiting tool for new engineers where the company engineers interact with our students and can evaluate their prospective contribution and subsequently decide if they should be hired upon graduation. Also, it is a good public policy for companies to maintain active relationship with the biggest local University in Orange County. Interestingly enough, some projects were directly and completely funded by the students or their families. The rules for these rare projects were clearly laid out: if any funds whatsoever utilized in the projects come from the University the project remains property of the University. If the project is completely funded externally it belongs to the source of funding. However, the owners of the project must *a priori* agree in writing to let the University be able to loan the prototype for special occasions such as Open House Tours, ABET visits, Job Fairs etc with the appropriate time notice. Interesting situations arise from time to time with respect to the intellectual property associated with the projects as some have potential to generate income once a patent is issued. These have been handled on a case by case basis. In some circumstances the University has yielded the patent rights to the sponsor of the project while in other a sharing of future income has been negotiated. Pursuit of patent rights is an expensive process and has been in most cases left to the sponsor of the project yielding a larger share of potential future profits. Instructors have waived their rights to the benefits but retained the rights to be named on the patents, if granted. The intent of the department has from the inception of the projects been that the students are not expected to contribute to funding of any of the projects. In view of the cataclysmic changes taking place at this very time this approach may regrettably have to be changed? The projects originating from industry have been the result of the active Departmental Advisory Board as well as a result of the good relationship with the alumni of the program who cherished opportunities to be engaged and help their Alma Mater. During the conduct of the courses the students were encouraged and guided to seek support for their projects on their own. They were taught how to write granting proposals and seek out sponsors for their efforts. The support requested was in form of cash, components, discount on purchases, help with travel arrangements etc. The sponsors would, in turn, obtain favorable publicity as their logos would be posted on the project. Additionally, the students were encouraged to give presentations to chapters of the professional engineering societies and seek their support as well. The learning curve on fund raising was a steep one as very few students, if any, did ever anything similar but they rose to the occasion and were successful in their efforts.

### ***Use of Modern Design Tools***

It is difficult to envision contemporary design without a comprehensive utilization of modern computational tools. Student teams were provided with numerous software

packages acquired by either the university or the mechanical engineering department such as AutoCAD, Fluent, MathCad, MathLab, Project Management software, Solid Works, ProE, Cosmos, Ansys etc<sup>3</sup>. Additionally, most projects required usage of specialized software which was purchased, if affordable, to support the design activities at the appropriate technical level of sophistication. The Air Cargo project utilized NASA Airfoil design software and Simufoil, the Mini Baja utilized software for modeling of the suspension of the vehicle and shock and vibration behavior of the frame. Every effort is made during the conduct of this (and other) courses that the word processing, spreadsheets, Cad/Drafting, project management, internet communications and web browsing are in the inventory of the skills of our graduates. The car related projects represent ideal settings to learn object related programming as software allows modeling of various physical components of the car: its engine, transmission, differential, tires, steer mechanism, suspension etc. Students were able to design a car within the constraints provided. Many of the other projects also lend themselves to computational modeling of components and systems.

### ***Communication Skills***

Engineers are to be employed in a wide variety of business functions, for example: Technical marketing, product research and design, plant operations, fabrication and their ability to successfully perform in these functions demands that they be good communicators both in writing and in oral presentations. During the capstone design courses teams were mandated to regularly deliver progress reports by using Power Point presentations. The resistance to this requirement was palpable, particularly from students with the foreign background, but after some time passed the students were able to deliver good briefings and to choreograph their presentations. The instructors encouraged questions and answers engagements which resulted in interesting discussions involving the entire student body of the class. Ultimately, at the end of each semester, the teams gave final presentations to the instructors and the design jury specially constituted for this purpose. The members of the design jury challenged the teams with the questions related to the alternatives considered when doing the arriving to a particular decision. Another interesting aspect of communication was the interaction with suppliers. The contact had to be made with different manufacturers and information was sought regarding to specific components performance as well as the cost of these. Students had to research the companies producing the said components, obtain the technical specifications and data and ultimately select the optimum one for their application with the appropriate cost for it<sup>1</sup>. Members of the Mechanical Engineering Advisory Board interacted with the teams on several occasions and provided much of valued constructive critiques. Members of the Board have also reviewed the final reports of the teams for both semesters and offered their comments and suggestions for improvements. Efforts were made to ascertain the proper level of literacy in the reports with respect to grammar, syntax, spelling, vocabulary to make them achieve the desired high standard. Since a large number of students were foreign born this required a special effort on behalf of the instructors.

### ***Information Gathering***

Every team had to evaluate the current state of the art of the know-how of the project it was working on. That required extensive information gathering both by conventional means in library searches and by contemporary methods via search engines, patent searches, visits to the industry and interviews with engineers knowledgeable with the product. Of immense help were the briefings of the reference librarians of the California State University, Fullerton. They met with each team separately and helped them identify the sources which would be helpful in their work; the published works of the persons engaged in the like efforts and have obtained, via interlibrary loans, documents pertinent to the individual searches. Their contributions to the effort cannot be adequately recognized as their knowledge and skills in the searches significantly abbreviated the students' efforts and lead them directly to the most appropriate sources and taught them to avail themselves of these powerful contemporary tools.

### ***Conclusions***

Universities and educators are working together to identify requisite engineering skills and abilities for the entry level engineers and to facilitate their transition from the graduating senior to an engineering professional who carries his or her own weight in the industry<sup>12</sup>. There is no better opportunity to do so than in the capstone design projects courses such as the ones discussed in this paper. The constantly evolving industrial practice demands that a constant vigil and attention be given to determining which evolving skills are to be required of current graduates and where and when are these to be introduced and practiced. The successful projects in the ME 414 and ME 419 courses proved to be valuable to the graduates of the CSUF mechanical engineering program as their portfolios of the final design projects were convincing documents about their competency in the profession, written and oral communication skills, leadership abilities and indeed most helpful during the interview process for steady employment.

### ***Appendix***

Examples of projects accomplished in the ME 414 and ME 419 Capstone Design courses at CSU Fullerton

- SAE Mini Baja
- Drift Car
- SAE Formula One Vehicle
- Human Powered Vehicle
- Human Powered Submarine
- ASME Super Mileage Vehicle
- SAE Air Cargo Plane Design
- Bowling Machine for Handicapped Persons
- Frisbee Thrower for Handicapped Persons
- Landsailer Design
- Rehabilitation Device for People after Hand/Finger Surgery
- Tool to Assist Surgeon during Surgery and Reduce Hemorrhage
- Ankle Testing Device for Kinesiology

Balance Response Platform for Stability Assessment for Kinesiology  
 Rehabilitation Device after Knee Surgery  
 Lift for Placing and Extracting of a Handicapped Person to the Pool  
 Robotic Painting Device  
 Conversion of an Internal Combustion Automobile into an Electric Vehicle  
 Hovercraft Vehicle Design  
 Platform for Mounting Inspection Cameras  
 Thermal Management Unit  
 Solar Hot Dog Cooker  
 Automatic Shish Kebab Machine  
 Rickshaw Design  
 Sterling Engine  
 Movable Mirror Focusing Solar Collector

### ***References***

1. Kreiner, Jesa, "A Contemporary Method of Teaching Machine Design Courses". Event # 1824, 86<sup>th</sup> Annual Conference of the ASEE, University of British Columbia, ASEE Journal October 1978, Vol. 69.
2. Kreiner, Jesa and S. Krishnamurthy, "Relevance of Capstone Design Experience to Mechanical Engineering Practice", Proceedings of the ICED International Conference on Engineering Design, August 1990, Dubrovnik, Yugoslavia, pp 2158-2160
3. Chandra Putcha and Jesa Kreiner, "A Computer Aided Technique for Shaft Design Through Monte Carlo Simulation", International Journal of Computers and Structures, Vol. 52, No.2, 1994
4. Kreiner, Jesa and Albert Flores, "Contemporary Ethical Issues Facing Engineers", Proceedings of the International Conference on CAD, CAM and Robotics (INCARF), New Delhi, India, December 16, 1993.
5. ASME International Code of Ethics
6. David Miles and Jesa Kreiner, "Efforts in Maintaining Currency in Engineering and Avoiding Obsolescence". {Proceedings of the 2007 ASME International Mechanical Engineering Congress and Exposition, Seattle, Washington, November 11-15, 2007, paper IMECE2007-43841.
7. Kreiner, Jesa, "Use of Hazard Pictorials/Symbols in the Materials Handling Industry", Proceedings of the XIV International Conference on Material Handling and Warehousing, Dec. 11-12, 1996, Belgrade, Yugoslavia pp 3.7-3.12.
8. Charles E. Harris, Pritchard, Michael, and Rabins, Michael, "Engineering Ethics –Concepts and Cases, 3rd edition, Thompson and Wadsworth, 2005.
9. Jesa Kreiner and Putcha, Chandra, "Ethical and Professional Issues Facing Engineers in Global Settings", Proceedings of the 4<sup>th</sup> ASEE/AaeE Global Colloquium on Engineering Education – Cluster E-1, Sydney, Australia, September 26-29, 2005.
10. Timothy Lancey and Kreiner, Jesa "Senior Design Projects for Medical Devices", presented at the 2007 EPICS – NSF National Conference, organized by Purdue University, San Diego, California May 22-24, 2007.
11. Catalog of Case Studies Reports, ASEE Center for Case Studies in Engineering, Rose-Hulman Institute of Technology, Terre Haute, Indiana.
12. Johnston, Stephen, J. Paul Gostelow and W. Joseph King, "Engineering & Society", Prentice Hall.

### ***Biographies***

JESA KREINER, Ph.D., PE is a professor of mechanical engineering at California State University, Fullerton. His Ph.D. is from Oklahoma State University. He teaches courses in machine design, mechanical behavior of materials, human factors engineering and composite materials. He is an author of over one hundred technical publications and contributor to several books. Dr. Kreiner is a Fellow of SAMPE – Society for Advancement

of Material and Process Engineering and of the Institute for Advancement of Engineering. His principal research interests are in fatigue, behavior of composite materials, safety, engineering ethics and continuing education. He is a recipient of many different awards: Distinguished Educator of Orange County, CSUF Distinguished Alumni Service award and the CSU Bautzer University Advancement Award.

PETER OTHMER, Ph.D., PE is a professor of mechanical engineering at California State University, Fullerton His Ph.D. is from University of California, Los Angeles. Dr. Othmer teaches courses in thermodynamics, fluid mechanics and heat transfer. He has an active interest in improving the laboratory experience in the engineering curriculum. Dr. Othmer's research interests are in energy conservation and in solar and other alternative energy sources.

TIMOTHY LANCEY, Ph.D., PE is a professor of mechanical engineering at California State University, Fullerton. His Ph.D. is from the University of Southern California and his teaching and research interests are in acoustics, noise from fluid/solid interaction and mechatronics. His honors include the following: Fellow of ASME, Carl Pister Award for Outstanding MESA Pre-College Education, Distinguished service award for service on the ASME Board on Pre-College Education. He is an author of numerous papers published in a variety of journals and proceedings of conferences in the USA and abroad.

# Application and Practice of Sustainable Development in Engineering

Hassan Badkoobehi  
National University, San Diego, CA

**Abstract**— In recent years there has been an ever increasing need for sustainable design. However sustainable design sometimes may be in conflict with existing design standards. The topic that this study addresses is the ethical dilemma between design standards and Sustainable design. This is a newly arising conflict resulting from the recent “green” Movement. This is a new challenge facing the modern engineer. This is a problem that the new generation will have to learn to understand and deal with.

**Index Terms**—sustainability, renewable energy, waste minimization, and green building.

## I. INTRODUCTION

The duty of an engineer first and foremost is always the health and safety of the public. Specifically Canon 1 which states “Engineers shall hold paramount the safety, health and welfare of the public and shall strive to comply with the principles of sustainable development in the performance of their professional duties.” In general design standards have been written and constructed to help engineers uphold this standard of protection of the public either by negligence or unethical conduct. However the duty of the engineer goes well beyond health and safety. A major concern in the modern world is the sustainability of our modern life style. This is where the term “Sustainable Design” comes from. The Government Sustainable Administration (GSA) has defined sustainable design in the following manner: “Sustainable design seeks to reduce negative impacts on the environment, and the health and comfort of building occupants, thereby improving building performance. The basic objectives of sustainability are to reduce consumption of non-renewable resources, minimize waste, and create healthy, productive environments. Sustainable design principles include the ability to: optimize site potential; minimize non-renewable energy consumption; use environmentally preferable products; protect and conserve water; enhance indoor environmental quality; and optimize operational and maintenance practices. Utilizing a sustainable design philosophy encourages decisions at each phase of the design process that will reduce negative impacts on the environment and the health of the occupants, without compromising the bottom line. It is an integrated, holistic approach that encourages compromise and tradeoffs. Such an integrated approach positively impacts all phases of a building's life-cycle, including design, construction, operation and decommissioning”[2].

## II. METHODOLOGY

It may arise as an ethical dilemma torn between conflicting principles of design standards and sustainable design. The Internet Encyclopaedia of Philosophy defines Ethic in the following manner: “The field of ethics, also called moral philosophy, involves systematizing, defending, and recommending concepts of right and wrong behaviour. Philosophers today usually divide ethical theories into three general subject areas: Met ethics, normative ethics, and applied ethics. Met ethics investigates where our ethical principles come from, and what they mean. Are they merely social inventions? Do they involve more than expressions of our individual emotions [3]? Met ethical answers to these questions focus on the issues of universal truths, the will of God, the role of reason in ethical judgments, and the meaning of ethical terms themselves. Normative ethics takes on a more practical task, which is to arrive at moral standards that regulate right and wrong conduct. This may involve articulating the good habits that we should acquire, the duties that we should follow, or the consequences of our behaviour

on others. Finally, applied ethics involves examining specific controversial issues, such as abortion, infanticide, animal rights, environmental concerns, homosexuality, capital punishment, or nuclear war[1]. By using the conceptual tools of met ethics and normative ethics, discussions in applied ethics try to resolve these controversial issues. The lines of distinction between met ethics, normative ethics, and applied ethics are often blurry. For example, the issue of abortion is an applied ethical topic since it involves a specific type of controversial behaviour. But it also depends on more general normative principles, such as the right of self-rule and the right to life, which are litmus tests for determining the morality of that procedure” [4]. This paper is an examination of the key issues in the ethical conflict that may arise in the ever growing need for sustainable design. Some key ethical issues must first be highlighted before exploring the more specific ethical issues surrounding sustainable design. Let us first explore the 2nd Canon in the ASCE Code of Ethics “Engineers shall perform services only in areas of their competence”[5]. This represents a dilemma quite often and over a range of circumstances. The ethical conflict comes either from over zealously seeking work in an area that the engineer is not qualified, or from ignorantly accepting work without properly researching the qualification required to aptly perform the task. There is one very notable caveat to this rule, an engineer who is wholly incompetent should perhaps seek another line of work that they are qualified for [2]. In the Fundamental Principles of the ASCE Code of Ethics the third principle reads “Engineers uphold and advance the integrity, honour and dignity of the engineering profession by striving to increase the competence and prestige of the engineering profession”. This particular passage especially applies to those engineer who find themselves in a position of instructing and training young and aspiring or student engineers and is one of particular weight and importance. There is another area of this ethical dilemma to explore. That is the duty of the engineering firms to educate their engineers in the newly evolving sustainable design technology as it becomes available. Programs such as “The Leadership in Energy and Environmental Design” (LEED) certification are often supported by employers. Many firms will foot the bill for taking the LEED exam and becoming a LEED Accredited Professional.

### III. RECOMENDATIONS

Sustainable design is an inseparable, dynamic, concentrated, and necessary effort to continue the modern way of life. The United States Green Building Council(USGBC) explains sustainable design in the following way “The Leadership in Energy and Environmental Design (LEED) Green Building Rating System™ encourages and accelerates global adoption of sustainable green building and development practices through the creation and implementation of universally understood and accepted tools and performance criteria.”<sup>5</sup> It is through programs such as LEED that engineers can confidently move into sustainable design and avoid ethical issues with out of date design standards. LEED is the forefront in sustainable “green” design. Many design firms are onboard with sustainable design, it has in fact become a selling point for consultant services. LEED is at this point in engineering history the first system to allow for engineers to have standards for sustainable design. The ethical conflict will diminish with time as standards are developed, amended and revised to reflect the need for sustainable design [1].

### IV. CONCLUSION

Why do engineers focus with such zeal on "engineering ethics?" Ethics are ethics. Have we, by creating a set of ethics for our professional lives as engineers, made the concept of ethical behaviour so complex and confusing that we fail to act in ways consistent with moral principles when faced with an ethical dilemma? Studies show that there is a set of guiding universal principles that if properly applied would provide guidance for dealing with ethical dilemmas. In theory, the study of engineering ethics should not be necessary if engineers were well founded in the application of these principles. Because of the complexities involved in ethical dilemmas, engineers must develop their ability to apply moral intelligence (knowledge of what is right) when we are under pressure in real-life situations. The way we learn to apply this moral intelligence is by studying ethics so that when we are faced with an ethical dilemma we can reply in a manner that is consistent with these universal principles” [5].



## V. REFERENCES

- [1] <http://www.sillmanwright.com/page2.html> Sillman Wright Architects web page ASCE Canons and Ethics, 2003.
- [2] [http://www.gsa.gov/Portal/gsa/ep/contentView.do?contentId=8154&contentType=GSA\\_OVERVIEW](http://www.gsa.gov/Portal/gsa/ep/contentView.do?contentId=8154&contentType=GSA_OVERVIEW), The Leadership in Energy and Environmental Design, 2007
- [3] <http://cweb.salisbury.sa.gov.au/manifest/servlet/page?pg=10527> The Mawson Centre, Environmental Ethics, 2006
- [4] <http://www.iep.utm.edu/e/ethics.htm> Internet Encyclopedia of Philosophy “Ethics” Page Introduction Sustainability, 2008
- [5] <http://www.usgbc.org/DisplayPage.aspx?CMSPageID=222> “LEED, 2005

## Is There a Correlation Between Conceptual Understanding and Procedural Knowledge in Introductory Dynamics?

Lora Goodwin, Brian P. Self, and James Widmann  
California Polytechnic State University  
San Luis Obispo

### Abstract

Engineering professors are usually quite successful at teaching their students to choose an appropriate equation and then substitute appropriate numbers into that equation. This procedural knowledge is practiced on homework problems, quizzes, and tests. By the end of their collegiate careers most students become reasonably skillful at these types of tasks. What is more uncertain is if these students actually graduate with a deep conceptual understanding of their course material.

Students tend to struggle with the course content in Introductory Dynamics. This is often the first rigorous course in engineering that a student takes, and much of the content seems counter-intuitive. Many students continue to talk about the force that “throws you outward” when you are travelling in a curve, and struggle to understand that a rotating mass has more kinetic energy than one that is translating. We have assessed student conceptual understanding by administering the Dynamics Concept Inventory (DCI) before and after the course. The scores on the DCI will be correlated to scores on a midterm test and a final exam to see if there is a correlation between student conceptual knowledge and procedural knowledge.

### Background: Procedural Knowledge versus Conceptual Knowledge

Procedural knowledge typically classifies knowledge of processes, algorithms or specific steps involved in completing a problem or task. This type of knowledge plays a very important role in completing tasks which require hands-on experience, or in solving problems which may arise often or need to be completed quickly without time for thought or analysis<sup>[1]</sup>. Procedural knowledge, however, has limitations and does not necessarily correspond to a strong conceptual understanding of the concepts at hand. It is typically applicable to one specific situation and cannot be extended easily beyond equivalent problems.

Typically, the development of conceptual knowledge in students is advantageous in engineering academia in order to help them gain a deeper understanding of the fundamental concepts. Conceptual knowledge is a rich understanding of the underlying concepts involved in a topic. Streveler, Litzinger, Miller and Steif describe this type of knowledge as necessary in the development of ‘engineering judgement’ or ‘heuristic thinking’<sup>[2]</sup>. A conceptual understanding of kinetic energy, for example, would include an understanding of the different types, translational, rotational and vibrational, along with the ability to apply them to a given problem. A student with only a procedural knowledge of kinetic energy may be familiar with the types of kinetic energy that they have used before to solve a problem, and may only be able to apply their

knowledge to problems similar to those they have previously seen, but may not be able to adapt their techniques to new problems or scenarios. It is often difficult for teachers to succeed at producing full conceptual understanding in students so in the interest of student development it is necessary to research how this challenge can better be met <sup>[3]</sup>.

The relationship between conceptual and procedural knowledge has been a topic of research within the math and physics communities for some time, but has only recently emerged in the engineering community, specifically in the topic of introductory dynamics at California Polytechnic State University in San Luis Obispo. Introductory dynamics is a beginning level core engineering course which contains a wide array of concepts that students often struggle to fully understand. With a better understanding of how conceptual and procedural knowledge are related, instructors in this field could adapt their teaching styles to better provide their students with the opportunity to gain deeper understanding of the introductory dynamics concepts <sup>[4]</sup>.

According to Rittle-Johnson and Wagner Alibali, a relationship clearly exists between conceptual and procedural knowledge in the subject of mathematics, but it is not yet clear as to which type of knowledge influences the other. Evidence shows that conceptual and procedural knowledge may feed off of one another and develop iteratively for most students. This would imply that both procedural knowledge and conceptual knowledge are required to gain full understanding of a concept, and teachers must cater to both to ensure their students have the opportunity for success. On the other hand, some studies suggest that procedural knowledge does not encourage the growth of conceptual knowledge, implying that proper conceptual instruction in the classroom is critical to student's growth in the subject <sup>[5]</sup>. It is difficult to accurately test for an iterative relationship with existing tools, but it is possible to further test the general relationship and the order of influence between the two knowledge categories. To relate this to the instruction and learning process in introductory dynamics, a concept inventory was developed to measure conceptual understanding.

### **The Dynamics Concept Inventory (DCI)**

The development of the Dynamics Concept Inventory (DCI) began in 2003 and was first publicly released in January of 2005. The purpose of the DCI is similar to that of the Force Concept Inventory (FCI) which is already widely used as a teaching aid in the physics community <sup>[6]</sup>. Since its release, the DCI has been used at a series of universities to determine how much conceptual knowledge is gained through an introductory dynamics course. It consists of 29 conceptual multiple choice questions relating to the fundamental concepts presented in the course, which students often struggle to grasp. These concepts range from conservation of energy to direction of friction forces, and to velocity and acceleration magnitudes at different points on a moving rigid body. All questions and multiple choice options in the inventory were carefully selected after discussion between a selection of experienced engineering professors and in depth testing on and with students (for further discussion on the development and content of the DCI, see [7]).

## Testing Gained Conceptual Knowledge in Introductory Dynamics

Data has been collected at California Polytechnic State University, San Luis Obispo, in a selection of introductory dynamics courses in an attempt to measure how well students learned the key concepts presented in the course. The DCI was given on the first day of the class, then again on the last day of the class, to obtain pre and post scores for each individual who completed the course. This was done in 8 different course sections with 3 different instructors to gain a wide spread of data. Two different styles of dynamics instruction were used in these courses. We will call the first group the Active Learning (AL) sections taught by two different instructors and the second group the Traditional (Tr) sections taught by a single instructor. The AL sections utilized collaborative learning and Model Eliciting Activities (MEA's), where the Tr sections were taught in a more traditional lecture format.

The AL sections were specifically given MEA's as a part of their coursework to see if they would have an impact on student's gained conceptual knowledge throughout the quarter. MEA's are new teaching tools being developed which use project-oriented assignments that aim to promote real-world application of engineering principles. Their focus is to use student's conceptual knowledge to solve problems outside of the typical textbook procedural problem range (for further description of the purpose and development of MEA's, see [8]). The change in DCI scores between pre and post scores of the students in the AL sections who used MEA's were compared to that of the classes who did not use MEA's. More specifically, the MEA given to AL sections involved applying work energy methods and conservation of linear momentum to accident reconstruction cases. Students completing this MEA were required to develop a model to aid police in determining the cause of accidents given any amount of data which could be collected from the crime scene. Four police cases involving different types of car accidents were then given to students to solve using the model they developed. Work energy and conservation of linear momentum were the fundamental concepts which needed to be applied to find initial velocities of the cars involved in the impact in order to solve the cases.

The data were analyzed in two ways: first by comparing average pre and post DCI scores of the different classes to see if any MEA impact was evident, and secondly by comparing each individual's post DCI score and final exam score to find any relationships between gained conceptual knowledge (post DCI and conceptual portion of final exam) and gained procedural knowledge (procedural portion of final exam) both in terms of average normalized gain. These comparisons can reveal whether or not there is any sort of correlation between DCI scores and final exam scores, as well as if any impact is shown concerning the use of MEA's. Comparisons of normalized gains were used in analyzing DCI scores as used by Hake in his analyses of the Halloun-Hestenes Mechanics Diagnostic test as well as the Force Concept Inventory<sup>[3]</sup>.

All data was collected at California Polytechnic State University in fall 2008 quarter. In total, the scores of 154 unnamed dynamics students in the AL sections who completed both the Pre and Post DCI exams, as well as the final exam, were used in the analysis. Additionally, the pre and post DCI scores of 80 students in the Tr sections with unknown final exam scores were used in the MEA analysis.

## Results: Comparison between Pre and Post DCI Scores

The overall results given in Table 1 show a larger percent improvement and a larger normalized gain from pre to post DCI scores for the students who participated in MEA's compared to those who did not complete any MEA's in their coursework. The definition of average normalized gain which was used in this analysis was popularized by Hake as a means to accurately evaluate learning levels. In words it is the ratio of the average gain to the maximum possible average gain [7].

$$\text{Average Normalized Gain} = \frac{\% \text{Post} - \% \text{Pre}}{100\% - \% \text{Pre}} \quad (1)$$

**Table 1.** Total pre and post DCI scores for all MEA and non-MEA participants.

	N	Value	Pre DCI Results [%]	Post DCI Results [%]	Overall Average Normalized Gain [%]	Overall Average Percent Improvement [%]
MEA in Coursework	149	Mean	29.85	49.97	29.6	20.11
		Median	27.59	48.28		
		Standard Deviation	14.55	17.20		
No MEA's in Coursework	80	Mean	32.97	46.64	21.1	13.66
		Median	31.03	44.83		
		Standard Deviation	14.19	18.33		


To further and more accurately compare DCI results to the completion of MEA's, the topic of the MEA which the students completed was compared to the scores on only the DCI questions directly related to that topic in terms of normalized gain. Questions 18 and 20 were selected from the DCI as the most conceptually related questions to the tools students should have learned by completing the Accident Reconstruction MEA. Specifically, questions 18 and 20 in the DCI test for conceptual understanding of what happens after an impact. These questions are shown below in Figures 1 and 2 respectively. The results, when only considering these two DCI questions, are shown in Table 2.

<p><b>Question 18</b></p> <p>An impact occurs between two identical wooden balls that are sliding on a frictionless horizontal surface. The impact is non-ideal, that is, the coefficient of restitution is greater than zero and less than one. Which of the following statements is <i>always</i> true.</p> <p>(a) The sum of the kinetic and potential energy for each individual ball, before and after the impact, stays the same.</p> <p>(b) The sum of the kinetic and potential energy for each individual ball, before and after the impact, decreases.</p> <p>(c) The potential energy of each ball decreases during the impact.</p> <p>(d) The kinetic energy of each ball decreases during the impact.</p> <p>(e) The sum of the potential and kinetic energies for the balls taken together decreases during the impact.</p>
---

**Figure 1.** Question 18 of the DCI testing students' understanding of an impact.

**Question 20**

A wooden block *A* is released from rest, slides down the incline and hits an *identical* wooden block *B* at the bottom. After impact, the blocks do not stick together and both have non-zero speed. The surface on which the blocks slide is frictionless. After they separate, how far up the second hill will block *B* travel?



(a) Block *B* will stop somewhere on the horizontal section.

(b) Block *B* will go higher than the initial height of block *A*.

(c) Block *B* will go exactly the same height as where block *A* started.

(d) Block *B* will go to a lower height than the original height of Block *A*, then start sliding back down the hill.

(e) Impossible to tell without knowing the mass of the two blocks.

**Figure 2.** Question 20 of the DCI testing students' understanding of an impact.

**Table 2.** Pre and post DCI scores for MEA and non-MEA participants considering only the DCI questions directly related to MEA topic (questions 18 and 20).

	DCI Question Number	Mean DCI Pre Score [%]	Mean DCI Post Score [%]	Normalized Gain [%]	Average Normalized Gain [%]
MEA in Coursework	Q 18	26.7	45.6	25.74	41.1
	Q 20	47.6	77.2	56.48	
No MEA's in Coursework	Q 18	19.1	32.2	16.18	14.8
	Q 20	50.9	57.5	13.37	

Students in the AL sections who completed the Accident Reconstruction MEA in their dynamics course showed an average normalized gain of 41.1% improvement in their scores on the DCI questions relating to impact. These same students showed an average normalized gain of 29.4% on all remaining DCI questions which were not related to the MEA. Students in the Tr sections who did not complete the accident reconstruction MEA showed only a 14.8% normalized gain on the same DCI questions relating to impact. The same group of students showed an average normalized gain of 19.3% on all remaining DCI questions. These results show that the students who completed the MEA had a 25% higher normalized gain on the DCI questions relating to the MEA than on all other DCI questions. This is significantly different from the group of students who did not complete the MEA and showed a 25% lower normalized gain on the DCI questions relating to the MEA than on all other DCI questions.

### Results: Comparison between Post DCI Scores and Final Exam Scores

The final exam for the dynamics course was made up of five questions. Questions 1-4 were typical procedural type questions which were based off of the following topics respectively: rigid body kinematics, particle work energy and kinetics, rigid body kinetics, rigid body work energy and angular impulse momentum. Question 5 was comprised of a series of conceptual type questions which could be compared to the content of the DCI. The final exam scores were

evaluated in three ways as shown in Table 3: total exam score (%), conceptual portion of exam score (%), and procedural portion of exam score (%).

The data in Table 3 show the grade breakdown for the 154 AL students taught by two separate professors during the same quarter, both of which incorporated MEA's into their coursework. The results were broken into four categories based on the student's score on the post DCI test: 0%-25% correct, 25%-50% correct, 50%-75% correct, or 75%-100% correct. The final exam results were then analyzed overall and within each category.

**Table 3.** Post DCI scores compared to final exam scores.

	N	Value	Total Final Exam Score [%]	Conceptual Portion of Final Exam Score [%]	Procedural Portion of Final Exam Score [%]
<b>0% - 25% on Post DCI</b>	8	Mean	67.52	58.57	69.76
		Median	67.33	60.00	70.83
		St. Deviation	12.09	16.37	13.36
<b>25% - 50% on Post DCI</b>	72	Mean	64.17	63.80	64.26
		Median	63.33	66.67	62.92
		St. Deviation	12.48	15.14	14.39
<b>50% - 75% on Post DCI</b>	56	Mean	74.61	75.60	74.36
		Median	76.33	76.67	74.58
		St. Deviation	12.42	11.96	14.93
<b>75% - 100% on Post DCI</b>	18	Mean	82.15	87.22	80.88
		Median	85.00	88.33	85.00
		St. Deviation	13.48	7.25	16.64

A trend can be seen between conceptual scores on the final exam and post DCI scores. On average, students who scored high on the post DCI also scored high on the conceptual portion of the final exam. Additionally, the same trend can be seen between post DCI scores and procedural final exam scores, as well as between post DCI scores and total final exam scores. Due to these multiple trends, these data alone cannot support any type of relationship purely between post DCI scores and conceptual final exam scores.

However, by looking at a linear regression involving each of the comparisons previously described, a stronger correlation can be seen between post DCI score and conceptual exam exists than between any other combination of scores. The linear regression results are summarized in Table 4.

**Table 4.** Linear regression results from post DCI and final exam scores.

Score Comparison	Correlation Coefficient
Post DCI - conceptual final exam	0.576
Post DCI - procedural final exam	0.353
Conceptual final exam - procedural final exam	0.313

The correlation coefficient between post DCI scores and conceptual final exam scores suggests medium correlation strength between the two scores. This is higher than the resulting correlation between post DCI scores and procedural final exam scores as expected, since the DCI is intended to test only conceptual knowledge. The typical assumption that the top students will excel in all areas, in both procedural and conceptual areas in this case, is not supported by these correlations. A much higher correlation than the resulting 0.313 would be required in order to claim that students tend to do well in all areas or no areas. This suggests that there may be a level of independence between student's gain in conceptual knowledge and their gain in procedural knowledge in a course.

### **Possible Further Research**

To further develop this research, more DCI scores as well as corresponding final exam scores must be collected. The use of MEA's at California Polytechnic State Universities will also be continued in introductory dynamics, intermediate dynamics, thermodynamics and heat transfer courses. With this additional data, similar analyses can be preformed to verify and expand results.

### **Conclusion**

As would be expected, there was a strong correlation between the DCI scores and the conceptual scores on the final exam. We would also have expected a strong correlation between the procedural and conceptual scores; students who do well on problem solving should also have a strong grasp of dynamics concepts. This correlation, however, was much weaker. Future studies could also examine if students who did well on certain conceptual problems (eg. work-energy) needed that conceptual understanding to complete their corresponding procedural exam problems.

Without further investigation, the results remain ambiguous as to whether or not a correlation exists between procedural and conceptual knowledge. It appears from the data that conceptual and procedural knowledge may have separate developments paths but further research is required to gain more insight before a concrete conclusion may be reached.

### **References**

- [1] Johnson, Bethany, Robert Siegler, Martha Alibali. "Developing Conceptual Understanding and Procedural Skill in Mathematics: An Interactive Process ." Journal of Educational Psychology 93(2001): 346-362.
- [2] Streveler, Ruth, Thomas Litzinger, Ronald Miller, Paul Steif. "Learning Conceptual Knowledge in the Engineering Sciences: Overview and Future Research Directions." Journal of Engineering education (2008): 279-294.
- [3] Hake, R. R. "Interactive-Engagement Versus Traditional Methods: A Six-Thousand-Student Survey of Mechanics Test Data for Introductory Physics Courses," American Journal of Physics, 66(1998), pp. 64–74.



- [4] Self, Brian, Ronald Miller, Andrew Kean, Tamara Moore, Teresa Ogletree, Frank Schreiber (2008), "Important Student Misconceptions in Mechanics and Thermal Science: Identification Using Model-Eliciting Activities." ASEE/IEEE Frontiers in Education Conference.
- [5] Johnson, Bethany, Martha Alibali. "Conceptual and Procedural Knowledge of Mathematics: Does One Lead to the Other?" Journal of Educational Psychology 91(1999): 175-189.
- [6] Hestenes, David, Malcolm Wells, Gregg Swackhamer. "Force Concept Inventory." The Physics Teacher 30(1992): 141-158.
- [7] Gray, Gary, Costanzo Francesco, Don Evans, Phillip Cornwell, Brian Self, Jill Lane (2005), "The Dynamics Concept Inventory Assessment Test: A Progress Report and Some Results." Proceedings of the 2005 American Society for Engineering Education Annual Conference & Exposition.
- [8] Hamilton, Eric, Richard Lesh, Frank Lester, Michael Brilleslyper. "Model-Eliciting Activities (MEAs) as a Bridge Between Engineering Education Research and Mathematics Education Research." Advances in Engineering Education A Journal of Engineering Education Applications, Summer 2008. American Society for Engineering Education. 10 Feb 2009 <<http://advances.asee.org/vol01/issue02/06.cfm>>.

### **Acknowledgements**

This work was funded by the NSF CCLI Grant #070607: *Collaborative Research: Improving Engineering Students' Learning Strategies Through Models and Modeling*.

### **Author Information**

#### **Brian Self, California Polytechnic State University**

Brian Self has been an Associate Professor at Cal Poly for the last three years. Before that, he taught at the Air Force Academy for seven years. He is the ASEE Campus Rep and the Zone IV Chair. Besides his pedagogical research, Dr Self is actively involved in aerospace physiology and biomechanics research. He has worked extensively to involve undergraduates in his research, taking students to present at national and international conferences. By involving students in solving ill-defined projects and problems that don't have a "correct answer", Dr Self hopes to further advance their intellectual curiosity and problem solving skills.

#### **James Widmann, California Polytechnic State University**

Jim Widmann is an Associate Professor of Mechanical Engineering at California Polytechnic State University, San Luis Obispo. He received his Ph.D. in 1994 from Stanford University. Currently he teaches mechanics and design courses. He conducts research in the areas of design optimization, machine design, fluid power control and engineering education.

#### **Lora Goodwin, California Polytechnic State University**

Lora Goodwin is an undergraduate mechanical engineering student at California Polytechnic State University, San Luis Obispo. Her interests lie in the fields of math and science. She plans to complete her graduate work in mathematics in order to teach math at the college level.

# Teaching Classical Control to Mechanical Engineers via Take-Home Experimental Setup Based on Microcontrollers

Vasco D. Polyzoev, Eniko T. Enikov

Advanced Micro and Nano Systems Laboratory, Department of Aerospace and Mechanical Engineering, The University of Arizona

## I. Introduction

Supplementing a control systems class with a hands-on experience for students by working on a real dynamical system helps in better understanding the classical control theory and emphasizes the importance of its applications. For a small size class this could be achieved by developing laboratory setups with various experiments that students can perform in groups taking turns. Many universities have already added a laboratory to their programs and have reported the beneficial effect of that for the students [3, 4]. In most cases they rely on commercially available laboratory setups [5]. Even then, finding suitable times that can accommodate all students might be difficult and it brings the necessity of a room and an instructor for the sessions. Solutions for those problems have been proposed by utilizing remote access laboratories via the Internet [6]. However, this would require additional equipment for remote access and still keeps the need for a specific room.

At the Aerospace and Mechanical Engineering Department of The University of Arizona, it is not unusual for the Control System Design course to have enrollment of about 100 students. This makes offering a lab section with the course nearly impossible. As a way to avoid canceling the practical experience of the course, we developed an inexpensive and portable setup, which can be taken home by the students, and they can work on it as their term project. Besides addressing our organizational problems, this solution brought an opportunity to demonstrate to students a modern approach towards control systems using computers and implementing the controller in software.

## II. Experimental setup description

The setup consists of a small DC electrical motor, operating at 0-5V, attached to one of the ends of a light carbon rod. The other end of the rod is attached to an extension of the shaft of a low-friction potentiometer. The potentiometer is fixed on a plastic stand at the proper height, so that the pendulum can swing freely. A 2" propeller U-80 is attached to the motor shaft to produce a thrust force in order to control the angular displacement of the pendulum from the vertical position (fig. 1). A custom designed circuit board produces the controlled voltage supply for the motor via Pulse-Width Modulation (PWM) with a resolution of 0.05V, and reads out the voltage on the potentiometer, which is proportional to the angular position of the pendulum. These functions are implemented using a Microchip PIC16F690 microcontroller, mounted on a ZIF socket for convenient replacement in case of damage or reprogramming of firmware if needed (fig. 2). The microcontroller communicates with a PC through its serial port using RS-232 protocol and a Maxim MAX232 driver/receiver. It sends to the PC the value of the potentiometer voltage, measured by the built-in Analog-to-Digital Converter (ADC), and receives the

computed control signal and converts it to the respective PWM output for the motor. The PWM output is passed to an H-bridge configuration of MOS transistors, which produces the necessary current for the motor and allows bi-directional motor control [1, 2].

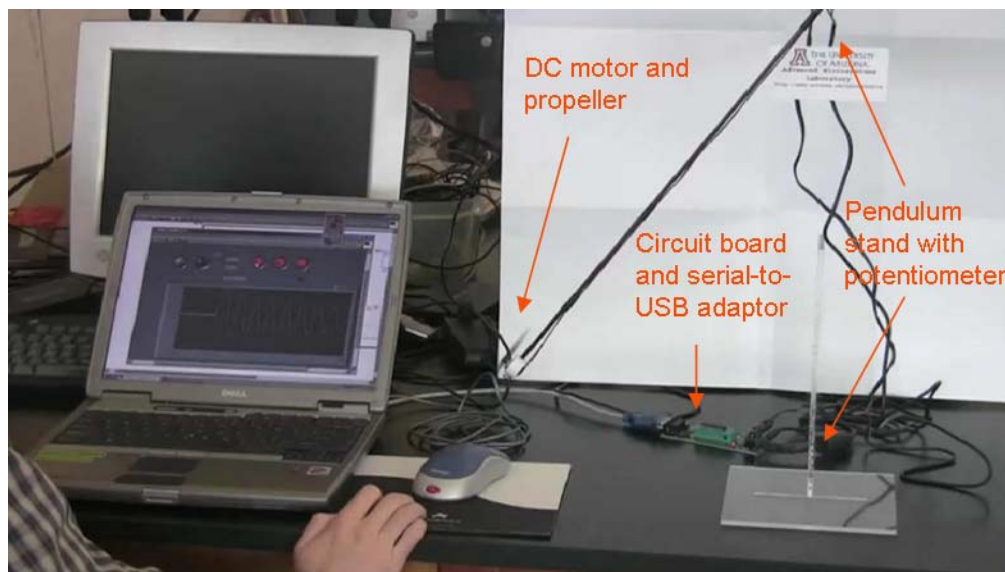


Fig. 1: Overview of the DC motor pendulum setup



Fig. 2: Circuit board controlling the motor and reading the potentiometer voltage

A MATLAB program running on the PC receives the potentiometer voltage and computes the angular position of the pendulum from it. Then, the program either sends a constant control signal, in case of an open loop run, or computes and sends a proportional control signal in the case of a closed loop run of the experiment. It also plots in a figure on the computer screen the value of the displacement angle vs. time (fig. 3). A software module based on LabVIEW is also

developed, to make the setup usable with this environment for educational institutions that have license for it only. More information could be found in [7].

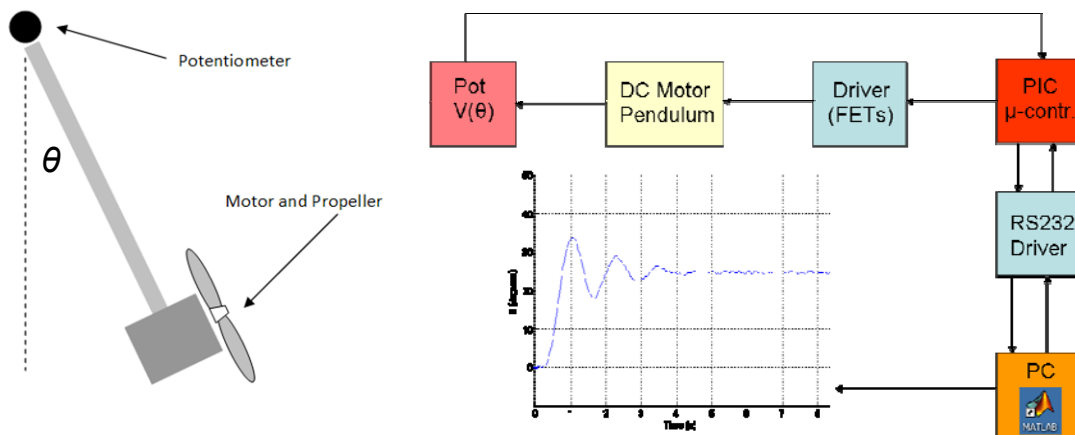


Fig. 3: Sketch and block-diagram of the setup

### III. Project assignment description

The students develop a full (non-linear) mathematical model of the system and identify its physical parameters (the values of  $u_0$  and  $K/mg$  on fig. 5). The latter are extracted using the open loop response of the system, illustrated in fig. 4. The system allows demonstration of non-linear effects occurring in the DC motor (due to dry friction) illustrated in fig. 5, and in the equations of motion of the pendulum (the sine term). Over the course of this experiment, the students also apply the method of feedback linearization by removing the sine term from the equations of motion of the pendulum (by including it in the computed control signal).

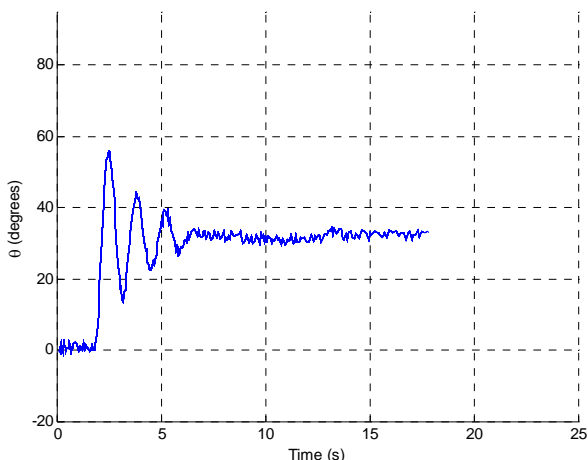


Fig. 4: Open loop response

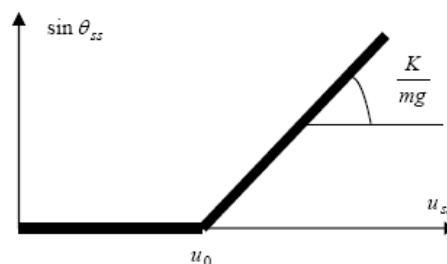


Fig. 5: Sine of the steady-state displacement angle vs. motor voltage

For the linearized closed-loop system, students are asked to determine how well it matches the theoretical predictions for steady-state error (based on the system type), disturbance rejection, and stability (based on the root locus of the system). Disturbance rejection properties are demonstrated in the closed loop response in fig. 6.

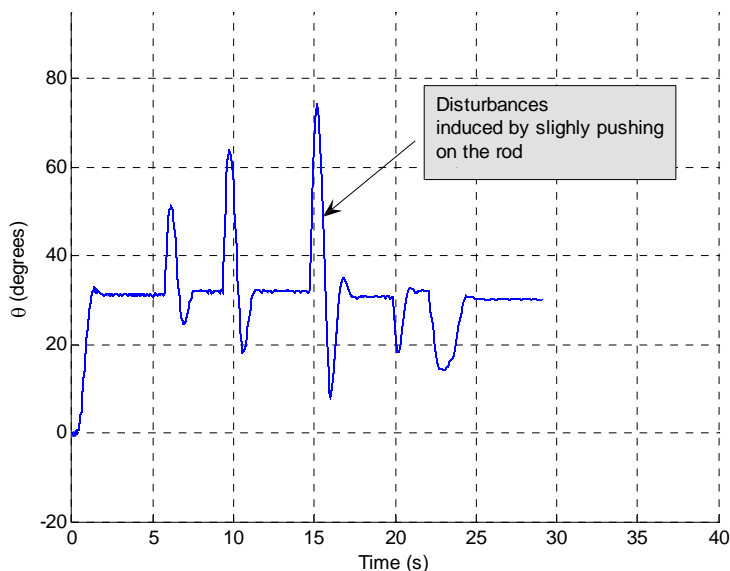


Fig. 6: Closed loop response

#### IV. Student experience assessment

During this semester, a paper-based project was also offered. A total of 72 students selected the hardware-based project, and 27 chose the paper-based one. An anonymous survey was conducted for the students choosing the hardware-based project, to share their experience after the first semester this project setup was offered in the Control System Design course, following the protocol approved by the Institutional Review Board. A total of 26 students participated and Table 1 shows the evaluation of technical contents of the project.

Table 1

To what extent (how well) did the project illustrate the following technical concepts?					
	Not at all	Less than expected	More than expected	Very well	Rating Average
Relation between physical system and transfer function	0.0% (0)	15.4% (4)	<b>50.0% (13)</b>	34.6% (9)	3.19
Second-order system response	0.0% (0)	15.4% (4)	<b>53.8% (14)</b>	30.8% (8)	3.15
Relationship between stability and gain	0.0% (0)	11.5% (3)	<b>46.2% (12)</b>	42.3% (11)	3.31

Table 1, cont.

To what extent (how well) did the project illustrate the following technical concepts?					
	Not at all	Less than expected	More than expected	Very well	Rating Average
Relationship between overshoot and gain	0.0% (0)	30.8% (8)	<b>42.3% (11)</b>	26.9% (7)	2.96
Use of root locus	0.0% (0)	38.5% (10)	<b>42.3% (11)</b>	19.2% (5)	2.81
Use of Bode plots	<b>50.0% (13)</b>	26.9% (7)	19.2% (5)	3.8% (1)	1.77
System type and steady-state error	0.0% (0)	19.2% (5)	<b>57.7% (15)</b>	23.1% (6)	3.04
Disturbance rejection and system recovery	0.0% (0)	30.8% (8)	<b>53.8% (14)</b>	15.4% (4)	2.85
Non-linearity and ways to deal with it	0.0% (0)	<b>42.3% (11)</b>	30.8% (8)	26.9% (7)	2.85
Effects of time delay	0.0% (0)	38.5% (10)	<b>46.2% (12)</b>	15.4% (4)	2.77

In a second part of the survey, we asked the students why they had chosen the hardware project over the paper-based one. The majority of them were excited by seeing the effect of the application of control theory to a tangible system. They were also interested in establishing a connection between the calculations and the experimental results. Here are some quotes of the actual answers: "I was excited about the idea of actually seeing this design work on paper get implemented into a tangible mechanism. It was very motivating. It answered the timeless questions, "Why do we need to know this? What is it good for?"; "The hardware project offered a more real-world physical representation of control system design."; "I like to be hands-on, I learn more from doing things with my hands."; "It seemed more interesting to be able to apply the topic to a physical system rather than a theoretical controller design."

To the question where did the students do their experiments with the setup (how portable it is), most of the answers were at home or at the university computer labs. The need for lab or assistance during the project was assessed by the students participating in the survey in the following categories shown in table 2:

Table 2

Did not need a physical lab at all, I could do everything myself	56 %
Had to use the TA a bit, but 1 hr per week was enough	32 %
I needed to ask for additional assistance outside the 1 hr/week from the TA/instructor	8 %
The project should be done in a permanent lab with fixed operating hours and TA-s	4 %

## V. Conclusion

An inexpensive (less than \$100) take-home experimental setup has been designed for a hands-on experience of mechanical engineering students with a real control system. This makes it suitable for a term project, where minimal or no supervision is required, and no special time or place is needed. It also helps students whose major is not electrical engineering to become familiar with the modern developments in implementation of real-time control systems.

## Acknowledgements:

The authors acknowledge the financial support of the National Science Foundation under Grant Nos. 0633312 and 0637052.

## References:

- [1] M. Rylee, "Low-Cost Bidirectional Brushed DC Motor Control Using the PIC16F684", AN893, Microchip Technology Inc.
- [2] J. Julichter, "RC Model Aircraft Motor Control", AN847, Microchip Technology Inc.
- [3] C. Chandrasekara, A. Davari, "Control Experimentation for Undergraduate Students", 2005 American Control Conference, June 8-10, 2005. Portland, OR, pp. 5156 – 5161
- [4] <http://maeweb.ucsd.edu/~ugcl/>, The Undergraduate Control Laboratory at the department of Mechanical and Aerospace Engineering, University of California, San Diego
- [5] <http://www.ecpsystems.com/>, Educational Control Products, Bell Canyon, CA
- [6] B. A. Foss, T. I. Eikaas, M. Hovd, "Merging physical experiments back into the learning arena", Proceedings of the American Control Conference, Chicago, Illinois, June 2000, pp. 2944 – 2948
- [7] <http://www.nano.arizona.edu/mechatronics>, The Control Systems Project website of the Aerospace and Mechanical Engineering department of the University of Arizona

## Using Model Eliciting Activities in a Dynamics Course

Teresa M. Ogletree, Brian P. Self, and James Widmann

California Polytechnic State University  
San Luis Obispo

### Abstract

Typical assignments in a traditional dynamics course often do little to motivate students or to give them an indication of how they would use the material in a future job situation. Many instructors are now attempting to provide motivational projects, hands-on demonstrations, and even laboratory assignments to increase understanding and motivation. To help provide motivation and real-world context in our dynamics courses at California Polytechnic State University San Luis Obispo, we have implemented three model-eliciting activities (MEA). Model-eliciting activities (MEAs) originated in the math education community. They focus on the process of problem solving and model development, rather than just a final answer.

The first MEA requires students to create an Accident Reconstruction Procedure for police officers in Sri Lanka. The student teams were given four accident reports, some pulled from actual police reports, to analyze and use in determining their procedures. They had to utilize work-energy and momentum principles as guidelines, in addition to accounting for uncertainty and other noise in the data. Their Model Documentation was in the form of a memo to the Sri Lankan Police Chief, along with their analysis of the four accidents.

The customer for the second MEA is a publishing company of dynamics textbooks. The student teams had to develop guidelines to send to potential developers of online multimedia example problems. Their "Engineering Consulting Firms" then had to develop one of these multimedia examples according to their guidelines. The final MEA involves a physical experiment in which students have the opportunity test the validity of their work. The student teams are asked to analyze a catapult to help with an historical battle re-enactment in England.

### Background to Model Eliciting Activities

MEAs, also called Thought Revealing Activities, were first developed in the mid 1970s to serve as a tool for understanding the problem solving thought processes of children studying mathematics [2]. Rather than pushing students toward a particular solution, MEAs focus on the development of an adaptive problem solving strategy or model that can be repeatedly used. The originators of MEAs propose six primary principles to develop new problems [1].

- 1) The Model-Construction Principle requires that the students come up with a procedure for explaining a "mathematically significant" situation.
- 2) The Reality Principle puts the problem in context and offers a client who needs a realistic engineering solution to a problem.
- 3) The Self-Assessment Principle enables students to analyze their problem solutions and revise their approach to open ended problems.



- 4) The Model Documentation Principle teaches students to create a mental model of their process in solving the problem. Documentation of their model and solution is often in the form of a memo to the client.
- 5) The Generalizability Principle asks students to develop models that other students (and the client) could easily use, and models that can be adapted to other similar situations.
- 6) The Effective Prototype Principle states that the concepts students must formulate, construct, and modify must be robust in terms of their applicability to the future academic and professional life of the engineering students.

MEAs have since been adapted for use in the engineering sciences as a way of introducing students to the types of open-ended scenarios that will be encountered outside of an academic setting in a job environment [3]. This is thought to provide a more motivating and memorable experience for students in place of doing a multitude of redundant textbook problems. Additionally, MEA's are used to help in identification and repair of student misconceptions in mechanics and thermal science [4].

Cal Poly San Luis Obispo has been involved in the collaborative research effort of incorporating MEAs into the mechanical engineering coursework since September 2007, and has since implemented MEAs in both thermodynamics and dynamics courses. We also currently have plans to expand the use of MEAs to other areas of the mechanical engineering curriculum.

The three MEAs that have already been implemented in the dynamics courses each provide a real-world context for doing dynamics work. They are intended to help incite motivation and stimulate model building thought. For each MEA, a small team of students was asked to develop a model or set of guidelines using dynamics principles in response to a client's specific needs. Students were also asked to document their model, either in a memo or short report, and provide one or two examples of how the model is utilized. At the end of the academic quarter, the dynamics students that took the MEAs were asked to complete a comprehensive survey that included questions about whether each project motivated them to participate in class and if the MEAs helped them learn material regarding the class.

### **Accident Reconstruction MEA**

The first MEA implemented in the course involved creating a procedure for investigating traffic accidents where one party was potentially speeding. In order to provide a meaningful social context for the scenario, the problem statement was presented in the form of a memo from the Inspector General of the Sri Lanka Police Service who is looking to both expand and modernize his department. Included with the memo were four sample accident case reports that the student teams used to develop their model. Some of the case reports were adapted from actual reports provided by the Oceanside Police Department, in Oceanside California, which added a unique level of both realism and ambiguity to the project. The remaining reports were fabricated to mirror the authentic reports provided by the police department, and were written utilizing similar language and formatting. Table I below outlines how the Accident Reconstruction MEA meets each of the six primary principles.

TABLE I  
THE ACCIDENT RECONSTRUCTION MEA DESIGN PRINCIPLES

MEA Design Principles	How the Accident Reconstruction MEA meets the design principle
Model Construction	Each team will produce a protocol to provide to new traffic investigators based on the solutions of several accidents.
Reality	Dynamics calculations in accident reconstruction are an essential part of forensic engineering. Additionally, the social context of the expanding Sri Lanka Police Service is an actual current event.
Self-Assessment	The provided case reports are intended to be a way in which students can test their model. Because most of the cases are actual incident reports, courtesy of the Oceanside Police Department, conclusions can be compared to those of the investigating officers.
Model Documentation	Teams will write a memo explaining their method for accident analysis. Included with the memo will be a written protocol that an officer can use at the scene and the conclusions of their analysis of each provided incident report.
Generalizability	The model that students will create must be usable for all of the provided incident reports. It should also be able to be easily adapted for analyzing other traffic accidents.
Effective Prototype	Formulating a model requires students to utilize principles of work-energy and momentum, which will be encountered in future academic and professional work. The MEA also requires them to work with energy lost in an inelastic collision in the form of vehicle crush constants

The MEA was presented to students in the third week of instruction, after students were introduced to the concepts of work-energy and collision momentum. Teams of four were given one week to complete the project, during which they were allowed to email their professor for some select additional information not provided in the MEA, such as coefficient of friction values, posted speed limits and vehicle crush constants.

Overall, students enjoyed the MEA. End of the year survey data showed that 60% of students agreed that the project helped them learn the principles of work-energy and momentum, 9% of which felt strongly about the results. Additionally, 61% of the students surveyed felt that the project was interesting and motivating. Most of the students seemed engaged by working on a problem that related to a realistic setting; those who were not, appeared to be detoured by the open-endedness and uncertainty associated with the case reports.

### **Multimedia Example MEA**

The second MEA was not necessarily designed to focus on any particular dynamics topic, but rather to gain more insight into what students think is important for effectively learning from an example problem. In the MEA, they were asked by a textbook publisher to create specific guidelines for dynamics professors that can be used to develop online multimedia example problems for a dynamics class. Throughout the course, students were required to view several

interactive online example problems prior to coming to class, and most had already had exposure to other online examples available from several textbook publishers. The following table lists the MEA's adherence to the six principles.

TABLE II  
THE ONLINE MULTIMEDIA MEA DESIGN PRINCIPLES

MEA Design Principles	How the Online Multimedia MEA meets the design principle
Model Construction	Each student team must develop specific guidelines for creating dynamics example problems, including one sample example problem made using these guidelines
Reality	Textbook publishers are more frequently offering some sort of online multimedia support for their books. Most students have already had experience with textbook support sites.
Self-Assessment	By creating a sample dynamics example problem students are able to test if their guidelines work in practice.
Model Documentation	Teams will write a memo to the client with their guidelines for professors to use along with the sample problem.
Generalizability	The guidelines that students will create should be capable of being used for developing example problems for any of the concepts covered in a typical dynamics course.
Effective Prototype	The models students create should help them conceptualize their own thought processes when reviewing example problems and will aid them in their continued education.

The Multimedia MEA was presented to students in the sixth week of classes. As with the Accident Reconstruction MEA, students worked in teams of four and were given one week to complete the assignment, which they later presented in class.

Student feedback for this project was mixed. 36% of students responded that the project helped them understand the dynamics material, while 30% disagreed; the remaining 34% had no opinion either way. Responses about project motivation had similar results, with 39% of students feeling that the project was motivating and 40% disagreeing. While the MEA required students to focus on developing a thought process for explaining a problem, it is possible that they spent too much time concerned about the aesthetics of their example rather than honing their model. To eliminate this, we have limited the example to one rigid body dynamics problem and are providing specific instructions on how do the online examples in PPT.

### **Catapult Design MEA**

The last MEA asked students to create a procedure for determining the launch settings of a catapult given a specific target distance. The client for this MEA was the Peterborough, England City Council, who sponsors an annual interactive medieval exhibition at the Peterborough Museum Art Gallery. The actual event currently includes a trebuchet competition in which participants build and fire their own trebuchets. In lieu of this, the MEA presented the scenario that the City Council desired to expand the event to include a catapult demonstration. Students

were given the opportunity to take dimension measurements from one of several mini catapults, seen in figure 1 below, and a digital force gage was used to acquire the rubber band tension at varying lengths. The procedures that students were required to create needed to account for varied settings such as pin locations and pull-back angle, and to explain possible sources of error. Finally, students were allowed to test their model's ability to predict the projectile's distance by firing raw eggs at a picture of their professor (for a fun hands-on experience). Table III below shows how the six MEA principles are met by the project.



**Figure 1: The Statapult, designed as a Six Sigma quality management training device available for purchase online.**

TABLE III  
THE CATAPULT MEA DESIGN PRINCIPLES

MEA Design Principles	How the Catapult MEA meets the design principle
Model Construction	The student teams will produce a methodology to provide to Physics instructors, including a mathematical solution for a single catapult setting.
Reality	The Peterborough Museum Art Gallery holds an annual Medieval Machines exhibition that includes a trebuchet competition. Cal Poly has purchased several of the catapults, therefore the students can actually launch the catapults afterwards to test their calculations.
Self-Assessment	The teams will be provided data regarding maximum distances that the catapult can fly, which they can then use to test their calculations. Alternatively, they could simply be told a range of distances by which they can assess their calculations on launch day.
Model Documentation	Teams will produce a memo to the client detailing the procedure to estimate the launch distance. Sample calculations are also required. Students may choose to provide an Excel spreadsheet or other computer program to make the model more usable for the client.
Generalizability	The teams must create the model for the city council to use for a variety of different configurations. The catapult operators may want to change the number of rubber bands, the placement of the different pins, or the mass of the projectiles. The general approach may be applicable to other models of catapults (the company also makes a Trebuchet catapult).
Effective Prototype	Basic concepts of work-energy and projectile motion are used in the MEA. Students could also choose to apply concepts of angular momentum or even variations of Newton's Second Law. The teams will apply theoretical dynamics principles to a practical application that they can actually test in a hands-on "experiment".

This was the last MEA presented to students during the ninth week of the academic quarter. Again, students were placed in groups of four. They were given one week for their analysis and procedure development, and then performed testing the following week.

A total of 68% of the students thought the MEA was interesting and motivating. Additionally, 49% of students felt that the MEA helped them learn the material, 20% of that group feeling that it helped them very strongly. The main complaint that students had about this project was that it was presented too late in the quarter and they would have liked more time for completion.

## Conclusions

The MEAs utilized in the dynamics courses were all aimed at motivating students by providing realistic and interactive scenarios that were client driven, and by giving them the chance to develop higher levels of problem solving conceptualization than typical textbook problems allow. With each MEA tested valuable feedback was gained on how to better meet the

educational needs of students. In general, the two projects with more direct correlations to material covered in lecture, the Accident Reconstruction and Catapult MEAs, appeared to be more successful with students. Those who did not feel motivated by the MEAs typically cited that the scope of the projects were too large or that more time would be needed to better their models.

Future testing at Cal Poly will include expanding MEAs to statics and thermal systems design courses. Additionally, there are plans to add more incident reports to the Accident Reconstruction MEA to limit the likelihood of students dividing the four cases between them, forcing the students to operate more as a team. Moreover, this will give students a wider variety of scenarios that their procedure must be able to accommodate. There are also plans to enhance the self-assessment aspect of the Catapult MEA by instrumenting the mini catapult with strain gages and a two-axis accelerometer so that students can verify their calculations during their launches.

### **Acknowledgements**

This work was funded by the NSF CCLI Grant #070607: *Collaborative Research: Improving Engineering Students' Learning Strategies Through Models and Modeling*.

Thank you to Jennifer Kelly, Sgt. Kenneth Gow and Capt. Reginald Grisby of the Oceanside Police Department for providing case studies for the Accident Reconstruction MEA.

### **References**

- [1] Lesh, R., et al. (2000). Principles for developing thought revealing activities for students and teachers. The handbook of research design in mathematics and science education, A. Kelly and R. Lesh, Editors. Erlbaum: Mahwah, NJ.
- [2] Chamberlin, Scott A., and Sidney M. Moon. (2005). Model-Eliciting Activities as a tool to develop and identify creatively gifted mathematicians. *Journal of Secondary Gifted Education*,
- [3] Moore T.J. & Diefes-Dux, H.A. (2004). Developing Model-Eliciting Activities for undergraduate students based on advanced engineering context. 34<sup>th</sup> ASEE/IEEE Frontiers in Education Conference.
- [4] Self, Brian P., Ronald L. Miller, Andrew Kean, and Tamara J. Moore (2008). Important Student Misconceptions in Mechanics and Thermal Science: Identification Using Model-Eliciting Activities. 38<sup>th</sup> ASEE/IEEE Frontiers in Education Conference, Saratoga Springs, NY.

**Author Information****Teresa M. Ogletree**

Teresa Ogletree is an Undergraduate student at California Polytechnic State University, San Luis Obispo. She will be completing her bachelor's degree in Mechanical Engineering in March 2009.

**Brian Self, California Polytechnic State University**

Brian Self has been an Associate Professor at Cal Poly for the last three years. Before that, he taught at the Air Force Academy for seven years. He is the ASEE Campus Rep and the Zone IV Chair. Besides his pedagogical research, Dr Self is actively involved in aerospace physiology and biomechanics research. He has worked extensively to involve undergraduates in his research, taking students to present at national and international conferences. By involving students in solving ill-defined projects and problems that don't have a "correct answer", Dr Self hopes to further advance their intellectual curiosity and problem solving skills.

**James Widmann, California Polytechnic State University**

Jim Widmann is an Associate Professor of Mechanical Engineering at California Polytechnic State University, San Luis Obispo. He received his Ph.D. in 1994 from Stanford University. Currently he teaches mechanics and design courses. He conducts research in the areas of design optimization, machine design, fluid power control and engineering education.

## Appendix A: Accident Reconstruction MEA

### Memorandum

To: Forensic Engineering Team

From: H. M. B. G. Kotakadeniya, Senior Deputy Inspector General of Police,  
Sri Lanka Police Service

RE: Traffic Accident Reconstruction Protocol

Priority: [Urgent]



Since 2003 your country has been making large aid efforts toward development and economic stabilization here in Sri Lanka. Relations have gotten even closer with the invaluable help we received following the devastating tsunami in 2004. As a result, we have been able to become an important figure in the fight against terror in South-Central Asia.

As you may already know, the Sri Lanka Police Service has recently launched a new programme to update and modernize the service we provide to the public. One key area for improvement is in the Traffic Police Division. This division was established in 1953 to assist in making decisions on traffic policies and implementing them. Every currently existing station maintains a traffic branch, but the growing number of drivers on the island and the intended building of new stations demand that we immediately improve our accident investigation protocol. I am charging you with the task of compiling a new set of forensic engineering guidelines that can be used to train new police officers.

At the moment the main focus of this development must be in developing a procedure for determining if a driver has violated the speed limit. This procedure should use engineering principles to carefully guide our new investigators through the process of determining whether the driver in question has indeed caused the accident by speeding. I would like your team to submit a report to me detailing this new protocol for review. In this report be sure to include your opinions and conclusion for each accident report.

To aid you in this process my officers will provide you with a set of abridged incident reports that are characteristic of typical accident we regularly investigate. However, for legal reasons sections of the reports have been omitted and the names of those involved have been replaced. In each report you will find a general description of the accident followed by more detailed information pertaining to possibly relevant parameters in the accident. Additional information regarding friction coefficients and impact crush constants can be provided upon request.

I am confident that your team will exceed our expectations.

H. M. B. G. Kotakadeniya

Attachments: Case Files 06\_015741  
06\_017742  
06\_014874  
07-000863



**Table 1.** Typical Frictional Coefficients of Automobile Tires on Various Surfaces

gravel and dirt road	0.35
wet grassy field	0.20
dry asphalt	0.60
wet asphalt	0.45
snow-covered road	0.20-0.30
Ice	0.05-0.10
dry concrete	0.70
wet concrete	0.60
Steel on dry asphalt	0.14

**Table 16.6** Small Cars Stiffness Coefficients

Vehicle	Weight (lb)	Stiffness Coefficient (lb-ft/in)
1979 Honda Civic	2180	4720
1979 Ford Fiesta	2190	4040
1979 Plymouth Champ	2310	4260
1979 Datsun 210	2430	3960
1979 VW Rabbit	2600	4860
1982 Toyota Corolla	2650	5340
1979 Chevette	2730	5150
Average	2441	4619
Range	+12/-11%	+16/-14%

Note: Data from *Fseld Accidents. Data Collection. Analysts. Methodologies and Crash Injury Reconstruction*. 1985. paper 850437, "Barrier Equivalent Velocity, Delta-V and CRASH3 Stiffness in Automobile Collisions" by Hight, Hight, and Lent-Koop. Figure 16.4.

**Table 16.7** Medium Cars Stiffness Coefficients

Vehicle	Weight (lb.)	Stiffness Coefficient (lb-ft/in)
1979 Mustang	3070	7610
1979 Mercury Capri	3070	7178
1979 Chevrolet <i>Monra</i>	3240	5970
1979 Volvo 242	3290	4600
1979 Ford Fairmont	3300	6000
1982 Volvo DL	3350	5040
1979 Volvo 244DL	3370	4960
Average	3241	5908
Range	+4/-5%	+28/-22%

Note: Data from *Field Accidents. Data Collection. Analysts, Methodoloies and Crash Injury Reconstruction*. 1985. paper 850437, "Barrier Equivalent Velocity, Delta-V and CRASH3 Stiffness in Automobile Collisions" by Hight, Hight, and Lent-Koop. Figure 16.4.

**Table 16.8** Full Sized Cars Stiffness Coefficients

Vehicle	Weight (lb)	Stiffness Coefficient (lb-ft/in)
1980 AMC Concord	3700	7460
1979 Plymouth Volare	3820	7170
1979 Old Cutlass	3820	5600
1979 BMW 528	3840	6400
1979 Ford Granada	3950	6145
1979 Mercury Marquis	4220	6300
1979 Ford LTD	4370	6850
1979 Dodge St. Regis	4460	6470
1979 Olds Regency	4710	7355
1979 Ford LTD II	4810	6000
1979 Lincoln Continental	5360	7384
Average	4278	6649
Range	+25/-14%	+12/-16%

Now Data (from *Field Accidents. Data Collection. Analysis. Methodologies and Crash Injury Reconstruction*. 1985. paper 850437. "Ramer Equivalent Velocity, Delta-V and CRASH3 Stiffness in Automobile Collisions by Hight, Hight, and Lent-Koop. Figure 16.4.

## SRI LANKA POLICE DEPARTMENT MAJOR ACCIDENT INVESTIGATION TEAM

DATE OF INCIDENT	TIME	NCIC NUMBER	OFFICER I.D.	NUMBER
April 29, 2006	0422	3710	1120	06-015741

**INTRODUCTION**

This traffic collision occurred on Saturday April 29, 2006, at approximately 0422 hours. This traffic collision occurred on Pallamadu Rd, within the City of Colombo.

The collision involved a 1994 white Ford Explorer driven by [REDACTED], henceforth referred to as Driver A.

The Ford was traveling northbound on Pallamadu Rd in the number one lane of travel at an unknown speed when the driver somehow lost control of the vehicle. The truck rolled over onto its top side in the number 2 lane of travel and proceeded to skid 255 feet on the asphalt roadway.

Driver A received minor injuries to the arms and head by broken glass and was treated on the scene by emergency personnel.

Released Per  
Public Records  
Act Request

**SCENE :**

Section omitted.

**Weather Condition**

The following weather conditions were noted at Colombo Airport. The airport is located about ¼ mile from the scene.

Time	Temperature	Dew Point	Humidity	Pressure	Visibility	Wind	Conditions
0352	66.8° F	64.7° F	81%	29.95 in	8 miles	Calm	Clear
0452	66.2° F	64.3° F	83%	29.96 in	8 miles	Calm	Clear
0552	65.7° F	60.2° F	92%	29.95 in	8 miles	3.2 mph NNW	Clear

**Traffic Control**

The posted speed for the road in the area of this collision is 45 mph. The speed limit is clearly posted for both sides with Type R 45 MPH speed limit signs. The speed limit was established by a traffic engineering and speed survey.

MALT PREPARER'S NAME	I.D. NUMBER	DATE	REVIEWER'S NAME	DATE
A. Ahubudu	1120	4/29/06		

## SRI LANKA POLICE DEPARTMENT MAJOR ACCIDENT INVESTIGATION TEAM

DATE OF INCIDENT	TIME	NCIC NUMBER	OFFICER I.D.	NUMBER
April 29, 2006	0422	3710	1120	06-015741

**VEHICLES****Vehicle One (1994 Ford Ranger)****Description**

Year: 1994  
 Make: Ford  
 Model: Explorer  
 License: [REDACTED]  
 VIN: [REDACTED]  
 Engine: 1.5L V4  
 Transmission: 5 speed Manual  
 Color: White  
 Type: 2 door  
 Weight: 4580 pounds  
 Length: 174.5 inches (4673 mm)  
 Height: 67.5 inches (1714 mm)  
 Width: 70.2 inches (1778 mm)  
 Center of gravity: 24.1 inches (height)

**Damage Description:****Front:**

Minor to moderate damage was sustained to the front right portion of V1.

**Right**

Minor to moderate damage was sustained to this portion of V1. This damage consisted of scrapings where V1 was in contact with the road and broken side windows.

**Left**

I did not observed any damage to this portion of V1.

**Rear**

I did not observed any damage to this portion of V1.

**Roof**

Moderate damage was sustained to the roof of V1 but the average height of V1 remained unchanged.

MALT PREPARER'S NAME	I.D. NUMBER	DATE	REVIEWER'S NAME	DATE
A. Ahubudu	1120	4/29/06		

## SRI LANKA POLICE DEPARTMENT MAJOR ACCIDENT INVESTIGATION TEAM

DATE OF INCIDENT	TIME	NCIC NUMBER	OFFICER I.D.	NUMBER
June 20, 2006	0518	3710	1120	06-017742

**INTRODUCTION**

This traffic collision occurred on Friday June 20, 2006, at approximately 0518 hours. This traffic collision occurred on Jawatte Rd, within the City of Colombo.

The collision involved a 1999 red Nissan Super Saloon driven by [REDACTED], and a 1994 black Ford Fiesta driven by [REDACTED].

The Nissan was traveling northbound on Jawatte Rd up a 7% grade. As the Nissan reached the top of the grade it collided head on with the Ford which was traveling southbound. The road north of the collision point, on which the Ford had been traveling, had a 0% grade. After impact, both vehicles slid together with locked wheels 5.8 meters down the hill.

Prior to the accident, about 3.2 kilometers south of the scene, an officer on patrol observed that the Nissan was traveling approximately 16 -24 km/h. The officer then left to respond to another incident on Kelaniya Rd.

Physical evidence at the scene indicated that the driver of the Ford was aware that he was about to impact Nissan. Wheel locked skid marks just prior to the collision were measured to be 9.4 meters in length and matched the tire pattern of the Ford. Roadway conditions at the time of the accident were slightly wet.

The driver of the Nissan was killed instantly. The driver of the Ford was transported via ambulance to Colombo Hospital received for treatment, then died later from his injuries.

**SCENE :**

Section omitted.

**Weather Condition**

The following weather conditions were noted at Colombo Airport. The airport is located about 3.2 km from the scene.

Time	Temperature	Dew Point	Humidity	Pressure	Visibility	Wind	Conditions
0452	19.3° C	18.2° C	81%	760.7 mm H <sub>2</sub> O	12.9 km	Calm	Light Rain
0552	16.8° C	17.9° C	83%	761.0 mm H <sub>2</sub> O	12.9 km	Calm	Foggy
0652	18.7° C	15.7° C	92%	760.7 mm H <sub>2</sub> O	12.9 km	5.1 km/h NNW	Foggy

**Traffic Control**

The posted speed for the road in the area of this collision is 40 km/h. The speed limit is clearly posted for both sides with Type R 40 KM/H speed limit signs. The speed limit was established by a traffic engineering and speed survey.

MALT PREPARER'S NAME	I.D. NUMBER	DATE	REVIEWER'S NAME	DATE
A. Ahubudu	1120	6/20/06		

## SRI LANKA POLICE DEPARTMENT MAJOR ACCIDENT INVESTIGATION TEAM

DATE OF INCIDENT	TIME	NCIC NUMBER	OFFICER I.D.	NUMBER
June 20, 2006	0518	3710	1120	06-017742

**VEHICLES****Vehicle One (1999 Nissan Super Saloon)****Description**

Year: 1999  
 Make: Nissan  
 Model: Super Saloon  
 License: [REDACTED]  
 VIN: [REDACTED]  
 Engine: 2200cc V4  
 Transmission: 5 speed Manual  
 Color: Red  
 Type: 4 door  
 Weight: 1225 kg

**Damage Description:****Front:**

There was moderate to severe damage to this portion of V 1. There was crumpling and creasing to the hood and sub-frame, along with breaks to the plastic front grill. Both headlights were broken out. An examination of the broken bulbs showed oxidation and melting to the filament. This indicated that the headlights were in the "On" position at the time of this collision. Some of the engine fluids (oil, coolant, brake fluid, etc.) had spilled onto the roadway at the collision scene.

**Right**

V1 sustained no visible damage to this end.

**Left**

V1 sustained no visible damage to this end.

**Rear**

V1 sustained no visible damage to this end.

**Roof**

V1 sustained no visible damage to this end.

MALT PREPARER'S NAME	I.D. NUMBER	DATE	REVIEWER'S NAME	DATE
A. Ahubudu	1120	6/20/06		

## SRI LANKA POLICE DEPARTMENT MAJOR ACCIDENT INVESTIGATION TEAM

DATE OF INCIDENT	TIME	NCIC NUMBER	OFFICER I.D.	NUMBER
June 20, 2006	0518	3710	1120	06-017742

**VEHICLES (Continued)**Vehicle Two (1994 Ford Fiesta)**Description**

Year: 1994  
 Make: Ford  
 Model: Fiesta  
 License: [REDACTED]  
 VIN: [REDACTED]  
 Engine: 1300cc V4  
 Transmission: 4 speed Manual  
 Color: Black  
 Type: 2 door  
 Weight: 1238 kg

**Damage Description:**Front:

V2 sustained major damage to the entire front side from of the impact with V1. The center of the grill/bumper area was completely crushed and destroyed. No evidence of oxidation or melting of the headlight filaments could be found. This indicates that the headlights of V2 were in the "Off" position at the time of impact.

Right

V1 sustained no visible damage to this end.

Left

V1 sustained no visible damage to this end.

Rear

V1 sustained no visible damage to this end.

Roof

V1 sustained no visible damage to this end.

MALT PREPARER'S NAME	I.D. NUMBER	DATE	REVIEWER'S NAME	DATE
A. Ahubudu	1120	6/20/06		

## SRI LANKA POLICE DEPARTMENT MAJOR ACCIDENT INVESTIGATION TEAM

II

DATE OF INCIDENT	TIME	NCIC NUMBER	OFFICER I.D.	NUMBER
June 24, 2006	0445	3710	1120	06-014874

**INTRODUCTION**

This traffic collision occurred on Saturday June 24, 2006, at approximately 0445 hours. This collision occurred within the intersection of Route A4 and Benet Rd, within the incorporated City of Colombo.

This collision involved a 2006 Acura TSX (V1) and a 2004 Ford Sterling Cement Truck (V2). The Acura was driven by [REDACTED], henceforth referred to as Person 1. The Ford was driven by [REDACTED], henceforth referred to as Person 2. The passenger in the Acura, seated in the front right seat, was [REDACTED].

The Acura was traveling eastbound on Route A4, in the number two lane of travel. The Ford had just entered the intersection, from the left turn lane, northbound Benet Rd to westbound Route A4. At impact, the Ford was in second gear. Maximum speed for a vehicle of this size, in second gear is 7-10 mph. This data can be supported by several case studies from the American National Highway Traffic Safety Administration and other related studies involving vehicles of this size.

The force of the impact between the Acura and the Ford, forced the Ford to be moved from an angle of a left turn to positioning straight forward. The Acura was moved from traveling eastbound to facing southbound. All parties involved in this collision received injuries and were either treated on scene or transported to local hospitals. The passenger in the Acura died from his injuries at 2000 hours on June 24, 2006.

**PHYSICAL EVIDENCE**

I documented the scene, walking from east to west. On the south side of Route A4 in the number two lane of eastbound traffic, I noticed skid from V1. This skid was measured by a roll meter with a distance of 67 feet. An additional 20 feet of skid was within the intersection, caused by the two vehicles sliding together. This evidence leads me to believe that P1 noticed V2 turning in the intersection and applied his brakes in a "Panic" situation.

At the collision scene, there was evidence of V1 and V2's impact within the intersection. V1 was still impacted with the front left tire of V2. There was a mixture of engine fluids, vehicle parts, and glass. Using marking paint, I painted both V1 and V2 in their original positions before they were moved by tow trucks.

An interior inspection of V2 showed that it was "locked" in second gear and even when depressing the clutch, I could not remove the vehicle out of second gear. The tow driver had to manually unlock the transmission to move V2.

MAIT PREPARER'S NAME	I.D. NUMBER	DATE	REVIEWER'S NAME	DATE
A. Ahubudu	1120	6/24/06		



## SRI LANKA POLICE DEPARTMENT MAJOR ACCIDENT INVESTIGATION TEAM

II

DATE OF INCIDENT	TIME	NCIC NUMBER	OFFICER I.D.	NUMBER
June 24, 2006	0445	3710	1120	06-014874

**SCENE:**

Section Omitted

**Weather Conditions**

The following weather conditions were noted at the Colombo Airport. The airport is about 1/4 mile north of the collision scene.

Time	Temperature	Dew Point	Humidity	Pressure	Visibility	Wind	Conditions
4:52 AM	64.9° F/18.3° C	61.0° F/16.1° C	87%	29.95 in/ 1014.1 hPa	4.0 miles/ 6.4 km	3.5 mph/ 5.6 km/h WWS	Overcast
5:52 AM	64.9° F/18.3° C	61.0° F/16.1° C	87%	30.00 in/ 1015.8 hPa	4.0 miles/ 6.4 km	8.1 mph/ 13.0 km/h SSE	Overcast
6:44 AM	66.2° F/19.0° C	62.6° F/17.0° C	88%	30.01 in/ 1016.1 hPa	3.0 miles/ 4.8 km	3.5 mph/ 5.6 km/h North	Overcast

**Traffic Control**

The intersection of Route A4 and Benet Rd is controlled by a four way electrical signal system. During this investigation, I observed the signal phase from all four directions and found them to be working properly. The posted speed limit for Route A4 is 55 mph. The speed limit is clearly posted for both east and westbound traffic with Type R 55 MPH speed limit signs. The speed limit was established by a traffic and engineering survey.

**VEHICLES**

Vehicle One (V1, 2006 Acura TSX)

**Description**

Year: 2006  
 Make: Acura  
 Model: TSX  
 License: [REDACTED]  
 VIN: [REDACTED]  
 Engine: 2.4 L 205 hp 14  
 Transmission: 5 speed Automatic  
 Color: Blue  
 Type: 2 Door  
 Weight: 3256.2 pounds

MAIT PREPARER'S NAME	I.D. NUMBER	DATE	REVIEWER'S NAME	DATE
A. Ahubudu	1120	6/24/06		

## SRI LANKA POLICE DEPARTMENT MAJOR ACCIDENT INVESTIGATION TEAM

5/30

DATE OF INCIDENT	TIME	NCIC NUMBER	OFFICER I.D.	NUMBER
June 24, 2006	0445	3710	1120	06-014874

**VEHICLES (Continued)****Damage:****Front:**

The damage sustained to this portion of V 1 consisted of the entire front bumper being removed from the vehicle. The right side headlight assembly was completely broken out. An inspection of the broken headlight assembly, with the exposed headlight bulb filament, showed signs of oxidation and melting of the filament. This evidence showed that P1 had the headlights of V1 in the "On" position. The hood and right quarter panel was crumpled and dented. V1 had also expelled some of its engine fluids, i.e. Radiator fluid, oil, brake fluid.

**Right:**

The only damage sustained on this side of V 1 was the front right quarter panel. This damage consisted of the quarter panel being dented and crushed.

**Left:**

Besides slight crumpling and warping to the front left quarter panel, no other damage was sustained to this side of V1.

**Rear:**

I did not observe any damage to this portion of V1.

**Roof:**

I did not observe any damage to this portion of V1.

MAIT PREPARER'S NAME	I.D. NUMBER	DATE	REVIEWER'S NAME	DATE
A. Ahubudu	1120	6/24/06		

SRI LANKA POLICE DEPARTMENT MAJOR ACCIDENT INVESTIGATION TEAM

DATE OF INCIDENT	TIME	NCIC NUMBER	OFFICER I.D.	NUMBER
June 24, 2006	0445	3710	1120	06-014874

**VEHICLES (Continued)**

Vehicle 2 (V2, 2004 Ford Sterling)

**Description:**

Year: 2004  
 Make: Ford  
 Model: Sterling  
 License: [REDACTED]  
 VIN: [REDACTED]  
 Engine: Mercedes MBE 4000 450  
 Transmission: 8LL  
 Color: White  
 Vehicle Type: 3 Axle Short Pour Cement Mixer  
 Weight: 18600 pounds

**Damage:**

Front:

No visible damage had occurred to this side.

Left:

Besides the front left wheel assembly being broken, with several air and fluid lines broken, no other visible damage occurred to this side.

Right:

No visible damage had occurred to this side.

Rear:

No visible damage had occurred to this side.

MAIT PREPARER'S NAME	I.D. NUMBER	DATE	REVIEWER'S NAME	DATE
A. Ahubudu	1120	6/24/06		

## SRI LANKA POLICE DEPARTMENT MAJOR ACCIDENT INVESTIGATION TEAM

II

DATE OF INCIDENT	TIME	NCIC NUMBER	OFFICER I.D.	NUMBER
Jan 11, 2006	1057	3710	1120	07-000863

**INTRODUCTION**

On Thursday, January 11, 2007 at approximately 1057 hours, a traffic collision occurred within the intersection of Tikali Dr. and Vihara Rd. A 1995 Volkswagen Jetta, which was traveling westbound on Tikali Dr, struck a 1992 Saturn SL-1 broadside, which was traveling southbound on Vihara Road.

The 1992 Saturn SL-1 (V1) was driven by [REDACTED], henceforth referred to as Person 1, who sustained major injuries in this collision and was transported, via ambulance, to Colombo Trauma Center. P1 died at 2030 hours, due to his injuries.

The 1995 Volkswagen Jetta (V2) was driven by [REDACTED], henceforth referred to as Person 2, who sustained minor injuries in this collision and was transported, via ambulance, to Kelaniya Medical Center for treatment. P2 was later released from the hospital.

Based on the statement of P2 and three independent witnesses, P1 had run the red light for southbound Vihara Rd. P2 had a green light for westbound Tikali Dr. Evidence at the scene showed that P1 may have been aware that P2's vehicle was about to impact with him. There were front wheel locked skid marks, just prior to the collision. The force of the collision caused the two vehicles to skid together to rest.

**PHYSICAL EVIDENCE**

At the Area of Impact, I observed locked wheel skid from the front tires of V1 prior to the area of impact. This wheel skid was measured to be 10 feet. The skid marks post-collision measured to be 35 feet in the southwest direction [220° Azimuth].

**Roadway Description**

Section Omitted

MAIT PREPARER'S NAME	I.D. NUMBER	DATE	REVIEWER'S NAME	DATE
A. Ahubudu	1120	1/11/07		

## SRI LANKA POLICE DEPARTMENT MAJOR ACCIDENT INVESTIGATION TEAM

II

DATE OF INCIDENT	TIME	NCIC NUMBER	OFFICER I.D.	NUMBER
Jan 11, 2006	1057	3710	1120	07-000863

**Weather Conditions**

The following weather conditions were noted at the Colombo Airport.

Time	Temperature	Dew Point	Humidity	Pressure	Visibility	Wind	Conditions
10:29 AM	60.8° F/16.0° C	48.2° F/9.0° C	63%	29.96 in/ 1014.4 hPa	9.0 miles/ 14.5 km	8.1 mph/ 13.0 km/h South	Overcast
10:52 AM	61.0° F/16.1° C	48.0° F/8.9° C	62%	29.96 in/ 1014.4 hPa	9.0 miles/ 14.5 km	9.2 mph/ 14.8 km/h South	Overcast
11:42 AM	60.8° F/16.0° C	46.4° F/8.0° C	59%	29.93 in/ 1013.4 hPa	10.0 miles/ 16.1 km	9.2 mph/ 14.8 km/h South	Overcast

**VEHICLES****Vehicle One (VI, 1992 Saturn SL-1)**

Year: 1992  
 Make: Saturn  
 Model: SL-1  
 Color: Brown  
 License: [REDACTED]  
 VIN: [REDACTED]  
 Engine: 1.9L 85 hp 14  
 Transmission: 4 speed automatic  
 Weight: 2313 pounds

**Damage Description:****Front:**

V1 sustained no visible damage to this end.

**Left:**

The majority of the damage sustained by V1 occurred on this side. At the deepest intrusion, the crush measured 36". The entire left side from the driver's side door to the passenger side door was crushed. There was minor to moderate crushing to the front and rear quarter panels.

**Right:**

Besides the removing of the passenger front and rear doors by SLFD with the Jaws of Life, no visible collision damage was observed on this side.

**VEHICLES (Continued)**

MAIT PREPARER'S NAME	I.D. NUMBER	DATE	REVIEWER'S NAME	DATE
A. Ahubudu	1120	1/11/07		

## SRI LANKA POLICE DEPARTMENT MAJOR ACCIDENT INVESTIGATION TEAM

12/26

DATE OF INCIDENT	TIME	NCIC NUMBER	OFFICER I.D.	NUMBER
Jan 11, 2006	1057	3710	1120	07-000883

**Damage (Continued)****Rear:**

V1 sustained no visible damage to this end.

**Vehicle Two (V2, 1995 Volkswagen Jetta III Celebration Edition)**

Year: 1995  
 Make: Volkswagen  
 Model: Jetta III Celebration Edition  
 Color: Black  
 License: [REDACTED]  
 VIN: [REDACTED]  
 Engine: 2.0 L 115 hp I4  
 Transmission: 5 Speed manual  
 Weight: 2648 pounds

**Damage Description:****Front:**

The majority of the damage sustained by V2 was isolated to this side. There was moderate crushing to the front bumper and hood. The length of crush to the front end was 6" at its deepest point. The both headlight and lighting assemblies were broken and knocked out.

**Left:**

Besides minor crush and dents to the front portion of the front quarter panel, no other visible damage was observed to this side.

**Right:**

Besides minor crush and dents to the front portion of the front quarter panel, no other visible damage was observed to this side.

**Rear:**

V2 sustained no visible damage to this end.

MAIT PREPARER'S NAME	I.D. NUMBER	DATE	REVIEWER'S NAME	DATE
A. Ahubudu	1120	1/11/07		

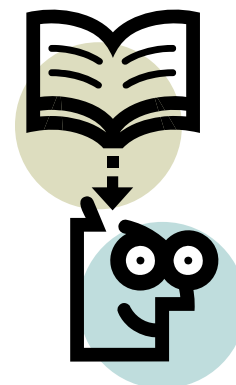
## Appendix B: Multimedia Example MEA

### MEMORANDUM

---

**To:** Dynamics R Us Educational Consultants  
**From:** Smith Publishing Inc.  
**Date:** 10.27.08  
**Subject:** Multimedia Based Student Learning Tools

---



We are pleased to announce the completion of our new website for college level engineering students. In order to expand our current educational product offerings beyond textbooks, we are currently offering additional educational information on the web. Our website is intended to provide additional aid outside of the classroom to help students understand fundamental engineering concepts.

Currently, our website offers a wide selection of example problems to supplement statics, dynamics, thermodynamics and heat transfer textbooks. We are pleased with the responses that we have been receiving regarding this new site, but we want to do more. Here at Smith Publishing we have a passion for education and understand that all students have different learning styles. To expand our audience and to help more students in their quest for knowledge we will be dedicating a portion of our site to multimedia learning.

We plan to hire university professors who have taught with our textbooks to create some of these multimedia tools. In order to provide consistency to their submissions, we need to provide guidelines to them. Due to your extensive experience in student education, we would like you to create these guidelines for us.

It would be extremely helpful if you could outline what you think are the most important characteristics to make a good multimedia example problem. Please follow this with specific guidelines that we can provide to the professors who will create the examples for us. We would also like you to create one example problem that we can send to potential contributors.

Thank you for your time and we look forward viewing your guidelines and multimedia example problems.

*John B. Noble*

John B. Noble  
Chief Executive Officer  
Smith Publishing Inc.

## Appendix C: Catapult MEA



### MEMORANDUM

---

**To:**

**From:** Peterborough City Council for Peterborough Museum Art Gallery

**Date:** 11.17.08

**Subject:** Catapult design for upcoming Medieval Machines Exhibition

---

Due to the overwhelming success of our most recent interactive Medieval Machines exhibition, we are pleased to announce plans for a similar exhibition this upcoming year. We will use many of our existing medieval displays and activities but are also looking to expand the exhibition this time around and will need the help of your engineering design firm in developing our newest featured display.

This year, the featured display will be a full size medieval catapult replica which will be used in a series of demonstrations. In order to develop successful demonstrations for the catapult display, we need you to provide us with a selection of different launch settings. A launch setting is defined by launch angle, pin location and catapult base height. The settings you provide us with will allow the users to hit specifically placed targets. Along with the specific launch settings, we also need some sort of algorithm or instruction set from your engineers which explains how to find a launch setting for a given distance between the catapult and target. With your instruction our employees using the catapult should be able to make any necessary changes if any issues or complications may arise on launch day.

To aid your progress we will be providing you with a scale model of the catapult here at our museum in Peterborough, England. All dimensions and material stiffness are accurately scaled which should provide you with all of the necessary information and will allow you to test your findings and prove your results. Accuracy in this demonstration is critical for both the safety of our museum guests and employees as well as for a successful demonstration.

For further information on our museum and our medieval programs please view our past articles at the links below. Thank you for your time and we look forward reviewing your results.

John Smith

Peterborough Museum Art Gallery Program Director



# **Development of a Student-Centered Hands-on Laboratory Experiment of Chemical Detection using Micro-cantilever Sensor and Optical Lever Amplification Technique \***

**Geon S. Seo**

*Department of Aerospace and Mechanical Engineering  
University of Arizona*

**Eniko T. Enikov**

*Department of Aerospace and Mechanical Engineering  
University of Arizona*

## **ABSTRACT**

The development of an undergraduate experiment in micro- and nanotechnology based on the detection of chemicals via microcantilever sensors is described. The modified process allows the use of a simple wet-etching station to produce the cantilevers using commercially available substrates, which allows schools without access to clean room facilities to implement the experiment. Simple data analyses demonstrating first-order adsorption kinetics and Langmuir isotherm have also been included to assist in the interpretation of the data. Assessment of the educational impact of the experiment has shown a significant increase in domain knowledge and total engineering design experience of the students. Comparison between groups that have participated in design-only version vs. full-scale hands-on experimentation show increased appreciation of the field of nanotechnology, as well as in the students' perceptions of their marketability.

\* An expanded version of this manuscript has been submitted for publication in International Journal of Engineering Education.

## INTRODUCTION

The field of engineering involves the application of known scientific principles to harvest the three basic resources of human kind—energy, materials, and information—in order to create useful tools and technologies. Consequently, engineering education has the objective of not only presenting the scientific principles, i.e., engineering science, but also of teaching students how to apply these to real problems. It is not surprising, therefore, that hands-on laboratories have been an integral part of the engineering curriculum since its inception [1]. Their importance has been recognized by the Accreditation Board of Engineering Education (ABET) and its predecessors by creation of criteria requiring adequate laboratory practice for students [2-6]. Unfortunately, during the last several decades, engineering laboratories have become highly complex and expensive, with multiple simulation tools and computer-controlled test and measurement equipment [7-8]. Moreover, ironically enough, the high cost of fabrication and testing of MEMS/NEMS devices often leads to very superficial, demonstration-style laboratory courses, even though this new engineering field can be a unique opportunity to foster important skills by exposing students to disciplines outside of their major. As a result, the students are mere observers in these high-tech laboratories.

One possible solution to the critical need for laboratory experience is to develop a student-centered learning environment based on the use of inexpensive portable micro-experiments. This paper reports on our experience in developing such a low-cost, hands-on exercise in the design and use of microcantilever sensors for chemical detection. While the first demonstrations were primarily focused on the detection of vapors alkanethiols [9], more recent applications have included detection of heavy metal ions (Hg, Cu, As) in liquids [10] and organic molecules [11]. The later are particularly well-suited for classroom exercises, as many issues associated with safe handling of organic vapors have been eliminated. Cantilever beams and their deformation under mechanical loads is a classical undergraduate topic covered in all mechanical engineering programs. The most common method of measuring the deflection of a cantilever is the optical lever technique as shown in Fig 1. The technique works with a focused laser diode beam at the free end of the cantilever, which is reflected onto a position-sensitive detector (PSD). When the cantilever bends due to adsorption-induced surface stress, the reflected light moves on the photo-detector surface, and this movement is proportional to the cantilever deflection. The Stoney formula, which relates the bending of cantilevers to the surface stress given by Eq. (1), is now widely used in surface stress measurements and in the design of cantilever sensors,

$$R = \frac{Et^2}{6\Delta\sigma(1-\nu)}, \quad (1)$$

where  $E$  is elasticity of the cantilever,  $t$  is the thickness of cantilever,  $\nu$  is the Poisson ratio, and  $\Delta\sigma$  is difference in the surface stresses between the top and the bottom sides of the cantilever.

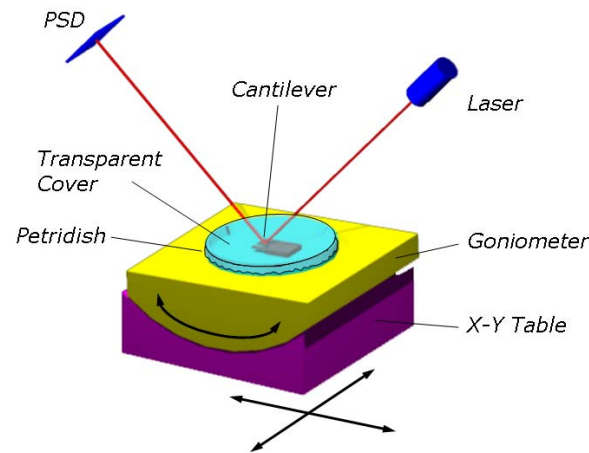


Fig 1. Schematic of cantilever sensor using the optical lever technique.

As illustrated in Fig 2(a), assuming constant curvature, the deflection angle  $\Delta\theta$  at a distance  $L$  from the base of the cantilever is given by

$$\Delta\theta = \frac{L}{R}. \quad (2)$$

The deflection angle is then amplified using the “optical lever” technique, as shown in Fig 2(b), i.e. by monitoring the position of the reflected laser beam illuminating a position sensitive detector at a distance  $d$  from the cantilever

$$\Delta x = 2d\Delta\theta = \frac{12dL\Delta\sigma(1-\nu)}{Et^2}. \quad (3)$$

Therefore, by monitoring the deflection of the reflected beam, one can determine the surface stress, provided that the elastic and geometric constants of the cantilever are known. This simple geometry and the principle of operation of cantilever sensors make them a good educational tool in nanotechnology. Although many groups reported experiments using cantilever micro sensors, the actual procedures are complicated and some steps demand special and complex equipment, not commonly available at most educational institutions. In this paper, we describe our effort to develop a hands-on laboratory experiment with reduced complexity utilizing inexpensive fabrication process.

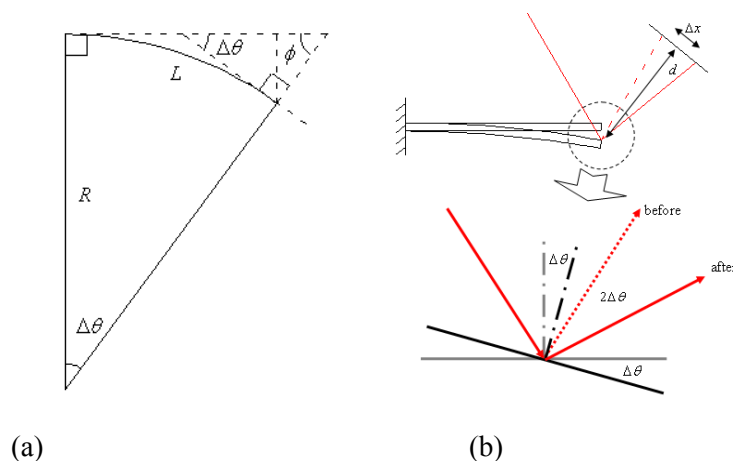


Fig 2. Geometry of beam bending (a), and Schematic of the “optical lever” technique (b).

## EXPERIMENTAL SECTION

### *Preparation of Cantilevers and Chemicals*

The microcantilevers used in this work were fabricated by a traditional microfabrication process with dimensions of 300  $\mu\text{m}$  length, 100  $\mu\text{m}$  width, and 560 nm thickness, with a 50 nm thick Au layer. The fabrication process and resulting array of cantilevers are shown in Fig 3. The films are patterned by photolithography and the cantilever itself is formed by wet etching with CsOH. The large lateral etch rate of convex corners results in undercutting and produces freestanding cantilevers. Surface modification with thiolated ligand is performed by immersion of the microcantilever into a 10 mL solution of 1 mM cysteine in ethanol for 2 hours [10]. Upon removal from the ligand solution, microcantilevers are rinsed with ethanol and DI water, and then stored at room temperature in 1 M acetate buffer (AB) with pH 5.

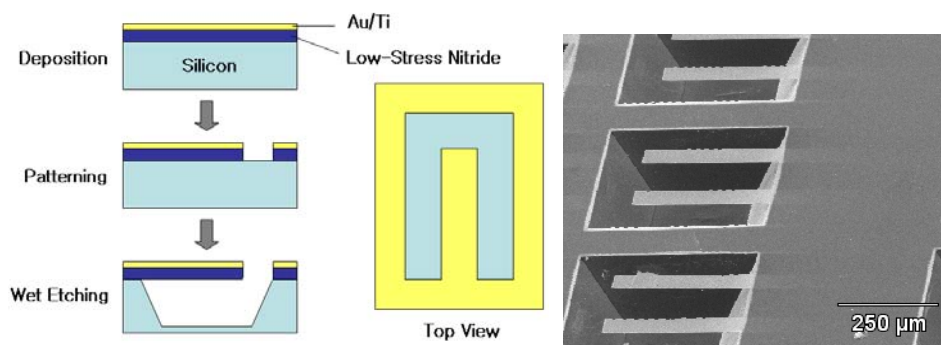


Fig 3. Fabrication process and microcantilevers.

Copper chloride solutions were prepared in pH 5 AB (1 M), which was also used as a carrier solution. An example test protocol consists of a 0.5 mL solution of 2.5 mM copper chloride

added into 24.5 mL of AB to make a 25 mL solution of 0.05 mM copper chloride, and a 1 mL solution of 2.5 mM copper chloride added into 24 mL of AB, for 0.1 mM.

### Hardware

The optical measurement system has three components: laser source, positioning stage, and a detector, and all subsystems are installed on a portable optical bench as shown in Fig 4. The system was connected to a PC through an RS232 interface; the PC drives the system and collects the experimental data using MatLab. The PSD was integrated into a PCB (PCB1) with a micro-controller (PIC 16F684) and an OP-Amp (AD8554), and another PCB (PCB2) consisting of a dual driver/receiver (Max232) and a micropower regulator (LT1763), as shown in Fig 5. The schematics of the electric circuit, the layout of the PCBs, the associated assembly code and MatLab codes can be found on our laboratory web site [12].

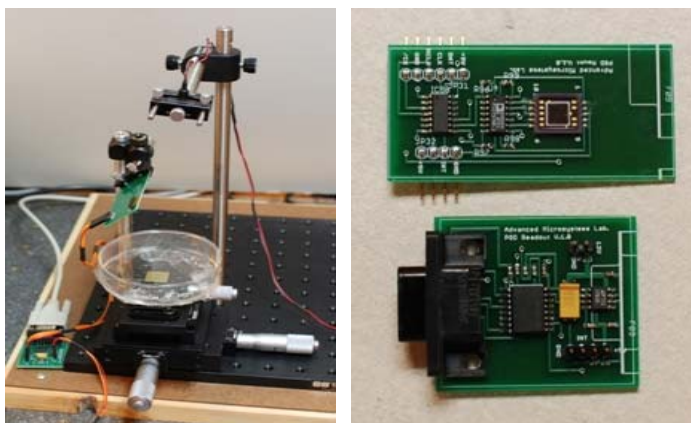


Fig 4. Experimental setup and photodetector PCB.

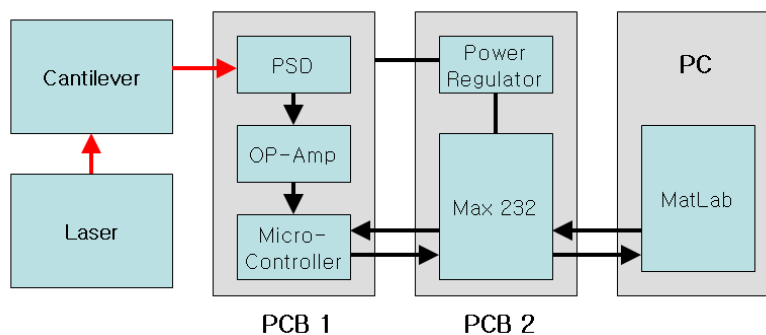


Fig 5. Block diagram of system.

### Deflection Measurements

The modified cantilever was mounted inside a Petri dish and soaked in pH 5 AB. The Petri dish was wrapped in a transparent plastic cover that has a small hole through which the copper solution is injected, and it was then placed on the stage. The next steps are to focus a laser beam

onto the smallest spot size and to set PSD position and angle. Prior to a detection experiment, the distance between the cantilever and the PSD has to be calculated to allow determination of the curvature or surface stress. The displacement of the reflected beam on the PSD was measured by inducing a known change of angle using the goniometer. The distance between the cantilever and the PSD,  $d$ , can then be calculated from Eq. (3). Using a low-power microscope, the laser beam was positioned at the end of one of the cantilevers via the X and Y translation stages. Finally, a copper chloride solution was added to AB in the Petri dish using a pipette, and the resultant deflection was stored in the PC.

### ANALYSIS OF EXPERIMENT RESULTS

Figure 7 shows the displacement of the reflected beam on the PSD as a function of time of exposure to copper chloride solutions of three different concentrations. Since the surface stress is proportional to the number of adsorbed molecules [13] and the displacement of the reflected beam on the PSD is also proportional to the surface stress, we have fitted the experimental adsorption curves with the Langmuir adsorption model as follows:

$$\dot{\theta} = k_a c N (1 - \theta) - k_d N \theta = A(1 - \theta) - B\theta. \quad (4)$$

The first-order isotherm solution described as

$$\theta = \frac{A}{A + B} \left( 1 - e^{-t(A+B)} \right), \quad (5)$$

where  $\theta$  is the fraction of occupied sites,  $k_a$  and  $k_d$  are adsorption and desorption reaction rate constants respectively,  $c$  is the concentration of solution,  $N$  is the total number of sites on the surface,  $A$  is  $k_a c N$ , and  $B$  is  $k_d N$ . Table 1 shows the constants  $A$  and  $B$  as a result of the first-order Langmuir adsorption isotherm fitting. According to this result, the time constant and the steady-state value are proportional to the molar concentration of copper ions, and the adsorption and desorption reaction rate constants are also a function of the molar concentration.

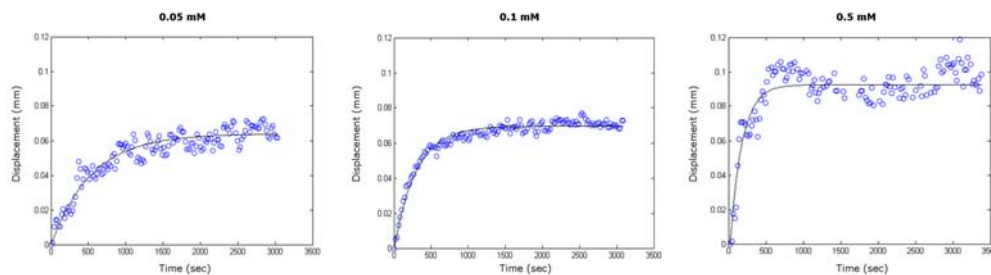


Fig 7. Displacement of reflected beam on PSD (0.05, 0.1, and 0.5 mM).

Table 1. The result of the first-order Langmuir adsorption isotherm fitting.

Concentration	$A = k_a c N$	$B = k_d N$
0.05 mM	0.0001	0.0017
0.1 mM	0.0002	0.0031
0.5 mM	0.0006	0.0057

### PROCESS OF MODIFICATIONS ENABLING USE IN THE CLASSROOM

In a typical fabrication process, the Au layer is deposited after the cantilevers have been etched and released. The rationale behind this is to prevent contamination during etching. However, in a classroom setting, it is convenient to have a stock of pre-deposited wafers so that students can quickly etch their cantilevers. Therefore, we have reversed the order of etching and Au deposition and tested the effect of surface contaminants during etching.

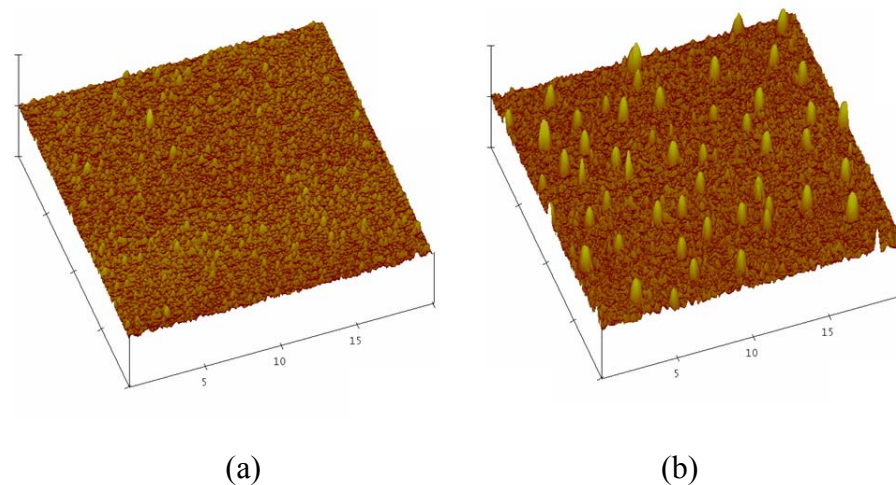


Fig 8. Three-dimensional images of the gold surface before (a) and after (b) wet etching.

Figure 8 shows AFM scans of the Au surface before and after etching. The r.m.s. roughness value was increased from 3.4 nm to 8.5 nm (about 2.47 times), and the area covered by surface contaminants was approximately 9.8 %. Since the length of cystein is only a few angstroms [14], regions with contamination are most likely completely inactive. Although the roughness of the gold surface increased during the silicon wet etching process, it allows institutions that do not have a cleanroom facility to perform this experiment by purchasing pre-deposited silicon wafers.

### ASSESSMENT OF EDUCATIONAL MERIT

In order to evaluate the educational impact of this hands-on laboratory experiment, we compared feedback surveys from two groups of students attending “ABE/AME 489 Engineering

Properties and Micro/Nano Technologies for Biological Systems” in Fall semesters 2005 and 2007 at the University of Arizona. In both semesters, students learned the same topics and performed the same design term project based on a microcantilever sensor. However, in 2005 they designed cantilever sensors and simulated their deflection using computer programs such as ANSYS, SolidWork, and MatLab, and in 2007 the students fabricated their own cantilever sensors and performed the experiment on deflection measurements with them.

Table 2. The results of surveys.

Questions (Answer: 1 - 10)	Fall 2005			Fall 2007		
	Aug. 26	Dec. 9	Diff.	Aug. 2	Nov. 29	Diff.
1. How much do you know about nanotechnology?	3.78	7.33	3.55	3.00	7.00	4.00
2. How much do you know about biosensors?	3.33	7.43	4.10	4.50	8.17	3.67
3. How much do you know about semiconductor processing?	4.44	6.14	1.70	2.00	6.17	4.17
4. Are you considering further studies in nanotechnology?	8.67	8.14	-0.53	5.83	6.00	0.17
5. Do you think nanotechnology provides valuable educational experience?	9.33	8.86	-0.47	8.67	9.33	0.67
6. Are you likely to recommend this class to your peers?	8.67	7.43	-1.24	5.83	7.00	1.17
7. Do you think this course will help you find a better job/grad school?	8.33	7.57	-0.76	5.67	7.50	1.83

We asked the same questions at the beginning and at the end of the class to assess the effect of the course. As shown in Table 2, students acquired a lot of knowledge about nanotechnology and biosensors and increased their total design experience through the lectures and the design portion the course. Also, they obtained knowledge about semiconductor processing during both semesters, but the increment in 2007 was much larger than that in the previous year. Furthermore, the interest in nanotechnology showed a small decrease as students’ preferences shifted from a lecture and lab/design course to a lecture-only one. The lecture/simulation-based course seems to have fallen short of the expectations of students in 2005. On the other hand, students in 2007 showed more interest in nanotechnology and their feedback was positive in general. This survey result shows that a hands-on laboratory experiment is a more effective educational approach than a simple computer



simulation, and it seems to provide more valuable experience and practical knowledge to students.

### CONCLUSIONS

The modified experimental setup and method described here offer a simpler and more convenient hands-on laboratory experiment in nanotechnology. The reversal of gold deposition allows schools without access to clean room facilities to implement the experiment using commercially available substrates. The experimental data allow illustration of micro-technology, as well as classical theorems such as the Langmuir adsorption isotherm. The hands-on laboratory experiments have been shown to contribute to the total design experience of our students, which is required by ABET, and assessment of the educational impact of the experiment has shown a significant increase in domain knowledge and total engineering design experience of the students.

### ACKNOWLEDGMENT

The authors acknowledge the financial support of the National Science Foundation under Grant Nos. 0633312 and 0637052.

### REFERENCES

1. L.D. Feisel and A.J. Rosa, The Role of the Laboratory in Undergraduate Engineering Education. *Journal of Engineering Education*, 94, 121–130 (2005)
2. Report of the Commission on Engineering Education. *Journal of Engineering Education*, 58, 191–195 (1967)
3. Final Report of the Quality of Engineering Education Project (QEEP). Washington, D.C.: American Society for Engineering Education, 125–145 (1986)
4. A National Action Agenda for Engineering Education. Washington, D.C.: American Society for Engineering Education (1987)
5. E.W. Ernst, Editor, The Undergraduate Engineering Laboratory. Proceedings of an Engineering Foundation Conference, July 24–29 (1983)
6. Engineering Criteria 2000, Baltimore, MD: ABET (2002)
7. M.F. Aburdene and M. El-Sharkawy, Integrated Engineering Workstations in Electrical Engineering Laboratories. *IEEE Transactions on Education*, E-32, 404–408 (August 1989)
8. J. Kadlowec, P. von Lockette, E. Constans, B. Sukumaran and D. Cleary, Visual Beams: Tools for Statics and Solid Mechanics. Proceedings, 32nd ASEE/IEEE Frontiers in Education Conference, Boston Mass., November 6–9, 1, T4D7-T4D10 (2002)

9. R. Berger, E. Delamarche, H.P. Lang, C. Gerber, J.K. Gimzewski, E. Meyer and H-J. Guntherodt, Surface Stress in the Self-assembly of Alkanethiols on Gold Probed by a Force Microscopy Technique. *Applied Physics A*, 66, S55–S59 (1998)
10. P. Dutta, P.J. Chapman, P.G. Datskos and M.J. Sepaniak, Characterization of Ligand-Functionalized Microcantilevers for Metal Ion Sensing. *Analytical Chemistry*, 77, 6601–6608 (2005)
11. G.M. Whitesides, E. Ostuni, S. Takayama, X. Jiang and D.E. Ingber, Soft Lithography in Biology and Biochemistry. *Annual Reviews in Biomedical Engineering*, 3, 335–373 (2001)
12. <http://www.nano.arizona.edu/>
13. R. Desikana, I. Lee and T. Thundat, Effect of Nanometer Surface Morphology on Surface Stress and Adsorption Kinetics of Alkanethiol Self-assembled Monolayers. *Ultramicroscopy*, 106, 795–799 (2006)
14. Y.J. Lee and I.-H. Suh, The Crystal and Molecular Structure of N-Acetyl-L-cysteine. *Journal of the Korean Chemical Society*, 24, 193–200 (1980)

### **Biographical Information**

**Geon S. Seo** received his MS degree from Korea Advanced Institute of Science and Technology (KAIST) in 1996 and PhD degree from the University of Arizona in 2004. During his graduate studies in the Advanced Micro and Nanosystems Laboratory, he analyzed the mechanism of actuation and developed mathematical transport and deformation model of ion-exchange polymer/metal composite (IPMC) actuators. Currently, Dr. Seo is a Research Associate in the Department of Aerospace and Mechanical Engineering at the University of Arizona, and his research is focused on the design, fabrication and modeling of micro-electromechanical systems (MEMS) sensors, and the integration of MEMS sensors with biomedical applications.

**Eniko T. Enikov** is an Associate Professor of Aerospace and Mechanical Engineering at the University of Arizona. He received his PhD degree from the University of Illinois at Chicago in 1998. Since then he has worked as a post-doctoral associate at the University of Minnesota and subsequently as an Assistant and Associate Professor at the University of Arizona. There, he established the Advanced Micro and Nanosystems Laboratory with sponsorship from multiple federal agencies (AFOSR, NSF, DOE, DE) and the private sector. Prof Enikov has also led numerous educational programs including summer school in micro-systems design held in Udine, Italy, 2004, student exchange programs with ETH, Zurich, Budapest University of Technology and Economics, and Slovak Technical University of Bratislava. Prof Enikov is a recipient of several prestigious awards including NSF Career award (2001), US Dept. of State Fulbright Research Scholarship in Hungary (2007).

## **Modeling the Dynamics of a Small Catapult to Enhance Undergraduate Studies**

Lawrence Fong and Brian Self  
California Polytechnic State University, San Luis Obispo

### **Abstract**

It is estimated that the average engineering student will work 3000 "back of the book" style homework problems by the time that they graduate. While these problems can certainly help with the learning process, many do not mimic any type of real world systems that an engineer will encounter in their careers. Furthermore, most do not require the student to develop a physical model of the actual system that they attempt to analyze - this is already done for them in the problem. An example of this can be found in any dynamics book; the work-energy chapter invariably contains problems with springs attached to different slender rods in a variety of different contrived orientations.

We have attempted to improve student analytical skills and to provide real world context to the study of rigid body dynamics by creating a catapult project. Students are given rubber bands, catapults, rulers, weights, and a scale. They must determine how to model the arm, the energy stored in the rubber bands (e.g., linear or non-linear springs), and the ensuing projectile motion. Their computations are then tested on launch day - when raw eggs are hurled 20 to 45 feet at a small picture of their instructor.

There are a number of different dynamics aspects that can be incorporated into the catapult project. The fixed pin that holds the arm at the bottom can be analyzed using Newton's second law, and a stopper pin that the arm hits can be examined using impulse momentum principles. Students have even analyzed the internal axial stress at a point in the arm as a function of the arm angle as the arm rotates.

The catapult project is easy to implement and provides a real world artifact that students must analyze. They make decisions about how to model a true physical system, what effects are negligible (e.g, drag and friction), and what measurements must be taken. We have found this to be a motivational and fun way to help students learn about rigid body dynamics.

## Introduction

At Cal Poly, students have always been encouraged to utilize a hands-on approach towards learning. In our coursework, we have found that real-world type of problems help students learn the material more effectively, as well as prepare them for careers in engineering. Throughout all the laboratories and student projects, Cal Poly's "learn by doing" motto is evident - in how we apply the principles of engineering towards realistic situations, instead of simply towards a boxed answer.

The catapult project is a MEA (Model Eliciting Activity) that is presented to students in Cal Poly's Mechanical Engineering department. These activities aim to promote a more practical and applicable form of learning for students by incorporating real-world situations and open-ended solutions. This particular MEA has been successfully used in two Engineering Dynamics classes (in Cal Poly's Curriculum: ME212). It has also been presented as a normal project in ME326-Intermediate Dynamics. This project requires students to accurately predict the trajectory of an object after being launched from a small wooden catapult. In addition, they are required to determine the forces and stresses at certain locations at the catapult during the launch.

Every MEA should include a "self-assessment" aspect. This allows students to check their work and see if their engineering analysis was correct. Currently, the students can check their analysis by seeing if their calculated launch distance corresponded with the actual distance on launch day. However, this self-assessment will be expanded by the instrumentation of strain gages and an accelerometer - allowing for the verification of predicted results with experimental data.



Figure 1. Catapult used in Dynamics courses.

## Implementation in Coursework

The catapult project is given to students in both Dynamics (ME212) and Intermediate Dynamics (ME326). Professors Dr. Brian Self and Dr. Jim Widmann have successfully implemented this project into ME212, and Dr. Self has used this project in ME326. In ME212, students are expected to correctly apply fundamental Dynamics principles to predict launch distance using hand calculations. In ME326, students apply the same principles using computer simulation, for a larger range of conditions. In a class that has no laboratory component at Cal Poly, this provides students with a real hands-on component for learning. Because the catapult is a physical object, no dimensions have to be "given" as in a book problem statement. Instead, students determine which parameters are necessary to solve the problem, and measure those parameters themselves. Some of these parameters include the dimensions of the catapult arm, dimension from pivot to ammo cup, and the height of the rubber band pin. Another important aspect that students may or may not account for is the behavior of the rubber band. Some students assume linear behavior, using an average spring constant for their theoretical model. Other students go as far as plotting a curve-fit to account for any nonlinearities in rubber band stiffness. This kind of open-ended aspect stimulates the kind of critical thinking lacking in many textbook problems.

### *ME212-Dynamics*

Students enrolled in Engineering Dynamics (ME212) are assigned the catapult MEA soon after the principles of projectile motion, work-energy, and angular momentum are presented in lecture. This activity is aimed to solidify these fundamental concepts in students. They are required to develop a model using hand calculations that will be applicable to conditions that will be specified later - during launch day. These conditions are: stopper pin angle and pull-back angle. Students should realize that their trajectory and distance traveled will be a function of these two variables. A target will be placed in front of the catapult during launch day. A required pin stopper angle will be specified, and students will have to adjust the pullback angle of the catapult - based on their model - in order to hit the target.

In addition to this application of their model on launch day, students complete a follow-up homework assignment which also uses the model. This homework assignment involves finding the force on the stopper pin using impulse-momentum. This allows students to connect an additional concept from lecture to their model.

### *ME326-Intermediate Dynamics*

The assignment in Intermediate Dynamics (ME326) builds upon the skills already developed in ME212, but includes the programming of the model into computer simulation. Students develop a generalized model for any pull-back angle or stopper pin angle, and input it into MatLab. The required outputs include: angular velocity, launch distance, and cross-sectional stress as a function of catapult arm angular position. The stress in the catapult arm is initially in compression because of the rubber band, but because of the centripetal acceleration, the stress

becomes tensile. By bringing in stress analysis, students can see the blended application of their strength of materials courses and dynamics courses.

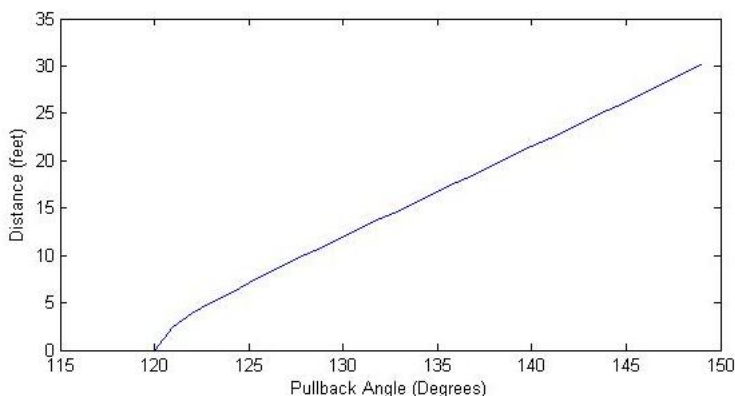


Figure 2. MatLab: Distance of projectile as a function of pull-back angle.

```

Command Window
>> CatapultCode
Enter the mass of the egg in lbs mass:
.15
Enter the stopping angle in degrees:
120
Enter the target distance in feet:
30
Your intial angle is:
    149
>> |

```

Figure 3. MatLab: Input window for MatLab script.

During launch day, students are given the constraints of pin stopper angle and required distance, which they input into their MatLab script. They then use the output of "required pull-back angle" from their program to try and hit the target. Students that successfully hit the target receive additional points on their deliverables.

### Observations

We have found that students from both courses enjoyed the hands-on aspect of this assignment. In addition, we have found that allowing students to test their models enables them to reveal both conceptual and mathematical errors. Diligent students record failed results from launch day and use them to further refine their model before turning in their deliverables. We plan on expanding upon this self-assessment by instrumenting the catapult. The process is outlined in the following section.

## Instrumentation Process

The objective of this instrumentation will be to expand upon this "self-assessment" principle of the MEA. Students will be able to cross-check their calculations with the instrumentation measurements during launch day. A two-axis accelerometer and two strain gages will be mounted on the catapult. With the accelerometer, the angular velocity of the arm can be found. With the strain gages, forces and stresses can be calculated at the corresponding gage mounting locations.

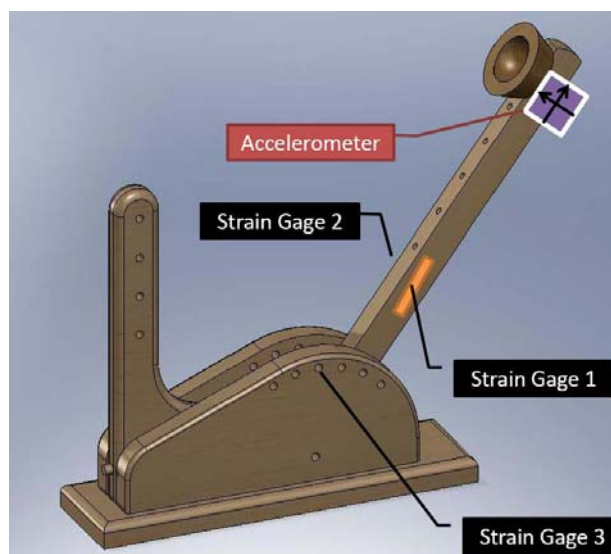


Figure 4. Catapult with associated instrumentation.

### Equipment:

- 1x AD22285-R2 Analog Devices 2-Axis Accelerometer
- 1x Strain Gage [Pin]
- 2x Strain Gages [Catapult Arm]
- DAC with LabView

### Accelerometer

The two-axis accelerometer will be mounted at the same distance as the ammo cup. This will allow the accelerometer to capture the tangential and normal accelerations of the to-be-projectile before it leaves the catapult arm. The x-axis of the accelerometer is oriented in the catapult arm's tangential direction of travel, while the y-axis is oriented in the arm's normal direction. Using the equations:

$$a_n = r\omega^2$$

$$a_t = r\alpha$$

where  $a_n$  and  $a_t$  are the measured quantities from the accelerometer, students will be able to determine the angular velocity and acceleration of the catapult arm over time. By integrating these values, angular position can be found, allowing the student to accurately produce a plot of experimental angular velocity as a function of catapult arm angle. This plot can then be compared to the theoretical model generated in MatLab.

### *Arm Strain Gages*

Two strain gages will be mounted on opposite faces of the catapult arm, parallel to the length of the arm. The gages will be wired in the same arm of a wheatstone bridge. This will allow for the measurement of axial strain of the arm, while ignoring any bending that may occur. The figure above shows the first iteration of strain gage placement. Note that there is a redundant strain gage on the edge of the arm, as well a strain gage that is not shown on the opposite side of the main catapult arm face.

### *Wood Elasticity*

Since wood is generally considered a nonlinear material compared to steel, to achieve an accurate result, the calibration of the strain gages may be necessary. The catapult arm, with attached strain gages, will be loaded with a known force, and the strain recorded. From this data set of static loading, we will determine a modulus of elasticity for the wood, which may be a function of the load.



**Figure 5. Initial Strain Gage Setup.** Gages C and A (not shown) measure axial stress in a half Wheatstone bridge. Gage B is a redundant gage that can potentially be used to capture bending.



Using this experimentally-obtained modulus of elasticity, along with the stress-strain relationship:

$$\sigma = E\varepsilon$$

the stress can be determined. Because we are calibrating the strain gage experimentally - recording load vs. strain - bi-axial strain will be accounted for.

### *Pin Gage*

Instrumentation to determine the force at the stopper pin as a function of time and/or angular position of the catapult arm would be beneficial. This information would provide for an additional self-assessment for students, who were required to determine the force at the pin using impulse-momentum. Initially, we planned on using a pin with a milled flat, which was perpendicular to the impact direction, to measure bending strain.

However, through some preliminary analysis and design iteration, we have concluded that this strain may be too small to measure. For now, we will focus on instrumenting the two strain-gages mounted on the catapult arm, as well as the 2-axis accelerometer.

### *Data Acquisition*

The standard data acquisition system currently being used in Cal Poly's "Experimental Methods" laboratory is applicable toward static loading only. Therefore an alternate method of acquisition must be developed. A LabView program will be used in order to sample strain gage and accelerometer readings with a very fast sampling rate. This system will simultaneously gather all necessary data, with a timestamp. In this manner, strain and acceleration of the desired locations can be determined as a function of time. From this data, angular velocity, acceleration, and strain can all be correlated as a function of angular position. Taking both strain gage and accelerometer readings simultaneously with the same device allows for seamless correlation between datasets, without the hassle of syncing data - as would be the case if separate data acquisition systems was to be used.

### **Conclusion**

Overall, we have found that the catapult project is a motivating learning activity for students. Because of both the hands-on and open-ended aspects, this project certainly solidifies the fundamentals of dynamics, while providing a venue to follow Cal Poly's "learn by doing" motto. By expanding the project with instrumentation, students will be able to quantify the dynamics of the physical experiment, and compare these results to their calculated predictions. This kind of self assessment allows students to connect their solution to the outside world, instead of just checking answers. We hope that this instrumentation will further motivate students in the years to come. Fire away.

## Acknowledgements

This work was funded by the NSF CCLI Grant #070607: *Collaborative Research: Improving Engineering Students' Learning Strategies Through Models and Modeling*.

## References

1. California Polytechnic University. (2009). *History*. Retrieved Thursday, March 05, 2009, from <http://lib.calpoly.edu/universityarchives/history/>
2. Dally, James W. (1993). *Instrumentation for Engineering Measurements*, (2<sup>nd</sup> ed.). New York, NY: John Wiley and Sons.
3. Meriam, J.L. & Kraige, L.G. (2002). *Engineering Mechanics Dynamics* (5<sup>th</sup> ed.). New York, NY: John Wiley and Sons.
4. Self, Brian P. (2001) *New Approaches in Teaching Undergraduate Dynamics*. Paper presented at the annual American Society of Engineering Education conference, 2001. Retrieved from the American Society of Engineering Education (ASEE) Web site: <http://soa.asee.org/paper/conference/paper-view.cfm?id=16211>

## Biographical Information

### Lawrence Fong

Lawrence Fong is a graduate student at Cal Poly, currently enrolled in the 4+1 blended BS+MS Mechanical Engineering program. As both a former tutor for Physics and grader for undergraduate studies, he is interested in improving upon the undergraduate program at Cal Poly. His thesis project involves expanding upon current curriculum to incorporate more hands-on learning and modeling exercises for Mechanical Engineering courses.

### Brian Self

Brian Self has been an Associate Professor at Cal Poly for the last three years. Before that, he taught at the Air Force Academy for seven years. He is the ASEE Campus Rep and the Zone IV Chair. Besides his pedagogical research, Dr Self is actively involved in aerospace physiology and biomechanics research. He has worked extensively to involve undergraduates in his research, taking students to present at national and international conferences. By involving students in solving ill-defined projects and problems that don't have a "correct answer", Dr Self hopes to further advance their intellectual curiosity and problem solving skills.

## Finite Element Analysis Tutorials for an Undergraduate Heat Transfer Course

Kyle A. Watson and Ashland O. Brown  
Department of Mechanical Engineering  
School of Engineering and Computer Science  
University of the Pacific  
3601 Pacific Ave., Stockton, CA 95211

### Abstract

Commercial finite element packages are widely used in industry thereby making exposure to this analysis and optimization tool an important component of undergraduate engineering education. Finite element analysis (FEA) tutorials have been developed for various undergraduate engineering courses, including mechanics of materials, vibrations, heat transfer, fluid mechanics, and machine design and analysis; these tutorials serve as an effective teaching and learning resource that reinforces the fundamental concepts and applications of each course. This paper discusses the implementation, results, impact, and assessment of incorporating steady-state and transient heat conduction tutorials into an undergraduate heat transfer course using SolidWorks and COSMOSWorks commercial software. The primary goals of these tutorials are to provide the students with (a) a different insight into the heat transfer concepts that are covered in a traditional undergraduate course, (b) a basic knowledge of finite element theory, and (c) the ability to apply commercial finite element software to engineering problems involving thermal systems. Assessment has been done through the use of pre- and post-tutorial quizzes, student opinion surveys, and demographic surveys of student learning styles. Furthermore, the implementation of a design project that involves an application of the knowledge gained from the tutorials is also discussed.

### Introduction

The finite element (FE) method is a widely used tool in industry for analyzing engineering problems. The most basic FE theory and applications are offered primarily as a graduate-level course, or in some cases, as an upper-level elective for undergraduate students. Therefore, the majority of engineering programs *do not require* coverage of FE theory and application as a component of their undergraduate curriculum. Industry is placing an increased emphasis on the ability to apply this powerful computational tool; so it follows that students earning an undergraduate degree in engineering should learn this skill in order to meet the demands of entry-level engineering job descriptions. The persistence of the deficiency of FE coverage in undergraduate engineering programs is due to various reasons, such as the recent focus on reducing credit-hours in engineering programs; the need to remove other material at the expense of adding this new material; and the fact that FE theory is very mathematics-intensive thereby making it more suitable for graduate students who have a more rigorous mathematical education. Nevertheless, there is clearly a need and curriculums should attempt to integrate this important component.

This paper discusses a mechanism for delivering FE instruction through the use of heat transfer tutorials that can be easily integrated into a *required* mechanical engineering course. The need for integrating FE theory and application across the engineering curriculum has been established and methods have been suggested by other authors<sup>1-2</sup>. **The primary focus of the current paper is to report the use of an instructional tool that would educate a broader spectrum of undergraduate engineering students with the basic knowledge of FE theory as applied to thermal analyses.** Furthermore, students using these tutorials will gain experience in applying commercial FE software to solve engineering problems. It should be emphasized that the focus of these tutorials is not to turn every engineering student into a FE expert.

More details of the NSF-funded CCLI project that this tutorial is a component of can be found elsewhere<sup>3</sup>; in short, instructional tutorials have been developed for several core engineering areas, including mechanics of materials, vibrations, heat transfer, fluid mechanics, and machine design and analysis. The current paper focuses in more detail on the heat transfer component of this project.

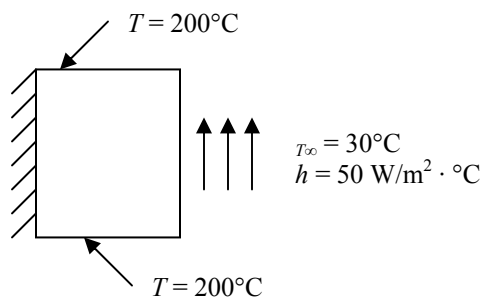
The educational goals of the heat transfer tutorials include the following:

- 1) to develop thermal FE tutorials that are easily accessible and require minimal instructor effort in order to integrate them into a required mechanical engineering undergraduate heat transfer course,
- 2) to provide undergraduate engineering students with a basic understanding of FE theory as applied to thermal analyses,
- 3) to provide undergraduate engineering students with an ability to apply commercial FE software in order to solve thermal engineering problems, and
- 4) to provide a different insight into the heat transfer concepts that are covered in a traditional undergraduate mechanical engineering heat transfer course.

### **Tutorial Summaries**

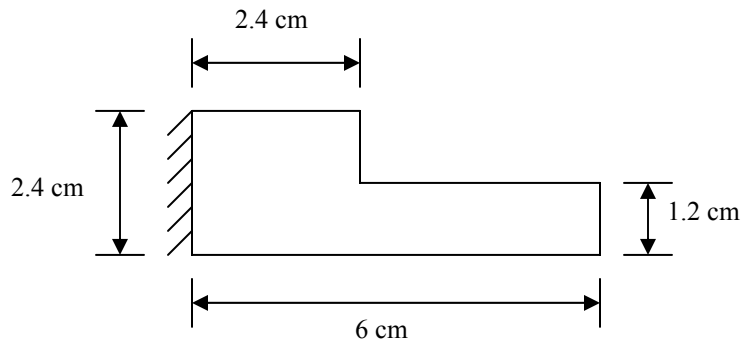
A steady-state heat conduction problem and a transient heat conduction problem were chosen as the basis for the two heat transfer tutorials. Problems were chosen that could also be solved relatively easily by hand calculations using numerical methods in order to allow for a comparison between the FEA solution and the hand calculations. The steady-state and transient heat conduction problems are summarized in Figs. 1 and 2, respectively. The steady-state problem was adopted from Chapter 4 (“Two-Dimensional, Steady-State Conduction”) of Incropera et al.’s textbook<sup>4</sup>, while the transient problem was adopted from Chapter 5 (“Numerical Methods in Heat Conduction”) of Çengel’s textbook<sup>5</sup>.

A long bar of rectangular cross-section ( $0.4 \text{ m} \times 0.6 \text{ m}$ ) with a thermal conductivity of  $k = 1.5 \text{ W/m} \cdot ^\circ\text{C}$ , is subjected to the following boundary conditions: two sides are maintained at  $200^\circ\text{C}$ , one side is insulated, and the remaining side is subjected to convection with the surrounding fluid at  $T_\infty = 30^\circ\text{C}$  and  $h = 50 \text{ W/m}^2 \cdot ^\circ\text{C}$ . Using a grid spacing of  $0.1 \text{ m}$ , determine the temperature distribution in the bar and the heat transfer rate between the bar and the fluid per unit length of the bar.



**Figure 1:** Steady-state heat conduction problem description (adopted from Incropera et al.<sup>4</sup>).

Consider two-dimensional transient heat transfer in an  $L$ -shaped solid body that is initially at a uniform temperature of  $90^\circ\text{C}$  and whose cross section is given in the figure below. The thermal conductivity and diffusivity of the body are  $k = 15 \text{ W/m} \cdot ^\circ\text{C}$  and  $\alpha = 3.2 \times 10^{-6} \text{ m}^2/\text{s}$ , respectively, and heat is generated in the body at a rate of  $\dot{e} = 2 \times 10^6 \text{ W/m}^3$ . The left surface of the body is insulated, and the bottom surface is maintained at a uniform temperature of  $90^\circ\text{C}$  at all times. At time  $t = 0$ , the entire top surface is subjected to convection to ambient air at  $T_\infty = 25^\circ\text{C}$  with a convection coefficient of  $h = 80 \text{ W/m}^2 \cdot ^\circ\text{C}$ , and the right surface is subjected to heat flux at a uniform rate of  $\dot{q}_R = 5000 \text{ W/m}^2$ . The nodal network of the problem consists of 15 equally spaced nodes with  $\Delta x = \Delta y = 1.2 \text{ cm}$ . Using the explicit method, determine the temperature at the top corner of the body after 1, 3, 5, 10, and 60 min.



**Figure 2:** Transient heat conduction problem description (adopted from Çengel<sup>5</sup>).

After the introduction of the problem statement, each tutorial includes the following major steps:

1. *Using SolidWorks to create a 3-D model.*

The steps required to draw the model in SolidWorks are summarized, including creating a two-dimensional sketch and extruding the sketch to make a 3-D object and dimensioning the 3-D object. These elements of the tutorial are presented such that a student with minimal background with SolidWorks will be able to model the problem.

2. *Submitting the model to COSMOSWorks.*

The steps required to open the 3-D object in COSMOSWorks and create a thermal study are summarized.

3. *Defining material properties.*

The steps required to assign the material properties which are necessary for a thermal analysis are summarized. Instructions for creating both custom-defined materials and common material types (aluminum, copper, etc.) are included.

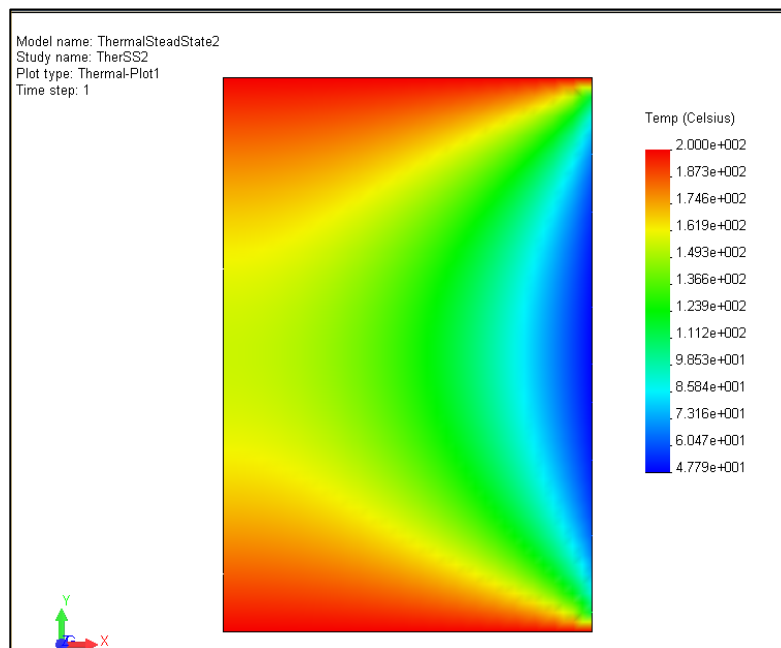
4. *Defining the transient analysis time increments and the time of study (transient tutorial).*  
The steps required to define the transient conditions are summarized including the total time of study and the time increment.
5. *Defining the thermal boundary conditions, initial condition (transient tutorial), and heat generation (transient tutorial).*  
The steps required to define the thermal boundary conditions are summarized, including convection, specified temperature, heat flux, and adiabatic (zero heat flux) conditions. The transient tutorial includes steps for defining the initial condition and a uniform heat generation throughout the entire volume of the 3-D object.
6. *Meshing the model.*  
The steps required to create a three-dimensional mesh using second-order tetrahedral solid elements type are summarized.
7. *Running the FEA.*  
The steps required to run the finite element analysis are summarized.
8. *Analyzing the results.*  
Information on post-processing the FEA results is included, including using a temperature probe to determine temperature values at points of interest and creating 3-D color plots. For reference, the temperature plots that are the primary output from COSMOSWorks are included in Fig. 3 for the steady-state tutorial and in Fig. 4 for the transient tutorial
9. *Finite Element Analysis Theory.*  
As an appendix to the tutorials, background information on FEA theory is included; this material is aimed at students with minimal knowledge of FEA. Concepts such as element types and the effects of mesh size on the results are discussed, in addition to a list of references for more information on FEA theory.

## **Implementation**

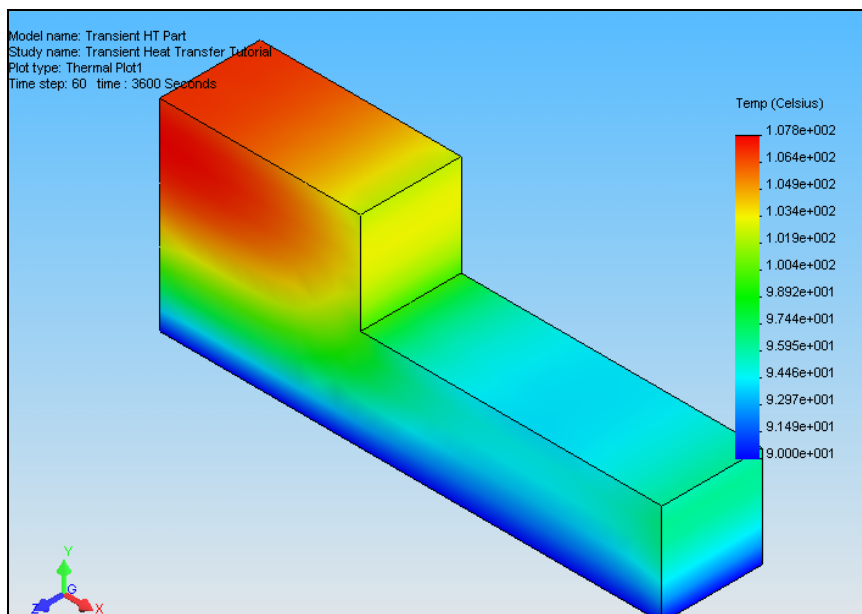
The steady-state and transient tutorials discussed above have been incorporated into an undergraduate heat transfer course at the University of the Pacific. The majority of students in this class have taken a course in SolidWorks, but this is not required since the tutorials are written such that no familiarity with SolidWorks is necessary. The topic of numerical methods in heat conduction is covered before the tutorials are used. Specifically, finite difference techniques for one- and two-dimensional steady-state and transient heat conduction are covered in class; Chapter 5 (“Numerical Methods in Heat Conduction”) of Çengel’s textbook<sup>5</sup> is used as a reference in covering this material. With this knowledge, students are able to solve the tutorial problems by hand and ultimately compare the FEA output with these hand calculations. To further demonstrate the principles learned by the tutorials, additional homework problems have been assigned, such as those included in Fig. 5 for steady-state heat conduction (Incropera et al.<sup>4</sup>) and in Fig. 6, which is directly related to the transient heat conduction tutorial problem described in Fig. 2.



Finally, a thermal design project has been implemented into the heat transfer course at the University of the Pacific where the students are required to apply the knowledge gained from the tutorials. In summary, the students are required to come up with a design that will meet the specified requirements by creating a 3-D computer model, submitting the model to COSMOSWorks, and analyzing the FEA output. These design projects are especially powerful in demonstrating the concept of optimization.

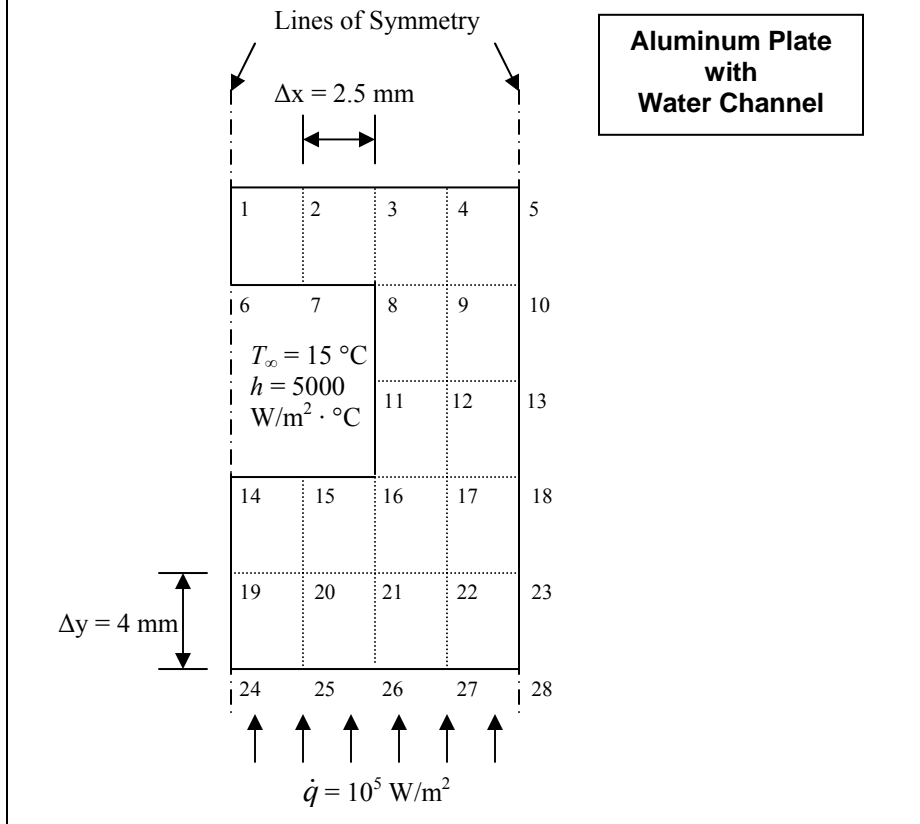


**Figure 3:** Temperature plot for the steady-state tutorial problem described in Fig. 1.



**Figure 4:** Temperature plot for the transient tutorial problem described in Fig. 2.

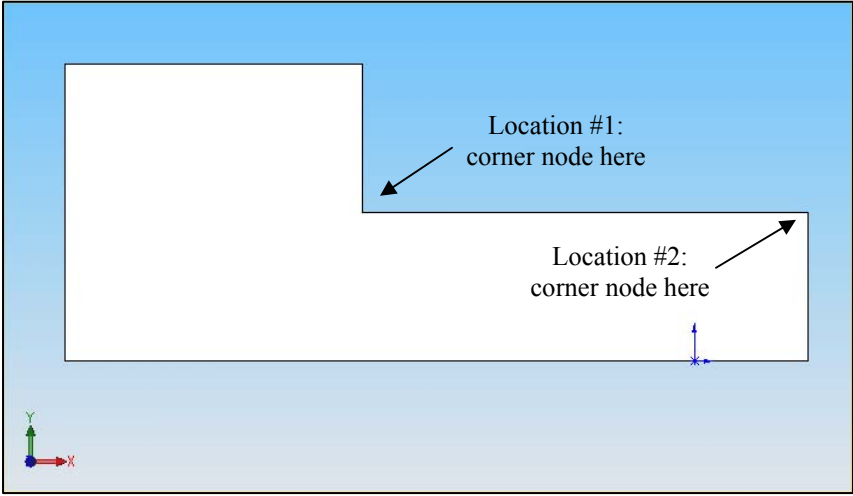
An aluminum plate ( $k = 190 \text{ W/m} \cdot ^\circ\text{C}$ ) is in contact with a chip dissipating power. To cool the plate, water is passed through regularly-spaced rectangular channels within the plate. Power dissipation within the chip results in a uniform heat flux of  $\dot{q} = 10^5 \text{ W/m}^2$  at the base of the plate, while the water flow provides a temperature of  $T_\infty = 15 \text{ }^\circ\text{C}$  and a heat transfer coefficient of  $h = 5000 \text{ W/m}^2 \cdot ^\circ\text{C}$  within the channels. Assuming the top surface of the plate is insulated, utilize symmetry and the nodal network below to solve for the steady-state temperature distribution within the plate by (a) hand calculations and (b) using COSMOSWorks computational finite element analysis. Compare the results at a few key points on the plate.



**Figure 5:** An additional steady-state heat conduction problem (adopted from Incropera et al.<sup>4</sup>).

Perform the “Transient Thermal Finite Element Analysis Tutorial” (see problem described in Fig. 2) for COSMOSWorks and complete the following:

- Create plots of the temperature (in °C) versus time at the corner nodes shown below (Location #1 and Location #2).
- Create temperature plots of the entire bar at 1 minute and 10 minutes.
- Repeat part *b*) for  $k = 1.5 \text{ W/m}\cdot\text{K}$  and comment on the comparison between parts *b*) and *c*).



The diagram shows a stepped bar with a white rectangular section on the left and a blue rectangular section on the right. The blue section is narrower than the white section. Two corner nodes are identified: 'Location #1: corner node here' at the top-left corner of the blue section, and 'Location #2: corner node here' at the top-right corner of the blue section. A coordinate system is shown at the bottom left with X, Y, and Z axes.

**Figure 6:** An additional transient heat conduction problem which is an extension of the problem described in Fig. 2 and used in the transient heat transfer tutorial.

## Assessment

The primary method for assessing the success of the heat transfer tutorials is the use of pre- and post-tutorial quizzes. These quizzes were designed primarily to assess the success of the tutorials in meeting the goal of reinforcing the concepts that are covered in a traditional undergraduate mechanical engineering heat transfer course by providing a more visual and “hands-on” insight. The quiz consists of eight questions related primarily to the concept of heat conduction through a solid body and the application of Fourier’s Law of heat conduction (see Appendix A). The same quiz is administered pre- and post-tutorial and the results are tracked for each individual student. During the spring 2008 semester, among 19 students the average quiz score improved from 63.2% pre-tutorial to 72.4% post-tutorial, showing a 14.6% improvement. Furthermore, of the 19 students, 12 showed improvement, 5 attained the same result, and 2 showed a decrease in quiz score. Information from demographic data sheets, Myers-Briggs personality profiles (<http://www.humanmetrics.com/cgi-win/JTypes2.asp>), and the Felder-Silverman Index of Learning Styles

(<http://www.engr.ncsu.edu/learningstyles/ilsweb.html>) were also gathered for each student in an attempt to correlate the success of the tutorials for different learning styles. More information about these assessment tools and their use in this study can be found in Brown et al.<sup>3</sup>.

## **Conclusions**

This paper reports the use of heat transfer tutorials in a required mechanical engineering undergraduate heat transfer course. Increasing industry demand for graduates to have the ability to use and apply commercial FE packages has created a need for integrating FE instruction into the undergraduate engineering curriculum. These tutorials provide a tool for easily implementing the FE method and application into the curriculum in order to provide a basic understanding of FE theory as applied to thermal analyses. Additional tutorials have been developed for other core engineering areas making the use of these tutorials across the engineering curriculum an excellent means for providing substantial coverage of the FE method. Furthermore, results suggest that these tutorials aid in reinforcing the basic heat transfer concepts covered by traditional lecture material.

## **Acknowledgement**

This work is partially supported by the National Science Foundation three year grant DUE CCLI Award Number 0536197.

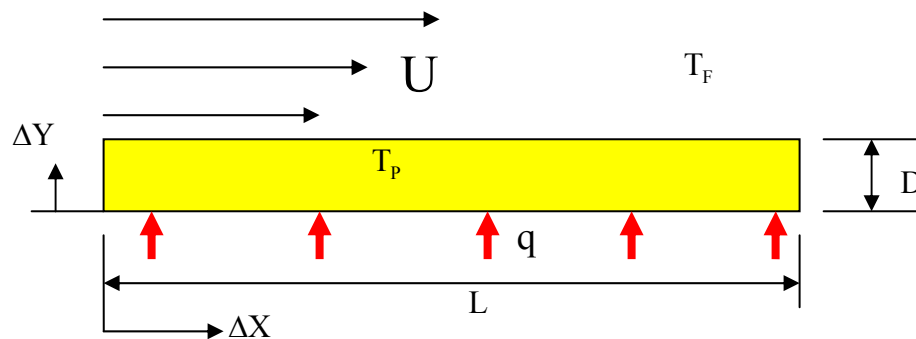
## Appendix A (Pre- and Post-Tutorial Quiz)

### Heat Transfer/Numerical Methods Basic Knowledge (Pre/Post to completing the Two Heat Transfer Tutorials)

Your student ID is used only to match up your heat transfer basic knowledge prior to completing the finite element heat transfer tutorial and after completion of the tutorials. We will not correlate your knowledge or responses with your name or use in assessing your grade. Thank you in advance for your cooperation in our research efforts to improve learning under this NSF Grant. Prof. Ashland O. Brown

Pacific Identification Number: \_\_\_\_\_

We have a cross-section of a flat plate being heated from below with a constant flux  $q$  in an air stream with an average velocity  $U$ . We will assume the heat transfer is only one dimensional in the  $Y$  direction of this plate.



- |  |   |
|--|---|
| $T_F$ - air stream fluid temperature           | $Q_{\text{conduction}}$ - 1-D conduction in Y-dir |
| $T_p$ - plate temperature                      | $c_p$ - specific heat at constant pressure        |
| $L$ - plate length                             | $\alpha$ - thermal diffusivity                    |
| $D$ - plate height                             | $\rho$ - density                                  |
| $h$ - convection heat transfer coefficient     |   |
| $k$ - thermal conductivity of the plate        |   |
| $q$ - uniform heat flux                        |   |
| $A$ - surface area of the plate into the paper |   |

1. Define the rate of heat conduction in the  $Y$  direction for the plate between the two points 1 on the plate surface and 2 on underside of the plate. (circle the correct formulation)

$$Q_{\text{Conduction}} = k A (T_{p1} - T_{p2}) \quad Q_{\text{Conductin}} = -kA \frac{(T_{p1} - T_{p2})}{D}$$

$$Q_{\text{Conduction}} = -k \frac{D(T_{p1} - T_{p2})}{A}$$

2. Thermal diffusivity  $\alpha$  is used in a transient thermal analysis and represents how fast heat diffuses through a material and would have the following formulation: (circle the correct formulation)

$$\alpha = \frac{Ak}{c_p} \quad \alpha = \frac{k}{\rho \cdot c_p} \quad \alpha = \frac{\mu \cdot k}{\rho} \quad \alpha = \frac{hA}{k}$$

3. Define the rate of convection (Newton's Law of cooling) in the Y direction from the plate between a point in the air flow stream and a point 1 on the surface of the plate.

$$Q_{\text{Conv}} = hD(T_F - T_{P1}) \quad Q_{\text{Conv}} = \frac{h}{k}(T_F - T_{P1}) \quad Q_{\text{Conv}} = hA(T_F - T_{P1})$$

4. If there is a temperature gradient between the top and bottom of the plate, and we hold the heat flux constant but increase the air stream average flow velocity this plate temperature gradient would: (assume constant material and air properties)

Increase                      Decrease                      Remain the same

5. If there is a temperature gradient between the top and bottom of the plate, and we hold the air velocity fixed, but increase the heat flux rate to the bottom of the plate we would expect the plate surface temperature to: (assume constant material and air properties)

Increase                      Decrease                      Remain the same

6. If we performed a heat balance of the conduction through the plate and the convection from the plate's surface and used the thermal resistance concept our formulation for the steady rate of heat transfer through the plate would be:

$$Q = \frac{\Delta T_{\text{plate}}}{hkA} \quad Q = \frac{\Delta T_{\text{plate}} \cdot D}{kA} \quad Q = \frac{\Delta T_{\text{plate}}}{\frac{1}{hA} + \frac{D}{kA}}$$

7. The finite element method of modeling heat transfer in the plate approximates the differential equations with \_\_\_\_\_ of equations.

a. finite differences    b. nodal models    c. linear arrays    d. finite numbers

8. An object is undergoing transient heat conduction. If the thermal conductivity of the object is decreased by changing the material, the object will reach a steady-state temperature distribution:

a. faster    b. slower    c. in the same amount of time

## Bibliography

1. Baker, J. R., Capece, V. R., and Lee, R. J., "Integration of Finite Element Software in Undergraduate Engineering Courses," *Proceedings of the 2001 American Society for Engineering Education Annual Conference and Exposition*, 2001.
2. Sorby, S. A., Walker, G., Yano, M., Glozman, V., Kochersberger, K., Mathers, J., McKinney, J., Schulman, J., and Young, M., "Modernization of the Mechanical Engineering Curriculum and Guidelines for Computer-Aided Engineering Instruction," *Computer Applications in Engineering Education*, Vol. 7, pp. 252-260, 1999.
3. Brown, A. O., Rencis, J. J., Jensen, D., Chen, C. C., Ibrahim, E., Labay, V., and Schimpf, P., "Finite Element Learning Modules for Undergraduate Engineering Topics Using Commercial Software," *Proceedings of the 2008 American Society for Engineering Education Annual Conference and Exposition*, 2008.
4. Incropera, F. P., DeWitt, D. P., Bergman, T. L., and Lavine, A. S., *Introduction to Heat Transfer*, 5<sup>th</sup> Ed., John Wiley & Sons, Inc., 2007.
5. Çengel, Y. A., *Heat and Mass Transfer: A Practical Approach*, 3<sup>rd</sup> Ed., McGraw-Hill, 2007.

## Biographical Information

### **Kyle A. Watson, University of the Pacific**

Kyle A. Watson is an assistant professor of mechanical engineering at the University of the Pacific. He has served in that position since 2003 and has taught undergraduate courses in thermodynamics, heat transfer, combustion, air-conditioning, dynamics, capstone design, and introduction to engineering. He received his B.S. in Mechanical Engineering from Villanova University and M.S. and Ph.D. in Mechanical Engineering from North Carolina State University. He has published numerous journal articles in the areas of experimental combustion science and engineering pedagogy.

### **Ashland O. Brown, University of the Pacific**

Ashland O. Brown is a professor of mechanical engineering at the University of the Pacific in Stockton, CA. He has held numerous administrative, management and research positions including Program Director, Engineering Directorate, National Science Foundation; Dean of Engineering at the University of the Pacific; Dean of Engineering Technology at South Carolina State University; Engineering Group Manager at General Motors Corporation; Principal Engineering Supervisor, Ford Motor Company; and Research Engineer, Eastman Kodak Company. He received his B.S. in Mechanical Engineering from Purdue University and M.S. and Ph.D. in Mechanical Engineering from the University of Connecticut. He has authored over 40 referred and propriety publications in automotive design, finite element modeling of automobile body structures, and photographic film emulsion coating instabilities. His most recent research includes development of innovative finite element tutorials for undergraduate engineering students and vibration analysis and measurement of human skeletal muscles under stress using laser holography.

## The Role of Computing in Education: The Next Revolution

Frederick Harris  
Dept. of Computer Science  
University of Nevada at Reno  
Reno, Nevada 89512

Gordon Lee  
Dept. of Elect & Comp Engr  
San Diego State University  
San Diego, CA 92182

Stuart H. Rubin  
SPAWAR SSC San Diego  
53560 Hull Street  
San Diego, CA 92152

T.C. Ting  
Dept. of Comp Sc and Engr  
University of Connecticut  
Storrs, Connecticut 06269

Billy Gaston  
Research & Development  
Anautics, Inc.  
Oklahoma City, OK 73110

Gongzhu Hu  
Dept. of Computer Science University of  
Central Michigan University  
Mount Pleasant, MI 48859

### *Abstract*

As computing technologies continue to rapidly advance, the knowledge economy also continues to be a more important part of the world economy. Ubiquitous computing is here to stay and it has become one of the main fibers of social, cultural, and economical life. It is an enabling technology that can increase the productivity in a wide range of applications and economical activities. Besides economic growth potential, computing also provides an opportunity for educational growth; this paper represents a summary of the discussions of researchers from industry, government and academia who were assembled to address how this evolution of computing can impact education in the next revolution.

### 1. Introduction

The concept of *computing* has been continuously evolving. In the early 1980s, it was the marriage of computing and communication technologies that created the era of internet-based information resources that continues to affect and penetrate into our daily activities through information accessing. Currently, this polygamy of computing, communication, storage, sensory and displaying technologies impacts almost all social, cultural, and economical development as well as our daily life. That is, the impact of computing places a multitude of opportunities into the homes and control of ordinary people, thus enhancing lives on a global scale. This phenomenon can be seen with the widespread use of the telephone, computers, electronic databases and the internet. The telephone provides a platform for communication, the computer provides computing power to the individual, database systems provide a place to store and organize data efficiently, and the internet provides a wide-scale platform for the searching for solutions. The world continues to benefit from enhanced global communication, data organization and retrieval, and computing. These technologies have greatly affected the economy of countries that are able to properly leverage them without extreme restrictions. Technologies have enabled individuals, small groups, and small countries to have an equal voice by providing as much access, visibility and opportunities as large businesses and advanced countries.

One of the major impacts of computing is in the area of human learning, that is, cognitive and logical inference activities that will inevitably change the way we learn, work and live [1]. Lifelong learning will be the focus for long term and continuous economical development. In a report from the European Parliament and the Council on Key Competences for Lifelong



Learning [2], “digital competence” and “learning to learn” are among eight key competences for citizens in order to easily adapt to a rapid changing and highly interconnected world.

The importance of computing and computers in engineering education has been known for several years and several educators have shared their experiences and activities in this regard. For example, in [3-5], engineering education researchers in the disciplines of civil engineering and computational science have developed special software tools which enhance the academic environment. These computer-based instructional guides supplement the teacher in the classroom by providing design examples, additional practice problems in the computational aspects of the field, and self-paced learning.

Further, researchers realize the power of the web as a learning tool [6-7, for example]. Through the web, students and teachers are able to draw upon the vast database of information available through a flexible and global media.

The purpose of this paper is to support the claim that computing continues to have a major impact in engineering education as well as to project how computing can provide an even greater influence in engineering education through digital tutors and web-based learning. The paper is organized as follows: Section 2 provides some information on the current state of education in the US which warrants the need for improvement which Section 3 discusses the challenges in using computing to address the shortcomings in the current educational environment. In Section 4, one option is presented, the KASER, as a platform to assist with the educational reform using computing and, in Section 5, we summarize how we as educators can support the new educational revolution using computing.

## **2. The Current Educational Situation**

Several countries have already recognized the value of education as an integral component of economic growth; these countries place great emphases on education, particularly in fields where there is a large gap between the availability of skilled workers and market demands (e.g., the STEM disciplines – science, technology, engineering, and mathematics). There is a large disparity in the quality of mathematics and science education amongst countries. When compared to many other countries, the educational system in the U.S. is lacking more and more in preparing students for the transition from high school to college and from college to industry as is shown below.

With reference to the Global IT Report for academic year 2007-2008 [8], the countries ranked in the top ten in mathematics and science education are listed in Table 1. The scores in the table were based on the World Economic Forum Executive Opinion Survey 2006–2007 survey data (where 1 = lags far behind most other countries and 7 = are amongst the best in the world).

One observes that the United States is not in the top ten and is, in fact, ranked 43th. There has been a coordinated effort from government, academia, and industry in the U.S. to improve and reform the education systems to put greater emphasis on STEM education at the precollege levels to attract more young people into these fields. Several U.S. government agencies,

including the Department of Education and the National Science Foundation, have been actively promoting STEM education. Yet, there is still a large disparity between the performance of US students and other countries.

**Table 1.** Quality of Math and Science Education [8]

Rank	Country/Region	Score
1	Singapore	6.34
2	Belgium	6.29
3	Finland	6.17
4	Hong Kong SAR	5.85
5	Switzerland	5.72
6	France	5.71
7	Tunisia	5.62
8	Taiwan, China	5.59
9	Czech Republic	5.53
10	Korea	5.46

The result of the Global IT Report is not the only indicator that the U.S educational system is failing. The failure rates are staggering; over 1,000,000 students drop out of school each year [9] and many of those students who do graduate are still ill-prepared for the workforce. With the shrinking budget and limited resources, educational reform can best be served by computer-based training, which is vital to our national economic infrastructure in the medium term on out. Success in educational reform is contingent upon success in computational creativity. It is noted that many details and justifications for this premise are necessarily omitted from this paper for the sake of brevity.

The then Presidential-candidate Barack Obama said on October 15, 2008 that no nation in history has ever maintained a strong military in the absence of fiscal solvency [10]. One aspect of fiscal solvency is a relatively full employment, in keeping with the Phillips curve (i.e., allowing for 4 percent unemployment) [11]. But this is not the complete picture. We need to maintain and thus invest in an evermore educated workforce to remain economically competitive in the global economy. How do we do this? This responsibility was given to the schools which had the main role of education. However in the current form of our educational system, schools can not effectively reach students under the current or foreseeable budget. What is needed is the introduction of affordable computer technologies to capture good instructional practice to deliver quality education to each and every individual where it is needed and when it is needed. This form of education can support and supplement our educational system thereby reducing the resources strain that is currently afflicting our schools.

### 3. Challenges in Computing

Computing will continue to impact the economy in the years to come. To sustain such an impact, we will need to address several issues concerning the development of computing technologies [1]:

- (1) It should be a technology that fosters more collaboration with others versus one that removes human interaction and social development, unless human life is at stake.
- (2) Researchers must be careful to determine if efforts should be focused on leveraging technology to think for us, to interpret and understand for us, to instruct us, or to predict/forecast the future for us. Some may deem that as creating a sort of god for mankind.
- (3) One must ensure that technology not prevent users from knowing and experiencing fundamental concepts and learning experiences.
- (4) The technology should enable the enhancement of communication, computing, production, and thus economic opportunities. It is important to leverage this enhancement byproduct without eliminating the fundamental skills that should be learned by an individual. It can be stated with caution that, knowing that computing is changing the human society, what was once noted as fundamental in one age may be obsolete in another; it is suggested that the domain of fundamental skills is in a gradual process of re-definition.

#### 4. The Next Revolution

What areas will provide the basis for the next revolution in technology? Computing power, communication, storage capability and collaboration techniques provide some insight in addressing this question. These areas are driven by the immense need to access, analyze, process, and distribute information more intelligently. *Information* is the common denominator which is also the main denominator in education. It is sometimes said that information/knowledge is power; however, it should be correctly stated that applied information/knowledge is power, assuming that the information being applied is of the necessary quality.

Over the past few years, steps have been taken by a number of government and commercial entities to capture data to address the issue of providing a more informative, preventative and predictive analysis. Unfortunately, whether it is historical data stored in legacy systems, current data captured by mechanics, or future data acquired by the use of sensor technology, some of the underlined issues still remain. These issues include, but are not limited to, making sense of the captured data, acquiring the appropriate combinations of data, making the proper relationships between data, as well as determining the relevance of said data.

One of the biggest problems of data collection is determining what exactly one can keep and/or disregard. This creates a problem in an unnecessary cost of storage, which can be high when processing a large amount of data. Discovering and defining relationships between similar documents or sets of information have become rather common and needs to be addressed within all areas of government, business and industry. Entities needing this capability range from potentially small scale systems, such as a small elementary school library book management systems, to large scale systems, such as military government information systems servicing several international logistic depots. The *right information* is often needed to obtain real time situational awareness, mission capability, damage assessment, and risk analysis. These issues affect all types of business and government organizations and may prove beneficial in business decisions, medical discoveries, advances in information retrieval and organization, environmental management, aircraft maintenance management and the like. The same principles apply in education.

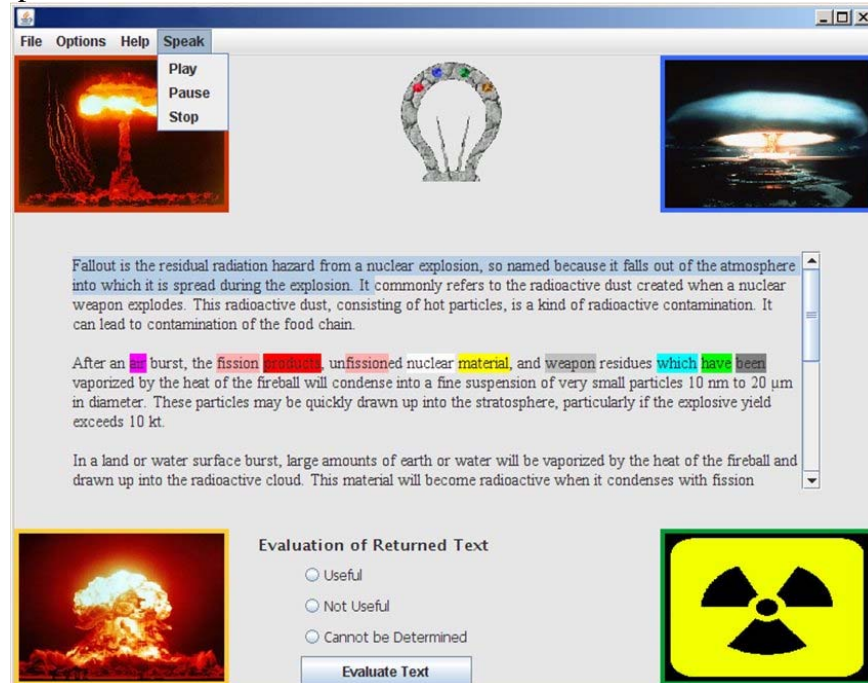
Throughout the business world, whether commercial or noncommercial, there exists the need for a solution that can capture input from disparate data sources, analyze the information, discover new information of relevance, link related information, and from said information allow the necessary personnel to make intelligible decisions. The term “necessary” is used because such a solution should possess the capability to adapt the distributed information to each end-user based on ability, role, clearance, learning capacity, and level of need. This involves some knowledge and interaction with the user. This technology should enable intelligent information access and interaction and not information overload. Specifically it should provide the necessary understanding to make optimal decisions and not hinder decision making.

How can this revolution impact education? Again, *information* access is the key. We believe that the next revolution in education will be the instant access to global information. The vast majority of intelligent tutors and trainers these days have good graphics and multimedia support. They are lacking in intelligence, however. It is our opinion that the best architecture for delivering intelligence in tutoring and training applications is to arrange all multimedia materials as small objects that are maintained in an object-oriented relational database and brought up by a simple rule-based production system. The input to this expert system can be quiz questions (even connected to simulation programs), meant to elicit student feedback. The pattern of responses serves as the context to the intelligent system. While such a system can be prototyped and will certainly work, there is a problem.

At this point, we need to introduce the concept of the KASER family of intelligent systems [12]. The KASER is a knowledge amplifier (the acronym stands for *Knowledge Amplification by Structural Expert Randomization*) based on the principle of randomization. This principle refers to the use of fundamental knowledge in the capture and reduction of a larger, dependent space of knowledge (not excluding self-reference). KASERs allow for the definition of computational architectures that allow for the delivery of educational content in a reusable, augmentable, cost effective manner that offers to make text-based instruction all but obsolete. Key actions to enhance e-skills readiness are shown in Table 2 [13].

With the use of KASERs, information searching, for example, will be an accelerated learning experience between pupil *and* the knowledge-base. Such systems can learn from user feedback; by minimizing the system training required of the knowledge engineer, we can more effectively process vast free-text databases of knowledge for minimal development cost. Furthermore, these bases may be concurrently created and maintained and search algorithms can run on parallel processors connected in heterogeneous distributed networks. Imagine a student coming home from a physics class in need of more explanation on how to compute the angle of an arrow to maximize the distance to a target. She could simply access her digital tutor, ask the question and gain access to web sites, videos and pdf files on the subject. Some sites may be irrelevant while other provide detailed graphics to enhance the learning. Figure 1 illustrates an example of what a web search may be using the KASER to say search for information on radiation blasts and the fallout for a student term paper.

Further, learning is a lifelong experience; it is through computing that we can enhance this learning experience!



**Figure 1:** Example of the use of a KASER to Perform a Web Search

## 5. New Directions in Computing

In the competitive world, a strong cooperation between government, academia, and industry play a vital role critical to the health and prosperity of our economies and to improve the quality of life of our citizens. Bruno Lanvin suggested five key actions to take in work force enhancement [13], as shown in Table 2.

Although the five key actions above were targeted to the European Union, we believe they are also universally applicable to other countries including the U.S. As researchers and practitioners in the field of computing, we are an integral part of the national and international coordinated effort for the advancement of computing to sustain economic growth.

In particular, the following points highlight what the research community in computing should do in the next decade [1]:

- (1) Develop more focused efforts.
- (2) Specifically market government and commercial businesses to come to conferences (e.g. provide discount registration, create incentives for teaming with universities, and encourage program committees to include industry partners).
- (3) Team with small businesses. Small businesses are positioned to create cost effective solutions, more innovation, and more enhanced/focused solutions. There is funding specifically set aside for small business and university research teaming.

- (4) Lobby to prevent government intervention without understanding.
- (5) Much more research in security and confidentiality areas need to be emphasized.
- (6) Standards and compatibility for the massively connected computational and information processing systems need more research and more attention to policies for the information oriented and dependent society.
- (7) Research in intelligent information processing need to focus on holistically and symbiotically for both static and dynamic data and knowledge.
- (8) Software efficiency and reliability including systems as well as application software systems need to be emphasized.
- (9) Intelligent and logical user/system interaction, including multimedia and sensory interfaces needs to be greatly improved and developed.
- (10) Representatives from computing research and development communities need to be engaged, more actively participating in policy, legal, and regulatory processes.
- (11) Most importantly, we need to actively engage in the development learning strategies and activities in schools as well as in society for preparing individuals for effective use of computing and information systems for learning and working in our current and future information oriented society.

**Table 2:** Actions and Drivers in the Next Revolution [13]

Key Action	Expected Leader
Share a compelling vision	government
Strengthen skills	government (visibility) industry (inclusion, action)
Formulate curricula	industry (needs) academia (formulation) government (regulatory)
Promote math and science	academia (curricula) government (vision) industry (sponsoring)
Enhance lifelong learning	industry (content, rewards) government (fiscal) academia (e-learning)

## 6. Conclusions

On the education front, we as researchers and educators need to be creative. Old instructional presentation formats do not work any better than do fixed micro-managed lesson plans. Due to shrinking budgets and over-burdened teachers, it is critical that we develop new paradigms to address the challenges in our educational system.

Computing provides a solution which can supplement our educational environment through creative and intelligent architectures. We must effectively use computers to augment our intellectual capabilities throughout the life. A revolution is required and only through this activity can we continue to grow economically and more importantly intellectually.

## 7. References

- [1] F. Harris, G. Lee, S.H. Rubin, T.C. Ting, B. Gaston, and G. Hu, "The Impact of Computing on the World Economy: A Position Paper", *Proc. of the ISCA Int'l Conference on Computers and Their Applications*, New Orleans, 2009.
- [2] "Recommendations of the Europe Parliament and the Council of 18 December 2006 on Key Competences for Lifelong Learning", *Official Journal of the European Union*, Vol. 394, pp.10–18, December 2006.
- [3] L. Wills and S. Wills, "MiSaSiM: A Resource-Aware Programming Environment for Computer Systems Engineering Education", *Proceedings of the 37th ASEE/IEEE Frontiers in Education Conference*, Milwaukee, 2007.
- [4] O. Abudayyeh, H. Cai, S.J. Fenves, K. Law, R. O'Neill, and W. Radorf, "Assessment of the Computing Component of Civil Engineering Education", *Journal of Computing in Civil Engineering*, Vol. 18, No. 3, pp. 187-195, July 2004.
- [5] B.G. Singley, R. Hotchkiss, and J. McDonald, "Computer-Based Instruction for Engineering Education in the Developing World", *Proceedings of the ASEE Annual Conference and Exposition*, Pittsburgh, 2008
- [6] S.R. Balasundaram and B. Ramadoss, "Learning and Assessment Using Pervasive Computing for Web-Based Engineering Education", *Proceedings of the 7th International Conference on Information Technology Based Higher Education and Training*, Sydney, 2006.
- [7] T. Marchioro II and R.H. Landau, "Web-Based Education in Computational Science and Engineering", *IEEE Computational Science & Engineering*, Vol. 4, No. 2, pp. 19-26, Apr-Jun, 1997.
- [8] World Economy Forum, "The Global Information Technology Report 20072008", <http://www.weforum.org/en/initiatives/gcp/Global%20Information%20Technology%20Report/index.htm>, 2008.
- [9] B. Wehling and Carri Schneider (Eds.), *Building a 21<sup>st</sup> Century U.S. Education System*", *National Commission on Teaching and America's Future*, 2007, [http://www.nctaf.org/resources/research\\_and\\_reports/nctaf\\_research\\_reports/Buildinga21stcenturyu.s.education.system.htm](http://www.nctaf.org/resources/research_and_reports/nctaf_research_reports/Buildinga21stcenturyu.s.education.system.htm).
- [10] B. Obama, "Remarks in Londonderry, New Hampshire: October 15, 2008", [http://www.presidency.ucsb.edu/2008\\_election\\_speeches.php?candidate=44](http://www.presidency.ucsb.edu/2008_election_speeches.php?candidate=44)

- [11] A. W. Phillips, “The Relationship between Unemployment and the Rate of Change of Money Wages in the United Kingdom: 1861-1957”, *Economica*, Vol. 25, No. 100, pp. 283–299, 1958.
- [12] S. Rubin, S. N. J. Murthy, M. H. Smith, and L. Trajkovic, “KASER: Knowledge Amplification by Structured Expert Randomization”, *IEEE Transactions on System, Man, and Cybernetics — Part B: Cybernetics*, Vol. 34, No. 6, pp. 2317–2329, 2004.
- [13] B. Lanvin, “Competitiveness and Employability: Knowledge Societies’ Next Frontier”, *Proceedings of the European e-Skills Conference*, 2008.



## Potential Value of Toys in Engineering Education

Said Shakerin, Ph.D., P.E.  
 School of Engineering and Computer Science  
 University of the Pacific, Stockton, CA 95211  
[sshakerin@pacific.edu](mailto:sshakerin@pacific.edu)

### Introduction

Classroom demonstrations add to students' interest and their understanding of the subject matter. Many references are available that deal with demonstrations, for example in physics courses<sup>1-4</sup> and engineering<sup>5-6</sup>. A wide variety of apparatuses and processes have been developed or adapted for demonstrations; these range from simple to complex, inexpensive and homemade devices to elaborate, expensive and commercially available units. Children's toys and the so called "executive toys" or novelties have also been employed as demonstration tools<sup>7-10</sup>. Properly selected toys offer at least three advantages: (1) they are relatively inexpensive and readily available for immediate use; (2) there is a good chance that students are familiar with them from their own experiences; and (3) they exhibit a wide variety of scientific concepts. In addition to their utility for classroom demonstrations, toys can be used for other educational purposes such as informal science education and inspiring ideas for student projects.

The literature on toys in education is indeed rich, especially in publications such as *American Journal of Physics*, *The Physics Teacher*, and the European journal *Physics Education*. Since engineering fundamentals are extensions of those of physics, the paper on toys written by colleagues in physics could well be relevant and applicable to our profession. Most of the toys discussed in the literature are related to aspects of solid mechanics, popular and well know toys like the top, yo-yo, gyroscope, slinky, balancing toy, buzzing magnets, rattle disk, Euler's disk, etc. An online search for physics of toys will reveal adequate number of links to get an interested reader on a journey to learn more, however, two excellent papers are included here for completeness<sup>11-12</sup>.

Some of the toys discussed in the literature are related to fluid mechanics. Probably the oldest one and the most frequently written about "fluids toy" is the Cartesian diver, a floating object in a bottle of water that can be moved up or down based on the force exerted on the bottle, that demonstrates hydrostatic pressure and buoyancy. Its use has been documented as early as the 17<sup>th</sup> century<sup>13</sup>, but interestingly it has continued to the present day in several forms and modifications<sup>14-17</sup>. Another popular toy is the drinking bird, an oscillating bird that seems to take small sips of water by tilting down to make a contact between its felt-covered beak and water in a glass and up, and repeating this cycle for quite a long time, demonstrating evaporation and center of gravity<sup>18-19</sup>. A wonderful old toy is the putt-putt boat which demonstrates the third law of Newton among other phenomena it exhibits<sup>20-22</sup>. Slime and silly putty are also child's toys that have remained popular for several decades as gooey and deformable substances with strange rheological behavior<sup>23</sup>. One can think of the lava lamp as an example of a novelty item that shows strange fluid properties in an artful and pleasing way. Other fluids related toys are soap

bubble generators, smoke ring and air vortex generators (known as blasters), balsa wood or paper model airplanes, rockets, and balloon helicopters among others. It is interesting to note that Ludwig Prandtl, a giant figure in Fluid Mechanics, was fascinated by toys as observed by Theodore von Karman, one of his most famous students<sup>24</sup>. The late Professor Julius Sumner Miller found toys “enchanting.” He hosted many TV shows on physics demonstrations with simple devices and toys in the 1960s and 70s. Video clips of several of his shows are available on YouTube<sup>25</sup>.

The purpose of this paper is to introduce three fluids toys that, although available for quite sometime, have not been documented in the literature. Indeed the author was surprised that his search did not result in any relevant references, as he had assumed for sure someone had seen the educational value of these toys and had written about them. Thus, he decided to write this paper to share his findings about these toys and their potential in education.

### Fluids Toys

Three inexpensive novelty toys that display an array of fluid mechanics phenomena are shown in Figure 1. They cost \$7 to \$11 each, and are available through online stores specializing with science and educational kits and at science museum gift shops<sup>26</sup>. The common tread among these toys is that the fluid motions they display are driven by density difference between the fluids (or other substance) contained in them. The toys could be used in a variety of educational settings, including class demonstrations to enhance lectures and student understanding, design projects in independent studies or undergraduate research, and informal science education for general public and younger students through school visitation programs. Later in the paper, several homework assignments based on these toys are also suggested as challenges for students.

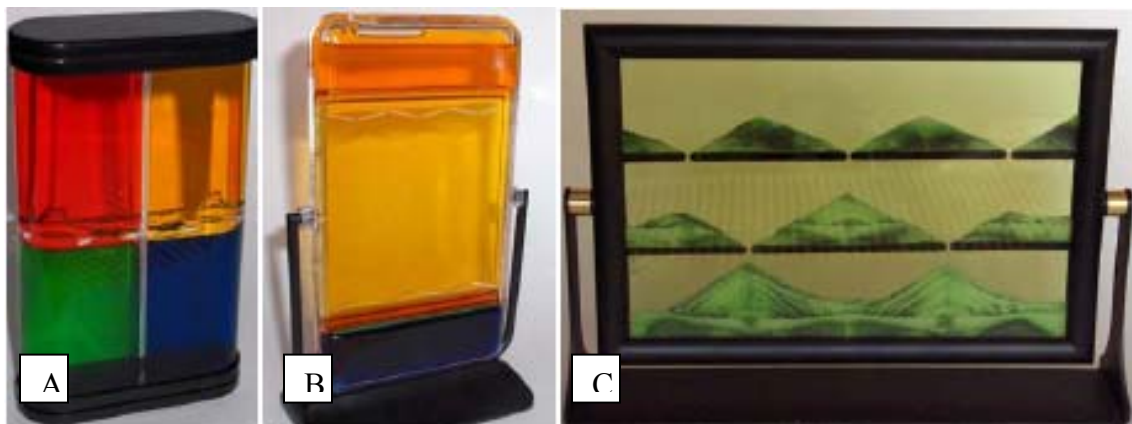


Figure 1 – Density differential fluids toys - (A) colors in motion toy # 1 (1 x 3 x 5 inches), (B) colors in motion toy # 2 (7/8 x 4 x 7 inches), (C) sand painting (1/2 x 5 x 7 inches). These toys are trademark by Westminster, Inc. Atlanta, GA.

Colors in Motion Toy # 1 - This simple toy as shown in Figure 1A contains colored liquids in four chambers. If observed carefully, one can see and enjoy a variety of fluid

mechanics phenomena displayed by this toy when operated. Each of the phenomena displayed namely drop formation, stream buckling, drop coalescence, etc., has been the subject of contemporary scientific and engineering investigations. The toy is made of a clear plastic box divided into four equal chambers. The left chambers are separated from the right. On each side though, the top and bottom chambers are connected to each other with two funnel-shaped openings, one downward and one upward, to allow exchange of liquids between them. Nearly equal amounts of two immiscible liquids with different densities fill the chambers on each side of the box. The liquid in each chamber is dyed with a different color, hence giving the impression that four different liquids fill the chambers. There is also a small volume of air. The liquids and the walls are non-wetting<sup>27</sup>. Using this toy is simple; invert the box and enjoy the motion created as heavier liquid flows down while the lighter liquid flows up. Although this does seem simple and straight forward there are at least three fascinating details that one can observe. These are described next.

Figure 2 presents snap shots at different times after the box is inverted. (The box was undisturbed for a while prior to the inversion as to ensure the liquids in each chamber were homogenous and without droplets and bubbles.) Upon inversion three distinct flow situations can be observed. First, the air quickly rises from the bottom to the top chambers with rapid succession of air bubbles, accompanied by sound, causing rapid transfer of heavier liquid in droplets from the top to the bottom chambers for about 5-6 seconds (Figure 2A). Second, after all air has risen to the top, the liquids start replacing each other via slowly and steady drop formations, heavier drops falling and lighter drops rising (Figures 2B and 2C). Each drop is encased by a film of the other liquid through which it flows. As drops settle on their like liquid surfaces, they float for a while and then coalesce. This portion of the flow takes about 4.5 minutes. Third, the downward flows of drops change into streams when, before detachment from the opening, they touch their like liquid surface below (Figure 2D). Closer observation reveals buckling of the stream as it experiences a compressive force from below. This portion of the flow lasts several seconds after which the funnel-shaped openings are covered by the other liquid. The liquid exchange continues until all liquids have completely filled their respective chambers. The entire sequence of motion takes a little over 5 minutes. Now the box is ready to be inverted again and the above sequence repeated (Figure 2E).

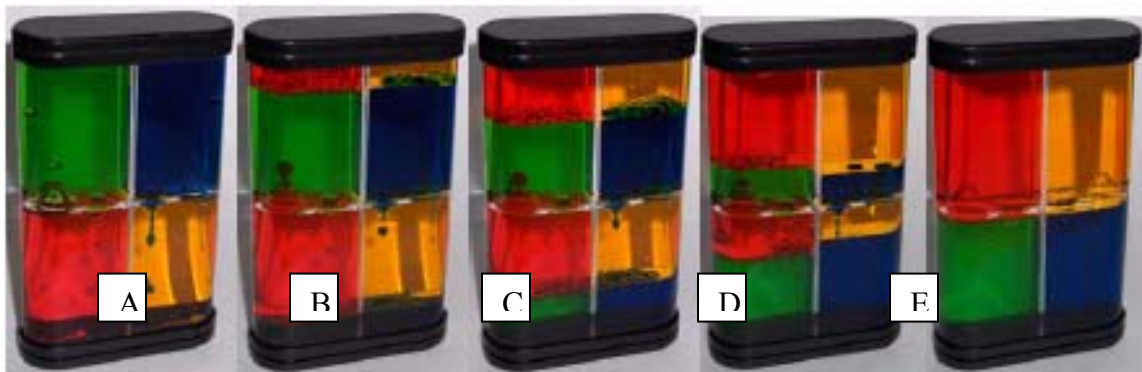


Figure 2 – Snap shots of colors in motion toy # 1.

While the above description dealt with the normal operation of the toy, other interesting situations can be created and observed. These could be assigned as challenges to students who have seen the normal demonstration of the toy. Two examples are presented later in the paper but there are more possibilities.

Several modified versions of this toy have also appeared in the market; four samples can be seen in Figure 3. Some incorporate wheels that turn as drops fall on them and some have rails that guide falling drops. Another recent modification is an arrangement of rows of staggered obstacles through which drops have to pass. Watching deformation of drops as they navigate the obstacles is fascinating. In all these toys the primary concept is to have fluids of different densities that are immiscible and non-wetting.



Figure 3 – Samples of density driven fluids toys.

Colors in Motion Toy # 2 – This is a simple toy that creates beautiful overlapping patterns of colored liquids as they flow down through two narrow gaps between vertical plates. The toy can be considered a modified Hele-Shaw (HS) cell. The HS cell, basically made of two plates separated by a small gap ( $\leq 1$  millimeter) is a well known device that has been used by researchers to investigate two dimensional flows<sup>28</sup>. The toy comprises of two HS cells side by side with a common wall. The top and bottom ends (about 1 inch in length) are widened to allow for holding adequate amounts of liquids. In each cell, there are two immiscible liquids with different densities. When the toy is oriented vertically, the heavier liquid just fills the lower reservoir and the rest of the cell is filled with the lighter liquid as shown in Figure 1B. The lighter fluids are the same in both cells and are dyed with yellow color. The heavier fluids are dyed with red and green colors. Small volume of air is present in each cell (in its top reservoir). At both ends of the narrow section in each cell, a series of thin plastic strips are positioned in a zigzag pattern with small gaps ( $\sim 1$  mm) through which liquids flow as they exchange their spaces. The toy comes with a swivel-frame and a base.

To use the toy, it is simply turned 180 degrees about its pivot and the ensuing flow is observed. Similar to the previously described toy, this one also has simple operation but displays a variety of intriguing fluid mechanics situations. First, upon turning the toy, a

small amount of froth that had been collected on the heavier liquid surfaces rise to the top, and air bubbles quickly move from the now lower reservoirs to the top reservoirs, see Figure 4A. As the former takes place, mushroom-like plumes are created. The above takes only a few seconds while the heavier liquids (red and green) flow downward through the openings. As shown in Figure 4B, the drops in the narrow gaps are squeezed into flat blobs of liquid. Notice the overlap of the red and green blobs, which resembles a third color, violet in the photos. Some blobs tend to break into two or more pieces and are deformed into new shapes as they flow down. The lighter fluid has to find a path through the heavier liquid to flow up to replace it. The up flow, indicated as streaks in Figure 4B and C, takes place mostly through the openings situated at the peaks of the zigzag strips. The patterns created by the blobs are never the same during the one minute operation. Near the end, packets of froth start to flow down, but at a much slower pace compared to the liquid blobs and with their own physical characteristics, see Figure 4D. Elongated pieces of froth sometimes divide into two parts and the elastic rebound is quite noticeable. Those froth pieces that have a larger liquid fraction flow down faster, sometimes bumping into and merging with the ones down below. The froth dynamics is ever changing especially when the pieces of froth find their way through the openings into the lower reservoirs. Figure 5 captures several interesting instants of the froth life!

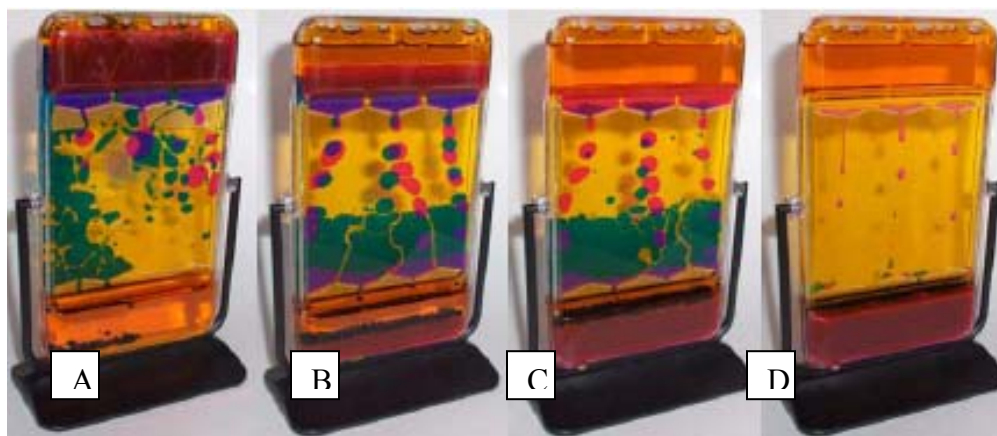


Figure 4 – Snap shots of colors in motion toy # 2.

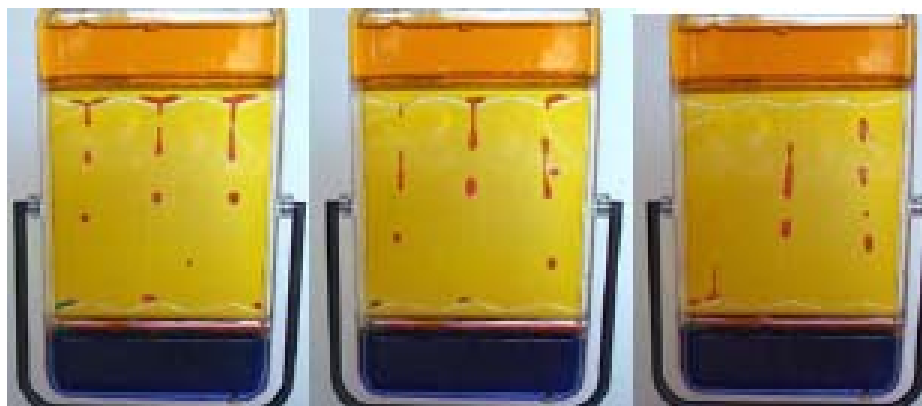


Figure 5 – Dynamics of froth life displaying stretching, break off, and bumping.

**Sand Painting Toy** – This novelty toy is also a modified HS cell, two glass plates with a very small gap (less than a millimeter) containing colored fine sand (black and green) and sand dust. The sand roughly fills one third of the space in the toy with the rest filled by air. Small amount of tiny reflective confetti added to the sand enhances the visual appearance of the toy. The cell is divided into three equal horizontal sections with narrow strips of dividers, with two or three small openings between each pair of adjacent sections as shown in Figure 6A. The toy can rotate along its horizontal axis in a frame with a base. Again, the instruction is simple: rotate the toy by one half a turn and observe the sand flow, and even air flow, which at the end create a beautiful sandscape or a painting with sand! Once the unit is turned, the sand flows down and the air has to flow up to replace the space vacated by the sand, see Figure 6B. Sometimes the up flow is clearly visible through one of the openings, where there is no down flow. But most of the times down flow and up flow take place alternatively through the same opening, and this requires careful observation. As sand flows down from one section to the one below it, mountains are formed underneath each opening as shown in Figure 6C. The mountains so formed clearly exhibit angle of repose – the angle created as granulates fall freely, a common situation observed in transport of granular materials. It takes about 6 minutes for the motion of sand particles to come to rest, and then the toy is ready for another half a turn to start a new sand painting, see Figure 6D.

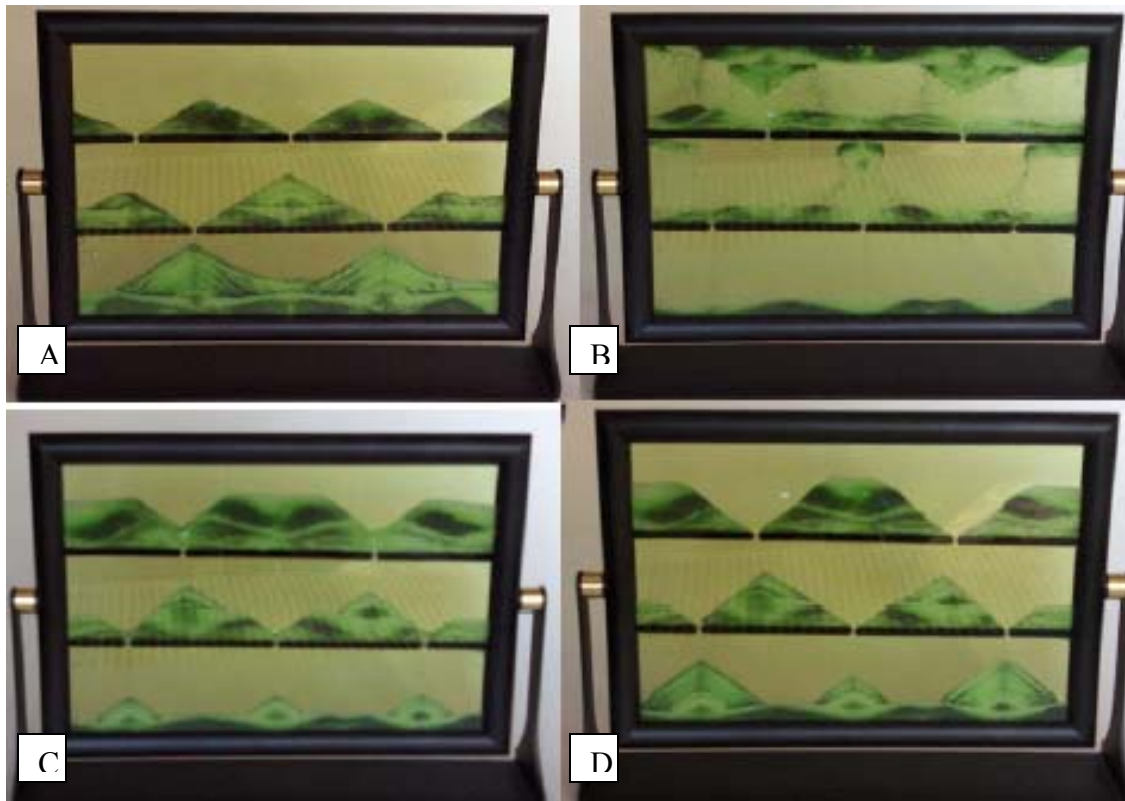


Figure 6 – (A) The instant before toy was inverted; (B and C) snap shots as sand falls down and air flows up; (D) the sand painting at the end.

## Activities with Toys

The toys described above can be used to enhance lectures, and to motivate students to make observations of simple things around them, which quite often can be educational. To encourage students to practice and boost their observational skill, four assignments are provided here as student challenges. Interested readers can find out answers to these challenges by contacting the author.

Challenge # 1. Create the flow situation shown in Figure 7A, where a volcanic like eruption is taking place. This is in contrast with the steady and slow upward moving drops observed during the normal operation.

Challenge # 2. Create the situation shown in Figure 7B, where the liquid levels are different on the two sides, as opposed to the same level during the normal operation.

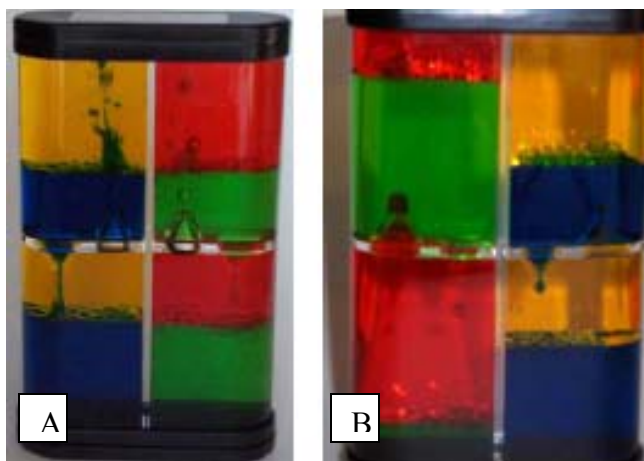


Figure 7 – (A) Volcano like eruption takes place in the upper chambers. (B) Light-heavy liquids' interfaces are different on the two sides.

Challenge # 3. This relates to color in motion toy # 2. Create the situation shown in Figure 8, where the heavier liquids are divided between the reservoirs at the two ends of the cells but almost absent in the narrow gap region between the reservoirs.



Figure 8 – Challenge # 3. Heavier liquids at the two ends with little in the middle.

Challenge # 4. Create a situation similar to the one shown in Figure 9, where a sand painting is skewed to the right. This is markedly different than that obtained during the normal operation (shown in Figure 6).

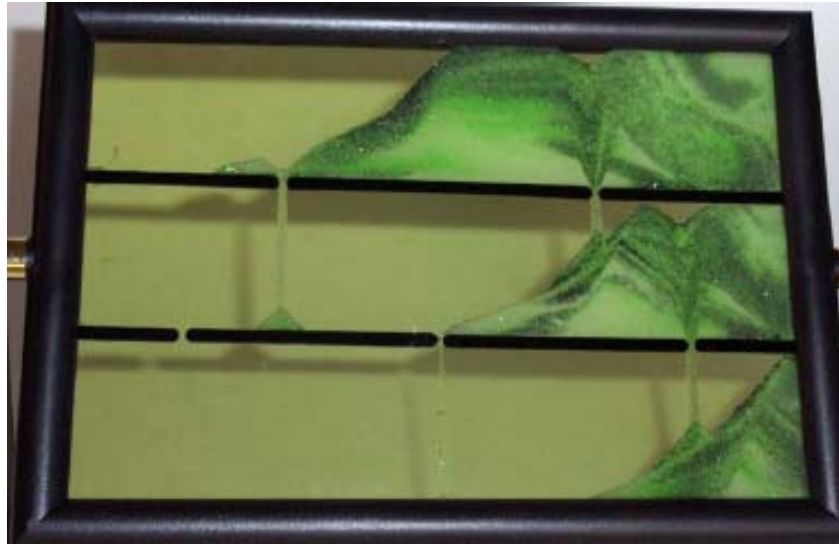


Figure 9 – Challenge # 4. Skewed sand painting.

The following ideas can be assigned as projects to students in design and other classes.

Project # 1. Based on the second toy, design an apparatus to investigate scientific questions such as: what will happen if two immiscible liquids with different densities (e.g., oil and vinegar) are in a HS cell separated by a partition with only one opening? How does the opening size affect the flow?

Project # 2. Design and construct larger scale of the second or third toy or modifications of them as engineering art objects for displays in the hallways of engineering buildings. Adding iron shavings to the sand and incorporating electromagnets controlled by the user in the sand painting device can add element of interactivity to the final product!

Project # 3. Design educational toys as part of various course projects to demonstrate a scientific principle. For example, use magnets to show forces; vacuum cleaner as a source of air flow to show drag and lift on objects; and impacting balls of different materials to show coefficient of restitution. A good starting point for toy design and construction can be found at *sciencetoymaker.org*. An example of a toy, “variable pitch drum,” designed as part of assignments in an engineering course can be seen in reference<sup>29</sup>.

Furthermore, the toys can be used in educating public about aspects of science that could be well considered artistic at events such as Engineering Week, university open houses, etc. They can also be shown to younger students in K-12 grades to excite and motivate them for considering carrier paths in science and engineering.



The ultimate goal of using educational toys is to promote student learning as well as to increase public awareness of and appreciation for science and engineering.

## Conclusion

Properly selected toys continue to be used in teaching to illustrate physical concepts in order to enhance students learning. Three simple and inexpensive toys that exhibit an amazing array of fluid mechanics phenomenon were introduced and described in the paper. These educational toys could be used to spice up student learning and to excite general public about beauty of science. Several assignments for students were presented that encourage development/enhancement of keen observational skill. As quoted by Ascher Shapiro in the preface to the book on fluids films<sup>30</sup>, “fluid mechanics is a photogenic subject,” and as such these fluid mechanics toys would most probably be of interest to general public as well as students of science and engineering.

## Acknowledgement

This paper is dedicated to Paul G. Hewitt, the physicist-cartoonist whose playful presentation of physics, especially in his text book *Conceptual Physics*, has been a source of inspiration for the author. Funding from the Committee on Academic Planning and Development at the University of the Pacific is greatly appreciated which allowed purchasing the toys described here and several others. The author thanks Dr. Ed Pejack for providing helpful comments on the manuscript including the idea presented in project# 3.

## References

1. Freier, G., “The Use of Demonstrations in Physics Teaching,” *The Physics Teacher*, pp. 384-386, 1981
2. Pinkston, E. R., “The Use of Demonstrations in Teaching Introductory Physics,” *The Physics Teacher*, pp. 387-388, 1981
3. Hilton, W. A., “Demonstrations as an Aid in the Teaching of Physics,” *The Physics Teacher*, pp. 389-390, 1981
4. Gross, J. L., “Seeing Is Believing: Classroom Demonstrations as Scientific Inquiry,” *Journal of Physics Teacher Education Online*, Vol. 1, No. 3, pp. 3-6, 2002
5. Estes, A., “Shock and Awe in the Civil Engineering Classroom,” *Journal of Professional Issues in Engineering Education and Practice*, pp. 1-5, January 2005
6. Schaaf, R. V. and Klosky, J. L., “Classroom Demonstrations in Introductory Mechanics,” *Journal of Professional Issues in Engineering Education and Practice*, pp. 83-89, April 2005
7. Murline, A., “Toys That Teach,” *ASEE Prism Online*, Vol. 13, No. 3, 2004
8. Levinstein, H., “The Physics of Toys,” *The Physics Teacher*, pp. 358-365, September 1982

9. Turner, R. C., "Toys in Physics Teaching: Balancing Man," *American Journal of Physics*, Vol. 55, No. 1, pp. 84-85, 1987
10. Turner, R., "100 Years of Physics and Toys: Balancing Toys," *The Physics Teacher*, Vol. 30, pp. 542-543
11. Aref, H., Hutzler, S., and Weaire, D., "Toying with Physics," *Euro Physics News*, Vol. 38, No. 3, pp. 23-26, 2007
12. Guemez, J., Fiolhais, C. and Fiolhais, M., "Toys in Physics Lectures and Demonstrations – A Brief Review," *Physics Education*, Vol. 44, No. 1, pp. 53-64, 2009
13. Turner, R. C., "Toys in Physics Teaching: Cartesian Diver," *American Journal of Physics*, Vol. 51, No. 5, pp. 475-476, 1983
14. Connolly, W., "An Automated Cartesian Diver Apparatus," *The Physics Teacher*, p. 51, January 1989
15. Graham, R. M., "An Extremely Sensitive Cartesian Diver," *The Physics Teacher*, Vol. 32, No. 3, pp. 182-183, 1994
16. Guemez, J., Fiolhais, C. and Fiolhais, M., "A Demonstration Apparatus for the Cartesian Diver," *The Physics Teacher*, Vol. 41, No. 8, pp. 495-496, 2003
17. Amir, N. and Subramaniam, R., "Making a Fun Cartesian Diver: A Simple Project to Engage Kinaesthetic Learners," *Physics Education*, Vol. 42, No. 5, pp. 478-480, 2007
18. Guemez, J., Valiente, R., Fiolhais, C., and Fiolhais, M., "Experiments with the Drinking Bird," *American Journal of Physics*, Vol. 71, No. 12, pp. 1257-1263, 2003
19. Lorenz, R., "Finite Time Thermodynamics of an Instrumented Drinking Bird Toy," *American Journal of Physics*, Vol. 74, No. 8, pp. 677-682, 2006
20. Miller, J. S., "Physics in a Toy Boat," *American Journal of Physics*, Letters to the Editor, Vol. 26, p. 199, 1958
21. Mackay, R. S., "Boat Driven by Thermal Oscillations," *American Journal of Physics*, Vol. 26, pp. 583-584, 1958
22. Finnie, I. and Curl, R. L., "Physics in a Toy Boat," *American Journal of Physics*, Vol. 31, pp. 289-293, 1963
23. Sarquis, A. M., "Dramatization of Polymeric Bonding Using Slime," *Journal of Chemical Education*, Vol. 63, No. 1, pp. 60-61, 1986
24. von Karman, T. and Edson, L., The Wind and Beyond, Little and Brown, Boston, pp. 37-38, 1967
25. Julius Sumner Miller video on mechanical toys  
<http://www.youtube.com/watch?v=LZ5HpHWIDS8&feature=related>
26. <http://www.teachersource.com>, <http://scientificsonline.com>, <http://www.officeplay.com>,  
[www.focustoys.com](http://www.focustoys.com)
27. Courbin, L. and Stone, H. A., "Your Wetting Day," *Physics Today*, pp. 84-85, February 2007
28. Granger, R. A. (Editor), Experiments in Fluid Mechanics, Holt, Rinehart and Winston, New York, pp. 416-427, 1988

29. Demonstration of a variable pitch toy drum designed for an engineering course,  
<http://www.youtube.com/watch?v=KImDGtlo-8&feature=related>
30. Shapiro, A., Illustrated Experiments in Fluid Mechanics – The NCFMF Book of Film Notes, The MIT Press, Cambridge, MA, p. xiii, 1972

### **Biographical Sketch**

Said Shakerin is a professor of mechanical engineering at the University of the Pacific in Stockton, California, where he has been since 1986. He is a registered professional engineer in California, and he was educated at Arya-Mehr (now Sharif) University of Technology in Iran, Portland State, Oregon State, and Colorado State Universities in the USA. He served as department chairman in 1995-1998 but stepped down due to medical condition. His interests include development of teaching tools to enhance students learning and design of water fountains with special effects.

## **Comparison of BOK1 and BOK2 to NAU's Undergraduate Civil Engineering Program**

Debra Larson, College of Engineering, Forestry & Natural Sciences,  
Northern Arizona University

### **Introduction**

The American Society of Civil Engineering is promoting change to the path for entering the professional practice of civil engineering. This change is articulated in Policy 465<sup>1</sup>, which supports the attainment of a Body of Knowledge (BOK) by way of a fulfillment pathway: bachelor's degree plus a master's degree or thirty semester credits plus experience. This paper presents a review of the two versions of the BOK, BOK1 and BOK2, and a comparison of these versions to the undergraduate civil engineering curriculum at Northern Arizona University (NAU), which is benchmarked to the 2007-2008 ABET Criteria for Accrediting Engineering Programs<sup>2</sup>.

### **BOK1**

In January of 2004, the ASCE published the BOK<sup>3</sup> (known as the BOK1) that identified fifteen learning outcomes, of which the first eleven came directly from Criterion 3 of the ABET Criteria for Accrediting Engineering Programs, herein referred to simply as the ABET Criteria. The additional four outcomes addressed technical specialization, project management, construction, asset management, business and public policy and administration, and leadership and its attending attitudes.

In late 2005, an ASCE subcommittee, named the Levels of Achievement subcommittee, produced a report<sup>4</sup> that rewrote the fifteen BOK1 outcomes and framed them within Bloom's cognitive taxonomy. The subcommittee's work represented a major advancement to body of knowledge concept. The fifteen outcomes were restated in terms of action-orientated, measurable verbs and included additional specificity. In example, the broadly stated communication outcome, ABET Outcome (g), was restated to specify communication as covering verbal, written and graphical techniques. Achievement levels per outcome per stages of the fulfillment pathway were made explicit. In example, Outcome 12 - specialized area of civil engineering knowledge – was assigned solely to the master's/30 credits level of the fulfillment pathway. Recently, Outcomes 13 - 15 of the revised BOK1 have been incorporated into the 2008-2009 ABET Criteria<sup>5</sup> within Criterion 9 for civil engineering programs. Specifically, graduates must be able to “explain basic concepts in management, business, public policy, and leadership.” In addition, the previous “proficiency” language relating to the four recognized major areas of civil engineering was softened so that programs need only to demonstrate

graduates' abilities to "apply knowledge" in four technical areas appropriate to civil engineering. ASCE adopted the subcommittee's revised BOK1 as the standing BOK1, and it is this version that is used in this paper. The revised BOK1 outcomes for the bachelor's stage of the fulfillment pathway, along with the corresponding level of achievement at graduation and the corresponding ABET Criterion 3 outcome, are provided in Table 1.

**Table 1. ASCE's BOK1 Outcomes**

<b>BOK1 Outcomes at the Baccalaureate</b>	<b>Achieve. Level</b>	<b>ABET Criteria 3</b>
1. Graduates can solve problems in mathematics through differential equations, calculus-based physics, chemistry, and one additional area of science.	3: Application	(a)
2. Graduates can design a civil engineering experiment to meet a need; conduct the experiment, and analyze and interpret the resulting data.	5: Synthesis	(b)
3. Graduates can design a complex system or process to meet desired needs, within realistic constraints such as economic, environmental, social, political, ethical, health and safety, manufacturability, and sustainability.	5: Synthesis	(c)
4. Graduates can function effectively as a member of a multidisciplinary team.	3: Application	(d)
5. Graduates can solve well defined engineering problems in four technical areas appropriate to civil engineering.	3: Application	(e)
6. Graduates can analyze a complex situation involving multiple conflicting professional and ethical interests, to determine an appropriate course of action.	4: Analysis	(f)
7. Graduates can organize and deliver effective verbal, written, and graphical communications.	4: Analysis	(g)
8. Drawing upon a broad education, graduates can determine the global, economic, environmental, and societal impacts of a specific, relatively constrained engineering solution.	4: Analysis	(h)
9. Graduates can demonstrate the ability to learn on their own, without the aid of formal instruction.	3: Application	(i)
10. Graduates can incorporate specific contemporary issues into the identification, formulation, and solution of a specific engineering problem.	3: Application	(j)
11. Graduates can apply relevant techniques, skills, and modern engineering tools to solve a simple problem.	3: Application	(k)
12. Specialized area	Not applicable	
13. Graduates can explain key concepts and problem-solving processes used in management.	2: Comprehend	
14. Graduates can explain key concepts and problem-solving processes used in business, public policy, and public administration.	2: Comprehend	
15. Graduates can explain the role of the leader, leadership principles, and attitudes conducive to effective professional practice of civil engineering.	2: Comprehend	

## **BOK2**

Not stopping there, however, ASCE continued in its efforts to further refine the BOK; motivated by questions and suggestions from stakeholders and an interest to further align the BOK with the

newly released 2006 ASCE Vision for Civil Engineering<sup>6</sup>. This work has resulted in the in the BOK2<sup>7</sup> published in 2008. The BOK2 consists of twenty-four outcomes with respective levels of achievement for each stage of the fulfillment pathway from the bachelor's degree through experience. Every outcome, including technical specialization, is targeted for some level of achievement at the bachelor's stage; making this the primary strategy of the fulfillment pathway. Three of the twenty-four BOK2 outcomes are mapped to the master's level. Unlike the BOK1, the BOK2 outcomes do not directly lineup to the eleven ABET Criterion 3 outcomes. ASCE, however, has related, in a general way, nineteen of the twenty-four BOK2 outcomes to Criterion 3, 5, or 9 of the ABET Criteria.

Many of the BOK2 outcomes were developed through disaggregation and specificity of an originating BOK1 outcome or an ABET Criteria requirement. Consider two examples. The BOK1 technical core Outcome 1, which is related to ABET's Outcome (a), is presented as four separated outcomes in the BOK2: two - the mathematics and natural sciences outcomes - are directly identifiable subsets of the BOK1 language, and two – materials science and mechanics outcomes – are newly developed to add specificity to the word “engineering” as it occurs in Outcome (a). The ABET Criterion 5 requirement of a complementary general education component has been addressed by BOK2 by two outcomes specifically applying the humanities and social sciences to professional practice. Relative to the BOK1, other outcomes came into being because the committee added them anew (e.g. historical perspectives, risk and uncertainty) or they were elevated to stand-alone status from their previous standing as being part of a list from which a program could chose to address (e.g. sustainability, globalization). In total, the BOK2 presents an increase of seven new outcomes over the earlier BOK1.

The BOK2 outcomes for the bachelor's stage of the fulfillment pathway, along with the corresponding level of achievement at graduation and the related BOK1 outcomes, are provided in Table 2. The related BOK1 analysis of this table is slightly different than the analysis provided in the BOK2 report<sup>7</sup> of Table H-2. The specific differences lie with BOK2 Outcomes 12 and 14. This author suggests that BOK2 Outcome 12 **is not** related to BOK1 Outcome 3 on design as the topics of risk and uncertainty do not appear in the Outcome 3 language. In contrast, this author suggests that BOK2 Outcome 17 **is** related to BOK1 Outcome 14.

### **Comparison to NAU**

In this section, the civil engineering undergraduate program of NAU, which is currently benchmarked to the 2007-2008 ABET Criteria for Accrediting Engineering Programs<sup>2</sup>, is compared against both the BOK1 and BOK2. Members of the department faculty were formed into teams of two to estimate the level of achievement of recent graduates in comparison to the BOK1 and BOK2. The results of the four faculty teams were averaged and rounded to the nearest whole number ranging from a low of 1, which corresponds to Bloom's Knowledge

category, to a high of 6, which corresponds to Bloom's Evaluation category. The rounded mean result was then compared to the ASCE target level of achievement (indicated as LOA in the following tables) at the baccalaureate level. Mean to target results of 1.0 indicate that the NAU evaluation and BOK LOA were the same. These comparative results are presented as Tables 3 and 4.

**Table 2. ASCE's BOK2 Outcomes**

<b>BOK2 Outcomes at the Baccalaureate</b>	<b>Achiev. Level</b>	<b>BOK1</b>
1. Solve problems in mathematics through differential equations and apply this knowledge to the solution of engineering problems.	3: Application	1
2. Solve problems in calculus-based physics, chemistry, and one additional area of natural science and apply this knowledge to the solution of engineering problems.	3: Application	1
3. Demonstrate the importance of the humanities in the professional practice of engineering.	3: Application	
4. Demonstrate the incorporation of social sciences knowledge into the professional practice of engineering.	3: Application	
5. Use knowledge of materials science to solve problems appropriate to civil engineering.	3: Application	1
6. Solve problems in solid and fluid mechanics.	4: Analysis	1
7. Analyze the results of experiments and evaluate the accuracy of the results within the known boundaries of the tests and materials in or across more than one of the technical areas of civil engineering.	4: Analysis	2
8. Develop problem statements and solve well-defined fundamental civil engineering problems by applying appropriate techniques and tools.	3: Application	5
9. Design a system or process to meet desired needs within such realistic constraints as economic, environmental, social, political, ethical, health and safety, constructability, and sustainability.	5: Synthesis	3
10. Apply the principles of sustainability to the design of traditional and emergent engineering systems.	3: Application	3
11. Drawing upon a broad education, explain the impact of historical and contemporary issues on the identification, formulation, and solution of engineering problems and explain the impact of engineering solutions on the economy, environment, political landscape, and society.	3: Application	8 & 10
12. Apply the principles of probability and statistics to solve problems containing uncertainties.	3: Application	
13. Develop solutions to well-defined project management problems.	3: Application	13
14. Solve problems in or across at least four technical areas appropriate to civil engineering.	4: Analysis	
15. Define key aspects of advanced technical specialization appropriate to civil engineering.	1: Knowledge	12
16. Organize and deliver effective verbal, written, virtual, and graphical communications.	4: Analysis	7
17. Discuss and explain key concepts and processes involved in public policy.	2: Comprehend	14
18. Explain key concepts and processes used in business and public administration.	2: Comprehend	14
19. Organize, formulate, and solve engineering problems within a global context.	3: Application	10

20. Apply leadership principles to direct the efforts of a small, homogenous group.	3: Application	15
21. Function effectively as a member of an intra-disciplinary team.	3: Application	4
22. Explain attitudes supportive of the professional practice of civil engineering.	2: Comprehend	15
23. Demonstrate the ability for self-directed learning.	3: Application	9
24. Analyze a situation involving multiple conflicting professional and ethical interests to determine an appropriate course of action.	4: Analysis	6

**Table 3. Estimating NAU BS Graduates' Level of Achievement to BOK1**

	<b>BOK1 Outcome at Baccalaureate Level</b>	<b>BOK 1 LOA</b>	<b>NAU Rounded Mean</b>	<b>Mean- to- LOA</b>
1	Solve problems in mathematics through differential equations, calculus-based physics, chemistry, and one additional area of science.	3	3	1.0
2	Design a civil engineering experiment to meet a need; conduct the experiment, and analyze and interpret the resulting data.	5	4	0.8
3	Design a complex system or process to meet desired needs, within realistic constraints such as economic, environmental, social, political, ethical, health and safety, manufacturability, and sustainability.	5	5	1.0
4	Function effectively as a member of a multi-disciplinary team	3	4	1.3
5	Solve well-defined engineering problems in four technical areas appropriate to civil engineering.	3	3	1.0
6	Analyze a complex situation involving multiple conflicting professional and ethical interests, to determine an appropriate course of action.	4	3	0.8
7	Organize and deliver effective verbal, written, and graphical communications.	4	4	1.0
8	Determine the global, economic, environmental, and societal impacts of a specific, relatively constrained engineering solution.	3	2	0.7
9	Demonstrate the ability to learn on their own, without the aid of formal instruction.	3	4	1.3
10	Incorporate specific contemporary issues into the identification, formulation, and solution of a specific engineering problem.	3	3	1.0
11	Apply relevant techniques, skills, and modern engineering tools to solve a simple problem.	3	4	1.3
12		NA	4	NA
13	Explain key concepts and problem-solving processes used in management.	2	2	1.0
14	Explain key concepts and problem-solving processes used in business, public policy, and public administration.	2	1	0.5
15	Explain the role of the leader, leadership principles, and attitudes conducive to effective professional practice of civil engineering.	2	2	1.0

The BOK1 analysis of Table 3 suggested that the NAU curriculum of 130 semester units and the corresponding educational environment prepares its students to meet or exceed the expected levels of achievement for ten of the fourteen applicable BOK1 outcomes. For three cases -



BOK1 Outcomes 4, 9, and 11 - the NAU evaluation exceeded the LOA by one level. Of the four below-target outcomes, one was unique to BOK1 and not a part of ABET prior to 2008-2009. The well-defined levels of achievement specified by the BOK1 for the other three below-target outcomes required a higher level of intellectual performance than that required by the corresponding ABET outcomes.

These NAU results are consistent to the results of an ASCE committee – Curriculum Committee of the Committee on Academic Prerequisites for Professional Practice – representing twenty institutions charged to determine the status of civil engineering education in relation to the BOK1. In their 2006 report<sup>8</sup>, the committee concluded that none of the twenty programs addressed all of the BOK1 outcomes to the level of achievement expected.

**Table 4. Estimating NAU BS Graduates' Level of Achievement to BOK2**

	<b>BOK2 Outcome at Baccalaureate Level</b>	<b>BOK 2 LOA</b>	<b>NAU Rounded Mean</b>	<b>Mean- to- LOA</b>
1	Solve problems in mathematics through differential equations and apply this knowledge to the solution of engineering problems.	3	3	1.0
2	Solve problems in calculus-based physics, chemistry, and one additional area of natural science and apply this knowledge to the solution of engineering problems.	3	3	1.0
3	Demonstrate the importance of the humanities in the professional practice of engineering.	3	2	0.7
4	Demonstrate the incorporation of social sciences knowledge into the professional practice of engineering	3	2	0.7
5	Use knowledge of materials science to solve problems appropriate to civil engineering.	3	2	1.0
6	Analyze and solve problems in solid and fluid mechanics.	4	4	1.0
7	Analyze the results of experiments and evaluate the accuracy of the results within the known boundaries of the tests and materials in or across more than one of the technical areas of civil engineering.	4	4	1.0
8	Develop problem statements and solve well-defined fundamental civil engineering problems by applying appropriate techniques and tools.	3	3	1.0
9	Design a system or process to meet desired needs within such realistic constraints as economic, environmental, social, political, ethical, health and safety, constructability, and sustainability.	5	5	1.0
10	Apply the principles of sustainability to the design of traditional and emergent engineering systems.	3	1	0.3
11	Drawing upon a broad education, explain the impact of historical and contemporary issues on the identification, formulation, and solution of engineering problems and explain the impact of engineering solutions on the economy, environment, political landscape, and society.	3	2	0.7
12	Apply the principles of probability and statistics to solve problems containing uncertainties.	3	1	0.3

13	Develop solutions to well-defined project management problems.	3	2	0.7
14	Analyze and solve well-defined engineering problems in at least four technical areas appropriate to civil engineering.	4	4	1.0
15	Define key aspects of advanced technical specialization appropriate to civil engineering.	1	3	3.0
16	Organize and deliver effective verbal, written, virtual, and graphical communications.	4	4	1.0
17	Discuss and explain key concepts and processes involved in public policy.	2	1	0.5
18	Explain key concepts and processes used in business and public administration.	2	1	0.5
19	Organize, formulate, and solve engineering problems within a global context.	3	1	0.3
20	Apply leadership principles to direct the efforts of a small, homogenous group.	3	3	1.0
21	Function effectively as a member of an intradisciplinary team.	3	3	1.0
22	Explain attitudes supportive of the professional practice of civil engineering.	2	2	1.0
23	Demonstrate the ability for self-directed learning.	3	3	1.0
24	Analyze a situation involving multiple conflicting professional and ethical interests to determine an appropriate course of action.	4	3	0.8

In contrast, the same curriculum and educational environment prepares the NAU civil engineer to meet or exceed the expected levels of achievement for fourteen of the twenty-four applicable BOK2 outcomes. Eight (BOK2 Outcomes 3, 4, 10, 11, 13, 17, 18, and 19) of the ten below-target results are for outcomes unique to BOK2 and not a part of the 2007-2008 ABET Criteria. The remaining two below-target outcomes (BOK2 Outcomes 12 and 24) are for outcomes with a level of achievement higher than the corresponding expectations of 2007-2008 ABET Criteria.

These NAU results are consistent to the soon to be published results<sup>9</sup> of an ASCE committee – BOK Educational Fulfillment Committee – representing ten institutions charged to investigate and document how programs are incorporating and/or can incorporate the BOK2. A synthesis of each institution’s analysis of their graduates’ performance relative to the BOK2 revealed that eleven of the twenty-four outcomes are believed to not be currently met at the expected level of achievement by four or more institutions.

## Conclusions

The Department of Civil and Environmental Engineering at NAU is currently investigating ways to better align its curricula and environment to the BOK1. The motivation primarily comes from ABET, whereby three of the four new outcomes are now a part of Criterion 9. The department believes that its current program with strengths in design, multi-disciplinary teaming, life-long learning, modern engineering tools, and leadership can be modified with some modest effort to

completely meet BOK1. On the other hand, meeting the BOK2 that contains seven new outcomes in comparison to the BOK1 will be a challenge for NAU's already overly-constrained, unit-limited undergraduate program.

## References

1. ASCE Committee on Academic Prerequisites for Professional Programs. 2008. Key Points About Policy Statement 465 Academic prerequisites for Licensure & Professional Practice, Reston, VA, April. (<http://www.asce.org/raisethebar>).
2. ABET. 2007. Criteria for Accrediting Engineering Programs: Effective for Evaluations During the 2007-2008 Accreditation Cycle, ABET, Inc., Baltimore, MD. (<http://www.abet.org>).
3. ASCE Body of Knowledge Committee. 2004. Civil Engineering Body of Knowledge for the 21<sup>st</sup> Century: Preparing the Civil Engineering for the Future, Reston, VA, January. (<http://www.asce.org/raisethebar>).
4. ASCE Levels of Achievement Subcommittee. 2005. Levels of Achievement Applicable to the Body of Knowledge Required for Entry Into the Practice of Civil Engineering at the Professional Level, Reston VA, September. (<http://www.asce.org/raisethebar>)
5. ABET. 2008. Criteria for Accrediting Engineering Programs: Effective for Evaluations During the 2008-2009 Accreditation Cycle, ABET, Inc., Baltimore, MD. (<http://www.abet.org>).
6. ASCE Task Committee to Plan a Summit on the Future of the Civil Engineering profession. 2007. The Vision for Civil Engineering in 2025, Reston, VA. (<http://www.asce.org/Vision2025.pdf>)
7. ASCE Body of Knowledge Committee. 2008. Civil Engineering Body of Knowledge for the 21<sup>st</sup> Century: Preparing the Civil Engineer for the Future, 2<sup>nd</sup> Edition, Reston VA, February. (<http://www.asce.org/raisethebar>).
8. ASCE Committee on Academic Prerequisites for Professional Programs. 2006. Development of Civil Engineering Curricula Supporting the Body of Knowledge for Professional Practice, Reston VA, December.
9. Fridley, K., et al. 2009. Educating the Future Civil Engineering for the New Civil Engineering Body of Knowledge. Proceedings of the American Society for Engineering Education, Austin, TX.

## Biographical Information

Debra Larson, PhD, PE is the associate dean of the College of Engineering, Forestry and Natural Sciences at Northern Arizona University. Prior to this appointment, she served as the chair for the Department of Civil and Environmental Engineering and before that as Professor of Civil Engineering. Debra is currently serving as chair for the ASEE PSW Section.

# Understanding Histograms, Probability and Probability Density Using MATLAB

Gordana Jovanovic Dolecek<sup>1,2</sup> and fred harris<sup>2</sup>

<sup>1</sup>Department of Electronics Institute INAOE, Puebla, Mexico

E-mail: [gordana@inaoep.mx](mailto:gordana@inaoep.mx)

<sup>2</sup>Department of Electrical Engineering, SDSU San Diego, USA

E-mail: [fred.harris@sdsu.edu](mailto:fred.harris@sdsu.edu)

## Abstract

This paper presents an attractive way to introduce the fundamental terms used to describe a random variable using a MATLAB environment. The Uniform and the Gaussian random variables are considered. The demo programs include histograms, probability, probability density and distribution functions. The results of the evaluation of the program are also presented.

## 1. Introduction

The way engineering is being taught has changed in recent years with the introduction of commercial and educational software that enable and facilitate a better understanding of the subject matter and increased teaching efficiency. Students learn better, remember longer and are better able to identify the appropriate concepts to solve new problems when they learn by addressing concrete problems and actively participate in exploration and pursuit of knowledge<sup>1</sup>.

It is known that random variable is generally considered one of the most abstract and conceptually difficult areas in engineering education and the teaching of random variables is one of the subjects that requires more time for its understanding<sup>2,3</sup>. The use of computers gives students the visual and intuitive representation of the random variables which had traditionally been stated in terms of abstract mathematical description. To this end we present a demo program to aid in, and improve of, understanding the different terms used to describe a random variable.

The programs are written in MATLAB in form of  $m$  files. We choose MATLAB because MATLAB along with the accompanying toolboxes is the tool of choice for most educational and research purposes<sup>4-7</sup>. It provides powerful computation and advanced visualization tools and is also available on a number of hardware platforms.

At each step, the program provides the user with all necessary instructions, including what to do in the next step. Not only passive, but also an active role of the user is required during interactive dialogues prompted through the program. The additional advantage of our approach is that the student does not need MATLAB or any other programming language experience.

The programs can be used as a complement to theoretical classes or alone as a self-study tool. The next section provides a brief description of the probability density and distribution functions, mean value and variance. Third Section presents the demo HISTOGRAMS. The relation of probability with the density and distribution functions is demonstrated in the Fourth Section. Last Section relates the mean value and the variance to the shape of the Gaussian density function.

## 2. Theoretical background

The Cumulative distribution function (CDF) of a random variable  $X$  is defined as the probability that the variable is less or equal to any value of  $x$

$$F_X(x) = P\{X \leq x\}, \quad -\infty < x < \infty. \quad (1)$$

The axioms of probability and their corollaries imply that the distribution has the following properties<sup>8,9</sup>,

1.  $0 \leq F_X(x) \leq 1$ .
2.  $F_X(-\infty) = 0; F_X(\infty) = 1$ .
3.  $F_X(x_1) \leq F_X(x_2); x_1 \leq x_2$ .
4.  $P\{x_1 < X \leq x_2\} = F_X(x_2) - F_X(x_1)$

The probability density function (PDF) of  $X$ , is defined as the derivative of  $F_X(x)$

$$f_X(x) = \frac{dF_X(x)}{dx}. \quad (3)$$

Some properties of the PDF are<sup>8,9</sup>,

1.  $f_X(x) \geq 0$
2.  $\int_{-\infty}^{\infty} f_X(x) dx = 1$
3.  $F_X(x) = \int_{-\infty}^x f_X(x) dx$

When we generate a random variable in a computer we have  $N$  values of random variable. In order to estimate the PDF of the random variable  $X$  we divide the range of the variable into  $M$  equidistant cells of width  $\Delta x$ .

Let  $N_i$  be the number of values of random variable  $X$  that belong to the  $i$ -th cell. Then the probability that the random variable belongs to the  $i$ -th cell is approximated by the quantity  $N_i/N$  called the relative frequency<sup>7</sup>,

$$P\{(i-1)\Delta x < X \leq i\Delta x\} \approx N_i / N, \quad (5)$$

where  $i=1, \dots, M$ .

Using (3) and (2) we estimate PDF in  $i$ -th cell as

$$f_X(i\Delta x) \approx \frac{P\{(i-1)\Delta x < X \leq i\Delta x\}}{\Delta x} = \frac{N_i}{N} \frac{1}{\Delta x} \quad (6)$$

The mean value  $m$  of the random variable  $X$  is defined as

$$m = E\{X\} = \int_{-\infty}^{\infty} xf_X(x)dx. \quad (7)$$

The mean value provides us with very limited information about  $X$ . We are interested not only in the mean of a random variable, but also in variation of random variable about its mean<sup>8</sup>. The variance,  $\sigma_x^2$ , of the random variable  $X$  is defined as the expected average or mean of the squared deviation of  $X$  about its mean value. The parameter  $\sigma_x$ , the square-root of  $\sigma_x^2$ , is called the standard deviation or Root Mean Square (RMS) vale of the random variable.

$$\sigma_x^2 = E\{(X - E\{X\})^2\} = \int_{-\infty}^{\infty} (x - E\{X\})^2 f_X(x)dx. \quad (8)$$

From (6) it follows

$$\sigma_x^2 = E\{X^2\} - m^2, \quad (9)$$

where

$$E\{X^2\} = \int_{-\infty}^{\infty} x^2 f_X(x)dx. \quad (10)$$

The Gaussian random variable has the density

$$f_X(x) = \frac{1}{\sqrt{2\pi}\sigma} e^{-\frac{(x-m)^2}{2\sigma^2}}, \quad -\infty < x < \infty \quad (11)$$

where  $m$  is the mean value,  $\sigma$  is the standard deviation, and  $\sigma^2$  is the variance. The corresponding CDF is

$$F_X(x) = P\{X \leq x\} = \frac{1}{\sqrt{2\pi}\sigma} \int_{-\infty}^x e^{-\frac{(x-m)^2}{2\sigma^2}} dx. \quad (12)$$

The Uniform random variable in the interval  $[R_1, R_2]$  has the density function

$$f_X(x) = \begin{cases} \frac{1}{R_2 - R_1} & R_1 \leq x \leq R_2 \\ 0 & \text{otherwise} \end{cases}. \quad (13)$$

### 3. Histograms

In this demo program we relate the histogram and the probability density function. We consider the uniform random variable in the interval  $[R_1, R_2]$ . The user is asked to choose the number of values  $N$  and the values  $R_1$  and  $R_2$ . Figure 1 shows the plot of the variable for the first 1000 samples of  $N=100000$ , and  $R_1=1, R_2=2$ .

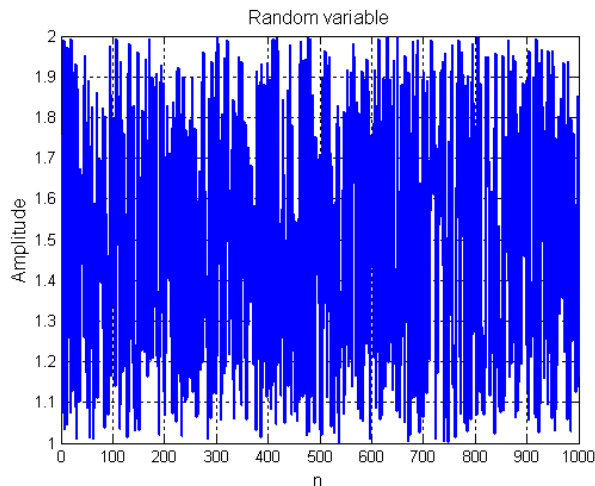


Fig.1. Uniform random variable.

The range of the variable (in this example  $[1, 2]$ ) is divided into  $M$  equal cells. The user chooses the number of cells  $M$ .

HISTOGRAM  $hist(x, M)$  shows the values  $N_i$ ,  $i=1, \dots, M$ , i.e. how many values of the random variable  $x$  are in each cell, where  $M$  is the number of cells. Figure 2 shows the histogram of the uniform random variable for  $M=50$ .

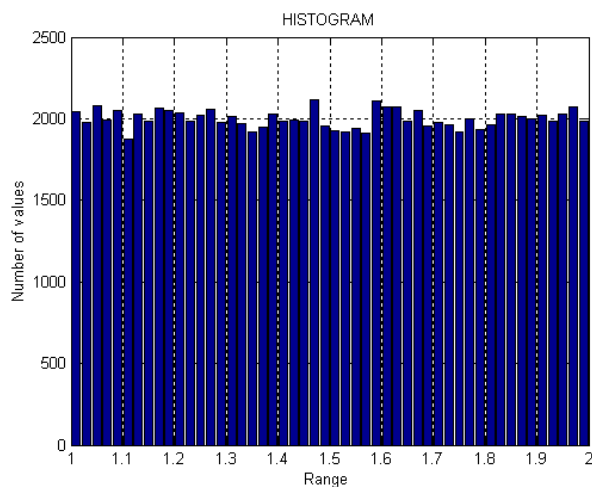


Fig.2. Histogram.

According to (5) we have.

$$P\{X \text{ belongs to the cell}\} = N_i / N = hist(x, M)/N. \quad (14)$$

The plot of the probabilities for all cells is shown in Fig.3.

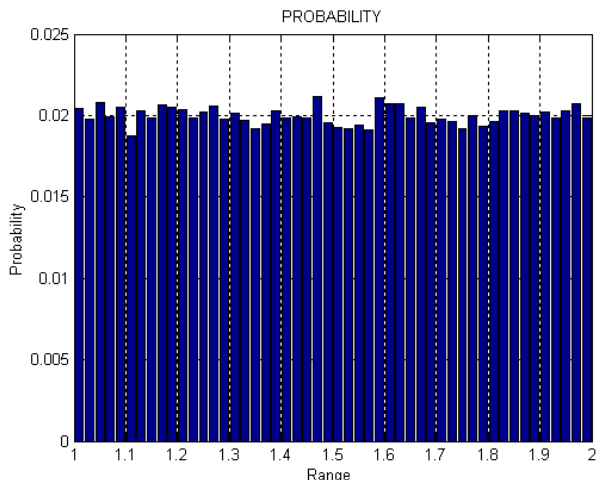


Fig.3. Plot of probabilities.

According to (6) the estimation of the probability density function in the given cell is obtained dividing the probability that the random variable belongs to the cell with the length of cell.

$$PDF = P\{X \text{ belongs to the cell}\} / \Delta = hist(x, M) / (N \Delta), \tag{15}$$

where  $\Delta$  is the length of the cell. The PDF estimation is given in Fig.4.

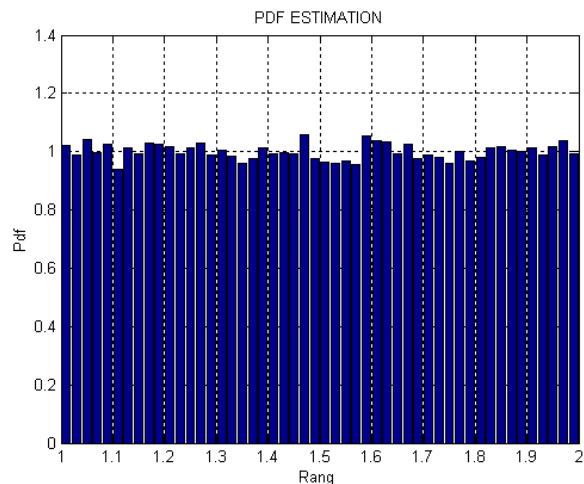


Fig.4. PDF estimation.

#### 4. Probability, PDF and CDF

First we demonstrate how the probability that the random variable  $X$  is less than chosen value  $A$  is related with its density and distribution functions. To this end we generate the Gaussian random variable with the parameters  $m$  and  $\sigma^2$ . Figure 5 shows the Gaussian variable, PDF, and CDF for  $m = 0$  and  $\sigma^2 = 4$ .



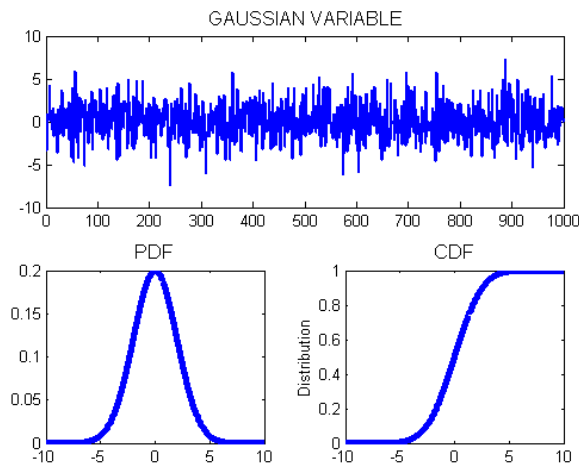


Fig.5. Gaussian variable.

The user chooses the value  $A$  to find the probability that the random variable  $X$  is less than  $A$ , as illustrated in Fig.6 for  $A=2$ . The corresponding probability is equal to 0.8413 and corresponds to the shaded surface under the PDF. The same probability presents the point in CDF at  $n=2$ .

Next, the user is asked to chose the interval  $[B_1, B_2]$  and find the probability that the random variable belongs to this interval, as shown in Fig.7 for the interval  $[-2, 3]$ .

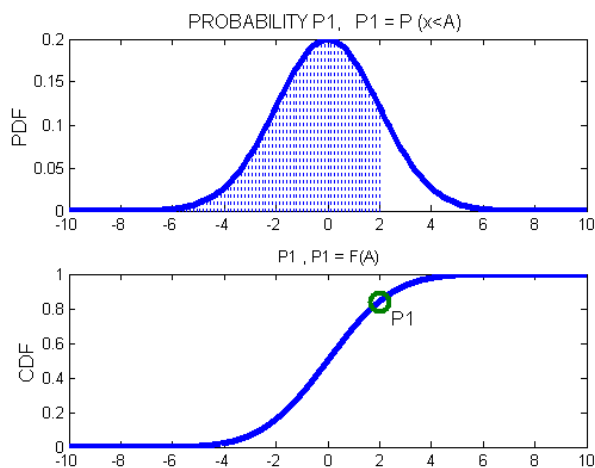


Fig.6. Probability that the random variable  $X$  is less then 2.

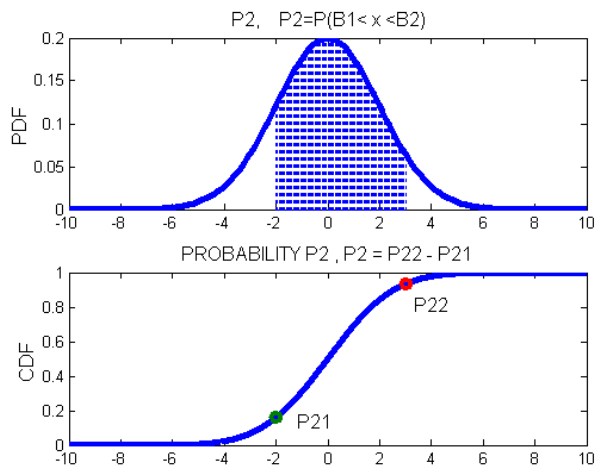


Fig. 7. Probability that the random variable belongs to the interval  $[-2, 3]$ .

The probability corresponds to the shaded area under the PDF and to the difference of the values of CDF at points 2 and 3:  $P_2 = P_{22} - P_{11} = 0.9332 - 0.1587 = 0.7745$ .

### 5. Mean value, Variance and PDF

In this demo program we consider how the mean value and variance affects the shape of the density function. To this end we generate the Gaussian variable with given variance and 4 different mean values, as shown in Fig.8 for  $\sigma^2 = 4$  and  $m = 0, 2, 4,$  and  $6$ .

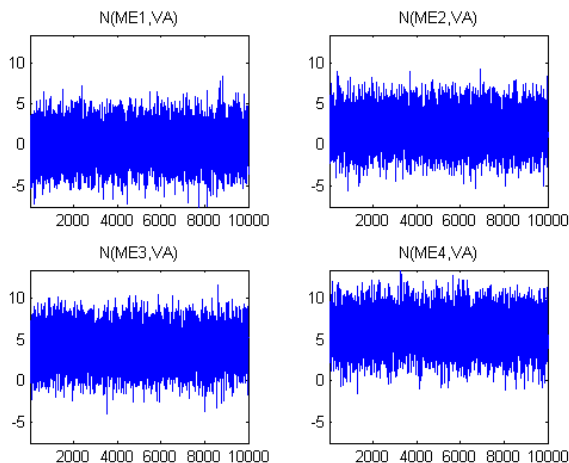


Fig.8. Gaussian variables with different mean values.

Note that the signals show the same behavior but they are displaced around the y axis. The corresponding densities and distributions have the same shape and are translated around the  $x$  axis as demonstrated in Fig.9.

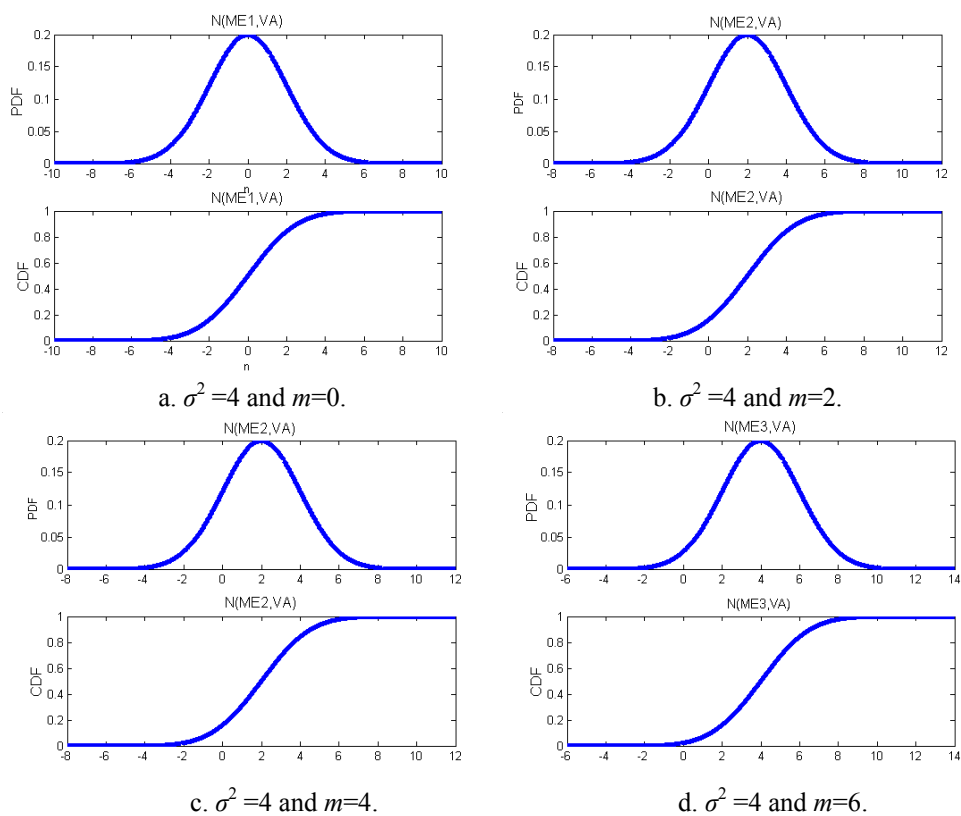
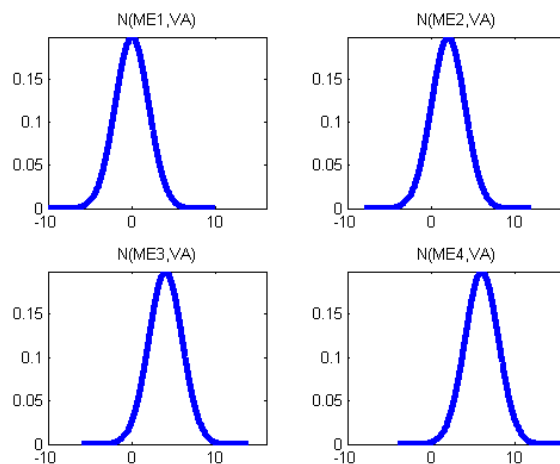
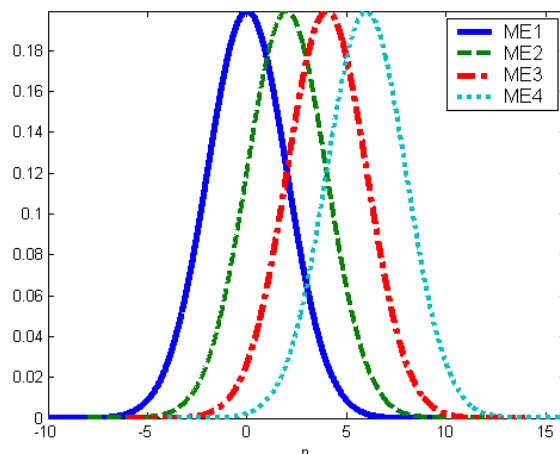


Fig.9. Gaussian densities and distributions.

In order to compare the densities from Fig.9 are again plotted in Fig.10.



a. Gaussian densities.



b. Gaussian densities.

Fig.10. Comparison of Gaussian densities having the same variance and different mean values.

Next we generate the Gaussian variables with the same mean value and the different values of variances. Figure 11 presents the signals for  $m=0$  and  $\sigma^2=1, 4, 9,$  and  $16$ .

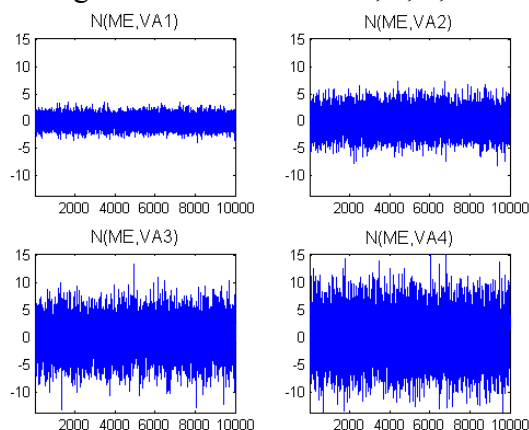


Fig.11.Gaussian variables.

Note that that the Gaussian signals with a high value of variance exhibit more dissipation of its values around its mean value, and vice versa. The corresponding densities and distributions are shown in Fig.12. The densities are compared in Fig.13. The PDF becomes narrower with the decreasing of its variance. Similarly the PDF peak values are decreasing with the increasing of the values of variances. As a consequence, the densities become more spread about its mean value.

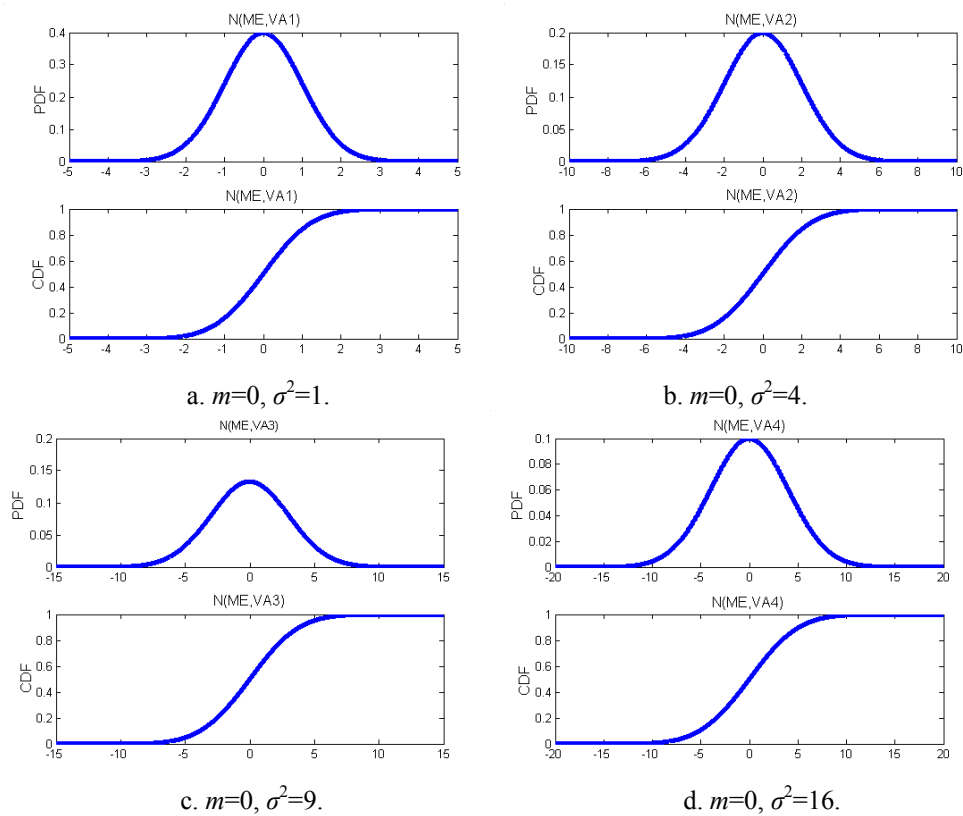
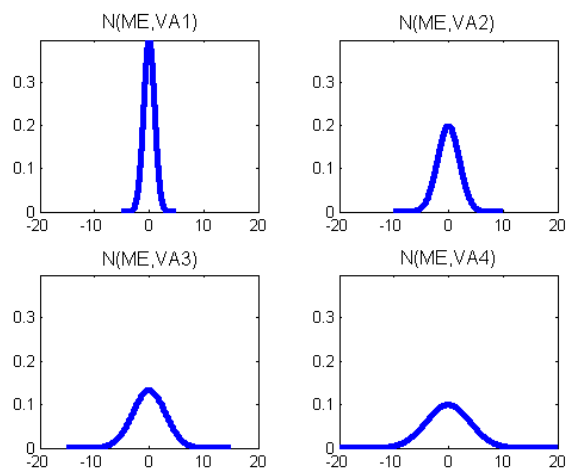
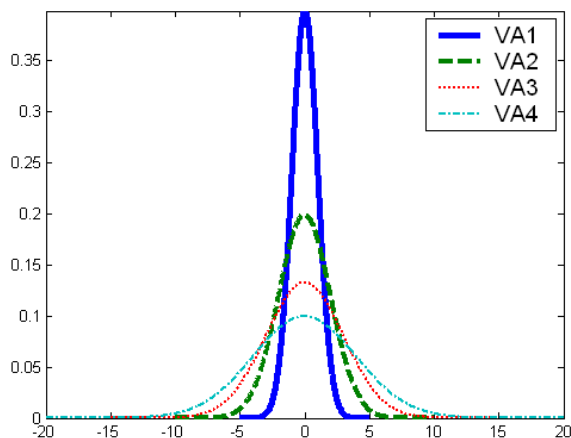


Fig.12. Gaussian densities and distributions.



a. Gaussian densities.



b. Gaussian densities.

Fig.13. Comparisons of Gaussian densities with different variances.

## 6. Evaluation

We consider that an important factor in application of educational software is to measure the usefulness of the software in the teaching-learning process. To this end we defined the evaluation form with set of questions attempted to test the usefulness of the software and the quality of its design features. All questions are rated with marks varying from 1 to 4; with the latter being the highest mark. The following set of questions has been asked:

1. Justification for the computer use in teaching random variables. (1=unjustified; 4=absolutely justified).
2. Contribution to study of random variables by demo program use. (1=irrelevant; 4= very effective).
3. Clarity of explanations and features of demo. (1=confusing; 4=absolutely clear).
4. Did this demo help you to understand better the Histograms & PDF? (1=NO; 4=Absolutely YES).
5. Did this demo help you to understand better the Probability, PDF, &CDF? (1=NO; 4=Absolutely YES).
6. Did this demo help you to understand better the Mean value & PDF? (1=NO; 4=Absolutely YES).
7. Did this demo help you to understand better the Variance & PDF? (1=NO; 4=Absolutely YES).
8. Did this demo help you to understand better the characteristics of Gaussian random variable? (1=NO; 4=Absolutely YES).
9. Special knowledge or programming skills required. (1=excessive; 4=null).
10. Ease of operation. (1=complex; 4= very easy).
11. General quality of presentation (figures, resolution, visibility, etc). ( 1=pure; 4=excellent)

The demo program is used as a complimentary tool to teaching basic course of Random signals and processes. Fig.14 presents the result of the evaluation in terms of the average marks for all questions.

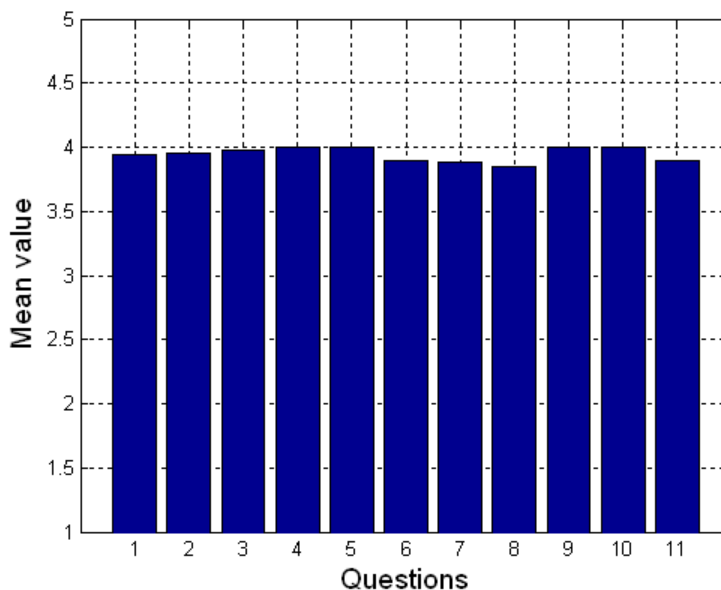


Fig.14. Rating scheme.

The result of the demo evaluation shows that students liked this way of teaching random variables. More specifically, they find this demo very useful for understanding histogram, PDF, probability and the characteristics of Gaussian random variable. They especially highly rated the features of the program; ease of operation, and no programming skills required to run the program.

## 7. Concluding remarks

This paper presents demo program for teaching the fundamental terms used to describe a random variable using a MATLAB environments. However the user does not need MATLAB or any other programming language experience. At each step, the program provides the user with all necessary instructions, including what to do in the next step. Additionally, the advantage of our demo program is that not only passive, but also an active role of the user is required during interactive dialogues prompted through the program. This program has been used to teaching basic course of Random Signals and Processes. Students have evaluated this program as very friendly and useful for better understanding of the basic terms used in random variables and processes.

## Acknowledgement

This work was supported in part by the CONACYT under Grant No. 91013.

## References

1. Li, S. G. and Lie, Q. (2004). Interactive Groundwater (IGW): An Innovative Digital Laboratory for Groundwater Education and Research, *Computer Applications in Engineering Education*, 11(4), 179-203.
2. Jovanovic Dolecek, G. (1997). RANDEMO: Educational Software for Random Signal Analysis, *Computer Applications in Engineering Education*, 5 (2), 93-99.
3. Quere, R., Lalande, M., Boutin, J. N., and Valente, C. (1995). An Automatic Characterization of Gaussian Noise Source for Undergraduate Electronics Laboratory, *IEEE Transaction on Education*, vol.38, No2, 126-130.
4. Kim A. S., Park C., and Park, S. H. (2003). Development of web-based Engineering Numerical Software (WENS) Using MATLAB: Applications to Linear Algebra, *Computer Applications in Engineering Education*, 11 (2), 67-75.
5. Orsak G. C., Etter D. M. (1995). Collaborative Signal Processing Education Using the Internet and MATLAB. *IEEE Signal Processing Magazine*, 12 (6), 23-32.
6. Pires V. F. and Silva J. F. A. (2002). Teaching Nonlinear Modeling, Simulation and Control of Electronic Power Converters Using MATLAB/SIMULINK, *IEEE Trans. Education*, 45(3), 253-261.
7. Prabhu G. S., and Shankar P. M. (2002) Simulation of Flat Fading Using MATLAB for Classroom Instructions, *IEEE Trans. Education*, 45(2), 19-25.
8. Leon-Garcia, A. (2008). *Probability and Random Processes for Electrical Engineering*, New Jersey, 3<sup>th</sup> edition, Prentice Hall.
9. Jovanovic Dolecek, G. (1985). *Random Variables and Processes in Communications*, Sarajevo, Svjetlost.

**Gordana Jovanovic Dolecek** received a BS degree from the Department of Electrical Engineering, University of Sarajevo, an MSc degree from University of Belgrade, and a PhD degree from the Faculty of Electrical Engineering, University of Sarajevo. She was professor at the Faculty of Electrical Engineering, University of Sarajevo until 1993, and 1993-1995 she was with the Institute Mihailo Pupin, Belgrade. In 1995 she joined Institute INAOE, Department for Electronics, Puebla, Mexico, where she works as a professor and researcher. During 2001-2002 and 2006 she was with Department of Electrical & Computer Engineering, University of California, Santa Barbara, as visiting researcher. She is currently with San Diego State University as visiting researcher on a sabbatical leave. She is the author of three books, editor of one book, and author of more than 200 papers. Her research interests include digital signal processing and digital communications. She is a Senior member of IEEE, the member of Mexican Academy of Science, and the member of National Researcher System (SNI) Mexico.

**fred harris** is professor of Electrical and Computer Engineering at San Diego State University, where he holds the CUBIC Signal Processing Chair of the Communication Systems and Signal Processing Institute. He has extensive practical experience applying his skills to satellite and cable TV communication systems, wire-line and wireless modems, underwater acoustics, advanced radar and high performance laboratory instrumentation. He holds several patents on digital receiver and DSP technology, lectures on DSP worldwide, and consults for organizations requiring high performance DSP systems including the SPAWAR, Lockheed, Cubic, Hughes, Rockwell, Northrop Grumman, SAIC, GDE, and Motorola. He has published over 160 papers and has contributed to a number of books on DSP. In 1990 and 1991 he was the Technical and then the General Chair of the Asilomar Conference on Signals, Systems, and Computers which meets annually in Pacific Grove, California. He is Editor of Signal Processing, Journal of Elsevier. He is the author of the Prentice-Hall textbook "Multirate Signal Processing for Communication Systems" and is a Life Fellow of the IEEE.



## From Sequential to Parallel

Ranjan K. Sen, Microsoft Corporation  
Pradip Peter Dey, National University

### Abstract

There is an urgent need for traditional programmers who write programs meant for a single processor to be able to modify or write new codes for multiple processor machines. Unfortunately, writing parallel programs has been esoteric, considered too complex and had been confined to a few developers. This paper presents Microsoft .NET framework versions and enhancements that provide modern approaches that are relatively easy for traditional programmers to learn rapidly and use. These new technologies provide support for both shared memory as well as distributed memory parallel programming models such as a decentralized software service model. However, the presentation of these technologies needs to build on the general background of the stored programmed memory model used by the traditional programmer. It needs to add structures that enable them to incrementally move from sequential model to the parallel model of computation. The goal of the paper is to present a comprehensive structure that integrates the parallel programming model with the sequential model and introduces the technologies in this context. The paper argues that a second level programming course should be based on such an approach. Such a course will be useful for students as well as professional programmers who need this new skill in the light of more and more multi-core, many-core and cluster based commodity multi-computing.

### 1. Problem statement

Parallel programming has traditionally been a highly specialized area of programming. Interestingly a very limited aspect of parallel processing is often known to traditional sequential programmer. This is multi-threading and is used to improve response time by off loading slow computations such as input/outputs to a thread different from the main thread. However, in parallel programming one is interested to distributed data/code to run concurrently as well as ensure proper coordination to ensure the sum total of these computations produce the result correctly. This requires a more sophisticated programming model and development approach suited for the purpose.

Due to diverse hardware architectures, environments and approaches the meaning of parallel programs incorporated features that ranged from instruction level, data array to higher level concurrency. This has resulted in different models such as data parallel, task parallel, asynchronous, dataflow, agent based as well as distributed parallel programming. All of this has added to the complexity of parallel programming. The good news however is that considerable experience in parallel programming has taken place over the last more than 4 decades and a rich body of knowledge is available. The bad news is parallel programming looks very complex to most sequential programmers.

There has been recognition of the fact that it is urgently needed to offer training in parallel programming to students in general and pro developers as well. Most of them however, have hardly looked at a bridging approach where a sequential programmer is gradually moved to the world of

parallel programming. For example, the course proposed in [1] includes all the aspects of parallel programming such as algorithm design, architectural constraints, programming approaches such as SPMD, mapping and scheduling as well as parallel databases. Students use parallel programming languages and tools such as OpenMP [2, 3, 4] for C/C++ with MS Visual Studio 2005 and Intel C/C++ compiler. Debugging tools include VTune, and threading tools include Intel Thread Profiler and Intel Thread Checker. However, it ignores two important issues –

- 1) Limitations to “think parallel” without support from a suitable environment
- 2) The scores of existing developers with developing programming skills for conventional sequentially executing computers.

Our contention is that the approach should be that a sequential (one processor) computation model, as exemplified via conventional sequential programs, is not being replaced by parallel computation model but simply being extended. The approach we need is to add parallel programming as an extension to existing courses on sequential programming and architecture.

We believe that point 1) will be address by building a connection to the common stored program model used in sequential programming from parallel programming models. Point 2) will be addressed by programming extensions (implemented possibly in multiple ways).

This paper presents a proposal for developing a second level course in this approach. Such a course may be part of the engineering curricula while being available to professionals desiring to upgrade their skill sets. This course is intended to demonstrate that using appropriate tools and environments sequential programming ideas can be broadened in order to progressively reduce the cognitive gap between sequential and parallel program development.

As a starting point, in section 2 we identify basic concepts all programmers seem to be aware of. We highlight aspects of computing model, languages and system as well as idea of multi-threading. In section 3 we present the concepts in parallel computing and discuss how they relate to concepts identified in the earlier section. In the next section we further explain the parallel computing concepts emphasizing the role of coordination. Finally in the following section we present the outline of a course designed in this approach.

## **2. Concepts programmers know**

The most widely used model for sequential computation is the von-Neumann stored programming model. This model consists of a processor, a program, data and memory. The program is a sequence of instructions that the processor executes when directed by a program counter/instruction pointer. There are various forms of memory such as registers, random access memory, and secondary memory etc. There are external devices that can communicate to the processors.

An algorithm is a high level representation of a program. It consists of steps of statements that is unambiguous and may be interpreted by a computer. An algorithm must terminate. An algorithm is

used to reason about a specific recipe to solve a problem using a computer. It is implemented as a program using programming language.

A programming language is one that can express an algorithm and may be compiled into a low level program that may be directly executed by the computer hardware. The computer hardware recognizes programs stored in the memory and executes it instructions one by one as pointed to by the program counter. One instruction is executed at a time by the single processor.

### 2.1 High level language

Programmers write programs using a high level language such as C#, C++ etc. these languages allow various programming structures to help developing programs, reusing existing programs or its parts, composing programs using parts, ensuring semantic guarantee (delivers what it supposed to mean all the time), ... The notion of assignment, condition checking, read/write, mathematical operations, data and types of data are very natural to human understanding of computational domain. Composite data such as collections, containers are common. Modern programming environment provide support for using multiple programming languages, using run time just in time compilation that optimizes use of the available infrastructure and various other development tools. Note that the underlying programming model provided is still the stored program model.

### 2.2 Operating Systems

Programmers understand the role of the operating system in managing computing resource among multiple users. They often use operating system services programmatically. For example, in dynamically allocating memory it uses the memory allocation services, in acquiring a network port it uses socket service of underlying network system.

### 2.3 Data and Database

Programmers recognize the value of associating a type with a data, composing data in databases for efficient storage and retrievals. They are aware of the mechanisms used for opening database, connecting to it, querying for information etc.

### 2.4 Network and distributed processing

Network is how computers connect to each other and other devices of various types. They know the different protocols used in such communications. They are aware of ports that are the interface to a computer and machine network addresses.

### 2.5 Multi-threading

One important understanding in this context is the role of a processor which is the key element of a computer. Mechanism for offloading processors computational load via threads is quite well known. This is to avoid long waiting time for an interactive user. This requires dividing into several pieces of

computations and maintaining their state. This type of support is provided by most operating systems today.

### 3. Parallel processing concepts

Parallel processing may be viewed as several computations taking place at the same time or concurrently. The notion of “same time” needs a bit of a clarification. If the state of computations is maintained in a computer with only one processor so that any of them may be started, halted before completion, another computation that might have been halted restarted then we are doing parallel processing. In case of multiple processors it is possible to have two or more computations actually running simultaneously.

Overall the notion is to be able to declare computational tasks that may be scheduled to available processors. Each computational task runs on a single processor when it is scheduled to it. Thinking in this way, a parallel process is the agglomeration of tasks. Each task corresponds to a program or a segment of a program that runs on a single processor in a sequential manner. However, such a task may be stopped and saved unfinished to allow another task to use the processor if necessary. The stopped task may resume in the future on this or another processor.

The overall conceptual approach is given by:

$$\text{Parallel program} = \text{Sequential Program} + \text{coordination (communication)}$$

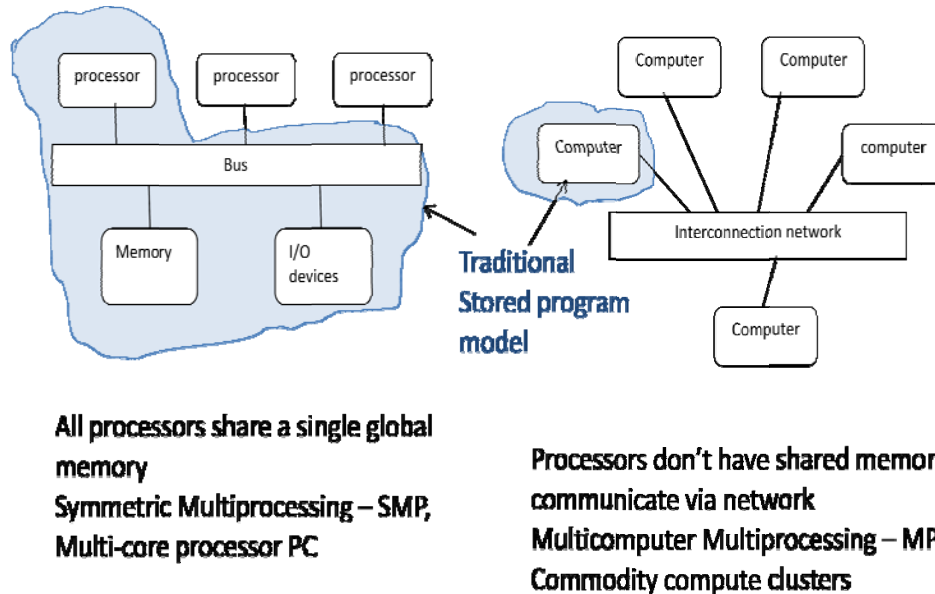
Programs process data. The basic goal is to produce an output from input via steps of computations; some of which can take place concurrently in parallel programs. We can analyze the overall process and determine the input-output dependencies amongst the sequentially executing instances. The input of one instance may be generated as output of another. Similarly more than one instance may need the same input. Some of the computational operations on such data are safe if performed by one instance and not so, if performed by several at the same time. This is the limitations associated with the underlying hardware commonly available. In parallel programming we get around this issue by a coordination discipline. One common type is programming mechanisms such as locks and semaphores.

#### 3.1 Coordination

The new concept learners need to understand is that of coordination because they are already aware of concepts in sequential program. One can think of multiple programs running at the same time where each may potentially impact behavior of the other directly (via altering common data) or indirectly (by blocking a resource resulting in the other programming not able to proceed or in deadlock) unless the input-output relations is ascertained to be correct from both a spatial as well as temporal point of view. The first is enforced easily in conventional memories (Random Access Model) but the later requires ordering discipline generally implemented via synchronization primitives similar to those used in operating system design.

### 3.2 Use of programming model

Parallel computer programming models incorporated the idea of coordination via memory or message passing operations. Often these are too low level and lack the high level structure and pattern that is commonly shared across parallel applications. The two corresponding models are the shared memory and the distributed memory models of parallel programming.



The shared memory model is also known as the symmetric multiprocessing or SMP where cost of data access by different sequential program instances of a parallel computation are the same. This assumption is not necessarily always valid, say when intermediate memory caches are used to cut down on memory access overhead.

With more and more such instances the contention for memory impacts this cost limiting scalability of the parallel program. This prompted distribution of the memory in the distributed memory model. However, this requires multi-staging of memory using caches and external networking. Additionally, data access from memory often requires explicit network communication. This model is also called the Multi-computer Parallel Processing or MPP. Language extensions and libraries to support these models are well known – Open MP [2-5] for shared memory while MPI [5, 6] and PVM [7] for distributed memory models. MPI has become very popular as it is easily available to run on commodity clusters of computers. With the advent of multi-core and multi-computers, hardware accelerators such as FPGA, graphic processor matrix a complete overhaul of software development to move to parallel processing is warranted today.

### 3.3 Languages and libraries:

Most programming languages support “threads” which is the unit of computation scheduled by operating systems. Windows provide API for using thread objects; UNIX pthreads library offers similar functionality. Developing and maintaining parallel programs at the thread level is low level. Language

structures suitable for parallel processing based on appropriate programming models are known. Parallel version of popular languages such as FORTRAN, C, C++ were developed and used. Unfortunately, these tended to be proprietary and expensive. Approaches based special compiler directives as in OpenMP, on libraries such as MPI and PVM were more popular and are currently widely used. The libraries are available from more than one programming languages.

Among other popular libraries are the TBL from Intel, AMD. Among compilers is the Cilk++ compiler which is an extension of industry standard compiler, the native extensions and optimization of the base compiler is fully supported. The underlying model is the shared memory model in all of these except for MPI and PVM which are based on distributed memory model.

#### **4. Extending concepts to include parallel processing**

Although considerable research and development has taken place in the area of parallel processing during the last several decades the idea of a novel parallel processing language never succeeded. The approach that worked has been that taken up by Open MP and MPI/PVM. One concern is though that both avoids calling out a concept of “computation” as a distributable object as a first class entity. This has been to avoid intruding into common language standards and concepts. In particular the languages did not provide appropriate options to build such an object.

Going back to the equations used above and reprinted here for convenience, we draw attention to the role of coordination/communication in design and development of parallel programs.

$$\text{Parallel program} = \text{Sequential Program} + \text{coordination (communication)}$$

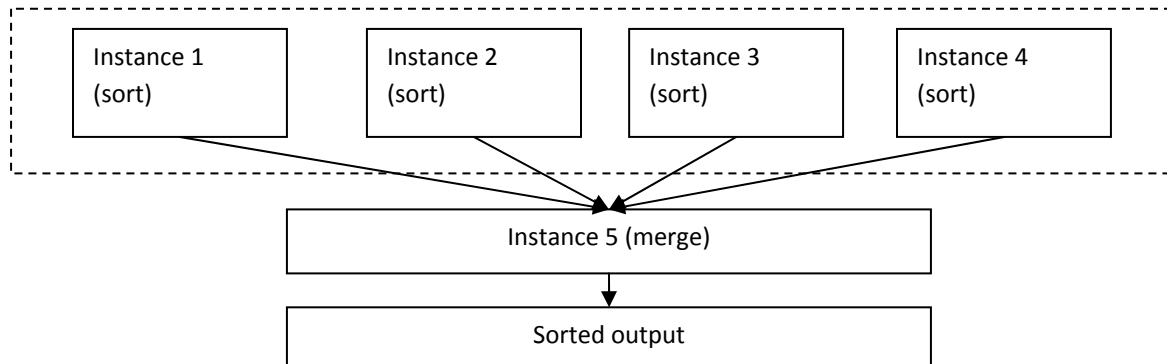
We need a first class representation of a sequential program as a computation in the language or its extension.

Looking at the topic of coordination observe that this depends upon the programming model to be used. For example in a shared memory model all coordination needs to happen by coordinating access to the shared memory. Alternately, if the model is a distributed memory model then such coordination is completely done via message passing often in an asynchronous manner.

This needs the new concept of coordination in shared memory and via message passing to be learnt. Considerable knowledge in both areas, albeit in different context, has been known to us. The goal is to identify them and present them in a unified and structured manner. This will be discussed in the next section.

At this point let us consider the simple example below of sorting a set of numbers:

Assuming parallel instances of several sequential sort programs we can visualize the enter operation as that of sort followed by merging of the sorted parts. This imposes input-output dependencies between the instance executions, shown with arrows.



Note that there is no need for direct coordination between the instances performing sort, while the merge instance may only execute after all sort operations are completed.

#### 4. 1 Contrasting sequential and parallel algorithms

Sequential algorithms use three alternate models for algorithm analysis – RAM, RASP and the Turing machine. Parallel algorithms are essentially extension of a sequential algorithm model. The main ones for shared memory models are PRAM (Parallel RAM) and their variations such as EREW, CREW, and CRCW based on support for concurrent access to memory. Similar models are available for analysis of parallel algorithms targeted for distributed memory parallel computers. Excellent treaties on this is in [13]

In the above example, a PRAM model based algorithm is:

1. Do in parallel { Instance 1, Instance 2, Instance 3, Instance 4}
2. Merge sorted outputs from Instance 1, Instance 2, Instance 3, Instance 4 to create Instance 5
3. Print out the sorted output

Each instance in step 1 uses a sequential sorting algorithm that sorts one of four blocks of the total data to be sorted. The step 2 involves coordination of outputs produced by the four instances of step 1. It is evident that the characteristics of the algorithm depend on size of the blocks, speed of sequential computations, speed of coordination etc. For example, the time taken for step 1 is given by the maximum time spent by an instance of the four being executed. That of step 2 is given by the merging scheme etc.

Several coordination primitives and patterns are used in parallel programming. It is important to understand which should be used when. In the context of shared memory model most common primitives are those conventionally used for multi-threading and known in the OS context. This is quite known to traditional sequential developers as well as synchronization primitives.

Higher order synchronization and coordination primitives such as monitors, semaphores etc are built with lower ones such as locks. Principles and structures such as mutual exclusion, reader-writer paradigms are build from smaller primitives. Updating a variable in memory concurrently may lead to

unpredictable or non-deterministic value. This is due to race between concurrent operations that modify it. Locks are used to coordinate access to the variable by concurrent operations such that only one may deterministically modify it. This idea may be extended to larger data structures common in programming – such as stacks, queues, lists etc.

Patterns such as reduction ... and generic schemes such as “map-reduce”, “data-parallel”, “task-parallel” are even higher level coordination schemes. These are actually the parallel algorithms we mentioned before. In the data parallel context sequential programs run on independent sets of data concurrently and there is no coordination necessary between them. Task parallel scheme defines independent computational blocks, known as tasks where having maximum fan-out in terms of maximum number of tasks to run concurrently lead to maximum speed up.

a) Task parallelism

Tasks can execute concurrently when there are no dependencies among them. Examples include “ray-tracing” in image processing and Monte Carlo simulation programs. In some cases, it is possible to modify data and instructions to create independent tasks and engage task parallelism.

b) Divide and conquer

This is similar to the parallel reduction scheme used for developing the maximum finding program. This general scheme is very popular in developing sequential as well as in parallel algorithms. In case of parallel algorithm the goal is to decompose to an extent that makes sense for the individual processors.

c) Geometric Decomposition

In this approach the relationship of the data influences the pattern. For example, in computational fluid flow problem, operations on matrix element require only neighboring data. In such a case, the matrix geometry is used to formulate tasks. Also in matrix multiplication checker-board algorithms use geometric relationship.

d) Recursive data pattern

Many sequential algorithms use recursive processing. In many cases these can be split into partitions. Processing recursively can occur in parallel across these partitions. Overall computation can be formulated as a sequence of parallel recursive operations followed by synchronization.

e) Pipelined

A sequence of tasks can be executed in such a way that a processor is kept working all the time. For example, in case of executing a for-loop in a program, if there is no data dependency and



resource conflict, the first instruction (or task) of the  $n+1$ th loop can start executing immediately after the first instruction (or task) of the  $n$ -th loop has completed.

#### 4.2 Task and data parallelism

When we partition the computation into tasks and execute them in parallel we get task parallelism. In this case data is not partitioned. Flynn's taxonomy gives four variations in task parallelism of which three are useful – Single Instruction Single Data (SISD), Single Instruction Multiple Data (SIMD), Multiple Instruction Multiple Data (MIMD).

When we partition data but not partition the tasks we have data parallelism. Data parallelism is a convenient way to introduce parallelism when operational dependency does not involve the entire data. This approach is very popular and gives rise to a specialized model of the distributed memory parallel computer called Single Program Multiple Data (SPMD).

#### 4.3 Role of Synchronization

A key concept in coordination is synchronization. This process enforces a synchronous mode of computation in which (the time of) a set of computations are hidden by time period. The intent is to ensure all computations are completed when that period or "clock" cycle is complete. This is a way to impose deterministic state properties. This is very close to the shared memory model. A popular variation in array processing is the systolic architecture.

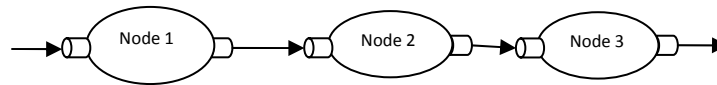
In a computation that does not use synchronization via clock; or in an asynchronous mode of computation, instructions may interact via generation of data or events. One common methodology known to conventional sequential programmers is to use events and call backs. Dataflow is a well known asynchronous parallel computing model. Other models include demand-flow or lazy-evaluation where a computation is performed only when its results are asked for or demanded.

Coordination algorithms may be implemented imperatively in code, in hardware network such as shuffle-exchange network, gate arrays, and distributed services and so on. Much of the coordination is embedded in the structure and topology of the network itself.

#### 4.4 Network and arrays

Parallel coordination algorithms are implemented in arrays via simple messages or dataflow across them. In case of arrays of identical processors performing similar computations pipelined patterns are easily incorporated.

An algorithm for sorting on a linear array of three processors is given below. Note how the coordination scheme is somewhat embedded in the topology of the linear array. Note each node of the linear array sorts a block of data. Each node has an input and output port that establishes the linear relationship among them. We assume  $N$  data is being sorted, each node perform a sequential sort on  $N/3$  using a simple insertion sort scheme.



Initially each node reads elements from its input and merges them into an internal sorted sequence of  $N/3$  data.

1. Post  $N$  data at the input of node 1
2. Each node do in parallel {

Read data from input and create sorted sequence locally;  
Pass data smaller than the smallest element in the sorted  $N/3$   
sequence to the output port

}

3. Output sorted sequence

A systolic approach can clock the transmission of data across the network. A service oriented scheme based on CCR/DSS parallel technology supports this in an asynchronous parallel processing scheme.

#### 4.6 Speedup and performance

A key point in parallel processing is performance. Speedup is given by the ratio of time taken by sequential program to the time taken by parallel program. Theoretical limits given by Amdahl's law or Boris-Gustafson's law are well known. It is important to understand concepts of speedup, and performance scalability.

This requires one to be able to understand the algorithmic issues governed by patterns, platform issues governed by the hardware and operating system that impact performance. One should be able to relate performance to code via tools such as profiler, which is rarely used in developing sequential programs.

Debugging parallel programs is difficult. This requires learning to reason about program behavior under multi-processing environment as well as knowing appropriate tools.

Aspects of availability, reliability and fault-tolerance are somewhat advanced topics. However, they should be related to the integrated approach we discuss here.

### 5. Foundation course

We present an high level outline of a course that help introduce parallel programming to students that have completed one or more traditional programming course. It is useful to professional programmers who have experience in programming single processor computers. The items below point to key topic areas that should be covered in such a course. It also gives relative hours to spend with a percent value for each topic.

- Executing code on a thread – understand the concept of computation in conventional programming environment.
- Developing algorithms – how a program has an underlying algorithm. How to look at an algorithm to reason about a program – correctness, performance and boundaries (max input size, type of input to process, any data ranges, accuracy of output etc.)
- Understanding parallel algorithms – sequential programs and coordination. Extending a sequential program into a parallel program. Identify sequential pieces, coordination process, any extension of boundary (improving performance – processing more data quicker, improving accuracy of data or range of data etc). Concepts of speed up and scale up. Ideal case of linear speed up, super-linear speed up etc. Compute to communication ratio limits speed up.
- Abstracting coordination – patterns. Consider other sequential programs and attempt to parallelize. Look at a good number of problems and identify patterns. At least 5 to 6 different types of patterns need to be discussed.
- Concurrency models – shared memory and distributed. Approach to developing parallel program. Type of model to choose and what type of programming languages etc.
- Scheduling and mapping – how does computational resource usage relate to parallel programming

We believe that the Microsoft .NET Framework and the latest Visual Studio 2010 (CTP available) includes rich set of parallel technology that can be used to develop such a course. This has been presented in Appendix I.

Appendix II illustrates features of the Microsoft .NET Framework parallel processing technology in providing a modern, rich approach to present the course in the above approach. It allows efficient delivery of the concept and approach of the course outlined. This is because we can quickly demonstrate how patterns such as data parallel, task parallel or service oriented design can be formulated in a modern programming environment around C# and Visual Studio. The availability of high quality development, debugging, profiling in the Visual Studio makes delivery of this course more efficient than other alternatives as understood by the authors. The goal is to provide the concepts and theories with complementary hands on experience. The balance can be only maintained with such a modern programming environment.

## 6. Conclusions

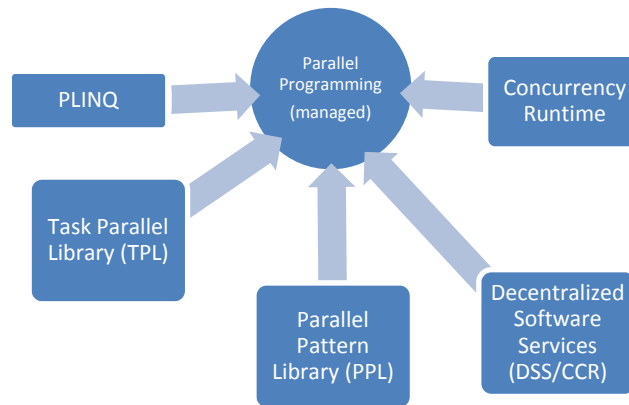
In summary the approach we propose is based on existing programming knowledge and practice of traditional sequential developers. The relationship between sequential and parallel programs/computations is a key underlying theme. The issue of parallel programming is viewed mainly as that of framing up the coordination patterns among sequential pieces. The area of sequential and parallel algorithm analysis and design is very well developed. In most Computer Science and Engineering curricula the first is usually covered. Correctness, performance and issues such as reliability, availability need to get due coverage. Tools for debugging and profiling can be introduced as part of the curriculum in this context.

## References

- 1) *Think Parallel: Teaching Parallel Programming Today*, Ami Marowka, Shenkar College of Engineering and Design, Israel, 2008 <http://dsonline.computer.org/portal/site/dsonline/index.jsp>
- 2) Chandra, R., Dagum, L., Kohr, D., Maydan, D., McDonald, J., & Menon, R. (2000) *Parallel Programming in OpenMP*, Morgan Kaufmann, 2000.
- 3) *The OpenMP API specification for parallel programming*, <http://openmp.org/wp/>
- 4) Chapman, B. , Jost, G., & Van der Pas, R. (2007) *Using OpenMP: Portable Shared Memory Parallel Programming*, MIT Press, 2007.
- 5) Quinn, M.J. (2004) *Parallel Programming in C with MPI and OpenMP*, McGraw-Hill, 2004.
- 6) Karniadakis, G., Kirby II, R. M. (2003) *Parallel Scientific Computing in C++ and MPI: A Seamless Approach to Parallel Algorithms and their Implementation*, Cambridge University Press.
- 7) Geist, A., Beguelin, A., Dongarra, J., Jiang, W., Manchek, R., Sunderam, V. S. (1994) *PVM: Parallel Virtual Machine: A Users' Guide and Tutorial for Network Parallel Computing*, MIT Press, 1994.
- 8) M. Paprzycki, "Integrating Parallel and Distributed Computing in Computer Science Curricula," *IEEE Distributed Systems Online*, vol. 7, no. 2, 2006, <http://doi.ieeecomputersociety.org/10.1109/MDSO.2006.9>.
- 9) I. Foster, *Designing and Building Parallel Programs*, Addison-Wesley, 1995, [www-unix.mcs.anl.gov/dbpp/text/book.html](http://www-unix.mcs.anl.gov/dbpp/text/book.html).
- 10) *Cilk Arts*: <http://www.cilk.com/multicore-products/cilk-solution-overview>
- 11) *The Manycore Shift: Microsoft Parallel Computing Initiative Ushers Computing into the Next Era (2007)*, <http://www.microsoft.com/downloads/details.aspx?FamilyId=633F9F08-AAD9-46C4-8CAE-B204472838E1&displaylang=en>
- 12) *Overview of Synchronization Primitives* <http://msdn.microsoft.com/en-us/library/ms228964.aspx>
- 13) T. Leighton, *Introduction to Parallel Algorithms and Architectures: Arrays:Trees:Hypercubes* - Morgan Kaufmann, 1992.

## Appendix I: Microsoft Parallel Processing Technology

Recent .NET Framework, 3.0 and later versions of .NET Frameworks support more than one high level parallel processing technologies (see figure). These provide the high level programming model missing in the legacy thread models.



The DSS/CCR runs in .NET Framework 3.0 (and 3.5) runtime. It provides an asynchronous message oriented programming model. This model helps develop a loosely coupled multi-task computing solution. It is available as a DSS/CCR development kit and also as part of the Microsoft Robotics Studio<sup>1</sup>.

The remaining technology, available as libraries and core runtime, is part of the Microsoft .NET Framework 4.0. A Community Tech Release (CTP) for Visual Studio 2010 contains this.

PLINQ allows automatic parallelization of LINQ queries. The Thread Parallel Library (TPL) is available to be used for managed development in C#, and VB. The Parallel Patterns Library (PPL) as well as the asynchronous agent technology provides support for parallel development for native C++. The Concurrency Runtime provides the runtime to host the parallel objects. Additionally, new profiler tools are available for parallel programs.

### The Windows HPC Server

The latest release of Windows HPC Server is based on .NET Framework 3.0 and provides a top notch modern and highly secured HPC run time environment. There is a Window HPC Pack that provides high quality administration, management, monitoring tools along with a top notch job scheduler. The Windows HPC Server data sheet, doc, case studies and licensing is available (see technology links table). The Windows HPC server is a supercomputer quality product as evidenced by the 10<sup>th</sup> rank in the international top500 list. It provides all traditional HPC application development support and has Microsoft MPI library based on MPICH2. This makes easy port of tradition MPI applications.

<sup>1</sup> CCR and the Asynchronous Programming Model (ref. <http://msdn.microsoft.com/en-us/library/bb977678.aspx>)

Additionally, it provides latest features such as SOA job definition and scheduling in addition to standard options of diverse schedule policies, integration with third-party scheduling services and the international grid computing standards such as HPCBP. It integrates Windows management and monitoring services leading to fast deployment support via Windows Management and Operations (MOM); system health reporting via Windows System Management Services (SMS) leading to high productivity computing in addition to high performance computing. Extensive world class support from Microsoft as well as third party for development, deployment and infrastructure are available.

#### Microsoft .NET Parallel Library

C# is a modern programming language that expresses events, objects, threads, lambda functions, anonymous delegates and callback methodologies. The new parallel library in .NET Framework 4.0 builds on these core language features. These libraries are usable from any .NET languages and directly supported on VB.NET and C++/CLI<sup>2</sup>. It is a runtime library instead of a compiler solution as Open MP

The primary goal of this library is simplify the development of parallel programs in .NET environment. It addresses the developer community who are accustomed to C# or other .NET programming languages, though in the traditional sequential programming point of viewpoint. The programming model therefore adheres to the shared memory model of parallel computing.

---

<sup>2</sup> Parallel Computing <http://msdn.microsoft.com/en-us/concurrency/default.aspx>

## Appendix II: Microsoft Parallel Processing Technology

Microsoft .NET Parallel Extension library and the CCR/DSS asynchronous service oriented parallel processing technology are well suited to present the materials presented in the proposed course above. We present a few examples. We assume knowledge of C# 2.0.

As a developer steps into the realm of parallel programming easy but efficient schemes of parallel computing – such as data parallelism can quickly demonstrate the benefits. Data parallel feature is made available as a new extended type (Parallel) in the .NET 4.0. in the System.Threading namespace quite known to most .NET developers using multi-threading.

The Parallel type has For and ForEach methods to convert sequential iterations (for-loops, foreach-loops) into concurrently running sequential blocks of programs efficiently. The methods create suitable number of sequential blocks depending upon the number of processors in the underlying machine. This is done via the thread scheduling mechanisms in the .NET Framework along with Windows operating system. Having higher level types for defining parallelism hides the common developer pains associated with manually implementing this using low level Thread objects. However, a well disciplined approach to parallelization is not compromised.

If loop iterations are independent, i.e. no iteration need any value computed in another, then one can use suitable methods such as Parallel.For and pass the loop body and parameters as a delegate. A for loop of the type,

```
For (int i = 0; i < N; i++) results[i] = Compute(i);
```

may be converted to a version as follows, where each iteration may run concurrently.

```
using System.Threading;
...
Parallel.For(0, N, delegate(int i) {
    results[i] = Compute(i);
});
```

This is a call to the static For method of the Parallel type. The method takes the starting, ending values of parameter i for the delegate and the function is invoked for each value of i. Conceptually, this is very close to the loop structure and there is no need to add additional synchronization rules. This is so because there is no need for any coordination among the different calls.

The Parallel.ForEach method is used for looping over IEnumerable<T> objects. Since this method is part of .NET library, it can work with other .NET languages such as VB.NET or F#<sup>3</sup>.

Parallel LINQ provides an easy to use parallelizing mechanism for LINQ queries<sup>4</sup>. This is very similar to the data parallel constructs. Again, the goal is to simplify adoption of parallel programming for conventional sequential programmers.

---

<sup>3</sup> Microsoft F# <http://msdn.microsoft.com/en-us/fsharp/default.aspx>

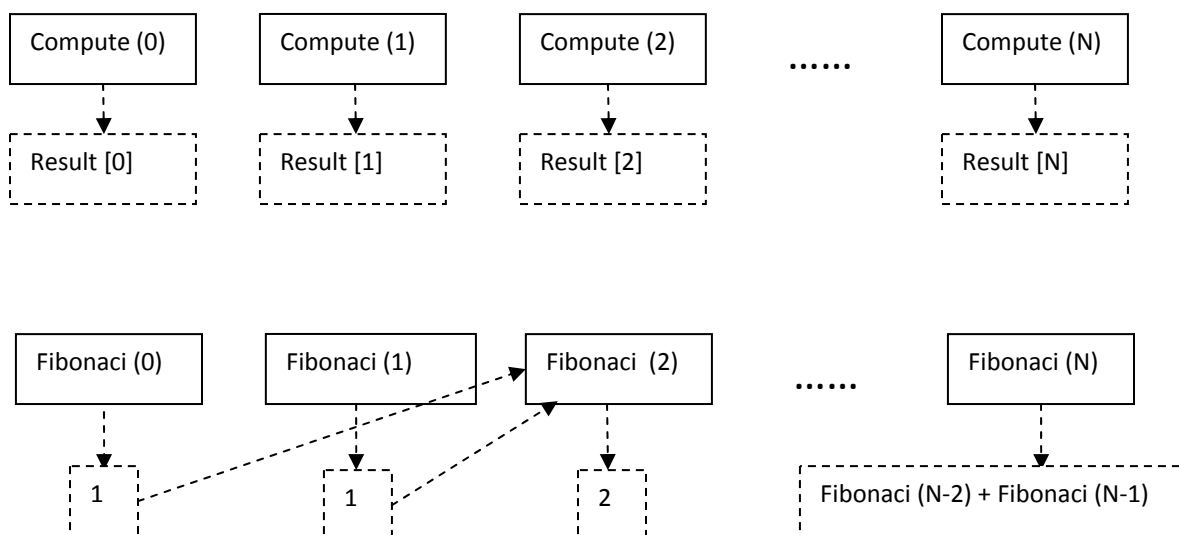
System.Threading.Tasks.Task type represents a task object. A task object is a unit of work in the parallel processing context. It is independently scheduled to run on a processor (general term for core, or processor). This is the basis of expressing task parallelism.

The Create method of Task allows one to create an instance of a Task type that is also associated with a code body that will be executed when this task is associated with a processor. Such association is made via Thread type which is how underlying operating system allocates process/threads to processors.

As a task instance often needs synchronization with other such task instances methods such as Wait and WaitAll are available for Task type. To implement a simple fork/join semantics one can use –

```
Task t1 = Task.Create(delegate { A(); });
Task t2 = Task.Create(delegate { B(); });
Task t3 = Task.Create(delegate { C(); });
Task.WaitAll(t1, t2, t3);
```

It is evident that the task type provides a direct access to the distribution of computational work in a system. It is lower level to the earlier loop parallelization methods.



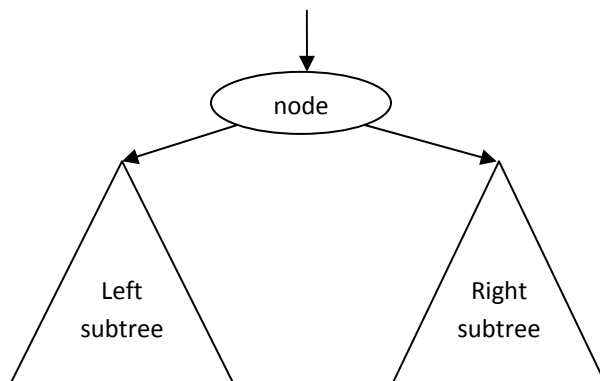
Consider the computation of the Fibonacci numbers where the N-th Fibonacci number is given by the sum of the previous two. The functions Fibonacci (i) depends upon the functions Fibonacci (i-1) and Fibonacci (i-2).

The dependency may be expressed as a general tree structure as follows, where “node” corresponds to the final computation and each tree, left and right corresponds to a recursive definition of the structure itself where the “node” is replaced by the corresponding two sub-computations. In case of the Fibonacci

<sup>4</sup> Running Queries on Multi-core processors <http://msdn.microsoft.com/en-us/magazine/cc163329.aspx>



calculation, node is  $\text{Fibonacci}(N)$  and the left and right subtrees corresponds to  $\text{Fibonacci}(N-2)$  and  $\text{Fibonacci}(N-1)$  respectively.



The structure may be defined and evaluated serially as follows:

```

class Tree<T>
{
    public T Data;
    public Tree<T> Left, Right;
    ...
}
  
```

In C#, iterating over this Tree sequentially might look something like the following:

```

static void WalkTree<T>(Tree<T> tree, Action<T> func)
{
    if (tree == null) return;
    WalkTree(tree.Left, func);
    WalkTree(tree.Right, func);
    func(tree.Data);
}
  
```

To parallelize this computation one may use `Parallel.Invoke` as follows:

```

static void WalkTree<T>(Tree<T> tree, Action<T> func)
{
    if (tree == null) return;
    Parallel.Invoke(
        () => WalkTree(tree.Left, func) ,
        () => WalkTree(tree.Right, func) ,
        () => func(tree.Data));
}
  
```

Observe the `Parallel.Invoke` method takes several delegates and initiates tasks for each independently. The synchronization occurs via the return value mechanism of the called functions. Also, the parallelism is expressed in terms of dividing the entire computation in to tasks that run concurrently. Since,

WalkTree is called recursively; three tasks are generated each time it is called. This amounts to a large number of tasks being used. Tasks are mapped to physical processors via threads and too many tasks may cause excessive demand for threads and lead to resource contention. This is a key lesson in parallel processing and should be covered in details.

Finer control for task parallelism is implemented via the Task type. The concept of task is similar to a thread, however, at a higher abstraction level. It has its own local variables and environment. This is defined via constructors that can take parameters and a delegate for the method to execute. One can use lambda functions and anonymous delegates from C# 3.0. Wait methods are available to synchronize among tasks. Common semantics are available. For details see [].

#### Asynchronous task parallelism

Future<T> type derived from Task type provides a return value. This happens in an asynchronous manner. The entire mechanism of setting up callback and retrieval of result is hidden simplifying adoption and use.

Consider the example of counting all of the nodes in a large tree. Sequentially, this might be implemented as:

```
int CountNodes(Tree<int> node)
{
    if (node == null) return 0;
    return 1 + CountNodes(node.Left) + CountNodes(node.Right);
}
```

With Future<T>, this code can be parallelized as follows:

```
int CountNodes(Tree<int> node)
{
    if (node == null) return 0;
    var left = Future.Create(() => CountNodes(node.Left));
    int right = CountNodes(node.Right);
    return 1 + left.Value + right;
}
```

Comparing the asynchronous approach with the one with Parallel.Invoke or using Task directly one can see the benefit of the former quite easily. Note that unless the Value of a Future task type is retrieved the task is not started at all. This limits the number of tasks generated in the program and is more efficient in terms of implementation than the synchronous method given earlier.

#### Coordination structures

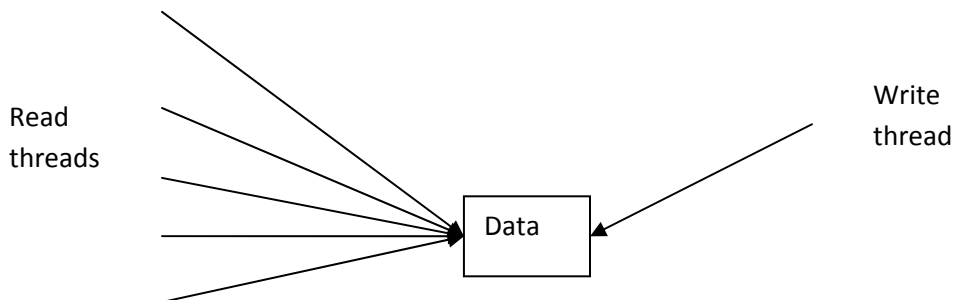
Coordination among multiple threads traditionally is done via control of interaction to avoid race condition. A race happens when the relative order of execution of threads result in wrong result. The goal in synchronization is to ensure this is avoided.

Methods used are locking, signaling and interlocked operations. Locking gives control of a resource to a thread at a time, or to a specified number of threads. The C# Lock statement is implemented using the Enter and Exit method of the Monitor class. It uses try...catch...finally to ensure the lock is released.

Although this form of coordination is essential it does not guarantee starvation, deadlock, fairness etc []. So, many powerful schemes are devised. For example, Monitor class provides TryEnter method that may block a thread for a specified interval and allowing detection of possible deadlock. The Wait method gives up control by a thread in critical section until resource is available, helping fairness and avoiding livelock. Mutex object may also be used for exclusive access to a resource. A thread calls the WaitOne method of a mutex to request ownership. The state of a mutex is signaled if no thread owns it.

Semaphores and reader-write locks are used for non-exclusive locking mechanism where a limited number of threads may be allowed to use a resource. Other mechanisms include Interlocked class, signaling via Join, use of WaitHandle and EventWaitHandles.

The coordination problem or pattern associated with the above synchronization primitives is well illustrated by the readers-writes problem []. Multiple threads read a resource concurrently, but require a thread to wait for an exclusive lock in order to write to the resource.



High level constructs such as thread-safe collections, more sophisticated locking primitives, data structures to facilitate work exchange, and types that control how variables are initialized are part of the .NET 4.0 parallel library. This considerably reduces the pain of developers in implementing correct and efficient coordination schemes.

The following table lists these higher level coordination structures. Counters are used to control thread execution. Threads perform decrement on counters and wait until it becomes zero. The decrement operation on such a counter is atomic and thread-safe (only one thread can get hold of such a counter and change its value at a time atomically). It also has an increment method (also atomic).

**Table 1: High level thread-safe constructs**

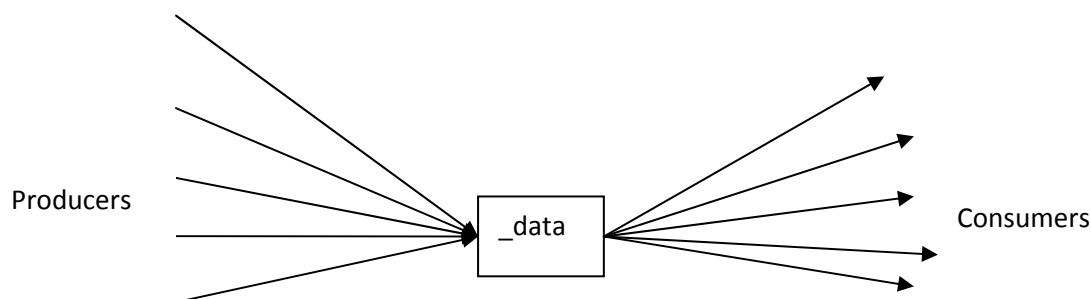
counters	CountdownEvent	ManualResetEventSlim	
locks	SemaphoreSlim	SpinLock	

Collections (namespace)	BlockingCollection<T>	ConcurrentQueue<T>	ConcurrentStack<T>
Lazy data structure	LazyInit<T>	WriteOnce<T>	

LazyInit<T> is a commonly-used tactic for delaying data initialization until the data is actually needed.

The high level coordination structure elevates the synchronization issue to higher level of abstraction that are more natural conceptually to sequential programmers while being in reality a good parallel implementation.

Consider the famous producer-consumer problem in which producers produces at a rate not necessary same as the rate of consumption by consumer. An intermediary collection structure may act as a buffer as the diagram show below.



The data structure for the buffer (`_data`) that holds strings may be expressed as follows.

```
private BlockingCollection<string> _data = new BlockingCollection<string>();
```

This could also be done by explicitly providing the underlying collection to be used:

```
private BlockingCollection<string> _data =
    new BlockingCollection<string>(new ConcurrentQueue<string>());
```

In the context of a producer-consumer problem described above, one or more producer threads can now add data to the queue:

```
private void Producer()
{
    while(true)
    {
        string s = ...;
        _data.Add(s);
    }
}
```

While one or more consumer threads are removing data from the queue, blocking as necessary until data is available:

```
private void Consumer()
{
    while(true)
    {
        string s = _data.Remove();
        UseString(s);
    }
}
```

Such a consumer loop can be made simpler by taking advantage of `BlockingCollection<T>`'s `GetConsumingEnumerable` method, which generates an `IEnumerable<T>` that removes the next element from the collection on each call to `IEnumerable<T>.MoveNext`. This allows for a `BlockingCollection<T>` to be consumed in standard constructs like a `foreach` loop:

```
private void Consumer()
{
    foreach(var s in _data.GetConsumingEnumerable())
    {
        UseString(s);
    }
}
```

It could even be used in a PLINQ query:

```
private void Consumer()
{
    _data.GetConsumingEnumerable().AsParallel().Where(...).Select(...).ForAll(s
=>
    {
        UseString(s);
    });
}
```

`BlockingCollection<T>` acts as a wrapper around any concurrent collection that implements the `System.Threading.Collections.IConcurrentCollection<T>` interface, providing blocking and bounding capabilities on top of such a collection. Both the `ConcurrentStack<T>` and `ConcurrentQueue<T>` types implement `IConcurrentCollection<T>`, allowing them to be used with `BlockingCollection<T>`, but custom implementations of `IConcurrentCollection<T>` can also be used.

As is illustrated above, a high level buffer simplifies implementing the coordination scheme in comparison to conventional low level primitives. Also, this help in hiding much of the complexities of implementing such buffers and keeps the functionality close to what a sequential program developer can easily work with.

## Handling Exceptions

In the parallel extension library all exceptions from different threads are aggregated into a `AggregateException` object. The original exceptions are accessible through the `InnerException` property of this object. This is a catchall approach and ensures that a developer can be made aware of all relevant exceptions and that all errors are properly bubbled up. Each exception has a valid stack trace.

Examples of scenarios where `AggregateExceptions` are thrown are from `Parallel` class – `Parallel.For`, `Parallel.ForEach` or `Parallel.Invoke` region; `Task` class – all exceptions thrown during the execution of all tasks will be at the tasks `Wait` method. The exceptions are also available from the `Task`'s exception property. (is the latter `Aggregate`?). (need example); for `Future<T>` class – exceptions will be rethrown both from its `Wait` method and from its `Value` property; `PLINQ` – exceptions will occur when the query is executed – `ForAll()`, `ToList()`, `ToDictionary()`, `ToLookup()`, and `MoveNext()` on result of calling `GetEnumerator()` such as in a `foreach` loop.

Thread affinity needs to be honored for UI and COM based interoperation scenarios. This is an advanced issue and should be only presented in the context of interoperability.

### **Service oriented approach**

Distributed memory model for parallel computing is based on message passing. This model has no shared memory and any resource sharing is via messages. The .NET library in the Microsoft Robotics Studio contains the `Concurrency and Coordination Runtime (CCR)` and the `Decentralized Software Services (DSS)` library to offer a loosely connected services oriented concurrency platform.

Although initially built with highly disperse concurrency requirement of a robotics computing environment the `CCR` offers basic concurrency, asynchronous message passing loosely connected computing model that inherently offers a general parallel programming framework. The parallel processing components are easily available.

We can look at software components as self-consistent services with known interfaces. A service can interact with another via service ports. This basic model is supported on one machine via `CCR` and across multiple machines via `DSS`. `CCR` provides mechanisms to define ports and services along with underlying asynchronous processing of messages that flow through the ports. As a message is posted to a message port of a service it is processed on a concurrently running thread.

Parallelism is inherent in the model. Any number of items in a port is processed on different threads. The model does not need any explicit locking or synchronization as all dependencies are incorporated via the ports. The `DSS` extends the model to multiple machines where inter node message communication is done via HTTP based protocol called `DSSP`.

The model is similar to the well know dataflow model of parallel computing []. The Microsoft Robotics Studio also consists of a graphic lingual called `Visual Programming Language` that reflects the basic dataflow nature of the model.

A program that defines a basic service class along with a Create method to create instances, a set of ports, and initialization of message handlers using a receiving task configured via a scheduler called Arbiter is given below.

```

/// PortSet that accepts items of int, string, double
public class CcrConsolePort : PortSet<int, string, double>
{
}

/// Simple example of a CCR component that uses a PortSet to abstract
public class CcrConsoleService
{
    CcrConsolePort _mainPort;
    DispatcherQueue _taskQueue;

    public static CcrConsolePort Create(DispatcherQueue taskQueue)
    {
        var console = new CcrConsoleService(taskQueue);
        console.Initialize();
        return console._mainPort;
    }

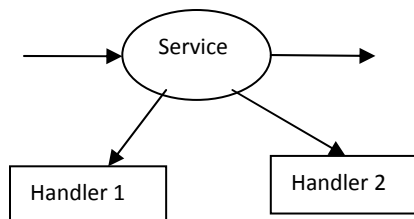
    private CcrConsoleService(DispatcherQueue taskQueue)
    {
        // create PortSet instance used by external callers to post items
        _mainPort = new CcrConsolePort();
        // cache dispatcher queue used to schedule tasks
        _taskQueue = taskQueue;
    }

    private void Initialize()
    {
        // Activate three persisted receivers (single item arbiters)
        // that will run concurrently to each other,
        // one for each item/message type
        Arbiter.Activate(_taskQueue,
            Arbiter.Receive<int>(true, _mainPort, IntWriteLineHandler),
            Arbiter.Receive<string>(true, _mainPort, StringWriteLineHandler),
            Arbiter.Receive<double>(true, _mainPort, DoubleWriteLineHandler)
        );
    }

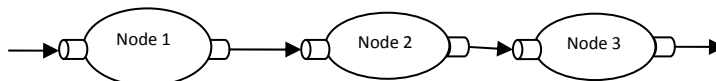
    void IntWriteLineHandler(int item)
    {
        Console.WriteLine("Received integer:" + item);
    }
    void StringWriteLineHandler(string item)
    {
        Console.WriteLine("Received string:" + item);
    }
    void DoubleWriteLineHandler(double item)
    {
        Console.WriteLine("Received double:" + item);
    }
}

```

Note that concurrency is built in via the Arbiter which will activate a receiver task for any item posted on the port of the service. The task or handle of the message is scheduled via a DispatcherQueue and corresponding Dispatcher and optimizes the underlying cores of the hardware the program run on.



A program is given by set of service instances and ports instances connecting them. A service encapsulates a component. A sequence of service instance that processes output from the previous element may be shown as



Note that the model does not constrain the concurrent processing of the messages on the port. This is the typical pipeline pattern.

The CCR builds on three types of elements. These are CCR Ports and PortSets, coordination primitives called arbiters, and the Dispatcher and DispatcherQueue.

The Port class is a first in first out (FIFO) queue of items which is a Common Language Runtime type and a corresponding set of receivers that is guarded by arbiters. Arbiters execute user code, often a delegate to some method when some conditions are met. Arbiters can be nested to implement extended coordination logic. The Dispatcher and DispatcherQueue isolates scheduling and load balancing from the rest of the implementation. CCR avoids a single process wide execution resource as in CLR thread pool and allows the programmer to have multiple, completely isolated pools of OS threads that abstracts the notion of threading behind them. Multiple queues per dispatcher allow for a fair scheduling policy.

Adding an item to the port is an asynchronous operation. The interaction between components may take place by one posting an item in a port of another component in a non-blocking manner. This is done via Post() method.

```
Port<int> portInt = new Port<int>();
```

```
portInt.Post(10);
```

The second component can process such an item based on condition as implemented via arbiters. Such operation may either be passive or active. In the first case no tasks are scheduled when items are posted. Example is the Test() method on a port to detect presence of an item in it. Details are found in the user manual [].



The PortSet class allows for enumeration of all the port instances and item types it supports. The generic PortSet also provides convenient methods that automatically invoke the correct Port<> instance plus implicit conversion operations that can cast a PortSet<> instance to a Port<> instance automatically.

Arbiters implement a set of coordination logics. For example, it can create a task, a choice among two or more operations, a receiver, interleave, join of messages etc. It is possible to compose arbitrary coordination logic using them.

A simple example of using an arbiter type is given below:

```
// create a simple service listening on a port
ServicePort servicePort = SimpleService.Create(_taskQueue);

// create request
GetState get = new GetState();

// post request
servicePort.Post(get);

Arbiter.Activate(_taskQueue,
    get.ResponsePort.Choice(
        s => Console.WriteLine(s), // delegate for success
        ex => Console.WriteLine(ex) // delegate for failure
    ));
```

The get message is posted on the input port. The Activate method schedules a task on \_taskQueue which listens to the ResponsePort associated with the get message (a message has a operation, response port and a body) via a Choice function and if the message type is that of s prints the value of s, or if it is of type ex, prints the value of ex.

An extensive set of types are available to develop parallel programs using this model. The Iterators is used for nesting asynchronous calls while being very close to the commonly understood iteration types. A sort program on a linear array may be designed with identical service instance wrapped in an iterator.

The CCR addresses failure handling with two approaches. One is the explicit or local failure handling using the **Choice** and **MultipleItemGather** arbiters. Combined with iterator support they provide a type safe, robust way to deal with failure since they force the programmer to deal with the success and failure case in two different methods and then also have a common continuation. The other one is an implicit or distributed failure handling, referred to as Causalities that allows for nesting and extends across multiple asynchronous operations. It shares in common with transactions the notion of a logical context or grouping of operations and extends it for a concurrent asynchronous environment. This mechanism can also be extended across machine boundaries.

## MATLAB-Based Demo Program for Discrete-Time Convolution

Gordana Jovanovic Dolecek<sup>1,2</sup> and fred harris<sup>2</sup>

<sup>1</sup>Department of Electronics Institute INAOE, Puebla, Mexico

E-mail: gordana@inaoep.mx

<sup>2</sup>Department of Electrical Engineering, SDSU San Diego, USA

E-mail: fred.harris@sdsu.edu

### 1. Introduction

Though the field of engineering has changed dramatically in the last 20 years, the teaching engineering has changed relatively little<sup>1</sup>. Many of the engineering lecture courses are taught using a traditional method i.e. only with the support of a blackboard or transparencies. The major disadvantages of traditional teaching methods are that students usually have to choose between taking notes and listening to the lecturer. As a result, most of the learning in traditional teaching is individual, since the students in the classrooms are taking notes or listening instead of participating<sup>2</sup>. Consequently, many students in conventional classrooms develop little confidence in their own ability to learn<sup>3</sup>.

Demonstrations that illustrate concepts with visual aids are one of the important tools in the field of engineering education. They help students connect theory with practice; they realize how theory and systems are connected<sup>4</sup>. Students learn better, remember longer and are better able to identify the appropriate concepts to solve new problems when they learn by addressing concrete problems and actively participate in exploration and pursuit of knowledge<sup>3</sup>.

The availability of personal computers (PCs), their increasing calculation power, and their enhanced graphical possibilities enable teachers to take the advantage of the pedagogical possibilities afforded by new technologies<sup>5</sup>. Computer-aided learning has become extremely popular and its use in classroom can be very helpful by adding more analytical capabilities in all engineering areas<sup>6</sup>. It can be applied in the aspects of teaching, learning, validation, and research in engineering education<sup>4</sup>. Besides, it is beneficial especially in terms of saving time and efforts for both teaching and learning in the educational process<sup>4</sup>.

Our experience at the National Institute INAOE<sup>7-9</sup>, shows that the development and usage of software tools represent an effective teaching approach and increase students' learning. Such software tools must be reliable, student-friendly and with no requirements for the corresponding programming knowledge. In pursuance of this goal we developed the educational demo program to support the theory provided in basic courses in which the fundamentals of Digital Signal Processing are taught. The next section provides a brief description of the program. Section 3 shows the demo program in details. Last section is dedicated to the demo program evaluation issue.

### 2. Description of the program

The package was implemented in MATLAB. We choose MATLAB because MATLAB along with the accompanying toolboxes is the tool of choice for most educational and research purposes<sup>10</sup>. We used the MATLAB tool `makeshow` which allows the student to create her/his

own interactive slideshows without building her/his own graphic interface. There are two windows in each slide. We used the upper windows for specific explanations as in Slide 1, Fig.1, or for graphics, as in Slide 2 (Section 3). The bottom window is used for general explanations as in Slide 2, or for the explanations of the upper graphics, as in Slide 3 (Section 3). The order of the slide and the command buttons are on the right side of each slide.

The student can change the slides automatically using the option `AutoPlay`. In this case the student may use the button `Stop` to stop the presentation and later hit `Continue` to continue it. The student can also choose the option to change slides manually with the mouse, by clicking `Next` to go forward or `Prev`, to go backward. The buttons `Reset` and `Close` are used to reset the demos and exit the program, respectively.

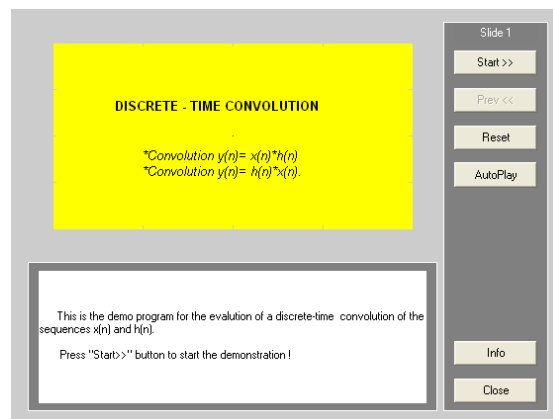


Fig.1. First slide.

## 2. Discrete-time convolution

The Discrete-time convolution is one of the most important operations in a discrete-time signal analysis<sup>11</sup>. The operation relates the output sequence  $y(n)$  of an linear-time invariant (LTI) system, with the input sequence  $x(n)$  and the unit sample sequence  $h(n)$ , as shown in Fig.2.

$$y(n) = \sum_k x(k)h(n-k) = x(n) * h(n), \quad (1)$$

where the asterisk "\*" indicates the convolution operation.

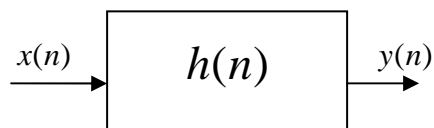
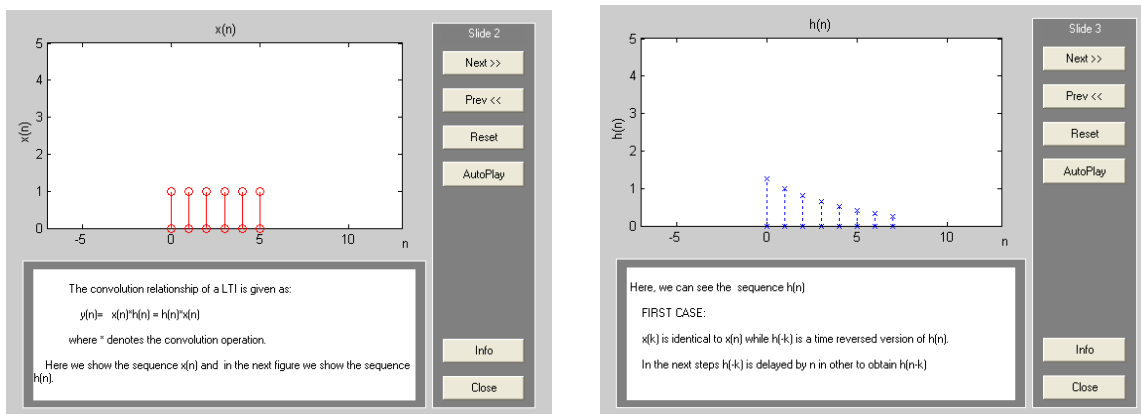


Fig.2. LTI Discrete-time system.

The input and impulse response sequences are given in Fig.3. The sequence  $h(k)$  is time reversed about the zero index to become  $h(-k)$  as shown in Fig.4. In the following steps  $h(-k)$  is shifted to the right by the index  $n$  to form the offset sequence  $h(n-k)$ . Figure 4 shows the starting position where  $n=0$ . The sequence  $x(k)$  and  $h(n-k)$  are multiplied, as shown in the upper figure. The result of the multiplication is the value of the output sequence at the index  $n$ , as shown in the

bottom figure. Figure 5 demonstrates all steps from  $n=1$  until  $n=12$ . The final result is shown in Fig.5.



a. Input sequence.

B. Impulse response sequence.

Fig.3. Input and unit sample response sequences.

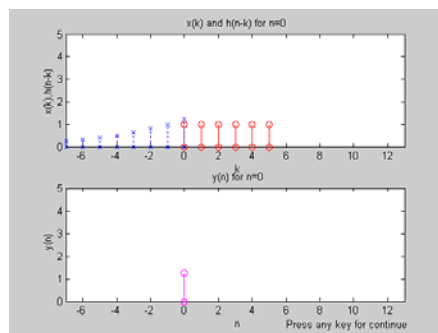
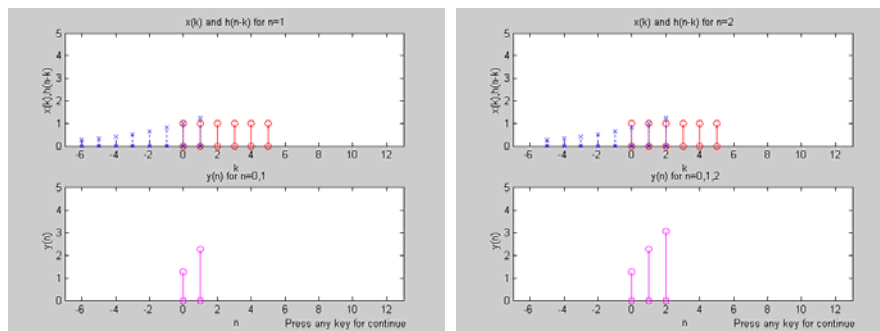
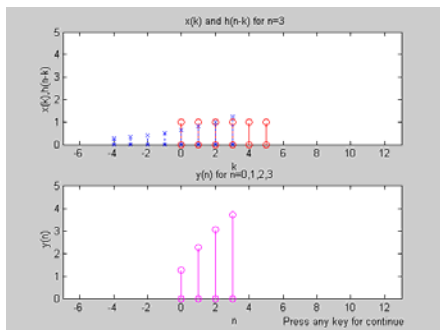


Fig. 4.  $n=0$ .

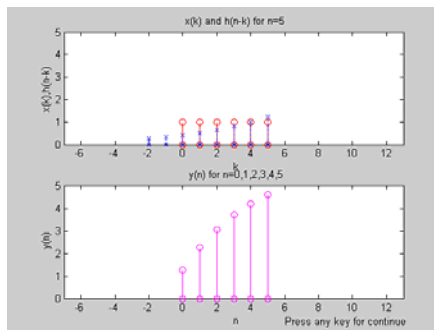


$n=1$ .

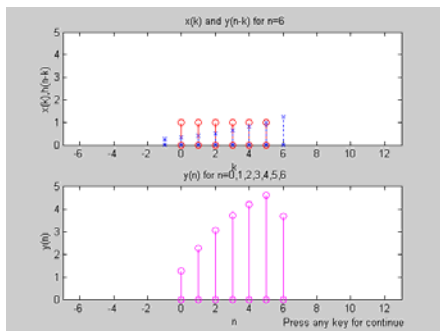
$n=2$ .



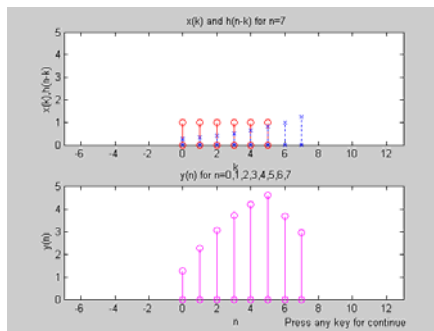
$n=3.$



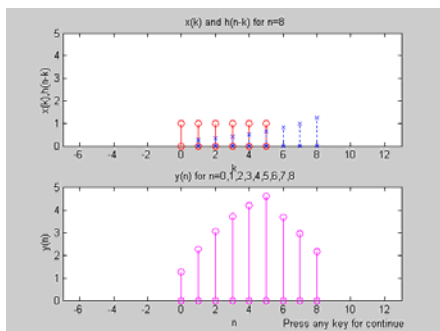
$n=5.$



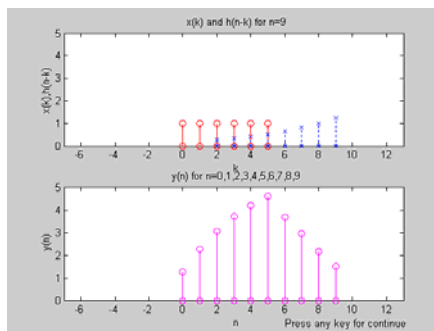
$n=6.$



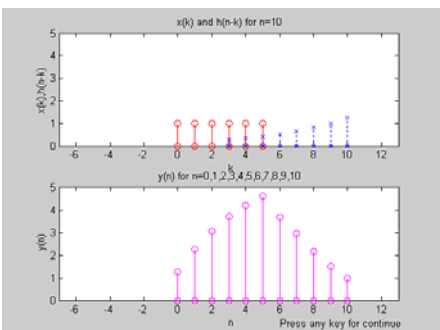
$n=7.$



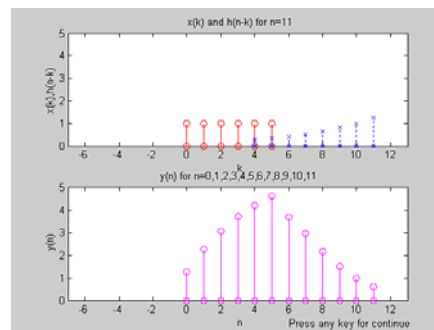
$n=8.$



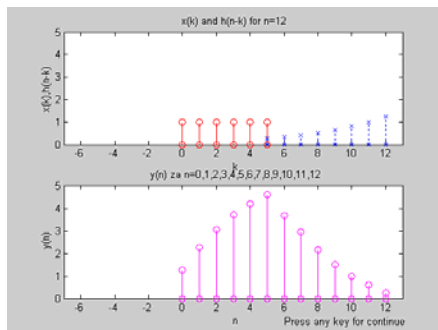
$n=9.$



$n=10.$



$n=11.$



n=12.

Fig.4. Convolution step by step.

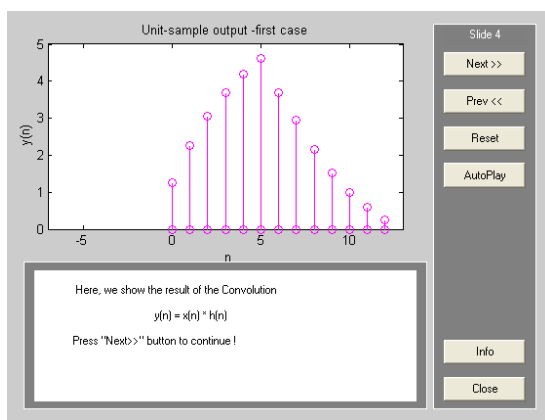


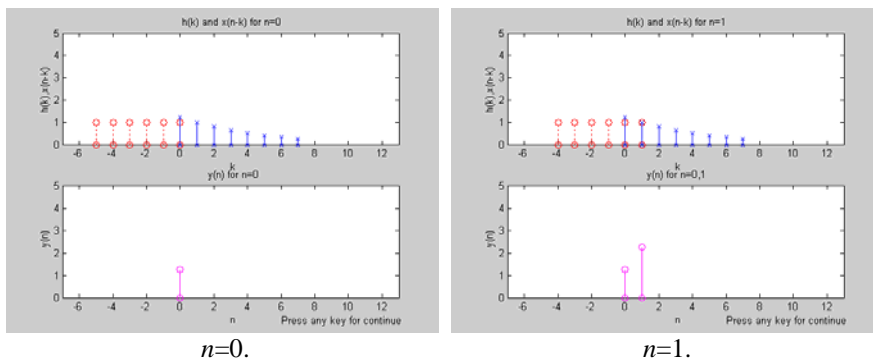
Fig.5.The final result.

#### 4. Commutative characteristic

In following is demonstrated that the convolution is commutative operation, i.e.

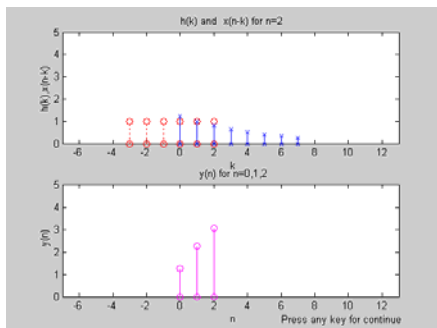
$$y(n) = \sum_k x(k)h(n-k) = \sum_k h(k)x(n-k) . \tag{2}$$

Figure 6 shows all steps from n=0 until n=12, and Fig.7 shows the final result.

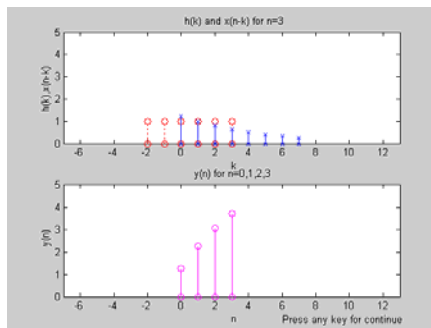


n=0.

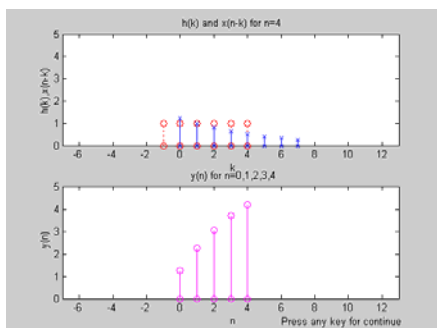
n=1.



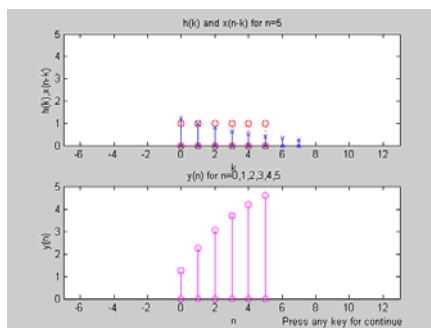
$n=2.$



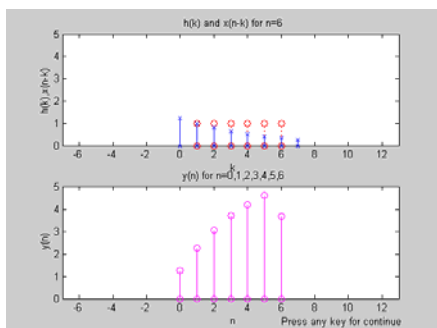
$n=3.$



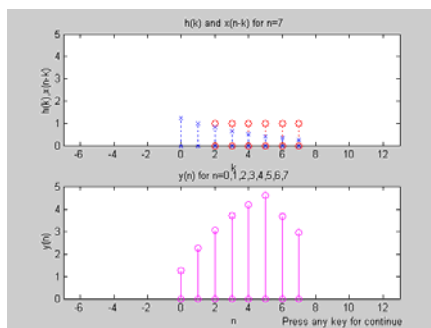
$n=4.$



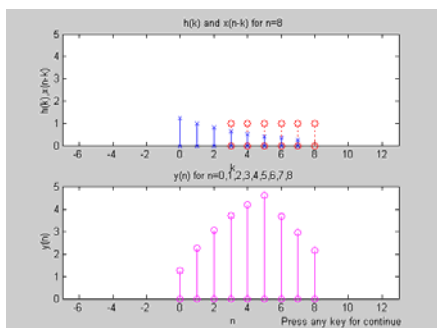
$n=5.$



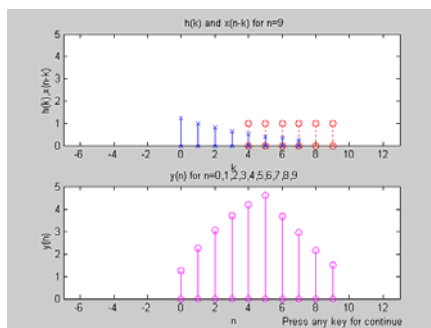
$n=6.$



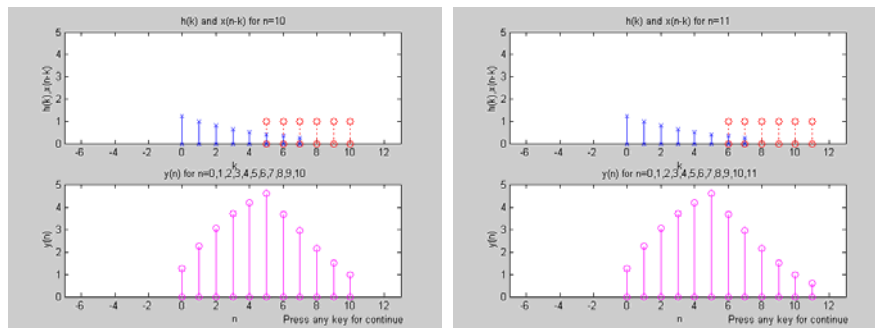
$n=7.$



$n=8.$

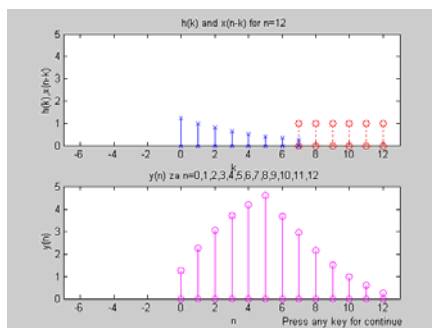


$n=9.$



$n=10.$

$n=11.$



$n=12.$

Fig.6. Convolution: Step by Step.

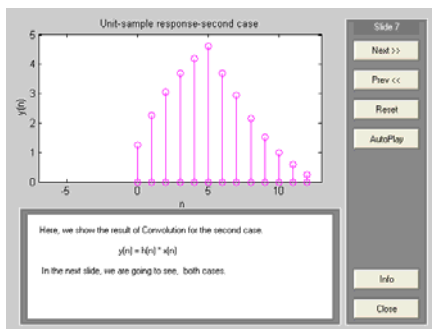


Fig.7. Final result.

Finally Fig.8 confirms that results from Fig.4 are equal to the results from Fig. 6, i.e. that the convolution is a commutative operation.



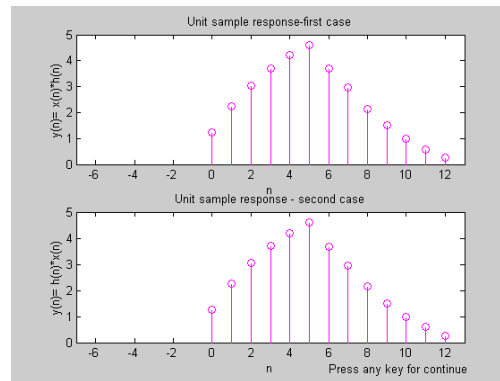


Fig.8. Comparison.

## 5. Evaluation

We considered that is very important to get information from students about to the usefulness of the software in the teaching-learning process. To this end we developed a suitable tool to evaluate quality of the program of the software in the teaching-learning process. The set of questions attempted to test the program design aspects and usefulness of the software for teaching convolution was generated. All questions in the form are rated with marks from 1 to 4 with the latter being the highest mark.

### Evaluation form:

1. Justification for the computer use in teaching DSP. (1=unjustified; 4=absolutely justified).
2. Contribution to study of DSP by demo program use. (1=irrelevant; 4= very effective).
3. Clarity of explanations and features of demo. (1=confusing; 4=absolutely clear).
4. Did this demo help you to understand better the Convolution? (1=NO; 4=Absolutely YES).
5. Did this demo help you to understand better the Commutative characteristic of Convolution? (1=NO; 4=Absolutely YES).
6. Special knowledge or programming skills required. (1=excessive; 4=null).
7. Ease of operation. (1=complex; 4= very easy).
8. Flexibility & Repeatability (Possibility to come back to previous slide/slides and repeat it/them many times). (1=unnecessary; 4=very useful).
9. General quality of presentation (figures, resolution, visibility, etc). (1=pure; 4=excellent).

The test is applied for the group of students enrolled in basic course of DSP. The rating scheme in terms of the average marks is given in plot in Fig.9. The results clearly demonstrated that students liked this way of teaching and they find this demo very useful for understanding the convolution operation. They especially highly rated the features of the program like flexibility and repeatability, ease of operation, and no programming skills required to run the program.

## 5. Concluding remarks

The paper presents the demo program for the discrete time convolution. All steps of the convolution are presented. It is also shown that the convolution is a commutative operation.

The package is implemented in MATLAB and uses graphical tool `make show`, available in MATLAB. The demo is composed of slides that contain the plots of the corresponding signals and a short explanation. The demo can run automatically or manually, and each slide can be

repeated many times. In that way the student can compare the actual result with any previous one.

This demo program is utilized for teaching the basic course on Digital Signal Processing. By their opinions obtained through the evaluation test, this program helped them to understand and remember this important operation.

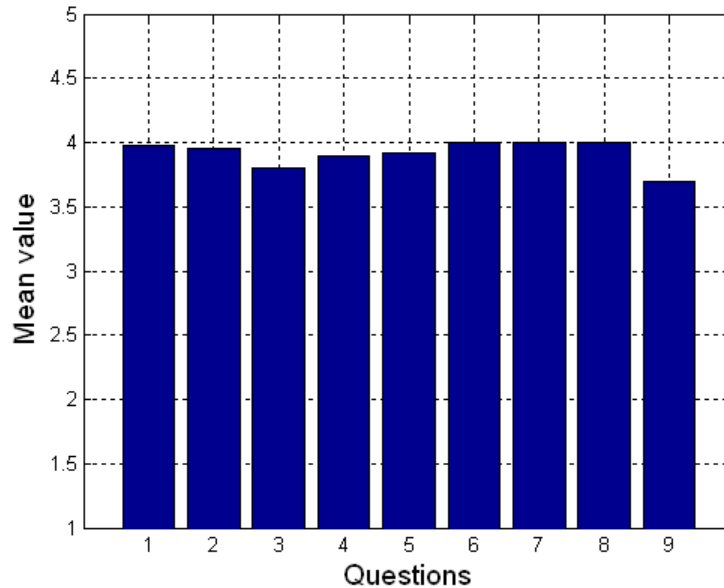


Fig. 9. Rating scheme.

## Acknowledgement

This work was supported in part by the CONACYT under Grant No. 91013.

## References

1. T. C. Hutchinson, F. Kuester, ,, Hardware Architecture for a Visualization Classroom: VizClass, 2004 Wiley Periodicals, Inc. *Comput appl Eng Educ* 12:232-241.
2. Fuller D.A. and Moreno A.F. (2004). Experimenting With a Computer-Mediated Collaborative Interaction Model to Support Engineering Courses, *Computer Applications in Engineering Education*, 12 (3), 175-187.
3. Li, S. G. and Lie, Q.(2004). Interactive Groundwater (IGW): An Innovative Digital Laboratory for Groundwater Education and Research, *Computer Applications in Engineering Education*, 11 (4), 179-203.
4. Fu, T.T. (2003). Applications of Computer Simulation in Mechanism Teaching, *Computer Applications in Engineering Education*, 11 (3), 156-165.
5. Riera V. J., Gimenez M. H., and Monsoriu J. A. (2002). Contribution of Digital Simulation in Visualizing Physics Processes, *Computer Applications in Engineering Education*, 10 (1), 45-49.

6. Fernandez A. J. and Sanchez J. M. (2004). CGRAPHIC: Educational Software for Learning the Foundations of Programming, *Computer Applications in Engineering Education*, 11 (4), 167-179.
7. Jovanovic Dolecek G. (1997). RANDEMO: Educational Software for Random Signal Analysis, *Computer Applications in Engineering Education*, 5 (2), 93-99.
8. Jovanovic Dolecek G. and Champac V. (2000). CGTDEMO- Educational Software for the Central Limit Theorem, *ACM Press, SIGCSE Bulletin*, 32 (2), 46-48.
9. Jovanovic Dolecek G., Madrigal J. M., Ibarra-Manzano O. (2000). MuDSPDEMO- Demo Package for Multirate Digital Signal Processing, *Computer Applications in Engineering Education*, 8 (2), 132-138.
10. Kim A. S., Park C., and Park S. H.(2003). Development of web-based Engineering Numerical Software (WENS) Using MATLAB: Applications to Linear Algebra, *Computer Applications in Engineering Education*, 11 (2), 67-75.
11. Mitra, S. K. (2005). *Digital Signal Processing*, New York. 3 edition, Mc. Graw Hill.

**Gordana Jovanovic Dolecek** received a BS degree from the Department of Electrical Engineering, University of Sarajevo, an MSc degree from University of Belgrade, and a PhD degree from the Faculty of Electrical Engineering, University of Sarajevo. She was professor at the Faculty of Electrical Engineering, University of Sarajevo until 1993, and 1993-1995 she was with the Institute Mihailo Pupin, Belgrade. In 1995 she joined Institute INAOE, Department for Electronics, Puebla, Mexico, where she works as a professor and researcher. During 2001-2002 and 2006 she was with Department of Electrical & Computer Engineering, University of California, Santa Barbara, as visiting researcher. She is currently with San Diego State University as visiting researcher on a sabbatical leave. She is the author of three books, editor of one book, and author of more than 200 papers. Her research interests include digital signal processing and digital communications. She is a Senior member of IEEE, the member of Mexican Academy of Science, and the member of National Researcher System (SNI) Mexico.

**fred harris** is professor of Electrical and Computer Engineering at San Diego State University, where he holds the CUBIC Signal Processing Chair of the Communication Systems and Signal Processing Institute. He has extensive practical experience applying his skills to satellite and cable TV communication systems, wire-line and wireless modems, underwater acoustics, advanced radar and high performance laboratory instrumentation. He holds several patents on digital receiver and DSP technology, lectures on DSP worldwide, and consults for organizations requiring high performance DSP systems including the SPAWAR, Lockheed, Cubic, Hughes, Rockwell, Northrop Grumman, SAIC, GDE, and Motorola. He is has published over 160 papers and has contributed to a number of books on DSP. In 1990 and 1991 he was the Technical and then the General Chair of the Asilomar Conference on Signals, Systems, and Computers which meets annually in Pacific Grove, California. He is Editor of *Signal Processing*, Journal of Elsevier. He is the author of the Prentice-Hall textbook "Multirate Signal Processing for Communication Systems" and is a Life Fellow of the IEEE.

## **Expanding Engineering Education through Undergraduate Research Experience in Micro-Robotic Drug Delivery**

Eniko T. Enikov<sup>1</sup>, Malcolm T. Gibson<sup>2</sup>

Advanced Micro and Nano Systems Laboratory, Department of Aerospace and Mechanical Engineering, The University of Arizona. <sup>1</sup>Principal Investigator, <sup>2</sup>Undergraduate Student

### *Abstract*

This paper examines the use of MEMS research in bio-medical micro-robotic drug delivery as an education vehicle for expanding the effectiveness of undergraduate engineering education in order to meet advancing challenges of the future. Micro-robotic drug delivery is a diverse area of research with emerging applications in intraocular surgery and cancer treatments. This research requires integration of engineering sciences such as bio-systems, fluid mechanics, thermodynamics, chemistry, material sciences, and more. This allows various engineering disciplines to utilize their classroom knowledge in direct research with real, innovative applications in technology. This method of complimenting engineering education with curricula-related research has shown improvement in engineering accomplishment and learning that is advantageous to the future success of undergraduate engineering education.

### Introduction

Engineering focuses on the development and discovery of important resources such as energy, materials, and information in order to provide tools and technology in service of advancing human civilization. Consequently, engineering activity has a global impact due to the international utilization of innovative discovery. For this reason, engineering education has the objective of presenting not only the engineering sciences but also how to apply them to direct applications in a manner that is judicious and conscience of societal and environmental impact<sup>1</sup>. In order to meet the future challenges of an advancing engineering industry, undergraduate education needs to prepare students in a vast spectrum of sciences and technical skills. This requires collaboration between classroom knowledge and laboratory practice. By utilizing the opportunities for undergraduate research projects, students can significantly advance their education by applying first-hand the curricula they are learning in class. This approach allows for a greater understanding of the advanced sciences and an early exposure to the laboratory skills, both technical and practical, utilized by the professional engineering industry.

One way of accomplishing this is through the pursuit of research in microelectromechanical systems (MEMS) and the technologies it encompasses. MEMS research is an innovative research area for undergraduates because it incorporates a diverse range of technical skills in various engineering fields and represents many current and emerging applications in society. With a history of over 30 years, MEMS research has supported the development of technologies such as switches, displays, pressure sensors, accelerometers, gyroscopes, inkjet printer heads, and lab-on-a-chip chemical detection systems. Discoveries such as these have not only inspired the industrial world, but have given rise to interest among academic institutions in incorporating MEMS into their curriculum<sup>2,3</sup>. MEMS research has an

interdisciplinary nature originating from the need to design and integrate electrical, mechanical, optical, and chemical sub-systems into a functional device<sup>1</sup>. This paper focuses on the use of MEMS principles in Micro-Robotic research as an innovative education vehicle to attract top students from various engineering backgrounds and give them the opportunity to expand their education by being actively involved in an exciting research project.

## MEMS Micro-Robotic Research

MEMS research is a broad field with multiple areas of critical development and investigation. It requires a collaborative effort spanned by engineering disciplines such as robotics, automation, ultrasound, fluid dynamics, modeling, kinetics, magnetism, bio-systems, and other curricula as reviewed in table 1. In recent years, MEMS technologies have been integrated into many bio-medical applications. One of these applications is the development of micro-robotic drug delivery systems. The purpose of these systems is to provide a means for wireless, targeted drug delivery to various areas of the human body. These systems are of interest to the medical industry because they could provide less adverse methods for cancer treatment<sup>4</sup>, replace high-risk intraocular micro-surgeries<sup>5</sup>, and provide great improvements in future technologies such as those reviewed by Gilles<sup>6</sup>. The development of these systems requires a collaborative grouping of research in areas such as structural design, assembly, bio-compatibility, encapsulation, steering and guiding, imaging and tracking, insertion and retrieval, and actuation. Consequently, this MEMS research incorporates a diverse range of engineering disciplines. Of these areas, micro-robotic actuation has been one area of undergraduate research success. This aspect of research focuses on the investigation of alternative drug release mechanisms to improve the remote triggering of drug release from the robot structure. Existing methods use diffusion<sup>7</sup> and magnetic modulation as a means for triggered release but have shown disadvantages relating to release time and magnetic interference with emerging steering and guiding systems<sup>8</sup>. For these reasons, ultrasound is being investigated as an alternative actuation mechanism for drug delivering micro-robots. This research project is ideal for undergraduate student research because it involves knowledge and curricula from general chemistry, biology, physics, and core engineering sciences. It also presents an affordable opportunity for innovative research and undergraduate learning experience.

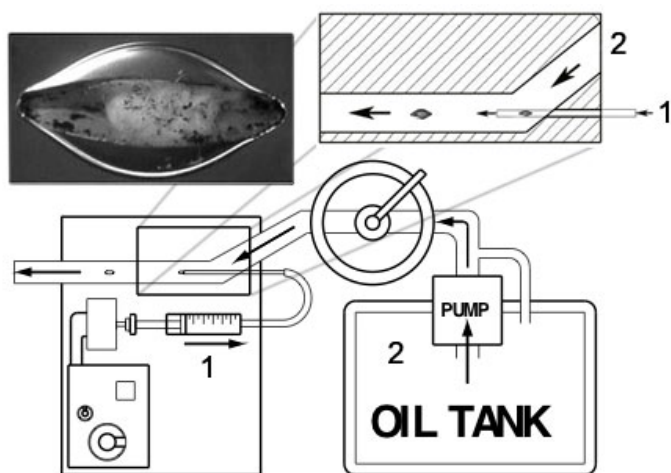


Fig. 1: Micro-robot encapsulation system showing fluid manifold and encapsulated micro-robot. 2 – Continuous Oil Phase. 1 – Sodium Alginate Disperse Phase

Subject/Curriculum	Relation to MEMS Micro-Robotics Research
Intro. Mechanics	Newton's Second Law
Fund. Tech of Chemistry	Kinetics, Beer's law of absorbance. Spectroscopy and concentration measurements.
Intro. Electricity and Magnetism	Magnetic forces and torques, circuit analysis.
Intro. CAD / Graphics	Photomask design, conceptual graphics
Differential Equations	Force derivation and modeling
Elements of Electrical Engr.	Electromagnetics and driving circuits.
Thermodynamics	Diffusion kinetics
Fluid Dynamics	Characterizing flow regimes, motion in low Reynolds number environments.
Instrumentation Lab	Control of B-Field and gradients
Fund. Of Engr. Materials	Bio-polymers: processing/use
Senior Lab	Device testing and analysis
Control Systems	Closed-loop position control

Table 1: MEMS disciplines and applications of engineering curricula.

The technical aspects of this research focus on the development of a bio-compatible surface skin with the purpose of inhibiting drug leakage prior to remote actuation, the mechanisms inducing the drug dispersion, and the measurement and analysis of the release characteristics. The bio-compatible coating materials derive from the protocol reported by Saslawski<sup>9</sup> and are used in a series of chemical soaks to induce the formation of a polymer based outer coating. The method of coating is also an important research area to ensure consistency of release characteristics and uniformity. The most efficient method implements encapsulation by means of a co-fluidic extrusion system (figure 1). This system was designed to disperse Sodium Alginate drug complex into a continuous oil flow via a capillary tip. This method allows the experimenter control of the droplet size and disperse frequency thus making it ideal for encapsulation of various micro-robots and MEMS devices. The development of this system employed many concepts from fluid mechanics and required an in-depth analysis to characterize the performance as a direct result of design parameters. This required an undergraduate researcher to apply fluid mechanical concepts, such as flow regimes, Reynold's numbers, and interfacial tension forces, to an actual design concept. Another aspect of the project focused on bio-compatible chemicals to use in the drug delivery process. Horseradish Peroxidase was chosen as a drug substitute and is contained in the Alginic coating during this extrusion process. The encapsulated micro-robots are then soaked in a 0.1M Calcium Chloride ( $CaCl_2$ ) solution for up to 15 minutes. This salt solution promotes cross-linking with the NaAlg. and creates a drug-containing, durable surface shell surrounding the magnetic robot structure. The robots are then transferred into a polyethylenimine (5% wt.) solution for approximately 4 minutes. During this soak, a protective polymer coating forms and serves to isolate the drug containing sub-layer from the surrounding fluidic environment. The droplets are finally soaked in a Poly-l-lysine (2% wt.) solution where the poly-l-lysine is hypothesized to leak into the  $CaCl_2$ - NaAlg. cross-linking and strengthen it. This aspect of the project utilized various chemistry concepts that govern the underlying principles of the surface skin formation. The undergraduate researcher had to familiarize himself with these concepts in order to understand the formation process and

optimize the relative effects of chemical concentration and soak times on skin formation. After the formation of the protective surface barrier, the droplets are prepared for drug release studies. Visual release results showing the effectiveness of the protective surface skin are shown below in figure 2.

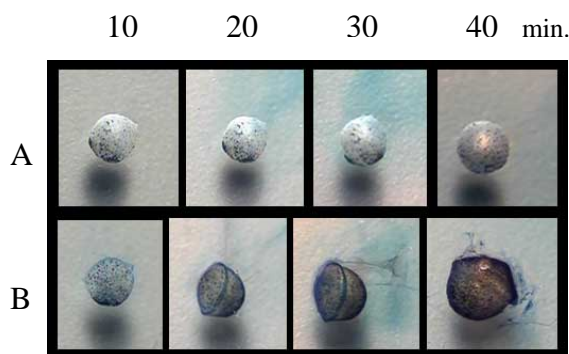


Figure 2: Visual release experiment showing the impact of the protective surface skin on release kinetics. **A** droplets have a protective surface skin while **B** droplets are bare. Drug release is observed by color change in surrounding fluid.

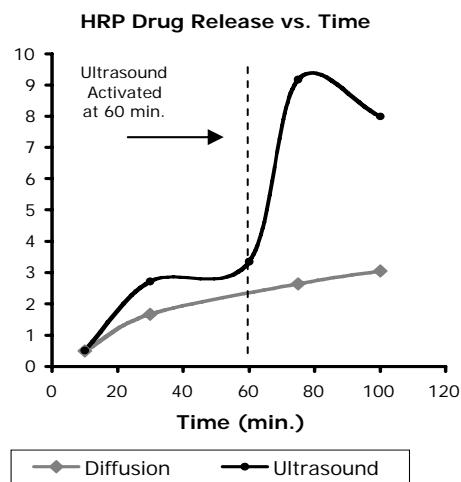


Figure 3: HRP drug release vs. time for both diffusion and ultrasonically stimulated micro-robots.

In order to test ultrasound as a proposed release mechanism for encapsulated micro-robots, undergraduate research assistants faced the task of designing affordable and efficient test experiments. This approach requires undergraduate students to use their scientific knowledge to assess the affordability of research practices and ensure efficient methods of hands-on experimentation. Student research assistants did this by using an ultrasonic bath designed to utilize ultrasonic cavitation as a mechanism for cleaning lab glassware and equipment. They tested the drug release effectiveness by sonicating robot samples for various time intervals and observing the robot behavior and release dynamics. In order to assess the ultrasonic power and effective causes of release, students had to employ research and analysis methods to characterize the results of their experimentation. They used spectrophotometry techniques and a selected chromogenic substrate, Tetramethylbenzidine (TMB), to quantitatively measure the amount of released drug with respect to ultrasound exposure time. This gave students the opportunity to apply common engineering instrumentation methods to discover and report the success of ultrasound as an alternative drug release mechanism for bio-medical micro-robots. The results of ultrasound as an actuation mechanism are shown above in figure 3.

#### Educational Impacts of Undergraduate MEMS Research

This project and other MEMS research areas present many advantages to engineering education and the advancement of learning in undergraduate engineering disciplines. One of these advantages is the heightened understanding of classroom curricula. By applying first-hand the engineering knowledge taught in the classroom, undergraduate students are able to increase their scope of understanding in industry applications and practical laboratory procedures. This not only expands ones understanding but also increases excitement and motivation in the curriculum due its apparent utilization in real, innovative research. This increased excitement

also permeates into the students overall perspective on their engineering education as a whole and serves as a backbone to further engineering accomplishment. Undergraduate involvement in research also gives students an early exposure to laboratory instrumentation and experimental procedures commonly undergone by the engineering industry. This allows students to develop significant technical and practical laboratory skills that are of interest to many engineering employers. It also promotes a clearer understanding of the discovery process and the steps undergone to make an engineering idea become a developed product. Another advantage offered by undergraduate research is the knowledge gained from technical research and reporting. Since research often leads to novel discoveries, undergraduate students are also exposed to the procedures encompassed in technical writing and publicizing new research. This creates a great opportunity for undergraduate students to submit papers to conferences and gives them the potential to be invited to conference proceedings for poster or oral presentations. Such an engineering experience also serves to enhance the chances that undergraduate engineering students will pursue their education up to masters or PhD proficiency. This is due to the inspiration that derives out of technical achievement and premises the engineering mindset that aspires for life-long technical excellence. Overall, the opportunity for undergraduate research presents many advantages to aid in the betterment of engineering education.

## Conclusion

Undergraduate education is perhaps the most critical aspect of higher education because its purpose serves to educate and train the next generation of professionals that will confront advancing challenges of the future. For this reason, engineering education must continue to improve in order to prepare future engineers for the vast range of technical challenges they will address. One way of achieving this goal is by providing undergraduate engineering students with rewarding research opportunities to heighten their educational understanding and gain early experience with technical procedures currently taking place within the modern engineering industry. Active research projects can provide undergraduate students with many advantages such as increased achievement, greater motivation, broader understanding of engineering sciences and disciplines, and a mindset of technical excellence. Research areas within MEMS technologies present one of the most effective opportunities due to the variety of disciplines that are applied and the large range of emerging applications. Within MEMS technology, Micro-robotic drug-delivery research has shown great success in its purpose of expanding a mechanical engineering student's perspective on education, technical knowledge and skills, and engineering aspirations. By expanding engineering education beyond the limits of core curriculum, universities can greatly improve the success of many engineering graduates and ensure the development of a strong next generation of engineers who are technically trained to meet the advanced challenges of the future. This can be achieved by implementing programs that support and reward undergraduate engineering research as an effective approach to greatly enhancing engineering education and heightening the life-long success of future engineers, the engineering industry, and most importantly, the discoveries made to further advance humankind's understanding of the world and universe.



## Acknowledgements

The authors acknowledge the financial support of the National Science Foundation under Grant Nos. 0633312 and 0637052.

## References:

- [1] Enikov, E.T. & Nelson, B.J. (2007). Accommodating the Diverse Technical Interests of Foreign Exchange Students through Participation in MEMS and Micro-Robotic Research. International Conference on Engineering Education – ICEE 2007.
- [2] Lin, L. Curriculum Development in Microelectromechanical Systems in Mechanical Engineering. *IEEE Transactions on Education*, vol. 44, 2001, p. 61-66
- [3] Adams, J.D., Rogers, B.S., Leifer, L.J. (2004). Microtechnology, Nanotechnology, and the Scanning-Probe Microscope: An Innovative Course. *IEEE Transactions on Education*, vol 47, p. 51-56.
- [4] Ishihara, K., Furukawa, T. (1991). Intelligent Microrobot Drug Delivery System Measured and Controlled by Ultrasonics. Clinical Research Institute, Osaka National Hospital.
- [5] Weiss, J. N. (1998). Treatment of Central Retinal Vein Occlusion by Injection of Tissue Plasminogen Activator Into a Retinal Vein. *American Journal of Ophthalmology* 126(1):142–144.
- [6] Gilles, G.T., Ritter, R.C., Broaddus, W.C., Grady, M.S., M. A. H. III, and McNeil, R. (1994). Magnetic manipulation instrumentation for medical physics research, *Review of Scientific Instruments*, vol. 65, no. 3, pp. 533–562.
- [7] Dogangil, G., Ergeneman, O., Abbott, J.J., Pane, S., Hall H., Muntwyler, S., Nelson, B.J. (2007) Toward Targeted Drug Delivery with Wireless Magnetic Microrobots. Institute of Robotics and Intelligent Systems, ETH Zurich.
- [8] Yevin, K.B., Vollmers, K., Nelson, B.J. (2006). Modeling and control of Untethered Biomicrobots in a Fluidic environment using Electromagnetic Fields. *International Journal of Robotics Research*, vol. 25, p.527--536.
- [9] Saslawski, C. Weingarten, J.-P. Benoit, and P. Couvreur. (1998). Magnetically responsive microspheres for the pulsed delivery of insulin, *Life Sciences*, vol. 42, pp. 1521–1528.

## Corresponding Authors:

Malcolm T. Gibson, Undergraduate Student Research Assistant (Author).  
 Eniko T. Enikov, Associate Professor and Principal Investigator (Author).  
 Advanced Micro and Nano Systems Laboratory, Dept. of Aerospace and Mechanical Engineering, The University of Arizona. PO Box 210119, Tucson, AZ, 85721-0119  
 Email – [mtgibson@email.arizona.edu](mailto:mtgibson@email.arizona.edu) or [enikov@email.arizona.edu](mailto:enikov@email.arizona.edu)

# TOWARDS A JOINT DEGREE PROGRAM IN AMBIENT COMPUTING<sup>1</sup>

Yusuf Ozturk\*, Emrah Orhun\*\*, Chris Bowerman\*\*\*

Electrical and Computer Engineering, San Diego State University\*  
 Computer Science Department, Troy University\*\*  
 Department of Computing and Technology, University of Sunderland\*\*\*

**Abstract** — *Funded by the US-EU Atlantis Program, International Cooperation in Ambient Computing Education (ICACE) Project is establishing an international knowledge-building community for developing a broader computer science curriculum aimed at preparing students for real-world problems in a multidisciplinary, global world. ICACE is collaboration among three US and three EU universities joined forces to create a core curriculum in Ambient Computing. The curriculum will include aspects of social science, cognitive science, human-computer interaction, organizational studies, global studies, and particular application areas as well as core computer science subjects. Programs offered at partner institutions will form trajectories through the curriculum. A degree will be defined in terms of combinations of trajectories which will satisfy degree requirements set by accreditation organizations. The curriculum is evolving with student and faculty exchanges on both sides of the Atlantic and expected to lead to joint- or dual-degree programs among the partner institutions in the future.*

*Index Terms* — *Joint degree programs, ambient computing, computer science education, student mobility*

## 1. Introduction

The field of computer science (CS) education is in the process of a major paradigm shift as a result of the challenges the CS community is facing in the definition, purpose, pedagogy, and curriculum drives of the field as well as declining students. On the one hand, a global market requires graduates with a broad computing education who can master the context and work in multidisciplinary and international settings. On the other hand, with the marrying of CS with other disciplines such as psychology (in the area of human-computer systems), language and communication (in the areas of usability and content creation), business (in the area of technology driven proximity marketing), sociology (in the area of social networking via computers and forensic and terror networks) computing, graduates are increasingly required to have multidisciplinary knowledge and abilities. This, coupled with the emergence of new subfields such as bioinformatics and significant growth in the body of knowledge in existing subfields such as software engineering means that taught undergraduate and even taught postgraduate CS degree programs can no longer cover comprehensively all aspects of the field.

Institutions across the world are addressing these challenges through development of new programs or courses that focus on computing in context rather than the computer. Three US and three EU universities formed a consortium to carry out a project entitled International Cooperation in Ambient Computing Education (ICACE). This consortium aims to broaden the perspective of computing students through curricular innovation and

---

<sup>1</sup> Funded by The Fund for the Improvement of Postsecondary Education (FIPSE) and The Directorate General for Education and Culture of the European Commission under the auspices of EU-U.S. Atlantis Program (FIPSE P116J07-0057 and EU 2007-2065/003-001 CPT-USMOBI).

international mobility. The project aims at developing and delivering a CS curriculum that will give students the education needed for effectively addressing real-world problems in a multidisciplinary, global world. ICACE Project was one of the 14 projects chosen for funding in 2007 by the EU-U.S. Atlantis Program. The total cost of the U.S. program is funded by The Fund for the Improvement of Postsecondary Education (FIPSE) of the U.S. Department of Education, while the Directorate General for Education and Culture of the European Commission is funding the European part of the project for a period of four years. The project is collaboration among Troy University (USA), University of Sunderland (UK), Fernuniversität in Hagen (Germany), University of Algarve (Portugal), University of Arkansas at Little Rock (USA) and San Diego State University (USA).

The ambient computing curriculum will include aspects of social science, cognitive science, human-computer interaction, organizational studies, global studies, and particular application areas as well as core computer science subjects. Programs offered at partner institutions will form trajectories through the curriculum. A degree will be defined in terms of combinations of trajectories which will satisfy degree requirements set by accreditation organizations. This is expected to lead to joint- or dual-degree programs among the partner institutions in the future. A total of 48 students is expected to take part in the mobility scheme which will involve spending one semester (4-6 months) at one of the partner institutions across the Atlantic. This paper describes the goals and activities of the project and discusses current implementation issues.

## **2. The project's goals**

The goals of the project align with the expectations of the EU-US Atlantis Program and include the following:

- To integrate multidisciplinary knowledge into current computer science courses for taught undergraduates and masters students.
- To directly influence curriculum developments in partner and other institutions by means of curriculum development teams, practical experience of student and staff exchanges and dissemination workshops. This will be furthered by staff exchanges which will provide 8-10 staff with benefits from alternative perspectives, new training materials and approaches. These will take place largely in the first half of the project as materials are redeveloped to embody a full multidisciplinary, global perspective and are made available on the electronic learning platform.
- To provide 48 students with benefits from global exchange and training activities and in addition, by means of local, national workshops and online communities of practice, spread the benefits to a further 60 non-exchange students and around 20 academics.
- To disseminate proven practices, models and study programs.

## **3. Planned Activities**

The project and its aims have been developed not only to meet a need for computing workers of all levels but also to meet the needs of the institutions involved. A range of activities have been planned to achieve the project's goals. The planned activities cover development of international curricula, organizational frameworks for mobility, language and cultural preparation and assessment, promotion and dissemination, and evaluation.

### 3.1 Development of International Curricula for Ambient Computing

The terms ambient, pervasive, and ubiquitous computing have been used to characterize a future with electronic environments that are sensitive and responsive to the presence of people in an invisible way. Weiser [1] referred to technology that “recedes into the background of our lives” and can be used “without even thinking about” it as “ubiquitous computing”. The European Union’s Information Society Technologies Program Advisory Group (ISTAG) used the term “ambient intelligence” to describe a vision where “people will be surrounded by intelligent and intuitive interfaces embedded in everyday objects around us and an environment recognizing and responding to the presence of individuals in an invisible way” [2]. Such extension of computing into everyday life presents challenges across computer science and necessitates understandings of the social, cultural and psychological phenomena surrounding the context in which the computer is used. In the ICACE project, we assume that the notion of ambient computing entails understandings of those social, cultural and psychological phenomena as well as the notions of ubiquitous computing and ambient intelligence.

The ICACE project aims at developing and delivering CS curricula that will give students the education needed for effectively addressing real-world problems in a multidisciplinary, global world. The ambient computing curriculum will be a framework for unifying the CS curricula offered by partner institutions. It will include aspects of social science, cognitive science, human-computer interaction, organizational studies, global studies, and particular application areas as well as core computer science subjects.

CS programs offered at partner institutions will be formed into trajectories (a set of cohesive, coordinated local contexts for understanding CS) through the courses that comprise the curriculum. These trajectories will be enhanced and refined over the course of the project such that on its completion a common degree will be defined in terms of combinations of trajectories which will satisfy degree requirements set by accreditation organizations on both sides of the Atlantic. This is expected to lead to follow-on activities in developing joint- or dual-degree programs among the partner institutions. It is anticipated that existing courses across the partner institutions will cover most of the areas needed in the curriculum with new and modified course content being developed during the project to address additional needs. The global studies aspect of the curriculum will start internationalization of education at home and will be the basis for additional internationalization through student mobility.

In connection with development of international curricula, a project curriculum team will be set up to take a multidisciplinary view of computing and will comprise members from all institutions on both sides of the Atlantic from each of the disciplines that may be relevant to ambient computing—sociology, psychology, business, language, computing and communication. This team will meet via Skype conferencing at project start and thereafter six monthly meetings to discuss trends, areas of currency and importance for curriculum development. The curriculum team will determine courses which need enhancing and developing. It will then agree to develop courses at one or more institutions. This will enable curricula to be kept up to date and to provide courses to students at partner sites which might not otherwise be possible. They will also bring

together staff to produce the learning content. Such staff will be invited to undertake staff exchanges for such curriculum development.

Biennial workshops will be held with a multidisciplinary, global and real-world focus in order to involve students in curriculum development. These workshops will engage student participants of all levels (undergraduate and graduate masters) in project work on real-world tasks which require integrative and multidisciplinary skills. Staff and graduate students of the institution hosting the workshops, who are not able to undertake exchanges will be encouraged to offer their expertise and participate in the activities to raise the quality and achievement of the student groups. The first of these workshops is hosted by San Diego State University and will be held on May 20, 2009. The website for this workshop is hosted at <http://icace.sdsu.edu>. The focus of the first workshop is on how to educate engineering students for today's global economy and how to internationalize our curricula. The workshop also aims to create a forum for discussion of Ambient Computing curriculum. We invite presentations that address both cultural, curricular, logistics and technical issues around educating global engineering workforce in this era of change.

An important goal of the project is to address the social aspects of learning and knowledge-building. Faculty, students and administrators in the partner institutions will aim at establishing an online knowledge-building community where a common goal will be development of individual and collective understanding in CS. In this community, technology will be used for building the social context as well as for knowledge sharing and process support. Social networking tools including myspace type facilities, wikis, blogs, user groups and forums will be used for collaboration and reflection as part of the learning landscape as well as for preparing students for study abroad. A particular attention will be paid to utilizing existing digital libraries such as National Science Digital Library and MERLOT that have collections relevant to CS for shared repositories of learning materials.

### **3.2 Development of Institutional Frameworks for Mobility**

The commitment and the formal administrative arrangements for the project were stated in the Memorandum of Understanding (MoU) which was signed by all partners in advance. According to MoU, exchange students will be expected to pay the appropriate tuition relevant to their home institutions and each institution agrees in advance to allow for the appropriate transfer for credit and grades to the home institution. The partners have agreed to use European Credit Transfer System (ECTS) credits as a common currency of exchange so that courses can be compared and weighted against each other. Students on the program will be issued a EUROPASS style record of achievement during their exchange.

Each institution will set up an ICACE project team comprising: the institutional contact, academic program managers, student service providers (e.g., accommodation, international office, EFL/Modern languages units) to ensure that all arrangements for exchanges are in place and working well. The chair of this group will be the institutional contact for the ICACE project and will email an action plan to members of the group as well as project partners.

The project partners will meet regularly to have oversight and management of all aspects of the project: curriculum issues, exchanges, and finance. There will be additional monthly meetings of the contact persons at each institution via Skype to monitor the achievement of tasks and ensure good financial budgeting.

Communications, collaboration and information access is organised by means of a content management system, which is provided by FernUniversität in Hagen and which underpins the project for both staff and students. The software allows the establishment of overlapping communities with community-controlled privacy and visibility of information and services maintained by each community. Skype conferencing will be used monthly to monitor completion of project tasks and budgets. Partners will also communicate by email. The communication among participants of the program and project members will later be published as a FAQ to provide first step help to future combatants of international exchange experience. The project portal hosted at <http://icace.dvt.fernuni-hagen.de/> also serves as the main website to give information to the public and will link to the social networking environment.

### **3.3 Language and Cultural Preparation and Assessment**

There is a need for appropriate language and cultural orientation training for students taking part in the exchange program in order to become acquainted with different approaches and cultures. It is expected that preparatory courses will be run by home institutions before departure, that induction and further courses will be run by the host institution after arrival. It may be expected that students have a reasonable mastery of the language of the host institution or that the host will, in exceptional circumstances, be able to hold courses in a common language (e.g., English) for participating students. The modern languages and foreign languages units may also run sessions for departing students on customs and cultural issues in order to orient the students before arrival. There will be additional practice offered by electronic means before departure. This will include the use of electronic language tutors and social networking. An online student community linking staff and students at all partner sites will be built. This will enable social networking so that customs can be discovered and discussed, language practised and friendships developed. The online community will also offer online radio, TV, newspaper links so that students can begin to understand local events, history and places. Students will be encouraged to find out about the traditions of the nations, submit written reports on what they have discovered, make oral presentations and compile a list of the 10 things that they wish to do when abroad.

On arrival students will be offered additional modern languages support by the appropriate language training unit within the host institution. This will also ensure that all students make contact with others, are aware of several members of staff who can offer support and have a forum in which to discuss culture and customs. Students will be assigned both a tutor for their pastoral care and a mentor from the host institution's peer group. The tutor will be expected to: give the student a tour of the area, offer transport to local shops, organise an opportunity to socialise, discuss matters of personal safety and health as well as act as a resource for getting questions answered. The student mentor will be on a

similar course of studies and will be able to act as a link with the peer group, offer advice on expectations and help with language issues in class

### **3.4 Promotion and Dissemination**

Partners will aim at raising awareness of the scope of the project and its aims with program management teams at undergraduate and graduate levels by briefings in the institutions. From project commencement there will be a project newsletter which is aimed at keeping the program in the view of students and staff. ICT will be used to create an online community across all institutions not only for language, culture and academic reasons but also to showcase exchange experiences and increase the hunger of students to participate. It is intended to integrate undergraduate and postgraduate students. This offers a number of advantages: maturity and experience of the older participants can be used to support and encourage those who are younger. Also, by breaking down artificial academic divides it brings together a community which offers an experience much more close to the mixed ages, experiences, backgrounds and cultures of the workplace.

The dissemination strategy, outlined below, will ensure that the results of the project will be used by the target groups, target sectors, and potential users. Certain activities will be directed towards individual target groups. For example, dissemination towards the universities involved in this project will be done on an on-going basis and the formation of Special Interest Groups (SIGs) will help ensure that information about the project is spread down to grass roots level in each partner country and beyond.

The experiences acquired in a previous Transatlantic Mobility Project taught us that comprehensive information, trust building, cultural, and language preparation are core elements that need to be addressed in a dissemination strategy as well. The main elements of the dissemination strategy include:

- A comprehensive web portal.
  - Providing course broker functionality to find courses matching a student's particular interest and needs and combine them to admissible course packages and curricula.
  - Listing the working papers and experience reports from students and faculty and guidelines.
  - Listing contact information, related university sites.
  - Giving access to student administrative services and personal information including a self-presentation of faculty and exchange students.
- Social software including wikis, bulletin boards, chat tools, network formation tools to support permanent and sustainable interaction between faculty and exchange students. These tools will also be linked from within the project portal.
- The project SIG through which the interested public throughout the world will be informed about the project and able to contribute their experiences and discuss their problems with the project participants. The main SIG will have sub-SIGs formed on a national basis where interested parties will be invited to enrol. For example, the Californian SIG will invite members from academia and industry thematically related to the project's curriculum topics such as Nokia, Qualcomm and also companies that have an interest in hosting exchange students for a short practical. This will be

repeated in the partner countries. The aim behind the formation of nationally significant SIGs is to maintain and foster relationships on an on-going basis at a local and national level.

- The book of the project, which will be published within the life of the project and distributed to stakeholders and decision makers on educational mobility throughout the world.
- The project will maintain an open access Technical Report series to enable the rapid publication of project results. Exchange students will be encouraged to contribute research articles and experience reports in this series. The writers workshop being part of the project curriculum aims to raise their technical writing skills.
- Two road shows, one on each side of the Atlantic will be held in the first year of the project at which the local students will obtain the possibility to learn about the mobility program, curricular components and cultural information and meet the faculty involved in the exchange program.

### **3.5 Evaluation Plan**

The project will be evaluated against its goals and objectives. The goal of the project is to co-operate to exchange, evolve and combine educational offers related to ambient computing, and to allow selected exchange students to custom-design their curricula and study at least one semester abroad (on the other side of the Atlantic). The evaluation plan outlines key evaluation questions, strategies, and data collection/analysis procedures for the formative and summative evaluation of project implementation, results, and impact in connection with project objectives that lead to the project goal. An external evaluator will develop a formal and comprehensive evaluation plan for the project. He will meet with partner institutions, analyze and report evaluation activities, participate in annual program and/or consortium meetings and contribute to annual and final project reports. Formative evaluation will be used to guide project development and implementation including curriculum development and dissemination. Summative evaluation will assess achievement of project objectives and document the impact of project including impact on student learning. Key evaluation questions are intended to examine the areas of curriculum development (student responses to the curriculum and new courses, faculty responses to new needs, institutional responses to the project) and student experiences with international mobility.

### **4. Status of the project**

The project has completed its first year, finalising agreements between partners, developing databases of modules, examining curricula and looking at gaps which need to be filled. These completed sets of modules will be turned into trajectories of modules which allow degrees to be awarded for study at different EU/US partners.

Student mobility has so far been limited in comparison to the anticipated levels, but we expect to see increased mobility in the second year. One major issue concerning student mobility is the requirement for a full semester (minimum of four months) study abroad. In general student interest in mobility has been lower on the US side. SDSU received 5 students from University of Sunderland and no SDSU student chose to study in Sunderland. SDSU received 8 students from FernUniverstat in Hagen in the same period



while only 5 students from SDSU choose to study in Germany for a short time. In the current project cycle, we have 6 students from Germany and only one student from SDSU joined the program. Several factors including the lifestyle of our students contributed to this according to our first assesment. We are working on improving student interest in the program by emphasizing the importance of international experiences in a global world. We are also organizing a workshop at SDSU to increase student awareness in international opportunities.

Curriculum development efforts have focused on collection and standardization of curriculum descriptions, database and broker interface design and data input and interface implementation. Partners have also started to explore how to mechanize the anticipated curricular changes within their individual institutions and some new courses have been proposed.

A project portal has been created to bring together all academic requirements and practical information from the partner universities necessary for student mobility. This portal can be visited at <http://icace.dvt.fernuni-hagen.de/>. In addition this portal offers a secure file management system which is used for internal communication among project partners. Work has also been undertaken to build a community of practice of staff and students which will not only support staff and students on exchanges but the general academic area beyond the lifetime of the current project.

## 5. Acknowledgment

The ICACE Consortium is composed of Coskun Bayrak, University of Arkansas Little Rock, Arkansas; Chris Bowerman, University of Sunderland, U.K. (EU Project Leader); Bernd Krämer, FernUniversität in Hagen, Germany; Emrah Orhun, Troy University, Alabama (US Project Leader); Yusuf Ozturk, San Diego State University, California and António Ruano, University of Algarve, Portugal. The project proposal, on which this paper has been based, was jointly developed by the consortium partners.

## 6. References

- [1] Weiser, M, "The Computer for the 21st Century", *Scientific American*, (Special Issue: Communications, Computers, and Networks), Volume 265, Number 3, September 1991.
- [2] IST Advisory Group Ambient Intelligence: from vision to reality. Retrieved November 22, 2008, from [ftp://ftp.cordis.lu/pub/ist/docs/istag-ist2003\\_draft\\_consolidated\\_report.pdf](ftp://ftp.cordis.lu/pub/ist/docs/istag-ist2003_draft_consolidated_report.pdf)

**Dr. Yusuf Ozturk** is an associate professor of electrical and computer engineering at SDSU. He has been a long time advocate of international experiences in a global economy. He is a partner of the ICACE consortium. His research interests include mobile and pervasive computing, computer networks and embedded networked applications.

**Dr. Emrah Orhun** is a professor of computer science at Troy University, Alabama. He is the US lead for ICACE consortium. His research interests include artificial intelligence, ambient computing and computer aided education.

**Dr. Chris Bowerman** is a professor of computer science in University of Sunderland. He is the EU lead for ICACE consortium. His research interests include artificial intelligence, ambient computing, forensics and computer aided education.

## **Engineering 101: Peer Teaching with LEGO NXT Robotics**

**Stephen Beck<sup>1</sup>, Joshua Brent<sup>1</sup>, Thomas Brown<sup>1</sup>, Agostino Cala<sup>1</sup>,  
Eniko T. Enikov<sup>2</sup>, Richard Lucio III<sup>1</sup>**

**<sup>1</sup>Undergraduate Student Mentors; <sup>2</sup>Faculty advisor**

**Advanced Micro and Nano Systems Laboratory, Department of Aerospace  
and Mechanical Engineering, The University of Arizona**

### Abstract

The vast amount of knowledge and the multitude of disciplines encompassed by engineering can often be intimidating and difficult, creating an educational barrier for beginning students. The goal of an introductory engineering class is to present engineering as an exciting and welcoming field of professionals who work together to solve problems. An introductory engineering class that lacks creativity, teamwork and encouragement often fails to inspire students and may turn some away from engineering. This paper describes a modern approach to team-based learning and peer teaching in the context of an introductory course for freshmen engineering students. More specifically, the use of LEGO NXT<sup>®</sup> construction kits was tested as tool to enhance the experience of group projects. LEGOs are approachable, intuitive and have application in numerous construction projects. The low cost, reusability, and availability of a variety of sensors for LEGO kits make them ideal teaching materials compared to other expensive, specialized products. Our project involved presenting students with a task of designing a ribbon-climbing robot which must detect a randomly placed marker and report its height through a wireless communication link. The students were provided with basic mechanism design formulas and calculations allowing them to optimize their design. The project culminated in a final competition between the teams in the class. The project emphasized self- and team learning. The teamwork and the final competition encouraged flexibility, interaction and support between the students, behavior necessary of successful engineers.

### Introduction

Engineering is often a daunting subject for incoming students. Lack of knowledge about their chosen field can be very intimidating to new engineering students, and may result in difficulty maintaining high retention rates in engineering disciplines among undergraduates <sup>[4]</sup>. Introductory courses aim to inform students about both their field of interest and what skills and processes are needed to be a successful engineer <sup>[1]</sup>. However, it is often difficult to construct a course that introduces concepts of the different engineering disciplines while developing team working and project design skills that does not also require prerequisite knowledge, specifically

within math and science. Students frequently enter college without sufficient knowledge in these areas that would allow for more complex projects in their introductory courses<sup>[4]</sup>. This often results in introductory engineering courses that are remedial and boring, potentially deterring students from pursuing engineering.

Beginning courses often employ projects that are contrived such that a “correct” solution is made apparent at the beginning and does not require an iterative design process. For example, the introductory course ENGR 102 at the University of Arizona uses a catapult project in which students must launch a ball a certain distance by utilizing different configurations of rubber bands on a pre-constructed wooden catapult. One student could easily arrive at the “correct” solution without consulting their team, making it both a pointless and boring exercise that does not meet the intent of an introductory engineering course. In order to create a more exciting and relevant project for undergraduates, a replacement project employing the LEGO NXT© construction kit was implemented in ENGR 102 classes. LEGOs are an ideal educational engineering tool, incorporating a highly versatile construction set that is approachable, intuitive, and not prohibitively expensive allowing iterative designs and implementation of projects with a team<sup>[2]</sup>.

## Methods

Students were given the task of building a robot capable of climbing a ribbon. ENGR 102 students were provided with basic information about the LEGO NXTs, specifically graphs on motor information (Fig 1; Fig 2).

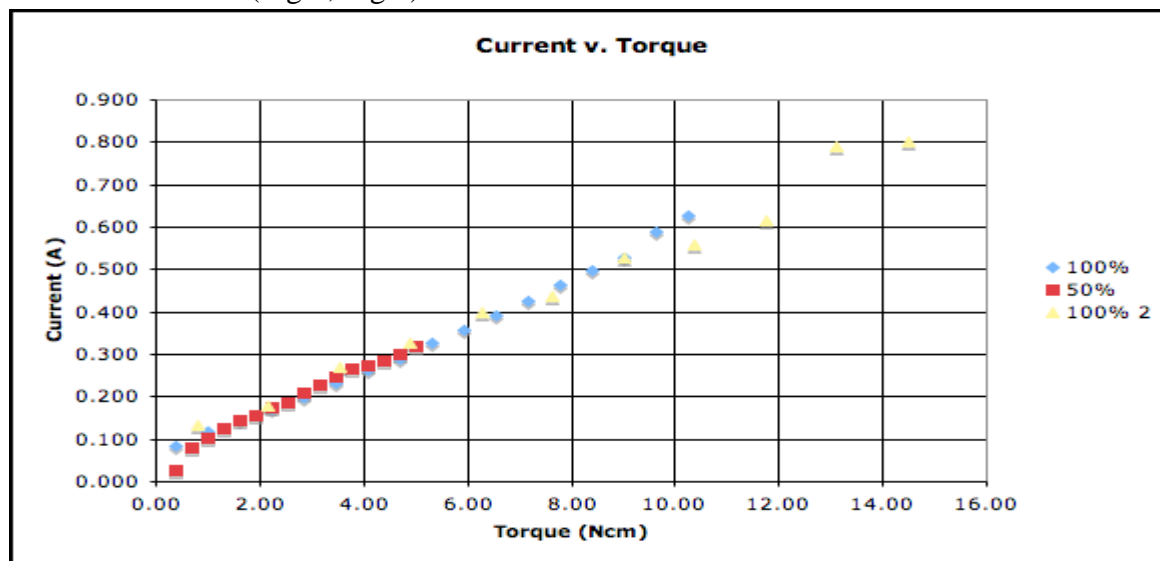


Figure 1: LEGO NXT motors Current vs. Torque Graph. The Blue and Yellow data points are with the motor running at 100% power: blue with a small hub for the pulley, yellow with a large hub. The Red data points are with the motor running at 50% with the small hub<sup>[5]</sup>.

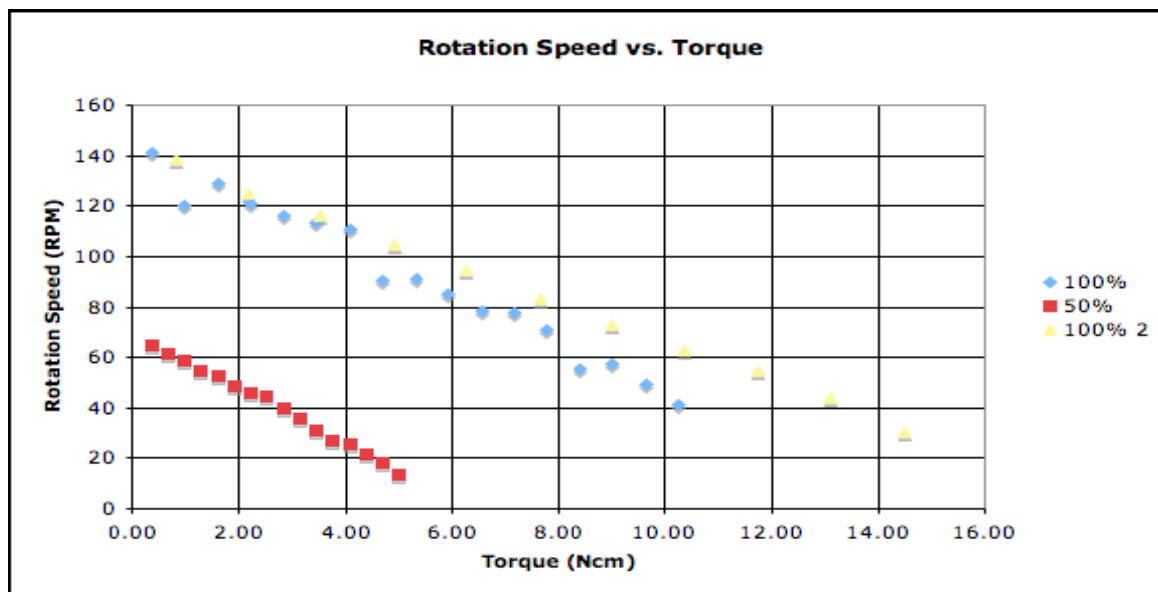


Figure 2: Angular Velocity vs Torque of a LEGO NXT motor. The Blue and Yellow data points are with the motor running at 100% power: Blue with a small hub for the pulley, Yellow with a large hub. The Red data points are with the motor running at 50% with the small hub<sup>[5]</sup>.

Given the graphs and an overview on basic physics, the students were given the details of their assignment: design a robot that could climb a ribbon two stories, stop at markers at unknown distances along the ribbon, send information on height of the markers (from the bottom of the ribbon) wirelessly to a robot on the ground, and return to the ground after making it to the top. The final setup for the competition can be seen in Figure 3.



Figure 3: Ribbon set up with two robots attempting to complete their goals. Note one robot is winding the ribbon while the other is rolling along the ribbon<sup>[3]</sup>.

The students' last goal was to accomplish all these tasks in the shortest amount of time possible. The project culminated in a two day competition. The first day gave the students a chance to test their designs outside at the full two story height. The second day was the actual competition in which the students placed their designs head to head with their fellow teams. The goals of the project forced the students to take important factors under consideration, including the final weight of their robot, number of motors to use, and which sensors were most appropriate for the various task. The students were also required to learn the LEGO programming language, based on Laboratory Virtual Instrumentation Engineering Workbench (LabVIEW), a visual based programming language.



Figure 4: A team of students admiring their hard work on competition day<sup>[3]</sup>.

## Results

Many students were very receptive to the project – they enjoyed being given a specific goal with few constraints, similar to real life engineering situations. The project required introductory programming and basic mechanics principals, thus introducing some basic concepts from Mechanical, Computer and Electrical engineering, while remaining simple enough for entry level engineering students to succeed. The two day competition as well as in-class testing required the students to use an iterative design process if they wanted to be successful. Between the first and second day of the competition, many teams discovered flaws in their initial designs and corrected these flaws before the final day of competition.

## Discussion

The goal of the LEGO ENGR 102 project was to design a project for introductory engineering classes that covered a spectrum of engineering disciplines while being simple enough for

incoming freshman to understand. Furthermore, it was important that the project was interesting and necessitated teamwork while requiring the students to go through an iterative design process. In this regard the project successfully met its goals. Students remained interested in the project, working in teams and brainstorming alternate designs to maximize the speed and efficiency of their robots.

The ENGR 102 class use of the LEGO NXT opens many opportunities to expand or change the 102 project entirely to fit the needs of the students. Currently our lab has been able to power an NXT using silicon solar panels. This would allow a solar variant of this project to be incorporated, introducing yet another pertinent and exciting subject, renewable energy, to incoming engineering freshman. While being more complicated than running an NXT off of a battery, the concepts of supplying enough voltage and current through series and parallel panels is a simple subject that can be broached with incoming or first year students while maintaining their interest. Other projects demonstrating the versatility and possible direction for future introductory engineering projects include an autonomous LEGO soccer field with remote controlled soccer playing robots, another system developed in our lab.

LEGOs are extremely versatile and with their many sensors (touch, light, ultrasonic rangefinder, as well as many aftermarket custom sensors) can be made to model many systems that today's upcoming engineers might encounter when moving into the workforce. This system prepares students for the problem solving and designing process required of engineers while being presentable in manner that is both welcoming, relevant, and within the intellectual reach of incoming freshman engineers.

#### Acknowledgements

The authors acknowledge the support of Dr. Jeff Goldberg and Dr. Kathleen Melde for incorporating this project in their ENGR 102 classes and the generous support of the STOMP program of the Center of Engineering Education and Outreach at Tufts University.

#### References

- [1] General Catalog Spring 2009 Course Description: ENGR 102 – Introduction to Engineering (2009) Retrieved February 1, 2009, from University of Arizona General Catalog Web Site: <http://ruby.ccit.arizona.edu/academic/catalog/display-course-description.php?url=http://catalog.arizona.edu/courses/091/ENGR.html&courseID=ENGR102>
- [2] M. Cyr, V. Miragila, T. Nocera, C. Rogers, A Low-Cost, Innovative Methodology for Teaching Engineering Through Experimentation. *Journal of Engineering Education*, 86(2), 167-171, (1997)

- [3] P. Brown, (2008) ENG 102 Lego Robots. Retrieved February 1, 2009, from ENG 102 Lego Robots. Web Site: <http://picasaweb.google.com/uaeng.petebrown/ENG102LegoRobots#>
  
- [4] Seymour, E. Guest Comment: Why Undergraduates Leave the Sciences. *American Journal of Physics*, 63(3), 199-202, (1995)
  
- [5] T. Brown, (2008). LEGO NXT Motor Analysis. Retrieved February 1, 2009, from University of Arizona LEGO Robotics Outreach Club homepage Web Site: <http://roboclub.arizona.edu/pages/gallery/nxt-motor-tests.php>

### Biographical Information.

**Richard Lucio III** is currently a Junior in the Electrical Engineering department at the University of Arizona and a Member of the University of Arizona Lego Robotics Club. He has spent three years teaching summer school programs for elementary school children using LEGO Mindstorms. He is also a recipient of the University of Arizona NASA Space Grant (2008). He and a team of three other students won a design competition in a microcontroller design class (2008) with their design of a microcontroller for a toaster.

**Thomas Brown, Stephen Beck, Joshua Brent, and Agostino Cala** are undergraduates in the College of Engineering at the University of Arizona, and members of the University of Arizona Lego Robotics Club.

**Eniko T. Enikov** is an Associate Professor of Aerospace and Mechanical Engineering at the University of Arizona. He received his PhD degree from the University of Illinois at Chicago in 1998. Since then he has worked as a post-doctoral associate at the University of Minnesota and subsequently as an Assistant and Associate Professor at the University of Arizona. There, he established the Advanced Micro and Nanosystems Laboratory with sponsorship from multiple federal agencies (AFOSR, NSF, DOE, DE) and the private sector. Prof Enikov has also led numerous educational programs including summer school in micro-systems design held in Udine, Italy, 2004, student exchange programs with ETH, Zurich, Budapest University of Technology and Economics, and Slovak Technical University of Bratislava. Prof Enikov is a recipient of several prestigious awards including NSF Career award (2001), US Dept. of State Fulbright Research Scholarship in Hungary (2007).



## Teaching Online in Electrical Engineering; Best Practices Experiences and Myths

Bruno Osorno  
California State University, Northridge, California

**Abstract-** Online teaching is here to stay. We cannot longer deny or refuse to teach on line, therefore we must reinvent ourselves and develop skills that we did not have or did have and did not know it. This paper attempts to describe the practices we have had in the teaching of electrical engineering courses online. We will show how effective, ELLUMINATE™ has become versus the classic face-to-face classroom teaching. To do so we split one class in two sections; the first one is the online section and the second one is the classroom face-to-face section. To reduce duplication, while the on line section is taking the class; the classroom face-to-face section takes the class via an LCD projector.

The time has arrived where all students have a laptop or have a PC at home. 90% of the students taking these classes own a laptop with wireless communication. It is very encouraging to see that the students in the classroom face-to-face class have their own laptops connected to the online class so that they can minimize note taking and pay more attention to the lecture. The question is; how do I make sure that students outside of the classroom are connected to the online class? The answer is in the software that we use. Basically, we have a list of students logged on to the left side of the screen. Furthermore, there is an interactive aspect of our system via sound and video. I do prefer sound only so that those students that do not have access to a large broadband ISP, at least they can listen and talk without many interruptions or slowing down their system.

**Discussion-** Higher education is making a change from classroom education to online education. The enrollment of online education keeps going up at a very fast rate in the United States. In 2004 [12] about 2.35 million students where enrolled in online courses. The following table indicates the “online course penetration-Fall 2004”

The following table applies for institutions with 3000 to 7500 students

Level	Doctoral/research	Masters	Bachelors	Associate	Specialized
Undergrad	64.3%	67.6%	33.9%	77.5%	31.7%
Graduate	78.9%	65.8%	32.2%	100.0%	58.2%
Continuing Ed	74.1%	48.5%	29.1%	70.8%	26.3%

For instance, the table indicates that 78.9% of all institutions in the United States offer online courses at the doctoral/research level. The Associate (two year institutions), all offer online courses at the graduate level. This is because only very few of the two year institutions offer

graduate level courses. The increase of approximately 360,000 online students/year has exceeded the overall rate in higher education enrollment/year and keeps growing [12]

The following table applies for institutions with 15000+ students enrolled [12].

Level	Doctoral/research	Masters	Bachelors	Associate	Specialized
Certificate	60.3%	40.8%	17.2%	32.2%	22.8%
Associate	43.9%	23.3%	25.7%	42.8%	23.0%
Bachelors	38.4%	34.45	19.0%	23.1%	22.8%
Masters	65.7%	45.3%	25.8%	50.0%	35.0%
Doctoral	16.4%	13.3%	0.0%	0.0%	9.3%
Professional	24.7%	11.9%	11.1%	19.0%	8.4%

It is believed that “students need more discipline to succeed in an online course” [12] and 70.0% of the institutions surveyed agreed, only 2.6% disagreed. Along the same line “teaching an online course takes more faculty time and effort, 38.2% of the institutions surveyed agree.

The “legitimacy of online education,” [12] has been a great issue for most faculty. This myth can be clarified by indicating that 36.4% of the public institutions surveyed agree that online teaching is a legitimate approach to teach and only 4.9% disagree. Indeed 58.6% remain neutral.

“*The one percent solution*,” [13] became an eye opener. It indicated that in a two year institution 1% of the courses attracted 44% of the enrollment and the passing rate of these courses is 64%. The conclusion is that in any institution there are courses that attract the majority of the enrollment and they could be targeted for online teaching.

Universities have been developing strategic plans to tackle the implementation of online teaching. The major hurdles needed to overcome are; *changing the mindset of faculty, budgets, teacher training in new technologies, online student population’s new studying habits and quality of instruction.*

#### *Change*

Change is never easy; perhaps it is the most difficult hurdle in online teaching. Faculty, need to be fully aware of the linking of *pedagogy, technology and learning-styles* [2]. Furthermore, it has been our experience that the need of “electronic textbooks availability” is a critical event that facilitates online teaching of electrical engineering in a very large scale. (Which by the way, it is happening very fast)

#### *Budget*

Online teaching is expensive. Simply put: technology costs large sums of money. Only the software and hardware used to deliver lectures absorbs a large percentage of the budget. For example, at CSUN we use Webct™, Elluminate™, in the software area; LCD projectors, Smart boards, Tablet PCs and smart classrooms in the hardware area.

### Training

Many of the faculty teaching online had to be retrained and supported by technicians. This, also, costs money and time. At CSUN we have workshops throughout the calendar year and staff dedicated to support online teaching

### Students

As mentioned before change is not easy and online students have to change their studying habits and personal time planning. One major change is the ability to self study (self discipline). We would assume that college students would have such skill, but we are finding out that that is no the case.

### Quality of instruction

Quality of instruction is a big problem. Not everybody can do well taking an online course, therefore, this issue becomes an assessment issue. The monitoring of quality instruction and its effectiveness is still in progress and there is no a definite answer available. A common assessment is student achievement and satisfaction, but it is not enough to arrive to a conclusive result. 80.2% of the institutions surveyed [1] agree do not agree that “It is more difficult to evaluate the quality of an online course than of a face-to-face course.”

Finally the big question becomes; *where is online teaching going? Why online teaching?* The answers will be attempted on this paper.

**Online in EE**-The previous discussion was created to set up the scenario of what we have done since the Fall semester of 2006. In this section we will indicate the implementation of an online graduate level course in Electrical Engineering. This course has been taught for several years in the face-to face (classroom) mode and it has had the usual outcomes of such way of teaching. However, online teaching created a challenge of great magnitude at the logistical and instructional, and learning level.

We use “Elluminate™” as well as “Smartboard™” as our technology medium. This system was effective but only to certain degree. For example, since we did not have our lectures prepared in “power point format” and did not have an electronic version of the textbook, we needed to scan our lecture notes. That was a major time consuming issue. The advantage of Elluminate™ over Webct™ was the ability of having sound, video and pc screen via internet. In combination with Smartboard™, it made the delivery of the material quite easy compared to Elluminate™ alone.

The delivery of the material using this system created a challenge. We first used our scanned notes to do so and it became very clear that the level of detail in the explanation and discussion achieved in the face-to-face mode was not achieved in the online mode. We had to adjust and do the best we could. The major change was the delivery of the material in a mostly verbal mode. Another change was the presentation of the major highlights of the discussion and the consistent questioning of the faculty trying to get some real-time feedback from students.

Since our goal is to engage our students and create the environment for deep learning of electrical engineering, we came up with a “funnel” approach. Figure 1 shows what we consider

the way we must engage [3] students into deep learning. Keeping that in mind, we started to create our own online model for this class.

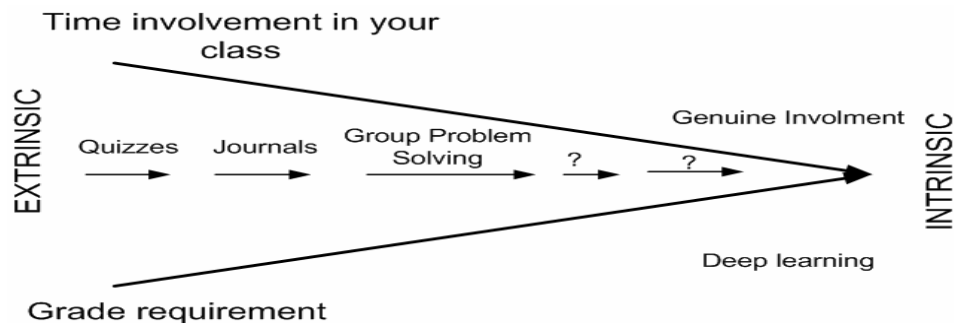


Figure 1 Student Engagement

Soon into the semester, it was obvious that a change was needed to deliver the content of the course more effectively. It was decided to require the use of Matlab™ in some assignments and it was used as a tool to explain EE concepts. While this method worked for a while, there were some issues with the access of Matlab. Students had to buy their own version since they could not get to campus to use the University computers. Power World is software that we have been using sporadically. Since the student version is free, the access to it was not a problem

**Lectures**-We posted lectures in Webct™ at least four days in advance. Students had a chance to read the lecture and print it. Two very important observations came to light; one *that students did expect to see the material in advance* and two *that students would print the notes*. Handwritten notes were acceptable because Elluminate™ and Smartboard™ allowed us to write on top of the notes; consequently we have Image, Sound and Editing (ISE) all real-time. Ideally you want to upload the power point images provided by most textbooks and then use ISE.

**Expectations**- Partlow and Gibbs [4] found that online courses should be relevant, interactive, project-based, and collaborative and should, furthermore, give learners some choice or control over their learning. Another study performed by Keeton [5] found out that *instructional strategies that promote an environment of learning, supports and encourages inquiry, broadens the experience of the subject matter and elicit active and critical reflection by learners is a reasonable expectation for teaching a class online or not*. In our case most of the arguments given by [4] and [5] were accomplished. Simply put, we came to the realization that a project oriented course in engineering is not a bad idea, group work was mandated and encouraged and definitely we had a great level of interaction online. Data analysis was by default the most important aspect of the course because of the nature of the class.

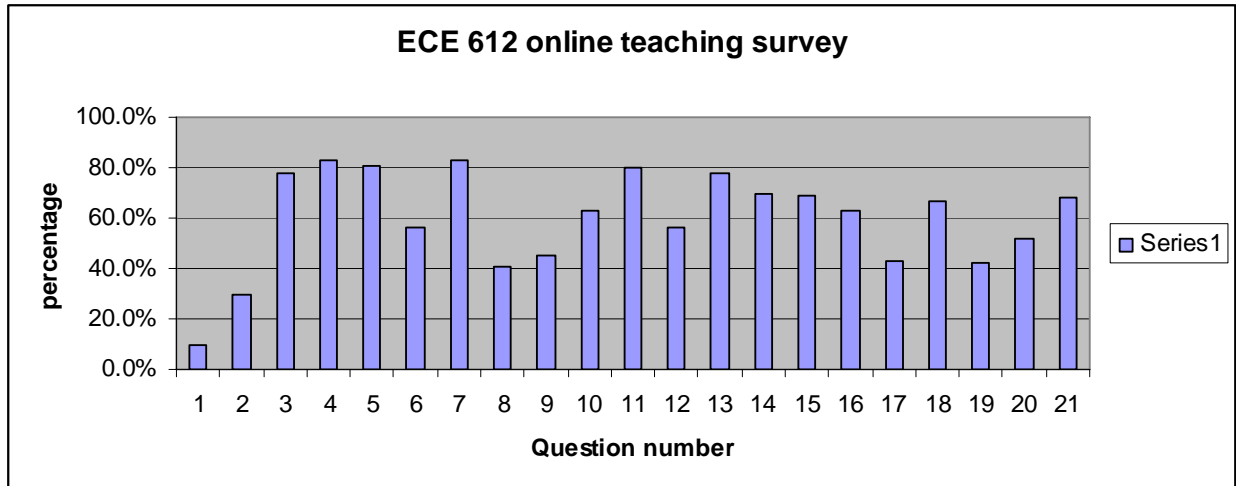
However, Bonk [6] found out in a survey that between 23 to 45 percent of online instructors used hands on experience, interactive labs, data analysis, and computer simulations.

### Online teaching surveys [8]

Bonk and Kyong performed a survey in November of 2003 and obtained 562 responses. The survey was confined to the United States and had 10 questions. There are some fascinating results; for instance in the area of online success, 24.7% indicated that monetary support is top priority, and then it followed the technical competency of the online instructors with 22.9%. In the area of pedagogical techniques to be used more widely online in the coming decade, 65.4% indicated that group problem solving and collaborative task was at the top followed by problem based learning with 58.1%.

Class Survey- We performed a survey in class in order to obtain some feedback about online teaching. These are some findings;

Question Number	question	Average
1	Have you taken an online course before?	10%
2	Have you used the internet to study and analyze mathematics?	30%
3	Was the pace of the course adequate?	78%
4	Was the delivery of the material by the instructor clear?	83%
5	Was the communication between you and the instructor clear during the online session?	81%
6	Was the online course more convenient for you than the classroom lecture?	56%
7	Was the testing adequate?	83%
8	Did you feel that you spent more time studying with the online class than the regular classroom lecture format?	41%
9	Did you feel that you spent more time doing homework with the online class than the regular classroom lecture format?	45%
10	Did you feel that you spent more time solving quizzes with the online class than the regular classroom lecture format?	63%
11	Did you feel that your study habits had to change, adapt, for the online class?	80%
12	How much change, adjustment, you had to make in question 11?	56%
13	Material for the lecture was provided before the online class. Did it help you understand the lecture more?	78%
14	Lectures online were archived. Did it help you learn and understand more?	70%
15	Having instant access to the lectures and lecture notes online helped you learn more?	69%
16	Note taking was reduced greatly when online lecture was delivered. Did it helped you understand the material, learn, more?	63%
17	Did you feel that you were engaged into the material and the learning process more so than in the classroom setting?	43%
18	Was the mathematics of the course delivered adequately?	67%
19	Would you take another mathematically intensive online course?	42%
20	Would you recommend a mathematically intensive online course to a friend?	52%
21	What is your overall rating of an online course like this?	68%



Even though questions 4, 5, 7, 11, and 13 stand out with about an average 80%, we feel that a great improvement needs to be made. Questions 18, 19, 20 and 21 apply to the overall course and the mathematics of it and the average was below 70%. This, in turn, indicates that our students, technology and instructor are not “linking” adequately.

**Conclusions**-Frustration was the common denominator in this online class. HOPE is the adjective that we have to have in order to succeed with online teaching. The premise that was used for years applies; not everyone is able or capable of taking an online course. The reasons; different learning styles, habits created for years in the classroom (change!), pace of the material, etc.

Students’ ability of self learning and self discipline is a major factor for an online class. These issues will be resolved after a few classes taken online. Notice that only 10% of the students surveyed had taken an online class before.

Online instruction has become a myth and in all honesty smart classrooms with classroom instruction are the best solution. Online learning should be used only for circumstances where there is no alternative; otherwise we should remain in the classroom environment where body language, emphasis, eye contact make the difference.

Finally the survey given in class was performed with a small population sample, 10 students. The purpose for the survey was to obtain feedback and adapt for the next cycle of online teaching. As mentioned before there is no reliable assessment that can give conclusive results, but this fact does not mean that we should stop trying. Furthermore, online teaching is here to stay.

Bonk [8] created a survey with industry to find strategies for online learning. The table below shows the results. It is clear that almost a complete project oriented in combination with simulations could be the way to follow.

	<b>Response Options</b>	<b>Response Rate %</b>
1	Authentic cases and scenario learning	63.04
2	Simulations or gaming	50.00
3	Virtual team collaboration and problem solving	46.52
4	Problem-based learning	42.17
5	Coaching or mentoring	39.13
6	Guided learning	37.39
7	Self-paced learning	34.35

**Instructional strategies to be more widely used in the coming decade**

## Bibliography

- [1] E. I. Allen and J. Seaman, *Growing by Degrees: Online Education in the United States, 2005* (Needham, Mass.: The Sloan Consortium, 2005).
- [2] C. J. Bonk, *The Perfect E-Storm: Emerging Technologies, Enhanced Pedagogy, Enormous Learner Demand, and Erased Budgets* (London: The Observatory on Borderless Higher Education, 2004); and K.-J. Kim, C. J. Bonk, and T. Zeng, "Surveying the Future of Workplace E-Learning: The Rise of Blending, Interactivity, and Authentic Learning," *E-Learn Magazine*, June 2005, <<http://www.elearnmag.org/subpage.cfm?section=research&article=5-1>> (accessed August 8, 2006).
- [3] Bruno Osorno, "Celt student engagement group report," California State University Northridge. May 2005
- [4] K. M. Partlow and W. J. Gibbs, "Indicators of Constructivist Principles in Internet-Based Courses," *Journal of Computing in Higher Education*, Vol. 14, No. 2, 2003, pp. 68–97.
- [5] M. T. Keeton, "Best Online Instructional Practices: Report of Phase I of an Ongoing Study," *Journal of Asynchronous Learning Networks*, Vol. 8, No. 2, 2004, pp. 75–100
- [6] C. J. Bonk, *Online Teaching in an Online World* (Bloomington, Ind.: CourseShare, 2001).
- [7] M. T. Keeton, "Best Online Instructional Practices: Report of Phase I of an Ongoing Study,"
- [8] The Future of Online Teaching and Learning in Higher Education: The Survey Says...  
By **Kyong-Jee Kim** and **Curtis J. Bonk**, Volume 29 Number 4, 2006.  
<http://www.educause.edu/apps/eq/eqm06/eqm0644.asp>
- [9] Cynthia Derochers, "CELT student engagement group," California State University Northridge, Spring semester 2005
- [10] Ray Landis, "Studying Engineering," Presentation and textbook, California State University Northridge. May 2005.
- [11] Bergen, Vittal, "Power Systems Analysis," Textbook, Prentice-Hall, 2<sup>nd</sup> Edition, 2000

- [12] "Growing by Degrees; Online Education in the United States, 2005" I. Elaine Allen, Jeff Seaman. Report sponsored by the Sloan Consortium, 2005
- [13] "The one Percent Solution," By Caro; A Twigg. Sequence: Volume 30, Number 6, 1995

**Bibliographical information**

Bruno Osorno is a professor of electrical and computer engineering at California State University Northridge. He has been teaching Electrical Engineering for over 25 years and his areas of interest are Electrical Power Systems and Energy. Currently He is in charge of the Electrical Power Systems program at CSUN. Electrical protection, electrical power systems simulations and applications and computer simulations of power electronics are current topics of research. He has published more than 20 technical papers. He has consulted for NASA-JPL, DWP and SCE. Also, he has over 8 years of professional experience in the area of industrial power systems with a global corporation.



## **Curricula for Using Waste Tires in Civil Engineering Applications**

DingXin Cheng, Assistant Professor of Civil Engineering, CSU, Chico  
Joel Arthur, Professor of Civil Engineering and Construction Management, CSU, Chico  
Albert M. Johnson, California Integrated Waste Management Board

The United States generates about 300 million waste tires each year. Approximately 40 million of these are generated in California alone. Waste tires stored in stockpiles can pose significant public health and environmental issues. Stockpiled waste tires provide an ideal breeding ground for mosquitoes and rodents, which can transmit diseases. Tires placed in stockpiles can ignite resulting in tire fires that are difficult to extinguish. Although the Environmental Protection Agency does not consider scrap tires as hazardous waste, tire fires release hazardous compounds which pollute the air, soil and water. Nationwide, millions of dollars has been spent to clean up tire fires.

### **BACKGROUND**

The California Integrated Waste Management Board (CIWMB) is tasked with diverting these tires from the waste stream to being recycled into useful products. Tire derived products possess some desirable engineering properties, especially for civil engineering applications, which is the fastest growing market for waste tire products. These applications include roadway construction, landfill applications, septic leach fields, gas and leachate collection systems, retaining walls, lightweight embankment fill, and vibration attenuation for railways.

Not all of the general public understands sustainability and utilizing waste tires as recycled products. Using recycled materials in real applications may face many challenges, especially if the knowledge of how to use the recycled materials such as waste tires has not been well disseminated. These challenges involve many different people, including engineers. Engineers may not have adequate knowledge about the physical properties, long term performance, design guidelines, and construction specifications. They may not want to take the risk of using recycled tires instead of conventional materials.

To promote sustainable and successful waste tire applications in civil engineering, a curriculum development and dissemination project was funded by CIWMB. Undergraduate engineering students are the future engineers; they need to learn how to utilize recycled materials such as waste tires in civil engineering applications as well as traditional materials such as steel, wood, and concrete. The primary purpose of this project was to produce and disseminate teaching materials that could be used in undergraduate civil engineering courses on utilizing waste tires in civil engineering applications.

## **OBJECTIVES**

The objectives of this research are to:

- synthesize the knowledge of utilizing waste tires in civil engineering applications
- develop effective teaching materials to educate university students about utilizing waste tire products in civil engineering
- promote sustainability by using waste tires in civil engineering applications through university education

The goal of this paper is to summarize the curricula of civil engineering applications of waste tire products and to make faculty aware of the existence of the course materials and resources developed on this project.

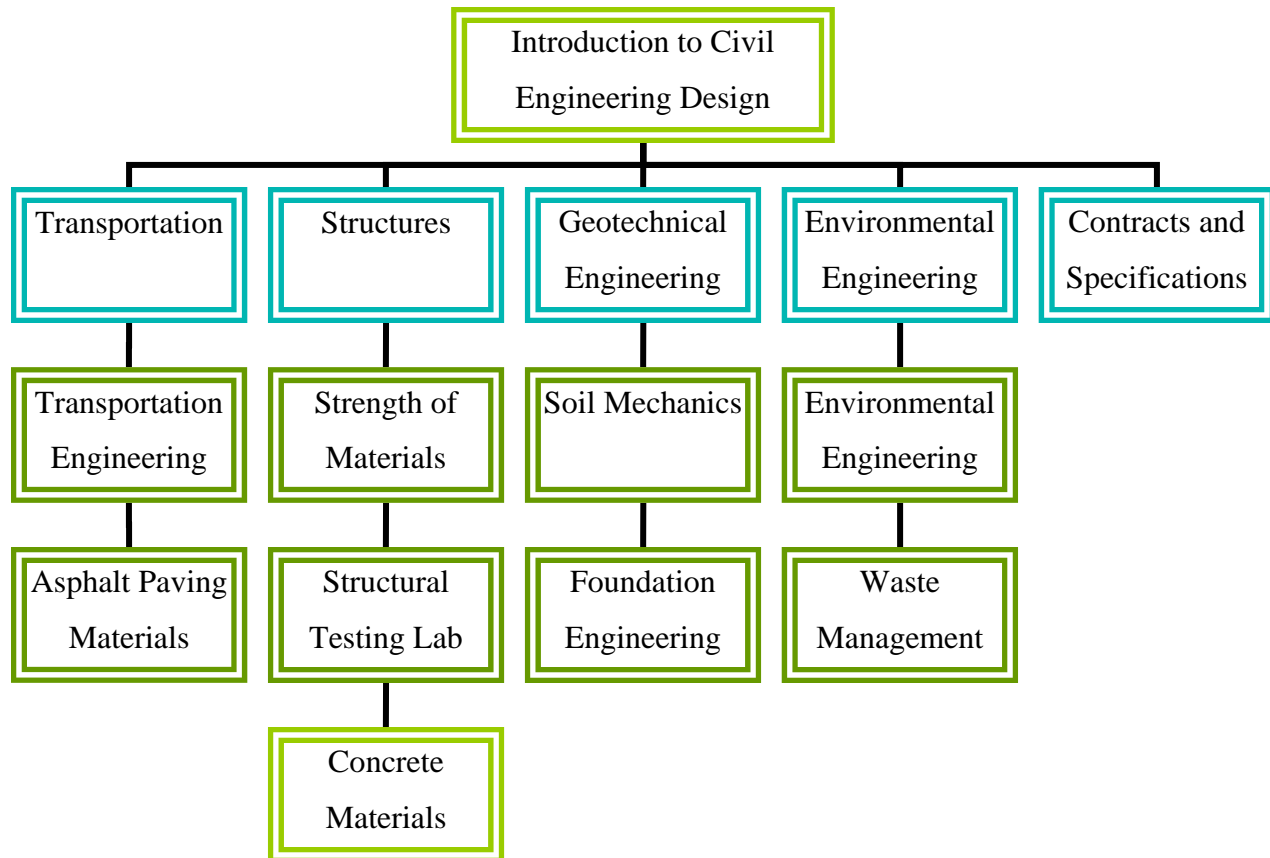
## **APPROACH AND PROPOSED CURRICULA**

Utilizing waste tires in civil engineering applications is a multi-disciplinary and complex subject. No single class currently available in civil engineering can cover all the aspects of it. At the beginning of the project, two different approaches were compared:

1. developing only one new class to include all aspects of waste tire applications
2. add teaching modules to different levels and related civil engineering classes

The second method was chosen because it is more flexible and can reach more students. It also gives students more opportunity to be exposed to waste tire educational materials.

Therefore, it was proposed to develop waste tire application teaching modules for a variety of civil engineering courses from freshman level to senior level. Each module contained one or more lectures. Figure 1 illustrates the courses that training modules were developed for.



**FIGURE 1. Roadmap for Waste Tire Applications in Civil Engineering Curricula**

By offering teaching modules for waste tire applications at different class levels, more students are reached than would be by a single elective class. By the end of university education, a student may be exposed to waste tire applications multiple times. It was deemed as a more effective way of teaching students about unconventional materials, such as waste tire derived materials.

### **CURRICULA DEVELOPMENT**

A series of course modules have been developed for a variety of undergraduate Civil Engineering courses, including the following areas:

- Introduction to Civil Engineering Design
- Mechanics of Materials and Materials Testing Laboratory
- Soil Mechanics and Foundation Engineering
- Contracts and Specifications
- Environmental Engineering
- Solid Waste Management
- Reinforced Concrete Design
- Transportation Engineering and Pavement Materials

The following sections describe the objectives, scope, and major components in each teaching module or class. For each module, assignments or evaluation worksheets were also developed.

Teaching modules are independent of each other. Each module emphasizes a different aspect of utilizing waste tire products in civil engineering applications. Some may discuss geotechnical engineering applications, while others may illustrate pavement material modification. In addition, they don't need to be offered all together. The format of the training materials can be flexible so professors or instructors can tailor the teaching module to their teaching needs as they please. Material from different lectures may be combined or edited as the instructor sees fit.

### **Introduction to Civil Engineering Design**

The goal of this lecture is to introduce university students to waste tire materials and give them an overview of utilizing waste tire products in a variety of types of civil engineering applications. It is important for students to understand the significance of utilizing recycled materials to preserve valuable natural resources. Students should also understand the significance of protecting the environment. They should also learn to promote healthy and sustainable development of our society.

The lecture introduces waste tire materials by discussing the potential negative environmental impacts if waste tire materials are not managed properly. In 1983, a tire fire burned about 7 million tires in Rhinehart, Virginia. The fire burned for nine months, polluting water with poisons, such as lead and arsenic. In 1998, a grass fire ignited an estimated 7 million tires at an unlicensed tire disposal facility in Tracy, California. It was extinguished after 26 months with water and foam. In September 1999, lightning ignited stockpiled tires in the town of Westley, California. The fire burned for three months. It took seven years to clean up the site and cost about 20 million dollars.

The lecture covers the benefits and challenges of using waste tire derived products in civil engineering and transportation applications. It discusses physical properties of waste tire derived aggregate (TDA). More importantly, it gives an overview of the major applications in civil engineering and transportation, including TDA as backfill materials for retaining walls and bridge abutments, lightweight fill for embankments, insulation layer for roadway base, vibration damping materials for rail lines, and rubberized hot mix asphalt for pavement. It also presents a roadmap of civil engineering classes that cover waste tire applications.

### **Mechanics of Materials**

This lecture mainly covers the physical properties of tire derived aggregates. TDA are pieces of shredded tires that are generally between 1 inch and 12 inches in largest dimension ( $L$ ). The common properties of TDA affecting engineering performance are: gradation, specific gravity, absorption capacity, compressibility, resilient modulus, time dependent settlement of TDA fills, shear strength, hydraulic conductivity, and thermal conductivity.

This lecture also covers a general model which is a combination of Maxwell and Kelvin models using spring and dashpot elements. The model can be used to analyze the energy dissipation and vibration mitigation characters of TDA. TDA has been used as a vibration damping material for a light rail line by Valley Transit Authority (VTA) in the Bay Area of California. The results

show that it is a very cost effective vibration attenuation material. The average vibration level of a light rail line has been reduced by 10 dB for the 30 to 250 Hz range comparing with a standard control section. This is a great noise reduction because dB is in log scale. The project also saved VTA approximately \$1 to \$2 million compared with a floating slab vibration mitigation technique.

### **Structural Testing Lab**

The lecture portion of the structural testing lab on TDA discusses the stress-strain relationship for TDA. This lecture introduces the common methods of measuring shear strength of granular materials, including soil, crumb rubber, and tire buffing. In the lab portion of the class students test the shear strength of crumb rubber using standard direct shear apparatus.

A literature review and comparison of shear strength parameters from many different sources were conducted. The shear strength of the TDA primarily depends on the: (a) size and shape of the tire rubber pieces, (b) density of packing, (c) magnitude of the compressive normal loading, (d) gradation, and (e) orientation of tire shreds.

### **Contracts and Specifications**

This lecture has two modules. One is on ASTM international standards; the other is for specifications on rubberized hot mix asphalt. A series of ASTM standards related to waste tire applications are covered. The major one is ASTM D6270, which has detailed definitions of tire rubber, material characterization, usage, construction practices, guideline for fills, and leachate etc (1). The lecture also provides students the necessary background on ASTM International.

The specification lecture starts with various types and aspects of specifications. As examples, standard specifications are illustrated using Caltrans standard specifications on RHMA – O (open graded rubberized hot mix asphalt) and RHMA – G (gap graded rubberized hot mix asphalt) (2).

### **Soil Mechanics**

Tire Derived Aggregate (TDA) has many unique physical properties that can be used in Geotechnical engineering. The in-place density of TDA ranges from 45 lb/ft<sup>3</sup> to 58 lb/ft<sup>3</sup>, which is about 1/3 the unit weight of soil. TDA can be used as a lightweight material to construct embankments on weak, compressible foundation soils. TDA has high permeability, more than 1 cm/sec, which can replace conventional aggregate to be used as gas collection media or leachate collection material. TDA is a good thermal insulation material, which has a thermal insulation 8 times greater than the gravel (1). In cold climates, placing a 6 to 12 inch tire shred layer under the road can prevent subgrade soils from freezing. In addition, excess water may be released when subgrade soils thaw in the spring. The high permeability of tire shreds allows water to drain freely from beneath the roads, preventing damage to road surfaces (3).

In the lecture material, the Dixon landing interchange project at the intersection of I-880 and Dixon Landing Road in the Bay Area is used as a case study to illustrate the design, construction, and cost benefit of the project (4). The embankment for the interchange needed to be constructed on top of about 30 feet of San Francisco bay mud, which is a highly compressible soil. It required using lightweight fill material for most fill sections to reduce the total settlement. For

most projects building on a soft clay type of soil, using TDA as a lightweight fill material is significantly cheaper than other alternatives. The Dixon Landing interchange project used 6,627 tons or 662,700 passenger tire equivalents (PTE) of TDA. The cost savings to Caltrans was \$447,000 compared to using standard lightweight aggregate for the project. When the purchase price of the TDA is subtracted, the cost savings was still \$230,000 (5).

Another case study for the soil mechanics class is using TDA as subgrade insulation for Witter Farm Road, Orono, Maine (3). Frost in this cold climate region can cause heaving of the road which can crack the asphalt, while the thawing weakens the road subbase leading to rutting of the gravel and cracking of the asphalt. From the test results, the frost depth was reduced from 55 inches in control section to about 30 inches in a TDA fill section (3).

The lecture also introduces using TDA for Marina Drive slope repair in Ukiah, CA (6). A road slide damaged the Marina Drive making it unusable. Using TDA as lightweight backfill material replacing typical backfill soil, less excavation is necessary and a more cost effective design can be utilized. The project used about 2,000 ton or 200,000 PTE tires (7).

### **Concrete Materials**

Rubber included concrete or rubberized concrete consists of mixing tire rubber into Portland cement concrete mix by replacing a portion of aggregate with crumb rubber. It changes the physical properties of concrete.

One of the most important factors to consider in using waste tire products in the production of concrete is the mix design. From the literature review shown in Table 1, the major mix design factors are proportions of crumb rubber by volume or by weight of mix, water-cement ratio, rubber type, and rubber content.

A fair amount of research has been done in using waste tire particles in Portland cement concrete. Although compressive strength and stiffness of concrete mixes decrease dramatically with increasing rubber content, the ductility, toughness, and tensile strain have been shown to increase with small amounts of rubber particles. Rubberized concrete may be more flexible and crack resistant for lightweight paving. It may provide vibration damping and sound transmission mitigation. It can be used for energy absorption due to dynamic force, such as earthquakes. It may also increase the freeze-thaw durability of concrete.

**TABLE 1. Summary of Rubberized Concrete Mix Designs from Literature**

<b>Author</b>	<b>Rubber Type</b>	<b>Rubber Content</b>	<b>Method of Mix Design</b>
Kaloush et. al. (8)	1mm Crumb Rubber	0, 50, 100, 150, 200, and 300 lb/cuyd	Replaced fine aggregate with crumb rubber by weight, increased w/c ratio
Fedroff et. al. (9)	Super fine powder	0, 10, 20, and 30%	By weight of cement in mix adjusted w/c ratio to get 3 to 5 inches of slump
Tantala et.al. (10)	Buff Rubber	5 and 10%	Replaced 5% and 10% of coarse aggregate with buff rubber by volume
Schimizze et.al. (11)	Fine/Coarse Reclaimed Rubber	5% of mix design by weight	Lowered both 1. fine aggregate and 2. fine and coarse aggregate to get 5% rubber by weight
Biel and Lee (12)	3/8" minus rubber droppings	0 to 90% in 15% increments	Replaced fine aggregate with crumb rubber by volume gave 0 to 25% rubber by volume in mix
Eldin et.al. (13)	Ground tire chips, fine crumb rubber	0,25,50,75,100% by volume	Test specimens replacing either coarse or fine aggregate

## Foundation Engineering

Lateral earth pressure is defined as the pressure exerted by a fill material on the wall of a structure like a retaining wall. It can be determined from the coefficients of lateral earth pressure, which are calculated by dividing horizontal stress by vertical stress. TDA can also reduce lateral earth pressure up to 50 percent compared to conventional soil backfill material. It also has good drainage properties to prevent water build up behind a wall. Therefore, TDA is a very good material as backfill for retaining walls and bridge abutments. It can reduce the design thickness of the wall and use less reinforcing steel (3).

This lecture introduces a full scale retaining wall testing project conducted at the University of Maine (3). The testing facility has four walls and a reinforced concrete foundation. The size of the testing facility is 16 ft. high by 15 ft. long by 14.7 ft. wide. The lateral earth pressure, horizontal displacement, interface friction between wall and TDA, were measured during the

test. It was found that the horizontal stress at rest for TDA is 45 percent less than that of conventional granular fill (14).

The lecture also introduces a case study of constructing of a real world retaining wall with TDA. Caltrans and the CIWMB have constructed a 300 linear foot retaining wall, called Wall 119, with TDA as lightweight backfill material along route 91, in Riverside, California. The retaining wall is 12 ft. tall, with 9.8 ft. of compacted TDA enclosed in a geotextile membrane. It has about 2 feet of soil cover. At designated locations, the forces were measured using pressure cells; the strains were measured with strain gauges; temperatures of tire shred materials were measured using temperature sensors; and the displacement of the wall was monitored by a tilt meter. The retaining project was very successful and it used 837 tons of TDA. The following picture shows the construction of the Wall 119.



**FIGURE 2. TDA as Backfill for Retaining Wall 119 in Riverside, CA (15)**

### **Environmental Engineering**

This lecture focuses on the environmental aspects of utilizing waste tires in civil engineering and transportation. First, it introduces the negative impact if waste tire materials are not recycled and managed properly. Then, it describes the engineering properties of TDA and rubberized asphalt. It shows the beneficial usage of waste tire materials in civil engineering applications, such as lightweight fill, landfill applications, vibration damping, and rubberized asphalt pavement.

Consequently, it addresses the environmental assessment research on using TDA and rubberized asphalt. Significant amounts of research, both laboratory evaluations and field tests, have been conducted on various environmental impacts. It provides students with the knowledge of what environmental factors that they should pay attention to when they use waste tires in civil engineering applications. Generally, recycled rubber derived from scrap tires is a safe recyclable material (16). It is important to recognize that the impact of scrap tires on the environment varies



according to the local water and soil conditions, especially pH values. It may not be safe to use when the pH is too high or too low (17).

### **Solid and Waste Management**

The construction of modern mechanized landfills requires large quantities of material which possess the same material properties as TDA. TDA is a free draining material and its permeability is greater than 1 centimeter per second. TDA can be used in many landfill applications such as operational layers, and gas collection systems.

Federal guidelines require landfills to employ a layer of material with a high void content to sit in between the waste and the impermeable layer of a landfill in order to contain leachate until removal. This layer is known as the operations or drainage layer. TDA is an excellent material for this application due to its high permeability. It is necessary that all leachate produced in a landfill is collected due to its toxic nature. Landfills have leachate collection systems which require a highly permeable material such as TDA.

Landfills are required to control and collect methane gas produced during the anaerobic digestion of organic wastes. The methane generated within the landfill tends to follow the path of least resistance. TDA is an excellent material for gas control systems due to its high permeability. Landfills use gas collection trenches to extract and capture the methane gas. Vertical trenches passing through the impermeable landfill cap allows methane gas to vent out of the landfill into a collection system. The vertical trench is composed of perforated pipe surrounded by TDA. This system allows the methane to vent out of the landfill into a collection system. Landfills also use trenchless gas collection systems. In these systems, methane is allowed to vent through the non permeable cap at the toe, located at the bottom of the lift. TDA is placed atop the toe to allow the methane to enter a perforated collection pipe. Due to TDA's high permeability and durability it is routinely used to protect and insulate parts of the collection systems. TDA is used to insulate horizontal collection pipes as well as protect gas well heads.

### **Transportation Engineering**

The goal of the transportation engineering lectures is to inform students of the history, benefits, limitations and practice of using asphalt rubber (AR) as a paving material. These lectures are divided into four modules, each dealing with a different aspect of asphalt rubber applications.

The students are first introduced to the history of using asphalt rubber as a paving material. Case studies of full scale AR overlay projects in California are presented. These studies outline the strategy of using AR as an overlay to repair existing distressed pavements, as well as discussing the design and results of the AR overlays. The benefits of using AR pavements as a replacement for conventional asphalt are also discussed. The second module introduces the structural design of AR pavements. A 2005 Caltrans study is referenced in this module to review the revised practices of using AR in new pavements as well as an overlay (18). Students are informed on the recommended design strategies for new pavements and overlays using AR. An overview of the revised practices for using AR in overlays and new pavement is also presented. This module also presents cost analysis comparing AR and conventional asphalt.

Students are introduced to the manufacturing and construction process of AR in the third module. The module discusses the general paving process with an emphasis on the different practices between AR and conventional asphalt. An overview of the manufacturing process informs students how AR is produced and also highlights the operational differences when dealing with AR such as the laydown and compaction temperatures for successful placement of AR. The last module of the lecture goes into detail about AR binder production, AR mix production, inspection of paving and troubleshooting. Some or all of these modules could be included in transportation and pavement engineering classes.

### **Asphalt Paving Materials**

This lecture consists of asphalt rubber (AR) binder design, the different types of AR mixes and cautions for using AR. The lecture defines the different types of asphalt rubber binders and discusses how each type is produced. Crumb Rubber Modifiers (CRM) are the form of waste tires added to the binder. The interaction between the CRM, the asphalt and the affecting factors are explained. When designing an AR blend, it is necessary to develop a binder profile which evaluates the compatibility, interaction, and stability between materials over a period of time.

The students are introduced to the most commonly used types of rubberized hot mix asphalt concrete, including Rubberized Hot Mix Asphalt – Gap graded (RHMA-G), Rubberized Hot Mix Asphalt – Open graded (RHMA-O), and Rubberized Hot Mix Asphalt – Open graded – High Binder content (RHMA-O-HB). The mix design, advantages, and standard specifications are described for each rubberized asphalt mixture type.

### **OUTCOMES**

Teaching materials for utilizing waste tire products in civil engineering applications have been developed for eleven different civil engineering courses. The teaching materials are available on a website hosted by CSU, Chico. All these lectures have been taught at the undergraduate level at California State University, Chico in a variety of civil engineering courses. Students have greatly improved their knowledge on utilizing waste tire products in civil engineering applications. They were able to demonstrate their knowledge of, and interest in waste tire applications through their term projects, lab reports, presentations, and homework assignments.

A website was created to store the teaching materials, which includes PowerPoint presentations, lecture notes, sample assignments and sample solutions and student work. The link for the website is:

<http://www.ecst.csuchico.edu/cp2c/dxcheng/Curricula/CIWMBEducation.php>

Professors and instructors can easily access the teaching materials by logging onto the website. If you log in as a professor, you will be able to use all of the teaching materials. The public can also access part of the teaching materials by logging in as a guest. Generally, they can only access the PDF versions of the presentations. A snapshot of the webpage for professors is shown as following figure.

[Logout](#)

Continue Education and Curricula of RAC and CE Application of Waste Tires

Class No	CLASS NAME	Power Point	PDF	Full Teaching Materials	Review Status
1	CIVL 131 Introduction to Civil Engineering Design				90%
2	CIVL 311-CMGT 345 Strength of Materials				90%
3	CIVL 312 Structural Testing Laboratory				90%
4	CIVL 402 Contract Spec and Technical Writing				90%
5	CIVL 411 Soil Mechanics				90%
6	CIVL 415 Reinforced Concrete Design				90%
7	CIVL 431 Environmental Engineering				90%
8	CIVL 441 Transportation Engineering				90%
9	CIVL 551 Foundation Engineering				90%
10	CIVL 598 Asphalt Paving Materials				90%

**FIGURE 3. Sample Webpage to Access Teaching Materials for Waste Tire Applications**

These course materials are available to be integrated into various courses in the undergraduate Civil Engineering curriculum and serve to introduce students to sustainable building practices and “green” construction.

## CONCLUSIONS

Each year, civil engineering applications and asphalt rubber combine together to consume more than 60 million waste tires. In order to promote the beneficial usage of waste tires in civil and transportation engineering, educational curricula, including a series of lectures for undergraduate courses were developed. The following conclusions can be drawn from the curricula development project:

- Waste tire applications cover a wide range of civil engineering areas, including geotechnical, environmental, structural, and transportation.

- Teaching modules or lecturing materials were developed to cover freshman level to senior level classes. The freshman class gives students an introduction and overview of waste tire products and their applications. Junior classes cover the material properties, testing, and standards. Senior classes cover the waste tire applications in civil and transportation engineering.
- Outcomes show that introduction of curricula in a variety of courses is an effective way to teach waste tire applications and can reach more students. Students have demonstrated a knowledge of and interest in the sustainable use of waste tire materials through their school work.

Students in civil engineering are the future engineers and their knowledge of waste tire applications will affect the sustainable usage of recycled materials such as waste tires. It was a good experience promoting the education of the sustainable usage of recycled waste tires in civil and transportation engineering by developing teaching materials. The education on the use of other recycled materials can follow a similar approach.

## REFERENCES

1. ASTM D 6270, Standard Practice for Use of Scrap Tires in Civil Engineering Applications, August 1998, reapproved 2004.
2. Caltrans Standard Specifications, Section 39, 2007.
3. Humphrey, D.N. Civil Engineering Applications Using Tire Derived Aggregate (TDA), CIWMB, Sacramento, 2003.
4. Tire Derived Aggregate as Embankment Fill, KENNEC, Inc. Website. <http://www.usetda.com/page.php?id=18>. Accessed July 30, 2008.
5. IT Corporation. Civil Engineering Application of TDA Dixon Landing Road On-Ramp Highway 880, Milpitas, California, June 2007.
6. Kenneec, Inc. Using Tire Derived Aggregate for Slope Stabilization. <http://usetda.com/page.php?id=2&ic=8>. Accessed July 30, 2008.
7. Kenneec, Inc. Project Manual and Specifications, Marina Drive Slide Repair, CR 266 at M.P. 0.63, Mendocino County, California, June 2007.
8. Kaloush, K.E., G.B. Way, and H. Zhu, Properties of Crumb Rubber Concrete, In *Transportation Research Record: Journal of the Transportation Research Board, No. 1914*, Transportation Research Board of the National Academies, Washington, D.C., 2005, pp. 8-14.

9. Fedroff, D., A. Shuaib, and S.Z. Savas, Mechanical Properties of Concrete with Ground Waste Tire Rubber, *Transportation Research Record 1532*, TRB, National Research Council, Washington, D.C., 1996, pp. 66-72.
10. Tantala, M.W., J.A. Lepore, and I Zandi, Quasi-Elastic Behavior of Rubber Included Concrete (RIC) Using Waste Rubber Tires. <http://www.seas.upenn.edu/~lepore/pwrptfiles/>. Accessed May 17 2002.
11. Schimizza, R.R., J.K. Nelson, S.N. Amirkhanian, and J.A. Murden, Use of Waste Rubber in Light-Duty Concrete Pavements, *Proceedings of the ASCE 3rd Materials Engineering Conference, Infrastructure: New Materials and Methods of Repair*, 1994, pp. 367–374.
12. Biel, T.D., and H. Lee. Use of Recycled Tire Rubbers in Concrete. *Infrastructure: New Materials and Methods of Repair*, November 1994, pp. 351-358.
13. Eldin, N.N., and A.B. Senouci. Observations on Rubberized Concrete Behavior, *Cement, Concrete and Aggregates*, Vol. 15, No. 1, June 1992, pp. 25-31.
14. Tweedie, J.J., D.N. Humphrey, and T.C. Sanford, Full-Scale Field Trials of Tire Shreds as Lightweight Retaining Wall Backfill Under At-Rest Conditions, *Transportation Research Record 1619*, Washington D.C., 1998, pp. 64-71.
15. Kennec, Inc. Tire Derived Aggregate as Retaining Wall Backfill, Wall 119, Riverside, CA, <http://www.usetda.com/page.php?id=12>. Accessed July 20, 2008.
16. Humphrey, D.N. and M. Swett. Literature Review of the Water Quality Effects of Tire Derived Aggregate and Rubber Modified Asphalt Pavement. Report for U.S. EPA, November 2006.
17. Liu, H.S., J.L. Mead, and R.S. Stacer. Environmental Impacts of Recycled Rubber in Light Fill Applications: Summary and Evaluation of Existing Literature. Chelsea Center for Recycling and Economic Development, University of Massachusetts, Technical Report #2, August 1998.
18. California Department of Transportation. Recommendations for Using RAC in New Pavements and for Structural Overlays. Sacramento, CA. December, 2005.

## Laboratory Projects Introduced in Teaching Manufacturing Processes Course

Jiancheng Liu, Ph.D.  
Department of Mechanical Engineering  
University of the Pacific  
3601 Pacific Ave., Stockton, CA 95211-0197  
jliu@pacific.edu

### Introduction

Mechanical engineering students should graduate with strong practical and interpersonal skills<sup>(1, 2)</sup>. Manufacturing Processes is a fundamental mechanical engineering course offered to junior students in engineering schools<sup>(3)</sup>. The primary objective of this course is to give students exposure to understanding of a range of modern manufacturing processes and practices. Students are expected to be able to select appropriate manufacturing processes and fabricate parts after completing the course. Normally, this course includes laboratory activities and fabrication projects. Students use different manufacturing equipment and make parts to get a “real” feeling of the manufacturing process. In the past two years, the author has introduced several innovative projects while teaching this course in University of the Pacific's School of Engineering and Computer Science. The goal of the projects is to inspire students' interest in the manufacturing engineering field. Students are expected to use the knowledge learned in this and other engineering courses such as Engineering Graphics and Materials Science to solve synthesis engineering problems. These projects are also aimed at helping students to better understand the fundamentals discussed in the classroom, making learning more enjoyable and improving student satisfaction. This paper will discuss these projects.

### Lego block design and fabrication project

The lego block design and fabrication project is a class-wide team project. One objective of this project is to provide students with an opportunity to work with other students in order to improve their communication and team work skills. Each student is required to design a block piece as shown in Figure 1. All blocks have identical outer dimensions. Students are allowed to design geometric features on two planes of the block. The block designs form mating patterns with those designed and fabricated by other students. The instructor specifies the assembly order of the blocks. During the design phase, students must complete their designs and pass them to other students in a scheduled time frame. Students have to interact with each other frequently to discuss the design details and negotiate necessary modifications. Students must completely understand each others' drawings and check for possible mismatches both in dimension and shape. Once each design is completed, the drawing will be arbitrarily given to another student for fabrication.

The blocks are machined using manual Bridgeport mills and NC machines. Through conducting this project, students improve their Solidworks modeling skills learned from Engineering Graphics class. Students also learn that they can be very creative in terms of design; however there could be many constraints in reality of part fabrication. A design must comply with the manufacturing equipment's capability and availability as well as manufacturing time and cost

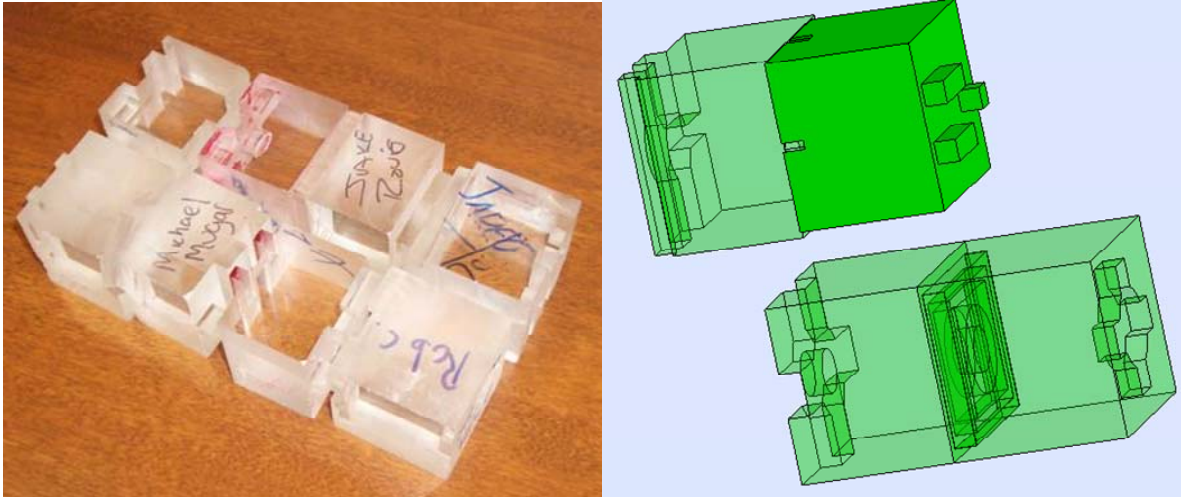


Figure 1 Examples of designed and fabricated lego blocks

requirements. Most importantly, students learn the importance of the team work and how to deal with project progress delays, iterative design modification caused by other team members and other challenges that arise over the course of a project. Figure 2 shows the design assembly and fabricated parts in the Fall 2008's class.

#### CNC programming and machining project

The CNC machine tool is one of the most important pieces of manufacturing equipment in industry. Almost all industrial products and every day consumer goods include components directly made using CNC machine tools. This project allows students to experience the operation of a modern NC machine. This activity obviously helps students to have a better understanding of the machine structure and component functions. This project also asks student to, using computer aided manufacturing (CAM) technology, create an NC program, which is used to drive the machine to move and act as desired. Using CAM to generate NC programming requires students to determine a machining strategy, operation sequence and cutting tools. Students must also decide the cutting conditions such as cutting speed, depth of cut, feed rate, and other parameters for each operation based on knowledge learned in classroom.

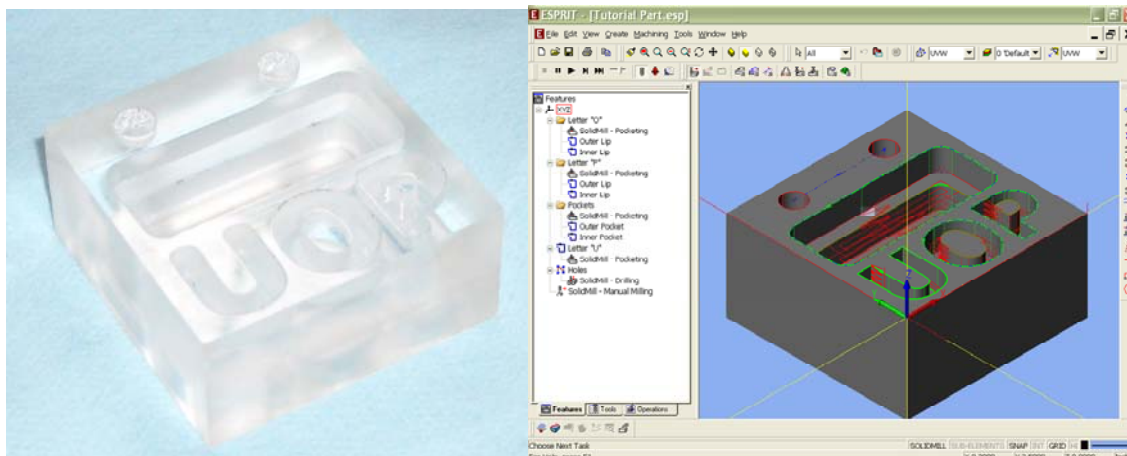


Figure 2 NC programming and machined part

This practice helps students to solidify their understanding of metal cutting theory. A commercial CAM system called “Esprit”, which was donated by the DP Technology Corporation, was used for this project. Students were impressed by the intelligent functions and cutting simulation embedded in this software package. Each student designs a part as shown in Figure 3 and then creates an NC program using Esprit. The NC programs are then uploaded to a CNC machine center (HAAS VF-1) for machining. Students machine the parts themselves under the supervision of the instructor, giving them hands-on experience with CNC machine tools. Through completing this project, students practice the entire part manufacturing cycle from design to manufacturing using the modern manufacturing technology. Students also experience the “joy of ownership” of the parts they make in the laboratory activities.

#### Part rapid prototyping project

Part rapid prototyping is a non-traditional part fabrication technology used to make product prototypes for design verification before mass production in industry. Using this technology, a part can be fabricated within hours. It is widely used in many engineering fields. This project requires students to design a part by following specifications determined by the instructor. Students then make the parts using a 3D printer purchased from Z-Corp.

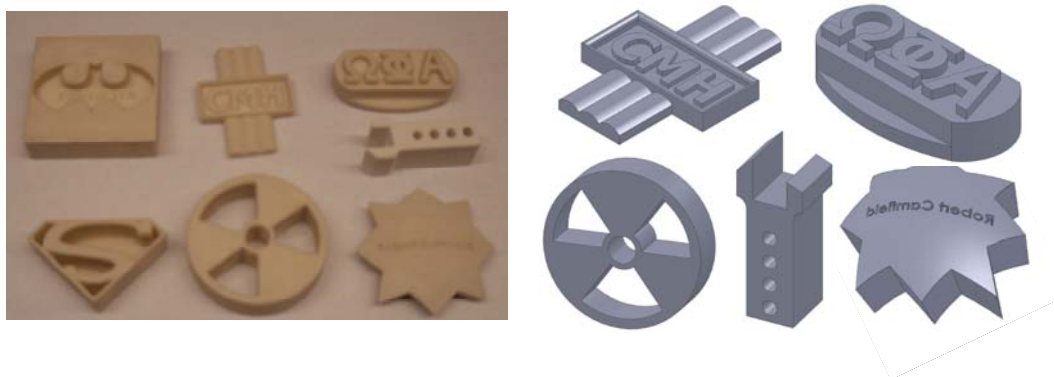


Figure 3 Examples of designed models and fabricated parts



### Concluding remarks

Several student projects introduced in teaching manufacturing processes course were shared in this paper. These projects provided students with an integrated environment to work as a team and apply the knowledge and skills learned from other courses to solve engineering problems. These projects improved student's learning and satisfaction.

### References

- 1) Liu, J., (2005). "Digital Engineering Technology in Machine Tool ." Keynote Speech for CIRP/SME SME/CIRP International Conference on Manufacturing Engineering Education, June 22-25, California.
- 2) Liu, J. (2008), Brown, A, "Enhancing Machine Design Course through Introducing Design and Analysis Projects," Proceedings of 2008 ASEE PSW conference, March 27th~ 28th 2008, Arizona.
- 3) Kalpakjian, S and Schmid, R (2001), "Manufacturing Engineering and Technology, 2nd , Prentice Hall(ISBN 0-201-36131-0)

### Author's Biography

Dr. Liu has published more than 70 technical journals and conference papers. He was awarded four patents. His research and teaching interest includes manufacturing system and processes, machine design and analysis, and CAM/CAE.

## ***CIBRED via CIERRA for Educating the Next Generation of Engineers***

Thomas MacCalla, Ed.D., NUCRI, Jacqueline Caesar, Ph.D., and Michael Maxwell, Ph. D., NUCRI and National University College of Letters and Science, VBI Project Teachers Shay Vanderlaan, Sandra Valencia, Terena Henry, and Matt Leader

### **Abstract**

The National Science Foundation CI-TEAM (*Cyber-Infrastructure Training, Education, Advancement, and Mentoring for Our 21st Century Workforce*) awarded the Virginia Bioinformatics Institute at Virginia Tech University a two-year Implementation grant for a CIBRED\* (*Cyber-Infrastructure for Biological Researchers, Educators and Development*) project. The collaborative undertaking involves partnerships with scientists, researchers, secondary school teachers, and college faculty from several institutions nationwide. It is designed to build an enriching and engaging curriculum development and deployment program that would prepare undergraduate, middle and high school students for research environments where cyberinfrastructure systems, tools and services are used effectively to fuel a knowledge-based economy.

The deployment phase is a CIERRA for STEM field careers and 21st century education and workforce component. This two-pronged approach could be considered as K-12 educational, outreach, and training (EOT) stimulus and renewal strategy. CIERRA stands for Cyber-Infrastructure Education Recruitment, Retention, Advancement), while STEM stands for Science, Technology, Engineering, Mathematics. EOT is the roadmap for preparing the next generation of engineers and future scientists in the global knowledge economy. This paper highlights the E in STEM referencing a Team Science approach to preparing the next generation of engineers, technicians, researchers, and future scientists. CIBRED and CIERRA are used here as a way to show how this collaborative, project-centric bioinformatics initiative can contribute to the development of an educational pipeline to prepare in/out-of-school youth with 21st century workforce skills and foster innovation and interdisciplinary practice. The product and the processes are applicable to K-12 engineering education

---

\*CIBRED is funded by NSF award OCI-0753375 to O.Crasta

## **Introduction**

Russell A. Hulse noted in his Nobel Laureate Paper, “Preparing K-12 Students for the New Interdisciplinary World of Science” that attitudes and habits are life skills formed during the early growing-up years and that all students need to acquire basic factual and procedural knowledge. He also argued that all students should have an understanding of science and that we should develop a capacity for interdisciplinary work while fostering the excitement of scientific research.

*For K-12, we are talking about first steps toward this goal, which certainly involves enhanced exposure to a broad range of fundamental scientific content as well as conveying the excitement of scientific research. Beyond this, however, is the need to lay a foundation in such overarching subjects as the varied to good scientific process, systematic analysis, and problem-solving, complemented by development of good communication skills and the ability to work well in collaborative groups. (1)*

Hulse’s insightful observations reinforce today’s clarion call for Science, Technology, Engineering, and Mathematics (STEM) educators to facilitate and encourage collaboration in engineering education, math, and science. They also underscore the alarm sounded by the National Science Teachers Association (2) in its recent national survey and substantiate the findings of the American Society of Engineering Education in its 2004 report on *Engineering in the K-12 Classroom*, “Current Practice Analysis and Guidelines for the Future” (3) What we are suggesting here is that the project-centric approach introduced in the NSF-sponsored Virginia Bioinformatics Institute’s CIBRED Project, coupled with the National University Community Research Institute’s companion CIERRA (*Cyber-Infrastructure, Recruitment, Retention, Advancement*) initiative and distributed learning efforts, can add to the promise.

The purpose of this paper is to introduce a multi-level, interdisciplinary education, outreach and training approach to integrating CIBRED (*Cyber-Infrastructure into curriculum design, development, and delivery for Biological Researchers, Educators, and Developers*) and contribute to the preparation of future scientist and engineers in our global knowledge economy. CIBRED’s mission is to empower current researchers and the future workforce with specific CI tools and an interdisciplinary work environment that will enable them to generate new knowledge with a focus on the problem that transcends the boundaries of different disciplines and technologies needed to achieve their scientific objectives. The basis for the trans-disciplinary enterprise is the National Science Foundation’s CI-TEAM program, which is designed to promote the acquisition of knowledge and the requisite skills needed to create, advance and exploit the potential of cyberinfrastructure.

The long term objective of CIBRED is to make state-of-the-art science and engineering research more accessible to all by providing training, education, and mentoring to meet the needs of current and future scientists. Such an objective could be applicable to the future of engineering education. CIBRED’s target audience is high school and college STEM students STEM and its complementary agenda is the introduction of a CIERRA education, outreach and training strategy for broadening participation and the applicant pool in the

STEM fields. Nonetheless, this dual thrust is tantamount to a K-12 educational stimulus and renewal strategy and could make an important contribution to the education of the next generation of engineers. <https://cibred.vbi.vt.edu/drupal/>



### **The Status of STEM**

The STEM education issue is well-documented. A 2008 Congressional Research Report stated that a large majority of secondary school students fail to reach proficiency in math and science, and many are taught by teachers lacking adequate subject matter knowledge. It also noted that in an assessment of 15-year old students, the United States ranked 28<sup>th</sup> in math literacy, 24<sup>th</sup> in science literacy, and 20<sup>th</sup> among all nations in the proportion of 24 year olds who earned degrees in natural science or engineering. (3) The good news is that educators, business and industry leaders, professional groups, and policy makers are responding and results from the National Assessment of Educational Progress report steady improvement in math and science and recognize the interdisciplinary approach is critical for taking the nation's STEM performance to the next level

<http://www.edweek.org/ew/articles/2008/03/27/30intro.h27.html>. Moreover, several major U.S. companies are investing large amounts of money into schools and colleges to support and strengthen STEM education initiatives. Likewise, the American Society of Engineering Education has exerted leadership with its one-stop ASEE EngineeringK12 Center that identifies and makes available effective engineering education resources to the K-12 community. A collection of STEM education resources also are provided through web portals, websites, and individual digital resources through the National Science Digital Library (<http://nsdl.org/collection/stem-education/>) and the California Space Authority's online searchable database called the STEM Inventory and Talent Development program to accelerate development of a highly-skilled 21<sup>st</sup> century talent pool and support for a continuum of math, science, engineering education, and lifelong learning.

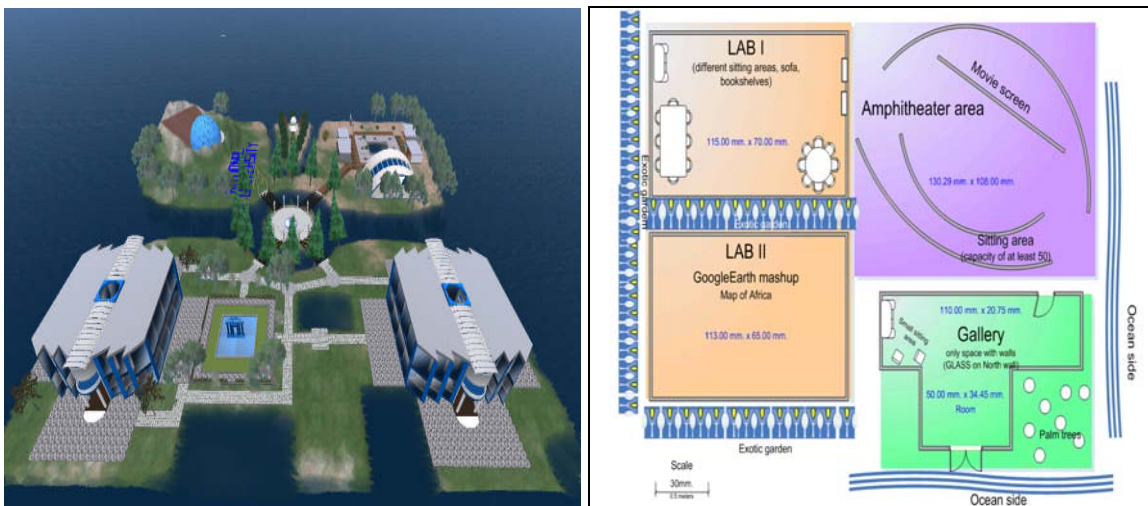
<http://www.militaryconnection.com/events/pdfs/CSA-STEM-Inventory.pdf>

The CIERRA initiative is an educational outreach and training and resource network for Science, Technology, Engineering, and Mathematics (STEM) of the National University Community Research Institute (NUCRI) in San Diego (<http://www.nucris.nu.edu>) More specifically, CIERRA is designed to identify, engage, and develop middle and high school students and teachers for collaborative learning and related workforce development.. Central

to its EOT strategy is the K-12 professional development of teachers and community practitioners through a blended Professional Development Extension (PDX) Online series of familiarization/enrichment courses, student engagement, and project-based service learning programs. CIERRA participants begin by taking a GLOBE K-12 Science Education onsite/online program and continue with such blended e-Learning digital media skill-building courses as “Digital Storytelling,” “Animation in the Science Classroom” and selected “Introduction to STEM” courses.

CIERRA was a response to the need for an education and workforce development pipeline in the STEM fields. It started with serving charter school teachers and underserved middle/high school students in the Los Angeles Basin. The program soon expanded to include teachers and students at the residential Job Corps Center in San Diego and the highly touted High Tech High charter school. These classroom teachers and counselors then were encouraged to participate in related STEM projects associated with NUCRI. They conduct experiential service learning projects take, PDX Online/Onsite courses, and participate in digital media and learning activities, such as VBIland in CyberEdWorld.

CyberEdWorld is a private 3D immersive, multiplayer learning environment designed to foster interdisciplinary teaching, learning and team research. It resides on the Second Life Grid and enables participants in different environments and locations to interact and collaborate in real time in 3D space. The VBIland layout provides a digital media learning environment that simulates real world space and stimulates creativity. The private virtual island can accommodate interactive science labs, a gallery, information exchange lounges, library resource kiosks, work rooms for a collaboration, community areas, etc.



A special feature of the CIERRA initiative is not only to broaden participation in the STEM fields, but also encourage teachers to become STEM master teachers in the process by becoming National Board Certified Teachers (NBCT) as CIERRA Champions. The NBCT awards are a symbol of professional teaching excellence and are recognized by the National Board for Professional Teaching Standards and the National Research Council, which attest to the teachers meeting rigorous standards through intensive study, expert evaluation, self-assessment and peer review.

## **CI-TEAM and CIBRED**

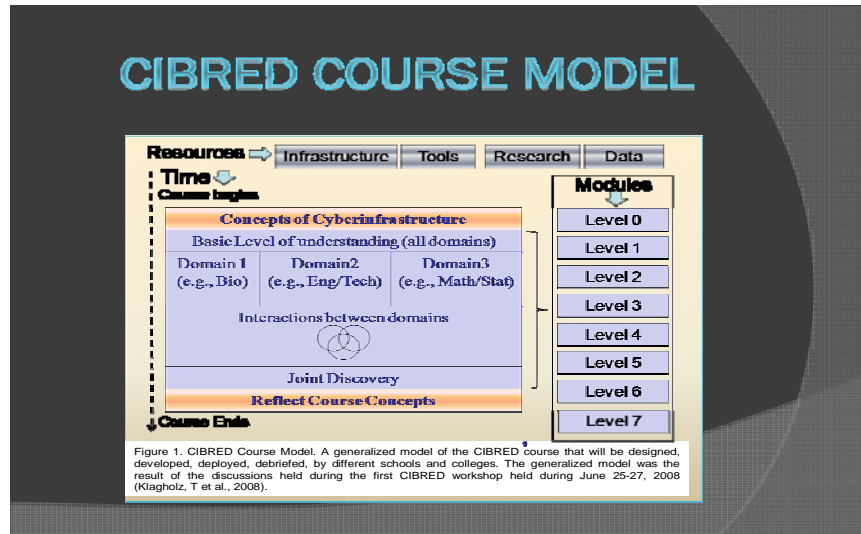
Currently, Virginia Bioinformatics Institute at Virginia Tech University (<http://www.vbi.vt.edu>) is conducting a two-year, NSF-sponsored Cyber-Infrastructure Training, Education, Advancement, and Mentoring for Our 21st Century Workforce (CI-TEAM) Implementation project for Biological Researchers, Educators, and Developers (CIBRED). Two interdependent goals focus on leveraging:

- effective Cyberinfrastructure (CI) collaborations with current researchers to use and advance CI
- the research data, context and experience for use by the educators in training the future workforce using a project-centric bio-informatics course to broaden participation.

The collaborative project-centric, team science curriculum/module design, development, and deployment effort involves middle/high school teachers in Virginia, California, and New Jersey and faculty at National University, Howard University, Hampton University, and Stockton State College in New Jersey. Individually and collectively they are putting the pieces together, “stand-alone” or “plug in” enrichment modules for the interdisciplinary biology and life science classroom. The intent is to engage and prepare students and teachers to be in research environments where CI systems, tools, and services are utilized effectively to fuel the knowledgebase economy. The process builds upon the CI-TEAM Demonstration project developed by the Virginia Bioinformatics Institute in collaboration with Galileo Magnet High School and Bluefield State College. The goal of the high school Microbial Genomics class was to study pathogens from a bioinformatics perspective.

CIBRED research data and results from the current Implementation collaborations will be leveraged towards the development, modification, implementation and dissemination of a new, multidisciplinary course in bioinformatics and multi-level STEM instruction with a project-based learning paradigm. The objective is to stimulate interaction and participation and embed the cyberinfrastructure concept through role playing activities and presentation. Roles are developed around professionals that would come into play should an outbreak occur (i.e. Center for Disease Control specialists, researchers involved in vaccine and/or drug development, hospital physicians, microbiologists, and evolutionary biologists)

Illustrated below is a CIBRED Course Model which depicts cyberinfrastructure concepts, related course concepts, and begins at Level Zero. The curriculum focus is on collaborative learning and problem-solving to generate solutions that transcend discipline-specific boundaries. Instruction is provided in flexible teaching modules to promote project-based learning in different delivery formats. The process emphasizes: 1) Teaching bioinformatics through scenarios focused on key pathogens, 2) Cutting edge data and techniques centered on real problems, and 3) the use of a cyberinfrastructure approach to problem solving.



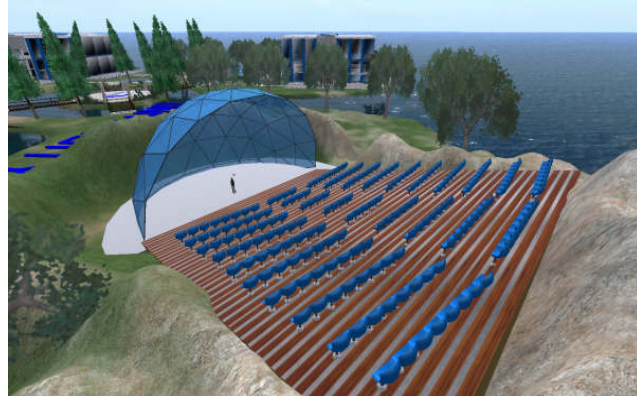
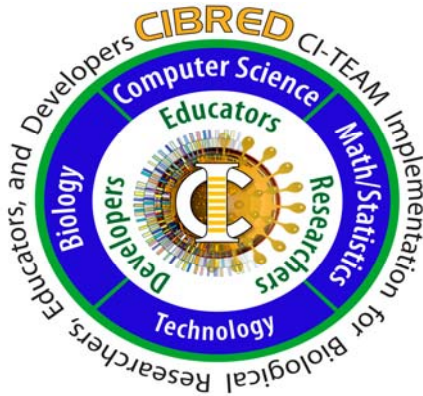
The CIERRA teachers developed a Crime Scene Investigation (CSI) approach to building a stand-alone curriculum module, and created a Viral Scene Investigation (VSI) case study called the “Ebola Virus Module.” They presented an investigative scenario to engage three different groups (6-9) of students to identify a viral outbreak, track the spread of the virus, find the cause, and develop a drug to stop/control recurrent infection. The Scenario was presented as follows:

*World Health Organization (WHO) officials reported 95 cases of an outbreak of disease in the Cuvette-Quest region of the Republic of Congo, resulting in 77 deaths so far. WHO has also identified 149 more people who had been in contact with patients suffering from the highly contagious disease. The first ten patients were admitted to a local hospital. One patient was admitted complaining of flu-like symptoms and continued to rapidly digress. Five more patients were admitted with headaches, intense muscle pain, and diarrhea resulting in internal bleeding and death.*

*Two adolescent patients were admitted after severe rashes developed. Two other patients were re-admitted after continued complaints of dehydration and headaches. Fluid samples were taken from all ten patients and given to the microbiologists for examination. The same family of RNA viruses called Filoviridae were detected in each patient. WHO and the Center for Disease Control (CDC) were called. Upon hearing of the “outbreak,” representatives from a major pharmaceutical company called to offer assistance. They are working with biologists at the area university on a new medicine that could help the case. The CDC workers arrived on the scene and took patient background information.*

Teachers and students have access to large amounts of pertinent data and have contact with researchers. It is felt that a similar approach to curriculum development could be used for K-12 engineering education.

As mentioned earlier, the CIERRA group of teachers developed a 3D virtual lab and learning environment in Second Life for engaging students and other teachers in related exploration, experimentation and knowledge sharing. They were encouraged by knowing that Virtual Labs also are being used by the Center for Disease Control (CDC) and the National Aeronautics and Space Administration (NASA). The result was to secure and build a virtual teaching and learning environment in CyberEdWorld, now referred to as VBIsland. The middle and high school CIBRED teachers would be the classroom content experts, NUCRI digital media fellows and faculty associates would serve as SL multimedia consultants, along with a very experience virtual space builder.



The Second Life scene accommodates engineering practice as well as education. As Pam Broviak, PE, (aka Pam Renoir in SL) who is the Public Works Director and City Engineer in La Salle, Illinois, said in *Second Life: A Virtual Universe for Real Engineering*, by applying SL building tools, engineers are facilitating a paradigm shift in computer-aided design. Broviak used the SL environment in her engineering practice to design plumbing systems and illustrate how the virtual space facilitates engineering design while reconfiguring the piping in a residential building to prevent sewage backup. She also used the venue to demonstrate “Real life engineering with Second Life tools.



**Pam Renoir & TEEEX Clary on Public Works Island**

[http://www.theseventhsun.com/0308\\_publicWorks.htm](http://www.theseventhsun.com/0308_publicWorks.htm)



Of particular note is the Second Life presence of the Institute of Electrical and Electronics Engineers (IEEE) who created a virtual environment to support its organization’s needs across two islands. <http://www.ieee.org/web/volunteers/tab/secondlife/index.html>





### **Cyberinfrastructure and Interdisciplinary Practice**

As we know the term Cyberinfrastructure refers to the integration, coordination, and deployment of information technology and human resources to support modern science and engineering problems. CI includes hardware (computers, data storage, networks, visualization facilities, and scientific instruments) and software to provide the technology “fabric” and infrastructure foundation for modern science. We maximize the use of CI by engaging in team science or working together across disciplines. In the CIBRED project we broaden participation in STEM by beginning at “level zero” and practice interdisciplinarity and extend the reach via transdisciplinary team science, which integrates discipline-specific theories, concepts, and methods into a research environment that transcends academic discipline boundaries. In 2006, Virginia Tech University became the first U.S. higher education institution to offer an integrative STEM Education graduate program to develop 21<sup>st</sup> century K-16 STEM educators, leaders, scholars, and researchers to promote trans-disciplinarity (<http://teched.vt.edu/TE/STEM.html>)

Another part of the framework is the digital media and learning environment or Cyberlearning space, which is supported by networked computing. The National Science Foundation’s 2008 Task Force Report on *Fostering Learning in the Networked World* (8) envisioned a “Cyberlearning” noted that content is no longer limited to books, filmstrips, and videos associated with classroom instruction and that networked content today provides a rich immersive learning environment that incorporates accessible data using colorful visualizations, animated graphics, and interactive application (8). The creation of *VBIsland* in NUCRI’s *CyberEdWorld*, reflects NSF’s virtual learning vision and advances the notion of a collaborative work environment for an interdisciplinary education, outreach and training pipeline for the next generation scientists, engineers, and 21<sup>st</sup> century workforce.

The Institute also is developing a complementary MAGNA (*Multimedia Access Grid Networking, Achievement*) Charter School Resource Network in *CyberEdWorld* for student engagement, discovery, and knowledge-sharing. It is a networked world that will focus on a motivational paradigm where many can contribute collaboratively to shaping educational reform and promoting student achievement. The overarching goal is to shift away from the more traditional *one-to-many* teaching to a *many-to-many* approach. The MAGNA Charter also includes a 3D immersive learning space with a number of virtual rooms for object-based learning, events-based learning, and theme-based learning. It is designed to be a

gateway to game spaces where geographically-dispersed and diverse students from public charter high schools can connect with inquisitive learners everywhere. They also can extend their reach and enlist others to broadening participation in the STEM fields.

The developmental resource network is aligned with a “Trilogy for Student Success” model (9), which focuses on *Engagement, Capacity, and Continuity*.” It addresses the persistent problems of disengagement, diversity, and low academic achievement while fostering educational empowerment for the future of science, quantitative disciplines and the 21<sup>st</sup> century knowledge economy. “Trilogy” defines “Engagement” as that which draws the learner to study and “Capacity” as the fundamental knowledge needed to advance to more advanced levels of learning. “Continuity” is the pathway that offers the necessary resources for advancement. Access is vital to Continuity, and all three are interdependent.

### **NxGen Target Audience and Implications for Engineering Education**

A key question to be considered is “How can these innovative approaches contribute to educating the next generation of engineers?” We know that much is being done to address STEM education pipeline issues, but we know little about who is getting the message, and how we can determine the effectiveness of our collective effort. One place to start is to identify and link one-stop STEM resource centers already in place and development a community outreach, education, and training informatics systems to distribute their treasury of information. The Institute of Electrical and Electronics Engineers’(IEEE) Pre-University Education website and related educational activities,

<http://www.ieee.org/web/education/preuniversity/home.html>, ASEE’s EngineeringK-12 Center, and the hands-on learning DTEACH (*Design Technology and Engineering for America’s Children*) Program at the University of Texas at Austin are starting points <http://www.engr.utexas.edu/dteach/>

The National Science Digital Library <http://nsdl.org/> and the Texas-based Infinity Project, [http://www.infinity-project.org/contact/contact\\_idx.html](http://www.infinity-project.org/contact/contact_idx.html) which was created by a world-class team of university faculty, high school teachers, working engineers, and leading researchers, the University of Virginia’s Middle School Engineering Education Initiative and the California Space Authority’s STEM Inventory, also can serve as pivotal nodes. Moreover, we should not just think in terms of information and knowledge sharing, but also new skill development, as underscored in a 2006 *Educause Quarterly* web article “Connecting the Digital Dots: Literacy of the 21<sup>st</sup> Century”

<http://connect.educause.edu/Library/EDUCAUSE+Quarterly/ConnectingtheDigitalDotsL/39969?time=1235597927> and the Metiri Group’s “enGauge 21<sup>st</sup> Century Skills” website. <http://www.metiri.com/features.html>

Another important question is: “Who and broad is our audience, including youth in-and-out of school, prospective STEM teachers, ethnic minorities, women and those students with special needs. In California approximately twenty-five percent of its 127,292 high school youth were dropouts, with African American and Latino students leaving at a much higher rate than any other ethnic group. These youth represent a potentially untapped pool.

<http://www.sfgate.com/cgi-bin/article.cgi?f=/c/a/2008/07/16/BAS311QATL.DTL>

## **Conclusion**

In his “The Future of Engineering, Science & Mathematics: Who Will Lead?” Remarks on the occasion of Harvey Mudd College’s 50<sup>th</sup> Anniversary Celebration, National Science Foundation Director Arden Bennett Jr. stated:

*In this knowledge economy, intellectual and human capital, infrastructure, and R&D investment are more important than the availability of raw materials.... The rapid spread of computer and information tools compels us to join hands across borders and disciplines. Communications and collaboration hasten the transformation of knowledge into products, processes, and services. In their wake, they produce jobs and wealth and improve the quality of life worldwide.*

<http://www.pkal.org/documents/2007%20Summer%20Institute%20Notebook.pdf>

The challenge is still with us and an answer to Arden Bennett’s question is: What can we do together? *and* When can we get started?

## **Acknowledgement**

The authors acknowledge contributions by various CIBRED participants, especially Oswald Crasta and Daphne Rainey from the Virginia Bioinformatics Institute, Arun K. Datta from the National University Community Research Institute, and VBIIsland Consultants James Jaurez from National University and Ana Boa Ventura, University of Texas, Austin. CIBRED is conducted with NSF funding to O. Crasta (OCI-0753375).

## **Selected Reference**

1. Husle, Russell A. Nobel Laureate Papers, “Preparing K-12 Students for the Interdisciplinary World of Science.” University of Texas at Dallas, 2006 (PDF)  
<http://www.ebmonline.org/cgi/content/full/231/7/1192>
2. National Science Teachers Association. “National Survey Depicts Status of K-12 Science and Math Education” Arlington, Virginia: NSTA News Digest, 2002  
<http://www.nsta.org/publications/news/story.aspx?id=46422>
3. Congressional Research Reports for the People. Science, Technology, Engineering, and Mathematics (STEM) Education: Background, Federal Policy, and Legislative Action. Washington, D.C.: Center for Democracy and technology, March 21, 2008.  
<http://openrcs.com/document/RL33434/>
4. The National Science Foundation. *Fostering Learning in the Networked World, The Cyberlearning Opportunity and Challenge, A 21<sup>st</sup> Century Agenda* for the National Science Foundation. Report of the NSF Task Force on Cyberlearning. Arlington, Virginia. June 24, 2008
6. Jolly, Eric J., Campbell, Patricia B., Perlman, Lesley. *Engagement, Capacity, and Continuity: Trilogy for Student Success*. GE Foundation, September 2004

## Bio-molecular Engineering Verified by High Sensitivity Detection

Claudia Lee<sup>1</sup>, Andrew Zepfel<sup>2</sup>, Nina Timberlake<sup>3</sup>, Larry Grill<sup>4</sup>, Sean Gallagher<sup>1</sup>

<sup>1</sup>UVP, LLC

<sup>2</sup>Claremont McKenna College

<sup>3</sup>Scripps College

<sup>4</sup>Pitzer College

### Abstract

An interdisciplinary, industry-academic collaboration was conducted to aid students at the Pitzer College Vaccine Development Institute and the Claremont Colleges to study the progression of Tobacco Mosaic Virus (TMV) on plants. Symptoms of the virus, including discoloration and mottling, usually takes weeks to develop. The students genetically inserted the gene for green fluorescent protein (GFP) into the virus genome. The genetic modification allows the viral infection to be detected within a few days via fluorescent imaging. The detection of the fluorescence was aided by UVP, LLC. Fluorescent images of a tobacco relative (*Nicotiana benthamiana*) agroinfected with GFP-TMV was captured daily using a macro imaging system to document the intensity and area of the viral expression. The quantitative data is used to observe the movement and expression of the virus under various conditions and when changes are made to the viral gene sequences. Students were exposed to the technical aspects of fluorescence imaging besides being able to rapidly verify their biological work.

### Introduction

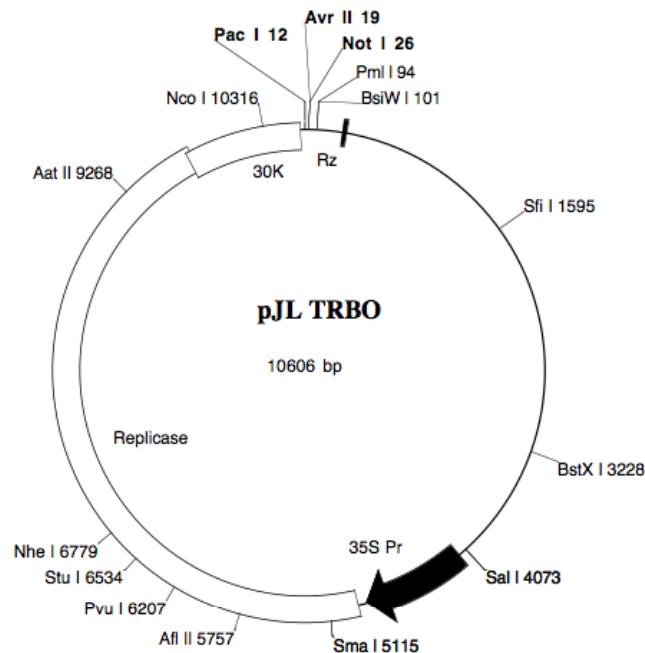
The Vaccine Development Institute at Pitzer College aims to produce low cost vaccines by genetically engineering Tobacco Mosaic Virus to express immunogenic epitopes on the surface of the viral coat protein. Vaccines and therapeutic drugs produced in this manner have previously been shown to be highly efficient in eliciting an immune response (Kohl et al., 2006). Moreover, this production method is significantly faster and less costly than other more traditional methods involving bacterial or mammalian cells (Grill, Palmer & Pogue, 2005).

TMV is a rod-shaped RNA virus that infects members of the *Solanaceae* family of plants, which includes tobacco, tomatoes, and potatoes. The virus causes mottling and discoloration of the leaves, but is not fatal to the infected plant. These symptoms appear in new growth and often take weeks to become clearly apparent. In order to more quickly detect and quantify the spread of TMV through a plant, the virus was tagged with GFP and visualized using an UVP BioSpectrum<sup>®</sup> Imaging System. The GFP tag allows for detection of the virus in plant tissue as early as two days post-infection, and for monitoring the spread of the virus through the plant. Early detection confirms the success of cloning procedures and the correct functioning of the virus.

## Method

### Engineering the TMV genome

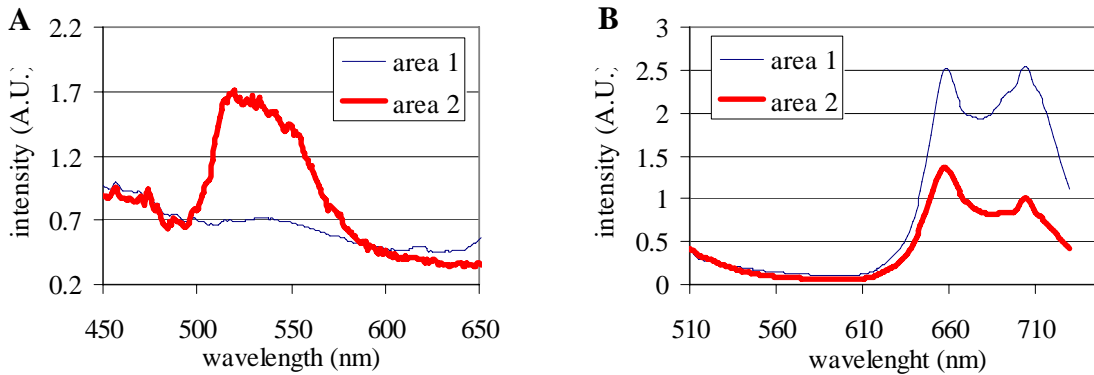
GFP was enzymatically inserted into the PacI-AvrII-NotI multiple cloning site of the pJL TRBO vector (Figure 1). The pJL TRBO vector, as previously described by Lindbo (2007), was designed to maximize production of the inserted protein. It contains the entire TMV genome, except the gene encoding the viral coat protein, bordered by 25-bp repeat sequences, which enable the incorporation of the viral genes into the plant genome after infection. Competent *Agrobacterium tumefaciens* cells were transformed by heat-shocking with the TRBO-GFP construct. *A. tumefaciens* is a plant bacterium that utilizes a tumor-inducing (Ti) plasmid to transfer genes directly into the host's genome. After transformation, the bacteria can be cultured and injected directly into the leaves of *Nicotiana benthamiana* plants. Plants are maintained in a controlled environment at 27°C with 16 hours of light per day. GFP expression in the plant tissue is visible 2 days post-infection (dpi).



**Figure 1.** pJL TRBO vector with PacI-AvrII-NotI multiple cloning site. Replicase and 30K protein are part of the TMV genome. TMV coat protein is not present. 25-bp repeats are not shown.

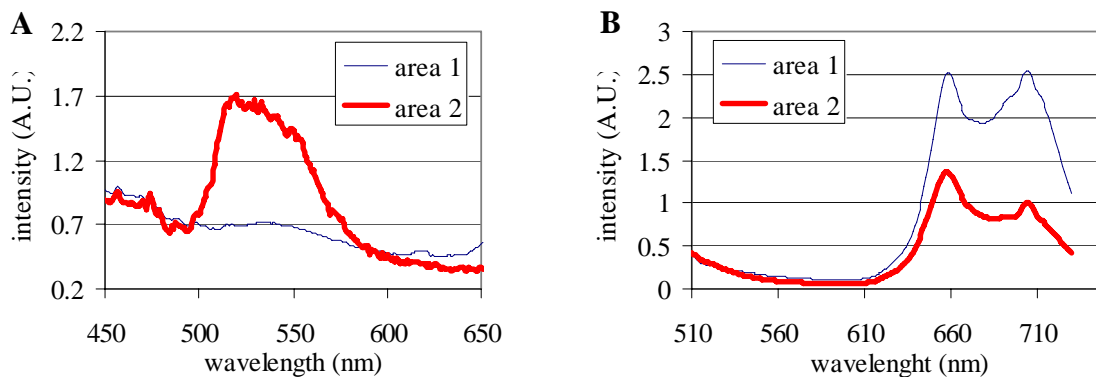
### Control for quantitative fluorescence imaging

Two days after the transfection, glowing patterns can be observed when the plants were illuminated with a UV handheld lamp. To verify that the visually detected pattern was TMV-GFP, a leaf was removed and placed in a spectro-fluorometer to acquire its emission spectrum. As shown in figure 2, the visually glowing area (area 1) significantly increased in emission intensity at about 520nm relative to the non-glowing area (area 2). 520nm is the signature wavelength of GFP.



**Figure 2**, Emission spectra of an infected leaf under A) 365nm UV and B) 480nm excitation illumination. Area 1 expressed visually detectable fluorescence. Area 2 was far from the point of infection and is used as a reference.

GFP could be excited by blue (480nm) light as well as UV. To compare the difference, an emission spectral scan was also taken using 480nm excitation wavelength. When excited with 480nm, the inelastic scattering of the excitation light spread over the wavelength of GFP emission. The signal to background ratio is reduced. It was determined from the emission scan that 365nm UV should be used for excitation and an emission filter passing light between 500 to 600nm should help discerning the GFP signal. A shorter wavelength (<500nm) contains mostly the scattered excitation light. The longer wavelength region (>600nm) has signal irrelevant of the infection. Its spectral signature matches the autofluorescence of chlorophyllchlorophyll (Halfhill et al., 2003).



**Figure 2**, Emission spectra of an infected leaf under A) 365nm UV and B) 480nm excitation illumination. Area 1 expressed visually detectable fluorescence. Area 2 was far from the point of infection and is used as a reference.

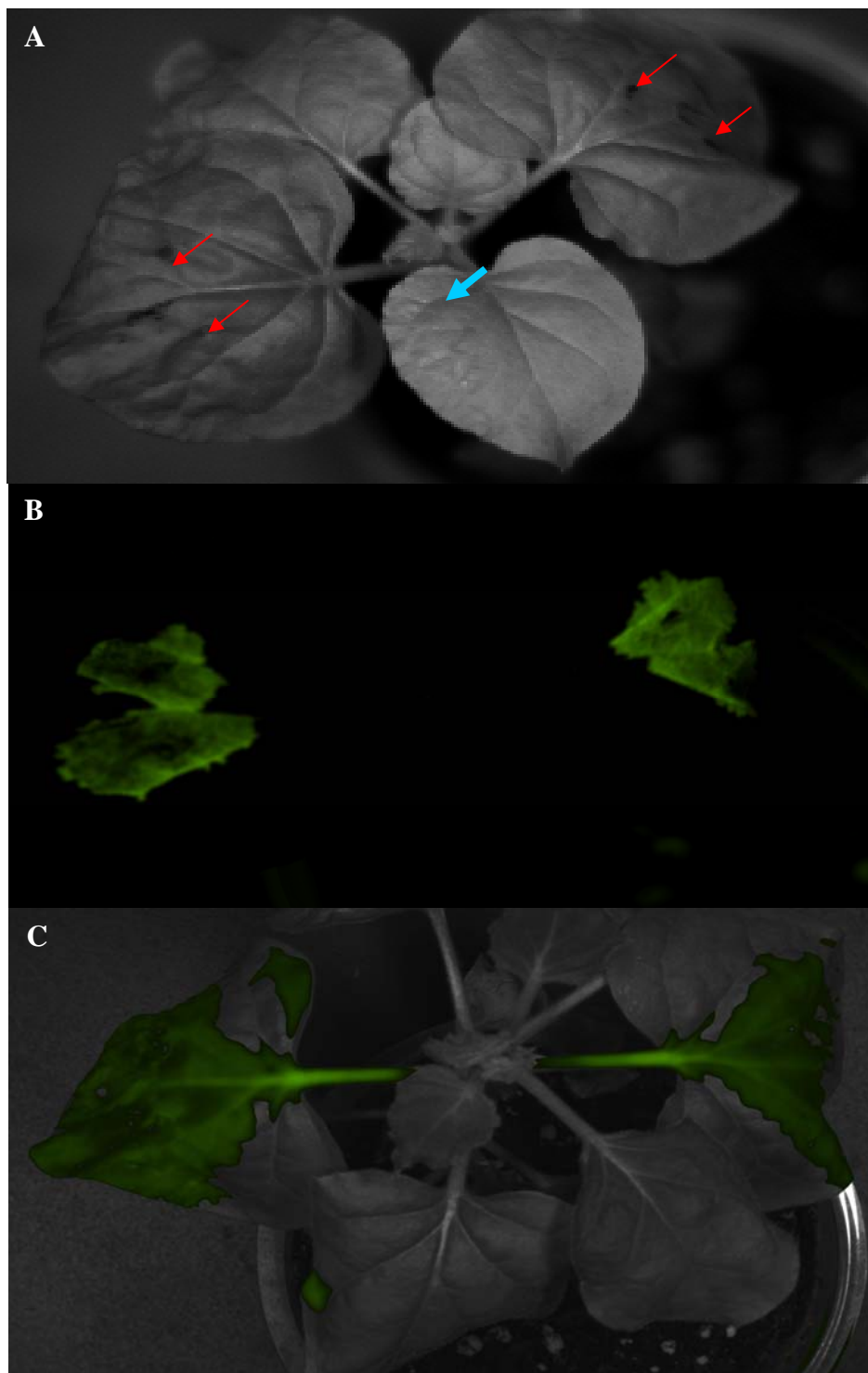
### **Instrumentation for time lapsed, non-invasive, in-vivo whole plant imaging**

To monitor the expression and propagation of the virus over time in one live *A. tumefaciens* *N benthamiana* plant, an UVP BioSpectrum Imaging System was used to perform fluorescence imaging on the infected plant. Built-in 365nm overhead UV was used for excitation. To ensure the maximal dynamic range, the system was set to automatically acquire fluorescent images using a series of 10 different exposure time settings (25msec to 12.8sec). The cooled CCD camera has no noticeable noise at the long exposure time. The plant was set on the mechanical lift inside the imaging darkroom such that the height of the leaves of interest can be controlled to keep a constant distance with the UV light source and the camera. When the intensity of the excitation light and the distance of the observation are held at constant, the fluorescence intensity is mostly varied by the concentration of virus.

### **Results**

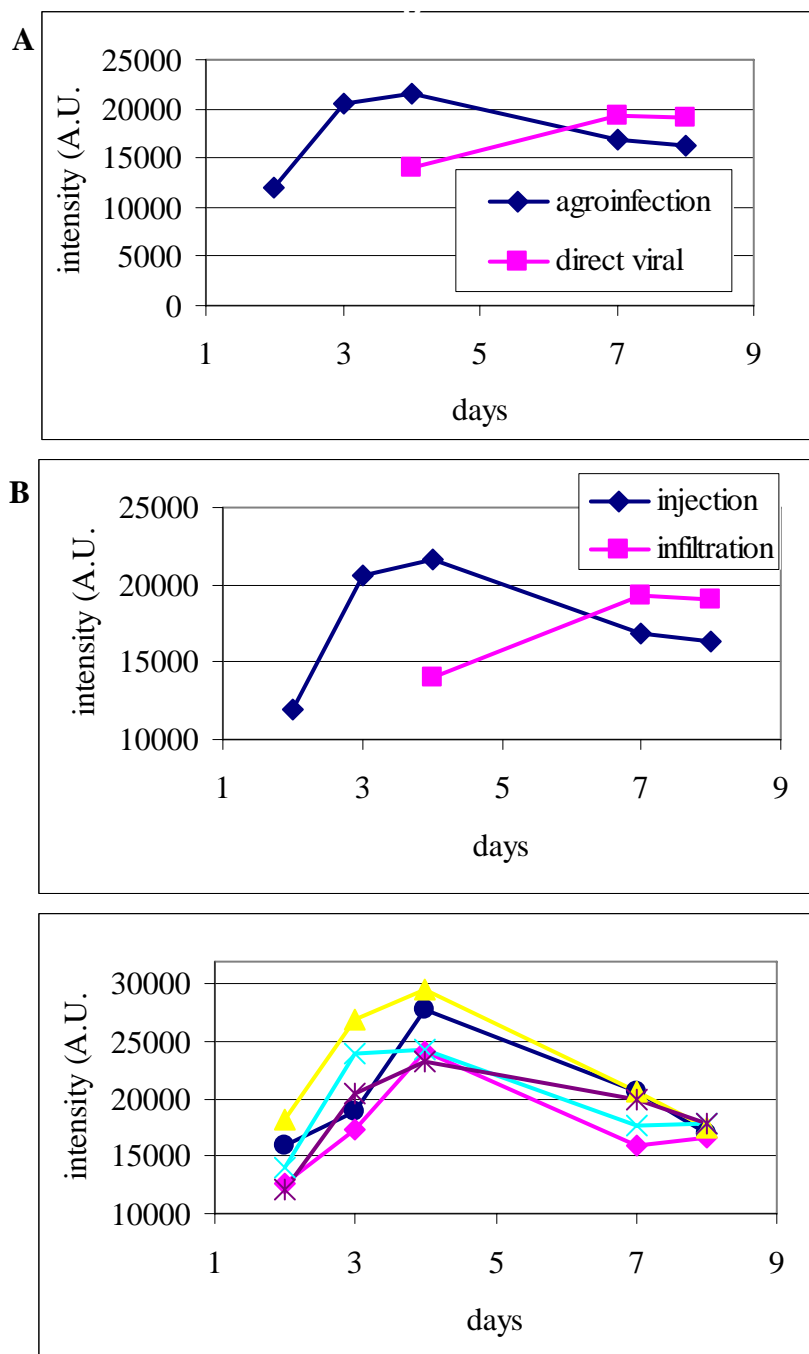
Leaves of the plants were infected with bacteria which contains the GFP-TMV RNA. The bacteria can either be injected or were infiltrated using the agro-infection method, as shown in figure 3A. The plants were grown under normal control condition and daily moved to the imaging system for measurements. As early as 48 hours after infection, fluorescence can be observed around the point of infection (figure 3B). Unintentionally, one leaf was showing signs of direct viral infections without the punch mark from agro infection. This can be created from an accidental drop of the infectious fluid on the leaf. This leaf showed fluorescence two days later. The speed of propagation and the intensity of fluorescence are both higher in the stems than in the leaves (figure 3C).

The fluorescence images allows quantitative studies of the viral expression. On different leaves of the same plant, the fluorescence around the infiltration area was observed two days earlier than the infection (figure 4A). The averaged intensity in all detected areas shows that the amount of detected GFP-TMV reaches its maximum 4-dpi. If the bacteria were initially infiltrated, the fluorescence doesn't reach maximum until seven days passed infection. Figure 4B shows the average intensity of five infected areas from two different plants, five infection points showed maximal expression at the same dpi.



**Figure 3A)**, white White light image of one plant 24 hours after infection. The thin red arrows indicate the point of injectioninfiltration, and the blue arrow points to an infiltrationarea of initial viral replicationviral infection point without the agro infection punch mark. **B)** the fluorescent image of the same plant at 2-dpi in green pseudo color. **C)** the overlay of the fluorescent image and the white light image at 10-dpi.





**Figure 4**, quantitative comparison of viral expression from **A**) different infection methods on the same plant and **B**) injected infection on five leaves of two different plants.

The result of the fluorescence macro imaging suggests that using the designed TMV plasmid would give the highest yield if the plant tissue was harvested at 4-dpi.

## Discussion

### GFP as a quantitative reporter in live plants

Lindbo (2007) had previously published on using the pJL TRBO vector to report the viral expression in live plants. The amounts of GFP destructively extracted from plants were used to compare the effectiveness of pJL TRBO and other vectors. Although the intensity of fluorescent images shown by Lindbo do seem to correlate with the amount of GFP extracted, it was impossible to compare the day-to-day increase of the viral expression on the same leaf using the destructive method.

To report the viral expression quantitatively with the non-invasive fluorescent method, several variables must be well controlled. Because the produced fluorescence is the function of excitation power and concentration of GFP, the intensity of the excitation illumination per unit area on the sample should be held at constant. In our setup, the UV light source was fixed at the top of the imaging cabinet, and the plant was placed on a computer control lift which can be lowered to maintain a constant distance between the light source and the plant despite its growth over time. This allows the possibility of maintaining the constant excitation power level.

In figure 4A, the infected areas reached their maximums at different dpi. As it is expected that the process should be accelerated when the virus was introduced with agroinfection, the temporal difference of the two curves serves as a control which promises that the increase in fluorescence is from increase of viral expression and not the fluctuation of the imaging setup. Furthermore, as shown in figure 4B, several infected areas on different plants all demonstrated the same temporal behavior: the averaged intensity in all detected areas shows that the amount of detected GFP-TMV reaches its maximum 4-dpi. This is consistent with Lindbo's finding.

## Conclusion

Fluorescence intensity acquired from leaves infected with GFP-TMV can be used to monitor protein production repeatedly and non-invasively. The result of the fluorescence macro imaging suggests that using the designed TMV plasmid and agroinfection method would give the highest yield per infected area, when plant tissue is harvested at 4-dpi.

## Future work

The pJL TRBO vector is expected to have greatly reduced long range mobility (Donson et al., 1991). Quantification of GFP expression in infected plants may be used to compare the mobility of viruses with altered gene sequences.

## Reference

Kohl, T., Hitzeroth, I. I., Stewart, D., Varsani, A., Govan, V. A., Christensen, N. D., Williamson, A.-L., and Rybicki, E. P. (2006) Plant-Produced Cottontail Rabbit Papillomavirus L1 Protein Protects against Tumor Challenge: a Proof-of-Concept Study. *Clinical and Vaccine Immunology*, 13:845-853.

Grill, L. K., Palmer, K. E. & Pogue, G. P. (2005). Use of plant viruses for production of plant-derived vaccines. *Critical Reviews in Plant Sciences*, 24(4), 309-323.

Halfhill, M. D., Millwood, R. J., Rufty, T. W., Weissinger, A. K., and Stewart, C. N., Jr. (2003). Spatial and temporal patterns of green fluorescent protein (GFP) fluorescence during leaf canopy development in transgenic oilseed rape, *Brassica napus* L. *Plant Cell Reports*, 22:338-343.

Lindbo, J. A. (2007) TRBO: A high-efficiency tobacco mosaic virus RNA-based overexpression vector. *Plant Physiology*, 145, 1232-1240.

Donson J, Kearney CM, Hilf ME, Dawson WO (1991) Systemic expression of a bacterial gene by a tobacco mosaic virus-based vector. *Proc Natl Acad Sci USA* 88: 7204–7208

### **Biographical Information**

Claudia Lee: Software program manager at UVP, LLC.

Andrew Zepfel: Student at Claremont McKenna College.

Nina Timberlake: Student at Scripps College.

Larry Grill: Director of Vaccine Development Institute at Pitzer College

Sean Gallagher: Chief technology officer at UVP, LLC.

## **CIBRED: Engineering Education on Cyberinfrastructure with a Multidisciplinary Approach for Non-Engineering Students**

Arun K. Datta,<sup>1,2,\*</sup> Jacqueline Caesar,<sup>1,3</sup> Daphne Rainey,<sup>4</sup> Stephen Cammer,<sup>4</sup> Julie Schuman,<sup>4</sup>  
Oswald Crasta

<sup>1</sup> National University of Community Research Institute (NUCRI), <sup>2</sup> School of Engineering and Technology, <sup>3</sup> College of Letters and Science (COLS), National University, San Diego, CA;  
<sup>4</sup> Virginia Bioinformatics Institute, Virginia Tech University, Blacksburg, VA.

\*For Correspondence

### ABSTRACT

Although the role of cyberinfrastructure in engineering education and research is advancing, the use of the concept and infrastructure are quite limited in the courses for the allied health professionals. CIBRED\* (CI-TEAM Implementation for Biological Researchers, Educators, and Developers), an NSF funded project, provides a unique opportunity for these authors to introduce the concept of cyberinfrastructure to non-engineering educators and students by designing, developing, and deploying course materials with a interdisciplinary approach. At present, two courses are being developed for deployment and assessment during Fall of 2009. These interdisciplinary courses are being developed in a modular format integrating scientific and technology information from a variety of disciplines. These modules can be incorporated into existing or newly developed courses. One module is for allied health professionals to learn about cyberinfrastructure for healthcare management. The other module focuses on human migration, which introduces engineering education to the undergraduate students from humanities and social sciences. Project-based learning concepts have been implemented in developing these courses to teach various relevant disciplines. The focus is to teach students from diverse disciplines some essential concepts on computer technology in the context of applying cyberinfrastructure. These courses developed for K13 & K14 levels will be offered in an innovative classroom setting for hands-on experimental learning with a focus on solving scientific problems as a team. These courses will also be deployed for online learning in a virtual classroom. The effectiveness of such an approach, introducing concepts from engineering education to the non-engineering students, will be assessed through formative and summative methods for further development and dissemination.

---

\*CIBRED is funded by NSF award OCI-0753375 to O. Crasta

### INTRODUCTION

Advances in various technologies in biology, medicine and computation have enabled researchers to generate more experimental data for understanding medical science at the molecular level. This

trend is now common in most of the scientific fields that can be exploited for data utilization, data analysis and more useful data mining and visualization of data. Moreover, the advances in computational technology are changing the way research is conducted in all aspects of science and have led to the generation of seemingly limitless possibilities of national and international collaboration and sharing of data for research, education and training. The Office of Cyberinfrastructure (OCI) was created at the National Science Foundation in June 2005<sup>1</sup> following the recommendation of a Blue Ribbon Committee chaired by Daniel Atkins of the University of Michigan to formulate the scientific policies leading to more useful collaboration using computer technology and coordinating these activities building the infrastructure<sup>2,3</sup> The vision of the OCI is making it possible to bridge the gap between the research data infrastructure and the scientific community through federated database systems, collaboratories, and a powerful portal with high performance computing capability for tracking, analyzing, visualizing and interpreting the experimental data and results<sup>4</sup>. Through competitive, merit-reviewed awards for leading-edge, IT-based infrastructure, which is increasingly essential to science and engineering leadership in the 21st century, OCI is developing an infrastructure, termed Cyberinfrastructure (CI) to facilitate rapid progress in education and research.

### **Cyberinfrastructure and teragrid**

“Cyberinfrastructure” describes integrated information and communication technologies for distributed information processing and coordinated knowledge discovery, which promises to revolutionize the way that science and engineering are done in the 21st century and beyond<sup>3</sup>. It is the coordinated aggregate of software, hardware and other technologies, as well as human expertise, required to support current and future discoveries in science and engineering. Thus, CI includes supercomputers, data management systems, high capacity networks, digitally-enabled observatories and scientific instruments, and an interoperable suite of software and middleware services and tools for computation, visualization, and collaboration<sup>1</sup>. The challenge is to integrate relevant and often disparate resources to provide a useful, usable, and enabling framework for research and discovery characterized by broad access and “end-to-end” coordination. NSF has sponsored projects to develop principles for the “design and evaluation of IT-enabled scientific "collaboratories," or "centers without walls" in which researchers can perform their research without regard to physical location, interacting with colleagues, accessing instrumentation, sharing data and computational resources, and accessing information and data in digital libraries and

repositories” (details at [www.nsf.gov](http://www.nsf.gov)). One such project, TeraGrid, is a national-scale high performance computing facility to provide large scale resources and services in support of advancing scientific research and education<sup>5,6</sup>. Presently, TeraGrid (TG) includes 11 Resource Providers (RPs) and is a leader and major component of the emerging national and international e-Science (details at [www.teragrid.org](http://www.teragrid.org)). TeraGrid is an open scientific discovery infrastructure combining leadership class resources at partner sites to create an integrated, persistent computational resource. Using high-performance network connections, the TeraGrid integrates high-performance computers, data resources and tools, and high-end experimental facilities around the country. Currently, TeraGrid resources include more than a petaflop of computing capability and more than 30 petabytes of online and archival data storage, with rapid access and retrieval over high-performance networks. Researchers can also access more than 100 discipline-specific databases in TeraGrid. With this combination of resources, TeraGrid is the world's largest, most comprehensive distributed cyberinfrastructure for open scientific research. Thus, CI supported by Teragrid is becoming the foundation of 21<sup>st</sup> Century’s discovery through innovative scientific research.

Over the years, the role of CI has evolved. Initially, CI was defined by its role – a research environment to support advanced data acquisition, data storage, data management, data integration, data mining, data visualization and other computing and information processing services over the Internet. Soon the definition incorporated the advances enabled by CI and CI became the technological solution to the problem of efficiently connecting data, computers, and people with the goal of enabling derivation of novel scientific theories and knowledge. In its current stage, CI is taking its place in the advancement of education as a platform for delivery of learning content and continues to advance into a platform to expedite the transition from research data to pedagogical practice<sup>7</sup>. The latest role of CI advances in the face of the realization that a new workforce needs to be trained in the CI environments in which it will function.

Earlier, an awareness program on CI was launched under NSF funded ‘inFormation Year 06-07’ by the HASTAC organization ([www.hastac.org](http://www.hastac.org)). Among the events organized by nine participating institutions, ‘InCommunity’ was organized by the NU Community Research Institute (NUCRI) of the National University to promote the concept of CI to the community (archives can be viewed at <http://nucri.nu.edu/incommunity>). Nevertheless, integration of the engineering

concept of CI is very limited, especially to the non-engineering students due to the lack of appropriate course curriculum for schools and colleges.

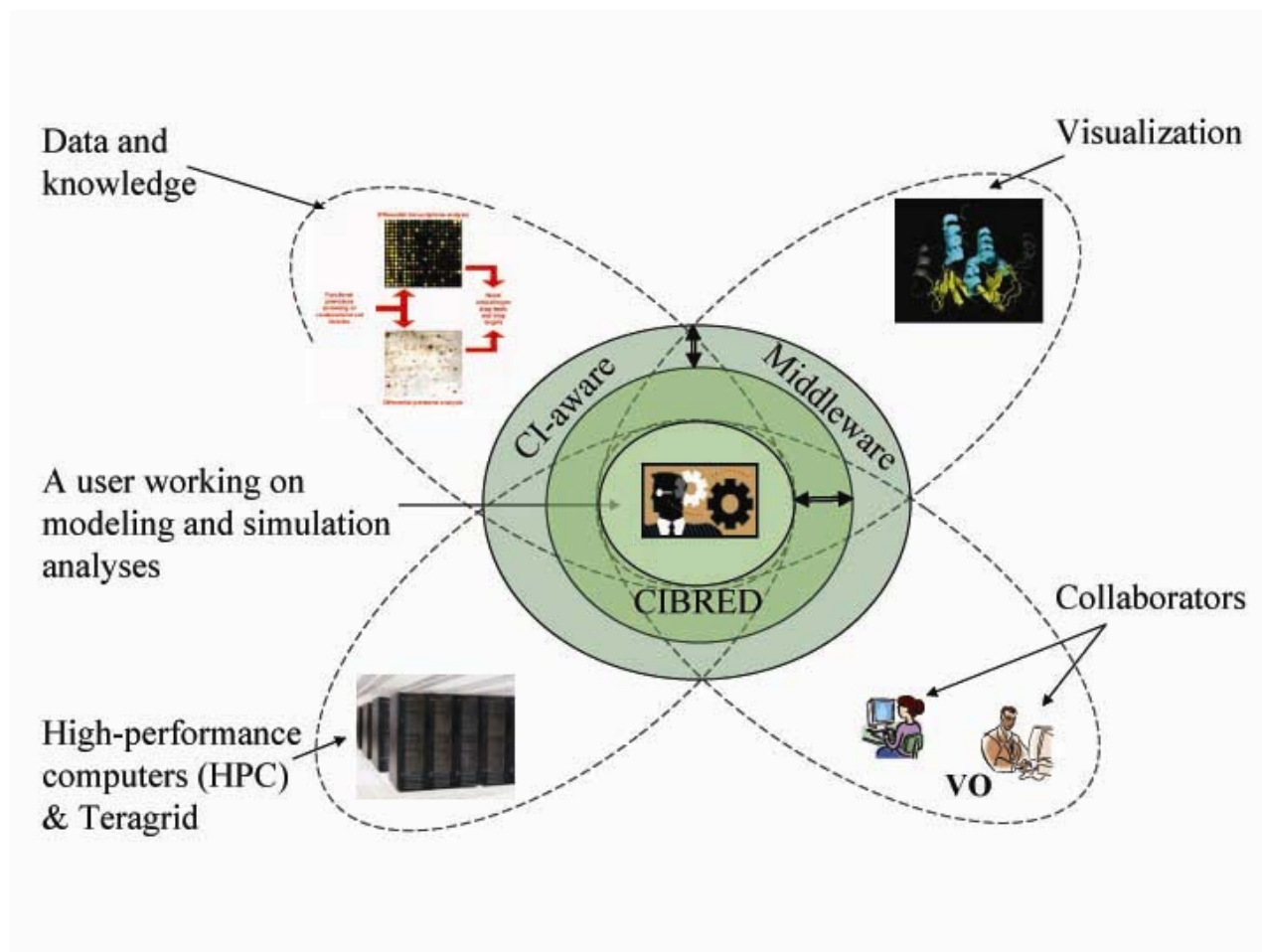
### **Skilled workforce needed to sustain CI/TeraGrid Program**

Central to this CI environment is the most important element, the skilled workforce that is required to maintain and sustain this program (Figure 1). Two components toward the development of the new workforce are needed: educators with an understanding of the demands of CI and materials for training the students. In answer to some of these needs, OCI has now established a rich source of educational and research materials through TeraGrid to meet the 21st Century's demand for scientific talent (Materials are freely available through CI/TeraGrid – [www.teragrid.org](http://www.teragrid.org)). Additionally, OCI put forth the CI-TEAM (Cyberinfrastructure, Training, Education, Advancement, and Mentoring for Our 21st Century Workforce) program to aid education initiatives directed toward this new workforce. Training of a 21<sup>st</sup> Century workforce demands students have a firm grounding in interdisciplinarity, especially in the sciences.

Today's young generation born in the technological landscape of the digital age is already familiar with participatory media<sup>8</sup> and the practice of integrating knowledge with the aid of digital tools, such as, iPhone or Google phone, and even interacting with unseen peers in the digital metaverse space, such as, in Second Life (<http://secondlife.com/>). The goal now is to harness and develop these skills. However, the problem is to find instructors who can meet the challenge of training these students and serve as a bridge between these techno-savvy students and the scientific discoveries happening in the CI supported techno-sphere. Many educators today are not familiar with the requirements of the 21<sup>st</sup> Century digital age where information literacy<sup>9,10</sup> and multimedia savvy are required skills.

### **The role of CI in education and training and CIBRED**

The National Research Council and the US Department of Education conducted a study<sup>11</sup> to evaluate teaching and learning and the use of technology. This study recognized that the proper use of computer technology helps the learning process. Computational technologies have proven to have profound impacts on the practice of science and engineering<sup>3</sup>. TeraGrid has developed many resources of research and educational materials exploiting the computational technologies (TeraGrid07 & TeraGrid08). CI's and its role in adhering systems, tools, and services emerging



**Figure 1.** Relationships between the knowledge worker at the center of the CI with high-performance computers and Teragrid, middleware, VO (virtual organizations), data management and knowledge discovery, and visualization services. The objective of CIBRED is to educate and bring awareness of CI (Courtesy of S. Wang<sup>12</sup>; courtesy of Stan Watowich<sup>13</sup>).

from computational technologies, enables individuals, groups, and organizations to advance research and education in ways that revolutionizes the practice of participation. Once again, a new workforce empowered with the knowledge and skills to design, deploy, adapt and apply CI, are needed to sustain this revolution across all areas of science and engineering. The OCI CI-TEAM program supports educational training projects that position the national science and engineering community to engage in integrated research and education activities promoting, leveraging and utilizing cyberinfrastructure systems, tools and services (more info at, <http://www.nsf.gov/crssprgm/ci-team/>).

One such program, CIBRED (CI-TEAM Implementation for Biological Researchers, Educators, and Developers), brings together faculty, researchers, educators, and academic



administrators from multiple institutions to design, develop and deploy course materials in a collaborative way with the objective of preparing future scientists, engineers, and educators to adopt and deploy, cyber-based tools and environments for research and learning, both formal and informal (for more detail, see: [cibred.vbi.vt.edu](http://cibred.vbi.vt.edu)). The activities involve a diverse group of people and organizations, with particular emphasis on the inclusion of traditionally underrepresented individuals, institutions, and communities as both creators and users of cyberinfrastructure. Like all CI-TEAM funded projects, CIBRED seeks to broaden and diversify the population of individuals and institutions leveraging existing or current development efforts in cyberinfrastructure technologies, open software standards and open educational resources. The vision of this program is to realize the potential of cyberinfrastructure and high performance computing to empower a larger and more diverse set of individuals and institutions to participate in science and engineering education, research and innovation. The mission is to develop and evaluate an extensible, scalable, and comprehensive learning program for the students at academic institutions to effectively utilize CI and TeraGrid resources and services, to advance scientific discovery in all fields.

Six fundamental tenets underlie the CIBRED project:

1. New scientific discovery will increasingly require transdisciplinary research within a cyberinfrastructure (CI) environment.
2. Scientists require increased knowledge and proficiency in team science to conduct transdisciplinary research within a CI environment.
3. There is a decrease in the number of students entering the STEM disciplines.
4. Curricula for existing students require new courses that are built on the principles of team science and methodology for conducting transdisciplinary research within a CI environment.
5. Learning environments must increasingly engage students in STEM disciplines, build awareness of team science and transdisciplinary research within a CI environment, and inspire students to further investigate or pursue a career in these areas.
6. To prepare future scientists, existing researchers and developers must be linked to educators and learners to create data-rich learning environments.

CIBRED, will help bridge this gap by training the trainers through workshops. Although TeraGrid and SC Community (<http://sc08.supercomputing.org/>) periodically conduct courses through workshops to train people for CI/TeraGrid, CIBRED workshops will specifically serve the school teachers and college instructors to enable teaching CI embedded courses in the classroom.

### **CIBRED for interdisciplinary courses**

This project was not proposed to design courses for a specific scientific discipline, but rather to utilize the information from multiple disciplines while developing some courses for CIBRED. Participating institutes are: Virginia Tech University (VT), National University, Howard University, Hampton University, Denbigh High School, Pheobus High School, Blacksburg High School, Auburn High School, and Galileo Magnet High School. The project established the objectives and goals for team collaborations via a kick-off meeting on April 10, 2008 (The agenda and the copy of all presentations of this meeting can be found at: [http://staff.vbi.vt.edu/bsharp/CIBRED\\_Workshop/Minutes.htm](http://staff.vbi.vt.edu/bsharp/CIBRED_Workshop/Minutes.htm)). A variety of CIBRED-course materials for both high school (K8 -K10) and college levels (K13 – K14) are under development by the participating institutions. These course materials are being developed in a modular way, the concept of CI as the common module, for disseminating institutions to choose from according to their standards of learning. The courses are developed by integrating scientific and technology information from a variety of interdisciplinary fields ranging from basic concept of CI, Molecular Biology, Bioinformatics, Genomics and Proteomics to Health Informatics into modules. These modules can be incorporated into existing or newly developed courses. To accommodate specific needs of various institutions and to facilitate adaptation by additional institutions in the future, we have standardized the framework in the following areas<sup>14</sup>:

- a. Introduction to CI
- b. Inclusion of current research (context, data, and tools)
- c. Role-based involvement of the students for transdisciplinary learning; and
- d. Forward-looking conclusion of the project with review of the CI systems.

Project based learning concepts<sup>15-18</sup> have been implemented in developing these courses to teach various relevant disciplines. The focus is to teach students from diverse disciplines essential concepts on computer technology in the context of applying CI. The type and number of role-based modules to be incorporated into a CI course will be solely at the discretion of the deploying

institution. Each course will finish with a CI reflection component that reiterates the basic CI components learned, relates them to the role-based modules, and addresses the potential applications of both the specific scientific domains utilized and CI.

### **CI for allied health professionals**

Concerns for the seemingly exponential rate of increase in US healthcare costs have had an impact on the national economy. This concern was reflected in President Obama's first State of the Union Address on February 24, 2009. A component of these rising costs has been identified as the lack of coordination of patient medical records due to the continued and widespread use of paper records. The use of paper records inhibits the ability to coordinate care, measure quality, and reduce medical errors. Processing paper claims also costs twice as much as processing electronic claims. The Obama administration has adeptly targeted a strategy to increase the use of healthcare informatics as a means to update the healthcare system and simultaneously reduce costs associated with uncoordinated patient information. A thorough analysis of the present state of healthcare has revealed that the lack of standards for sharing health related information contributes to increased health care costs through a redundancy of services<sup>19</sup>. Developing the state of health informatics has the potential to eliminate many of these concerns and increase the efficiency of the system. The present US administration's plan is to invest approximately \$50 billion over the next five years to move towards the adoption of standards-based electronic health information systems, including electronic health records in the nation's health system. In February 2009, President Obama provided \$19.2 billion for health IT in the American Recovery and Reinvestment Act. This legislature is expected to create a demand for skilled healthcare professionals with knowledge of CI. With this in mind, a CIBRED course, 'Cyberinfrastructure in Healthcare Management' has been created for the students at undergraduate level (K13-14).

Medical informatics is a transdisciplinary science that requires domain knowledge of various disciplines, such as, medical science (anatomy, physiology, etc.), molecular biology and bioinformatics, computer technology, among other fields. In the field of modern molecular medicine, advanced computational technologies will certainly play an important role in managing and analyzing massive quantities of medical data once knowledgeable workers are available to serve this growing field. In the treatment of cancer, for example, it is already accepted that it is more beneficial if a patient is treated on the basis of his/her personal health profile by using

information obtained from various data including data from microarray analysis, toxicogenomic analysis, pharmacogenomic analysis<sup>20,21</sup>. Such analysis supported by CI will enable a medical specialist to treat a cancer patient in future by prescribing right medicine at the right dose(s) based on the individual's profile. Over time, it has been realized that individuals respond differently to drugs and sometimes the effects are unpredictable. Safer treatment will utilize the knowledge synthesized from the intersection of genomics and medicine supported by CI, which has the potential to yield a new set of molecular diagnostic tools that can be used to individualize and optimize drug therapy<sup>22</sup>.

As discussed during BIO2008, it is becoming clear that a new understanding of the dynamic interplay between genes and environment, made possible by technologies arising from the Human Genome Project, helps support the individualization of medicine<sup>23,24</sup>. Currently, available software tools and focus on data analysis do not provide a platform for the management of patient information<sup>25</sup>. A shift in technology fueled by computational thinking<sup>26</sup> is needed to speed the coupling cyberinfrastructure and medical informatics rapidly and economically<sup>25,27</sup>. Computational modeling and simulation based on cyberinfrastructure-enhanced medical informatics allows researchers to tackle large and complex medical problems<sup>28</sup>.

Although the author (AKD) has gained knowledge in both the molecular biology and computer science by educational training and working several years in medical institutes, it is virtually impossible for any one educator/domain expert to develop a course focusing on transdisciplinary concepts and problem solving needed to train the health-informaticians and others needed to serve the 21<sup>st</sup> Century workforce. A collaborative framework has been designed involving domain experts from the Virginia Bioinformatics Institute at Virginia Tech and the National University in an attempt to develop such a course. Modules will be used so that subjects can be flexible enough for adapting the course. The current modules focus on helping students to develop and understanding of the importance of cyberinfrastructure framework to address critical issues at the societal level, thus introducing the transdisciplinary nature of the project. The course has four main modules: 1) Introduction to CI, 2) Molecular Biology and Bioinformatics, 3) Health Informatics, 4) Vaccine Development and Drug Discovery. The second module is being developed with the help of domain experts available from the Virginia Bioinformatics Institute at Virginia Tech. One author (AKD) is developing the third module 'health informatics'. The Health

Informatics module stems from a course developed and taught for undergraduate allied health professional students at the School of Health and Human Services at the National University. The feedback obtained from the students has become useful in developing this current module. The other two modules are being developed by these authors with the feedback from TeraGrid Resource Providers, feedback from the Campus Champion Program<sup>6,29,30</sup>, University of California-San Diego, and The Scripps Research Institute.

One case study used in the project is dengue management. Nevertheless, for the project, an instructor can consider any other disease management using this case study as a model. Dengue, transmitted to humans by the domestic, daytime-biting mosquito, *Aedes aegypti* (Figure 2), is caused by four closely related virus serotypes of the genus *Flavivirus*, a member of the family *Flaviviridae*. Each serotype is sufficiently different that there is no cross-protection and epidemics caused by multiple serotypes (hyperendemicity) can occur. According to WHO, 50 million cases



**Figure 2.** This infected female mosquito, *Aedes aegypti* (and rarely *Aedes albopictus*) transmits dengue virus to humans through the bites. Mosquitoes generally acquire the virus while feeding on the blood of an infected person. After an incubation period of eight to 10 days, an infected mosquito is capable, of transmitting the virus during probing and feeding for the rest of its life<sup>31</sup>. Public awareness to control this daytime-biting domestic mosquito needs to improve through education and community outreach.

are reported annually across the globe (Figure 3). Often the victims suffer from more serious symptom, Dengue Hemorrhagic Fever (DHF/DSS), which may turn fatal. In 2002 alone, 91 deaths occurred in Brazil. This disease previously unknown in US is becoming a concern of the Center for Disease Control (CDC). National Institute of Allergy and Infectious Diseases (NIAID) experts now see dengue as potential threat to U.S. health<sup>32</sup>. Unfortunately, there is no drug or vaccine, at present, to cure dengue. Public health education to control the mosquito or the disease is not good enough even in the countries where it is prevalent. Outbreak of this disease is also common. Moreover, global warming apparently is changing the pattern of infection: more people residing at higher altitude in countries like Costa Rica are becoming infected, causing a grave concern. There are various elements to learn by studying this disease, and thus, may be used as a case study for CI – supported disease management.



**Figure 3.** Global distribution of dengue infection. The vector mosquitoes are prevalent in tropical and subtropical areas. However, these are now causing concern not only in Central and South Americas but also in North Americas. Apparently climate change has a profound effect on these vectors. People residing in higher altitude in Costa Rica, as for example, are becoming infected.

### **Method of teaching/learning - Project-centric hands-on experimental learning**

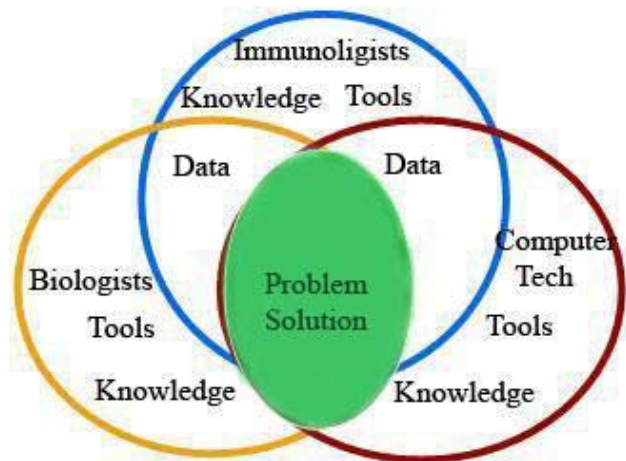
Learning is a complex phenomenon that depends on various factors including the student's state of mind<sup>11</sup>. The same topic delivered by the instructor in the classroom is 'learnt' differently by different students. There are various techniques to improve the teaching techniques for facilitating learning<sup>33</sup>. Among the teaching techniques we tested, we realized that agile techniques supports learning techniques better<sup>34</sup>. In general, many strategies can be employed, including problem-based learning<sup>15-18</sup>, technology-based learning<sup>35</sup>, game-based learning<sup>36,37</sup>, work-based learning<sup>38,39</sup>, inquiry-based learning<sup>40,41</sup>, project-based learning<sup>42,43</sup>, team-based learning<sup>44</sup>, web-based learning<sup>45,46</sup> and participatory learning<sup>8</sup>. Our approach for teaching this course centered on project-centric learning<sup>14</sup> with support of agile teaching technique<sup>34</sup>. The course has been designed with background information (cyberinfrastructure) introduced at the beginning and summarized at the end. However, how to balance the load (in terms of both time and knowledge) among students from multiple disciplines remains a challenge.

A disease management includes a variety of disciplines including Clinical study, Public health education and training, Epidemiology, Environmental issues, local and national resources supported by Geospatial Information Systems (GIS) in case of an outbreak/epidemic, Electronic

Health Record and other Health Informatics –tools and Services, Disease outbreak predictive tools, Decision Support Systems, Drug Discovery Research, Vaccine development - to name a few. Moreover, a student needs to know various public policies including HIPAA compliance (see: <http://www.hhs.gov/ocr/privacy/index.html>) and FERPA (see: <http://www.ed.gov/policy/gen/guid/fpco/ferpa/index.html>) for school-aged children. Patient's data sharing even among the healthcare service providers are restricted by these compliances. The law also dictates how the permission should be obtained from parents while sharing the health related data on minors.

In a typical classroom setting, an instructor will initially provide all the relevant information on this disease management supported by this course through lecture and demonstration. In this phase, the CIBRED course instructors will provide background information necessary for the students to understand the scenario for the project and to develop strategies for investigations including identification of the virus, accessing the TeraGrid and National network of bioinformatics resources, and suggesting control of preventive measures in case of an outbreak and the role of Geospatial Information Systems (GIS) in coordinating the resources. In the second phase, following the agile problem driven teaching techniques<sup>34</sup>, an instructor will survey the students' aptitude & interest and will facilitate forming a group/team working on a given project, such as, dengue case management. The students will then work through the scenarios assuming different roles in the team. Each team may utilize different tools and address the problem from a different perspective. Some students can assume a role as clinicians, as for example, to 'diagnose' the disease by conducting a series of pathological tests including blood tests and checking the physical symptoms. In doing so, the students need to learn what the symptoms are for dengue and what sort of laboratory tests are required to diagnose such a case. This dengue management project will specifically require students to use various computational and web based tools to discover the identity of the virus, given some preliminary biological data under the supervision of the instructor and in consultation with the researchers and sequences to test a hypothesis regarding the origin of the sample sequence (Figure 4). Students will practice what they would learn by becoming familiar with large, CIBRED team. They should also need to learn about the DNA sequencing that generates a code for a portion of a pathogenic genome derived from a biological or environmental sample. The project will require learning about how gene sequences are stored and how to access

these comprehensive repositories such as the NCBI database Gen-Bank, and focused bioinformatics resources, such as, Patho-Systems Resource Integration Center (PATRIC),



**Figure 4.** The key to solve a scientific problem is to gather vital information from a variety of disciplines, synthesize those to acquire knowledge. These information are gathered through experiments, literature search, enquiry and communication.

Pathogen Information (PathInfo), and Molecular Interactions Network (MINet) documents that are maintained at Virginia Bioinformatics Institute (VBI), TeraGrid, Biological Workbench (<http://workbench.sdsc.edu/>) or elsewhere on the Internet. Techniques for comparing and manipulating sequences will be addressed to insure students could use similarity to a known genetic sequence to predict possible function for a sequence of interest. In the process, putative genes needed to have their sequences translated to protein sequences for functional features to be identified. Predictions of structural features of the protein, such as secondary structure, signal sequence and transmembrane segments, will provide them the first clues as to what types of proteins are present. They will learn the basic information on proteins, how a protein is synthesized in a living cell and folded into a 3D-structure, what factors primarily are responsible for folding into that structure, how a protein can be selected as a drug target. Protease is regarded as a potential drug target for dengue<sup>48,49</sup>, and the references therein). Some students can use molecular modeling techniques for this protein<sup>50</sup>, during the investigation. Target selection can, however, be made after several proteins are investigated using multiple data resources, including expression



data where available. Experimental laboratory analysis could provide students with new information about the target that may be analyzed to generate possible leads in the search for drug candidates. In the process, students will also learn about small molecule drug discovery supported by World Community Grid (<http://www.worldcommunitygrid.org/>) of IBM and how that is being used by a scientist, Stan Watowitch, at The University of Texas Medical Branch (Galveston, TX) for small molecule potential drug candidates against dengue virus<sup>51</sup> (also, see the story at <http://www.tacc.utexas.edu/research/users/features/worldgrid.php>). Searching his publications in PubMed followed by reviewing the information, and may even interacting with his team at UTMB, the students will learn how computational screening is done for identifying small molecules as potential drug candidates and later conducting cell biology experiments to verify their computational screening results. They will also learn how a small molecule candidate drug can be ‘discovered’ through structure-based drug design technique when a 3D- structure of the protein molecule is known following the experiments using X-ray crystallography or NMR technique. Some students can assume a role as researchers for vaccine development. They will learn what is vaccine, what is immunity, what is antibody and how do they take part in conferring immunity against a disease, such as, dengue.

They will also learn how the environment plays an important role in host-pathogen interaction (Figure 5). In the process, they will need to know the genus (Flavivirus) and family (Flaviviridae) of a dengue virus. They will also learn how a single family can be responsible for causing multiple



Figure 5. Environmental factors play important roles in the host-pathogen interaction<sup>47</sup>.

major diseases including hepatitis C, dengue, Yellow fever, and West Nile fever. They will learn that these viruses are positive strand RNA viruses and their mode of pathogenicity is similar (see: <http://www.bioinformatics.org/dengueDTDB/Pages/main.htm>). It will be necessary to characterize

the family and use the sequences to generate a multiple sequence alignment to profile the family for subsequent investigation. They will also learn how a ‘protein motif’ can be selected using computational technique and bioinformatics tools before selecting the right monoclonal antibody(ies) for clinical trial. Such a study is being done in the laboratory of Eva Harris at UC-Berkeley<sup>52,53</sup>. Her collaboration with researchers in Managua (Nicaragua) has established informatics system to identify and monitor dengue infected cases<sup>54</sup>. Most of these information and experimental results are available in PubMed. In addition, this approach will provide the students unique opportunity for hands-on experimental learning with a focus on solving scientific problems as a team. At the end, it is expected that the members of each sub-team will generate a report on their analyses and present those to the other team members. These reports should contain enough information and need to be presented in a clear fashion for other members to understand the information and for the entire group to agree upon a conclusion. Such exercise will also teach them working in a team through social networking & associated tools, because it will be necessary for these students to cooperate with each other to achieve the best results. Finally, the students will assemble the information, synthesized interpretations and conclusions, and may communicate the results to the live and online community. Earlier, during the CIBRED demonstration phase, one of the participating students described her involvement to the local media, and the interview was posted for the government bio-defense agencies such as DoD, NIAID, and the scientific experts in this process.

### **CI for Humanities and Social Scientists**

A module for teaching CI impact on studying ‘Human Migration’ will be designed and deployed at the college level (K13-14). Advances in technology have had an impact not only on biological and medical sciences, but also on social sciences. Anthropologists have begun to look at the relationships between human migration and cultural diversity with a different lens. Influenced by discoveries in genetics as a result of the Human Genome Project and other scientific milestones, new data has opened the door to meaningful research and provided insights into the connections between human evolution, migration, cultural diversity and diversity<sup>55</sup> (also see, <https://genographic.nationalgeographic.com/genographic/index.html> for more information). Old concepts have been revisited in light of new information such as the role of natural selection and mutations in genetic variations and the more recent emphasis on the concept of genetic drift. Projects are underway to create an International databank for DNA samples in an effort to obtain

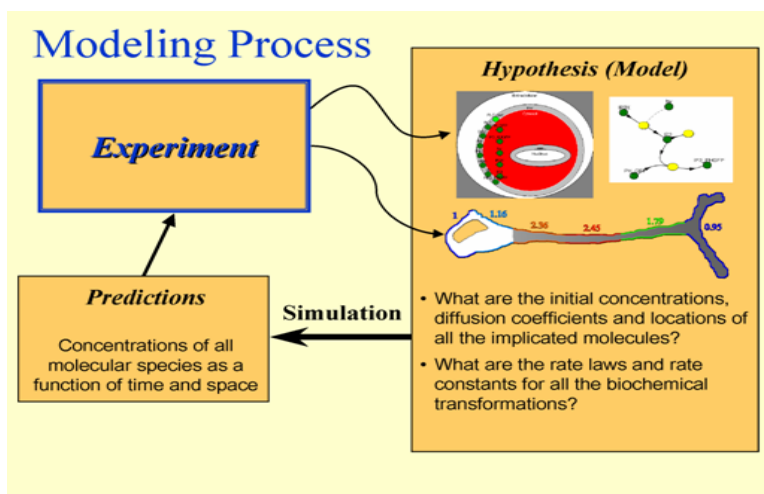
larger and more comprehensive data sources. Needless to say, an interdisciplinary and transdisciplinary academic approach that includes cyberinfrastructure, science and the social science is a relevant and timely prospect for helping students become scientifically literate.

Students will be introduced to the extensive information on the evolution of mankind. Research by key theorists and practitioners, especially the most recent works of Luigi Luca, Sforza-Cavalli and Stephen Wells<sup>56-58</sup> will be explored with the idea of tracing ancestry and cultural groups and tracking scientific methodologies to the present. They will also have an opportunity to review the work of Allan Wilson and Rebecca Cann's research on mitochondrial diversity and mtDNA sequencing<sup>59</sup>, which supported the notion of a "single ancestry" prompting the sentiment "Eve is the connecting link for humankind." Information from the National Institutes of Health's National Human Genome Research Institute offers examples of human migration and genetics (see: <http://www.genome.gov/25019968>). Other scientific search data sources will be included that will focus on understanding cells, genes, DNA, chromosomes (mtDNA and Y - chromosome) and the impact of the environment on diseases. Assignments will be directed toward investigating and gathering data from the major sources identified earlier especially the NCBI Gnome database (the Genome sequence, gMap and Map Viewer and Salmonella SNP), the analytical tools in BLAST, the modeling of the Virtual Cell by CMC-Nature Gateway (Figure 6).

Based on the scientific inquiry model, groups of students will actively engage in experiential projects that are designed to trace patterns of migration by learning about DNA sequencing, DNA hybridization and the Hardy-Weinberg gene frequency and variation theorem. The objective is to connect the sources to disease patterns within cultural groups. They will discuss and review diseases such as sickle cell anemia and Tay Sachs disease, cystic fibrosis as case studies. Students will then engage in problem solving by conducting research based on a case study on diseases impacting more diverse populations such as multiple sclerosis and cancer. Teams of students with diverse skill levels and experiences will engage in investigative data search and analysis.

One of the most important aspects of the course is that expert resources will be available to confer with students on their projects. Finally, students are encouraged to question and explore.

They are introduced to such engaging resources as *Case It*, a National Science Foundation-sponsored case-based learning project involving molecular biology, computer simulations and



**Figure 6.** The Virtual Cell was designed specifically as a tool for a wide range of scientists. It was developed at the National Resource for Cell Analysis and Modeling at the University of Connecticut Health Center (<http://www.ncam.uhc.edu>) as a unique computational tool that provides a software environment for analyzing, modeling, and simulating cellular function that can range from metabolic pathways to signaling networks to membrane transport and electrophysiology. These models can be based on both experimental data (biochemistry, molecular biology, imaging, etc.) and purely theoretical assumptions by using a very general conceptual structure of a model as a collection of arbitrary processes.

Internet conferencing<sup>60</sup>. The students also are exposed to the Environmental Genome Project sponsored by the National Institute of Environmental Health Sciences, which consider how specific human genetic variations contribute to environmentally-induced disease susceptibility<sup>61,62</sup>.

NSF supported CI/TeraGrid usage is free for such academic exercise. TeraGrid has two important features. It provides the computation power (supported by training) necessary for conducting drug discovery and vaccine developmental research. It also provides a vast amount of scientific information through portals developed for specific type of scientific projects. One can obtain all these information by visiting [www.teragrid.org](http://www.teragrid.org). For computational biology experiments (for the definition, see: <http://www.bisti.nih.gov/docs/CompuBioDef.pdf>), a student can get access to the computing power of TeraGrid through the instructor serving as PI/Principal Investigator. NSF has facilitated this process through Campus Champion Program of TeraGrid (<http://www.teragrid.org/eot/campuschamps.html>). The Campus Champions program supports campus representatives as the local source of knowledge about high-performance computing

opportunities and resources. This knowledge and assistance will empower campus researchers, educators, and students to advance scientific discovery<sup>30,63</sup>. An instructor for teaching CIBRED developed courses will be encouraged to apply for the teragrid computing resources through Campus Champion Program. Being a Campus Champion Program of the National University, AKD will be helping the students for such computing analysis.

Availability of publications in most of the peer-reviewed journals was not free at the individual level, until recently. The student or the instructor needed to visit public or University/institute library to get the access to any printed peer-reviewed publications. Online access was also limited and subscription based. However, recently US Federal Government law passed in December 2008 has empowered the National Institute of Health (NIH) to execute the requirement by all of its grantees who publish articles springing from their govt. funded research to file a copy in PubMed Central (<http://www.pubmedcentral.nih.gov>), a free open access website run by the National Library of Medicine, within one year of its initial publication date. This has made very easy to obtain most of the publications free of charge.

### **Assessment of the Outcome of CIBRED**

The CIBRED assessment for these and other courses will address four research questions derived from a comprehensive list of possible questions. The criteria for selection of those questions included a determination of which are most important to meeting project goals, relevant to the project deliverables and are within the scope of available time and resources. Additional criteria were derived from NSF 02-057 (*The 2002 User-Friendly Handbook for Project Evaluation*). Following those criteria, a document has been generated that identifies the questions and links them to generalized project goals.

An assessment of course readiness will be conducted based on:

1. Accessibility of the network to the collaborators, other institutions and participating student populations
2. Outreach efforts
  - a. What other institutions have expressed an interest
  - b. What type of reaction have other institutions had

- c. CIBRED Web site usage statistics: To disseminate the CIBRED course model, CI courses, and related materials to other participating high schools and colleges via a web-based CIBRED network.
3. The comparative results between the two groups of students completing the courses
    - a. Perceptions and experiences of the course developers, course instructors/educators and participating students
    - b. Comparison of students interests in and perceptions of STEM disciplines before and after completing the courses
    - c. Comparison of students knowledge of team science, transdisciplinary research and CI before and after taking the course
    - d. Comparison of student's ability to participate in team science, transdisciplinary research and CI activities before and after the course taken.

**Importance or relevance to other institutions:**

The CIBRED courses will be offered to two groups of students at each institution. The first group will complete the courses in the Spring, 2009, and the second group in the Fall, 2009. A comparison of results will be conducted to determine course readiness for deployment beyond the participating institutions. Those results will be obtained by surveying the participants before and after taking the course, interviews and feedback from all other stakeholders. The CIBRED Course Model may prove to be an effective and sustainable means for developing CIBRED courses through such collaborative efforts. Later, these courses will be made available for use in other academic institutions evaluating the method of deployment on a case-by-case basis.

**Acknowledgement**

The authors acknowledge contribution through stimulating discussions by various participants of CIBRED, particularly Bruce Sharp of the Virginia Bioinformatics Institute, Tom Klagholz of Klagholz and Associates, Thomas Maccalla of the National University Community Research Institute, Pradip Dey of the School of Engineering and Technology, and Michael Maxwell of the College of Letters and Science, National University. This study is conducted with NSF funding to O. Crasta (OCI-0753375).

## References

- [1]. National Science Foundation (2006). About Office of Cyberinfrastructure (OCI). Retrieved February 26, 2009 from [www.nsf.gov/od/oci/about.jsp](http://www.nsf.gov/od/oci/about.jsp)
- [2]. National Science Foundation (2006). NSF Names Daniel Atkins to Head New Office of Cyberinfrastructure. February 8, 2006, from [http://www.nsf.gov/news/news\\_summ.jsp?cntn\\_id=105820](http://www.nsf.gov/news/news_summ.jsp?cntn_id=105820)
- [3]. Atkins DE, et al. (2003). Revolutionizing Science and Engineering through Cyberinfrastructure: Report of the National Science Foundation Blue-Ribbon Advisory Panel on Cyber - infrastructure. (<http://www.nsf.gov/od/oci/reports/atkins.pdf>)
- [4]. National Science Foundation (2006). NSF'S Cyberinfrastructure vision for 21<sup>st</sup> century discovery. January, 2006, from [http://www.nsf.gov/od/oci/ci\\_v5.pdf](http://www.nsf.gov/od/oci/ci_v5.pdf)
- [5]. McLean, S.A. (2007). Gateway to the TeraGrid for Bioscientists. TeraGrid '07, the second annual TeraGrid conference, June 4 - 8, Madison, Wisconsin. Retrieved Feb 24, 2009 from <http://www.teragrid.org/events/teragrid07/agenda.html>
- [6]. Lathrop, S. (2007). *Education, Outreach and Training (EOT)*. TeraGrid '07, the second annual TeraGrid conference, June 4 - 8, Madison, Wisconsin. Retrieved Feb 24, 2009 from <http://www.teragrid.org/events/teragrid07/agenda.html>; Advancing Scientific Discovery through TeraGrid. TeraGrid '08, the 3rd annual TeraGrid Conference, TeraGrid '08 [www.teragridforum.org/mediawiki/images/8/8f/TeraGrid\\_Overview.ppt](http://www.teragridforum.org/mediawiki/images/8/8f/TeraGrid_Overview.ppt)
- [7]. Madhavan KPC, Goasguen S. (2007). *Integrating Cutting-edge research into learning through Web 2.0 and virtual environments*. Retrieved online February 25, 2009 from <http://library.rit.edu/oajournals/index.php/gce/article/viewFile/94/55>.
- [8]. Barab, S. A., Hay, K. E., Barnett, M., Squire, K. (2001). Constructing virtual worlds: Tracing the historical development of learner practices. *Cognition and Instruction*, 19(1), 47–94; also see: [http://en.wikipedia.org/wiki/Participatory\\_Media](http://en.wikipedia.org/wiki/Participatory_Media) for definition
- [9]. Shapiro, J.J., and SK Hughes, S.K. (1996). Information literacy as a liberal art. *Educom Review*, 31(2): 31; Association of College and Research Libraries (1989). *Presidential Committee on Information Literacy: Final Report*. American Library Association, January 10, 1989, in Washington, D.C. Retrieved February 24, 2009 from <http://www.ala.org/ala/mgrps/divs/acrl/publications/whitepapers/presidential.cfm>
- [10]. Breivik, P. S. & Senn, J. A. (1998). *Information literacy: Educating children for the 21st century*. (2nd ed.). Washington, DC: National Education Association.
- [11]. Bransford, J. D., Brown, A. L., Cocking, R. R. (1999). *How people learn: Brain, mind, experience, and school*. Washington, DC: National Academy Press.
- [12]. Wang, S., and Zhu, X-G. (2008). Coupling Cyberinfrastructure and Geographic Information Systems to Empower Ecological and Environmental Research. *BioScience*, 58 (2): 94-95.
- [13]. Watowitch, S. (2009). Personal communication; also a part of the Figure 1 was retrieved Feb 24, 2009 from <http://www.bmb.utmb.edu/faculty/watowitch/>
- [14]. Rainey, D., Faulkner, S., Craddock, L., Crammer, L., Tretola, B. (2007). *A project-centric approach to cyberinfrastructure education*. TeraGrid '07, the second annual TeraGrid conference, June 4 - 8, Madison, Wisconsin. Retrieved Feb 24, 2009 from <http://www.teragrid.org/events/teragrid07/agenda.html>
- [15]. Barell, J. (2007). *Problem-based learning: An inquiry approach* (2nd Edition). Thousand Oaks: Corwin Press.

- [16]. Duch, B. (2008). *Problem-based learning*. Retrieved, February 10, 2008 from <http://www.udel.edu/pbl/>
- [17]. Kaminski, J. A., Sloutsky, V.M., Heckler, A. F. (2008). Learning theory: The advantage of abstract examples in learning math. *Science*, 320: 454 – 455.
- [18]. Savin-Baden, M. (2003). *Facilitating problem-based learning: Illuminating perspectives*. Buckingham: SRHE/Open University Press.
- [19]. Devine, K., O'Clock, P. and Lyonsc, D. (2000). Health-Care Financial Management in a Changing Environment. *Journal of Business Research*, 48 (3): 183-191.
- [20]. Furic L, Livingstone M, Dowling RJ, Sonenberg N.(2009) Targeting mtor-dependent tumours with specific inhibitors: a model for personalized medicine based on molecular diagnoses. *Curr Oncol*.16(1):59-61
- [21]. Whitfield, K.E., McClearn, G. (2005). Genes, Environment, and Race: Quantitative Genetic Approaches. *By Whitfield, Keith E.; McClearn, Gerald American Psychologist.*, Vol 60(1):, Jan 2005, 104-114.
- [22]. Evans, W.E, Relling, M.V. (2004). Moving towards individualized medicine with pharmacogenomics. *Nature*, 429 (6990): 464-8.
- [23]. Grimaldi D, Claessens YE, Mira JP, Chiche JD. (2009) Beyond clinical phenotype: the biologic integratome. *Crit Care Med*. 37(1 Suppl):S38-49.
- [24]. Individualized Medicine Emerging From Gene-Environment Studies. *ScienceDaily*. Retrieved February 22, 2009, from <http://www.sciencedaily.com-/releases/2005/01/050123213425.htm>
- [25]. Cao Y, Wang N, Ying X, Li A, Wang H, Zhang X, Li W. (2009) BioSunMS: a plug-in-based software for the management of patients information and the analysis of peptide profiles from mass spectrometry. *BMC Med Inform Decis Mak*. 9(1):13.
- [26]. Wing, J.M. (2006). Computational thinking. *Communications of the ACM* 49: 33–35.
- [27]. Sharpe RE Jr, Sharpe M, Siegel E, Siddiqui K. (2009) Utilization of a Radiology-Centric Search Engine. *J Digit Imaging*. 2009 Feb 12 [Epub ahead of publication PubMed: 19214633]
- [28]. Hoffman MA. (2007) The genome-enabled electronic medical record. *J Biomed Inform*. 40(1):44-6.
- [29]. Hunt, K., and Lathrop, S. (2008). *Campus Champions – bringing HPC to your campus* (BoF Topic), Nov 19, in SC08: International Conference on high performance computing, networking, storage and analysis. Austin, TX. Nov 15-21, 2008. Retrieved, November 19, 2008 from [http://teragridforum.org/mediawiki/index.php?title=SC08\\_BoF&printable=yes](http://teragridforum.org/mediawiki/index.php?title=SC08_BoF&printable=yes)
- [30]. Hunt, H., Lathrop, S., Kucera, B., Barr von Oehsen, J., Moye, R., Datta, A. (2009). *Campus Champions – Bringing High Performance Computing to your Campus*. EDUCAUSE 2009 Annual Conference (Panel discussion), Denver, Colorado, November 3–6, 2009.
- [31]. Schneider BS, Higgs S. (2008) The enhancement of arbovirus transmission and disease by mosquito saliva is associated with modulation of the host immune response. *Trans R Soc Trop Med Hyg*. 102(5):400-8; also see: [WHO] World Health Organization. *Dengue*. Retrieved Feb 24, 2009, from <http://www.who.int/topics/dengue/en/>
- [32]. Morens, D.M., Fauci, A.S. (2008). Dengue and Hemorrhagic Fever: A Potential Threat to Public Health in the United States. *JAMA*, 299: 214 - 216.
- [33]. Dey, P., Uhlig, R., Amin, M., Datta, A., Romney, G., Gatton, T., Wyne, M., Cruz, A. (2009a) Teaching Mathematical Reasoning in Science, Engineering, and Technology. *Journal of Research in Innovative Teaching*, Volume 2, *in press*.



- [34]. Dey, P., Gatton, T., Amin, M., Wyne, M., Romney, G., Farahani, A., Datta, A., Badkoobehi, H., Belcher, R., Tigli, O., and Cruz, A. (2009b). Agile Problem Driven Teaching in Engineering, Science and Technology. ASEE/PSW to be held in San Diego, March 19-20, *accepted*.
- [35] Trondsen, E. (1998). *Technology-based learning*. Retrieved February 10, 2008 from <http://www.sric-bi.com/LoD/summaries/LoDRpt01.shtml>
- [36]. Prensky, M. (2004). *Digital game-based learning*. New York: McGraw-Hill.
- [37]. Van, R. E. (2008). *Game-based learning*. *EDUCAUSE Review*, 41(2), 16–30.
- [38]. Bailey, T. R. (2003). *Working knowledge: Work-based learning and education reform*. New York: RoutledgeFalmer.
- [39]. Cunningham, I., Dawes, G., & Bennett, B. (2004). *The handbook of work-based learning*. Adershot: Gower Publishing.
- [40]. Eick, C. J., & Reed, C. J. (2002). What makes an inquiry oriented science teacher? The influence of learning histories on student teacher role identity and practice. *Science Teacher Education*, 86: 401–416.
- [41]. Educational Broadcasting Corporation (2008). *Inquiry-based learning*. Retrieved, February 10, 2008 from <https://www/thirteen.org/edonline/concept2class/inquiry/inde.html>
- [42]. Helic, D., Maurer, H., & Scerbakov, N. (2004). Knowledge transfer processes in a modern WBT system. *Journal of Network and Computer Applications*, 27(3):163–190.
- [43]. George Lucas Educational Foundation (2008). *The Project based learning*. Retrieved, February 10, 2008 from <http://www.edutopia.org/projectbasedlearning>
- [44]. Michaelsen, L. K., Knight, A. B., & Fink, D. L. (2008). *Team-based learning: A transformative use of small groups in college teaching*. Sterling, VA: Stylus Publishing.
- [45]. Lee, M. & Baylor, A. L. (2006). Designing Metacognitive Maps for Web-Based Learning. *Educational Technology & Society*, 9 (1), 344-348.
- [46] O'Neil, H. F., Perez, R. S. (2006). *Web-based Learning: Theory, research, and practice*. Hillsdale, NJ: Erlbaum.
- [47]. Sadikot, R.T., Blackwell, T.S., Christman, J.W., and Prince, A.S. (2005). Pathogen–Host Interactions in *Pseudomonas aeruginosa* Pneumonia. *American Journal of Respiratory and Critical Care Medicine*, 171: 1209-1223.
- [48]. Chambers, T. J., Hahn, C.S., Galler, R., Rice, C. (1990). Flavivirus genome organization, expression, and replication. *Annu Rev Microbiol*, 44: 649–688
- [49]. Rosaura, P., Valle, C., and Falgout, B. (1998). Mutagenesis of the NS3 Protease of Dengue Virus Type 2. *J Virol.*, 72(1): 624–632.
- [50]. Lee, Y.K., Tan, S.K., Wahab, H.A., Yusof, R., Rahman, N.A. (2007). Nonsubstrate Based Inhibitors of Dengue Virus Serine Protease: A Molecular Docking Approach to Study Binding Interactions between Protease and Inhibitors. *Asia Pacific Journal of Molecular Biology & Biotechnology*, 15 (2): 53-59.
- [51]. Wang, E., Ni, H., Xu, R., Barrett, A.D., Watowich, S.J., Gubler, D.L., and Weaver, S.C. (2000). Phylogenetic Analysis of Endemic/Epidemic Dengue Emergence from Sylvatic Progenitors, *J. Virology* 74, 3227-3234; also see, <http://www.bmb.utmb.edu/faculty/watowich/>
- [52]. Kyle, J.L., Harris, E. (2008). Global spread and persistence of dengue. *Annu Rev Microbiol.*, 62:71-92. Review

- [53]. Kyle, J.L., Balsitis, S.J., Zhang, L., Beatty, P.R., Harris, E. (2008). Antibodies play a greater role than immune cells in heterologous protection against secondary dengue virus infection in a mouse model. *Virology*, 380(2): 296-303
- [54]. Avilés, W., Ortega, O., Kuan, G., Coloma, J., Harris, E. (2007). Integration of information technologies in clinical studies in Nicaragua. *PLoS Med.* 4(10):1578-83.
- [55]. Behar, D.M., Rosset, S., Blue-Smith, J., Balanovsky, O., Tzur, S., et al. (2007) The Genographic Project public participation mitochondrial DNA database. *PLoS Genet* 3(6):1083- 1095
- [56]. Stone, L., Lurquin, P. F., and Cavalli-Sforza Genes, L.L. (2007). *Culture, and Human Evolution: A Synthesis*. Blackwell Publishing: MA.
- [57]. Sforza-Cavalli, L.L. (2001). *Genes, Peoples, and Languages*. University of California Press: Berkeley.
- [58]. Well, S. (2002). *The Journey of Man: A Genetic Odyssey*. Random House: New York 2002
- [59]. Cann, R.L., Stoneking, M., Wilson, A.C. (1987). Mitochondrial DNA and Human Evolution, *Nature*, 325: 31-6.
- [60]. Bergland, M., Klyczek, K., Mogen, K., and Johnson, D., Lundeberg, M., Nelson, M.A. (2001). Case It! - a collaborative BioQUEST project to enhance case-based learning in university and high school biology education worldwide via molecular biology computer simulations and Internet conferencing. CAL-laborate Volume 6 June 2001 (Published by: UniServe Science, URL: <http://science.uniserve.edu.au/pubs/callab/vol6/index.html> ).
- [61]. Levin, S.A., Grenfell, B., Hastings, A., Perelson, A.S. (1997). Mathematical and computational challenges in population biology and ecosystems science. *Science*, 275: 334–343 (also see: <http://www.niehs.nih.gov/research/supported/programs/egp/>)
- [62]. Molnar, S. (2006). *Human Variation* (Sixth Edition). Pearson Prentice Hall.
- [63]. Datta, A., Crasta, O., Rainey, D., and Maccalla, T. (2009). *CIBRED- educating Cyberinfrastructure concept and teragrid resources to the 21<sup>st</sup> Century's biological researchers*. EDUCAUSE 2009 Annual Conference (Panel discussion), Denver, Colorado, November 3–6, 2009.

## BIOGRAPHICAL INFORMATION



**Arun K. Datta, Ph.D.**, has double majors in Biochemistry and Software Engineering. As a Director (Technology) of the National University Community Research Institute, he supervises various national and international projects (see: [www.arundatta.info](http://www.arundatta.info)) particularly on healthinformatics. He developed a course on ‘Informatics for Health Professionals’ and now teaches for the School of Health and Human Services (SOHHS). As a Senior Faculty Associate of the National University, he is currently teaching computer science and related subjects in various schools of the University, particularly in the School of Engineering and Technology (SOET). His research interests are: educational technology, health informatics, and protein motif analysis, especially those associated with pathological conditions.

## Is “Dewey’s Experience” Synonymous with the Current Usage of the Term?

Donna M. Schaeffer, PhD  
 Associate Professor, Marymount University  
 School of Business, 2807 N. Glebe Road, Arlington, VA 22207  
 703.284.5718  
 donna.schaeffer@marymount.edu

Patrick C. Olson, PhD  
 Associate Professor, National University  
 School of Engineering and Tech., 3031 Tisch Way, 100 Plaza East, San Jose, CA 95128  
 408.236.1152  
 polson@nu.edu

### Abstract

One of the most amazing aspects of higher education, in nearly all cultures, is that while it is generally viewed as valid or important in at least some context, it generally derives its credibility from the external milieu. Thus if intellect is popular, so is higher education – and visa versa. Importantly, this extends well beyond popularity. It includes aspects of acquiring and valuing knowledge that sometimes have the curious effect of putting higher education in the strange position of placating ideas and beliefs that are known (via research and scholarship) to be wrong. While in some ways this is just a political problem that any organization might encounter – it becomes a problem if the results are curricula that lack integrity and ultimately utility. For many fields the key to this problem is the idea of experience. Additionally, there are two aspects to the issue of experience for many curricula. First is the idea that experience is important and necessary as identified externally (beyond higher education) and the second is the idea that some knowledge may not be gained without experience. The following discusses John Dewey and his work, creates a broad description of the concept of experience in higher education for the purpose of further illuminating the aforementioned problem, and provides an initial attempt at a framework for considering the use of experience in curriculum.

### Introduction

In order to provide aid to those who wish to consider these issues the following steps are planned. First the American Philosopher John Dewey considered this issue for education generally at the beginning of the twentieth century. He is sometimes thought of as the founder of the American Pragmatic School of Philosophy. The first step in this effort is providing the highlights of Dewey’s work in this area with special attention to his book *Experience and Education*<sup>1</sup>.

The second step is a discussion of the current usage of experience in higher education. The intention of this discussion is to anecdotally illustrate how views of experience that are external to higher education can create curriculum integrity problems. A metaphor for this might be the idea that it is nice to be fashionable, but the fact that a Lincoln Versailles was once a popular car does not make it a great automobile. This discussion is needed to provide dimension and clarity for the establishment of a framework.

The third step will be to build and present a framework for dealing with this area. The result will be a two by two matrix. Hopefully, many of the issues and tradeoffs for experience can be brought alive in a visual representation of the ideas.

### Dewey and experience

Some might classify John Dewey as a social scientist. His first work is on psychology, published three years after earning his PhD at Johns Hopkins University. He is a contemporary of Freud (they never met) and is sometimes discussed with Freud and Skinner as representing one of the three approaches to social thought in the United States. Freud and Skinner would represent the other two<sup>2</sup>. The problem with classifying Dewey as just a social scientist is that it is simply not accurate. Dewey's work can be described as at least 25 books spanning 1887 to 1949; and 41 noted pamphlets, essays and other shorter works from the same period. His work can also be described as subjects including psychology, philosophy of education, moral philosophy, ethics, education, logic, democracy and even Leibniz. In fact, by any measure, it is an amazing career. Fairly described, Dewey is a Philosopher. In his works Dewey discusses experience on many occasions, and his philosophy on experience directly relates to our current environment.

One of Dewey's lifelong efforts is the improvement of education. It is likely that Dewey was unimpressed by the educational practices of the late 19<sup>th</sup> and early 20<sup>th</sup> centuries. In fact, he makes the following observation in 1902;

*The source of whatever is dead, mechanical, and formal in schools is found precisely in the subordination of the life and experience of the child to the curriculum.*<sup>3</sup>

This is a good introduction to what Dewey's concern with experience is about. In effect, he observes that we learn by experiencing. His observation for education is that the system in existence at the time of his work is based on an important fallacy. This is that the experiences designed by adults – and particularly to be credible to adults – to teach children were failing. Further, they were failing because these experiences assumed that the child's experience would be the same as the adult's experience.

As one might assume, this is a liberating idea for professional educators. Of course like many liberating ideas, the liberation soon began to resemble anarchy. To get an idea of how this might have looked in the 1920's, one can view the play or movie *Auntie Mame*. The title character is left to raise her nephew and chooses several avant-garde schools for him, until this is curtailed by the executor of her brother's estate.

Dewey was not a proponent of this approach. In fact, he indicates that these efforts were also based on fallacy. That is "experiences" alone – without any vision will not produce an educated person. He spends a significant portion of *Experience and Education*<sup>1</sup> addressing this problem.

So, what is experience? The idea is, in effect, the interaction of a learner and its environment<sup>4</sup>. While this is good news to those who like to advocate a hands-on approach to teaching and learning, it is more complicated in practice.

### Current experience issues

One issue that Dewey did not discuss is the impact of the growth of knowledge. In effect, thanks to the “information explosion” there are two additional problems. First, what set of knowledge is appropriate for a “college educated” person in our times. Secondly, education, particularly higher education, is bigger. This is partly due to the information explosion – but raises questions about issues such as a single approach to all of the subjects in higher education. Finally, there are more expectations on higher education – and credibility (the problem first encountered by Dewey) is more important than ever.

The problem for much of higher education is restated as the credibility of graduates. In effect, a program is considered good if it is credible with external validation. Of course a well known approach to this problem is to require more background of the students when they are admitted. Many MBA programs require five years of business experience before one can be admitted to the program. This certainly makes the graduates credible, but the nagging question that remains is what did they learn in the program that they did not already know?

There is also a problem for knowledge that “must” come from interacting with the artifact. While this would definitely be knowledge gained from experience, and something Dewey would likely endorse, what happens if the experience is not credible? This is often witnessed in computer programming. What is the best approach to teaching programming? There have been groups that advocate that you use a language that is designed to teach programming. Others advocate that you teach a language used by a relevant community to help the students adapt to that community. While this might seem minor – consider the idea that there are computing programs in existence in the United States that taught COBOL and only COBOL for more than twenty-five years. Also consider the idea that there is a body of discussion about how COBOL is the worst language to use for teaching programming. Who was right is not a matter for this paper, however, the question “Would COBOL have been an introduction to programming language in any program if it were not for the availability of external validation?” is an important question.

### Framework

From both the work of Dewey, and the experiences of our own times two aspects of experience appear as very important. The first is the hope of experience that will increase knowledge. The second is the idea of the experience being credible with some external validation. This seems like an ideal application for a 2x2 matrix<sup>5</sup>, along one axis increasing knowledge and along the other increasing credibility.

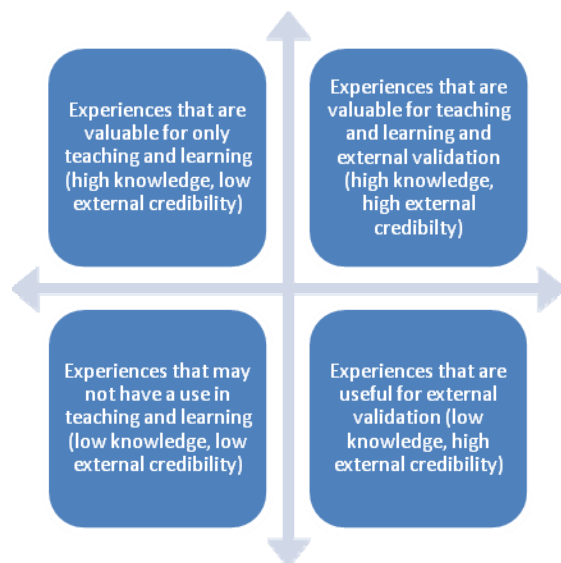


Figure 1 - A 2x2 Matrix of Knowledge and Credibility

The quadrant that has experiences that are likely to require the most attention is the upper right. These are experiences that both increase knowledge and increase credibility. An interesting example of such an experience in programming might be competing in (and perhaps winning) an interschool programming competition.

The most difficult quadrant for teaching and learning is the lower right. In that quadrant the experience has high external credibility and has a low potential for increasing knowledge. A programming example (for the sake of programming and not other purposes) might be building WEB sites for an external organization. This is very likely to have high external credibility (and could even earn some publicity), however, the likely increase in programming knowledge is low.

Another difficult quadrant for teaching and learning is the upper left. In that quadrant the experience has a high potential to increase knowledge, and a low potential for external credibility. An example from programming might be the use of the Scheme programming language. This choice is likely to provide several advantages for teaching and learning, however, it is unlikely to have an external interest. This is particularly the case if there is no external user of the language near where the language is taught.

The last quadrant on the lower left appears easy. These experiences do not have much potential to increase knowledge, and do not have much credibility. A programming example might be teaching an application – for example Power Point. This is unlikely to increase knowledge about programming, and is unlikely to have external credibility for programming. Interestingly, this can happen.

The most likely use for this framework is to provide a means of classifying experiences. However, this can also be used to balance experiences – particularly making sure that most of the experiences increase knowledge. Additionally, the increase must make sense in terms of the development of the student.

## Conclusion

The intended outcome is a guide for this issue. Thus, those that are on occasion confronted with these issues have a quick reference resource to at least help in formulating questions for a refined discussion and perhaps an improved situation in their domain.

This work is mainly intended to aid curriculum discussions. However, given both the growth of knowledge and the observations made by E. O. Wilson in *Consilience: The Unity of Knowledge*<sup>6</sup> this is particularly important in those instances where disciplines must combine and cooperate for the purpose of building new knowledge! Thus, academic and nearly all knowledge workers could find a utility in this discussion.

## Bibliography

1. **Dewey, John.** *Experience and Education*. London and New York : Macmillan, 1938.
2. *Dewey and Freud.* **Seckinger, Donald and Johanna Nel.** Jackson, WY : ERIC ED379181, 1993. Annual Meeting of the Northern Rocky Mountain Educational Research Association. p. 7.
3. **Dewey, John.** *The Child and the Curriculum*. Chicago : University of Chicago Press, 1902. p.14
4. **Strathern, Paul.** *Dewey in 90 Minutes*. Chicago : Ivan R. Dee, 2002. p.40
5. **Lowy, Alex and Phil Hood.** *The Power of the 2 x 2 Matrix: Using 2x2 Thinking to Solve Business Problems and Make Better Decisions*. San Francisco : Jossey-Bass, 2004.
6. **Wilson, E. O.** *Consilience: The Unity of Knowledge*. New York : Knopf, 1998.

## Biographical Information

Donna M. Schaeffer, PhD is currently an Associate Professor of Information Systems at Marymount University in Arlington, Virginia. She earned her PhD in MIS at the Claremont Graduate School in 1996 – with a cognate minor in Higher Education. She has an MBA from Florida International University. Her undergraduate degree is also from FIU. She has held faculty positions at the University of San Francisco, and the University of Redlands.

Patrick C. Olson, PhD is currently an Associate Professor of Computer Science at National University. He earned his PhD in MIS at the Claremont Graduate University in 1999 - with a cognate minor in Higher Education. He has an MS from USC in Systems Management with a minor in MIS. His undergraduate degree is from the University of Montana. He has held faculty positions in MIS at the University of Nevada and Cal Poly, Pomona.

## **INTEGRATING DESIGN APPLICATION AND COMMUNICATION SKILLS INTO SENIOR DESIGN COURSES**

James Helbling, Department of Aeronautical Engineering  
Embry-Riddle Aeronautical University, Prescott, AZ

This paper recounts the evolution of a capstone senior design course taught at Embry-Riddle Aeronautical University in Prescott, Arizona. It will discuss the development of the application based learning objectives and the integration of a technical communication component into the course in question, and the challenges and negotiations involved in successfully implementing these changes in course content.

The content of this aircraft design course was conceived after a review of previous senior design briefings and of recent alumni surveys. The design briefings were shown to be lacking in any true understanding of physical application of analytical tools, while the alumni survey indicated that the students were given insufficient communication training during their tenure at the university. As a result, the course content was radically altered to address these perceived weaknesses.

To address the lack of application of analytical tools, both wind tunnel and structural testing of scaled aircraft models were introduced into the course. The wind tunnel models were used to verify the aerodynamic loading and stability predictions made during the preliminary design phase completed in a prerequisite design course. Structural testing was then completed to verify the design team's ability to predict structural response to load completed via finite element model simulation. Further design verification has recently been added in the form of flight testing of scaled flight test articles designed to fly with RC components.

The lack of communication training was addressed by introducing team-teaching with a communications instructor. This instructor provides lectures and additional guidance in the areas of technical writing, group presentations, and teamwork. The instructor is responsible for 30% of the grade for all written and oral communication submittals.

The integration of design application and communication skills has been very successful in preparing Embry-Riddle students for real world employment as evidenced by alumni comments. Senior students also enjoy being placed in a hands-on environment which allows verification of the theoretical learning they have been exposed to during their previous courses.

### **Introduction**

This paper recounts a change in the senior capstone design curriculum at Embry-Riddle Aeronautical University (ERAU)/Prescott campus that involves the introduction of verification of analytical predictions via testing of physical models and a team-teaching effort between the Department of Aeronautical Engineering (AE) and the Department of Humanities/Communities (HU/COM). These changes address perceived gaps in student preparation as they transition to the workplace. This paper will define these perceived gaps in student knowledge, describe the implementation of curriculum changes, and evaluate the success of the new capstone curriculum.



The senior capstone Aircraft Detail Design course was selected for curricular change because it provides timely instruction just prior to graduation. Furthermore, this course is intended to be a stepping stone to professional life. Thus, curricular changes to bolster application of theory and communication skills, including teamwork and conflict resolution, have been implemented in order to better prepare senior students for professional challenges.

This paper begins by explaining the context that led to the curricular changes in the capstone course. The evolution of the Detail Design course is described in detail, followed by a discussion of the challenges and successes encountered in developing revised course content. The paper concludes with a recap of the recent physical enhancements in the course configuration and plans for further improvements in preparing ERAU graduates for their post-graduate life.

## **Context**

ERAU/Prescott is a 4-year university in Northern Arizona with an enrollment of approximately 1,600 undergraduate students, with Aerospace Engineering (AE) being the most popular engineering major. Students majoring in AE take courses which have a strong emphasis on laboratory and design work to prepare the students for the senior capstone design courses.

AE majors must choose one of two design tracks: aircraft or spacecraft. The aircraft track culminates in a sequence of two senior design courses: Aircraft Preliminary Design and Aircraft Detail Design. Likewise, the spacecraft track also has two senior design courses: Spacecraft Preliminary Design and Spacecraft Detail Design.

In the Aircraft Preliminary Design course, students work in teams to conceptualize a complete aircraft design. These designs are developed in response to a set request for proposal (RFP) which defines mission requirements and aircraft constraints. In the Aircraft Detail Design course, teams have the option of pursuing a design, build, fly (DBF) design or selecting one component – typically a wing or tail section – and designing a scaled test article representative of that component which they will ‘design, build, and break’ (DBB).

All teams fabricate full aircraft wind tunnel models for the purpose of verifying the aerodynamic loading and stability characteristics of their designs that they predicted in the Preliminary Design course. All teams also perform structural testing to verify finite element simulations of their designs. The DBF teams test to 80% of design limit load, while the ‘design, build, break’ (DBB) teams test their selected component test articles to failure. These design and test results are then presented by each team at a formal briefing at the end of the semester. This formal briefing is open to the university and is scored by a panel consisting of faculty and members of the university’s Industrial Advisory Board (IAB).

All of the senior design courses have significant technical writing and team presentation components. To prepare for these senior design courses, all AE students must take (and pass) a Technical Writing course and a Speech course. These writing and speech courses are offered by the HU/COM department.

Six years ago the Aircraft Detail Design course underwent a curricular update to better prepare AE students for professional life. The results from annual internal reviews were documented in preparation for a program review by the Accreditation Board for Engineering and Technology (ABET) in addition to the results from alumni surveys. These results indicated that AE graduates required more intensive and timely preparation in two primary areas: application and communication.

The impetus for a more application-based curriculum came from a change in faculty at the Detail Design level. The new design faculty had many years of industrial and managerial experience prior to joining the ERAU staff and understood that typical undergraduate training does not emphasize the application of theory. To address this need, the Aircraft Detail Design course added the fabrication of test models to allow verification of analytical predictions. The Detail Design instructor now also engages in team-teaching with his Preliminary Design counterpart to ease the transition from the more theoretically-based curriculum to his application-based course.

To address the lack of adequate communication instruction, the AE faculty reached out to the HU/COM faculty. After a series of discussions and negotiations, the AE and HU/COM faculty decided to implement communications team-teaching in selected senior capstone courses. This arrangement is explained more fully in the following section.

### **Aircraft Detail Design Course Evolution**

The ERAU senior design courses are required 4-credit classes, taken in the senior year, that allow students working in teams of typically 6 to 8 members to design an aircraft or spacecraft and then test one component or set of subsystems. Extensive written reports and formal oral presentations are required in each course.

Prior to the curricular changes discussed in this paper, the Aircraft Detail Design course involved minimal wind tunnel testing and the limited involvement of an HU/COM instructor who served in strictly an advisory role. The change in the course content addressed perceived weaknesses through: 1) additional verification of analysis via test and 2) an increased emphasis on communication skills.

The first curricular change required students to select a single component from the aircraft they developed in the preliminary design course and concentrate on the design of that component alone. They were first required to fabricate and test a wind tunnel model of the selected component, with the intent of determining coefficient data that would allow verification of the aerodynamic coefficients derived during the preliminary design process. The students then used the coefficient data to verify loads predictions for the component being designed.

Concurrently, students designed a scaled structural model of their chosen component to critical design loads (verified by the wind tunnel results). Since the structural model was scaled, an emphasis was placed on verification of analytical method versus design of the full-scale component. Students were required to simulate their structural model as it was actually built and constrained using a Finite Element Model, and then verify their ability to predict structural

failure by comparing strain and deflection measurements obtained from the actual model to those predicted by the computer simulation.

The second curricular change adopted a team-teaching approach utilizing HU/COM faculty to provide lectures to students on proper technical writing style and the expected content of written submittals. This collaboration has been shown to benefit students in at least two ways: 1) to provide supplementary instruction in communication skills and strategies that are immediately contextualized making them more easily grasped<sup>2</sup>, and 2) to present the rhetorical tools that allow students to master the genres specific to their discipline (e.g., design proposals) which AE instructors have mastered but may have difficulty articulating<sup>3</sup>.

The HU/COM faculty member scored both written and oral submittals and also provided lectures on improving team interaction skills, which had always been a problematic issue within the design teams. She also developed a Code of Conduct and Conflict Resolution Plan, which were adhered to by all teams, and which have proven to be very effective in eliminating unprofessional behavior and promoting a healthy environment within the teams.

Recently, the course took on a different track by introducing the DBF option. This option is now initiated in the Preliminary Design course where two design teams are provided identical RFP's in the form of a design competition which culminates in the Detail Design course as a wind tunnel 'fly-off'. The two Preliminary Design teams combine to form a single team of 12-16 students in Detail Design. The two former teams become 'design groups' which continue to develop their designs through the fabrication of full aircraft wind tunnel models making use of rapid prototyping wherever possible<sup>4</sup>. The models are then tested using identical procedures and the results are submitted to a faculty panel which then selects the design which appears to have the most promise as a flight test article. Teams which choose this option still have the requirement to perform structural test of a selected component (typically a wing) to verify a finite element simulation, however they do not test to failure. The DBF teams instead perform a 'proof' test to 80% of the predicted limit load so that their component can be used for their flight test article. It should be noted that the flight portion of the design is purely optional, with the potential of 'bonus' grade points being part of the incentive provided to students to complete the flight test.

Introducing this option created new challenges in terms of communication and conflict resolution. With the combination of two teams into one, the design groups were forced to collaborate in the writing of their report sections so that a uniform product was submitted. There was also the obvious feeling of loss that one design group was forced to experience when the project that they had been dedicated to for over four academic months now had be 'left behind'. These factors made the need for communications and conflict resolution assistance offered by the HU/COM co-instructor even more essential to the successful completion of the project.

Based upon the improved quality of student written work, positive feedback on student course evaluations, positive comments received from ABET auditors, and improved alumni survey results, the curriculum changes cited above have become engrained in the Aircraft Detail Design course. However, implementing this curricular change did not come without its challenges, which are further documented below.

## Challenges

Two critical challenges resulted from the implementation of this curricular change, primarily in the area of HU/COM team-teaching. The first critical challenge was student resistance to having an HU/COM professor in their AE class. When the HU/COM instructor was first introduced to the students in the team-teaching position, the students were uncertain of her role. They were unsure as to the relevance of her presence and what value she would add to an engineering course.

Despite providing a course syllabus which highlighted communication and teamwork objectives and activities, and despite the HU/COM instructor's lectures that were designed to ease the documentation process, in the first semester of the curricular redesign process AE students did not see the value of having a communication instructor in the classroom. Some even argued that her lectures on documentation and presentation were taking time away from the real work of the class, which they perceived was solving, designing and testing, not documenting. Students felt this way despite both instructors' consistent emphasis during class time on the need for strong communication and conflict negotiation skills if students were to be successful in industry,

The source for this lack of respect given to the HU/COM instructor was traced to lack of grading authority. In a traditionally team-taught course, grading authority is negotiated between instructors and is dependant upon the content and context of the course. In this case, team teaching was new to ERAU and so the HU/COM instructor did not immediately negotiate any grading authority; without such authority, however, students did not perceive the communications faculty as being a "real" teacher in the class, which lead in turn to student resistance to lecture material and instructor comments and requests for revision.

Therefore, in response to this challenge, the two instructors re-negotiated the syllabus so that the communications faculty would help assess every assignment and would then assign some percentage of the total points for that assignment. As a result, while the majority of the assignment grade would still be based on content and technical accuracy, a lesser percentage would be allocated to format, coherence, and grammatical accuracy.

Student response to this change in policy has been very positive. Once they realized that the communications instructor was grading the quality of their work, students began to treat her as a useful resource. Team teaching was subsequently introduced in the Aircraft Preliminary Design which made students even more accepting of the team teaching arrangement in Aircraft Detail Design. In fact, after a few semesters, students have begun to expect HU/COM instructors in their senior design courses, and first-year engineering students already know which HU/COM faculty is teaching in which AE senior design course.

While the first critical challenge was classroom related, the second critical challenge is more administrative in nature. To understand the nature of this challenge, one must also understand that as an undergraduate teaching institution, ERAU has many degree programs but none that are housed in the HU/COM department. Rather, HU/COM is a service department, teaching general

education courses such as freshman composition, speech, journalism, literature, values and ethics, mythology, and basic humanities courses to approximately 1600 students. As such, this department offers a broader range of courses and more sections of courses than any department on campus except the flight department, and accomplishes this feat with a limited number of full-time faculty and adjuncts.

Obviously, faculty resources can become a bit stretched, and HU/COM faculty have at times been asked to stop team-teaching with the AE faculty in order to teach general education courses instead. As of this semester, department chairs in both departments have been able to juggle faculty and course loads to satisfy administrative requirements so that HU/COM may continue to support the AE students' professional development. And many administrators see the value of the continuing collaboration between departments, for both teaching and research. Nonetheless, varying levels of administrative support for team teaching is a continuing challenge for ERAU/Prescott, one that might be side-stepped by in the short term by mini-grants or adjunct hires, but one that must be addressed each semester that this curricular redesign continues.

## Successes

Although a quantitative assessment of the success of the capstone curriculum change is difficult at this time due to limited data, a qualitative appraisal is possible based upon student course evaluations, senior exit interviews, feedback received from a recent audit performed by ABET, and recent alumni feedback.

The percentage of positive student comments documented in course evaluations has increased steadily every semester since the capstone curriculum change was introduced in Fall 2003. Initially students were frustrated by the changes made to the course and the workload required to achieve the course objectives. This frustration resulted in less than 50% of the comments regarding the course content being positive. During the last 8 semesters, however, 80 – 90% of the comments are routinely supportive of the course.

Regarding the application-based learning content, student comments during the first two semesters were directed toward the time 'taken away' from analysis and design work by forcing them to manufacture test articles. Many of these comments referred to the fabrication tasks as non-engineering work. However, comments received during the last 8 semesters have embraced the learning experience inherent in manufacturing a test article, and the design 'lessons learned' obtained through fabrication and test. The positive comments now routinely outnumber the negative responses in excess of 10:1.

In terms of team-teaching, originally only one or two students would provide positive comments regarding the communications instruction given. Those comments now routinely number 10 or more for class sizes ranging from 15 to 30 students. Originally there were many comments asking why time was being 'wasted' on communications skills that could be provided adequately by the engineering instructor. The comments now typically state the students' gratitude for the work ethic shown by the HU/COM instructor in improving their communication skills.

Overall, students greatly appreciate the opportunity to perform application-based engineering, and enjoy having a faculty member dedicated to improving their HU/COM skills. There have been many positive comments on the structure of the course and the HU/COM instructors' willingness to provide almost immediate feedback on written assignments, and on how incorporating that feedback into report sections throughout the semester makes the final compilation of design reports much less difficult and stressful. Seniors have also voiced their overwhelming approval of the structure and learning environment present in the Aircraft Detail Design course in senior exit interviews documented since the curriculum change.

The ABET auditors were impressed with the AE Department's strategy in addressing application-based engineering and in adopting team-teaching to further improve communications skills, which was documented as a perceived weakness in recent alumni surveys. The ABET criteria require engineering programs to show that graduating students have computer simulation and experimental experience as well as communications and ethics skills and have demonstrated the use of that skill set to enhance the technical content of their curriculum. The application-based engineering approach and team-teaching with communications faculty as a part of the senior design experience certainly helps to fill these requirements, and the auditors wholeheartedly endorsed the process.

Additionally, alumni surveys have shown a reversal of the previous trend showing dissatisfaction with technical writing and project management skills acquired at Embry-Riddle's Prescott campus, as shown in the following table.

<b>Skill Preparation</b>	<b>1999 - 2002 % Very Good Responses</b>	<b>2004 % Very Good Responses</b>
Technical Writing	28.4	50.0
Planning, Scheduling and Carrying-out Project	22.0	57.4

The table shows the percentage of 'One Year Later' alumni respondents who indicated they received a 'very good' preparation for the two general skills most closely linked to the curricular change implemented in the capstone design course. The center column shows the results for a compilation of the surveys taken for the three years prior to the curricular change, while the right column shows the results for the year following the initial curricular change (which is also the latest available data for this type of survey). These results show a dramatic improvement in perceived alumni preparation which is likely attributed to the timely communication and team-building skills emphasized in the capstone course. However, it is understood that these data are provided for a limited time period and scope, and further verification of these results is required.

While no formal survey data are available for more recent years, a qualified assessment of the curricular changes is available through alumni feedback via email transmissions. Since 2004, a semester has not gone by without several alumni contacting both the engineering and communications instructors of the Aircraft Detail Design course to personally thank them for exposing the alumni to analytical verification methods and 'forcing' them to learn proper communication skills. These students often cite the documentation and presentation requirements of industry,

and state how much better prepared they are for those requirements versus recent grads from other institutions.

## Planned Improvements

As stated in previous paragraphs, the Aircraft Detail Design course allows students to gain first-hand knowledge of analysis verification via test. This environment has been greatly enhanced with the recent addition of an Aerospace Fabrication and Experimentation building which allows for structural testing using industry standard equipment<sup>5</sup>. This new building also includes separate fabrication areas for both the aircraft and spacecraft design teams placed on either side of a refurbished machine shop with computer-numeric-controlled machining capability. These facilities allow students to fabricate and test their designs more efficiently and with a higher level of fidelity than was ever before possible. However, even with these physical enhancements to the ERAU/Prescott capstone experience, several improvements are planned which will allow future students to become even more prepared for their post-ERAU futures.

The curricular changes described in this paper are planned for implementation into the Spacecraft Detail Design course in the Fall 2009 semester. Once this course has undergone curricular modification, all four senior design courses will provide AE graduates with timely instruction on application of engineering theory and with a stronger set of team, communication, and ethics skills. Because these objectives will be present in all four classes, and because all four courses will use the same delivery method (i.e., team-teaching), these classes will form a coherent curriculum. Students will have established the required skills in their preliminary classes and can thus transition more easily into their detail courses where these skills will be refined in preparation for professional life.

Finally, it is planned that follow-up alumni surveys and additional quantitative data be collected which will be used to assess the success of this curricular modification. This information will also be used to identify additional skill sets that could be incorporated in future curricular modifications intended to better prepare AE graduates for professional challenges.

## References

- <sup>1</sup> Helbling, Jim, David Lanning, Ron Madler, Angela Beck, and Patric McElwain. "Integrating Communications into Team-Taught Senior Design Courses" Proceedings of the 2005 American Society for Engineering Education Annual Conference and Exposition, Washington DC: ASEE, 2005.
- <sup>2</sup> Bereiter, Carl and Marlene Scardamalia. The Psychology of Written Composition. Hillsdale, NJ: Lawrence Erlbaum, 1987.
- <sup>3</sup> Kokkala, Irene and Donna A. Gessell. "Writing Science Effectively." Journal of College Science Teaching 32 (2003): 252-257.

- <sup>4</sup> Helbling, Jim, and Lance Traub. "Impact of Rapid Prototyping Facilities on Engineering Student Outcomes" Proceedings of the 2008 American Society for Engineering Education Annual Conference and Exposition, Pittsburgh, PA: ASEE, 2008
- <sup>5</sup> Helbling, Jim, David Lanning, Ron Madler, Darin Marriott, and Karl Siebold. "Impact of New Facilities on Engineering Student Outcomes" Proceedings of the 2007 American Society for Engineering Education Annual Conference and Exposition, Honolulu, HI: ASEE, 2007.

## **Biography**

JAMES F. HELBLING, M.S.A.E.

Currently an Associate Professor of Aerospace Engineering at ERAU/Prescott where he teaches structural analysis, computer aided design, and aircraft detail design courses. He has 21 years of industry experience with McDonnell Douglas (now Boeing) and Northrop Grumman Corporation where he specialized in structural fatigue loading and served as manager of F-5/T-38 Engineering.



# The Integration of Ruby on Rails As An Agile Teaching Tool in IT Curricula

Gordon W. Romney

National University, 3678 Aero Court, San Diego, CA 92123, U.S.A.

## ABSTRACT:

Ruby on Rails (RoR) is an extensive framework of Model-View-Controller (MVC) architecture comparable to Java's use of Tapestry and Struts and Microsoft's .NET frameworks. The ease of its use and productivity make it an obvious choice for agile web development that is being confirmed in the web marketplace. Its ease of use made it a prime candidate for trial training of Information Technology (IT) students for multiple technology purposes beyond just web development. RoR has proved to be a multi-faceted agile teaching tool in IT courses from an elementary to very advanced level. It is database agnostic and allows students to easily switch databases from MySQL to MS-SQL and Oracle and experience an immediate comparison virtually impossible with other frameworks. It functions ideally under virtualization and in this context is the perfect tool for working under both Windows and Open Source environments and in being the vehicle for implementing problem-focused learning scenarios. Of equal importance, RoR teaches proper application development formality using the RESTful approach that increases performance and resilience and reduces latency. RoR ease of use by students to learn quite different IT skills is demonstrated in introductory IT, database, security and Web system architecture courses.

Key words: Agile, Agile Teaching, Problem Based Learning, Problem Driven Teaching, Agile Problem Driven Teaching, Agile Programming, Agile Software Development, Agile Project Development, Ruby on Rails

## 1. INTRODUCTION

IT educators are challenged to remain current in a dynamically changing technology environment and a knowledge-based economy. Providing beneficial instruction in current technology to IT students at an increasingly accelerated pace is demanding and challenging, but "a lot of fun." National University (NU) has an advantage over many other institutions of higher learning in that its teaching model is based on "one-course-per-month", its students are largely employed in industry, and the instructors are "up to date" with current technology because the majority are simultaneously employed in the IT industry. The majority of the students, likewise, are IT professionals, bringing with them many advanced skills, and are highly motivated toward obtaining a degree in order to advance in their profession. At NU the BS IT Management (ITM) program offers classes both in-person and on-line. Specific challenges of the NU teaching model, as they apply to IT, are its accelerated pace, long instruction class periods, the lack of the traditional laboratory experience and the increasing demand for on-line instruction. The transition of industry toward using Agile ("ease of movement") techniques in programming and project development has motivated the faculty at the National University (NU) School of

Engineering and Technology (SOET) to introduce agility into pedagogy. Agile Problem Driven Teaching (Dey et.al., 2009) as used in teaching IT is described in this paper.

### 1.1 The IT Industry Evolution Toward Agility

It has been fascinating to watch the evolution of IT project management (PM) from the rigid structure of the 60's through the early 90's to the triple-time paced agility of the Internet era. The pace of change has accelerated phenomenally and the current IT manager is under "ever-increasing pressure" to produce quality product even in circumstances of reduced development budgets. In an attempt to keep pace with change, Agile Programming (AP) techniques were introduced by various developers but 2001 signaled the date of the "Manifesto for Agile Software Development (ASD)" (Agile Manifesto, 2001). The ASD Manifesto states:

"We are uncovering better ways of developing software by doing it and helping others do it. Trough this work we have come to value:

- Individuals and interactions over *processes and tools*
- Working software over *comprehensive documentation*
- Customer collaboration over *contract negotiation*
- Responding to change over *following a plan*

That is, while there is value in the *items on the right*, we value the items on the left more."

Dave Thomas (Thomas, 2005, 2007) and Martin Fowler, two of the creators of the ASD Manifesto, are noted Ruby on Rails developers. An Agile Project Management (APM) framework that uses AP and helps move from chaos to order was proposed by Jim Highsmith (Highsmith, 2004), another contributor to the ASD Manifesto. Raising a project manager from the level of "uninspired taskmaster" to that of "visionary leader" can effectively be achieved by employing APM (Cspace, 2009). Additional perspectives on APM as applied to IT projects are provided by Alleman (Alleman, 2002, 2009).

### 1.2 National University as an Agile Incubator

Instructors at NU increasingly have been introducing agile concepts into undergraduate and graduate instruction. In ITM courses this was done by the author in order to meet the specific NU challenges specified above. Additionally, it is being done as IT tools have developed in the marketplace based upon the Agile concepts introduced in both AP and APM. Ruby on Rails (RoR) development framework is one of these tools. The author has used RoR as such a tool in two different university settings for the past four years. As RoR has been deployed it becomes self-evident that APM is introduced into the projects that use RoR. The net results are Agile teaching solutions that meet the specific NU challenges. RoR introduces Agile Programming, projects demand Agile Project Management, and the introduction of problems in class assignments leads to Agile Problem Driven Teaching (APDT). APDT effectively uses APM and the agile tools like RoR and simultaneously trains the students to use AP and APM concepts in their workplace.

### 1.3 How Agility Addresses the National University IT Teaching Challenges

Specific challenges of the NU teaching model as they apply to IT are 1) its accelerated pace, 2) long instruction class periods, 3) the lack of the traditional laboratory experience, and 4) the increasing demand for on-line instruction. Many IT concepts are best learned by many students through “hands on learning” (HOL) (Crowley, 2003). The absence of a laboratory experience and the ever-increasing percentage of on-line instruction severely handicap the student who learns best from HOL.

#### 1.3.1 *The Need for Virtualization*

The development of a transportable lab (referred to in this paper as a Virtual Lab) that can be used both inside and outside of class begins to replace the lack of a physical laboratory with all of its supportive technology. The Virtual Lab uses virtualization software installed on a USB connected hard drive in excess of 10 Gbytes supplied by the student. The Virtual Lab is even used in selective on-line courses. The virtualization software used has been both Microsoft’s Virtual PC and VMware and their respective virtual machines. Virtual machines (VM) typically consist of an operating system and associated application software. It is normal for an instructor to provide a VM to the class that presents the problem to be solved in an already operational computer environment. Hence, students are not constantly building and rebuilding the base computer environment used to present the specific problem. Virtualization saves many hours spent in the traditional lab repeating previous effort to simply create the base computer environment. Frequently, in the traditional lab, some students never even get to begin solving the assigned problem because of having to initially first restore a system to a useable configuration.

A student particularly appreciates the fact that she can receive a VM from her instructor, install it on her USB drive and execute it from her laptop without interfering with the resident build on her laptop or desktop at home, or the classroom workstation that is constantly used by sequentially scheduled classes. In Windows environments this means her registry does not get modified in order to check out this new VM the instructor wants her to work with. If she messes things up, only the VM space and not her entire laptop is affected. The ability to work with a VM outside of class is significant for experiential learning. HOL is restored to all students. Virtualization is a powerful tool that helps resolve all four of the NU IT challenges.

#### 1.3.2 *Virtualized RoR Facilitates Agility*

The Ruby on Rails (RoR) framework, as a tool for Agile Teaching, helped introduce by example a multitude of IT concepts that were used in the most elementary ITM course, ITM 320, and then used throughout the entire ITM program instruction including the most advanced training for the ten CISSP security domains (Harris 2008). Web development with RoR is considered to be “agile web development” (Thomas 2007) and follows the AP and APM concepts. Agile RoR actually accelerated IT teaching and helped more successfully to include all the material required in the NU model of “one-course-per-month.” Beginning students in ITM 320 prepared their Virtual Lab USB drive that was used in subsequent 300 and 400 series classes. In ITM 320 they received a VM that included a RoR build that operated under Windows XP and actually put a

web server and database server through its paces serving up browser pages. Components of a web system began to take life in their own Virtual Lab. These same students over a year later built upon their initial elementary experience and used RoR in advanced security configurations. Combining RoR with virtualization (VRoR) led to the creation of many lab experiments that will be presented in Section 4, Agile Problem Directed Teaching using VRoR.

## 2. RUBY ON RAILS (ROR)

Ruby on Rails is a combination of Ruby, a programming language (Fulton 2006), and Rails, a web support framework (Holzner 2007). An application development framework delivers working software early in the development cycle. Rails, as an agile framework, encourages developer and customer collaboration (Thomas 2007). Instant Rails is a preconfigured, ready to run software solution containing Ruby, Rails, Apache (web server), Mongrel (Rails development web server) and MySQL (a relational database system) (Instant Rails, 2009). This runtime version does not modify the base system configuration for Windows, OS X and Linux environments. Instant Rails version 2.0 was used in the projects described in this paper and facilitated an instant installation of a working RoR system, even for a neophyte IT student.

Ruby is an interpreted, object-oriented programming (OOP) language. It is a radically object-oriented “pure” OOP language in that every entity in the language is an object, every primitive type is a full-fledged class, and both constants and variables are recognized as object instances. It is agile as it may be extended and encourages easy refactoring (Fulton 2007). Ruby on Rails is based on the Model View Controller (MVC) architecture shown in Figure 2.1.

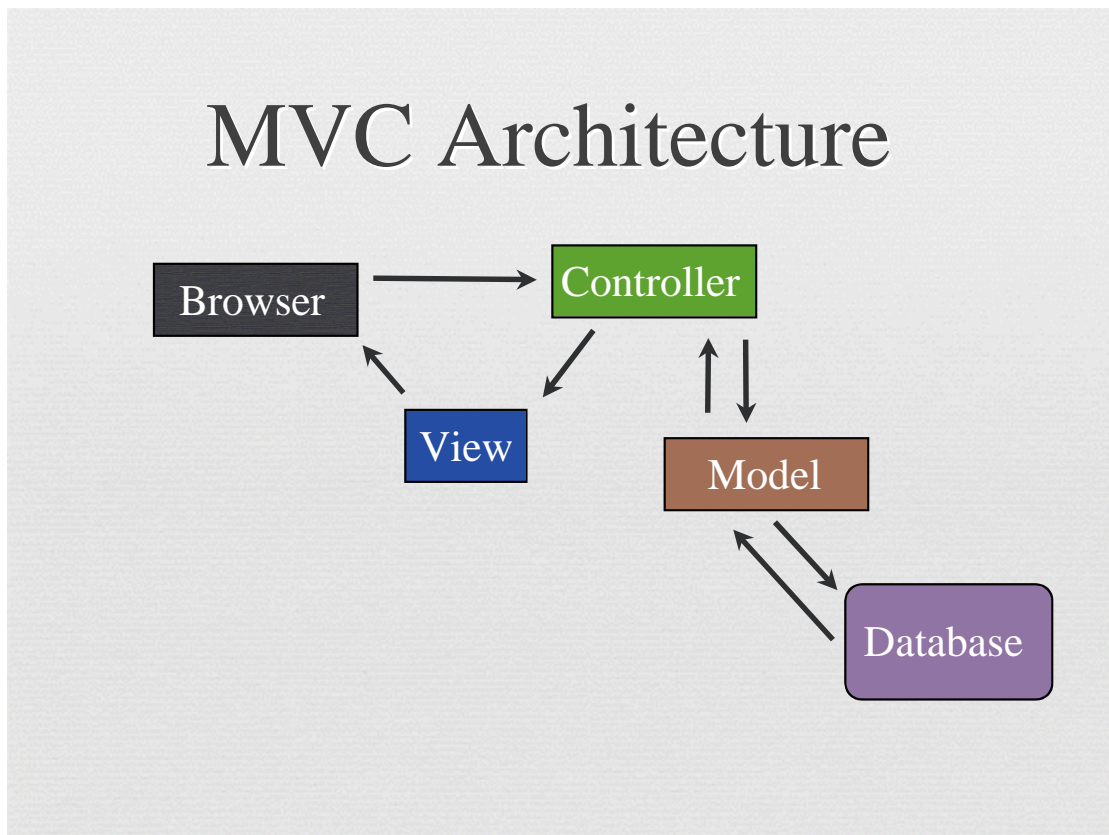


Figure 2.1. MVC Architecture of Ruby on Rails Framework

The MVC paradigm, also, is used by .NET, WebObjects, Struts, JavaServer Faces and Sun Microsystems' JRuby. A model enforces all of the business rules; a view generates the user interface; and a controller receives events from the user, interacts with the model logic and displays the view to the user.

Major companies that use Ruby on Rails are Amazon.com, BBC, Cisco, Google, NASA, New York Times, Oracle, Siemens, Sun Microsystems and Yahoo! (RoR Companies, 2009) Sun Microsystems has based much of its future upon RoR in the form of JRuby that is a compiled version of RoR that interoperates with Java platform applications. Regarding Ruby and JRuby, Sun states, "it combines the best features of many compiled and interpreted languages, such as easy development of large programs, rapid prototyping, almost-real-time development, and compact code. Ruby is a reflective, dynamic, and interpreted object-oriented scripting language, and JRuby is a Java programming language implementation of the Ruby language syntax, core libraries, and standard libraries." (Sun JRuby, 2009)

### 3. VIRTUALIZED RUBY ON RAILS (VROR)

#### 3.1 Operating System Virtualization

Operating system virtualization is where the operating system kernel allows isolated, contained, user environments (called containers) that limit the impact of one container upon another. In this instance the host operating system was Windows XP and the container consisted of either Microsoft (MS) Virtual PC (Microsoft Virtual PC, 2009) or VMware Server (VMware Server, 2009) installed under XP as its own virtual partition (Virtualization, 2009). The container is basically an isolated software duplicate of a real computer – operating system and all of its applications. The software running inside of a Virtual Machine (VM) cannot break out of its virtual world, or container. A container is a VM and its image may be saved (Virtual Machine, 2009). A VM image size, in the present examples, is less than 6 Gbytes. Hence, the need for the Virtual Lab portable hard drive to have a capacity in excess of 10 Gbytes. Research at NU used both MS Virtual PC and VMware Server for creating Virtual Machines. Ruby on Rails (VRoR) in the form of Instant Rails (Instant Rails, 2009) was installed on a VM and is referred to as Virtualized RoR or VRoR.

#### 3.2 Microsoft Virtual PC

MS Virtual PC (Microsoft Virtual PC, 2009) was used for classroom instruction and the majority of student Virtual Lab (Refer to Section 1.3.1) implementations since the NU classroom standard workstation environment is Windows XP. The VRoR installation works well for students at all levels of IT expertise.

#### 3.3 VMware Server

VMware Server (VMware Server, 2009) was used for performance evaluation and the general system architecture for the robust WebPortal application created in advanced ITM courses that involved multiple servers and is discussed in greater detail in Section 8, WebPortal Architecture.

### 3.4 Incompatibility of Virtual Machines

VM machines created on operating system virtualization software supplied by different vendors, in this case Microsoft and VMware, are not interoperable or interchangeable. Standards organizations are currently specifying operating system virtualization interoperability. VMware, however, does supply conversion software for MS Virtual PC to VMware VMs (Virtual Machine Converter, 2009).

## 4 AGILE PROBLEM DRIVEN TEACHING USING VRoR

Agile Problem Driven Teaching (APDT) was addressed by Dey (Dey et.al., 2009). APDT, as used in ITM similarly to Problem Based Learning (PBL), focuses on real-world problems. “Agility” components are introduced to more closely simulate the real-world workplace that students encounter. These agile components introduced are a) including multi-faceted problems that require multiple teams, b) adjusting the defined problem to available skills, and c) allowing team-members to discover alternate solutions and “work-arounds” while discovering the solution to a problem. ITM frequently requires redefining the problem in order to achieve a workable solution. Employing APDT methods in instruction better prepares students for the workplace.

Where PBL is based on a defined problem with usually one solution, APDT is based on the premise that agility, and creativity are required to redefine the problem in order to achieve a successful solution. VRoR facilitates Agile Problem Driven Teaching because RoR is based upon agile concepts. Furthermore, virtualization allows the development team to try a multitude of options in the same timeframe as the traditionally structured development of a single solution. The following courses are instances in which APDT was progressively used in the BS ITM program at National University:

- ITM 320 Introductory IT Management
- ITM 440 Database Systems Concepts and Data Modeling
- ITM 470 Information Security Management
- ITM 475 Information Security Technologies

## 5 INTRODUCTORY IT MANAGEMENT (ITM 320)

In this introductory ITM course, the text was management, as opposed to technology, focused. The challenge was the absence of HOL or experiential learning. The students wanted to get their hands on Web components but there was no lab associated with ITM320; only a classroom workstation, and perhaps a laptop or desktop at home. *The “Problem” introduced as part of APDT was “How can I as a student actually make the Web work for me?”* Here the instructor had to help them “think outside of the box.” Was there technology that they could use that would help them? The agile component identified was the introduction of the Virtual Lab – a USB drive that could work both inside and outside of the classroom. MS Virtual PC was placed on the classroom workstation and the students created their first Virtual Machine (VM) and loaded Windows XP onto it. This VM-1 was then copied onto their individual Virtual Lab USB drive. The instructor gave the students another pre-configured VM-2 with RoR on it that was

likewise loaded onto their Virtual Lab. With VM-2 and MS Virtual PC on the classroom workstation the students could immediately start a Message Board web application and test it by bringing up a Browser window. They now had an operating Web Server and Web Database Server and could witness the role of each kind of server. Just reading about the servers in the text now became reality. The next in-class assignment was to actually download RoR Instant Rails (Instant Rails, 2009) and load it onto the VM-1 that they previously created. The proof of success was being able to compare the operation of the upgraded VM-1 (on which the student installed InstantRails) to VM-2, which was supplied by the instructor.

The real fun was taking the Virtual Lab home, installing MS Virtual PC on a desktop or laptop and using the Virtual Lab VMs without conflicting with any of the desktop/laptop registry settings. Virtualization now became a reality to each student as they witnessed the protection of the virtual container. *The Learning Outcome was learning how to bring up an active Web Server and MySQL Database Server, and witnessing first-hand how the Web functions.*

## 6 DATABASE SYSTEMS (ITM 440)

In this introductory Database course, (ITM 440) the text was focused on MS Access and dealt with a very complicated healthcare database. It did little to prepare the students for their Senior Capstone project where they would have to create their own application; and operational Relational Database, normalize it and make it work; and most likely, use a Web interface. *The “Problem” introduced as part of APDT was “How can I as a student work with not only Access but MySQL?”* Again, the Virtual Lab and VRoR to the rescue. VM-2, used previously, was now installed and operational in minutes. None of the usual loss of several class periods just trying to get a common operating base to begin the actual assignment – wasted time frequently due to a multitude of driver problems introduced by different hardware configurations. RoR, because of its framework and MVC structure, provides basic data-entry and editing of all data fields which facilitates establishing an immediate data test-bed for checking out the database tables. SQL queries could now be performed from command line, PHPMyAdmin or by inserting SQL code directly in Ruby to produce custom reports. Class time could now be spent on solving database problems. Issues of how to handle foreign keys and properly normalized databases could now be dealt with firsthand. RoR additionally provided complete backup and recovery processes that could be evaluated. Furthermore, not only Access was learned, but MySQL was introduced which would be much more helpful in Senior Capstone projects. *The Learning Outcomes were a) learning how to bring up Access and MySQL database servers, and b) witnessing first-hand how a complete Web application functions and depends upon a robust relational database.*

## 7 INFORMATION SECURITY (ITM 470/475)

The sequence of security courses, ITM 470 and ITM475, deal with the ten domains associated with Certified Information Systems Security Professional (CISSP) preparation (Harris, 2008) and are taken just prior to the Senior Capstone sequence. The IT triad of effectively managing People, Technology and Processes emphasizes the dynamic nature of the project development cycle. The ability to complete a specific assignment where the problem has one solution no longer is the rule. Clients change their minds on what they want, technology does not always work the way it should and processes are frequently ill-defined. The IT professional must learn

to adjust quickly and dynamically in order to meet specified deliverables and timeframes. This is the domain of Agile Project Development and illustrates the need to introduce Agile Problem Driven scenarios to students who are soon to be in the accelerated “Internet-time” workplace. *The RoR component of the “Problem” introduced as part of APDT was “How do I as an IT professional architect and implement a VRoR that a) works with both MySQL and MS SQL and b) allows the data to interface with Windows SharePoint Services (WSS) 3.0 on a secure WebPortal?* The students found that agility required the problem to be divided into two sub-projects to be undertaken by two teams.

Team A successfully implemented VRoR under VMware Server but had to adjust from previous experience because of two issues. First, they had implemented a functioning application that tracked performance statistics for adjunct instructors at NU on a VM machine that ran under MS Virtual PC. The problem required a VM machine that would run on VMware. This required the team to evaluate several options and make a decision – an agile maneuver. RoR code is interchangeable, but they elected to go with a MS Virtual PC to VMware VM machine converter (Virtual Machine Converter, 2009) This was a good exercise in agility and APDT. The second issue was interfacing the RoR application to MS SQL rather than MySQL. Again, another exercise in agility because the solution was not handed to them. The agile design of RoR, however, facilitated the insertion of another type of relational database.

Team B was tasked with facilitating the interface of MS SQL and MySQL with WSS 3.0. The reason for this was to allow the development agility of RoR to work with MS SQL databases since SharePoint (WSS) is based on MS SQL and is very restrictive on the Web logic that it permits. Microsoft designed WSS to perform specific functions but did not allow generalized access to its underlying MS SQL database engine. Members of Team B felt that they had no possible solution. Again, exercising agility they searched until they discovered MS SharePoint Designer (SharePoint Designer, 2008), an application that facilitates interfacing external database engines such as MS SQL, MySQL and Oracle to WSS 3.0. This also allowed the use of SQL scripts to extract selective data from the external databases. Team B met the deadline of providing its solution in time to integrate with Team A’s VRoR environment in meeting the project deliverables. Success, but not until after having spent many days, seemingly, without a solution to the problem and experiencing frustration with the instructor for giving them what was perceived as a problem with no valid solution. At the conclusion, one student declared to the instructor, “It is now obvious that you have been teaching us in an Agile manner!” *The Learning Outcomes were a) installing a VRoR under VMware with both MS SQL and MySQL database servers, b) interfacing SharePoint (WSS) with external MS SQL and MySQL databases driven by RoR agile applications, and c) dividing the project labor in order to leverage skills and meet deadlines.*

## 8. WEBPORTAL ARCHITECTURE (ITM 470/475)

The network topology of the WebPortal architecture produced by the security courses ITM470/475 is shown in Figure 8.1. The five real servers are in gray and the seven virtual servers (VMs under VMware) are in beige. The contribution of virtualization and agile RoR was described in Section 6. There were other APDT components that produced this end product, but



success resulted from agility in adjusting to a) the skills of the students, b) the availability of team members where work assignments out-of-state created conflicts, c) stable, functional hardware, and d) compromise by the client (instructor) when non-essential features could not be implemented.

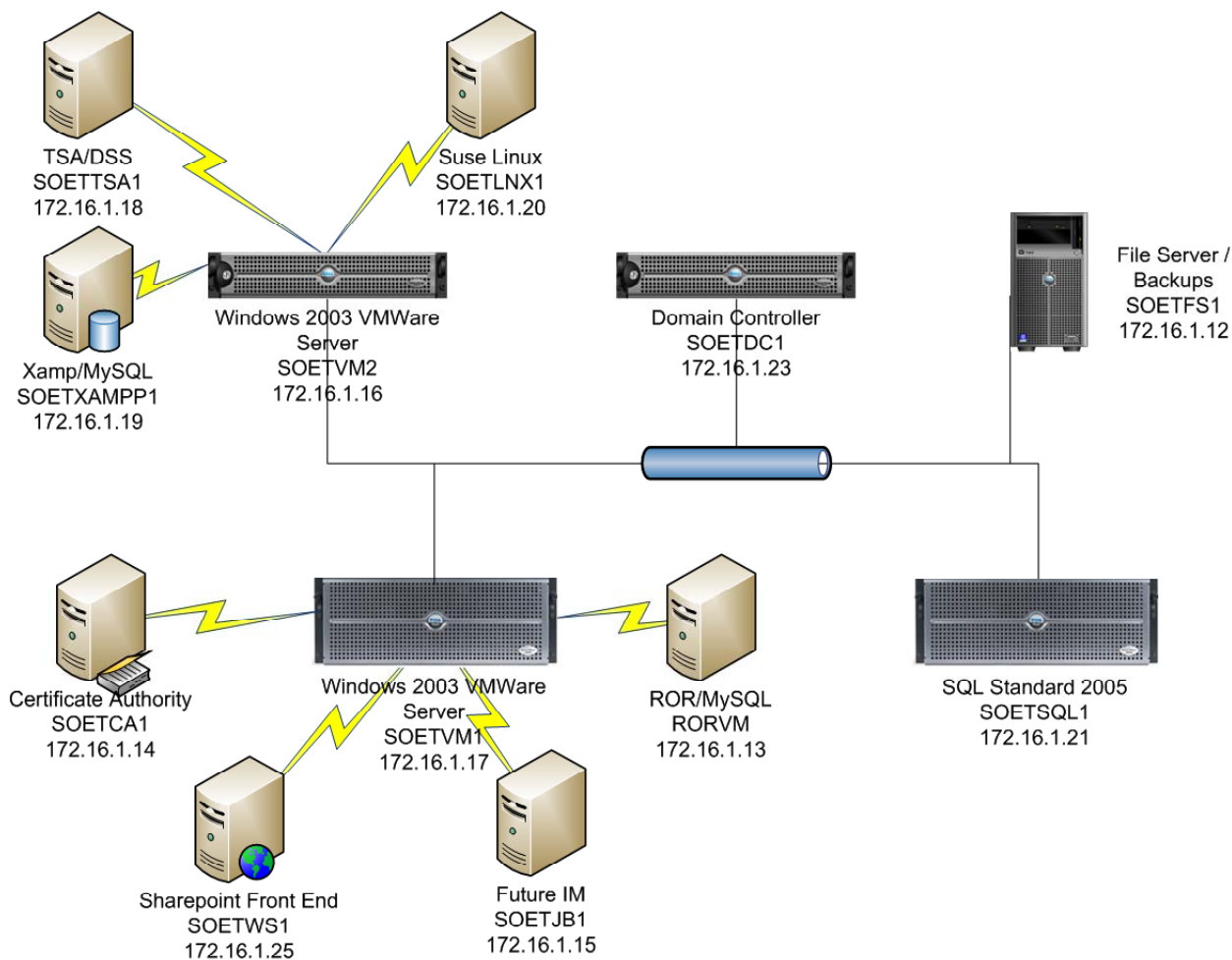


Figure 8.1. WebPortal Architecture

## 9. CONCLUSION AND FUTURE RESEARCH

The specific challenges introduced by the National University (NU) teaching model, as they apply to teaching Information Technology, are its accelerated pace, long instruction class periods, the lack of the traditional laboratory experience and the increasing demand for on-line instruction. Searching for tools to help meet these challenges, the author turned to a) use of a portable lab (also referred to as a Virtual Lab) in the form of a USB hard disk drive, b) operating system virtualization, c) Agile Project Development he first encountered in industry in 2002, and d) Agile Programming introduced by the Ruby on Rails (RoR) framework.

Web development with RoR is agile web development as it follows the Agile Programming, Agile Software Development (ASD) and Agile Project Management (APM) guidelines. The agile concepts specified in these guidelines have inspired the use of agile tools in the author's teaching. NU's School of Engineering and Technology has, as one of its primary objectives, the desire to prepare its students to be immediately productive in industry. Teaching students the four points of the Agile Manifesto for ASD places emphasis upon 1) individuals and communication, 2) working software, 3) customer collaboration, and 4) responding to change. Another NU objective is to prepare students for management by raising them from the level of "uninspired taskmaster" to that of "visionary leader" as emphasized by CC Pace (Ccpace, 2009). APM helps accomplish both objectives.

As described above, RoR introduces Agile Programming, projects demand Agile Project Management, and the introduction of real-world problems in class assignments leads to Agile Problem Driven Teaching. The examples given in Sections 5, 6, and 7 of specific problems illustrate the manner in which students had to exercise agility in producing a working solution within the "one-course-per-month" NU model. Experience over the past eighteen months for on-site teaching in the BS ITM program in which agility concepts have been introduced indicates that many students learn faster and better by hands-on-learning. The portable lab, virtualization, RoR and agile concepts in class problem solving appear to significantly address the specific challenges encountered at NU in the ITM program. Agile Problem Driven Teaching, at least in this limited context, appears to be most viable for the on-site classroom scenario. Only limited instances of usage of the portable lab in the on-line course scenario have been tested.

Future research will carefully deploy, monitor and assess both on-site and on-line course implementations of Agile Problem Driven Teaching. Training other instructors in the virtues of Agility and its proper usage has proved to be one of the greatest challenges to date. Hopefully, the success experienced in the NU BS ITM program, coupled with the rapid adoption by major corporations of Agility, will motivate others to seriously implement its guidelines. Students have been excited to be learning one of the most current approaches to web system development and project management. It is motivating to be current and "on the edge." Especially when one is keeping up with the likes of Amazon.com, Google, Yahoo! and NASA.

## REFERENCES

- Agile Manifesto. (2001). <http://agilemanifesto.org/>  
Retrieved 16 February 2009 06:45 UTC.
- Alleman. (2002). Alleman, Glen B., "Agile Project Management Methods for IT Projects," Niwot, CO 80503, Chapter X in *The Story of Managing Projects: A Global, Cross-Disciplinary Collection of Perspectives*, Dr. E. G. Carayannis and Dr. Y. H. Kwak, editors, Greenwood Press / Quorum Books, 2002;
- Alleman. (2009).  
<http://www.niwotridge.com/Resources/Columns&PublishedArticles.htm#Chapters>  
14 February 2009 12:32 UTC.
- Ccpace. (2009). Ccpace.com white paper, "Agile Project Management,"  
[www.ccpace.com/Resources/documents/AgileProjectManagement.pdf](http://www.ccpace.com/Resources/documents/AgileProjectManagement.pdf)  
Retrieved 14 February 2009 19:49 UTC.
- Crowley. (2003). E. Crowley, "Information System Security Curricula Development," *CITC4'03*, pp. 249-255, October 2003.
- Dey et.al. (2009). P.P. Dey, T.M. Gatton, M.N. Amin, M.F. Wyne, G.W. Romney, A. Frarahani, A. Datta, H. Badkoo behi, R.Belcher, O.Tigli and A.P. Cruz, "Agile Problem Driven Teaching in Engineering, Science and Technology," ASEE/PSW-2009 Conference, San Diego, CA March 18-20, 2009.
- Fowler. (2006). Fowler, Chad, "Rails Recipes," 2006, The Pragmatic Bookshelf, Dallas, Texas, ISBN: 0-9776166-0-6.
- Fulton. (2006). Fulton, Hal, "The Ruby Way," Second Edition 2006, Addison-Wesley, Boston, MA 02116, ISBN: 0-672-32884-4.
- Harris. (2008). Harris, Shon, "All-in-One CISSP – Exam Guide," Fourth Edition 2008, McGraw-Hill, New York, New York 10121 ISBN: 978-0-07-149787-9.
- Highsmith. (2004). Highsmith, Jim, "Agile Project Management: Creating Innovative Products," 2004 Addison-Wesley, Boston, MA 02116 ISBN-13: 9780321219770
- Holzner. (2007). Holzner, Steven, "Beginning Ruby on Rails," 2007, Wiley Publishing, Inc., Indianapolis, IN 46256, ISBN-13: 978-0-470-06915-8
- Instant Rails. (2009). <http://instantrails.rubyforge.org/wiki/wiki.pl>  
Retrieved 8 Mar 2009 23:42 UTC.
- Microsoft Virtual PC. (2009). <http://www.microsoft.com/virtualization/default>  
Retrieved 8 Mar 2009 23:18 UTC.
- Orsini. (2007). Orsini, Rob, "Rails Cookbook," 2007, O'Reilly, Sebastopol, CA 95472, ISBN-13: 978-0-596-52731-0.
- Raymond. (2007). Raymond, Scott, "Ajax on Rails," 2007, O'Reilly, Sebastopol, CA 95472, ISBN-13: 978-0-596-52744-0.
- RoR Companies. (2009).  
<http://blog.obiefernandez.com/content/2008/03/big-name-compan.html>  
Retrieved 19 Feb 2009 06:25 UTC.
- SharePoint Designer. (2008).  
<http://office.microsoft.com/en-us/sharepointdesigner/FX100487631033.aspx>  
Retrieved 19 Dec 2008 17:55 UTC.
- Sun JRuby. (2009). <http://java.sun.com/developer/technicalArticles/scripting/jruby/>  
Retrieved 9 Mar 2009 18:41 UTC.
- Thomas. (2005). Thomas, Dave, "Programming Ruby," Second Edition 2005, The Pragmatic Bookshelf, Dallas, Texas, ISBN 0-9745140-5-5.
- Thomas. (2007). Thomas, Dave, Hansson, David Heinemeier, "Agile Web Development with Rails," Second Edition 2007, The Pragmatic Bookshelf, Dallas, Texas, ISBN-13: 978-0-9776166-3-3.

- Virtual Machine. (2009). [http://www.techcessgroup.com/V\\_machine.php](http://www.techcessgroup.com/V_machine.php)  
Retrieved 7 March 2009 03:43 UTC.
- Virtual Machine Converter. (2009). <http://www.vmware.com/products/converter/>  
Retrieved 9 Mar 2009 07:29 UTC.
- Virtualization. (2009). <http://en.wikipedia.org/wiki/Virtualization>  
Retrieved 8 Mar 2009 23:22 UTC.
- VMware Server. (2009). <http://www.vmware.com>  
Retrieved 8 Mar 2009 23:20 UTC.
- Williams. (2007). Williams, Justin, "Rails Solutions – Ruby on Rails Made Easy," 2007, Apress, Berkeley, CA 94710, ISBN-13: 978-1-59059-752-1.

**Biography:**

Gordon W. Romney, Ph.D. is a Professor in the Department of Computer Science and Information Systems, School of Engineering and Technology, at National University. He is Director and Senior Research Scientist of the SOET Cyber Security and Information Assurance Laboratory.

# Implementation of Efficient Two-Factor Authentication for University Computer Systems

Gordon W. Romney and Paul D. Juneau

National University, 3678 Aero Court, San Diego, CA 92123, U.S.A.

## ABSTRACT

The implementation of an efficient two-factor authentication process for users to gain access to university computer systems was developed by students in an undergraduate Information Technology (IT) security course. Many universities use the less-reliable, single-factor authentication of a process ambiguously referred to as NetID for faculty, staff, students and alumni. Although referred to as NetID, the process and technology may vary widely across universities. Witnessing the inadequacy of NetID to provide a secure university infrastructure, students were challenged to develop an improved, more secure authentication protocol. They based their solution upon an SSL secure web-site that also required a client browser certificate. This process combined the standard ID-Password of the web site (first factor) with a less-known feature of SSL, a client browser certificate (second factor) unique for each user. To make it not only secure but efficient the students cleverly stored the second factor component in a secure, portable container on a USB flash drive that makes it usable on computers in class and out of class.

Key Words: authentication, multi-factor authentication, SSL, digital certificate, browser certificate, portable certificate, and Agile Problem Driven Teaching

## 1. INTRODUCTION

### 1.1 User Authentication

Authentication, in an IT security context, has to do with authenticating the identity of a computer user. In order for authentication to be possible, a user must first be registered, or enrolled, as a valid subscriber on a specific computer system. This process normally produces a couplet of a “username” plus a “password/number.” Examples are registering for a) social security number, b) library, or c) university or employment access privilege. Enrollment processes vary in quality and thoroughness and only security policy as specified by the controlling organization can determine true identity verification for a specific user. It is not the purpose of this paper to address identity validation or prove “I am who I say I am.”

### 1.2 Authentication Factors

Features of authentication are referred to as “factors”. Authentication normally consists of linking a “username” with one or more factors. The security authentication factors frequently referenced are (Smith, 2002):

Things you know ... such as a PIN number or password

Things you have ... such as a smartcard or digital certificate

Things you are ... such as a biometric personal attribute: fingerprint, or iris image

One-factor authentication employs one of the factors, and, most frequently, is something that you know, such as a password. Two-factor authentication is a combination of two of the factors, such as a password and a digital certificate. As the number of factors employed increases, so does the security confidence increase. Hence, three-factor authentication is considered the most robust form of authentication. In a like manner, the implementation complexity and cost associated with the authentication increases as the number of factors employed increases.

### 1.3 The Need for More Than One-Factor Authentication

The Information Age challenge, to every person (persona), is that most enrollment processes, irrespective of whether they are online or in ink, a) are assumed to be adequate for authentication purposes because they assign some number or password (secret or not), b) are not secure because they are a default ONE-factor authentication, c) do not validate the identity of the persona, d) are easily compromised or hacked because they are the weakest, and e) facilitate identity theft

Normal username + password authentication can be compromised for a multitude of reasons; and, because it is the easiest and cheapest to implement, continues to be used by the majority of university and industry web-based Internet systems. This couplet is something that the persona knows and, consequently, can be hacked by brute force or by “man-in-the-middle” attacks. The username structure in practice is a combination of last name and first name and sometimes numeric additions. Usernames are frequently publicly known or can be determined through social engineering analysis where an attacker obtains information by non-technical means. Universities, also, are notorious for providing insecure wireless environments subject to hacking (Romney, 2008). Given multiple tries, hackers have readily available software that will allow them to crack most passwords because humans, for recall purposes, like to use words that occur in human language dictionaries. “When an attacker gets hold of a legitimate username and password, he won’t need a lot of skills to ‘hack’ into the system.” (Password Hacking, 2009)

### 1.4 University Computer System Authentication

One-factor authentication, consisting of a username + password couplet, called NetID and employed by unique software in virtually every instance, is used by the majority of universities in the U.S. (BYU, 2009; Cal State U East Bay, 2008; Cornell U, 2009; Duke U, 2008; Harvard U, 2009; Princeton U, 2009; Purdue U, 2009; U Mass Amherst, 2008; U Washington, 2008; U Wisconsin, 2008; and Yale U, 2009). NetID is simply a convenient acronym but does not designate a common software origin. The universities’ security policies are as diverse as the versions of software. In most cases the usernames are assigned for the life of the recipient, on campus and later as an alum off campus. Most are vulnerable to personas with dual roles, such as a student and a staff member, being compromised (Romney, 2008). UMass Amherst is somewhat unique and allows different passwords for different roles (U Mass Amherst, 2008). Most of these systems are LDAP-based and the directory information is not private nor anonymous.

The MIT Kerberos Consortium manages a Kerberos authenticated platform that is made available to universities that is considerably more robust. It is still one-factor authentication but relies on a trusted third party model of the university Kerberos system maintaining a database of

clients and their secret keys which the system generates and provides to the users (Schneier, 1996; Smith, 2002). For a persona, the secret key is an encrypted password. Kerberos generates a ticket that the persona presents along with an authenticator to a server. An eavesdropper cannot replay the ticket and authenticator at a later time. The overall system, however, does require careful administration. This platform permits universal "single sign-on" within and between federated enterprises and peer-to-peer communities (MIT Kerberos, 2009); (Duke U Kerberos, 2009; MIT U Kerberos, 2009; U Washington Kerberos, 2009).

Other unique Kerberos-based systems are employed at MIT, Stanford and Carnegie Mellon (Stanford U, 2009 and Carnegie Mellon U, 2009). The Stanford system does allow a persona to control what is displayed in the online directory, but the stored information is not private nor anonymous.

From this brief survey, it is apparent that the majority of universities find a NetID, one-factor user authentication satisfactory. The author has found the one-factor solution to be highly vulnerable in most university settings, particularly due to eavesdropping and man-in-the-middle attacks. The move to Kerberos by some of the more technologically-advanced universities such as Carnegie Mellon, MIT and Stanford demonstrates the sensitivity to vulnerabilities associated with simple NetID one-factor authentication and their attempt to mitigate such vulnerabilities.

One-factor authentication involving Kerberos uses symmetric key cryptography with the advantage that its trusted third party maintains management of all secret keys. Key management over an extended period and key revocation are basically eliminated. The cost is more than traditional NetID but less than two-factor authentication alternatives for over 20,000 users. Two-factor authentication involving something you know and have such as digital certificates generally has not been used in university environments, the author suggests based on his experience of having done so in healthcare, due to the complexities of implementing asymmetric Public Key Infrastructure (PKI). Two-factor authentication involving something you know and something you are is even more cumbersome because of the biometric readers required at many locations (Stevenson & Romney, 2008). Three-factor authentication is used in data centers, high risk financial operations, certification authorities and special research facilities in industry and university research. In these instances, PKI and biometrics are frequently the selected technologies with a characteristically much higher operational overhead.

### 1.5 Agile Problem Driven Teaching Utilized

In keeping with the Agile Problem Driven Teaching (APDT) pedagogy employed in the National University (NU) School of Engineering and Technology (SOET) described by Dey (Dey et.al., 2009), and, specifically, the BS IT Management (ITM) program (Romney, 2009), the search for improved authentication for smaller enterprises and select university settings was structured into an APDT problem and assigned to undergraduate students in the ITM470/475 IT Security sequence of courses. APDT, as used in ITM similarly to Problem Based Learning, focuses on real-world problems. "Agility" components are introduced to more closely simulate the real-world workplace that students encounter (Agile Manifesto, 2001; Alleman, 2002; Alleman, 2009). These agile components introduced allow students to be creative in discovering alternate solutions and "work-arounds" to a problem. Employing APDT methods in instruction better

prepares students for the workplace. *The defined Problem was to design and implement a useable two-factor authentication process for use by small enterprises and on the SOET WebPortal by less than one thousand faculty, staff, and students.*

### 1.6 Secure Sockets Layer and Transport Layer Security

Each of us, when we make a purchase, makes use of what was originally called the Secure Sockets Layer (SSL) protocol that was developed and introduced by Netscape (Lee, 2007). The Internet Engineering Task Force (IETF) later renamed and enhanced the standard Transport Layer Security (TLS), to emphasize that it works at the transport layer of the OSI model. For SSL v1 and v2, authentication was a one-way process handled by the server. SSL/TLS uses both symmetric and asymmetric cryptography (Smith, 2002; Panko, 2003) in order to secure the transmissions between a server (for example at Amazon.com) and a user's client browser on their laptop. For the asymmetric component, the server uses a server SSL certificate normally obtained from a trusted certification authority like Verisign. Usually the acceptance of the SSL certificate by the client browser occurs without any intervention by the user, and a padlock symbol, as shown in Figure 1.6.1 appears on the browser to indicate that the transmission between client and server is now securely encrypted.

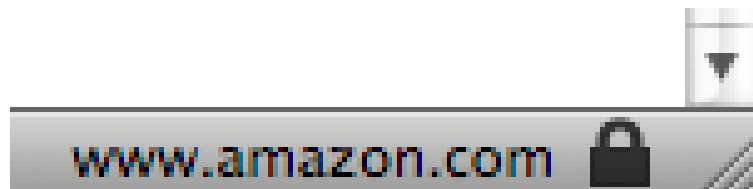


Figure 1.6.1 SSL Padlock Symbol on Browser

When the browser is closed, or the session terminates due to non-use, the secure communication closes.

### 1.7 SSL Client Authentication

In SSL v3/TLS, the less well known, and frequently unused communal authentication of both client and server is applicable. Not only is there the SSL Server certificate as previously discussed, but a client browser certificate is used as well. Thus, those who desire to access the server must be pre-enrolled and be possessors of a client browser digital certificate. The certificate exchange is done via x.509 certificates, and public key cryptography is used to start the connection. Two to four seconds is required to establish the secure connection. Once authentication is made, the channel is secured with symmetric key cryptography methods and hashes, typically RC4 or 3DES for symmetric key and MD5 or SHA-1 for the hash functions (IBM, 2007).

### 1.8 Security Students Architected a Two-factor Authentication Solution

ITM students accepted the APDT problem to design and implement a useable two-factor authentication process using the SOET WebPortal architecture shown in Figure 1.8.1.



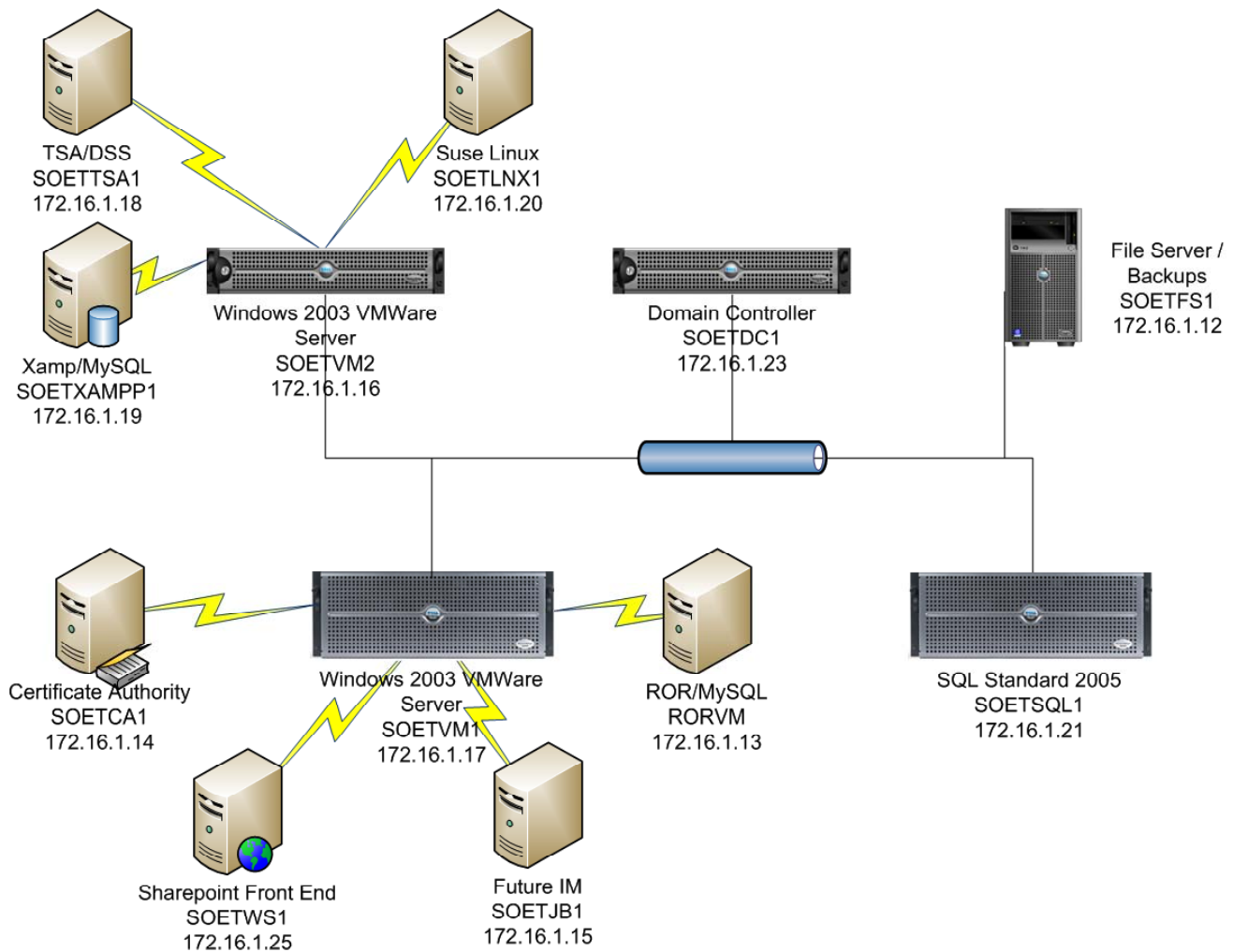


Figure 1.8.1. SOET WebPortal

The WebPortal environment was initially architected by the student co-author, Juneau, and implemented by his team of students using Microsoft (MS) .NET technology with Windows 2003 Server. Other preliminary projects were the installation of MS Internet Information Services (IIS) 6.0, with Active Directory and Domain Controller, a Certificate Authority and Windows SharePoint Services (WSS) 3.0. The security component that is the purpose of this paper, and the Problem addressed in Section 1.5, above, was to provide a useable two-factor authentication process for users who want to access the WebPortal, and, initially, the SharePoint Front End server SOETWS1 that is to the left on the bottom row in Figure 1.8.1.

Juneau's team decided to employ Secure Sockets Layer (SSL) and require a client to present the following two authentication factors in order to gain access to the WebPortal: 1) the first authentication factor (something you know) of a username and password couplet, and then 2) the

second factor (something you have) of an SSL client browser certificate and it requires its own additional, (something you know), of a secure pass phrase. The Plan was to complete the following steps:

1. Designate and authorize two administrative roles to be played following Security Best Practices:
  - a. a System Administrator (SysAdmin) with administrative rights to all necessary processes.
  - b. a Certification Authority Administrator (CAAdmin) with administrative rights to all certificate management processes.
2. Have the SysAdmin enroll the clients (students and instructors) with username and password couplets into Active Directory. Have the clients change their passwords.
3. Have the SysAdmin apply for a Secure Sockets Layer (SSL) server certificate via web access for the IIS server via the Certificate Authority SOETCA1.
4. Have the CAAdmin issue the pending SSL server certificate via the Certificate Authority.
5. Have the SysAdmin install SSL on IIS.
6. Have all clients apply for personal SSL client browser certificates via web access to the Certificate Authority; an individually secure pass phrase must be specified.
7. Have the CAAdmin issue the pending personal SSL client browser certificates via the Certificate Authority.
8. Have the clients download their issued certificate into the browser they have selected using the previously specified secure pass phrase.

The clients were all located in a SOET classroom and would use the standard classroom Windows workstations for the exercise. The final objective was to see a client a) bring up a browser, b) specify the URL for the SOET WebPortal and be prompted to specify her username and password, c) be prompted to present the client browser certificate that had been stored in the workstation browser and specify the secure passphrase, and then d) be allowed access to the SOET SharePoint Home Web page.

## 2. THE TEAM EXECUTION OF THE PLAN

One key objective of the APDT model is to not only use Agile methods in teaching, but to employ them in programming and project management. Over the extent of the course, the student teams were being trained in the methodology of Agile Project Management. Raising a project manager from the level of “uninspired taskmaster” to that of “visionary leader” can effectively be achieved by employing Agile Project Management (Cppace, 2009). Challenges were encountered in the execution of the Plan defined in Section 1.8, and adjustments to strategy and “workarounds” had to be made. Examples of these ‘glitches’ or problems so typical of IT, identified and solved by the team, are those described in Sections 2.1 through 2.3. Sections 2.4 and 2.5 deal with issues caused by the client user, the instructor, modifying the deliverables.

### 2.1 Inability of the Web Server to Join the SOET Domain

The problem encountered was the inability of the CA server to communicate with the Web server. This was caused by the Routing and Remote Access (RRA) network service in MS Windows Server which was enabled and included activating the Network Address Translation (NAT) feature which masked the IP of the CA server making it inoperative. Simply disabling the RRA network service created no additional problems and allowed the CA to function in order to issue digital certificates.

### 2.2 Inability to Create and Install the Certificate Authority Web Server

The problem encountered was the inability to create the Certificate Authority Web Server. It was discovered that this was a loading sequence issue. When MS Server 2003 CA was installed first and IIS second, the CA did not work. Reversing the order and installing IIS first and then installing MS Server 2003 CA allowed the creation of a CA web site that was crucial in order to apply, issue and download digital certificates.

### 2.3 Inability to Access the Default Web Page Under IIS

The problem encountered was when attempting to access the web server, the default web page of the ISS server was reporting to users that the server required them to use a secure connection. When we added “s” to the “http” in the address bar, it would redirect them to “http://soet-web/index.aspx”. Somehow, the server process left the “s” out of the default web page. Through research and some handy JavaScript code, we were able to create a custom 404-3 error that would redirect requests to the correct site using SSL.

### 2.4 User Client’s Requirements Change

IT emphasizes synergistic solutions between technology, people and processes to successfully resolve enterprise computer problems. In the ITM program, students learn that people, namely the client, drive the development process. IT professionals, with their knowledge, skills and set of technology tools attempt to meet the requirements specified by the client. In almost every development instance, the client’s perception of the desired product evolves. That was the case in this particular instance as the instructor, serving as client user, changed a requirement that the browser used in the authentication process needed to be not only MS Internet Explorer (IE) but also Firefox.

The team, in an attempt to meet the client user’s changing requirements tried, unsuccessfully, to replace the working IE browser with a Firefox browser. It found that Windows Server 2003 CA would not allow Netscape version 6.2.2 and later browsers to perform enrollment through the Web enrollment pages. The following command entered at the command prompt resolved the problem: `certutil -setreg ca\CRLFlags +CRLF_ALLOW_REQUEST_ATTRIBUTE_SUBJECT`  
The team’s perseverance prevailed with success.

## 2.5 Team Discovers an Enhancement that the User Client Couldn't Do Without

Over the duration of the execution of the Plan, the team continuously discussed the proposed solution to the problem specified in Section 1.5 with the client user and discovered that both the client user and the team were not satisfied with step 9 in the Plan specified in Section 1.8. This step called for the clients to install the personal browser certificate in the browser of the classroom workstation. Such an installation constrained the authentication process to a static workstation. Portability of the certificate is what was needed. The team searched and Juneau discovered an Open Source secure, portable container provided by TrueCrypt that would allow the encrypted storage of browser certificates (TrueCrypt, 2009). Furthermore, it would allow the installation of portable applications including Firefox (PortableApps, 2009).

### 3.0 TRUECRYPT PORTABLE VIRTUAL ENCRYPTED CONTAINER

The objective is to have a browser digital certificate securely stored on a portable USB flash drive that one can take to the classroom, home or any Internet café and use to gain access to the SOET WebPortal using two-factor authentication.

TrueCrypt.com provides an Open Source portable, virtual encrypted drive capability (TrueCrypt, 2009). A USB flash drive with a minimum of 128 MBytes is required as the physical storage device. TrueCrypt is executable software for either Windows or OS X that creates a container, or file, on which a volume is defined. A container is just like any normal file as it can be moved, copied or deleted and has a filename. Military grade encryption, AES-256, is used to encrypt/decrypt all files moved to/from the container under password control. All of this is done automatically by the TrueCrypt software.

#### 3.1 Portable Firefox and Browser Certificate Storage

For this example of authentication, a USB flash drive was installed on a workstation. A TrueCrypt volume was created, encryption algorithm selected, and password specified. For more general usage, Firefox was designated the browser of choice. Portable Firefox was downloaded and stored encrypted in the container. A client browser certificate was requested as step 6 in the Plan of Section 1.8. Step 7 issues the certificate, and the client downloaded the issued certificate as step 8. This certificate was imported to the Firefox browser and stored encrypted. The TrueCrypt volume was dismounted, and the USB flash drive was stopped and unplugged.

#### 3.2 To use the TrueCrypt Container

The portable certificate vault may be taken to any workstation, plugged in and used to bring up Firefox. If the SOET SSL URL is specified, the browser certificate will be activated and both factors of authentication implemented to allow access to SharePoint on the WebPortal via a secure SSL transmission. Otherwise, Firefox functions as a normal browser which it is. Figure 3.2.1 illustrates the Client Browser Certificate being presented for authentication to go to the ASEE PSW09 Meeting web page. The Calendar page is revealed under the certificate.

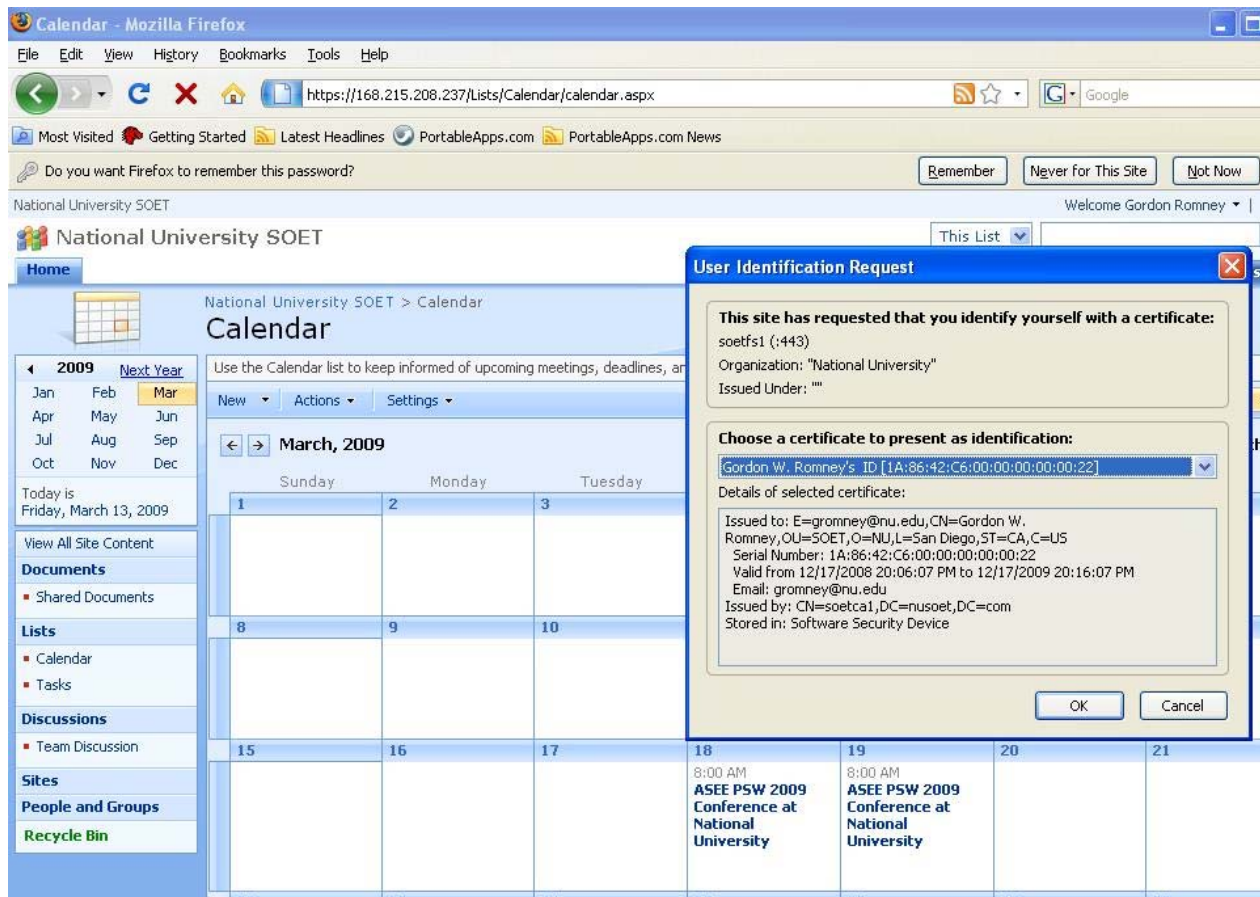


Figure 3.2.1. Client Browser Certificate and SOET SharePoint Calendar

The certificate vault is fully encrypted by military grade cryptography. The certificate issued to the user is only accessible out of the vault under password control as it is called up by the browser.

#### 4.0 CONCLUSION AND FUTURE RESEARCH

*The defined Problem was to design and implement a useable two-factor authentication process for use by small enterprises and on the SOET WebPortal by less than one thousand faculty, staff, and students.* The Learning Objectives of developing the solution to this problem in an agile manner in keeping with Agile Project Management were met most satisfactorily by the student team as workarounds to “glitches” were effectively implemented. Additionally, the team demonstrated a mature approach to dealing with client user modifications to the original project requirements which is one of the fundamental tenants of the Agile Manifesto (Agile Manifesto, 2001). Most impressively, the team demonstrated a superior ability to be constantly communicating with the client user which, in turn, led to the mutual accord to pursue the TrueCrypt encrypted portable container solution. The absence of such communication would not have produced a most novel and critically important solution. This effort produced a satisfactory two-factor authentication solution applicable to not only the SOET NU university environment, but one that is viable for many small to medium sized business enterprises that want to augment the quality of their security beyond standard username + password solutions.

The constraint of a maximum of “one thousand” personas is based on past experience in managing personal certificates. The security policies can be established such that certificate revocations are not an issue. Most universities, after all, keep user NetIDs for life. Storage, likewise is not a major constraint since disk storage costs continue to decrease. The greatest concern is in developing a streamlined process for enrollment and certificate downloading into TrueCrypt containers. Research will need to be done to determine the limiting factor associated with this portable certificate vault solution.

Another issue of concern to NU is that a substantial number of NU students are associated with the Navy, Marines and Department of Defense contractors. The recent ban in 2008 on the use of USB jump drives presents a slight impediment. The TrueCrypt portable container, however, can be stored on mini-CDs.

Future research in the area of Kerberos and pursuit of the MIT Kerberos Consortium have merit.

A most intriguing authentication methodology that uses the cell phone as a second factor of authentication is marketed by PhoneFactor.com (PhoneFactor, 2009). This we anticipate to pursue in future research.

#### REFERENCES

- Agile Manifesto. (2001). <http://agilemanifesto.org/>  
Retrieved 16 February 2009 06:45 UTC.
- Alleman. (2002). G.B. Alleman, “Agile Project Management Methods for IT Projects,” Niwot, CO 80503, Chapter X in *The Story of Managing Projects: A Global, Cross-Disciplinary Collection of Perspectives*, E. G. Carayannis and Y. H. Kwak, editors, Greenwood Press / Quorum Books, 2002.
- Alleman. (2009).  
<http://www.niwotridge.com/Resources/Columns&PublishedArticles.htm#Chapters>  
Retrieved 14 February 2009 12:32 UTC.
- BYU, (2009). <https://y.byu.edu/ae/prod/person/cgi/createNetId.cgi>  
Retrieved 15 February 2009 12:24 UTC.
- Cal State U East Bay. (2008).  
<http://www.csueastbay.edu/ics/helpdesk/HDNetIDFAQS.html>  
Retrieved 29 November 2008 13:33 UTC.
- Carnegie Mellon U. (2009). <http://www.net.cmu.edu/docs/arch/netbar.html>  
Retrieved February 20 2009 14:34 UTC.
- Ccpace. (2009). Ccpace.com white paper, “Agile Project Management,”  
[www.ccpace.com/Resources/documents/AgileProjectManagement.pdf](http://www.ccpace.com/Resources/documents/AgileProjectManagement.pdf)  
Retrieved 14 February 2009 19:49 UTC.
- Cornell U, (2009). <https://netid.cornell.edu/> Retrieved 15 February 2009 12:14 UTC.
- Crowley. (2003). E. Crowley, “Information System Security Curricula Development,” *CITC4’03*, pp. 249-255, October 2003.
- Dey et.al. (2009). P.P. Dey, T.M. Gattton, M.N. Amin, M.F. Wyne, G.W. Romney, A. Frarahani, A. Datta, H. Badkoo behi, R.Belcher, O.Tigli and A.P. Cruz, “Agile Problem Driven Teaching in Engineering, Science and Technology,” ASEE/PSW-2009 Conference, San Diego, CA March 18-20, 2009.

- Duke U. (2008).  
<http://www.oit.duke.edu/netid-security/netid/>  
 Retrieved 29 November 2008 13:27 UTC.
- Duke U Kerberos, (2009). [www.security.duke.edu/netid-authentication.html](http://www.security.duke.edu/netid-authentication.html)  
 Retrieved 3 March 2009 16:34 UTC.
- Harris. (2008). S. Harris, “All-in-One CISSP – Exam Guide,” Fourth Edition 2008, McGraw-Hill, New York, New York 10121 ISBN: 978-0-07-149787-9.
- Harvard U, (2009). [www.ssrn.com/SiteLic\\_orgSubscribers.cfm?netid=810024](http://www.ssrn.com/SiteLic_orgSubscribers.cfm?netid=810024)  
 Retrieved 15 February 2009 12:09UTC.
- IBM. (2007). IBM, “Using the Secure Sockets Layer protocol for secure communications,”  
<http://publib.boulder.ibm.com/infocenter/wasinfo/v1r0/index.jsp?topic=/com.ibm.websphere.ihs.2047.doc/9atssl.htm>  
 Retrieved 16 August 2008 04:10 UTC.
- Lee. (2007). H.K. Lee, “Cryptographic Strength of SSL/TLS Servers”,  
<http://www.imconf.net/imc-2007/papers/imc130.pdf>  
 Retrieved 20 March 2008 04:23 UTC.
- MIT Kerberos. (2009). <http://www.kerberos.org/>  
 Retrieved 6 March 2009 13:25 UTC.
- MIT U Kerberos. (2009). <http://web.mit.edu/Kerberos/dist/>  
 Retrieved 6 March 2009 13:17 UTC.
- Password Hacking. (2009). <http://www.techexams.net/technotes/securityplus/passwords.shtml>  
 Retrieved 4 March 2009 15:23 UTC
- Panko. (2003). R.R. Panko, “Corporate Computer and Network Security,” 2003, Prentice Hall, Upper Saddle River, NJ 07458, ISBN: 0-13-038471-2.
- Phone Factor. (2009).  
<http://www.phonefactor.com/how-it-works/white-paper/download/>  
 Retrieved 9 March 2009 17:52 UTC.
- PortableApps. (2009). <http://www.portableapps.com>  
 Retrieved 19 November 2009 16:43 UTC.
- Princeton U. (2009). [http://www.princeton.edu/tigers12/infotech/your\\_princeton\\_netid/](http://www.princeton.edu/tigers12/infotech/your_princeton_netid/)  
 Retrieved 7 February 2009 22:02 UTC
- Purdue U. (2009).  
[www.itap.purdue.edu/security/files/documents/RASCCIAv13.pdf](http://www.itap.purdue.edu/security/files/documents/RASCCIAv13.pdf)  
 Retrieved March 4 2009 18:28 UTC
- Romney. (2008). G.W. Romney, “There Exists a Critical Need for Role-based IDs in a University IT Infrastructure in Order to Meet Security Best Practices,” International Computer Science and Technology Conference, San Diego, April 2008.
- Romney. (2009). G.W. Romney, “The Integration of Ruby on Rails As An Agile Teaching Tool in IT Curricula,” ASEE/PSW-2009 Conference, San Diego, CA March 18-20, 2009.
- Schneier. (1996). B. Schneier, “Applied Cryptography,” 1996, John Wiley & Sons, Hoboken, NJ 07030-5774, ISBN: 0-471-12845-7.
- Smith. (2002). R.E. Smith, “Authentication – From Passwords to Public Keys,” 2002, Addison-Wesley, Upper Saddle River, NJ 07458, ISBN: 0-201-61599-1.
- Stanford U. (2009). <https://sunetid.stanford.edu/>  
 Retrieved 7 March 2009 16:12 UTC.
- Stevenson & Romney. (2008).B.R. Stevenson and G.W. Romney, “Analysis of Near-infrared Phase Effect on Biometric Iris Data Demonstrates Viability of An Iris-scan Biometric Device for Identity Authentication in Public Venues,” International Computer Science and Technology Conference, San Diego, April 2008.

- TrueCrypt. (2009). <http://www.truecrypt.com>  
Retrieved 8 March 2009 15:46 UTC
- UC Irvine. (2009). <http://www.ucop.edu/irc/itlc/ucfedauth/IMCriteria/UCI/IM-Criteria-UCI.html>  
Retrieved 7 March 2009 15:24 UTC.
- U Mass Amherst. (2008). [http://www.oit.umass.edu/spire/logon/preferred\\_role.html](http://www.oit.umass.edu/spire/logon/preferred_role.html)  
Retrieved 29 November 2008 14:24 UTC.
- U Washington. (2008). <http://www.washington.edu/computing/uwnetid/>  
Retrieved 29 November 2008 11:38 UTC.
- U Washington Kerberos. (2009).  
[www.washington.edu/computing/infra/shibboleth/uwash-incommon-pops.doc](http://www.washington.edu/computing/infra/shibboleth/uwash-incommon-pops.doc)  
Retrieved 4 March 2 2009 18:54 UTC.
- U Wisconsin. (2008). <http://helpdesk.wisc.edu/page.php?id=4966>  
Retrieved 29 November 2008 16:46 UTC.
- Yale U. (2009). [www.yale.edu/its/accounts/netid.html](http://www.yale.edu/its/accounts/netid.html) Retrieved 3 Mar 2009 23:12 UTC.

#### BIOGRAPHY

Gordon W. Romney, Ph.D. is a Professor in the Department of Computer Science and Information Systems, School of Engineering and Technology, at National University. He is Director and Senior Research Scientist of the SOET Cyber Security and Information Assurance Laboratory.