

# **ASEE MidAtlantic Section Fall Conference**

**October 28-29, 2011**

# **Proceedings**

**Hosted by  
College of Engineering  
Temple University,  
Philadelphia, PA 19122**

**Total Number of Presentations: 87  
(including 5 students presentation)**

**Total Number of Attendees: 105**

## Table of Contents

	<b>Page</b>
<b>Program see the attached the excel sheet</b>	
<b>Conference Committee</b>	<b>3</b>
<b>Key note addresses- speakers</b>	<b>4</b>
<b>Section 1</b>	<b>17</b>
<b>Section 2</b>	<b>125</b>
<b>Section 3</b>	<b>250</b>
<b>Section 4</b>	<b>372</b>
<b>Section 5</b>	<b>489</b>
<b>Section 6</b>	<b>601</b>
<b>Section 7- Students presentation</b>	<b>728</b>

## **Conference Committee**

**Conference Chair:** Robert M. Brooks, Ph.D., P.E., F. ASCE  
Associate Professor of Civil Engineering,  
Temple University.

### **Members**

Dr. Joseph Picone  
Chair, Electrical and Computer Engineering Department,  
Temple University

Dr. Col. B.G. Crawford, Ph.D., PE  
Director, Mechanical Engineering, West Point, New York

Geraldine Sullivan (Infrastructure and Arrangements)  
Department Manager, Civil and Environmental Engineering, Electrical and Computer  
Engineering  
College of Engineering, Temple University

**Technical Editor:** Naji Khoury, Ph.D., P.E.  
Assistant Professor of Civil Engineering, Temple University

**Associate Editor:** Jyothsna Kavuturu,  
Lecturer, Department of English, St. Joseph's College, Bangalore, India.

## **About Temple University and Location Map**

The venue is at the College of Engineering, 1947 N. 12<sup>th</sup> Street, Temple University, Philadelphia, PA 19122. Information about the university and the location map may be found at the link below.

[http://www.temple.edu/maps/documents/TUMain\\_map.pdf](http://www.temple.edu/maps/documents/TUMain_map.pdf)

# **Keynote Address Speakers (to be presented on October 29, 2011)**

**Dr. Walter Buchanan- Engineering Technology and Future of the Profession  
Opportunities and Challenges**

**Dr. Frank M. Croft- Ohio State's First-year Engineering Program**

**Dr. Dennis John Fallon- Change in Engineering Education One Professor View  
A Look Backwards and Forward**

**Dr. Ted E. Batchman- Reflections on Engineering Education: Past, Present, Future**

**Dr. Clive I. Dym- Design for Sustainability: An Ethical Constraint (Absent)**

**Dr. Ramesh K . Agarwal- Sustainable Product Design in all Disciplines of Engineering  
(Absent)**

### **Dr. Walter W. Buchanan**

Dr. Buchanan is the J. R. Thompson Endowed Chair Professor and Head of Engineering Technology and Industrial Distribution at Texas A&M. He received his Ph.D. and J.D. from Indiana University, and his BSE and MSE from Purdue. Walt is a P.E. in six states and a Fellow of ASEE and NSPE. He has written over 100 papers on engineering technology education, is a past member of the Board of Directors of NSPE, and is currently ASEE President-Elect.

## **Engineering Technology and Future of the Profession, Opportunities and Challenges**

Walter W. Buchanan and Robert J. Herrick  
Texas A&M University, Purdue University

### **WALTER W. BUCHANAN**

Dr. Buchanan is the J. R. Thompson Endowed Chair Professor and Head of Engineering Technology and Industrial Distribution at Texas A&M. He received his Ph.D. and J.D. from Indiana University, and his BSE and MSE from Purdue. Walt is a P.E. in six states and a Fellow of ASEE and NSPE. He has written over 100 papers on engineering technology education, is a past member of the Board of Directors of NSPE, and is currently ASEE President-Elect.

### **ROBERT J. HERRICK**

Professor J. Herrick is Purdue University's Robert A. Hoffer Distinguished Professor of Electrical Engineering Technology and former Purdue Electrical and Computer Engineering Technology Department Head. He received his MSEE from Purdue University under the Bell Telephone Laboratory fellowship program, and his BSEE from Michigan State University. He has served in academic, professional society, and engineering leadership for over 30 years.

# **Engineering Technology and Future of the Profession, Opportunities and Challenges**

Walter W. Buchanan and Robert J. Herrick  
Texas A&M University, Purdue University

## **Abstract**

This paper gives an overview of engineering technology as an academic discipline and discusses the future of its graduates including their opportunities and challenges. Potential careers and examples of high visibility alumni will also be presented.

## **Origins**

The origins of engineering technology as an academic discipline goes back at least to the 1940s when engineering technicians were educated in two-year schools. One of the first Technology Accreditation Commission (TAC) of ABET (then called the Engineers' Council for Professional Development (ECPD). Later it was renamed the Accreditation Board for Engineering and Technology. Now it is named simply ABET, Inc. Associate degrees were awarded by the Benjamin Franklin Institute of Technology (then called the Franklin Institute of Boston) in 1947. [1] These programs very successfully educated engineering technicians and made them a valuable part of the engineering team.

After Sputnik was launched in 1957 by the Soviet Union, leaders in the United States became very concerned that the Russians were surpassing the U.S.A. in engineering. As a result, more mathematics and science was pumped into the engineering curriculum. Something had to give and that was experiential learning laboratories with most of the engineering classes. As a personal aside, when one of the authors majored in electrical engineering at Purdue University, only five or six of his engineering classes had laboratories with them. Later when he became a faculty member teaching electrical engineering technology, he was surprised and pleased to find that all of the engineering technology classes had laboratories associated with them except one.

When the graduates of the new engineering curricula hit industry in the early 1960s, employers found that they did not know their way around the laboratory. This was not a big problem at first since that was the heyday of the space program and our race to the moon. The big aerospace companies had cost plus contracts with the government and so could afford to let these new graduates spend several months getting up to speed in the laboratory. Additionally, there was still a large cache of experienced engineers to mentor the younger smaller group of fledgling graduates into the "practice" of engineering. Later when the economy cooled off, things became much more competitive and companies could not afford the multi-year learning curve of these new breed of engineering graduates. The result was the development of an engineering technology baccalaureate degree, the first accredited by the Engineers' Council for Professional Development at Brigham Young University in 1967. [2] Although these graduates were considered engineering technologists academically, this term never caught on in industry and the vast majority of these BSET graduates were given position titles in engineering. It has also been shown that the majority of engineering

jobs can be held by engineering technology bachelor graduates, and in fact, approximately 35 states provide a path for engineering licensure as a Professional Engineering (PE). [3] There was an attempt around this period to call the engineering degree “engineering science” and the engineering technologist degree “applied engineering,” but this never happened.

## **The Present**

The engineering technology degree, whether an associate degree or a baccalaureate degree, has become a valuable credential. Graduates of both these degrees have been successful as technicians and engineers. In the Electronics Engineering Technology, Telecommunications Engineering Technology, and Manufacturing and Mechanical Engineering Technology programs at Texas A&M University, many graduates have had great success, both technically and in management. Similar examples exist throughout the United States in institutions such as the University of Dayton, Kansas State University, Pennsylvania State University, Purdue University, Texas A&M University, and many more. Many engineering technology graduates have started their own companies or rose high in the ranks of a major corporation. A sampling of such alumni successes follows.

### University of Dayton:

James E. Stitt; 1971 BSET degree; President and CEO of Cutco Corporation for many years, Olean, NY; Jim was featured on a segment of the History Channel's Modern Marvels series on "The Worlds Sharpest," processing of Cutco knives was featured on the show. Cutco originated in 1949 as a subsidiary of ALCOA, the multinational aluminum company. Jim joined ALCOA's Wear-Ever consumer products division in 1972 after graduating from UD and then moved to Cutco in 1975. He guided the company through a management buyout from ALCOA in 1985 and continued growth and acquisitions of other companies.

Alfred B. England; 1982 BSET; One of the principals of Strandex Corporation, a company that licenses proprietary extrusion processes that use wood fibers and a variety of resins to produce composite materials for deck board, and special extruded shapes used primarily in the building construction industry. He started his career with Milacron Company, where he rose to high level management positions and where he demonstrated creative approaches to the improvement of extrusion processes.

Daklak Do; 1989 BSET; President and Founder of Advanced Engineering Solutions Company in Springboro, Ohio; Daklak left Vietnam in 1975 at the end of the U.S. involvement in military action in that country. He traveled under treacherous conditions to escape the turmoil in Vietnam. He eventually made his way to Dayton, Ohio where he supported himself and worked his way through an associate degree in Mechanical Engineering Technology at Sinclair Community College. He immediately transferred to UD and completed the BSET in 1989. After working for a tier one supplier to the automotive industry for a few years, he started his own company producing precision molds for carpets for many brands of automobiles, selling the molds to his former employer and others. The company expanded quickly and made several moves before building the present facility in Springboro which itself has been expanded.

Robert Weimer; MCT graduate - 1970 BSET; Vice President - Quality, Engine Business for Cummins, Inc., a leader in high capacity diesel engines based in Columbus, Indiana.



Robert England; EET graduate; He served as a vice president of Texas Instruments Company in Texas for several years.

Jeffrey J. Sopko; EET graduate, 1970 BSET; Attorney at Law; Patent Attorney; Managing Partner of Pearne, Gordon, McCoy, & Granger, a major patent law firm in Cleveland, Ohio. Jeff served in Vietnam after graduation and completed law school shortly after returning from service.

Arvin L. Jones; BSET 1977; Long career in manufacturing management at General Motors Corporation. Appointed manufacturing manager - Castings and Components Sector - for General Motors Powertrain (GMPT). (2003). Began his GM career in 1977 as an industrial engineer in Dayton, Ohio. He advanced within the manufacturing and engineering organizations until he obtained his current position.

Thomas V. Chambers; BSET 1974; Long career in manufacturing management with General Motors Corporation; Business Unit Manager for the former Delco Moraine Division in the Dayton area (Virtual equivalent to President & CEO for a large corporation); Manager of the GM-France brake division, and other assignments; In 2007 was President and COO of Metadyne Corporation in Plymouth, MI.

Kenneth J. Monnier; BSET 1983; Vice President for Engineering at Emerson Climate Technology, Inc., Sidney, Ohio. He has continuing contact with and support of UD through projects in the School of Engineering's Design and Manufacturing Clinic and Innovation Center.

William E. Sopko, Jr.; BSET 1971; President, William Sopko & Sons, Inc., Cleveland, Ohio; Took over the ownership and management of the successful company founded by his father soon after graduation due to the untimely death of his father. Continuously expanded the company through acquisition of related manufacturing companies: Manufacturer of heavy stampings for the truck industry; Supplier of repair parts for grinding equipment.

#### Kansas State University:

Melvin Bergkamp (Mechanical Engineering Technology) – is the owner of Bergkamp Inc. in Salina, Kansas.

Doug Oliphant (Electronic Engineering Technology) –VP of Engineering for KASA Industrial Controls in Salina, Kansas.

Julie Martin Maher (Data Processing) – She is the bluesphere director for Kansas, which is a group within EDS (Electronic Data Systems) E.solutions division in Plano, Texas.

Mel Kejr (Mechanical Engineering Technology) – He is founder and president of Kejr, Inc. in Salina Kansas. Kejr Inc. sells products around the world under the brand names of Geoprobe and Veris Technologies.

Rex Eberly (Civil Engineering Technology) – Rex is Vice President of Ballou Construction in Salina, Kansas.

Terry Krause (Computer Engineering Technology/Technology Management) – He is a Nuclear Quality Manager for Burns & McDonnell in Leawood, Kansas.

Jennifer Johnson (Data Processing) – She is an Executive Vice President for Sunflower Bank. Jennifer in Salina, Kansas.

Bob Moeder (Computer System Technology) – Bob is President of Kroger Co., Central Division in Indiana.

Bob Kuhn (Civil Engineering Technology) – He works for Ark Wrecking Company of Oklahoma. Previously, Bob worked for Utility Contractors Inc, a subsidiary of Martin K. Eby Construction in Wichita, KS. After serving in various engineering and management positions, Kuhn was transferred to Oklahoma as President and Area Manager of the Oklahoma operations.

### Old Dominion University

Robert Billingsley - (Civil Engineering Technology – 1976) He currently is the Director of Structural Projects, Norfolk Southern in Roanoke, VA; and has been in the freight rail industry for 34 years. At this time he is overseeing the construction of the “Heartland Corridor,” making the tunnels large enough for double stacked rail traffic between Hampton Roads and the Midwest. This huge public-private partnership project involves enlarging tunnels to accommodate double stacked trains and eliminating nearly 240 miles from the freight route between Virginia ports and terminals in the Midwest.

Gary D. Camper - Magna Cum Laude with a BS in Mechanical Engineering Technology (BSMET) – 1984) – Began his career with Babcock & Wilcox (B&W) in Lynchburg, VA. After several different Unit Manager positions, he was promoted to Section Manager in 1994, a position he held until 1998 when he was promoted to Project Manager of the Virginia Class program becoming responsible for the technical, financial, and scheduler performance of the multi-million dollar project. His current position is Engineering Department Manager. Gary notes that the Engineering Technology degree is a perfect fit for manufacturing industries as the candidates come prepared for more “hands on” work with the factory floor and are also well suited for traditional engineering work as well.

John Hartline – (Summa Cum Laude, BS in Engineering Technology – 1999; receiving several awards including the Lee M. Klinefelter Award for Overall Excellence in Engineering Technology and the Faculty Award for Academic Excellence in Engineering Technology) – Director of Land Based Systems with Ursa Navigation Solutions, Inc.; ranked by Inc. Magazine as the 8<sup>th</sup> fastest growing engineering company in 2009. After serving 27 years, he retired from the U.S. Coast Guard. While there he specialized in Electronic Charting and Navigation systems. John also holds a master’s degree in Systems Engineering.

Wilbert W. James – (BS in Mechanical Engineering Technology – 1978) – President of Toyota Motor Manufacturing, Kentucky, Inc. in Georgetown, KY. During his 20 year career, he encompassed many career moves including being named Vice President of Manufacturing in January 2003. He was also General Manager of Assembly, responsible for engineering, maintenance, production and internal parts conveyance for Kentucky’s two assembly lines. Along with the Plastics organization, he also was General Manager of Production Administration with responsibilities that included coordination of Production Support, Facilities, Environmental, Planning and Project Management.

Winfred D. Nash – (BS in Electrical Engineering Technology); MS in Business Administration from Duke’s Fuqua Business School; and attended the Advanced Executive Management training at Northeastern University) – Vice President and General Manager for Nuclear Products Division at Bwx Technologies, Inc.; and served as President of Babcock & Wilcox Nuclear Operations Group, Inc., at McDermott International, Inc. During his tenure with the company he was promoted to foreman and later supervisor, prior to holding senior management positions. He has held the positions of Vice President & General Manager at the Lynchburg facility.

Christopher Roberts - BS in Civil Engineering Technology – 1997, Summa Cum Laude) Began his career in 1999 with Clark Nexsen Architecture and Engineering in Norfolk. He serves as Team Leader/Lead Inspector, performing bridge safety inspections throughout the continental United States for clients such as the Virginia Department of Transportation and the Federal Highway Administration. He is also responsible for the design of bridge repair and rehabilitation projects. In 2006, he was made an associate with the firm. Chris is a P.E., licensed in Virginia and the District of Columbia and is also a member of the NSPE and the ASHE. He served as an adjunct professor of Civil Engineering Technology from 2001 -2007.

Billy Keen - BS in Mechanical Engineering Technology – 1981  
Retired as a Vice-President of Engineering for Phillip Morris Corporation in Richmond, Virginia

Judy Carboni - BS in Mechanical Engineering Technology – 1981  
Retired as a Vice-President of Production for Phillip Morris Corporation in Richmond, Virginia.

#### Pennsylvania State University:

Dr. Hooshang Heshmat is Co-Founder and President & CEO/Technical Director of Mohawk Innovative Technology, Inc. (MiTi), an applied research and product development company specializing in mechanical components (e.g., bearings, seals, dampers and piston rings, including fluid film, dry lubricant and magnetic systems), testing and measurement techniques and the design and fabrication of rotating machinery systems and component test equipment, who has now established a premier biotechnology company in the Albany area based on their unique heart pump system.

Tom Baloga, Vice President of Engineering, BMW North America  
Woodcliff Lake, NJ

Thomas Perry, PE  
Director, Education & Professional Advancement  
American Society of Mechanical Engineers, New York, NY

Michael Sullivan, Electrical Engineering Technology Graduate  
Senior Vice President of Pepco Operations

#### Purdue University

Purdue University’s section is composed of a sampling of its Distinguished Technology Alumni (DTA) award winners from Bachelor of Science (BS) programs in engineering technology programs in four departments: Aviation Technology (AT), Electrical and Computer Engineering Technology (ECET), Industrial Technology (IT), and Mechanical Engineering Technology (MET).

The B.S. programs included are Aviation Engineering Technology (AET), Electrical Engineering Technology (EET), Industrial Technology (IT), Mechanical Engineering Technology (MET) and Manufacturing Engineering Technology (MfET). The captions that follow are based upon each person's career at the point in time that the DTA Award was given.

Galen M. Gareis –DTA 2003, BS EET 1983. In 2003, he held the position of the Senior Product Project Engineer, Belden Wire and Cable in the Electronics Division. Galen Gareis focused on product engineering at Belden Wire and Cable's Electronic Division. During his tenure in product engineering, he has individually and co-awarded over seven patents and has submitted over 18 patent applications and trade secrets, placing him second-highest for patents awarded to a single individual in Belden's 100-year history.

Jaime Arnett – DTA 2004, BS MET 1980, MS 2000. In 2004, he held the position of Associate Engineering Consultant for Eli Lilly & Co. Jaime's ingenuity resulted in more than 48 U.S. Patents and an additional seven Patents Pending during his 19-year tenure at Bell Industries. The CEO of AT&T recognized his quest for discovery in 1994 with an AT&T Patent Award for "Significant Importance to AT&T's Commercial Success."

Christopher Baker – DTA 2004, BS EET 1989. In 2004, Chris held the position of Vice President of Sales & Customer Development at Pitney Bowes Inc. Chris started his own company following graduation. His company, MailCode Inc., provided mail-processing solutions through mail sorting equipment, software applications and multi-line optical character recognition (MLOCR) technology. His patented technology is licensed to all global major scale manufacturers. In 2001, Pitney Bowes acquired a controlling share of MailCode Inc. and in 2002, Christopher became vice president of U.S. sales and customer development for Pitney Bowes. Pitney Bowes Inc. Chris' expertise in the field of mail processing has led to four U.S. Patents and a Recognition Award by the U.S. Postmaster General.

Steven Lyman – DTA 2005, BS MET 1973. In 2005, Steven was a Specialist with the DaimlerChrysler Corporation. Steven was the lead vehicle dynamics and chassis specialist for all high performance vehicle derivatives created by street and racing technology at DaimlerChrysler. Steven's innovative spirit fostered the completion of numerous publications and articles and he has secured several patents.

Rick Vanderwielen – DTA 2005, BS EET 1978. Rick was the founder and CEO of Indiana Automation, Inc. (later renamed to integrator.com), Flexware Innovation Inc. and five other companies. He was a pioneer in the design, development and manufacture of automatic control systems for correctional institutions, previously only manually controlled in the USA. This led to significant growth into the integration of automated systems.

Richard K. Price – DTA 2006, BS EET 1975. In 2006, Dick was the Director of Business Continuance and Emergency Management and Middle East Operations for Verizon. After graduation, he joined MCI (Microwave Communications Incorporated). Dick has been with MCI (now Verizon Business) for over 30 years. He was responsible for planning, writing, coordinating, implementing, and overseeing the business continuance plans for the worldwide operations, engineering, and implementation organization. He was also charged with managing the National Emergency Coordinating Center (NECC) as well as the tactical response to all incidents involving hazardous materials, bio-terrorism, and major natural disaster events. In addition to identifying new worldwide business ventures, Dick oversaw all operations in Iraq and the Middle East.

John S. Sofia – DTA 2006, BS MET 1984, MBA 1993 from University of Detroit Mercy. In 2006, he was the Vice President of Quality Assurance and Customer Satisfaction, American Axle & Manufacturing. John is responsible for maintaining exceptional world-class quality at all of the AAM manufacturing facilities—efforts that have made AAM a benchmark among its peers. In addition, he utilizes data, facts, and trends to establish strategies that save AAM customers millions of dollars in warranty costs.

Joseph M. Zachman – DTA 2007, BS MET 1983, MS 1993 from General Motors Institute. In 2007, he was Senior Vice President of the Wabash National Corporation. His career has spanned several companies since he graduated: Delco Electronics, Sanmina Corporation, CDR Corporation, and TTM Technologies. Joe has held increasingly responsible positions in engineering and operations throughout his career. As a senior vice president at Wabash National in Lafayette, he was responsible for all manufacturing, manufacturing engineering, safety, quality, production control, maintenance, and continuous improvement.

Allen R. Glassburn – DTA 2008, BS EET in 1974, MA 1983 from Ball State University, MS 1987 from Massachusetts Institute of Technology (MIT). Allen is vice president of Regulatory and Finance for I&M Power and oversees the integration of the company's financial and regulatory strategies, and corporate budgeting. In his current role, he is the primary liaison for coordinating financial and regulatory activities between I&M Power and its parent company American Electric Power (AEP). He was appointed to his current role in 2009 after serving as the company's director of Business Operations Support, when he was responsible for financial planning and coordination with all organizations that influence operating company results.

Thomas D. Hjertquist – DTA 2008, BS IT 1976. In 2008, he was Vice President of Maintenance and Purchasing, Landair Transportation. In his position as a vice president at Landair Transportation, he was responsible for all asset management processes, from purchasing to disposal. His resume highlights several accomplishments, including increased profits, higher employee and customer satisfaction, reduced costs, and more positive safety records.

Mark A. Stidham – DTA 2008, BS MET 1979. In 2008, Mark was President of North American Exhaust Division for Faurecia Exhaust Systems Inc. Within seven years of his graduation, Mark Stidham had become a vice president for Atwood Automotive in Rockford, Illinois. His scope of responsibility has ranged from engineering to marketing to management. At Faurecia Exhaust Systems, Stidham oversees the operations of eight manufacturing facilities in the United States and Mexico.

Donald W. Malackowski – DTA 2009, BS EET 1988. He is the Vice President of Advanced Technology Developments of Stryker Instruments. As vice president of Stryker Instruments' Advanced Technology Group, Malackowski and his team are responsible for developing technology platforms and architectures for integration into Stryker's wide range of medical products. He has been honored four times by his employer with the Shaping the Future Award. He has been granted 15 patents, and he has another 22 pending with the U.S. Patent Office.

Ken Harness – DTA 2009, BS AET 1989, MBA 1999 at Oakland University. He is Chief Operation Officer for Diamond Aircraft Industries. As the director of propulsion systems for Eclipse Aviation, he was named co-inventor on three patents related to the development of the world's first commercially viable halon replacement system. And as Eclipse's vice president of engineering, he

managed the development and certification of the first very light jet. The project earned the 2005 National Aeronautic Association Collier Trophy for “greatest achievement in aeronautics or astronautics in America.”

James E. Elsner – DTA 2010, BS EET 1997. He currently serves as Division Vice President of Engineering at Butler America LLC. His 28 years at the company included positions of increasing responsibility, from project engineer to engineering manager. While there, he was awarded two patents in multi-layer ceramic packaging, and he has another one pending. Since 2006, Elsner has worked for Butler International, first as operations manager and now as a vice president for Butler America LLC.

Brad Morton – DTA 2010, BS MET 1977, MBA 1986 from Indiana University. He is currently President of Aerospace Group of the Eaton Corporation. He joined Eaton in 2002 as vice president of Aerospace Fluid Systems and was promoted to lead the Aerospace Division in 2003. Today, he is responsible for leadership of four divisions worldwide.

Craig Schauss – DTA 2011, BS EET 1983. Craig is president of Vetronix Research Corporation. During a six-year tenure with General Dynamics Land Systems, he designed and developed the serial communication protocol and custom-integrated circuit implementation of the MIC Bus technology. He received a U.S. patent and several international patents for this technology, which is used in several U.S. military programs. In 1990, he formed his own company, Vetronix Research Corporation. He is helping keep America safe as a supplier of “rugged electronics” to governmental and defense contractors.

#### Texas A&M University:

David O. Craig was director of IT Back Office Applications for Reliant Resources, Inc., in Houston, Texas, responsible for development, maintenance, and operations of the Internet and Intranet applications required to support the corporate and retail groups. Prior to that, he was with Compaq Computer Corporation as manager in the Advanced Engineering Group, responsible for the design and implementation of the systems and automated equipment required to manufacture and test an advanced digital data monitor. Craig was a staff software engineer with IBM Corporation for over nine years where his expertise was in the development of custom real-time control systems, manufacturing execution systems, and automated manufacturing systems for Fortune 500 companies. He holds two B.S. degrees from the Texas A&M including MMET. He holds three U.S. patents, has coauthored 11 publications in IBM's Technical Disclosure Bulletin, and was recognized with a First Level Invention Award.

Michael R. Wilkinson – CEO of Paragon Innovations, one of the nation's leading providers of product development and engineering services. Customers include 3M, B Braun Medical, Hitachi, Matsushita, and Motorola, among others. He has served on the Board of Directors of Metroplex Technology Business Council (MTBC) and is a former chairman of the American Electronic Association's (AEA) North Texas CEO roundtable. Wilkinson graduated in 1986 from Texas A&M University with a degree in electrical engineering technology.

James Davis - Engineering Technology, 1973  
President, Network USA  
Carencro, Louisiana

John W. Crenshaw - Engineering Technology, 1981  
Vice President Engineering and Construction, STP Nuclear Operating Company  
Houston, Texas

David Rencurrel - Electronics Engineering Technology, 1982  
Senior Vice President, Units 1&2, STP Nuclear Operating Company,  
Nuclear Navy Officer, USNR

Wade Hilty- Mechanical Engineering Technology, 1980  
President and CEO, Competition Roofing, Incorporated  
Houston, Texas

Dave A. Mason - BS in Manufacturing ET'02, Master of Project Management'07 and MBA'08,  
International Business Keller Graduate School of Management  
747-8 Final Body Join Hardware Manager/ Manufacturing Engineer; Manages all major issues that  
impede the assembly of 747-8 Freighter and Intercontinental aircraft in Final Body Join position of  
Production Assembly, identify, manage and implement production process improvement projects  
that support rate improvement in the 747-8 Final Body Join position.

Dave Irek – BS'94 in Electronics Engineering Technology  
First worked for Fujitsu as a systems engineer. Started at Cisco in 1999 and advanced to a Senior  
Business Development Manager for Cisco's IP Next Generation Networks division and traveled  
world-wide developing new business relationships as part of his position. He found the  
communications skills that it provided very important and said his degree opened many doors for  
him and let him hit the ground running. He recommends any highly motivated, hands-on oriented,  
technically driven individual to pursue their degree within engineering technology.

Jeff Gilstrap - BS'04 in Manufacturing Engineering Technology  
Manufacturing Engineer Vought Aircraft, Supply Chain with Steelcase, and currently Account  
Manager with Harris Packaging. Major accomplishments are big international sourcing experience  
with Steelcase, key note speaker to North Texas APICS, and Featured in March 2006  
Manufacturing Engineering Magazine as "New Faces of Manufacturing" award recipient.

John F. Price - BS'85 in Engineering Technology  
General Manager of National Oilwell Varco (NOV) in Navasota, Texas, the world's largest drill  
pipe manufacturing facility. NOV. At the Navasota plant, with over 800 employees, drill pipe and  
drill stem accessories are manufactured for use globally. He was a Product Engineer, then Senior  
Product Engineer, both in Navasota and at the Grant Prideco S.A. de C.V. facility in Veracruz,  
Mexico. He eventually became the Manager of Quality and Process Improvement, before being  
promoted to General Manager. He holds a patent for an upset forging process for drill pipe, and he  
developed the SmoothEdge(tm) tool joint design.

Angie Hill Price - BS'85 in Engineering Technology  
MS in Industrial Engineering and PhD in Interdisciplinary Engineering, Associate Professor of  
Manufacturing and Mechanical Engineering Technology at Texas A&M University in College  
Station. Has received many award at Texas A&M for teaching, research, and service. Past Speaker  
of the Faculty Senate.

## The Future

The authors predict a bright future for engineering technology graduates, whether at the associate or baccalaureate degree level. There is a real need in industry for technicians and practicing engineers, who are good at hands-on applications and can “hit the ground running” on graduation, which is the goal of any good engineering technology program. Small companies, especially, cannot afford to train starting engineers to find their way around the laboratory whereas the engineering technology curriculum is designed around laboratory experiential work, so the engineering technology graduate indeed is ready for work in the laboratory and in production facilities. Combined with management training, there can be a bright future for an engineering technology educated person to rise to the highest levels in the management structure of a company.

## References

1. 1984 Annual Report, Accreditation Board for Engineering and Technology, New York, NY, p. 144.
2. 1984 Annual Report, Accreditation Board for Engineering and Technology, New York, NY, p. 143.
3. Buchanan, W.W., McNeill, P.R., & Petersen, O.G., “Professional Registration for Engineering Technology Graduates,” Journal of Engineering Technology, 15 (1), 12-18, Spring 1998, American Society for Engineering Education, Washington, D.C.

## Bibliography

### Walter W. Buchanan

Walt Buchanan is J.R. Thompson Endowed Chair Professor at Texas A&M University. He has served in professorial and administrative positions at Northeastern University, Oregon Institute of Technology, Middle Tennessee State University, University of Central Florida, and Indiana University-Purdue University Indianapolis, was an electronics engineer for the Naval Avionics Center, an engineering officer for the Navy, an aerospace engineer for the Boeing and Martin Companies, as well as an attorney for the Veteran’s Administration. He is a Fellow and served on the Board of Directors of both ASEE and NSPE, is a Senior Member of IEEE and SME, is Past-Chair of the Professional Engineers in Higher Education of NSPE, and is a Past President of the Massachusetts Society of Professional Engineers. Buchanan is a past member of the Executive Committee of TAC of ABET, is on the editorial board of the *Journal of Engineering Technology* and the advisory board of the *Journal of Engineering Education*, has authored or co-authored over 100 publications, and has been a principal investigator for NSF grants.

Walt is the current President-Elect of ASEE. He has received the ASEE Distinguished Service Citation and Centennial Certificate, the ASEE James H. McGraw Award, and the ASEE Frederick J. Berger Award. He was selected as a Highly Accomplished Engineering Educator by *ASEE Prism* in 2005. Buchanan was a charter member of the Tau Alpha Pi Board of Directors and served as President in 2003. Offices within ASEE include PIC II Chair, Engineering Technology Council Chair, Engineering Technology Division Chair, Engineering Research and Methods Division Program Chair, Constitution and By-Laws Committee Chair, and member of the Accreditation Activities Committee. Buchanan holds a B.S.E and M.S.E. from Purdue University, and a B.A., J.D., and Ph.D. from Indiana University. He is a registered P.E. in six states and a retired member of the Indiana State Bar.

### Robert J. Herrick

Robert J. Herrick is Purdue University’s Robert A. Hoffer Distinguished Professor of Electrical Engineering Technology (EET). He has served as the Department Head of the Electrical and Computer Engineering Technology Department at Purdue University for 10 years and was Assistant Department Head in the 1990’s. Formerly, he served as Engineering Technology Department Chair and EET Program Leader at the University of Toledo in the 1980’s. He held the positions of Senior Member of Technical Staff at International Telephone and Telegraph’s Advanced International Technology Laboratory, and was a member of the Technical Staff at AT&T’s Bell Telephone Laboratories in the 1970’s, developing the early generations of digital electronics switching systems. Professor Herrick’s professional leadership roles have included National President of Tau Alpha Pi Honorary Society; Chair and



Secretary of the Engineering Technology Leadership Institute; Treasurer of the ASEE Engineering Technology Division; Co-founder and current Chair of the ASEE Engineering Technology Council standing committee of the ET National Forum; Editor-in-Chief of the IEEE Press Editorial Board and Editor of its Electronics Technology Series; Chair of the Frontiers in Education (FIE) Steering Committee; and Chair and Proceedings Editor of North Central and Illinois-Indiana Section conferences. He currently serves as a TAC of ABET program evaluator for IEEE and has served as an ASEE campus representative at Purdue University and the University of Toledo.

Professor Herrick has been recognized with national, regional, university, college, and department awards and honors for outstanding teaching and professional service, including: ASEE's Frederick J. Berger Award, Purdue's life-time Murphy Teaching Award for Outstanding Undergraduate Teaching; Inductee into Purdue University's Book of Great Teachers (an honor reserved for only 267 faculty in the history of Purdue University at the time of his induction); Purdue Teaching Academy Fellow and Executive Board (charter member); the Ronald Schmitz Award for Outstanding Service to FIE. Professor Herrick received his B.S. degree in electrical engineering from Michigan State University (1968), and his M.S. degree in electrical engineering from Purdue University (1969) as part of the Bell Labs fellowship program.

**Dr. Frank M. Croft, Jr.**

**Associate Professor of Civil & Environmental Engineering and Geodetic Science  
The Ohio State University**

FRANK M. CROFT, JR. is an Associate Professor of Civil & Environmental Engineering and Geodetic Science at The Ohio State University. Prior to assuming this position at OSU, he served on the faculty of the Speed Scientific School, University of Louisville (1976-1984) and West Virginia Institute of Technology (1973-1976). Before beginning his academic career, Croft was an associate engineer/scientist with the Douglas Aircraft Company in Long Beach California (1969-1973). Croft holds a bachelor of science degree in aerospace engineering, earned at Indiana Institute of Technology (1969). His advanced degrees are a master of science in engineering (civil engineering) which was received in 1977 from West Virginia College of Graduate Studies, and his Ph.D. degree in Civil Engineering from Clemson University in 1984. Croft has been an active member of ASEE since 1973 and has served as the 1989-1990 chair of the Engineering Design Graphics Division and the 1995-1996 chair of the North Central Section. Also, he served on the ASEE Board of Directors as Zone II Chair from 1998-2000 and was Vice-President of Professional Interest Councils and Professional Interest Council III Chair from 2003-2005. He is currently a Life Member of ASEE and is an ASEE Fellow. Croft has received several awards including the Southeastern Section Dow Outstanding Young Faculty Award in 1982, the North Central Section Best Paper Award at the 1987 NCS Conference, the EDGD Distinguished Service Award in 1997, the North Central Section Distinguished Service Award in 2002, the Charles E. MacQuigg Outstanding Teaching Award at Ohio State in 1994, and in 2009, the Department Outstanding Professor Award (OSU-CEEGS) 2009, and the Orthogonal Medal from North Carolina State University in 2009. Croft has been the lead professor for Engineering Summer Academy, a program designed to attract outstanding high school students to engineering since 1985. He is a registered professional engineer in Kentucky.

## **Ohio State's First-year Engineering Program**

The First-year Engineering Program got its start in 1992. Prior to this date, the first year engineering experience for students was composed of a four credit course in engineering graphics which included instrument drawing and some CADD. At that time, the engineering faculty, felt that students were not getting the proper exposure to what engineering was all about through the graphics course and thought that some alternative could be found that would enhance student retention in engineering. Like a lot of universities, the engineering program at OSU was experiencing high drop-out rates. There were many reasons for this, but the most significant one was that engineering students in the first year were not spending a lot of time in engineering (only the graphics course) and they were having to endure the rigors of physics, math, and chemistry without seeing any connection to engineering.

In the 1990s, The College of Engineering at Ohio State became a part of the Gateway Coalition that was devised to enhance the first year experience. Drexel University, a member of the coalition, initiated what it called the E4 program. In this program, Math and Physics are combined, Chemistry and Biology are combined, Engineering had both a lecture portion and a hands-on lab portion, and humanities were combined with communication and had a technical and non-technical component. The results of implementing the E4 program at Drexel, showed a retention rate of greater than 60% of the first-year engineering students and feedback received from co-op employers was very positive. Seeing these results, OSU decided to adapt the Drexel E4 model in a slightly modified format.

In the early days, the OSU adaption involved a select and dedicated faculty from the College of Engineering and the College of Mathematics and Physical Sciences. Engineering Mechanics was combined with Math with accelerated Calculus, Statics, Particle Dynamics, and Rigid Body Dynamics. Engineering Fundamentals and Graphics as well as the programming course included a hands-on laboratory where students could experience different engineering disciplines throughout the first two quarters and thus they spent more productive time in engineering. First year students were offered the fundamentals and programming classes in two separate sequences: The Fundamentals of Engineering (FE) format and the Fundamentals of Engineering Honors (FEH) format. Both sequences include hands-on labs, with engineering “up-front” and team based design/build introduced early and often.

In the FEH format, the students enrolled had to be admitted to the University Honors Program. This means they had to achieve score of 30 on the ACT, be ranked in the top 10% of their high school graduating class and have a sustained record of extra-curricular activities and demonstrated leadership. In the FE format, students had to be admitted to the College of Engineering.

Historically, the timeline for implementing the First-year Sequences is shown in Figure 1. Planning for FEH and FE began in 1992. From 1992 through 1996, Pilot sections based on the Gateway approach and the Drexel E4 model were introduced along with control sections in order to ascertain the validity of plan. The first section of FEH was approved and offered in 1997. At the same time planning for the FE sections were taking place with pilot studies being conducted in 1997 & 1998. The FE program was approved in 2000 and began operation.

## Timeline for First-Year Sequences

<b>Year</b>	<b>Activity (Students)</b>	<b>Year</b>	<b>Activity (Students)</b>
• 1992	Planning for Gateway		
• 1993	Pilot 1 (30)		
• 1994	Pilot 2/3 (38/65)		
• 1995	Pilot 4/5 (37/64)		
• 1996	Pilot 6 (64)		
• 1997	FEH Approved (71)	• 1997	Planning for FE
• 1998	FEH (105)	• 1998	Pilot 1 (105)
• 1999	FEH (173)	• 1999	Pilot 2 (275)
• 2000	FEH (218)	• 2000	FE Approved (681)
• 2001	FEH (252)	• 2001	FE (~800)
• 2002	FEH (250)	• 2002	FE (~1,050)

Theta Tau 2007

The Ohio State University

8

Figure 1. Timeline for implementation of the FEH and FE Sequences

In looking at the FEH sequence and the FE sequence, the following comparison can be made: In FEH, there is an emphasis on hands-on learning and design. There is coordination among the FEH core classes. There are weekly meetings among the faculty involved in teaching physics, math, and engineering to enhance the experience of the students. The courses are very challenging. Students take a 3 course sequence (Engr H191, Engr H192, Engr H193) which account for 12 credit hours over the year. In FE, there is also an emphasis on hands-on learning and design; however, there is no coordination among freshman classes. The courses are challenging, but not to the extent as the FEH classes. Students take a 2 course sequence (Engr 181 and Engr 183). Most also take EG 167, a programming course. The total credit hour count over the year for FE students is 10.

When we look closely at FEH, what makes it special? First it is a three course sequence that is very challenging for the students, but also very rewarding. In the first course, Engr H191, students learn the fundamentals of graphics through sketching and use of Autodesk Inventor, a Geometric Modeling Program. They are introduced to hands-on labs and are required to do extensive lab report writing. There is a project in which two person teams design and build a cardboard mechanism (a bridge for a 16" span, or a Christmas ornament shipping carton). There is a competition involving loading the mechanisms until they break and bonus points are awarded to the winners. The second course, Engr H192, involves C and C++ programming. It also involves additional labs that require the students to do extensive lab reports. Another design project is part of this course as well. In the final course, Engr H193, the students are divided into 3 or 4 person teams and are charged with building an autonomous robot that is required to traverse a course and perform various tasks. The course changes each year as do the tasks. This design and build phase of the program requires the students to use the knowledge that was acquired in the first two courses and also requires them to use teamwork to achieve their final goal. Each team is required to document their designs and to present a formal report at the conclusion of the course. A very special part of this program is that there is coordination between engineering, math, and physics throughout the program. There is a weekly meeting of the faculty involved in the honors program

of engineering, math and physics to discuss issues that have arisen and to be coordinate topics that are being introduced so that they make sense for the entire group of students enrolled in the honors program. One example of coordination is that we make certain that mid-term exams in the three areas do not fall on the same day which enables the students to be better prepared. There is a great amount of effort to ensure that the program is properly administered in all three areas, and we think this is rather unique.

In the early years of the program, our concern was with retention of high quality students in engineering. Figure 2 shows some data with this regard. Prior to 1988, the student retention in engineering was very poor. The baseline data shown in Figure 2 shows that less than 40% of the students starting in engineering made it to graduation 4 or 5 years later. After making the changes and introducing FE and FEH, the data in 1998-1999 shows that the control group (FE) retained 55% over the 4 to 5 year period and the FEH group retained over 70%. When you look at the next year, retention rates got even better. It would appear that introducing hands-on labs and faculty coordination have contributed to the retention success of this program.

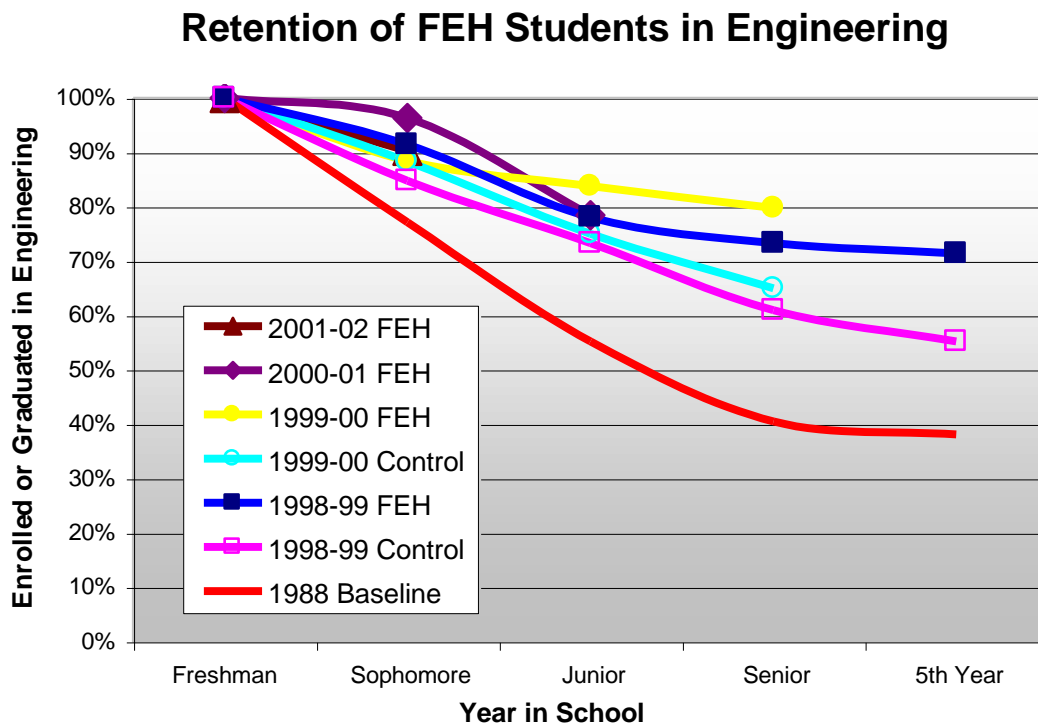
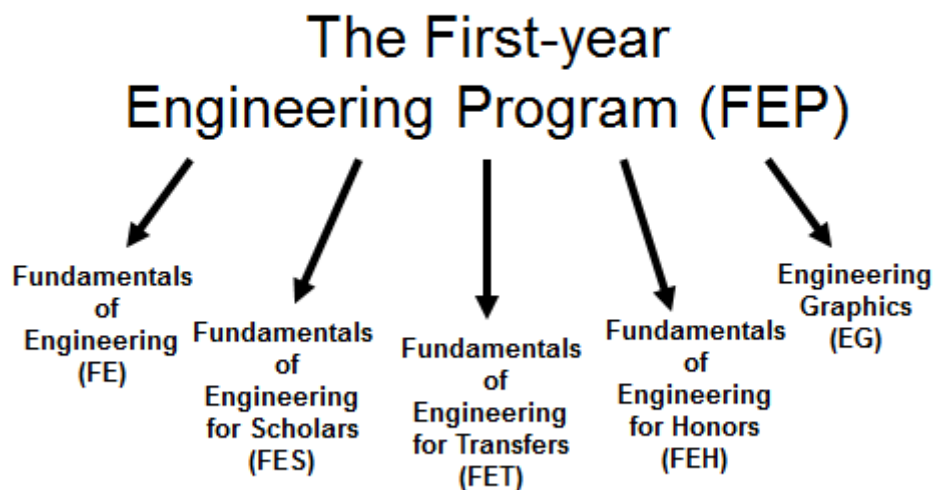


Figure 2. Retention of FEH Students in Engineering

The FE and FEH programs are been evolving since 1997 and some significant changes have taken place. The College of Engineering at Ohio State has created an Engineering Education Innovation Center (EEIC) and the FE and FEH programs are now managed under this umbrella. Managing these programs is not the only task that EEIC has. A new PhD program in Engineering Education has been instituted and it resides in EEIC. EEIC handles the hiring and training of Graduate Teaching Associates (GTAs) and Undergraduate Teaching Associates (UTA or Mentors) that are an integral part of the teaching of FE and FEH. There are over 140 GTAs and UTAs that enable us to run these programs efficiently.

EEIC has expanded its administrative handling of all the programs shown in Figure 3. This incorporates Fundamentals of Engineering, Fundamentals of Engineering for Scholars, Fundamentals of Engineering for Transfers, Fundamentals of Engineering for Honors, and Engineering Graphics. There are still engineering graphics courses offered especially for technology education and a technical elective AutoCad course.



24

Figure 3. The First-year Engineering Program.

The retention rate of students in engineering has been fairly steady over the past decade since the change-over to FE and FEH. Figure 4 shows the retention numbers for 2009-2010 and 2010-2011 for the programs. Data for FE was not available for 2010-2011 for FE. Retention for FE and FEH remains constant at 80% for 2009-2010. The total for all programs in FEP is also over 80%. In 2010-2011, FEH was over 80% as well. These retention numbers speak volumes with regard to the success of the program and the achievement that was sought in retention.

## FEP Course Retention in 2009-2010

Course	Started	Finished	Retained
181	1391	1319	94.8%
183	1169	1113	95.2%
<b>FE Total</b>	<b>1391</b>	<b>1113</b>	<b>80.0%</b>
191H	431	429	99.5%
192H	382	365	95.5%
193H	359	357	99.4%
<b>FEH Total</b>	<b>431</b>	<b>357</b>	<b>82.8%</b>
<b>FEP Total</b>	<b>1822</b>	<b>1470</b>	<b>80.7%</b>

Of the 69 who did not finish FEH, ~half remained in Engineering<sup>6</sup>

## FEP Course Retention in 2010-2011

Course	Started	Finished	Retained
181			
183			
<b>FE Total</b>			
191H	416	416	100.0%
192H	367	357	97.3%
193H	339	337	99.4%
<b>FEH Total</b>	<b>416</b>	<b>337</b>	<b>81.0%</b>
<b>FEP Total</b>			

Of the 79 who did not finish FEH, ~half remained in Engineering<sup>7</sup>

Figure 4. FEP Course Retention Rates for the Past Two Years.

Numbers for the 2011-2012 year indicate that engineering at OSU is growing and is a popular program. During the course of regular and transfer orientation sessions held between May and September, 2011, the College of Engineering welcomed new students into engineering as follows:

New First Quarter First Year Student (NFQF)	~1575
Number of Transfers	~ 100
Total	<u>1677</u>

Compared to 1563 in Au 2010

Based on the retention numbers that we have seen in this presentation, it can be said that the FE and FEH programs are very successful. In FEH we have managed to retain some our best students. Industry recognizes the knowledge and skills developed in FEH as they have made significant contributions of funds and gifts-in-kind to the program. FEH has the faculties of Math, Physics, and Engineering working together for a common goal. The program helps to recruit good students. The success of the program has taken a great deal of hard work from a lot of dedicated faculty, graduate students, and undergraduate mentors. The Administration of the College recognizes the importance that all the components of FEP is to our over-all program.



## **Dr. Dennis John Fallon**

Dennis John Fallon is presently The Citadel Distinguish Professor of Engineering Education. He is formerly the Dean of the School of Engineering and holds the Louis S. LeTellier Chair at The Citadel in Charleston, South Carolina. He received his BSCE from Old Dominion University (ODU) with honors in 1970, and his MSCE and PhD. from North Carolina State University in 1972 and 1980, respectively.

Dr. Fallon's industrial experience includes seven years at Carolina Power and Light Company in Raleigh, NC, two years as Chief Structural Engineer with a consulting firm, and three years with the Underwater Explosion Research Division in Portsmouth, Virginia. He is a Professional Engineer in the State of South Carolina. Dr. Fallon's academic career includes six years as an Assistant Professor at ODU and 22 years at The Citadel where he served as Head of the CEE Department for ten years (1993-2003).

An active member of the Southeastern Section of American Society for Engineering Education (ASEE), Dr. Fallon has held numerous positions within the organization including the Chair of the Civil Engineering Division and the Administrative Unit, Conference Site Coordinator, Newsletter Editor for three years, Technical Program Chair and Instructional Unit Chair from 1994 to 1995, and was elected President of the Southeastern Section from 1996 to 1997 and then again from 2003 to 2004. He has also served for three years as the National Campus Representative and has recently begun a three-year term as Director of the CE Division of the National ASEE. In addition, he served a three-year term as Newsletter Editor of the CE Division. He is completing the second year of a two-year term as the Zone II representative on the National ASEE Board of Directors.

Dr. Fallon has been active in the American Society of Civil Engineers, where he has achieved the grade of Fellow. He has also served as President of the Eastern Branch in Charleston, SC and as Secretary, Vice President, and President of the South Carolina Section of ASCE. He has served the State of South Carolina by judging a number of times the competition for the engineering Excellence Award present annual by the American Council of Engineering Companies (ACEC.) In addition he has supported the state Board of Registration of Professional Engineers by serving on professional panels to evaluate portfolios of individuals seeking registration in the South Carolina

Dr. Fallon has received such prestigious awards as the Cumberland Gap Chi Epsilon Award for Teaching Excellence, the James Grimsley Citadel Teaching Excellent Award, Thomas Evans Best Instructional Paper at the Southeastern Section of ASEE conference in 1990, and a Section Leadership Award from the South Carolina Section of ASCE; he is also a five-time recipient of the Outstanding CE Professor at ODU. Dr. Fallon is a member of Tau Beta Pi, Chi Epsilon, and Phi Kappa Phi. He is also received the Tony Tilman Award for service to the Southeast Section of ASEE.

Dr. Fallon's research interest is in the area of engineering education with a specific emphasis in the development of cognitive skills in students and improving their motivation in the classroom.

**Change in Engineering Education  
One Professor View  
A Look Backwards and Forwards**

**Dennis J Fallon, PE, PhD, F.ASCE, F.ASEE  
The Citadel Distinguished Professor  
Of  
Engineering Education**

**Opening Remarks**

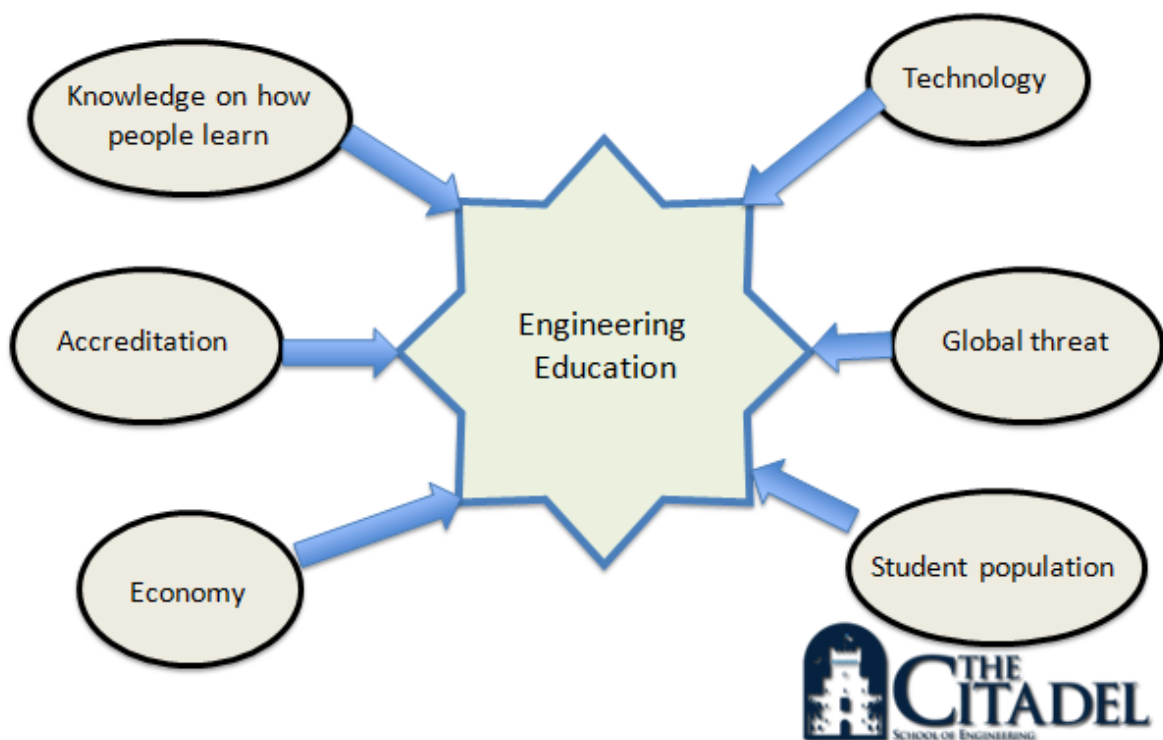
**Our Challenge**

**We are educating people to use tools and knowledge that may not even be known now  
with even more limited resources**

**May we live in exciting times**

**It was the best of times and it was the worst of times**

**Forces for Change**



### **Caveat on Discussion**

Although we will address each one of the forces for change separately, they are not separate but in fact are intertwined together. This adds to the complexity of the changes

### **Technology**

- Slide Rule my generation
- Now just about everyone has a computer
- Available computer software—push a button
- Distance Learning
- Simulation software
- Use of emailing
- Use of the Internet versus books, periodicals, journals etc.
- Use of Facebook , Twitter, You Tube etc

### **How People Learn**

- Lecture my generation—focused on the teacher
- Great strides in the fields of psychology and education has been made in understanding the learning process
- Now focus on the facilitation of learning-student centers
- Types of Learning Styles
- More use of cooperative and student teaming teaching—students teaching students
- Transform novice learners to expert learners
- Learning disabilities

### **Accreditation**

- First one done by Citadel 5 pages long
- Before 2000 basically bean counting
- Now we still count some of the beans but we also need to show assessment—takes time
- Very near future (if not now) we will have to prove that the student are really learning
- Scholarship of Teaching as well as Assessment are becoming more important
- ASEE “Creating a Culture for Scholarly and Systematic Innovation in Engineering Education.”

### **Economy**

- The Citadel in 1997 received 44% of it funding from the state
- Now it receives about 9.5%
- Faculty members are having to seek additional funding sources
- There is a trend for more accountability and justification

- Everyone is expected to do more with less
- Tuitions continuing to raise and support from gov't continue to decrease—we are in a cutting atmosphere
- State adding pressure not to increase tuitions
- *But this too shall pass*

### Student Population

- When I graduated one women in School and very few African-Americans (in fact I recall none)
- The Key Word here is Diversity
- Women make up 60% of the college population—if anything in makes good business sense.
- Now Women make up around 20%. Only around 8.5% of PE are women. Similar numbers for African-American
- We need to change the message
- In this complex society we need to have everyone at the table.

### Global Threat

- We were the center of all engineering education when I graduate
- China (as well as India) are now producing many more engineers than we do each year
- Their economy are growing at a faster rate than ours
- A project now through technology may never sleep
- However, we are still the hub of innovation and creative
- Challenge will be to provide the students opportunity to develop this skills
- In addition, I believe that we will need to develop the engineering leaders of the future—the question become how are we going to adapt our curriculums to do this???

### Bibliography

- Some Books on changes
  - Holistic Engineering Education by Grasso and Burkins
  - Educating the Engineer of 2020 by National Academy of Engineering
  - Vision for Civil Engineering in 2025 by ASCE
  - Leadership Can Be Taught by Parks
  - Liberal Education in Twenty First Century By Ollis
  - Body of Knowledge for the 21<sup>st</sup> Century by ASCE
  - Changing Practices in Evaluating Teaching by Seldin
  - Building a Scholarship of Assessment by Banta
  - How Student Learn—History, Mathematics and Science by National Research Council
  - How People Learn by National Research Council
  - Learning and Memory-An Integrated Approach by Anderson
  - New Paradigms for College Teaching by Campbell and Smith
  - Learner Centered Teaching by Weimer
  - Professional Learning Communities at Work by Defour
  - Changing the Conversation By National Academy of Engineering

**Dr. Ted E. Batchman**

Dean of the College of Engineering and Professor of Electrical Engineering and  
Biomedical Engineering Emeritus

University of Nevada, Reno

TED E. BATCHMAN is retired from the College of Engineering at the University of Nevada, Reno where he served as dean of the College for 13 years and then developed a renewable energy program for the university. He received the B.S. E. E., M. S. and Ph.D. degrees from the University of Kansas in 1962, 1963 and 1966 respectively. He worked in the aerospace industry for four years before spending 40 years in higher education. He has received a number of awards including the IEEE Millennium Medal and is a Fellow of the ASEE and IEEE.

## Reflections on Engineering Education: Past, Present, Future

### Abstract

Spending almost a half century in engineering education as an undergraduate student, graduate student, lecturer, professor, department chair and dean, has given me an opportunity to witness many changes. From the slide rule to the tablet computer, the changes have been rapid and presented a number of challenges to engineering faculty. We have been faced many questions. What are the fundamentals of engineering? How many credits does it take to educate an engineer? What are the expectations for faculty? The foundations we have established over the past years and are currently building on must serve us in the future. This paper explores how the classroom lecture has changed with technology and student expectations. Current discussions and conflicts on what engineering education should look like in the future will be discussed as well as the dilemma facing new faculty with increased expectations to achieve tenure. Cutting funds for higher education by many states has been a high priority of legislators and research funding is being cut by the federal government. So why should one go into a career in higher education? The important rewards are still the same as they were a half century ago!

### Foundations for the Future

For the past several years there was an article published on the incoming class of freshman students with the emphasis being on the many things they had not experienced that the faculty have lived through. I remember one such fact which was that the new class of students had never rolled up the window on a car by hand. This stunned me for a few minutes when I read it, but then I remember my parents buying a car in 1953 which had power windows! Many young people don't realize how things have changed over the past half-century. It is also true that many of our current faculty members have not experienced the past half-century of engineering education. They have little appreciation of the foundations of engineering education on which they must build the future. We usually only publish our successes and few of our students and faculty members understand the importance of learning from our mistakes and using these to build a strong foundation. While Henry Petroski was concerned about failures in engineering design, I believe the same applies to education. "I believe that the concept of failure – mechanical and structural failure in the context of this discussion – is central to understanding engineering, for engineering design has as its first and foremost objective the obviation of failure".<sup>1</sup> We also must learn from our past failures in engineering education. How can we justify such low graduation rates?

I will take a brief tour down memory lane before looking at where we are today and where we may be going in the future. Let's start with the tools we had as engineers. To be an engineering student, you had to have your own slide rule and drafting set. (Many of us still own them!) The slide rule was worn on the belt at all times when attending classes. Part of the drafting set was a razor blade for correcting India ink drawings. Mistakes were costly and time consuming so you learned to work very slowly and carefully. I would be remiss if I did not mention the pocket protector that we wore to enhance the image of engineers as nerds.

The curriculum required somewhere between 136 and 145 semester hours for graduation. In electrical engineering we were required to take a course called "Engineering Manufacturing Processes" which included using machine tools, casting in sand molds and using measurement instruments. We had to understand such things as tolerances, dimensions, volumes and most of all what went into manufacturing a mechanical product. Do we worry about manufacturability in most of our programs today? No! Especially not in electrical engineering. There are only 21 accredited manufacturing engineering programs in the U.S. today. Is it any wonder that most of our manufacturing is done elsewhere? As electrical engineers we had 10 credit hours in passive circuits so that we had a good understanding (foundation) in basic electrical circuits and components. That sound foundation in passive electrical circuits has been reduced to 3 credit hours or less and we

wonder why the students don't understand many of the fundamentals. We practiced solving almost every passive circuits problem the instructor could think of. Have the students been shortchanged in the fundamentals?

Looking around the classrooms there were no women students or faculty in electrical engineering except for one graduate instructor working on her Ph.D. The fact that there was one woman TA was really unusual because there were no women students or faculty in any of my engineering classes. Today, ASEE reports that 13.2 percent of the engineering faculty numbers are women.<sup>2</sup> Those few back in 1960 were the leaders for our faculty today and were laying a foundation for women in engineering. Is this good enough?

One extremely important development for engineering education was accreditation which was directed toward insuring quality in our graduates. In 1932 the Engineering Council for Professional Development (ECPD) was formed and started accrediting programs in 1936. This was "an engineering professional body dedicated to the education, accreditation, regulation and professional development of the engineering professionals and students in the U.S." There were seven professional societies involved, including what is now ASEE (Society for the Promotion of Engineering Education). This was the foundation for our current accreditation agency ABET and established many of the curricular developments in engineering based on professional society input which included a strong industrial component. The criteria were largely prescriptive with the important check sheet which counted the number of credits in mathematics, engineering science, and yes, "design." If you had the proper number of credits for each of the required ABET areas, it was felt that the students were well prepared to be engineers. There was always the question of whether faculty really knew what "design" was because many had no experience in engineering design. By the 1960's most engineering schools had the four major programs, civil, electrical, mechanical, chemical and some universities had programs in mining and metallurgical engineering, petroleum, aeronautical and nuclear engineering. There were likely more accredited programs in nuclear engineering then, than the 21 we have today. The demand for nuclear engineers waned and reactors were expensive burdens on institutions so programs were shut down.

We see today that there are 29 professional societies comprising ABET and 27 different criteria for program accreditation. Programs such as computer engineering, biomedical engineering and biological engineering were unheard of at that time. Engineering education accreditation has changed significantly over time. Today, we have to measure outcomes with industrial survey and student interviews and we are evaluated on how well we meet our "objectives." Does this new criteria insure the quality of our graduates?

In the early years of teaching, I would come from a lecture covered in chalk dust. A few colleagues were allergic to chalk and had to use white boards. Then we adopted the technology that had been used by bowling alleys and industry for a number of years-- the overhead projector. The students then had to listen to us and write down what was on the transparency. But, we could do really neat pictures, graphs and illustrations! We adopted the technology to make our work easier with very little attention given to student learning. Students often complained that it was impossible to listen to the faculty member and write down everything on the transparency. To address this complaint, some faculty members made copies of the overheads available to the students before class so that they could listen and make notes on the handouts. This was an early attempt to become student centered in our teaching techniques. There were actually faculty discussions about whether this was good pedagogy since the students would not need to listen to the lecture as closely. And what happened to the slide rule? It gave way to the calculator and caused a great deal of debate by faculties about whether calculators should be allowed in examinations. Some students might not be able to afford a calculator or what happens if the battery goes dead in the middle of the examination. Then there were the memory calculators which could store equations. Was this fair

to use on an examination? We all know how these questions were eventually answered, but were they the right answers.

Where are we today?

We have built on these foundations and engineering education in the U. S. has been a model that many other countries have tried to duplicate. ABET is now international as well as most of our engineering societies. We have been a leader over the past half century and have established the foundations for engineering programs in many countries. The changes to the accreditation criteria in 2000 focus on continuous improvement but were reluctantly accepted by some faculty. Often the comment was heard, “Don’t fix it, if it is not broke.” We were able to move past the discussion stage and early detractor’s arguments into the stage where the accreditation criteria is being evaluated and improved. The goal of improving the quality of our graduates builds strong programs for the future. We still have issues to deal with concerning public perception of quality and legislators often question the value of higher education. A quote from a recent Washington Post article illustrates this. “The failure of colleges and universities to teach basic skills, while coddling them with the plush dorms and self-directed ‘study’ is a dot-connecting exercise for Uncle Shoulda, who someday will say – in Chinese – ‘How could we have let this happen?’ One of the most damning indictments of higher education came this year with a book Academically Adrift: Limited Learning on College Campuses, by Richard Arum of New York University and Josipa Roksa of the University of Virginia. . . .but the authors’ findings are compelling. Just two examples:

- Gains in critical thinking, complex reasoning and writing skills are either ‘exceedingly small or nonexistent for a larger proportion of students’.
- Thirty-six percent of students experience no significant improvement in learning (as measured by the Collegiate Learning Assessment) over four years of higher education.”<sup>3</sup>

This type of publicity may not apply to engineering programs but is a good resource for a legislature wanting to cut budgets!

The classroom has moved from chalk and overhead transparencies to “smart classrooms” with computer capabilities and access to the internet. While we may occasionally cause student “death by PowerPoint”, we have moved to a student centered learning environment and young faculty have been very adept at using today’s technology. In some cases we have probably gone too far. I have sat in classes where students are surfing the internet, texting friends and watching videos. Faculty must set the standards and maintain control of the learning environment. Students must understand that the faculty member is not an entertainer but someone to help them learn. They must put some effort into the learning process!

What about the faculty? Have we adopted unrealistic expectations for them? We have gone from a time where faculty evaluations were based on teaching, research, publications and professional service but the only quantitative measure discussed during annual reviews was the number of publications and the expectations were relatively modest. Today, we are in an era where we are counting the quantity and quality of publications as well as research funding quality and quantity. Some faculty members argue that industrial research funding should not count as much as peer reviewed government funding. Over the years the bar has been raised considerably for young tenure track faculty. There are a number of older faculty members nearing retirement who have been excellent teachers but would not have been tenured under the current criteria. Faculty are expected to be excellent teachers (as judged by the students), have a specific number of publications each year in refereed journal publications, have research funding of several hundred thousand dollars per year, serve on several university committees as well as be involved in professional organizations and participate in K-12 outreach activities. All of this at a time when funding for faculty salaries are being cut or programs are being eliminated. Every time a new faculty member has gone through the tenure and promotion process and has raised the bar in one



area, say publications, that becomes the new standard to judge all tenure track faculty on. Are we expecting our young faculty members to be super human?

Consider also what is happening with state funding. Over the past ten years, most states have cut funding to universities to the point where they feel they are state assisted rather than state supported. On the national front, if current budget cuts are approved, NSF will suffer funding cuts which will have a direct impact on research funds for our young faculty. The combination of state funding and federal funding cuts will curtail the development of new engineering programs which have been a valuable resource for engineering education changing with the changing needs of industry and society. We should not forget our students in all of this. Unfortunately, this puts engineering educators in the same position that our industrial counterparts have been in for most of their careers. We have to go where the money is and if the majority of your resources are coming from external funding and not student tuition, where are you going to put the majority of your effort? This shortchanges the students in the quality of education they receive.

Faculty members are currently concerned about salaries, research funding and the future of their jobs. This has caused many to question their decision to go into engineering education as a profession. Would you go into higher education again if you had to start now? Most of us answer, yes, without hesitation because the real rewards for us are not monetary but are the joy of seeing a student gain a new understanding of a concept, learning to solve a problem on their own, or designing something that really works. The rewards from working with graduate students on their projects and the relationships that are developed with them are still there. The freedom to work in whatever research area we choose is still a big draw for most faculty members.

#### The Future

The future is always uncertain but will certainly involve change. Much of the change will be based on the foundations we are building today. I certainly do not claim to have that crystal ball that lets me look into the future and a number of people have tried to predict the future. One attempt using engineering principles of feedback control systems was The Limits to Growth which predicted in 1972 our current energy resource crisis among other problems we face today.<sup>4</sup> It has amazed me how we as engineering educators have focused our attention only on our own disciplines without applying our knowledge to study the broader impact of technology on society and the future of the world. Have we isolated ourselves from the rest of the world?

We need to look at the future by looking at the students. They have accepted today's communications and computing technology with open arms. They are often more comfortable communicating electronically rather than in person. I have watched many freshman students leaving a 300 seat classroom and immediately start talking on their cell phone to someone somewhere else on campus. Are they talking about the class they just left? Not likely. Think back to the days before the cell phone and we would have probably been talking about the course material, the teacher or something related to our homework. At any point we would have come to know our classmates better. Do the students know their classmates today? Is this important? I often found that when advising students having trouble with a class that they never talked with anyone in the class about the material or the homework problems. As we move to smaller and faster communication devices it obviously changes the way we interact with the students and how they interact with each other.

This first became a concern in the 1980's when we started offering video courses to graduate students in industry. Questions about how the distance students would interact with the students in the classroom were often raised. Also there was a concern that the distance students would not learn as much as the in-class students. It turned out that the course I was teaching through one-way video and two-way audio in 1987 was enriched by the industrial students. While not in the classroom, they often contributed important current and practical information to the class that I would never have had access to as an instructor. The industrial students thought the course was

great, but the in-class students had reservations about the unseen industrial students. Technology has certainly changed since then and we have the ability for two-way audio and video with these students which would enhance such a course. The students are no longer concerned about the face-to-face interactions and accept internet interactions as a preferable alternative to classroom instruction. It is obviously the preferred method of social interaction.

It seems as though we have no reservations about a new technology and assume it will be good for us. When I was teaching a large class of engineering students in Australia in the early 1970's, I was telling students about the exciting possibilities that wide band (fiber optics) communication systems would bring to their lives. One thing that was discussed was electronic mail, electronic newspapers and books. I did an informal survey and asked the students whether they would use electronic mail. Well over 90 percent of them said they would not. (I must admit that I had some reservations about it as well.) Now students can hardly wait to adopt a new technology for the simple reason of having the newest, fastest, smallest or coolest device. We must consider this as we develop new course content and new methods of instruction. It seems that we have to keep up with the students to remain relevant in their fast moving world.

Using the dynamic modeling techniques developed in reference 4, we tried to predict the future of telecommunications systems and how society would accept them. While the model was an interesting attempt at engineering prediction, we completely missed the advent of the cell phone and the rapid acceptance of this pervasive and invasive technology.<sup>5</sup> As faculty we must be attuned to new technology and how we can use it to improve our teaching. I cannot attempt to predict the future of communications technology, but I know it will come and will be adopted rapidly by the younger generations of students. This is a new challenge for our faculty.

Another thing that we must consider in the future is the financial resources available to higher education. Can we afford the physical classrooms on our campuses or will we have to become more efficient through communications technology? How much research funding will be available to support our expensive research programs? From everything I read about the financial future, it is uncertain at best and if Congress continues to be "dysfunctional," we may have a period of five to seven years of budget cutting.<sup>6</sup> There is a wonderful little book by David Boren, president of the University of Oklahoma that I recommend reading.<sup>7</sup> "America is in trouble because its people are losing faith in the country's future. We have grown cynical of our political system and dubious of its ability to effect meaningful change." The attitude of society toward our government's inability to solve the deficit problem may affect the number of students entering our programs and resources for teaching and research. While this may seem very negative, our past has shown that we have a strong foundation to build on and we will change to meet the challenges. The most important rewards for faculty will still be there.

It is quite appropriate that we are meeting in Philadelphia, the birthplace of our democratic form of government, and discussing the future of engineering education. We need to develop a strong alliance among engineering educators such that we educate the public on the importance of engineering education to the future of our country and society. Companies are built on an educated workforce and new innovations come from our students when they enter the workforce. Most leaders in the area of economic development realize that companies locate where there are adequate technical, business and engineering employees. It is up to us to provide the fuel for economic development.

How will the curriculum change to meet the needs of our future society? The current discussions about a five year first professional degree, while having merit, may well be overshadowed by state legislators pushing for shorter degree programs (120 hours) and greater retention of entering students. If such occurs, we must work to maintain the quality of our programs in the face of budget constraints. While 120 credit hours may be sufficient for a degree in general studies or liberal arts, it becomes problematic for engineering programs to squeeze everything into that

number of credits. What can we cut from the curriculum and still provide our students with the quality foundation upon which to build their engineering careers?

We also need to educate people that we are becoming a much more technical society and need to have some basic understanding of technology. “Though ours is an age of high technology, the essence of what engineering is and what engineers do is not common knowledge. Even the most elementary of principles upon which great bridges, jumbo jets, or super computers are built are alien concepts to many. This is so in part because engineering as a human endeavor is not yet integrated into our culture and intellectual tradition. And while educators are currently wrestling with the problem of introducing technology into conventional academic curricula, thus better preparing today’s students for life in a world increasingly technological, there is as yet no consensus as to how technological literacy can best be achieved.”<sup>1</sup>

What are the facts on nuclear energy? What is global warming and how much is generated by automobiles, power plants and our use of energy in our homes and industries? What about the third world countries which are struggling to gain some of the luxuries that this energy has provided to us? My last two years of teaching provided me with the unique opportunity of working with a colleague in political science to teach an introductory course in Renewable Energy which was open to students of all disciplines.<sup>8</sup> This course provided me with a new appreciation of the importance of building a foundation of understanding for the students based on three legs of a stool; the technical, the policy and the economic. How many of your courses do you try to tie all of these together for the students? It is easy to discuss the technical issues of renewable energy with our engineering students but much more difficult to get a political science student to understand even the first two laws of thermodynamics. And the engineering students have just as much difficulty understanding policy concepts such as “public good” or the energy policy act of 1992. Can we afford to isolate ourselves from our colleagues on campus and turn out graduates with a very narrow perspective? While technology may drive many of the changes in the future, public policy, regulations and subsidies may well determine which technologies are successful. Do the people making the policy decisions understand even a small amount of the technology? Is it important that they understand the technology issues or should energy policy be based on subsidies to certain states because they have an abundance of corn, natural gas or coal?

A major driver for engineering education for the future will likely be the number of students adequately prepared in science and mathematics when entering the university. Most of our state schools have a large number of freshman remedial courses. The majority of students enrolling in remedial math and science courses are not interested in engineering but those who are interested seldom make it to our courses because they do not develop the strong math skills or they realize they may take several years longer to get their degree and they cannot afford it. We have made great strides in working with the K-12 system to interest more students at an early age in science, technology, engineering and math courses, but we are still behind. Will funding be cut from such STEM programs as our resources are cut? We must realize that these students are our future.

It seems to me that the demands on faculty will increase in the future. They must be excellent teachers using the most modern communications technology. They need to attract significant amounts of research funding, they need to publish extensively and they need to help develop the K-12 pipeline into an engineering career. In addition, they need to insure that the curriculum is up-to-date and meets the needs of new and developing industries.

Will the rewards still be there for our young faculty members? Can we maintain the tenure and promotion bar at a level that is reasonable to attain or will we lose too many of our good teachers? We also must look at opportunities to use retired engineers from industry to teach some of our courses and laboratories. Their experience is valuable to our students, but we must treat these instructors with the respect they deserve. I have seen too often that such faculty members are viewed as second class citizens by our tenure track faculty. They are also often underpaid for the

amount of work involved. With budget cutting we often lose our temporary faculty funds and have to load our faculty with additional courses.

So what does the future hold for us in engineering education? Engineering education programs have a number of strengths based on our past focus on quality. We still have a number of weaknesses that we need to address such as requirements placed on faculty for tenure and promotion. New opportunities to build on a sound foundation of quality are certainly in our future and we have to face the threats of budget cutting which could destroy the foundation we have built.

1. To Engineer is Human, Henry Petroski, Vintage Books, 1992
2. ASEE DataBytes, Faculty Demographics, September 29, 2011
3. The Washington Post, September 30, 2011, "Our unprepared graduates" by Kathleen Parker
4. The Limits to Growth, Donella H. Meadows, Dennis L. Meadows, Jorgen Randers and William W. Behrens III, Universe Books, 1972
5. T.E. Batchman and A. I. Wearing, "Application of Dynamic Modeling to the Social Consequences of Telecommunications," IEEE Transaction on Systems, Man and Cybernetics, Vol. SMC-6, 9,(Sept. 1976) pp. 612-622
6. AP story, October 1, 2011, "Analysis: Congress' dysfunction long in the making"
7. A Letter to America, David Boren, University of Oklahoma Press, 2001
8. Christopher A. Simon, Alternative Energy, Bowman and Littlefield, 2007

Department of Engineering  
301 Platt Boulevard  
Claremont, CA 91711-5990  
Office: 909.621.8853  
Facsimile: 909.621.8967  
Email: [clive\\_dym@hmc.edu](mailto:clive_dym@hmc.edu)



CLIVE L. DYM is Fletcher Jones Professor of Engineering Design and Director of the Center for Design Education at Harvey Mudd College. His primary interests are in engineering design and structural mechanics. After receiving the PhD from Stanford University, Dr. Dym held appointments at the University at Buffalo; the Institute for Defense Analyses; Carnegie Mellon University; Bolt, Beranek and Newman; and the University of Massachusetts at Amherst. He was also head of his department at UMass (1977-85) and chair of his department at Harvey Mudd (1999-2002). Dr. Dym has held visiting appointments at the TECHNION-Israel Institute of Technology, the Institute for Sound and Vibration Research at Southampton, Stanford, Xerox PARC, Carnegie Mellon, Northwestern, USC and the Singapore University of Technology and Design. He has authored or coauthored more than 90 refereed journal articles, was Founding Editor of the journal *Artificial Intelligence for Engineering Design, Analysis, and Manufacturing*, and has served on the editorial boards of several other journals, including the ASME's *Journal of Mechanical Design*.

Dr. Dym is a Fellow of the Acoustical Society of America, the American Society of Mechanical Engineers, the American Society of Civil Engineers and the American Society for Engineering Education, and is a Member of the American Academy of Mechanics. Dr. Dym's awards include:

- the *Walter L. Huber Research Prize* (ASCE, 1980),
- the *Western Electric Fund Award* (ASEE, 1983),
- the *Boeing Outstanding Educator Award* (first runner-up, 2001),
- the *Fred Merryfield Design Award* (ASEE, 2002),
- the *Joel and Ruth Spira Outstanding Design Educator Award* (ASME, 2004), and
- the *Archie Higdon Distinguished Educator Award* (Mechanics Division, ASEE, 2006).

#### **BOOKS WRITTEN**

1. Clive L. Dym and Irving H. Shames, *Solid Mechanics: A Variational Approach*, McGraw-Hill Book Company, New York, 1973. (Reprinted as International Student Edition, McGraw-Hill Kogakusha, Ltd., 1975; Japanese translation published by Brain Book Company, Tokyo, 1977.)
2. Clive L. Dym, *Introduction to the Theory of Shells*, Pergamon Press, Oxford, 1974. (Updated edition, Hemisphere Publishing, New York, 1990.)
3. Clive L. Dym, *Stability Theory and Its Applications to Structural Mechanics*, Noordhoff International Publishing Company, Leyden, The Netherlands, 1974. (Republished by Dover Publications, New York, 2002.)
4. Irving H. Shames and Clive L. Dym, *Energy and Finite Element Methods in Structural Mechanics*, Hemisphere Publishing, New York, 1985. (SI Units Edition, Taylor & Francis,

New York, 1991.)

5. Clive L. Dym and Raymond E. Levitt, *Knowledge-Based Systems in Engineering*, McGraw-Hill Book Company, New York, 1991.
6. Clive L. Dym, *Engineering Design: A Synthesis of Views*, Cambridge University Press, New York, 1994.
7. Clive L. Dym, *Structural Modeling and Analysis*, Cambridge University Press, New York, 1997.
8. Clive L. Dym and Patrick Little, *Engineering Design: A Project-Based Introduction*, John Wiley & Sons, New York, 1999 (1st Edition), 2004 (2nd Edition), 2008 (3rd Edition, with E. J. Orwin and R. E. Spjut); Spanish translation, Limusa Wiley, Balderas, Mexico, 2002; Korean translation, Info-Tech Corea, Seoul, South Korea, 2008; Portugese translation Artmed Editora, S.A., Porto Alegre RS, Brazil, 2010.
9. Philip D. Cha, James J. Rosenberg, and Clive L. Dym, *Fundamentals of Modeling and Analyzing Engineering Systems*, Cambridge University Press, New York, 2000.
10. Clive L. Dym, *Principles of Mathematical Modeling*, 2nd Edition, Elsevier Academic Press, New York, 2004. (First edition, 1980, co-authored by Elizabeth S. Ivey.)
11. Jennifer Stroud Rossman and Clive L. Dym, *An Introduction to Engineering Mechanics: A Continuum Approach*, CRC Press, Boca Raton, Florida, 2008.
12. Clive L. Dym and Harry E. Williams, *Analytical Estimates of Structural Behavior*, CRC Press, Boca Raton, Florida, in press for 2012 publication.
13. Clive L. Dym and David C. Brown, *Engineering Design: Representation and Reasoning*, Cambridge University Press, New York, in press for 2012 publication.

#### **SELECTED REFEREED JOURNAL ARTICLES**

1. C. L. Dym, "Teaching Design to Freshmen: Style and Content," *Journal of Engineering Education*, 83 (4), 303-310, October 1994.
2. C. L. Dym, "Learning Engineering: Design, Languages, and Experiences," *Journal of Engineering Education*, 88 (2), 145-148, April 1999.
3. C. L. Dym, W. H. Wood and M. J. Scott, "Rank Ordering Engineering Designs: Pairwise Comparison Charts and Borda Counts," *Research in Engineering Design*, 13, 236-242, 2002.
4. C. L. Dym, "Social Dimensions of Engineering Design . . . An Engineer's Perspective," *International Journal of Engineering Education*, 19 (1), 3-5, 2003.
5. C. L. Dym and H. E. Williams, "On the Analysis of Small Displacements of Truss Joints," *International Journal of Mechanical Engineering Education*, 31 (2), 132-140, 2003.
6. C. L. Dym, A. M. Agogino, O. Eris, D. D. Frey and L. J. Leifer, "Engineering Design Thinking, Teaching and Learning," *Journal of Engineering Education*, 94 (1), 103-120, January 2005.
7. H. E. Williams and C. L. Dym, "Using Rotations to Obtain Compatibility Equations for Statically Indeterminate Trusses," *Journal of Structural Engineering*, 131 (2), 353-358, February 2005.
8. C. L. Dym, "Engineering Design: So Much to Learn," *International Journal of Engineering Education*, 22 (3), 422-428, 2006.
9. D. D. Frey and C. L. Dym, "Validation of Design Methods and Theories: Lessons from Medicine," *Research in Engineering Design*, 17, 45-57, 2006.

10. C. L. Dym and H. E. Williams, "Exploring Physical Intuition in Elementary Pressure Vessels," *International Journal of Mechanical Engineering Education*, 35 (2), 108–113, April 2007.
11. C. L. Dym and H. E. Williams, "Estimating Fundamental Frequencies of Tall Buildings," *Journal of Structural Engineering*, 133 (10), 1479–1483, October 2007.
12. C. L. Dym, "Consistent Derivations of Spring Rates for Helical Springs," *Journal of Mechanical Design*, 131 (7), 071004-1-5, July 2009.
13. C. L. Dym, "Sustainability: Affirming Engineering Values," *International Journal of Engineering Education*, 26 (2), 240–246, February 2010.
14. C. L. Dym, "Extending Castigliano's Second Theorem to Model the Behavior of Coupled Systems," *Journal of Applied Mechanics*, 77 (6), 061005-1-6, November 2010.
15. C. L. Dym and H. E. Williams, "Stress and Displacement Estimates for Arches," *Journal of Structural Engineering*, 137 (1), 49–58, January 2011.
16. C. L. Dym, "End-Loaded Shallow Curved Beams," *Journal of Structural Engineering*, 137 (7), 782–784, July 2011.

# Design for Sustainability: An Ethical Constraint

Clive L. Dym  
Fletcher Jones Professor of Engineering Design  
HARVEY MUDD COLLEGE  
Email: clive\_dym@hmc.edu

## A Developing World-Wide “Perfect Storm” ? (Some Global Challenges for the 21<sup>st</sup> Century)

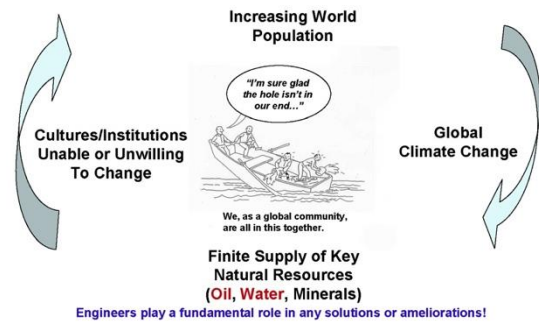


Fig. 1 John McMaster's Perfect Storm [2]

## Abstract

This paper is intended as reminder to engineering and design educators that issues of sustainability are inherent in and central to the ethical obligations of both practicing engineers and teachers of engineering.

### 1. Introduction

Until relatively recently, a global focus indicated a focus on global trade and economics and their consequences. Now, early in the 21st century, a global focus demands global recognition of an increasing global threat to the very existence of the environment within which civilization developed.

Some of the signs that indicate how rapidly and thoroughly the environment is changing are highlighted in the next section, after which several of the responses of the

engineering enterprise to these environmental changes are described. Finally, some concluding suggestions are offered [1].

### 2. Environmental Drivers

The starting point is a reiteration (and recycling!) of a warning provided by the late John H. McMaster. He identified a *perfect storm* of forces that reflect major changes in the environment. McMaster's perfect storm identifies the following four major components that are also depicted in Fig. 1 [2].

- *global warming (and the role that human activity plays in fostering it)*, which is now, apparently (and finally?) accepted and understood as the major—and in some sense perhaps *the*—environmental challenge facing the world;
- an increasing awareness of the *finite supply of natural resources* such as oil, water (especially potable water) and a



- variety of minerals (including soil); and
- a *rapidly growing world population* and its concomitant demographics, as a result of which many countries and regions are faced with disproportionately large populations of young people who need not only food and shelter, but also education, and for whom jobs must be provided in economies that are not growing nearly fast enough;
- that *many of the world's institutions and cultures are either unable or unwilling to change* or to otherwise respond positively to the other three converging trends of this perfect storm.

Now, there are many indicators that point to changes in the environments in which engineers (in particular) live, are educated, and practice. Some indicators reflect the vast growth of knowledge, which as with so many other matters these days itself often seems to easily outstrip Gordon Moore's famous heuristic about the doubling of computer processing capability. Sustainable design inexorably involves all four of the trends in McMasters' perfect storm (deteriorating climate, scarce resources, increasing population and cultural inertia), and there are vast amounts of data available Engineering practice, whether traditional or sustainable, must account for the fact that inputs to engineering processes and manufacturing are increasingly expensive because of the increasing scarcity of key natural resources. For example [5], during the time period 2004–08, the prices of oil and natural gas *doubled*, while the price of industrial electricity *tripled*. And the future is not likely to be any more forgiving than the recent past.

Consider the data displayed in Table 1 wherein current US sources of electrical power and their anticipated 2016 costs are displayed. The data show that the US is

on each. For the present, however, it seemed interesting to simply take a snapshot of a few news items that touched only on the first two aspects of the perfect storm (i.e., deteriorating climate and scarce resources) and that crossed the author's desk and screen over the course of a few days. After all, this is part of the information overload to which everyone is subjected, even as everyday concerns make it rather difficult to attend to the surrounding environment.

There are still those who make the (sometimes interesting) case that the threat of global warming and environmental deterioration is exaggerated [3], with perhaps the most persuasive argument (to this author, at least) being that the scientific consensus has been woefully wrong in the very recent past. That is, in the 1970s it was predicted that a major cooling of the planet was inevitable, and in the 1980s a shortage of renewable natural resources was predicted because of anticipated population increases. Neither of these events has occurred, the argument goes, so one should not believe today's scientific consensus. Yet as information continues to accumulate, it is ever harder to ignore that information and dismiss the consensus about what the best available science is saying right now [1, 4]. highly dependent on coal, and markedly less so on nuclear power and natural gas. The data also clearly show that so-called alternative sources of energy are not likely to be very cheap nor are some of them widely acceptable. For example, nuclear power generation is the cheapest, yet it still remains controversial and a source of fear for many. Further, there have already been widely publicized instances of NIMBYism with regard to various wind generation projects, and ecological and aesthetic concerns are also being expressed about large-scale solar projects.

---

Table 1 Future Electricity Costs (Adapted from [6])

Energy Source	Current Use (electrical production, 10 <sup>12</sup> BTU (%))	2016 Cost (per megawatt hour, 2007\$)
Nuclear	8,415 (20)	\$104.80
Hydroelectric	2,463 (6)	\$112.80
Biomass	824 (2)	\$113.00
Natural gas	7,716 (19)	\$114.80
Wind	319 (1)	\$115.50
Coal	20,990 (51)	\$120.40
Oil	715 (2)	NA
Solar (photovoltaic)	6	\$385.40
Solar (thermal)	6	\$257.50

It is also interesting that the above US-centered view is rendered almost meaningless if even just a few global aspects are included. For example, the Department of Homeland Security’s representative on the national Science and Technology Council recently said that ([5], emphasis added), “There are *six* cars for every 1,000 people in China and more than *300* cars for every 1,000 people in the United states. When the Chinese increase that to *eight* cars per 1,000, *they will consume as much gasoline as the United States today.*” Imagine what that means for the economies of the US and the rest of the world. Still further, it is hardly a secret that China has worked very hard over the last decade to lock up mineral resources, from copper to oil, in long-term contracts.

Fig. 2 displays a recent article in the *Los Angeles Times* [7] that described a brand new commercial greenhouse used to grow tomatoes. Among its attributes, the greenhouse “generates its own renewable power . . . hoards rainwater . . . hosts its own bumblebees for pollination . . . and requires a fraction of the chemicals used in neighboring fields to coax plants to produce like champions.” The greenhouse achieves

this by bounding a “closed, sustainable environment” that less than one-fifth of the water than conventional field irrigation and cultivation would dictate. The greenhouse was built near Camarillo, California, by Houweling Nurseries, a Canadian farming company. The company’s president, Casey Houweling, said that, “We believe this is the first greenhouse in the world that is energy neutral.” It may be more than coincidence that Houweling is himself of Dutch extraction.

Why more than coincidence? A 1995 article in the *Harvard Business Review* [8] argued that there is an inherent logic that couples environmental and resource concerns to innovation and good design and engineering in a very positive way. Early in the days of the environmental movement it was routinely argued that ecological concerns were in an adversarial trade-off with economic growth because the environmental benefits were seen to be *social* (or society’s) benefits, whereas the costs of cleaning up or preventing pollution were *private* costs that would be borne by industry. However, the argument goes, it should be recognized that pollution represents an inefficient use of resources



Fig. 2 Canadian-American-Dutch Farming [7]

that typically results from excess or wasted manufacturing by-products. Good design and innovation that is aimed at reducing these polluting by-products results in *resource productivity* that enhances profits [8].

And what does this have to do with Casey Houweling being Dutch? Well, perhaps nothing, but it is also the case that, as the *Harvard Business Review* article also points out [8], it was the Dutch who long ago recognized that it had severe environmental problems in cultivating its renown tulips: “Intense cultivation of flowers in small areas was contaminating the soil and groundwater with pesticides, herbicides, and fertilizers. Facing increasingly strict regulation . . . The Dutch understood that the only effective way . . . develop a closed-loop system . . . flowers now grow in water and rock wool . . . reducing fertilizer . . . delivered in water that circulates and is reused.” That is, the Dutch developed tightly monitored closed-loop systems that dramatically reduced both the environmental impact and the cost. These closed-loop systems also increased the

quality of the flowers grown and enhanced Holland’s competitiveness in the international flower market.

It is important to point out here that while some key resources are clearly irreplaceable and expensive in terms beyond simple financial reckoning, that is less the case for the potential shortages of minerals. In fact, the consequences of mineral shortages have typically been sorted out in the marketplace by demand-driven pricing—e.g., people drive less and/or buy more efficient autos when gas prices go up—and by technical innovation—e.g., wireless communication is clearly supplanting extensive grids of telephone land lines made of copper.

(Correctly predicting future resources is far from easy; a world-famous bet by a renowned population biologist is described in [3].) By way of contrast, when water and soil are lost, two very scarce resources are absolutely lost. And this may also be said about global biodiversity, tropical rain forests, and many types of fish across the oceans [9, 10].

As noted above, on any given day there are dozens of news stories about environmental (and, these days particularly) economic degradation and increasing numbers of stories about design and engineering efforts aimed at substantially mitigating, if not virtually eliminating, pollution and waste. Indeed, a few more examples will be cited in the next section as the engineering profession’s response is discussed. It seems safe enough to say that the need for better design and better engineering is real, notwithstanding the doubting Thomases [9]. In fact, even if one were to embrace the doubters’ skepticism, it would seem like good engineering practice to design for sustainability in the spirit of Pascal’s famous wager. That is, in its starkest terms, can one afford not to design for sustainability? Even if current models of how much sea levels would rise if Antarctica’s massive western ice sheets fully disintegrated as a result of global

warming are imperfect models, can one put such (varying) predictions aside? What if the predictors of global catastrophe are right?

### 3. Engineering Values

What should designers, engineers and educators be doing in the face of this continuing avalanche of news and data about environmental deterioration? After all, there's no doubt that the US engineering enterprise, and particularly its education effort, have been both affected by and players in many of the major issues of the times. For examples, once operations research and applied physics had demonstrated their utility in fighting World War II, engineering education and research was markedly influenced—if not steered—by defense considerations. Similarly, both the space race (starting in the 1960s) and environmental concerns (beginning in the 1970s) became major players in engineering academia. So, will climate and sustainability issues become similarly significant? And will that significant presence be felt only in the educational establishment, or will it become so in practice as well?

It seems pretty clear—at least to this observer—that sustainability has become a matter of importance, although some of its influences may not be readily observable or easily identified or ascribed. In academia, for example, it is already very clear that college and universities are taken on the issues of sustainability in the ways that they operate, both short term with such innovations as “tray-less cafeterias,” and long term with LEED certification now being a prominent part of facility planning and design.

What is truly interesting about these developments is that they seem to be very much student driven, as opposed to being driven by faculty or academic administrators. By way contrast, the environmental movement that emerged in the 1970s and which led to many great changes in academic offerings—just think of

how commonplace it has become for departments of civil engineering to become departments of civil *and environmental* engineering—was as much driven by younger faculty as it was by student interests. Now, however, it seems that the motivation is more often comes from students who evince concern about ecological fragility, the scarcity of precious resources such as clean air and water, and the general health of the planet.

The attitudes of engineers in industry are rather similar to those of their student counterparts, according to a recent survey of mechanical engineers on sustainability [11]. Although by slightly different margins, both professionals and students considered that the most important sustainable technologies are (in decreasing order of importance): designs that use less energy or reduce emissions, manufacturing processes that use less energy and natural resources, designs that use materials that are renewable/recyclable/recycled, and manufacturing processes that produce less pollution or greenhouse gases. On the other hand, working engineers felt that their organizations are most likely to use sustainable methods to make cost-competitive new products or to reduce the costs of existing products, that is, cost appears to be the driving factor. At the same time, these working engineers felt that the factors most likely to affect their organization's use are (again in decreasing order) regulatory requirements, rising energy costs, clients' demands, with the ability to gain a market advantage and long-term investment return being tied for fourth/fifth place.

One widespread area of concern about design for sustainability is a dearth of information about many of the issues involved, with their seeming to be a clear need for more codes and more standardized methodologies for design and evaluation. One engineer cited in the survey [11] noted that, “Perhaps the biggest hurdle is the lack of a clear ‘road map’ to effective sustainable

practices. As there is no single technique or practice, each industry or even location must figure out on its own what sustainable practices it can effectively implement.” Notwithstanding this expressed concern for codes and practices and other sorts of engineering information, engineers are in fact achieving significant sustainability success stories. Some of these stories seem like nothing more than (uncommon!) common sense, as in the desire to reduce or even eliminate waste. (Recall the earlier discussion of waste and consequent pollution as a sign of inefficiency that ought to be addressed by improving resource productivity.) For example, the parent company of Subaru of Indiana Automotive Inc., Fuji Heavy Industry Ltd., told Subaru in 2002 that it wanted them to generate no landfill waste by 2006 [12]. In fact, Subaru achieved this goal by May 2004 by initially recycling soda cans, using recycled paper and disposing of plastics in color-coded recycling bins. Over time—and not much time at that—this recycling mentality was extended to include steel, wooden shipping pallets, cardboard, plastics of all sorts, and Styrofoam. Thus, while Subaru generated 459 lb of waste for each assembled automobile in 2000, it got down to 251 lb per car by 2007, of which 190 lb was steel that was easily recycled. Some of their unused packing materials are returned to Japan in otherwise unfilled shipping containers for re-use, while other waste materials are either sold (e.g., plastics, steel) or used for power generation (unrecyclable paper).

The focus of the foregoing example appears, at a superficial level, to be simply about reducing waste. However, it is also about examining the processes by which waste materials are produced and the by which they are wasted. Indeed, many of the advances in sustainability will be made by the detailed examination of processes using sophisticated technical understanding and achievement. For example, some 2 billion gallons of metalworking fluids were used to

cool and lubricate metals in the US in 2000, and it costs about \$1 /gal to buy, maintain, recycle and dispose of such metalworking fluids [12]. It turned out that a mechanical engineer deconstructed the lubrication process and developed a new process that eliminated the real problem, the water required for conventional metalworking lubrication. This new process uses supercritical carbon dioxide (in place of water) to provide the minute amount of oil used to provide machining lubricity and to then dissolve and eliminate the oil. With this new process water is no longer a problem because oil is now used at a rate of only 5 ml/hr, at which rate one would have to machine metals for 30–60 24-hour days to produce the same waste with conventional techniques. And there is no shortage of further instances of sustainable process design [12].

It should be that the examples cited above involved corporate desires to reduce costs and to provide management leadership on sustainable design. Of course, both of these elements were cited as important in the survey of mechanical engineers mentioned above [11]. Cost issues are inherent in so many ways. For example, the installation of a new metalworking technology such as that just outlined most likely requires capital investment, in which case decisions are required about the requisite investment and about its allocation on the company's books and its distribution among its cost centers. In addition, of course, there is the longstanding concern about balancing costs that are easily identified as private with benefits that may be social, private, or a mixture, depending on who is assigning or apportioning those benefits. Of course, if codes or regulations require certain compliances, then the benefits must then be accounted for as the those resulting from being able to market and sell an appropriately compliant product—and there is mounting evidence that there are certain demographics that are more willing

to spend more to buy products that are not environmentally damaging. Leadership at sufficiently high levels is especially important to ensure that problems—and potential solutions—not be confined to silos within a company. For example, soy-based inks are renewable, biodegradable, and less toxic than conventional inks, yet they also can make shop floors slippery. Thus, safety compliance (and perhaps the human resources) issues have to be addressed, as well those of printing efficacy, which means that a broad spectrum of people within the company need to be involved. Similarly, in some instances corporate leadership may be required to ensure that sustainability concerns are properly addressed by companies or organizations outside of the company, such as its suppliers. For example, claims that a complex product has been produced with an optimized carbon footprint can only be supported if manufacturers' suppliers of materials and components also adhere to corresponding sustainability goals, which is likely to happen only if there are appropriate relationships between the manufacturer and the members of its supply chain. Interestingly enough, in addition to appropriate relationships with suppliers, such approaches require standardized methodologies and measures for assessing performance and compliance, which is one instance of a generic point made earlier.

Now, while sustainability is increasingly seen as a desirable and “hot” topic in engineering design, practice, research and education, it is also worth noting that sustainability concerns are entirely consistent with longstanding obligations laid out in the codes of ethics laid out by some professional societies. For example, the American Society of Civil Engineers (ASCE) has since 1996 explicitly recognized sustainability as central tenet of its first fundamental canon (viz., Fig. 3). It is interesting to note that the American Society of Mechanical Engineers (ASME) has within its code of ethics the same fundamental principle and the same fundamental canon as does the ASCE, it does not specifically address (or even mention) sustainability here (viz., Fig. 4). The Institute of Electrical and Electronic Engineers (IEEE) does not mention sustainability and, by way of contrast with the ASCE and the ASME, rather than “hold paramount the safety, health and welfare of the public,” it instead insists only that engineers should make “to accept responsibility in making decisions consistent with the safety, health and welfare of the public.” Perhaps this difference in wording is unimportant, but perhaps it is.

---

Excerpts of the American Society of Civil Engineers' Code of Ethics

**Fundamental Principle**

Engineers uphold and advance the integrity, honor and dignity of the engineering profession by:

1. using their knowledge and skill for the enhancement of human welfare and the environment;

**Fundamental Canon**

1. Engineers shall hold paramount the safety, health and welfare of the public and shall strive to comply with the principles of *Sustainable Development* in the performance of their professional duties.

*Sustainable Development* was defined (by the ASCE Board of Direction in November 1996) as “the challenge of meeting human needs for natural resources, industrial products, energy, food, transportation, shelter, and effective waste management while conserving and protecting environmental quality and the natural resource base essential for future development.”

Fig. 3 Excerpts of the Code of Ethics, American Society of Civil Engineers (2006)

---

---

Excerpts from the Institute of Electronics and Electrical Engineers' Code of Ethics

We, the members of the IEEE, in recognition of the importance of our technologies in affecting the quality of life throughout the world, and in accepting a personal obligation to our profession, its members and the communities we serve, do hereby commit ourselves to the highest ethical and professional conduct and agree:

1. to accept responsibility in making decisions consistent with the safety, health and welfare of the public, and to disclose promptly factors that might endanger the public or the environment;

Fig. 4 Excerpts of the Code of Ethics, Institute of Electronics and Electrical Engineers (2006)

---

In fact, it seems a fairly good argument that engineers and designers do have a special burden to work toward sustainability because their very methodology enables them to ascertain costs and benefits, both public and private. It is true that this position may require some “readjustment” of the frameworks and limits within which engineers do their work. But in the same way that industry learned to turn environmental challenges into

economic opportunities engineers can and should routinely view their cost and benefit calculations within the broadest possible parameters: DuPont and imperial chemical Industries with their development of chlorofluorocarbon (CFC) substitutes [12]. Thus, they should routinely work to avoid waste and pollution inefficiencies, while at the same time working to improve resource productivity by minimizing the use of scarce, irreplaceable, expensive resources.

#### 4. Conclusions

In the words of one well-known heuristic [13], engineers should, “Always give an answer.” And in this context, any and all answers should be cast in the broadest possible terms. That is, in the context of unsustainable ecological damage and irretrievable loss of essential resources, engineering educators should perhaps follow the lead of their students and erase—or at least work energetically to minimize—the distinction between private benefits and social benefits. Further, while some of the remarks presented above may be in the vein of preaching to the choir about issues of teaching design, it is also true that the many benefits associated with emphasizing sustainability in teaching design also address many of the primary goals of engineering education. Thus, the importance of both design and design for sustainability to engineering education cannot be overemphasized. Perhaps, as a colleague of mine recently suggested [14], the emergence of sustainability as a major driver of engineering education and research perhaps represents the mainstreaming of environmentalism. It would be nice to think that is uniformly true across all engineering disciplines, as well as across the practice of engineering and design. To the extent that it is not, design and engineering educators should also work energetically to make it so. One interesting way to do that might be to follow a suggestion made at Mudd Design Workshop VII in May 2009, namely, “design for sustainability” should be treated as an ever present *constraint* rather than as an occasional objective [15].

#### Acknowledgments

This paper is an adaptation of an article that appeared in the *International Journal of Engineering Education*, Vol. 26, No. 2, 2010.

It is a pleasure to acknowledge two of my Harvey Mudd College colleagues for thoughtful conversations and useful suggestions: Professors Paul Steinberg, of the Department of Humanities, Social Sciences and the Arts, and Pat Little, of the Department of Engineering.

#### References

- [1] B. Bates, Z. W. Kundzewicz, S. Wu and J. Palutikof (Editors), *Climate Change and Water*, Technical Paper of the Intergovernmental Panel on Climate Change, IPCC Secretariat, Geneva, June 2008.
- [2] J. H. McMasters, “A Paleoaerodynamicist’s Reflections—A Perspective on Airplane Design and the Biomechanics of Flight,” *Leonardo Times*, 10 (3), 24–64, September 2006.
- [3] George F. Will, “Dark Green Doomsayers,” *The Washington Post*, 15 February 2009.
- [4] N. Oreskes, “The Scientific Consensus on Climate Change,” *Science*, Vol. 306, p. 1686, 3 December 2004.
- [5] A. S. Brown, “The Many Shades of Green,” *Mechanical Engineering*, pp. 22–29, January



- 2009.
- [6] P. Basken, "Stimulus Law Revs Up Research on Energy," *The Chronicle of Higher Education*, pp. A1 and A8–A9, 8 May 2009.
  - [7] J. Hirsch, "Planting a Farming Revolution," *Los Angeles Times*, pp. B1–B2, 14 May 2009.
  - [8] M. E. Porter and C. van der Linde, "Green and Competitive," *Harvard Business Review*, pp. 120–134, September–October 1995.
  - [9] J. Bongaarts, "Policy Options in the Developing World," *Science*, Vol. 263, pp. 771–776, 11 February 1991.
  - [10] P. M. Vitousek, H. A. Mooney, J. Lubchenko and J. M. Melillo, "Human Domination of Earth's Ecosystems," *Science*, Vol. 277, pp. 494–499, 25 July 1997.
  - [11] A. S. Brown, "Conflict on the Green," *Mechanical Engineering*, pp. 42–45, March 2009.
  - [12] A. S. Brown, "The Many Shades of Green," *Mechanical Engineering*, pp. 22–29, January 2009.
  - [13] B. V. Koen, *Discussion of the Method*, Oxford University Press, New York, 2003.
  - [14] P. F. Steinberg, Personal communication, 15 May 2009.
  - [15] B. Linder, "Achieving a Sustainable Environmental Perspective," *International Journal of Engineering Education*, Vol. 26, No. 2, pp. 293–296, 2010.

**Ramesh K . Agarwal**  
**Mechanical Engineering & Materials Science**  
**Washington University in St. Louis**

*ASEE Mid-Atlantic Fall Conference 2011*  
*Temple University, PA, 29 October 2011*

**Introducing Sustainability d**  
**in Engineering Education**

**Sustainable Product Design**  
**in all Disciplines of Engineering**  
**(Keynote)**

### **Bio of the Presenter**



## **Bio of the Presenter**



Professor Ramesh Agarwal is the William Palm Professor of Engineering and the director of Aerospace Engineering Program and Aerospace Research and Education Center at Washington University in St. Louis. From 1994 to 2001, he was the Sam Bloomfield Distinguished Professor and Executive Director of the National Institute for Aviation

Research at Wichita State University in Kansas. From 1978 to 1994, he worked in various scientific and managerial positions at McDonnell Douglas Research Laboratories in St. Louis. He became the Program Director and McDonnell Douglas Fellow in 1990. Dr. Agarwal received Ph.D in Aeronautical Sciences from Stanford University in 1975, M.S. in Aeronautical Engineering from the University of Minnesota in 1969 and B.S. in Mechanical Engineering from Indian Institute of Technology, Kharagpur, India in 1968. Over a period of 35 years, Professor Agarwal has worked in Computational Fluid Dynamics (CFD), renewable energy systems and nanotechnology. He is the author and coauthor of over 300 publications and serves on the editorial board of fifteen journals. He is a Fellow of fifteen societies including ASME, AIAA, IEEE and ASEE. He has received many prestigious honors and awards.



# Sustaining the Future



**Gro Harlem Brundtland**

## **Sustainable Development:**

“Development that meets the needs of the present without compromising the ability of future generations to meet their own needs.”

**The Brundtland Report: *Our Common Future*, 1987, World Commission on Environment and Development**

### **Sustainability**

- “The effort to frame social and economic policy so as to preserve earth’s bounty – its resources, inhabitants, and environments – for the benefit of both present and future generations. The old Native American proverb ---- We do not inherit the earth from our ancestors, we borrow it from our children.”

*Frank. H.T. Rhodes, President Emeritus, Cornell University, in Chronicle of higher Education, 20 October 2006*

### **Sustainability and Human Welfare**

“As countries work to improve the well-being of their people, they risk by-passing the goal of sustainability.--- People are turning resources into waste faster than nature can turn waste back to resources. ---Humanity’s ‘ecological footprint’ – the demand people place on the natural world- has more than tripled between 1961 and 2003.”

*James Leape, Director General WWF*

Reuters, 24 October 2006

## Population and Consumption Statistics

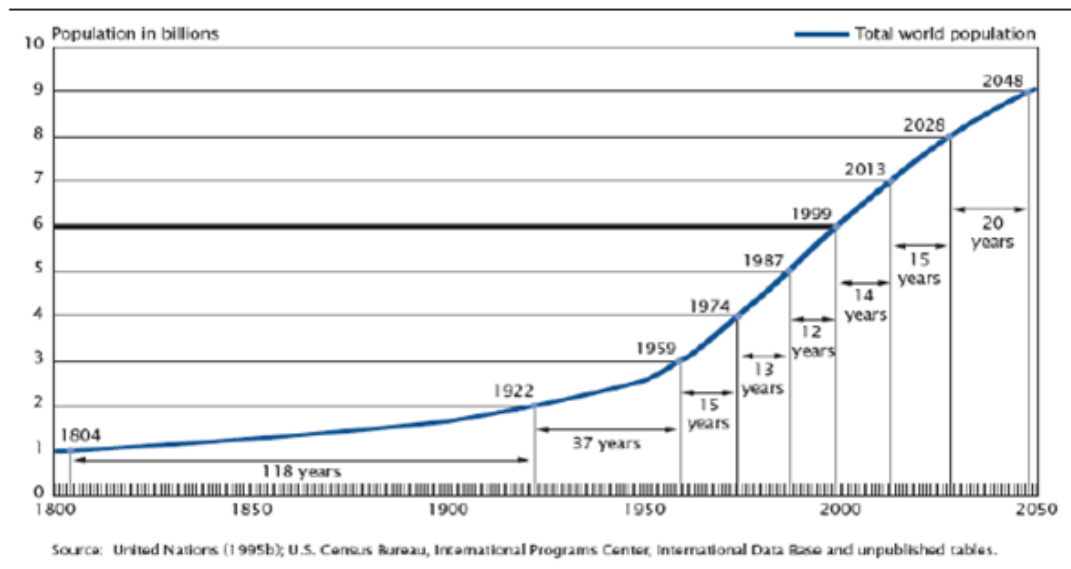
1950-2000

- Population Doubled
- Food Consumption Tripled
- Fossil Fuel Consumption Quadrupled
- Energy Consumption more than Quadrupled



## World Population 9 billion by 2050

  
Washington  
University  
in St. Louis



## Challenges for Sustained Improved Quality of Life on Planet

### U.N. Millennium Goals for Humanity


- Water
- Food
- Health
- Education
- Poverty
- Environment

- Energy
- Democracy, Freedom and Security


*"All above require Science and engineering solutions"*

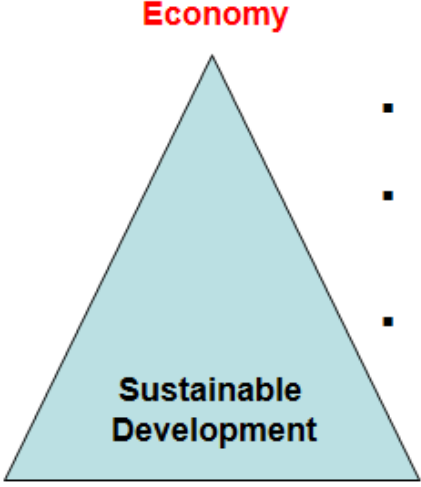
### Role of Engineer in Achieving Sustainable Development

- In all disciplines of engineering, engineers are engaged in development and creation of products and services for consumers.
- The creation of products requires material, energy, water and other resources and results in hazardous and non-hazardous waste and emissions, which have adverse impact on environment.
- The resources are finite and their demand is increasing due to increase in population and expectations for better quality of life by 2/3 of humanity.
- For sustainability, the goal is to minimize the consumption of resources as well as to minimize the impact on environment.



## Energy and Sustainability





**Economy**

**Environment**      **Stability and Security**

**Sustainable Development**

- Energy has critical relationship with three pillars of sustainable development.
- Sustainability requires secure, reliable and affordable supply of energy.
- Sustainable future is not static- it must be continuously redefined with new technical solutions.
- Sustainability requires that we look for **renewable energy solutions, emphasize conservation, and clean environment.**

### Product Design for Sustainability (DfS)

- Design for Sustainability means developing products with minimal or no environmental impacts – not ‘eco’ or ‘green’ products - but incorporating environmental considerations into good design practice for everyday products

## **Product Design for Sustainability**

- **“Products can be considered as the embodiment of environmental harm caused by production, consumption and disposal.”**
- *Eva Heiskanen, Finnish environmental economist*
- **It is estimated that 70% of a product’s environmental impact is locked in at the design stage.**

## **Key Principles of DfS**

- **Efficient design - keep the material and resource inputs (energy in particular) to a minimum.**
- **Cyclic design - design to enable materials to be continuously cycled through natural or industrial systems.**
- **Safe design - avoid toxic and hazardous substances and processes. Keep human health in mind as well as ecological impacts.**
- **Communications design - ensure product and packaging related communications are informative and accurate. Encourage responsible consumer behaviour.**

## **Example: Sustainable Transportation**

- **Technologies for Sustainable Environmentally Responsible Air Transportation**
- **Technologies for Sustainable Environmentally Responsible Ground Transportation**

## **Environmentally Responsible Sustainable Aviation**

- **Reduction in Energy Requirements**
- **Reduce the Vehicle Mass Using High Strength Low Weight Materials (Advanced Composites)**
- **Innovative Aircraft Designs (e.g. BWB) and Technologies (e.g. high L/D)**
- **Innovative Engine Designs (e.g. P&W PurePower)**
- **NextGen Air Traffic Management (ATM)**
- **Changes in Aircraft Operations (Reduce MTOW and Range)**
  - **Air-to-Air Refueling, Close Formation Flying, Tailored Arrivals**
  - **Reduction in GHG Emissions**
- **Alternative Fuels (Bio-fuels, Synthetic Kerosene)**
- **Innovative Aircraft Designs (e.g. BWB) and Open Rotor Engines, Low NOx Combustors**
  - **Reduction in Noise**
- **Innovative Aircraft Designs (e.g. Silent Aircraft SAX-40)**
- **Innovative Engine Designs (e.g. P&W PurePower)**
- **Airport Operations**

### **Environmentally Responsible Sustainable Ground Transportation**

- **Reduction in Energy Requirements**
- **Reduce the Vehicle Mass Using High Strength Low Weight Materials**
- **Smooth the Operational Speed Profile**
- **Reduce Viscous Drag and Tires Contact Friction**
- **Efficiency Improvement by Automation**
- **Efficient Utilization of Infrastructure (Roads, Highways etc.)**
- **Improve Engine Efficiency, Hybridization**
  - **Reduction in GHG Emissions**
- **Carbon - Based Fuels Synthesized from low carbon energy, e.g. Biofuels (Development of low cost catalysts capable of converting low-carbon energy into and out of forms amenable for portable storage)**
- **Portable Storage of Low Carbon Electricity (Development of Batteries with high energy density and stability)**
- **Hydrogen Production, Storage and Fuel Cells**

### **Introducing Sustainability Concepts in Aerospace Courses at WUSTL**

- **Aerospace Minor**
- **MEMS 2701 - Introduction to Aerospace Vehicles**
- **MEMS 5700 - Aerodynamics**
- **MEMS 5701 - Aerospace Propulsion**
- **MEMS 4302 - Aircraft Stability and Control**
- **MEMS 321 - Structural Behavior and Analysis**
- **MEMS 411 - Mechanical/Aerospace Design**

### **Inclusion of Sustainability in Aerospace Courses at WUSTL**

- **MEMS 2701: the issues of environmental challenges such as noise and emissions are introduced in the context of current status and projected increase in noise and emissions in next twenty five years due to three fold increase in air travel (and as a result two fold increase in flying aircraft). If no new technologies are introduced and status-quo is allowed to remain, the aircraft emissions will contribute about 17-20% to total equivalent CO<sub>2</sub> emissions from all sources worldwide, which will not be acceptable because of worldwide efforts to reduce greenhouse gas (GHG) emissions due to their adverse impact on climate.**

### **Inclusion of Sustainability in Aerospace Courses at WUSTL**

**MEMS 5700: The concepts of drag reduction using active flow control and laminar flow wing are explained in the context of fuel savings and in turn in reducing the emissions. The design and performance of Honda Jet , which has natural laminar flow wings is compared with other conventional wing aircrafts in fuel efficiency. The basic concepts behind the newly emerging aircraft designs/configurations such as**

**Blended –Wing –Body, Silent Aircraft, Hydrogen Power Aircraft, Solar Power Aircraft, and Electric Aircraft are introduced as ways of reducing noise and emissions. One can design aircrafts which can be fuel efficient and reduce emissions. The contents of this course are closely coordinated with the aircraft design course MEMS 411.**

#### **Inclusion of Sustainability in Aerospace Courses at WUSTL**

- **MEMS 5701: The concepts of high bypass engines and geared turbofans for improved efficiency are introduced. The alternative technologies such as fuel cells, solar power and hydrogen for propulsion are introduced. The alternative fuels such as biofuels and syngas fuels which have reduced emissions compared to currently used jet fuels are introduced. The use of chevron nozzles can reduce noise as well as special flight paths can change the directivity of noise near airports to help mitigate its effect on people living near airports. These ideas are brought to focus in this course.**

#### **Inclusion of Sustainability in Aerospace Courses at WUSTL**

- **MEMS 321: The concepts light weight materials such as Carbon Fiber Composites (CFC) and metal composites are introduced. Structural analysis of aircraft components such as wings and fuselage using these materials is introduced.**

#### **Inclusion of Sustainability in Aerospace Courses at WUSTL**

- **MEMS 411: The concepts of innovative aircraft designs such as BWB, Double Bubble etc. are introduced. The students are encouraged to come up with their own concepts. The project involves a team of 4 - 6 students.**

#### **Conclusions**

- **It is increasingly recognized that the concepts of sustainability should be introduced in engineering curriculum.**
- **Among many facets of sustainability, environmental sustainability has become one of the most important topics because of its direct impact on human health and welfare, and climate change.**
- **In this talk, we have tried to show how some of the environmental sustainability ideas can be introduced in the existing undergraduate aerospace engineering courses without changing the core content of the courses.**
- **We will be reporting our experience in this area in future ASEE conferences which may be beneficial to other engineering schools as they contemplate introducing sustainability in the curriculum.**



## **SECTION 1**

## **Integration of Matlab in Engineering and Engineering Technology Curriculum**

Raymond Addabbo  
Professor Arts and Sciences  
Vaughn College of Aeronautics and Technology  
86-01 23rd Ave.  
East Elmhurst NY 11369  
718-429-6600 (261)  
[raymond.addabbo@vaughn.edu](mailto:raymond.addabbo@vaughn.edu)

# **Integration of Matlab in Engineering and Engineering Technology Curriculum**

This paper presents the course content of **Introduction to Programming** (CSC 215) and its importance in the engineering and engineering technology curriculum. Specific student outcomes, such as programming techniques, modeling, data interpretation and error analysis will be presented. In addition, it will be shown how CSC 215 is used as a transition course from the first year courses to upper level engineering courses. Finally, material will be presented on techniques used in the class to foster higher order problem solving skills.

Raymond Addabbo  
Professor Arts and Sciences  
Vaughn College of Aeronautics and Technology  
86-01 23<sup>rd</sup> Ave.  
East Elmhurst NY 11369  
718-429-6600 (261)  
[raymond.addabbo@vaughn.edu](mailto:raymond.addabbo@vaughn.edu)

## **1 Introduction**

In spite of computational skills being deemphasized in many curricula, the importance of these skills has never been greater. With the increase in computer speed over the last thirty years, computation has become a partner to experiment and theory. Many diverse phenomena in engineering and science are too expensive or dangerous to study in a laboratory and can only be studied using numerical simulations.

The course Introduction to Programming using Matlab (CSC 215) taught at Vaughn College serves to address several issues. The fundamental goal of the course is to teach programming by integrating different parts of the engineering curriculum. Theory taught in other courses can be verified or questioned using numerical simulations. In order to accomplish these goals, several skill sets need to be developed. This paper addresses these skill sets and how they are developed.

## **2 Outline of CSC 215**

CSC 215 is a three credit required course for engineering students and an elective in the engineering technology programs. A typical engineering student will take the course in the fall semester of his or her sophomore year. Students at this point have taken the typical one year calculus and physics sequence and an engineering course. During their third year they will take a computational engineering course where they will use finite element analysis. After spending their freshman year learning about limits in calculus, they are now expected to set up a discrete grid and look at the derivative of a function in a different way. CSC 215 serves as a bridge between the first year and more advanced courses.

The course is roughly divided into two parts. The first part covers basics of Matlab, using m files, operations with matrices, graphing functions, logical and relational operators, control loops and variable assignments. Each concept is motivated by a specific example from mathematics or physics. Students are given projects and are graded on the functionality of the program and the programming style. The students are given a midterm based on these basics.

The second half of the course is used for project work. Students are divided into groups of two or three and given a project based on their interest. The expectation is that students will collaborate and use techniques learned in the first part of the course. Descriptions of several projects and an example of a final group project are given below with comments.

### 3 Projects

- a. **Introduction to Matlab:** This first project requires students to become familiar with using m files. Basic matrix properties are taught in class. They are to write a m file that does basic matrix operations. They are also asked to graph several functions on one plot.

**Skills:** For this first project students become familiar with the Matlab environment. They learn how to write and assign variables to matrices. Part of the functionality of Matlab is its ability to write special matrices, students are exposed to some of them. Syntax such as, parenthesis, brackets, semicolons, colons and periods are presented.

- b. **Newton's Root Finding Method:** This project requires students to write a program to find the root of an equation. Examples are polynomials with irrational roots and equations with transcendental functions. The algorithm used is derived in class.

**Skills:** Students are required to write the algorithm as a program. They need to understand the difference between an equal sign used in mathematics and an equal sign used in a program (an assignment). In addition, control loops are used, the program is required to stop after a specific absolute error. Students are given problems where the function is asymptotically horizontal; they are encouraged to think about the behavior of the function they want and to make informed decisions about their initial guess.

- c. **Monte Carlo Calculation:** A Monte Carlo technique is used to calculate the value of  $\pi$ . A short history of the subject is discussed in class. The technique is introduced by illustrating a circle in a square and calculating the ratio of trials that are in the circle to the total number of trials. This project introduces the importance of probability as a computational tool.

**Skills:** Matlab's random matrix feature is used, along with control loops to determine if a pair of random numbers falls inside the circle. Students also see that

since the random matrices are different each time the program is executed the will obtain different results.

- d. **Numerical Differentiation:** Students are asked to write a program that differentiates a function using a matrix. Part of the program asks them to find critical points of the function.

**Skills:** The importance of this project cannot be over emphasized. During class several schemes for differentiating are taught along with their respective errors. Students are exposed to the concept of a mesh grid and the relation of the size of the grid to error and number of operations. Students must be able to write these difference schemes as a matrix and implement them using Matlab's sparse matrix features. Finally, logical searches are used to find roots and extremum.

**4 Final Project:** In this part of the course, projects are picked according to the interest of the students. The common theme is to apply what they have learned to a new situation. Each group is to produce a written report that contains an explanation of the model, the mathematics behind the model, the actual Matlab program and interpretation of results. Two typical examples are provided below.

- a. **RCL Simulation:** Students interested in electrical engineering are asked to do a numerical simulation of a RCL circuit, with different types of sources. They need to explain the model (with appropriate units) and arrive at the differential equation. The next step is to use Taylor series to arrive at an Euler approximation. Although explicit methods are easier to program, there are issues of stability. Part of the written report requires students to justify values of their parameters. Finally, students are to demonstrate an understanding of fundamental parameters of the problem. In particular this is illustrated by graphing special cases and being able to interpret results in a oral presentation.
- b. **Stress on a Beam:** Students in this program will study the deflection of a beam when different loads are applied. This is different than the problem described above since it is a boundary value problem. In addition the governing equations are fourth order, requiring students to extend their difference equation. Students doing this project will see a boundary value problem for the first time. The issue then becomes one of using an implicit method. Given Matlab's functionality of solving systems of equations this problem becomes more accessible for students. For this project students are asked to look at different types of loads on the beam and to explain their results.

**5 Assessment:** Students are required to hand in a hard copy of each of the projects. They are graded on the functionality of the program and style. The first issue is whether the program does what it is supposed to do. Students are to explain if there are exceptions to

data that can be used, for example in Newton's root finding method an initial point where the slope is horizontal will give an over flow error. The second issue has to do with presentation, comments need to be used, condition statements are to be indented appropriately and the assignment of variables should make sense.

The midterm exam is used to evaluate a basic knowledge of programming and Matlab syntax. Students are asked to write a simple program illustrating the use of control loops, command of basic matrix operations are assessed and knowledge of syntax is required.

The final project is used to give students the opportunity to work together. There are several aspects of the final project that is used to assess students. Students are broken into groups of three or four. Each group is to decide the breakdown of responsibility. One student will present the model, another will explain the mathematics, a third will explain the programming and the last will interpret results. The entire group is responsible for the over all quality of the report and the oral presentation. Students are given fairly free reign over their project, however regularly scheduled meetings with me are required to make sure the focus remains. The final grade is based on the overall quality of the report and presentation, the technical content is judged as well as the student knowledge of each others work.

**6. Conclusions:** CSC 215 has been taught each semester for about the past five years, mostly by the author. Originally, it was offered as an elective. The enrollment has always been good, which was encouraging enough to think the students saw value in taking the course. There are several issues in teaching the course; the first is that I stopped requiring a text book since it was the main criticism of the course from student valuations. At this point, I use my lecture notes and mention to students that the **Matlab Primer** is helpful. When I started teaching the course I was going to the computer lab with the students to help them with their projects. At this point, I rarely go to the lab, if they have difficulty; they may come to my office with their file on a disk. It takes time for students to get used to using Malab, most of them are used to using programs where they see what they have on the screen. In addition they must become careful in how they assign variables, and use the syntax. A useful approach in the classroom is to give students a assignment to write a program, then have another student evaluate if it will work.

**7. Future Directions:** It is my hope that Matlab will become the primary computing tool at Vaughn College. Matlab has many features that are not studied in CSC 215 that can be incorporated into other courses, such as the ODE solvers, symbolic capabilities and Simulink. Currently, Vaughn has a required seminar for freshman that covers information literacy. It would be very helpful for freshman to have enough Matlab skills so that they can graph functions and incorporate them into a document. Finally, as was discussed in the introduction about computer skills being deemphasized, I would like to see computation to become an equal partner in the engineering programs.

## Bibliography

1. SIAM Working Group on CSE Undergraduate Education, Peter Turner and Linda Petzold Co-Chairs, Undergraduate Computational Science and Engineering Education, SIAM Review, Vol 53, No. 3, pp 561-574.
2. Little, Leigh J., The Computational Science Major at SUNY Brockport, Future Generation Computer Systems, Vol 19, 2003, Pp 1285-1292.
3. Davis, Timothy A., **Matlab Primer 8<sup>th</sup> ed.**, CRC Press, 2010.
4. Turner, Peter R., **Teaching Scientific Computing Through Projects**, J of Eng Ed. 90 (2001), PP. 79-83.

## **Implementing Single-Scale Retinex on Hardware: A Pilot Study**

Ilan Alpert  
Morgan State University  
Department of Electrical and Computer Engineering  
1700 East Cold Spring Lane  
Baltimore MD 21251 USA  
ilalp1@morgan.edu

ILAN ALPERT  
Masters of Electrical and Computer Engineering.



# Implementing Single-Scale Retinex on Hardware: A Pilot Study

*Abstract-* The Retinex algorithm, a process that automatically improves visual realism in images, has been successfully implemented in software but has not effectively been applied to hardware. While both software and hardware essentially perform the same function, there are many advantages in using hardware to directly implement the algorithm. Hardware has a size advantage, with only one or two circuit boards being needed, as well as greater speed and the ability to directly connect and use inputs and outputs. Prior work on Retinex has shown that software and Digital Signal Processing (DSP) implementation have been successfully accomplished with many types of images [1,2,3]. In the study reported in this paper, Retinex was implemented in the VHDL language and synthesized onto a Field Programmable Gate Array (FPGA). A forward looking infrared (IR) image of a runway taken from an airplane during landing was the image used to test Retinex. Preliminary findings suggest that hardware can be used to successfully execute the Retinex algorithm. This will enable future research using real-time cameras and display units.

## I. INTRODUCTION

Runway incursion is the incorrect presence of an aircraft, vehicle or person on a runway that could compromise or jeopardize safety during take-off and landing. While not all incursions lead to serious/dangerous outcomes, runway incursions are rising at an alarming rate at airports in the United States. In 2005, for instance, 327 incidents were reported, and in 2009, 951. The highest number of runway incursions was recorded in 2008 with 1009 incursions [4]. From 2005 to 2008 there was a 308% jump in runway incursions. An issue with runway incursion is the pilots' ability to see the intrusion on the runway [5]. A big contributor to this is bad weather and low lighting conditions. As proposed here, airplanes can be outfitted with cameras for easier out-of-window viewing. This could help pilots to see more of what is happening on the runway. However, in bad weather and low light conditions, being able to look outside does not always help without the right hardware.

The Retinex is an image enhancement algorithm that is used to improve visual quality of an image by improving color consistency, contrast and brightness, as well as sharpness. It is an automatic method that is done through dynamic range compression. Recorded images lose a lot of visual quality when compared to the human vision system. Retinex corrects this by bridging the gap between human observation/sight and images taken by a camera. In 1986, Edwin H. Land [6] proposed an algorithm based on the human vision system and specifically lightness and color consistency. The word *Retinex* comes from "retina" and "cortex," which implies that both the eyes and brain are involved in the vision system. This algorithm has successfully been applied to multiple fields such as medicine, forensics, science, and aerospace.

Infrared (IR) cameras can be used to see through cloudy and bad weather conditions, and do not depend on light for the images to be viewable. While IR cameras can be used anytime, day or night, images taken with these cameras do not always show what one needs to see. Combining IR images and Retinex can be very useful for finding information about your surroundings that you would not normally be able to see unless the right

conditions with light and weather. The advantage of Retinex is the ability to make the image lighter and to bring out important information from the image for viewing. A specific portion of the image, like a runway, for instance, can be extracted from an IR image and run through Retinex. This yields an image that could show if there are any obstructions on the runway, thereby making landing safer and easier.

## II. Background

Retinex has been used for different purposes. One article, titled “Retinex Processing for Automatic Image Enhancement” uses Retinex with color images. Retinex is used as a platform for synthesizing local contrast improvement, color constancy, and lightness/color rendition, all as a goal for digital image enhancement. Their Retinex process was done using software. Human vision encompasses a wide dynamic range and provides color consistency, which they were able to use Retinex to mimic, and therefore successfully implement Retinex for image enhancement in software. Another article, titled “Retinex Enhancement of Infrared Images” uses multiple forms of Retinex to enhance infrared images. Of the eight types of image enhancement techniques employed, different forms of Retinex made up five tested methods. The conclusion drawn was that Retinex was a very versatile automatic image enhancement method, which could simultaneously provide different enhancements needed to successfully work on the infrared images used.

For successful implementation into hardware, the Retinex algorithm will require a processor capable of handling the complex mathematical operations involved, which requires hardware with speed and versatility. The hardware will need to be able to do the operations with enough speed to take the image from a real-time IR camera and output it directly onto a viewable screen, all while performing Retinex on the image. A Field Programmable Gate Array (FPGA) was used for this task. It has the versatility to connect to an IR camera and output to a screen for viewing, as well as the speed to do the complex operations that are required [7,8]. Different architectures could be chosen. In the present study, the Xilinx Virtex 4 was used because of its enhanced capabilities and the fact that it was readily available.

## III. Methodology

For the Chesapeake Information Based Aeronautics Consortium (CIBAC), the focus of the pilot study was on implementing Single-Scale Retinex (SSR) in MATLAB, and working on writing VHDL code to simulate SSR onto an FPGA. The SSR in MATLAB was simulated on an Infrared (IR) image taken from an airplane with a forward-looking infrared camera (FLIR), as depicted in Fig 1. For coding in VHDL, a 5x5 pixel array was used to test the algorithm written.

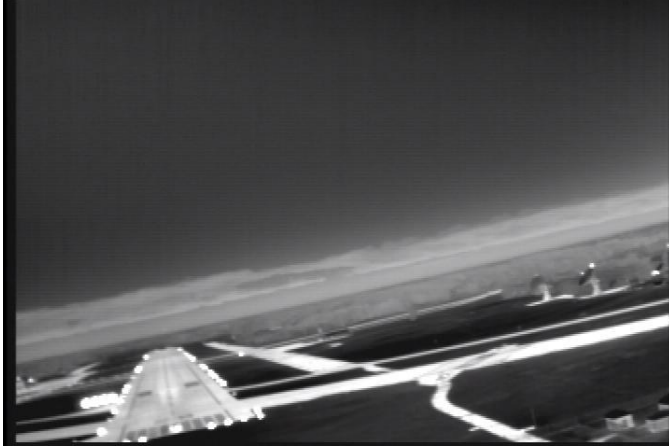


Fig 1. Original FLIR image of runway

MATLAB is a numerical computing environment that can be used with many different equations and mathematical formulas for simulation. The focus of the present study was on image enhancement, so the built-in image processing toolbox was used [9]. This toolbox provides the necessary graphic tools for image processing and analysis.

Retinex is a member of the class of center surround functions. The output pixel is determined by the input pixel (center) and its neighbors (surround). In the case of Retinex, the center is each pixel in the image, and the surround is the Gaussian surround function. There are different forms of Retinex, but the one used in this study was Single-Scale Retinex. The rationale for using this version was because the IR image was in grayscale. The mathematical form of SSR is given by

$$R(x, y) = \log(I(x, y)) - \log(I(x, y) * F(x, y))$$

where  $I$  is the input image and  $R$  is the output image. The symbol “\*” represents convolution. Convolution is a modification of a pixel’s value based on the neighboring pixels. It works by taking the image as one array of pixels and a filter as a second array, usually of a specified size. In this case, the Gaussian is the filter, and multiplies the pixel from the image by the center pixel of the filter and the neighbors of the image pixel by the neighbors of the filter pixel. The pixels are then summed and normalized, and produce an output pixel for the output image.  $F$  is a Gaussian surround function, which is a filter defined by

$$F(x, y) = K \exp[-(x^2 + y^2) / \sigma^2]$$

where  $\sigma$  is the Gaussian surround space constant and  $K$  is defined by

$$\iint F(x, y) dx dy = 1$$

which is a normalization factor for the Gaussian surround function.

The one problem with the Retinex equation in terms of hardware, is the convolution. Convolution is a very resource-intensive function and because the goal of the research was to implement Retinex onto hardware, alternatives to convolution had to be examined/explored. From the Fourier Transform pairs, we know that convolution is equal to multiplication after using the Fourier Transform shown by

$$f(x, y) * g(x, y) \Leftrightarrow F(\mu, \nu)G(\mu, \nu)$$

Knowing this, we can get rid of convolution and use multiplication, which is a smarter option for hardware implementation. The rewritten Retinex equation is as follows

$$R(x, y) = \log(I(x, y)) - \log[F^{-1}(I'(\mu, \nu)F'(\mu, \nu))]$$

where  $I'$  and  $F'$  represent the Fourier Transforms of  $I$  and  $F$ , and  $F^{-1}$  represents the inverse Fourier Transform.

The Gaussian Surround Function is similar to a Bell Curve (see Fig 2) where one side is equal to the other. With a Gaussian, the highest point is equal to 1 and the outer perimeter gets close to zero, with numbers between them making up the connecting curves that mirror each other on their opposite sides (see Fig 3). The highest point is also used as the pixel to perform a function on the pixel being manipulated in the original image.

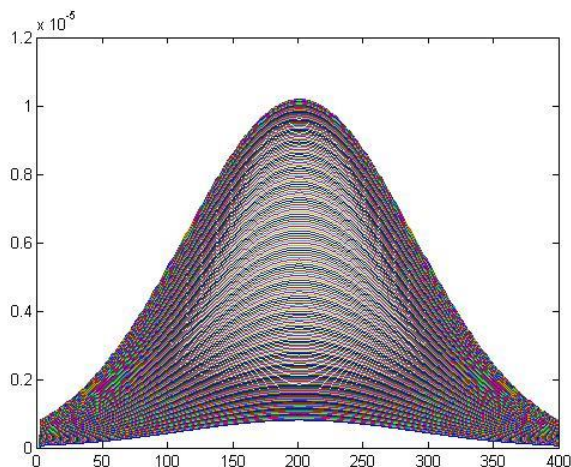


Fig 2. A One-Dimensional view of the Gaussian Surround Function

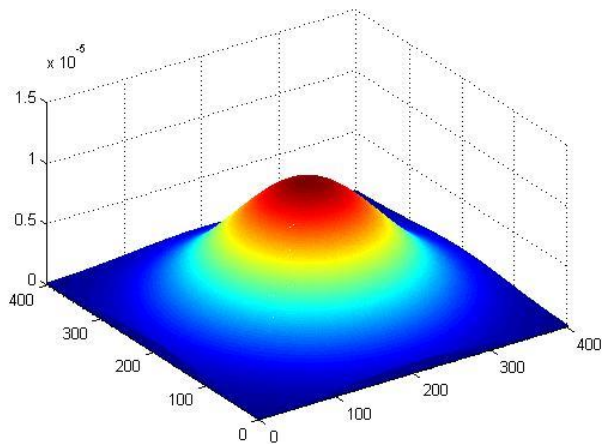


Fig 3. A Two-Dimensional view of the Gaussian Surround Function

The processor used for the hardware under focus in the research reported here is FPGA, which stands for Field Programmable Gate Array. An FPGA is an integrated circuit that can be configured after manufacturing. This makes it a good option for Retinex, because it can be modified and reprogrammed if ever needed without having to manufacture another. It also offers flexibility with regards to inputs and outputs, and has a good speed at which it can execute the complex and numerous functions/operations required of it with Retinex. The programming language used to program the FPGA is an HDL, which is a hardware description language. The exact HDL used was VHDL. The V stands for Very-high-speed integrated circuit. One of the advantages of using VHDL is the built-in Fast Fourier Transform (FFT) IP Core that is built into the software suite used, and is implementable on the hardware (see Fig 4).

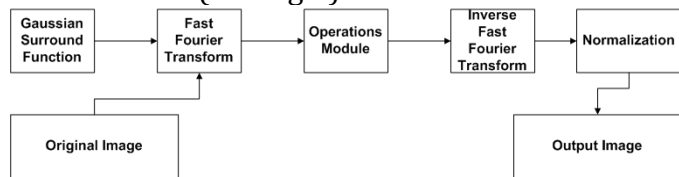


Fig 4. Block diagram of FPGA Retinex Architecture

The camera used with SSR in this study was an IR camera, specifically a FLIR. Using an IR camera with flight could have many advantages. It works in poor visibility conditions and is not affected by bad weather. It can work both day and night because it picks up the radiance of the objects, runways and taxi light, regardless of the time of day. IR cameras work by detecting the electromagnetic radiation between specific wavelengths, which the camera is calibrated to see. Hot objects will appear as white in a grayscale image, and cold ones will be black, with variations in between.

#### IV. Results and Discussion

Findings from the present study suggest that Retinex could indeed be integrated onto hardware for the purpose proposed. Ongoing research is being conducted in the design and

coding phase with implementation onto hardware in the near future, making the pilot study reported here a realistic goal. The IR image has been tested to work with Retinex and appears to be implementable when it is applied to hardware (see Fig 5).



Fig 5. SSR run on whole image

The one obstacle encountered is that for Retinex to work best on the IR image, the runway section of the image needs to be segmented and run through the algorithm as opposed to running the entire image. Without segmenting the runway, the darkness of the IR image negatively affects the outcome (see Fig 6). This could cause the runway section of the image to not be as visible because important information on the runway (for example the markings), would not be highlighted. Prior research does not report this particular problem.

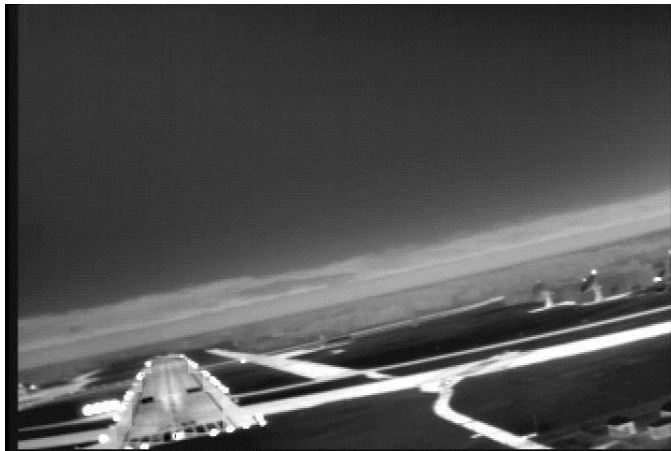


Fig 6. SSR run on segmented Runway

Another challenge encountered has to do with the Gaussian Surround Function that is used in the Retinex Algorithm. Different methods of implementation of the Gaussian surround function have been reported in prior research [2]. Depending on how the Gaussian function is implemented, different results emerge. Based on the equation of the

function, the 2-dimensional Gaussian will only be one quarter of a full Gaussian model (see Fig 7).

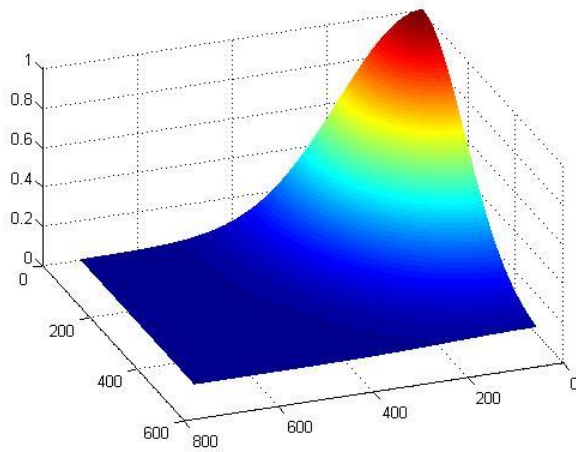


Fig 7. A quarter of the Gaussian Surround Function

Prior research has reported using a different variation of this filter that models a full two-dimensional Gaussian. The challenge from these findings is how to best implement the Gaussian surround function to yield the best results. This finding suggests that further research needs to be done on the Gaussian surround function itself.

With regards to the FPGA and VHDL code, around 75% of it was completed in this Pilot Study (see Fig 8). A 5x5 pixel array was chosen to test the code, making for a much easier test environment. Once the achieved results produce the correct output numbers, the full size image of 640 by 480 pixels can be run through the code, after the data bus adjustments are made. The built in FFT IP Core was initialized and is fully working as a module. The FFT IP Core was used for multiple modules within the system since both the Fourier Transform and Inverse Fourier Transform were needed. The majority of the coding has been completed, with only a couple modules left to complete. Testing is being conducted on the accuracy of the outputs from the FFT IP Core in conjunction with coding. Once all modules are written and simulation testing is completed, a state machine controller will be written to manage the entire system. Once the entire system is tested in simulation, hardware testing will begin. The results have been good thus far and progress is being made.

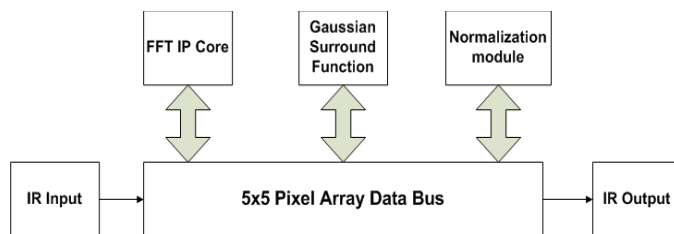


Fig 8. VHDL block diagram

## V. Conclusion

This pilot study has shown that Retinex indeed improves the visibility of objects of IR images. With respect to looking at the runway section of an image, segmentation is needed to get the objects and lights on the runway more visible and distinguishable. The FPGA architecture is showing potential with the code written so far, but further research is needed to verify this. With the use of Retinex and segmentation of the runway in an FLIR, runway safety could be improved. Incursions could possibly be detected better in low visibility and bad weather conditions. This would improve the overall safety of flights with respect to landings and possibly reduce the number of accidents caused by runway incursions.

## VI. Future Work

Future research is needed on the correct way to represent the Gaussian surround function in the Retinex Algorithm. Further work on the VHDL code is also needed before full implementation of Retinex onto hardware can occur. A full size IR image will be tested on the hardware when ready, and then an IR camera and monitor output will be used to run the Retinex in real-time. These are all goals that will be completed at the end of the research, and this pilot study has helped us to get closer to the final product.

## ACKNOWLEDGMENTS

The author wishes to thank Dr. Jumoke Kemi Ladeji-Osias for her continued guidance and support in this pilot study and with future research. The author would also like to thank the Chesapeake Information Based Aeronautics Consortium for the funding which made this research possible. Special thanks goes to Dr. Anita Pandey for her technical guidance, as well as to Dr. Craig Scott, Dr. Eugene Deloach, Mr. Gilbert Haynes and Morgan State University.

## REFERENCES

- [1] Z. Rahman, D. J. Jobson, and G. A. Woodell, "Retinex Processing for Automatic Image Enhancement" *Journal of Electronic Imaging*, January 2004.
- [2] Y. Li, R. He, G. Xu, C. Hou, Y. Sun, L. Guo, L. Rao, and W. Yan, "Retinex Enhancement of Infrared Images" *International IEEE EMBS Conference*, Vancouver, British Columbia, Canada, August 2008.
- [3] G. D. Hines, Z. Rahman, D. J. Jobson, G. A. Woodell, "Single-Scale Retinex Using Digital Signal Processors" *Global Signal Processing Expo (GSPx)*, 2004.
- [4] Runway Safety Statistics (2010), In *Federal Aviation Administration*. Retrieved Wednesday July 28, 2010, from [http://www.faa.gov/airports/runway\\_safety/statistics/](http://www.faa.gov/airports/runway_safety/statistics/)
- [5] G. S. Rajput, Z. Rahman, "Hazard Detection on Runways using Image processing Techniques" *Enhanced and Synthetic Vision 2008*, Proc. SPIE 6957, 2008.
- [6] E. Land, "An alternative technique for the computation of the designator in the Retinex theory of color vision" *Proc. Nat. Acad. Sci.* 83, pp. 3078-3080, 1986.



- [7] C. T. Johnston, K. T. Gribbon, and D. G. Bailey, "Implementing Image Processing Algorithms on FPGAs" Institute of Information Sciences & Technology, Massey University, Palmerston North, New Zealand.
- [8] A. E. Nelson, "Implementation of Image Processing Algorithms on FPGA Hardware" Master thesis, Vanderbilt University, May 2000.
- [9] B. Funt, F. Ciurea, and J. McCann, "Retinex in MATLAB" *Journal of Electronic Imaging*, January 2004.

## **eTutor – An Interactive Module for Electrical Engineering Curriculum**

RUBA A. AMARIN  
University of Central Florida:  
Dept. of Electrical Engineering and Computer Science  
Orlando, United States  
ramarin@knights.ucf.edu

ISSA BATARSEH\*  
Princess Sumaya University for Technology  
Amman, Jordan

RUBA A. AMARIN

Ruba A. Amarin is with the University of Central Florida, Orlando, FL 32816 USA. Ruba received the B.S. degree in Electronic Engineering from the Princess Sumaya University for Technology, Amman-Jordan in 2004; she afterwards received her M.Sc. degree in Electrical Engineering, Tele-Communication track from the University of Central Florida, Orlando in 2006. In 2010, Ruba received her PhD in Electrical Engineering, conducting research in Satellite and Remote Sensing under the supervision of Dr. Linwood Jones.

ISSA BATARSEH\*

\*Dr. Batarseh is on Professional Development Leave at (PSUT)

Issa Batarseh is currently on professional development leave at the Princess Sumaya University for Technology (PSUT) (e-mail: batarseh@mail.ucf.edu). He received the B.S. degree in Computer Engineering and the M.S. and Ph.D. degrees in Electrical Engineering from University of Illinois, Chicago, in 1983, 1985, and 1990, respectively. He was a Visiting Assistant Professor of Electrical Engineering at Purdue University, Calumet City, IN, from 1989 to 1990 before joining the Department of Electrical and Computer Engineering at the University of Central Florida, in 1991. He has more than 14 U.S. patents, and more than 50 refereed journal and 200 conference publications.

## ***eTutor* – An Interactive Module for Electrical Engineering Curriculum**

*Abstract*— The interactive technical electronic book, TechEBook, currently under development at the University of Central Florida (UCF), introduces a paradigm shift through replacing the traditional electrical engineering course with topic-driven modules that provides a useful tool for engineers and scientists. The TechEBook has comprised the two worlds of classical circuit books and an interactive operating platform such as iPads, laptops and desktops. The TechEBook provides an interactive applets screen that holds many modules, in which each had a specific application in the self learning process.

This paper describes one of the interactive techniques in the TechEBook known as, Tutor-Me Module (*eTutor*). The *eTutor* Module is a step-by-step problem solving program that will help in testing the understanding of key components presented in the TechEBook using an interactive circuit solver. This module will be displayed after each section in the TechEBook for the user to interactively solve problems. This tool also guides the user through detailed analysis steps of common electrical circuit problems. A practical example of applying the *eTutor* feature is discussed as part of a basic electrical engineering course currently given at UCF and results show improved student performances in learning materials in Electrical Circuits.

Keywords-component; Tutor-Me Module; Tool; Electrical Circuits; Interactive book

### I. Introduction

The interactive **technical electronic book** (TechEBook) serves as a modern, media-rich innovative approach to a topic-driven modular electrical engineering curriculum that recognizes the different learning approaches for different users. The TechEBook consists of 16 chapters, a total of 75 sections representing typical content for the introductory circuit course at most universities in the world. Each section discusses a new theory and concept that are supported with examples and problems [1]. Different topics are presented in discussion text material that provides full understanding of the concept while maintaining user's self-remediation and self-paced learning. At the end of each section, QuizMe Modules are provided to quiz the students' understanding of the section [2]. Also, Design Modules (DM) are intended to help students develop their ability to design real life problems, and to link the theories they study in books with real design challenges, while the Practical Relevance Modules (PRM) are set to enhance the student thinking about real life problems and also teach students how to relate the theories they have learned with practical applications [3]. Finally, the Tutor-Me Module is intended to help understanding basic concepts in a step-by-step manner.

### II. Objectives

At the University of Central Florida, efforts are underway to develop the full content of the TechEBook using the above attributes of each section. Tutor-Me Module is one major component of the TechEBook currently being developed through partial funding from the National Science Foundation (NSF). The main objective of including this module is to illustrate a further level of interactivity, where the user can contribute to the solution of circuit's parameters by inputting equations and getting immediate feedbacks about the validity of the mistakes, how to overcome them and the specific areas they need to improve in.

This work is partially funded by NSF –CCLI Award Number: 0837364 . The work is done while the author is on professional development leave from UCF.

The *eTutor* tool guides the user through a step-by-step analysis of common electrical circuit problems. In each step, the tool prompts the user to enter a formula that best describes the current step in the analysis method. Then, the tool responds with personalized feedback that is dependent on the user's formula. Through the feedback process, the tool targets all lexical and analytical errors in the user input. The tool compiles a list of errors and warning messages that are reported back to the user. Trials and interactive elaboration on errors allow the user to better understand the targeted concept in circuit analysis. More importantly, each user learns at his/her own pace, based on their individual learning styles.

The modular and template-based design for the tool allows the instructor to add and modify key problems. With the *eTutor* tool, users will be able to solve problems and obtain the same type of specific feedback they would receive from the class instructor.

### III. Tutor-Me Architecture

The *eTutor* was developed using Java programming language as a backbone to collect data for testing purposes [4].

TABLE 1 <b>Window</b>	<b>Functionality</b>
Step Instruction	Provides a brief overview of the problem and description of the followed procedure
Circuit	Provides an illustration of the specific method used through circuits
Input	Provides the place to solve the question by inputting the resulting equation for the specific step
Feedback	Provides feedback based on the equation entered. If the wrong equation was entered, the feedback window will specify the error

The *eTutor* Graphical User Interface (GUI) screen is composed of four main windows; the *step instruction window*, the *circuit window*, the *input window* and the *feedback window*. These windows are designed especially to provide the ultimate help and guidance throughout the learning process. Table 1 summarizes the main functionality of each window.

The software will easily allow the user to select the circuit example of interest from the 'Choose Circuit' dropdown menu which is designed such that the instructor can add circuits easily as shown in Fig. 1. *eTutor step instruction window* will then introduce the problem and what method of analysis to use and how to proceed with the solution. In this paper, a mesh-loop example will be presented to fully explain the functions of the different interactive windows.

Each step provides the needed description of the problem and what are the parameters that need to be solved for (*step instruction window*) and the associated circuit image (*circuit window*) as shown in

Fig. 2. The user can then walk through the example step-by-step using the navigation buttons. The next step is solving the problem. The *eTutor* will now enable the *feedback window* and the *input window*. Clicking on the 'Check Eqn' after inputting the answer will enable the *feedback window*, which will show the results of the parsing and analysis operation and will provide feedback on whether the inputted equation is right or wrong as shown in Fig. 3.

The *feedback window* will not only inform the users if their input to a question was right or wrong, it will also specify what type of error was made in the symbolic equation and will provide the standard

equation for the step. The *eTutor* can accept many forms of an answer; it will know all the equivalent answers, analyze them and provide the proper feedback.

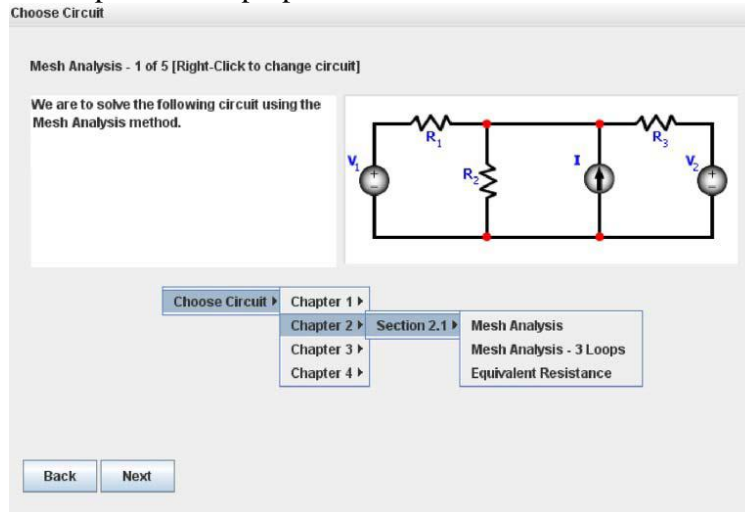


Figure 1. *eTutor* main GUI.

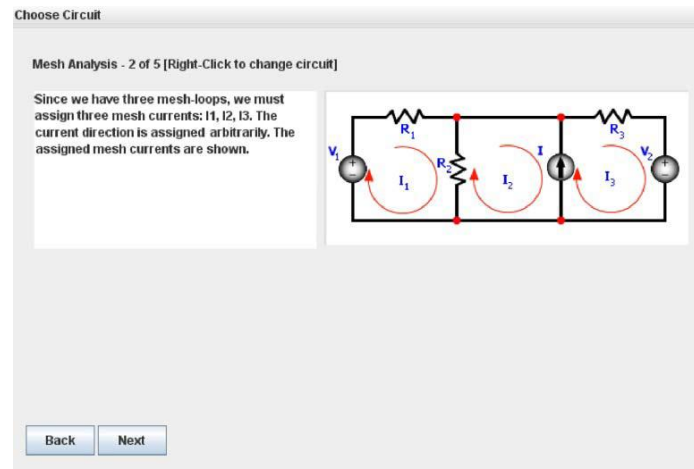
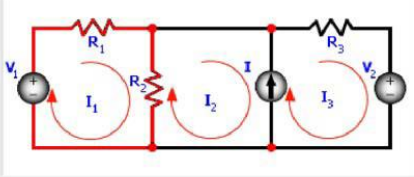


Figure 2. *eTutor* step instruction window.

Choose Circuit

Mesh Analysis - 3 of 5 [Right-Click to change circuit]

Input the KVL equation for the mesh loop highlighted in red. Then Click on 'Check Eq' to check your answer.



Please enter your equation here

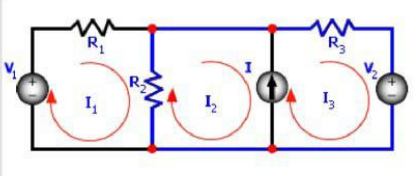
INFO - You wrote the correct equation  
 INFO - You wrote the equation in the standard format  
 Standard Equation:  $-V1+R1*I1+R2*(I1-I2)=0$

Figure 3. *eTutor* input and feedback windows.

Choose Circuit

Mesh Analysis - 4 of 5 [Right-Click to change circuit]

We must focus on one mesh loop at a time. You must consider adjacent mesh loop if necessary. Input the equation for the mesh loop highlighted in blue



Please enter your equation here

ERROR - Rule 21 violated: Variable name i4 is not consistent with the problem. Make sure to write meaningful equations

Figure 4. *eTutor* error message example.

If the equation is wrong, *eTutor* will provide information about the nature of the error as illustrated in Fig. 4. Another feature in the *eTutor* tool is that it provides multiple step instructions. The *step instruction box* will look for a better explanation of the problem if the step is missed. Each step contains its own personalized multiple step instructions in case the equation was missed because of lack of understanding regarding what to do or how to approach the problem.

After the 5<sup>th</sup> failed attempt, *eTutor* will ask if you would like to see the answer as shown in Fig. 5.

You have 5 mistakes until now, would you like to see how can we solve this circuit?

Figure 5. *eTutor* approaches the user after the 5<sup>th</sup> failed attempt.



## V. Experimental Results

A survey for the Beta version of the *eTutor* was conducted for students of different majors from the Principle in Electrical Engineering (EGN 3373) class at the University of Central Florida, and results were analyzed to measure the students' feedback about the Tutor-Me Module. 77.8% of the students believe that the *eTutor* is a good tool for improving the understanding of the concepts in the class, while 18.5% think that the *eTutor* tool was not the only reason behind the understanding of the concepts but the Module is good and user friendly, and 3.7% reported that the tool was not effective for them. Fig. 7 reports the survey results. Most answers came positive, and the students expressed their willingness to use this tool for all their courses.

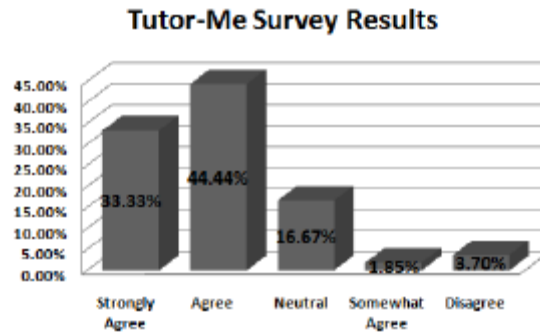


Figure 7. Survey results

## VI. Conclusion

The MeLearning project will take a major leap in engineering education and will facilitate learning at a pace specific to the learner without the constraints of a fixed time span – semester or quarter, currently specified in our curricula. This paper, addresses the TechEBook Tutor-Me Module in particular. It presents a new electronic, interactive and adaptive method to maximize the students learning experience, in their self learning process and increase their understanding in any given topic. The main purpose of the *eTutor* technique is to provide a well defined step-by-step interactive problem solving that will help in testing the user understanding of key concepts in each main section presented by the TechEBook. The overall assessment of the class, who tried the *eTutor*, resulted in an average score of 77.8% for students who believed that the *eTutor* technique was beneficial and 3.7% for non effectiveness of the tool, the rest were neutral. Most students welcomed the new tool, which reflected the importance of these on-line modules.

## VII. References

- [1] Issa Batarseh, Ghaith Haddad, Rawad Haddad and Rashad Oreifij, 'Interactive Electronic Book Operating Systems And Methods,' United States Patent 20080222552.
- [2] Ruba A. Amarin, Feras Batarseh and Issa Batarseh, 'Adaptive electronic quizzing method for introductory electrical circuit course', International Journal of Online Engineering (iJOE), vol. 5, No 3, 2009.
- [3] Ruba A. Amarin, Kalpathy B. Sundaram, and Arthur Weeks, 'Importance of practical relevance and design modules in electrical circuits education', IEEE EDUCON Education Engineering Conference, April 2011.
- [4] Ghaith Haddad, Gustavo Gamboa and Issa Batarseh, 'Interactive electrical circuit tutoring tool. eTutor,' ASEE Southeast Section Conference, Memphis, TN, April 2008.



## **Development of a Drag Coefficient Laboratory via Capstone Design**

Mir Atiqullah

Associate Professor, Mechanical Engineering Technology.  
Southern Polytechnic State University  
Marietta, GA 30060

Norman Russell

Associate Professor, Mechanical Engineering Technology.  
Southern Polytechnic State University  
Marietta, GA 30060

### **MIR ATIQULLAH**

PhD in Mechanical engineering from Purdue University in 1996.

Research areas include computational optimization in design, genetic algorithm and simulated annealing, parallel supercomputing, engineering education.

Teaching a broad range of engineering courses including machine design, materials science, engineering mechanics, manufacturing, and fluid mechanics.

Professional experiences include 10 years of industrial and 17 years of teaching engineering and technology areas.

### **NORMAN RUSSELL**

PhD in Chemical Engineering from Institute of Paper Chemistry in 1965.

PE from Alabama.

Research areas include paper chemistry, engineering education.

Teaching a broad range of engineering courses including thermodynamics, fluid mechanics, and laboratory courses.

Has 29 years of industrial and 17 years of teaching experience.

## **Development of a Drag Coefficient Laboratory via Capstone Design**

Abstract:

The concept of aerodynamic drag is fundamental to fluid dynamics. A drag force experienced by an object is related to drag coefficient, a dimensionless parameter. The effect of important factors, geometric shape of the object, air properties, and wind speed on aerodynamic drag is traditionally demonstrated in a Wind Tunnel.

In a standard fluid dynamics laboratory, the relationship between object shape and drag coefficient is vividly illustrated using a few distinctly different solid shapes: flat disc, hemisphere, sphere, and teardrop. The effect of stream lining an object shape is clearly demonstrated. In order to make the laboratory experience more related to real-world and more interesting to students, it was proposed to use model cars in wind tunnel in addition to the basic shapes. Three automobile models were selected: Ford Model T, Chevrolet El Camino, and 1970's Porsche. The models represent three distinct levels of stream lining. A group of senior students in the capstone Machine Design class was assigned to develop CAD models as well as scale model prototypes of these cars. Using the CAD model and a three-dimensional printer, physical scale models of the three autos were produced. A mounting technique was designed to secure the models in the wind tunnel. Flow simulation in Computational Fluid Dynamics (CFD) environment was employed to predict the Drag coefficient of each model. The predicted values fell within expected range of published values.

In the design phase the models were smooth; so the surfaces were finished to mimic the design condition. The models were tested in the wind tunnel at various wind speeds. Air temperature was monitored. Model frontal areas were available from the CAD design. Recorded data were used to calculate drag coefficients for comparison with predicted CFD

values. Percent error between predicted and experimental values ranged from 4.65% to 9.52%.

The whole process of developing CAD models, fluid dynamics simulation, rapid prototyping, wind tunnel testing and drag coefficient comparison generated in depth understanding and interest about real world fluid dynamics and especially drag.

The design process and elements will be presented to students in future fluids labs, and students will experiment with drag coefficients for the models to foster more interest and understanding in fluid dynamics and drag.

## Introduction

Drag coefficient<sup>1,2</sup> is a characteristic value of a solid object moving in a fluid such as an airplane flying or a car cruising. It could be also be effect of fluid flowing over or around a stationary object like a building or a sail or a wind turbine. It is a measure of the resistive force that is developed due to geometry, orientation of the object and of course velocity and characteristics of the fluid such as density and implicitly viscosity. The drag coefficient consideration is very important in reducing drag in automobiles. For an average vehicle about 50-60% of power is used to overcome the aerodynamic effects to cruise on highway. Of course at low speeds it is the rolling friction of tires that consumes most power. A streamlined vehicle shape that generates low drag force is very important to get better fuel economy of vehicles at cruising speeds. The drag force varies directly as the square of the relative speed, given everything constant, such as geometry, orientation,, flow direction, object size, fluid density and viscosity. The equation for drag force  $F_d$  is given in equation 1 below,

$$F_d = -\frac{\rho v^2 C_d A}{2} \quad (1)$$

Where,

$\rho$  is the density of the fluid,

$v$  is the relative velocity,

and  $A$  is the reference area.

It is important to note that the reference area for vehicles would be the frontal projected area. For other objects it could be the planform area such as that for an airfoil and it is the wetted area for a submerged object in flowing liquid.

The characteristic drag coefficient  $C_d$  can thus be calculated by equation 2, as

$$C_d = \frac{2F_d}{\rho v^2 A} \quad (2)$$

It is a dimensionless quantity and thus characteristics of the object in question.

If the fluid is compressible, such as air, the drag force is dependent on the Mach number  $M=V/c$ , where  $V$  is the relative speed and  $c$  is the speed of sound or wave propagation through that medium. For automobiles this Mach number factor is negligible because of low speeds relative to that of sound and can be ignored.

### The Design Process

The capstone design project is taught in combination with the Machine Design<sup>3</sup> class. While the credit hour and time allocated for the project is not at par with the standard capstone class, the faculty and the design groups take the extra time and puts in extra effort in the project. This is the final opportunity for the students to apply their science, technology, engineering as well as mathematics (STEM) background in a project for which they will get credit while they enjoy the satisfaction of solving an engineering problem and demonstrate it.

The project is approached in stages as follows:

1. Problem statement from the customer or sponsor.
2. Design statement developed by the design group.
3. Customer requirements provided by the customer or sponsor. It is list of requirements and functionality that is expected from the solution or product. These requirements are

mostly non numerical but some could be measurable, if the customer so specified.

Customer may also specify a separate 'wish list' that would be nice to achieve but not a condition of successful design.

4. Design Specification developed by the design group. This is in response to the customer requirements, fulfilling each and every item of the customer requirement list. These are mostly measurable outcomes or performance indices of the solution or product. It could be comparative as well in some appropriate situation.
5. Conceptual solutions developed by individual team members or as a group or sub-group. Often brain storming sessions are arranged to generate ideas and solutions.
6. Concept finalization and selection based on conceptual solutions developed, often combining ideas.
7. Embodiment design. This stage is the reign of engineering calculation, analyses and simulation for shape, size, feature, fit, assembly, materials, recycling etc.
8. Prototyping of the final design. This stage is to demonstrate, by using a prototype of the final design, that the final design meets the design specification, and thus meets the customer requirements. Most of the times our design groups are expected to develop a working prototype, although for complex or large projects a convincing simulation of the functioning is considered a successful design.
9. Documentation and communication:
  - a. Maintains a design activity log book.
  - b. Develops, updates, and follows a Gantt Chart.
  - c. Midterm oral project review, evaluated by students and faculty
  - d. Final presentation, evaluated by student peers and faculty.
  - e. Final report
  - f. Design poster.

## Procedure

One of the authors who usually teaches Fluid Mechanics<sup>4</sup> labs and always asked for student input at the conclusion of the course. Students' feedback indicated the interest of a lab that dealt with Drag Coefficient that is applicable in the real world. For some time students

conducted the a drag coefficient lab using simple geometric shapes, such as a sphere, a hemisphere, a flat circular aluminum plate, and a tear drop shaped object that was generated by the rapid prototyping machine. These simple shapes gave students an understanding of how wind tunnel testing is conducted but are not as interesting and relevant as testing real world object such as model cars and possibly airplane models. The instructor, one of the coauthors, assigned the task of developing the drag lab to one of the capstone design groups. The task was divided into the following steps:

- Select three car models with maximum varying streamlines shapes.
- Acquire the selected model toy cars, if possible.
- Measure or estimate the dimensions and develop CAD solid models using SolidWorks<sup>5</sup>.
- Simulate flow over these models using the Computational Fluid Dynamics software.
- Determine average drag coefficient for each model.
- Generate scale models of these CAD models using the departmental rapid prototyper<sup>6</sup>.
- Test these scale models in the wind tunnel at various speeds as used in CFD simulation.
- Compare the results and the relative Drag coefficients.

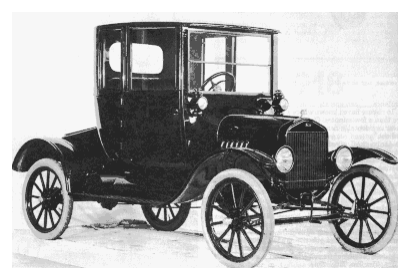
Three cars of differing eras and models were chosen. These were 1970's Ford Model T, 1970's Porsche 917, and 1979 Chevrolet El Camino pickup truck. These cars shown in figure 1.



1970's Porsche 917



1979 Chevrolet El Camino



1920'S Ford Model T

Figure 1: Model cars chosen for drag coefficient lab development.

The solid models were developed for each of these models which are shown in Figure 2. These CAD models were the bases of both computational fluid dynamics simulation as well as generating solid prototypes on the prototyping machine, thanks to the integrated software package for easy data transfer between models.

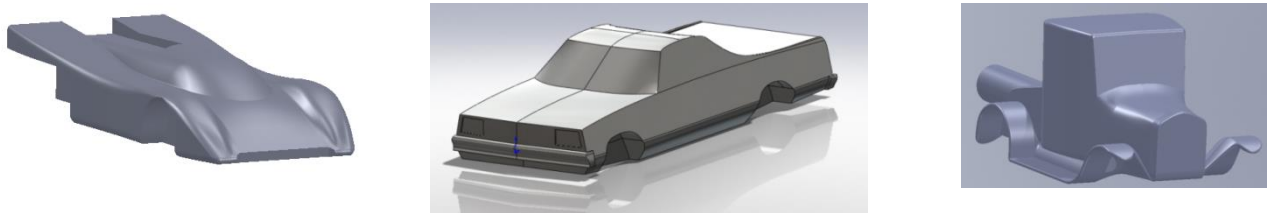
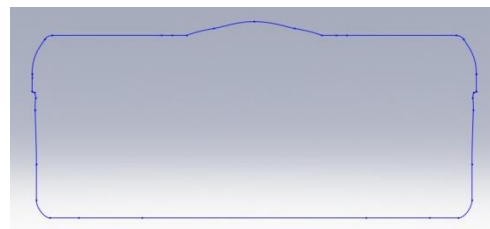


Figure 2: CAD models of (from left) Porsche, El Camino, and Model T.

Computational Fluid Dynamics (CFD), tool is integrated within the SolidWorks software package and allows the simulation of flow over solids just as in a wind tunnel. All the input parameters such as velocity, temperature, area, etc. to solve an equation for drag coefficient are inputs to the simulation. The characteristic area used, in our case the frontal area, came from the frontal area of each model, easily derived from the cad model. The frontal area is a silhouette of the car looking at it from the front as shown in figure3, in this case for the



Porsche model.

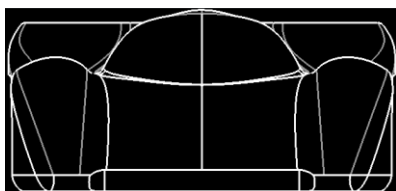


Figure 3: Frontal area determination from CAD models

Then the CFD simulation was performed for each CAD model and respective drag coefficient was calculated. Next step was the wind tunnel testing. For this stage scale models of the cars were needed, for which the 3D printer (rapid prototype) was used. The 3D printer works like a computer controlled (CNC) hot glue gun that builds an object in successive layers from bottom up. It uses two different materials; one for building the model and the other for supporting overhanging sections. The support materials are easily removable leaving only the model. Depending on the geometry of the object, build orientation, and resolution of the 3D printer, the model surfaces are not smooth like a finished product. However a little hand polishing with common abrasive cloth was enough to achieve sufficient surface smoothness that would not cause high surface friction. The hand finished plastic scale models are shown in figure 4.



Figure 4: 3D printed scale models. The wheels are excluded for simplicity.

## Testing and results

The plastic solid models from the 3d printer were then mounted using aluminum sleeves inserted from the back and horizontal holders inside the wind tunnel. Tests were then conducted on each car using an AEROLAB wind tunnel. Since drag coefficient depends on the speed, all simulation and wind tunnels tests were done for a speed of 30 mph. Averages of several tests are shown in table 1. Drag coefficient data from CFD simulation is also tabulated and the deviations are calculated as percentage of CFD simulation values. While the  $C_d$  value for Porsche in wind tunnel testing was slightly higher than that from CFD simulation, it was somewhat lower for the other two models. In all cases the deviation was less than 10%.



These results were not only close to each other in both methods, but variations were a combination of positive and negative. This may indicate that the results obtained are close to ideal ones.

Of course more testing is needed while making sure each test is performed in identical conditions. Especially wind tunnel test parameters and mounting must be closely monitored and

Table 1: Comparison of drag coefficients from CFD simulation and wind tunnel testing.

<b>Car</b>	<b>CFD simulation</b>	<b>Wind Tunnel</b>	<b>Percent deviation (%)</b>
<b>Porsche</b>	0.43	0.45	4.65
<b>El Camino</b>	0.21	0.19	-9.52
<b>Model T</b>	0.69	0.63	-8.70

controlled for consistency. Furthermore scale model building and surface preparation experience were invaluable experience as part of the experimental process.

## Conclusion

The goal of developing a laboratory exercise for teaching drag coefficient was successful. A capstone design group was employed to develop the CAD, CFD and scale models and perform the tests under the supervision of the authors. It fulfilled the wish of the design group to study the car models for drag behavior. It is expected that when a laboratory exercise will be fully developed and conducted this fall semester, it will be one of the attractive labs students will do. The 'Drag Lab' would include theoretical background study as well as computational (CFD) simulation and physical model testing in a wind tunnel. The enthusiasm of the design group members was remarkable knowing their efforts and study will benefit future students like themselves. This lab exercise will also remind the future students of the level of study and efforts that went into its development by peer students like themselves. The addition of this lab in fluid mechanics lab syllabus

will serve the objective of bringing real world problems into engineering and technology classrooms.

## Bibliography

1. Chadwick, S. G. and Hsske, S. J. The drag coefficient of tennis balls. In: SUBIC, A. and HAAKE, S., (eds.) *Engineering of sport - research development and innovation*. Blackwell, pp-169-176, 2000.
2. C. Norberg, "Flow around a Circular Cylinder:Aspects of Fluctuating Lift," *Jurnal of Fluids and Structures*, V. 15, 3-4, pp 459-469, April 2001.
3. Bernard J. Hamrock, Steven R. Schmid, Jacobson, "Fundamentals of machine Elements", 2<sup>nd</sup> Ed. McGraw-Hill Higher Education, 2004. 980 pp.
4. M. Moran & H. Shapiro, "Fundamentals of Engineering Thermodynamics"; 7th Edition;.Dec. 2010, Wiley.
5. Manual and help files for the CFD simulation within SolidWorks software package.
6. Manual of the Dimension 3D printers by Stratasys.

## **Values Affirmation Essay to Mitigate Exam Anxiety and Improve Scores**

Sara A. Atwood  
Elizabethtown College

Tomás Estrada  
Elizabethtown College

### **SARA A. ATWOOD**

Sara A. Atwood is an Assistant Professor of Physics and Engineering at Elizabethtown College. She obtained her BA and MS from Dartmouth College and her PhD in mechanical engineering from the University of California at Berkeley. Her research interests include material failure in medical devices and creativity as a factor in the recruitment and retention of underrepresented undergraduates in engineering.

### **TOMÁS ESTRADA**

Tomás Estrada is an Assistant Professor of Physics and Engineering at Elizabethtown College. He obtained his BS from Universidad de Costa Rica and his MS and PhD from Notre Dame University in electrical engineering. His research interests include control systems applied to sustainability applications and enhancing introductory lab experiences for engineering undergraduates.

## Values Affirmation Essay to Mitigate Exam Anxiety and Improve Scores

### Abstract

Recent research has found that using psychological interventions can substantially improve the performance of students, particularly when they are in stereotypically underperforming groups including women in college physics courses<sup>1</sup>, black students in junior high<sup>2</sup>, and high anxiety students in high-risk testing situations.<sup>3</sup> The psychological interventions have included the following: values affirmation at one or two points during the semester in which the student reflects upon values or topics important to them to enhance their self-worth,<sup>1,2</sup> or expressive writing in which the student writes down concerns about the exam immediately before taking the test.<sup>3</sup> Based on these recently published studies, we hypothesized that in a mid-level engineering course, exam underperformers could mitigate the effect of anxiety and improve their exam scores by writing a values affirmation essay immediately prior to the exam.

Our study focused on one mid-level course (thermodynamics) within the ABET-accredited general engineering curriculum at a small (less than 2,000) regional liberal arts college. The course had an enrollment of 30 students spanning sophomores (47%), juniors (43%), and seniors (10%), including 8 women (27%). Before each of two midterm exams, the students were assigned one of two exercises to complete during the 10 minutes prior to the exam: a values affirmation prompt, or the assignment to study their notes. For the second exam, the students switched activities. At the end of each exam, students filled out a survey about their typical exam performance (self-identifying underperformers), perception of how they did on the exam, how anxious they felt during the exam, study time, some demographic information (gender, year), and an identifier code. When the exam was handed back, students filled out another survey with the same identifier and were asked about their actual grade. The resulting data were analyzed using linear regression between variables, t-tests comparing the underperforming group to the consistently performing students, and paired t-tests to compare performance for each student using the two different activities.

Writing the values affirmation essay resulted in higher exam scores for the underperforming students ( $p$ -value  $< 0.20$ ), more B's (38% vs 29%) and fewer D's and F's (20% vs 47%). Exam scores for the consistently performing students were mostly unchanged with the activities (no significant difference). Writing the essay also appeared to mitigate the effect of anxiety on exam score for all students. When studying notes, the underperformers' exam score decreased with increasing anxiety while the consistent performers' exam score increased with increasing anxiety (opposite trends). Writing the essay also brought the underperformers' anticipated grade closer to their actual grade, which was a characteristic of the consistent performers in both activities. Finally, the underperforming students rated the exam as more reflective of their understanding after writing the essay ( $p$ -value  $< 0.10$ ). These results are consistent with those reported in previous studies<sup>1-3</sup> and suggest that a psychological intervention just before an exam may help students who tend to underperform on engineering exams.

## Introduction

Recent research has found that using psychological interventions can substantially improve the performance of students, particularly when they are in stereotypically underperforming groups including women in college physics courses<sup>1</sup>, minority black students in junior high<sup>2</sup>, and high anxiety students in high-risk testing situations.<sup>3</sup> The psychological interventions have included values affirmation<sup>1,2</sup> and expressive writing.<sup>3</sup>

Values affirmation exercises involve reflecting upon values or topics important to a person, but unrelated to the task at hand, for 10-15 minutes. This is thought to enhance the person's selfworth in an environment requiring them to cope with negative stereotypes.<sup>4-5</sup> Expressive writing exercises, on the other hand, involve writing down concerns immediately prior to performing the task. Rather than focusing the person on their anxiety, expressive writing is thought to mitigate anxiety by stopping the cycle of rumination on negative outcomes.<sup>6</sup>

These psychological interventions have been applied to students taking exams in recent studies. Miyake et al.<sup>1</sup> used a values affirmation prompt in a double-blind randomized study of college students in an introductory physics class in an attempt to close the gender achievement gap. Half of the students were asked to select their most important values from a list and write about why they were personally important, while the other half selected their least important values and wrote about why they might be important to other people. The exercise was performed in the first week of the course and was repeated one week prior to the first midterm.

Striking results showed a substantially reduced difference in the overall exam scores for men and women that wrote about their values, and a letter-grade increase for those women. The gender achievement gap persisted in the control group.

In an earlier study, Cohen et al.<sup>2</sup> used values-affirmation prompts in two randomized field experiments to similarly close the minority achievement gap. Students in 7<sup>th</sup> grade were asked to reflect on personal values in structured writing assignments. After one or two exercises, the overall grades of African American minority students improved compared to a control group and to historic performance data, while European Americans grades remained unchanged. A two year follow-up recently showed that the impacts were long-term, as the minority achievement gap remained more closed for those cohorts.<sup>7</sup>

Ramirez and Beilock<sup>3</sup> used expressive writing exercises in a series of randomized laboratory and classroom studies to mitigate the effect of underperforming in a high-pressure testing situation. They found that writing about the exam specifically, as opposed to any ordinary topic, improved the scores, particularly for high anxiety students in a high-pressure exam situation. Results were consistent for two 9<sup>th</sup> grade biology cohorts, and suggest that a psychological intervention may allow all students to demonstrate their true level of understanding, without being diminished by the effects of anxiety.

Based on these recently published studies, we hypothesized that in a mid-level engineering course, serial exam underperformers could mitigate the effect of anxiety and improve their exam scores by writing a values affirmation essay immediately prior to the exam.

## Methods

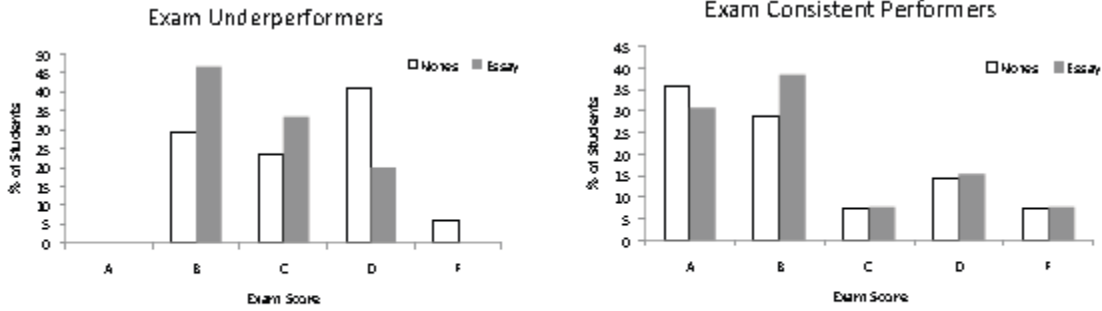
Our study focused on one mid-level course (thermodynamics) within the BET-accredited general engineering curriculum at a small (less than 2,000) regional liberal arts college. The course had an enrollment of 30 students spanning sophomores (47%), juniors (43%), and seniors (10%), including 8 women (27%).

Before each of two midterm exams, the students were assigned one of two exercises to complete during the 10 minutes prior to the exam: a values affirmation prompt, or the assignment to study their notes. For the second exam, the students switched activities. The students were ranked according to GPA by the instructors, and then randomly assigned to an activity so that each activity group had a similar average GPA. This ensured that the activity groups were relatively evenly matched in terms of typical performance. After group assignments were made, names were stripped from study materials and instructors were not aware of which students were in which groups when scoring the exams.

At the end of each exam, students filled out a survey about their typical exam performance (self-identifying underperformers), perception of how they did on the exam, how reflective was their exam performance of their understanding, how anxious they felt during the exam, study time, some demographic information (gender, year), and an identifier code. When the exam was handed back, students filled out another survey with the same identifier and were asked about their approximate actual grade. The resulting data were analyzed using linear regression between variables, t-tests comparing the underperforming group to the consistently performing students, and paired t-tests to compare performance for each student using the two different activities.

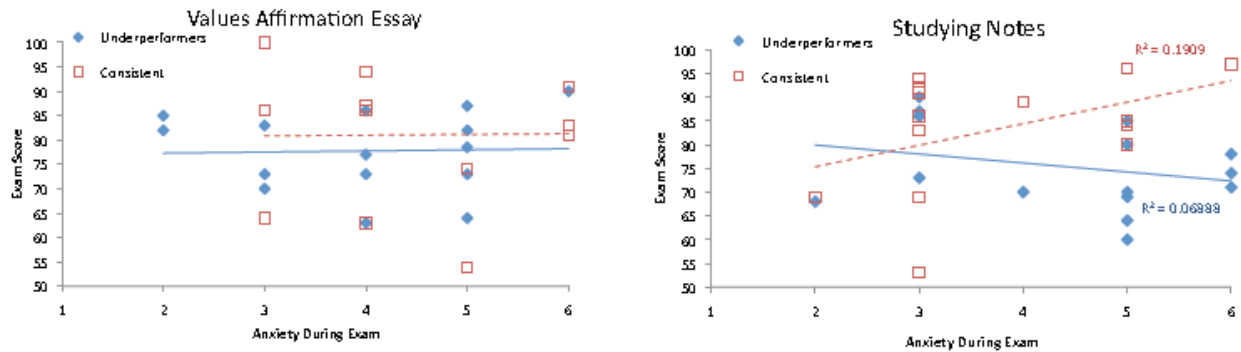
## Results and Discussion

Writing the values affirmation essay resulted in higher exam scores for the underperforming students ( $p$ -value  $< 0.20$ ), more B's (38% vs 29%) and fewer D's and F's (20% vs 47%) (Figure 1, left). Exam scores for the consistently performing students were mostly unchanged with the activities (no significant difference) (Figure 1, right).



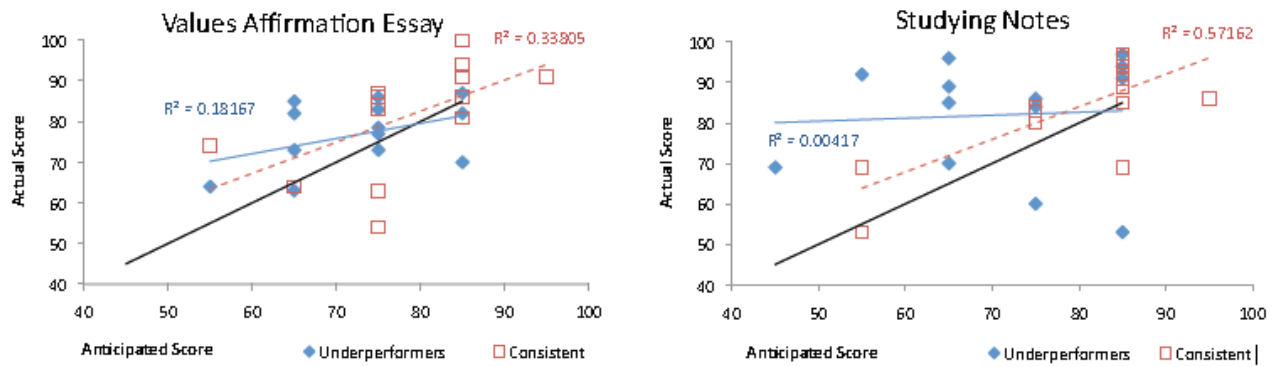
**Figure 1.** For the underperformers (left), writing the values affirmation essay resulted in more B's (38% vs 29%) and fewer D's and F's (20% vs 47%). For the consistent performers (right), exam scores were mostly unchanged.

Writing the values affirmation essay also appeared to mitigate the effect of anxiety on exam score for all students (Figure 2, left). When studying notes, the underperformers' exam score decreased with increasing anxiety while the consistent performers' exam score increased with increasing anxiety (Figure 2, right).



**Figure 2.** Students writing the values affirmation essay (left) had no relationship between anxiety during the exam and the exam score. For the control group studying notes (right), exam underperformers had a decreasing exam score with increased anxiety, while the trend was opposite for consistent performers.

Writing the essay also brought the underperformers' anticipated grade closer to their actual grade, which was a characteristic of the consistent performers in both activities (Figure 3).



**Figure 3.** For the underperformers, writing the values affirmation essay (left) brought their anticipated score closer to their actual score (solid black line is perfect agreement). Consistent performers had the characteristic of anticipating their score more accurately in both activities.

Finally, the underperforming students rated the exam as more reflective of their understanding after writing the values affirmation essay (p-value < 0.10) (Table 1). Table 1 shows the results for both overall t-tests for each group (values affirmation essay versus control studying notes) and paired t-tests for individual students. Similar trends for both the overall and paired t-tests were found. For the underperformers, the exam scores and reflectivity of the exam were statistically significantly higher after writing the values affirmation essay (p-value < 0.20) (Table 1). Interestingly, for the consistent performers, writing the values affirmation essay increased their anxiety during the exam. This may be because they were not allowed to look over their notes prior to the exam, which is the observed usual pre-exam routine for these students.

	Approximate Grade in Course	Exam Score Anticipated	Nervous During	Exam Score	Reflective
<i>Overall t-test</i>					
consistent	0.932	0.619	<b>*0.130</b>	0.858	0.658
underperformers	0.421	0.636	0.388	<b>*0.198</b>	<b>*0.092</b>
<i>Paired t-test</i>					
consistent	0.677	0.822	<b>*0.079</b>	0.884	0.793
underperformers	0.452	0.922	0.538	<b>0.327</b>	<b>*0.109</b>

**Table 1.** Results for overall t-tests for each group (values affirmation essay versus control studying notes) and paired t-tests for individual students. Similar trends for both the overall and paired t-tests were found. For the underperformers, the exam scores and reflectivity of the exam were statistically significantly higher after writing the values affirmation essay.

The outcomes that are not statistically significant are important as well. The approximate grade in the course, the anticipated exam score, and the exam score for the consistent performers were all statistically insignificant (Table 1). This suggests that the attempt to have intervention and control groups equal in ability was successful.



Furthermore, this suggests that the midterm exams were similar in their difficulty and rigor in grading.

This study has several limitations. Primarily, the size of the cohort is relatively small at 30 students. This limits the statistical power of the t-tests and linear correlations. However, trends are still apparent. Another limitation is the self-reporting on a Likert scale of nervousness during the exam and reflectivity of the exam, as well as using self-reporting to identify exam underperformers. The discrete nature of the Likert scale makes linear correlations more difficult to detect. However, given the lack of a continuous objective measure, these methods are similar to those used elsewhere.<sup>1-3</sup>

Furthermore, there may have been lingering effects from the first values affirmation activity in the students who wrote the essay first, and then switched to the control activity (studying notes) for the second midterm. Similar studies report that the intervention starting having an impact after only one or two exercises. This may be why the paired t-test for individual students in the underperformers category was not as strong a statistical result as for the overall groups (Table 1). Despite the possibility of lingering effects, the data show that underperformers scored significantly higher immediately after writing the values affirmation essay.

The control activity is also substantially different than writing a “dummy” essay as other studies have done.<sup>1</sup> We think this is a unique strength of this study, in that we are implementing the psychological intervention in a more realistic classroom setting where students will typically study their notes in the few minutes before the exam is handed out. Another strength of this study is its implementation in an engineering curriculum. Engineering courses often require strong performance on challenging exams. However, students with a variety of talents often make excellent engineers (communication skills, seeing the big picture in a company, innovation in problem solving, hands-on skills). These students may be overly penalized if they internalize their poor performance on exams due to anxiety. Furthermore, the engineering field may be penalized if we lose these talented students because they have exam anxiety that negatively impacts their performance.

Our results are consistent with those reported in previous studies<sup>1-3</sup> and suggest that a psychological intervention, such as a values affirmation essay, just before an exam may help students who tend to underperform on engineering exams.

## References

1. Miyake et al., *Science*. 2010 Nov 26; 330 (6008): 1234-1237.
2. Cohen et al., *Science*. 2006; 313: 1307.
3. Ramirez et al., *Science*. 2011 Jan 14; 331 (6014): 211-213.
4. Steele, C.M., *Advances in Experimental Social Psychology*, L. Berkowitz, Ed. Academic Press, New York, 1988, 261-302.
5. Cohen, G.L., Garcia, J. *Curr. Dir. Psychol. Sci.* 2008; 17: 365.
6. Smyth, L.M., *J. Consult. Clin. Psychol.* 1998; 66: 164.
7. Cohen et al., *Science*. 2009 Apr 17; 324 (5925): 400-403.

## **Introduction to the EMC/EMI Education into the Engineering Technology (ET) Curriculum through Course Assignments and Projects**

Radian Belu, PhD  
Scholl of Technology  
Drexel University  
[Radian.Belu@drexel.edu](mailto:Radian.Belu@drexel.edu)

### RADIAN BELU

Dr. Radian Belu is Assistant Professor within the Engineering Technology (ET) program - Drexel University, Philadelphia, USA. He holds the second position as Research Assistant Professor at Desert Research Institute – Renewable Energy Center, Reno, Nevada. Before joining the Drexel University Dr. Belu held faculty and research positions at universities and research institutes in Romania, Canada and United States. He also worked for several years in industry as a project manager and senior consultant. He has taught and developed undergraduate and graduate courses in electronics, power systems, control and power electronics, electric machines, instrumentation, radar and remote sensing, numerical methods and data analysis, space and atmosphere physics, and physics. His research interests included power system stability, control and protection, renewable energy system analysis, assessment and design, power electronics and electric machines for wind energy conversion, radar and remote sensing, wave and turbulence simulation, measurement and modeling, numerical modeling, electromagnetic compatibility and engineering education. During his career Dr. Belu published several papers in referred journals and in conference proceedings in his areas of the research interests. He has also been PI or co-PI for various research projects United States and abroad in power systems analysis and protection, load and energy demand forecasting and analysis, renewable energy analysis, assessment and design, turbulence and wave propagation, radar and remote sensing, instrumentation, atmosphere physics, electromagnetic compatibility, and engineering education.

# **Introduction to the EMC/EMI Education into the Engineering Technology (ET) Curriculum through Course Assignments and Projects**

## **Abstract**

Modern electronic and electrical systems engineering requires understanding of several core topics that include circuit analysis, signal processing, digital/analog electronics, control theory and electromagnetics. Compact electronic systems working at higher frequency ranges are increasingly emerging in a variety of applications. On the other hand the system design skills are requested more frequently in electrical engineering job descriptions. Electromagnetic Interference (EMI) and Electromagnetic Compatibility (EMC) issues have taken an important role in the electrical/electronic product design. With increasing use of power switching electronics, computers, variable speed drives, cellular phones and electronic commerce and Internet, it is essential that all these devices operate satisfactorily in its electromagnetic environment and, also, not interfere with other electronic equipment. EMC became an important part of any studies in electrical, electronic or computer engineering. EMC deals with electromagnetic interference (EMI) and prevention of it in electronic or electrical systems. The topic is of critical importance in both electrical engineering (EE) and electrical engineering technology (EET) education, EMC being an integral part of the design to ensure the operability and competitiveness of the product as well as its compliance with government regulations for consumers' safety. Because of this trend of imposing EMC regulations on electronic products, EMC design has been gaining more attention than before in the industries. Unfortunately, in most universities, very little or none has been taught at the undergraduate level in the area of EMC compliance and design. EMC is not a subject which features very prominently amongst the many those today undergraduate students have to cope with. Due to the lack of EMC knowledge, these future engineers and technologists, when they graduate and enter the industry, will have to learn the EMC design technique through the painful trial-and-error process. Not only that, the companies that hire these engineers also suffered from higher design cost and unnecessary production delays, which are crucial competing factors in the today markets. The significance of the subject though and its impact on all facets of electrical and electronic engineering make it necessary to introduce it into the EE or EET curriculum. It is argued in this paper that it is best to teach EMC as an integrated element within almost all undergraduate courses because of its generality. Any reluctance on the part of students to tackle additional electromagnetics is thereby countered while at the same time a wealth of practical examples exists to reinforce fundamental theory. While this paper advocates the needs to introduce EMC/EMI topics all over the curriculum, through course assignments and projects, and in the same time argued on the necessity of a future course on EMC at undergraduate level in any EE or EET programs. In addition, it discusses and outlines the essential contents of such a course, which can be taken by EE and EET students with very basic knowledge of electromagnetics. The EMC course can also be beneficial for non-electrical major students. The author also discusses various issues and methodologies used during the projects' development and the lessons' learned.

## **1. Introduction**

With the desire for constantly increasing speeds from today's electronic circuits, the need for an understanding of the basic concepts of EMC becomes more critical for graduates of electrical engineering. Today's digital and analog circuits often operate at frequencies that are considered

to be the part of the microwave spectrum. Additionally, with the increase of wireless communications and networking, and the low power devices that make this possible, and non-metallic enclosures the possibilities of an engineer having to deal with unwanted electromagnetic interference between electronic systems grow greater each day. Now the EMC has been an integral part of electronic design to ensure its operability and competitiveness of the product as well as its compliance with government regulations for consumers' safety. Taken this into the account the EMC and signal integrity (SI) have become pervasive design issues in high-speed design<sup>2-5, 10</sup>. The EMC subject may be one of important areas for research in electronics and the specialists in these fields are badly needed in the industry. However, this breed of trained engineers is still rarely found in industries or even in research institutions. To top it all, the importance of the subject is still not fully understood by the industries and the design firms as a vital content for maintaining the quality aspects and competitive edge in the context of their products. It is still heartening to note that EMC problems are tackled generally in our context as "after thought" by the professional electronics designers and not by trained EMC experts. The design of high-speed digital systems, wireless devices, mixed signal systems, and handheld devices each point to the need for more graduates who are familiar with EMC practice. However, despite of the increasing importance of the EMC, many programs do not offer a course in EMC or include relevant EMC topics into their curriculum. Those that are interested in teaching such a course often do not know where or how to begin such an endeavor. Also, there is a reluctance to add one more class to an already crowded curriculum since there is a fear that something else will have to be eliminated, or that there will be an additional drain on ever decreasing resources. The EMC topic is of critical importance in EE and EET education. Taken this into account, the EMC education needs to be updated accordingly while being emphasized into curricula.

Modern electronic systems engineering requires understanding of several core topics that include circuit analysis, signal processing, digital/analog electronics, and electromagnetic fields. In fact, the latter subject has gained a renewed significance in engineering education, as electronic systems become more integrated, operate at higher frequencies and switch with faster speeds. Compact electronic systems are increasingly emerging in a variety of applications and system design skills are requested more frequently in engineering job descriptions. However, the EMC is not a subject which features very prominently amongst the many that today's undergraduate students in EE or EET have to cope with. In fact it would probably be true to say that very few of them have actually a clear idea of these topics! This is sadly even the case amongst some of their instructors. Industry, however, has been made painfully aware of the subject's existence in the past, when the passage into laws and regulations of the IEC legislation on EMC<sup>2,5</sup>. There is now a grow realization amongst industrial community that there is a need for appropriate education in the subject, at all levels of employee. This paper addresses the problems of how EMC might be taught to ET undergraduates given that they will be the engineers of the immediate future who will have to implement these new provisions. It is argued that, at this level, EMC probably best taught as an integrated topic within the many that the student has to absorb, rather than as yet another new "flavor of the month" within an already overloaded curriculum.

The very rapid pace at which developments take place within electrical engineering fields, particularly in the electronics has meant that new topics are introduced frequently into curricula, usually at the end of the program ("final" year). In time, as subjects mature, it is not unknown for yesterday's cutting-edge activity soon to be relegated to an earlier year of study as the topic

matures and is seen to be "fundamental" to the knowledge base of the modern engineer. This injection of new material obviously puts everything else under considerable pressure and inevitably some of the really "mature" subjects are either allocated less time, or worse, are dropped all together. One significant example is Electromagnetics. The fact that a subject which literally underpins the rest of electrical engineering can be discarded from curricula is a cause for great concern. However, it is not our intention here to dwell here on this matter. Hopefully force of circumstance and undoubted pressure from industry will change this state of affairs. However, the question to be answered is how best to teach EMC to undergraduates given all the factors outlined above. A scheme which has already shown some evidence of success will be presented here. Its underlying philosophy is that EMC is not a subject in its own right; it is the art and science of the application of fundamental principles embodying virtually ALL the materials that an undergraduate has studied but has not yet learnt! One of the problems which have always faced the engineering educator is compartmentalization where the links and common areas between subjects are not appreciated and so each is studied in isolation and no overall view emerges. EMC, probably more than any other topic, lends itself ideally to breaking down these barriers because it effectively knows no frequency limits, it is not "device-dependent", it is not specifically related to anyone area of specialization and it requires the broadest possible appreciation of the underlying science in order to be achieved.

This paper details the approach used to incorporate EMC into an electrical engineering curriculum. Briefly covered are the efforts required to embed the EMC/EMI concepts into the curricula and in starting such a course at the author's university, including the steps involved in accumulating the necessary resources, tailoring the materials to the local needs and implementing them at the proposed level. The aspects of developing materials that are appropriate for both the depth and breadth approach is also covered.

## **2. Embedding EMC into the ET curriculum and the development of an EMC course**

It is important to keep in mind that a course in EMC is not standalone but builds on existing electrical and electronics engineering programs as a whole. EMC/EMI concepts and principles can be highlighted with examples from other courses e.g. analog/digital electronics, power electronics, mobile communication, microprocessors, VLSI and digital design, etc. Although various concepts of EMI/EMC can also be incorporated in various courses, but a dedicated EMC course would be of many benefits where various issues and problems can be discussed in a more integrated and coherent way. An EMC course should concentrate on the art and science of the application of fundamental principles in a systematic and coherent way. An undergraduate EMC course should enable students to master a systemic approach to the EMC problems, enabling them to identify, localize and define EMI problem at the design stage<sup>10</sup>. In addition this course should enable students to predict EMI through analysis and modeling of the EMI generators, receptors and paths.

EMC education tends to have special characteristics, which are best understood by the students trained by instructors having bias and aptitude for EMC design and analysis. For a dedicated EMC course the background required for a student would be the EMC/EMI concepts, which are indirectly taught in the undergraduate subjects on a Power Electronics, Digital and Analog Circuits, Antenna Design, Electromagnetic Fields, and Microwave Engineering. In addition to

these, students should be aware of various examples given by the teachers in the above courses, for examples when discussing reflection interfaces, references may be made of the shielding effectiveness of various materials. Adding an EMC class to an already packed curriculum is not an easy task and hard choices are necessary. Most EMC classes are offered at graduate level or as senior electives for electrical engineering students<sup>6-8</sup>. Moreover, these courses often require as prerequisite one or two semesters/quarters of electromagnetics. Over the years in many programs the electromagnetics has been reduced to one semester<sup>15</sup> or even be phased out in others, especially the EET ones. However, making even a one-term electromagnetics course prerequisite for an EMC course would likely still present scheduling difficulties for many programs. When adding a course to the curriculum, it is desirable to add "integrative" courses. These are courses that tie together concepts from several subject matter areas, as well as providing opportunities for understanding the requirements and tradeoffs of good engineering design. The realization that a well-designed EMC course is just such a class that incorporates and integrates much of the content of the typical junior/senior level EE or EET curriculum helps provide the incentive to teach such a course, especially since a properly constructed EMC course closely parallels the many requirements that form the ABET accreditation<sup>1</sup> approach that came into existence in the 2000 time frame. Because of this strong correlation, an EMC course can be considered as a "capstone" course; having both math/science/engineering aspects as well as strong design aspects. Still, due to program requirements, scheduling issues and student interest, there will be many who will not have the desire or opportunity to take such a course, since it is usually taught at the senior/beginning graduate student level.

Because of the need for a basic understanding of the EMC concepts to be in the graduating EE and EET student's "toolbox," it is desirable to use a two-pronged approach when introducing EMC into a curriculum. To do this, the idea of introducing EMC into the curriculum in depth and in breadth should be considered. However, it was often been argued that EMC should not be taught to undergraduates as a separate subject but rather should be included within the overall structure of a course, in much the same way as design is best "taught"<sup>6-8</sup>. By spreading the subject throughout the curriculum in each year of study the pitfalls associated with the compartmentalization referred to above can best be avoided. If EMC is seen to be a specialized topic then it would most likely only be offered in the final year as an optional subject, to be chosen only by those students who have an "interest" in it. Few would naturally do so. In reality the implications of interference between systems and the similar lack of immunity to its effects mean that no engineer can escape from the consequences of electromagnetic incompatibility. It therefore is of paramount importance that all students be made aware of its pervasiveness and be able to apply basic engineering principles in order to achieve compatibility between systems. EMC therefore becomes integrated into the complete structure of an undergraduate course from first until final year. In each of those years of study it should be used to provide examples to illustrate basic principles, as these are developed. In this way much of the mystique which surrounds the subject and the perception that it is a "black art" can be laid to rest and the subject can be put clearly into the context of the studied materials. Ideally an engineering course should be developing the twin skills of analysis and synthesis in equal measure. It is usually agreed though that the former is considerably easier to teach. In practice, it is the latter which distinguishes engineering from "science": this ability to produce a "well-engineered" solution, in the broadest possible meaning of that phrase.

In my opinion the designing for and EMC course would be an undergraduate final year core course, which is required to be broad and comprehensive on many technical aspects of EMC/EMI. For examples the included topics in this course are: the Electromagnetic Environment, Emission and Susceptibility, Coupling Mechanisms, Shielding, Grounding, Filtering, Bonding, Signal Spectra, Commercial and Government Specifications, EMC Test and Measurement, Modeling and Prediction, Design and Practice. In addition to the EE or EET students, this course may attract candidates from local industries and other departments who are accumulating course credits for their degrees. Indeed, it is desirable that one of the most important segments of the course should include those who are working in the industries and they have specialized knowledge and experience and may be encouraged to make direct contribution to the course by presenting a project seminar on the subjects of their expertise. The proposed course material will be based on three books and a monograph<sup>10-12,14</sup>.

### **3. Teaching and Learning Methodologies**

The students are given the essential fundamental of EMC in a traditional lecturer mode for the most part of the quarter. The lecturers cover fundamentals and various topical issues in EMC. The students are encouraged to use non-traditional sources of material e.g. worldwide web, on-line catalogues and other latest literature. The students are required to present and submit formal reports and presentation on one EMC topic. In addition every 4-5 students are required to design an experiment (case study) to highlight one or more aspects of EMI in a practical situation. The students are required to attend the presentations. It assists them to learn various topics in a short period of time and, also, get familiarized with free on-line resources. It will be an interesting learning experience for students and achieved the following goals:

- Enhanced report writing and presentation skills
- Introduction to Electromagnetic compatibility; History and examples;
- Electrical dimensions, EMC units
- Learning the subject materials in short period. This aspect is attractive due to time pressure on other subjects
- Use of worldwide web for educational purposes
- Knowledge of latest test and measurement techniques
- Familiarity and knowledge of various national and international standards on EMC
- Familiarity with the analysis approach to EMC problems
- Learning how to work in a team (time management, task allocation, tank thinking, etc ... )

As most graduate engineers may not be working as design engineers, but they are expected to be familiar with latest EMC issues and hence need to know the resources, techniques, and other requirements<sup>13</sup>.

#### **3.1 EMC Course Content**

It is important to keep in mind that a course in EMC is not standalone but builds on existing electrical or electronics engineering programs as a whole. EMC concepts and principles can be highlighted with examples from other courses. A dedicated EMC course would be of many benefits where various issues and problems can be discussed in a more integrated and coherent

way. An EMC course should concentrate on the art and science of the application of fundamental principles, which an undergraduate engineering student has already studied but has not, yet, applied the knowledge in a systematic and coherent way. An undergraduate EMC course should enable engineers to master an analysis approach to EMC problems. This approach will enable them to identify, localize and define EMI problem at the design stage. In addition this course should enable engineers to predict EMI through modeling of the EMI generators, receptors and paths. Because of the inter-disciplinary nature of EMC unit, requiring knowledge in applied electromagnetics, circuits, and information techniques. There was a little choice but to introduce this unit at the last stage of any electrical engineering or electrical engineering technology program. The duration is one semester/quarter of the program when students have covered a large selection of topics in other units. The quarter consists of 10 weeks, while two weeks are dedicated to formal presentation by students and exams. Students will have full access to the laboratory in order to perform basic testing activities. The EMC course content is, as follows:

1. Introduction to EMC
2. Conducted and Radiated Structures
3. EMC Requirements for Electronic Systems
4. Non-ideal Behavior of Electrical Components
5. Signal Spectra; Signal Integrity
6. Radiated Emissions and Susceptibility
7. Conducted Emissions and Susceptibility
8. Crosstalk and EMC Coupling
9. Shielding and Grounding
10. Electronic Discharge
11. System Design for EMC
12. EMC Measurements

### **3.2 Design Projects, Project- and Problem-Based Learning**

Highly qualified EMC engineers are required not only to solve problems but also organize EMC management and EMC related products and systems development for practical applications in industry. It is necessary to provide that the university activities, in-house courses for the coordination between university and industry are significant for the education of engineering in EMC. From the author previous experience, the classroom-study of EMC is usually not enough to ensure students having the real capability of solving practical EMI noise problems, so we decided to offer an opportunity through graduation and power electronics projects that the students become familiar through design to the EMC/EMI concepts and practice. In order to involve the student in real world EMC/EMI applications, some projects are included in the curriculum. These projects are samples of the industry applications where the knowledge of the subject can be applied. The projects include further technical content that lies outside the subject boundaries but that is useful to improve students' motivation. A practical printed circuit board (PCB) layout project has been designed for the purpose of EMC education at the undergraduate level. Because the scope of EMC design is rather wide, the project focuses only on controlling radiated emissions from PCB with good layout practices. By giving the students two chances to do their PCB layouts, the authors have emulated a design review process similar to that in the industrial environment. Once they understand the radiation mechanism, they will challenge the validity of specific design rules used in the past rather than adopt these rules without knowing



the rationale behind them. The practical approach adopted in these projects has achieved its objective to train better electronic engineers for the industry.

In Problem- and Project-Based Learning (PBL), learning is encouraged by a problem and students learn topics when they need them during problem solving. In Project-Based learning, students also manage resources and time for project execution and work in teams<sup>1,16-18</sup>. Both Problem- and Project-Based Learning have been applied in many fields of engineering<sup>17-20</sup>. The work presented in [5] focuses on a teaching experience for power systems basics by using a pedagogical approach based on computer-mediated and problem-based learning. This presents the use of a web-based environment in the courses and technical aspects about the design of web-environment; the paper also uses a survey to appraise the experience with the new approach. The designs of curricula by using PBL for engineering programs are presented in these papers<sup>17-19</sup>. Given that the work carried out in Project-Based Learning is similar to professional performance in engineering programs, the PBL approach presented herein adopts this pedagogic strategy<sup>20,21</sup>. List of design experiments to highlight aspects of EMC/EMI in a practical situation contains:

- **1<sup>st</sup> experiment:** The aim of this experiment is to examine the effects of crosstalk on various cables and compare the EMI between various cables to show the effect of shielding on the measured radiation.
- **2<sup>nd</sup> experiment:** The aim of this experiment is to test hypotheses that relative distance and orientation between the two devices change EMI effects of the radiated emission. Since this is a radiated EMI shielding could improve or resolve the problem.
- **3<sup>rd</sup> experiment:** To investigate the nature of RFI/EMI produced by power semiconductors by investigating the interference caused in their typical circuit configuration.
- **4<sup>th</sup> experiment:** To examine the EMI as functions of output power, load characteristics, firing angle
- **5<sup>th</sup> experiment:** To illustrate the effects of using RC snubber circuits as a method of minimizing the interference effects of power semiconductors.
- **6<sup>th</sup> experiment:** To investigate the phenomenon of racing clocks, to gain an understanding into why it occurs and how to rectify the problem.

The students are also encouraged to utilize worldwide web and critically evaluate various sites and report on topical issue. It is interesting to find that much of the literature has been found in English speaking world. The students have used many resources including online and literature from professional bodies. The students have produced excellent reports on various topical issues of EMI/EMC in various fields of applications. The students have been exposed to many problems and issues, related measurement and test procedures. Some examples of industrial EMI/EMC issues are as follows: aerospace, transportation/train traction, automotive, power system and power supplies, telecommunication, variable speed drives, medical equipment, computer hardware and data communication, high frequency engineering, and ships

To enhance the hands-on experience the proposed EMC course is structured as a project based course. Students are required to analyze, design, simulate or built a completely functional system, as an end-of-term project, selected from a list proposed by the instructor or their own project with the instructor agreement of the topics. The goal of the design project is to explore and enhance students understanding of the fundamental power conversion principles, power

circuit simulation capability and hands-on demonstration of circuit prototyping. The course project is worth 25% of the course grade. Students are required to present their project output in a poster session arranged for a technical audience. They are also required to summarize the results of the design in a short report by the end of the course.

#### **4. Lessons Learned and Student Assessment**

The student reaction to the incorporation of EMC/EMI topics into our curriculum has been well received so far. In the first two academic years, over 15 students were involved in the projects from power electronics and senior design with an emphasis on the EMC design aspects. Some of the projects included a series of exercises, where the end result was the development of an EMC design specifications and procedures. The purpose of this was two-fold: to reinforce the EMC concepts, as well as give the student the opportunity to develop a computational tools that the students may use in other projects. Another type of projects implies the requirements to do a design exercise based on the EMC design competition. This allowed the students to apply the theoretical knowledge gained from the lectures to a simulated real world problem. The inclusion of the EMC topics into the power electronics and senior design projects, beginning with the academic year 2009-2010 was very well received by the students, as resulting from informal surveys conducted during the oral presentations at the end of these courses. The results from the students' feedback will be part of the course improvements and future restructurings. Similar survey will be conducted at the end of each quarter when the EMC course will be first offered.

#### **5. Conclusions**

This paper advocated the need to introduce an independent EMC course and discussed the content of such a course. In addition this paper explained the various methodologies used during the introduction of the EMC topics in our senior design and power electronics projects in our program. This paper also discussed some typical experiments and various projects to enhance the learning experience of students. The proposed EMC course builds on the students' earlier courses on calculus, circuits and signals. The content of the course covered the essential topics in EMC education with a stronger emphasis on modern system design considerations. The course introduces a wide range of topics including electric and magnetic fields, electromagnetic waves, transmission lines, antennas and radiation, coupling and shielding, parasitic effects, and susceptibility. Introduction of the EMC design aspects into the senior design and power electronics projects was received favorably by the students. The students especially liked those projects and experiments that helped them to understand how to model a field problem as a circuit problem. As one conclusion drawn from is that the EMC education needs to take advantage of the capabilities of circuit simulation tools. Complex subjects such as electromagnetic-related topics can be taught more effectively by presenting pertinent practical engineering problems. Inspection of such problems through simulations and by conducting simple experimental evaluations provides the students with practical knowledge, in-depth understanding and better retaining of the taught material. In summary, the introduction of the EMC topics and the planned addition of an EMC course in the ET program at our university have provided and will be beneficial to the program in many ways. Our students are learning an important set of design skills to take with them to the job market. Additionally, they have practiced on real world problems and seen how EMC issues affect all areas of engineering and

electronics design. Also, students have developed an appreciation of the fact that EMC is an integrative discipline, drawing from many other curriculum areas. This paper, not only advocated for the need to introduce an independent EMC course, but also discussed the content of such a course, teaching and learning methods, and the projects associated to the EMC teaching. Overall, we are pleased with the start of EMC activities here at our program and plan to expand its role here as the future unfolds. After two quarters of introduction EMC topics in the student projects, we have been received positive feedback from the student who completed the projects. They not only have achieved good results from study, but also can present some innovative idea on EMC. Thus, it is a promising way for EMC education at the undergraduate level in university.

## References

1. Engineering Accreditation Commission, "Criteria for Accrediting Engineering Programs," <http://www.abet.org/criteria.html>. (2002).
2. *U.S. Code of Federal Regulation*, Federal Communications Commission, Washington, DC.
3. "On the approximation of laws of member states relating to electromagnetic compatibility," *Official J. Eur. Communities*, May 1989.
4. *EMC Education Manual*, Education Committee, IEEE Electromagnetic Compatibility Society, July 1992.
5. EMC Society Web Page, <http://www.ewh.ieee.org/soc/emcs/>. (no date).
6. C.R. Paul, "Establishment of a university course in electromagnetic compatibility (EMC)," *IEEE Transaction on Education*, Vol. 33, pp.111-118, Feb. 1990.
7. R. M. Nelson, "EMC education at North Dakota State University," 1992 IEEE International Symposium on EMC, pp.164-167, 1992.
8. Donald D. Weiner, "EMC education at Syracuse University," 1992 IEEE International Symposium on EMC, pp.168-170, 1992.
9. *Int. Electricity Committee (IEC) CISPR 22: 1997, Information Technology Equipment—Radio Disturbance Characteristics—Limits and Methods of Measurement*.
10. D. A. Weston, *Electromagnetic Compatibility: Principles and Applications*, 2<sup>nd</sup> ed. rev and expanded, Marcel Dekker (2001).
11. C. R. Paul, *Introduction to Electromagnetic Compatibility*, John Wiley & Sons, Inc., 1992.
12. B. Kaiser, *Principles of Electromagnetic Compatibility*, 3rd Ed. Norwood, MA, Artech House 1987.
13. H. W. Ott, *Noise Reduction Techniques in Electronics Systems*, 2nd Ed. New York, Wiley, 1988.
14. G. K. Deb, *EMC Design Guide - A monograph published by G.K. Deb - Govt. of India Publications* 1990.
15. C.W. Trueman, "An electromagnetics course with EMC applications for computer engineering students," *IEEE Transaction on Education*, Vol. 33, pp. 119-128, Feb. 1990.
16. Y. Zhao and K. Y. See, "A practical approach to EMC education at the undergraduate level," *IEEE Transaction on Education*, Vol. 47, No. 4, pp. 425-429, November 2004.
17. L. R. J. Costa, et al., "Applying the Problem-Based Learning Approach to Teach Elementary Circuit Analysis," *IEEE Transactions on Educ.*, vol. 50, pp. 41-48, 2007.
18. A. A. Mota, et al., "Teaching power engineering basics using advanced web technologies and problem-based learning environment," *IEEE Transactions on Power Sys.*, vol. 19, pp. 96-103, 2004.
19. J. Macias-Guarasa, et al., "A project-based learning approach to design electronic systems curricula," *IEEE Transactions on Education*, vol. 49, pp. 389-397, 2006.
20. L. B. Gravelle and P. F. Wilson, "EMI/EMC in printed circuit boards—A literature review," *IEEE Trans. On EMC*, vol. EMC-34, pp. 109–116, May 1992.
21. M. I. Montrose, *EMC and the Printed Circuit Board: Design, Theory and Layout Made Easy*. New York, NY: IEEE Press, 1998.

**A Model University Program to Inspire Women in Science and Engineering (WISE)**

Cecelia Wright Brown, D.Eng.  
University of Baltimore  
1420 N. Charles Street  
Baltimore, MD 21201 USA  
[cwrightbrown@ubalt.edu](mailto:cwrightbrown@ubalt.edu)

Kofi Nyarko, D.Eng.  
Morgan State University  
5200 Perring Parkway  
Baltimore, MD 21251 USA  
[kofi.nyarko@morgan.edu](mailto:kofi.nyarko@morgan.edu)

Kevin Peters, PhD  
Morgan State University  
1700 E. Cold Spring Lane  
Baltimore, MD 21251 USA  
[kevin.peters@morgan.edu](mailto:kevin.peters@morgan.edu)

## A Model University Program to Inspire Women in Science and Engineering (WISE)

Cecelia Wright Brown, D.Eng.  
University of Baltimore  
1420 N. Charles Street  
Baltimore, MD 21201 USA  
[cwrightbrown@ubalt.edu](mailto:cwrightbrown@ubalt.edu)

Kofi Nyarko, D.Eng.  
Morgan State University  
5200 Perring Parkway  
Baltimore, MD 21251 USA  
[kofi.nyarko@morgan.edu](mailto:kofi.nyarko@morgan.edu)

Kevin Peters, PhD  
Morgan State University  
1700 E. Cold Spring Lane  
Baltimore, MD 21251 USA  
[kevin.peters@morgan.edu](mailto:kevin.peters@morgan.edu)

### **Abstract:**

The WISE Program was a four-week schedule of classroom instruction and academic enrichment activities designed to increase mathematics, science and reading test scores for 8<sup>th</sup> grade girls. The program was designed to cultivate science, technology, engineering and mathematics (STEM) interest in young women by increasing their learning through critical thinking and problem-solving applications to pursue engineering and science careers. The program's focus was on fifteen (15) Baltimore City School 8<sup>th</sup> grade girls who were preparing to enter Baltimore City High Schools. The intent of this program was to further the mission and goals of the funding agencies education division and inspire minority women to pursue career paths in science, mathematics, computer science, engineering, education or seek professional employment. During the four-week period the girls were engaged in exercises and activities that cultivated their research skills. The girls also showcased their research projects and technology skills through a PowerPoint presentation recapping their summer experience. The classes, workshops, seminars and presentations were conducted on the campus of a Historical Black College and University (HBCU) in Baltimore City. The coordination and instruction took place under the guidance of the Center for Excellence in Mathematics and Science Education in the School of Education (CEMSE) at the HBCU. The WISE Program was supported by funds from a federal agency grant Network Resources and Training Sites (NRTS).

### **Introduction:**

Designing an academic enrichment program for girls was prompted by the vast amount of research and anecdotal evidence that suggested girls are not traditionally encouraged to pursue careers in STEM. The mental image of a "computer geek" is rarely a female. It was anticipated that girls could be encouraged to embrace science and mathematics, thus erasing the traditional "geek" image and discouraging girls from associating high achievement with a negative image or a specific gender. According to the "Keys to Math Success," a report prepared by the Maryland Mathematics Commission [1], African American students not only have significantly lower levels of performance overall, but their performance declines slightly between fifth and eighth grade. In Tables 2 and 3 male students in Maryland scored significantly higher than females. Table 1, on the SAT mathematics assessment, mirrors the gender difference indicated in national data [2]. The 2011 Maryland School Assessment (MSA) for Baltimore City 8<sup>th</sup> grade students in mathematics showed 33.7 % of students are proficient and only 32.4% were advanced [3]. For the 2010 High School Assessment (HSA) for 10<sup>th</sup> graders, 66% of students passed the Biology assessment and 66.9% passed the Algebra assessment [4]. The scores from the MSA in mathematics and the HSA assessments in biology and algebra are described in Tables 1, 2, and 3.

**Table 1: 2010 College Bound Seniors, Maryland  
Female Mean Scores by Ethnicity**

SAT Test-Takers Who Described Themselves As:	Test-Takers		Critical Reading		Mathematics		Writing	
	Number	Pct	Mean	SD	Mean	SD	Mean	SD
American Indian or Alaska Native	81	0	480	106	457	100	466	105
Asian, Asian American, or Pacific Islander	1,780	4	546	124	580	122	558	126
Black or African American	7,734	17	432	98	413	95	430	97
Mexican or Mexican American	185	0	484	99	472	94	482	101
Puerto Rican	148	0	511	92	490	94	510	96
Other Hispanic, Latino, or Latin American	1,065	2	476	105	466	106	483	108
White	12,272	26	537	100	528	99	540	102
Other	663	1	508	114	490	117	507	117
No Response	809	2	487	144	463	134	482	142
Total	24,737	53	499	114	489	117	501	116

Source: Maryland State Report Card 2010

**Table 2: 2010 College Bound Seniors, Maryland  
Males Mean Scores by Ethnicity**

SAT Test-Takers Who Described Themselves As:	Test-Takers		Critical Reading		Mathematics		Writing	
	Number	Pct	Mean	SD	Mean	SD	Mean	SD
American Indian or Alaska Native	103	0	486	102	477	110	457	97
Asian, Asian American, or Pacific Islander	1,830	4	538	122	609	119	540	126
Black or African American	6,143	13	427	99	429	103	411	96
Mexican or Mexican American	117	0	499	108	523	118	481	105
Puerto Rican	115	0	488	117	510	105	467	105
Other Hispanic, Latino, or Latin American	832	2	485	109	506	110	474	102
White	11,193	24	541	103	567	105	523	104
Other	476	1	521	118	533	119	502	117
No Response	824	2	484	144	487	151	464	138
Total	21,633	47	503	118	525	126	487	117

Source: Maryland State Report Card 2010

**Table 3: Overall**

SAT	Test-Takers Number	Critical Reading		Mathematics		Writing		Writing Subscores			
		Mean	SD	Mean	SD	Mean	SD	Multiple Choice		Essay	
								Mean	SD	Mean	SD
Male	21,633	503	118	525	126	487	117	49.0	11.6	7.1	1.7
Female	24,737	499	114	489	117	501	116	49.7	11.6	7.5	1.5

Source: Maryland State Report Card 2003-2011

A review and analysis of the Maryland Report Card from 2003 to 2011 showed the following results: 1) the MSA scores for all grade 8<sup>th</sup> female students in the state of Maryland who were proficient or advanced in mathematics was 13.1% - 36.8% [5]; and 2) the science scores for 8<sup>th</sup> grade females who were proficient or advanced from 2008 to 2011 ranged from 24.4% - 39.7% [6]. These scores are significantly below male students in the above content areas.

The WISE program helped girls increase their ability to score higher when they took the HSA test by providing interesting and fun instruction while developing basic algebra concepts in alignment with the Maryland Learning Outcomes. In addition, the program utilized innovative instructional strategies and the girls developed a science fair topic for which they could conduct research and could be used to develop a science fair. The intent of this program was to further the mission and goals of the funding agencies education division and inspire minority women to pursue career paths in science, mathematics, computer science, engineering, education or seek professional employment.

During the four-week period the girls partook in exercises and activities to cultivate research skills. The girls showcased their research projects and technology skills through a PowerPoint presentation recapping their summer experience. The program objectives included:

1. Strengthening the mathematics and science skills using constructivist classroom methods and instructional strategies;
2. Adapting the curriculum and lesson plans according to the students' multiple intelligence strengths;
3. Providing students with instructional technology to enhance learning through the production of a web page and a power point presentations of summer research;
4. Developing problem-solving and critical thinking skills of girls through mentoring and emphasis on increased understanding of mathematical concepts and scientific inquiry;
5. Preparing students to pass placement exams in order to enroll in honors mathematics and science classes within Baltimore City High Schools;
6. Helping students understand the benefits of a mentor partnership;
7. Developing ongoing mentor/mentee relationship with university personnel and professional persons through cyber-mentoring while in High School;
8. Increasing the participants' familiarity with the scientific process through the selection of a Science Fair topic and development of project methodology for presentation; and
9. Increasing the participation and academic success rate of girls in mathematics, science and engineering.

### **Background:**

A number of state and local programs exist that target underserved students (e.g. Upward bound and Talent Search). However, few are gender specific. The need to improve indicators on the learning status of science and mathematics education of girls in middle and high school bridge programs remains a critical need. A variety of publications from the National Academy Press, public-private partnerships, Maryland State Department of Education, College Board, School Improvement in Maryland and other professional resources were reviewed. Based on literature reviews four basic themes remain evident: 1) there are inadequacies in the pre-college education of girls (this suggests that many U.S. students leave high school without adequate preparation in science and mathematics); 2) the inadequacies manifests in the lack of opportunities for girls to excel in technical careers, continuing education, and being informed citizens; 3) the problems facing the underserved population are some of the hardest issues facing educators and the least amenable to quick and easy solutions; and 4) although infrastructures are in place to identify what works in pre-K-12, higher education and the workforce, each level faces the same task of

how to identify and validate the effectiveness of programs developed to broaden the participation of women and underrepresented minorities in STEM.

### **Academic Enrichment:**

The program was divided into a morning and afternoon session. Mathematics and reading instruction occurred during the morning sessions. The afternoon sessions provided instruction in technology development, science and scientific research activities. In the first few days of the program the science teacher provided an overview of various science disciplines and current mathematics research for students to select an area of interest. The remaining daily program activities included web page design and science fair project development. The science fair project areas covered Computer Science / Mathematics, Physical Science, Biological Science, Engineering, and Earth / Environmental Science. These topics provided ample opportunity for the girls to apply mathematics and science skills they developed to their science research topics. The participants are also exposed to a higher level of learning in a subject area in which they had little or no prior experience. The students then selected topics and begin their research in developing a science fair project for exhibition during the Annual Science-Mathematics-Engineering Fair. As part of the education enrichment experience the curriculum and lesson plans were adopted according to the students' multiple intelligence strengths. The student enhancement part of the WISE Program included activities to support the following:

#### **Approaches to Learning**

**The application of visual/spatial intelligence**

**To increase the girls verbal/linguistic intelligence**

**To enhance the girl's ability to use logical/mathematical intelligence**

**Activities to promote bodily/kinesthetic intelligence**

#### **Instructional Activities**

Language Arts - By reading (metaphors and analogies), writing, understanding charts and graphs, developing a good sense of direction, manipulating images, constructing models, designing practical objects and interpreting visual images.

Speech - Cultivate public speaking skills (oral presentation of summer research at the closing reception) to think with words rather than pictures, listening to guest speakers, professionals and peer experiences, peer tutoring and teaching, appropriate use of humor, understanding the syntax and meaning of words, remembering information and analyzing language usage.

Curriculum Activities - The curriculum included activities that involved: problem solving, classifying and categorizing information, working with abstract concepts to figure out the relationship of each to the other, doing controlled experiments, utilizing the basic principles of experimental design and data analysis, questioning and wondering about natural events, performing mathematical calculations, and working with geometric shapes.

Dance and Singing Activities - The girls showcased their dancing styles as part of the closing reception. In addition to dance other kinesthetic activities include:



**For those girls that are musical/rhythmic intelligence thinkers**

**Interpersonal Intelligence strategies**

**As the girls move into the high school environment we want them to learn to utilize their own intra-personal intelligence**

sports (swimming), hands on experimentation and the use of body language (modeling).

Music-related Activities -The girls immediately responded to music either appreciating or criticizing what they heard. As part of the closing program musical selection were rendered.

**Communication Activities - The girls envision concepts** from others point of view in order to better understand how they think and feel. They need to develop the ability to sense feelings, intentions and motivations. Exercises included: seeing things from other perspectives (dual-perspective), listening, using empathy, understanding other people's moods and feelings, counseling, co-operating with groups, noticing people's moods, motivations and intentions, communicating both verbally and non-verbally, building trust, peaceful conflict resolution and how to establishing positive relations with others.

Personal Assessment Activities -It is important for students to evaluate and understand their inner feelings, dreams, relationships with others, strengths and weaknesses. The program encouraged the girls to recognizing their individual strengths and weaknesses, reflecting and analyzing themselves, awareness of their inner feelings, desires and dreams, assess their thinking patterns, reasoning with themselves and understanding their role in relationship to others

**Activities:**

**Measurable Objectives**

The girls took the Science Process Assessment for Middle School (SPAMS) and the Maryland High School Assessment 2002 (MHSA) for ninth grade students. The MHSA is a four-part assessment in: Mathematics, Government, Biology and English. The Pre- and Post test scores will be compared in order to develop a comprehensive portfolio of the girl's achievements.

The students (girls) developed a web page chronicling their program experiences and presented their research in a PowerPoint presentation. The participants also, presented their research on a science fair topic of their choice using Microsoft Power Point software at the closing reception. The science fair topics were in the following areas: physical science, biological science, mathematics-computer science, engineering and earth-environmental science.

**Achieved Objective**

The girls mathematics and science skills were strengthened using constructivist classroom methods and instructional strategies, this was facilitated through: a group learning approach, open discussion by posing questions related to a topic in context, hands on activities, writing exercises, critical thinking activities for mathematics, algebra theory and problem solving.

Students created a website displaying: their career goals, an abstract or hypothesis of their research and what they have learned in the WISE program. The girls were taught basic HTML and Beginning PowerPoint as part of their technology development. The students also had individual e-mail accounts to continue their cyber communication with fellow WISE staff and participants, mentors, tutors and University faculty.

**Results:**

*Expected Objective #1:* To increase the participants’ skills in Science, Mathematics and Biology.

*Measurable Objective #1:* The 15 girl participants took the Science Process Assessment for Middle School (SPAMS) and the mathematics and biology sections of the Maryland High School Assessment (MHSA). The SPAMS assessment contained the science content areas the girls should have had previous to the completion of middle school (8<sup>th</sup> grade). The total possible scores in each test area were: science 50, mathematics 38 and biology 53. The pre and post test scores were compared in order to develop a comprehensive portfolio of the girl’s learning.

*Achieved Objective #1:* The girls science, mathematics and biology skills were strengthened using constructivist classroom methods and instructional strategies, this was facilitated through a group learning approach, open discussion by posing questions related to a topic in context, hands on activities, writing exercises, critical thinking activities for mathematics, algebra theory and problem solving. Increases in all areas tested were exhibited. The paired sample T Test, was used to compare the mean of the two variables. This test computes the difference between the two variables for each case, and tests to see if the average difference is significantly different from zero. The assumption was that both variables were normally distributed. The null hypothesis was that there was no a significant difference between the mean of the pre- and post test. The descriptive statistics for both variables are presented. The test shows that the mean for all of the post-test scores were higher than the pre-test scores.

Table 4 shows the Paired Sample T Test which is based on the difference between the pre- and post test variables. Note under paired differences the descriptive statistics for the difference between the variables as follows. The T values are: -4.435, -8.746 and -6.890 with 14 degrees of freedom (df). Our significance for this test the Sig. (2-tailed) Paired Differences which are: .001, .000 and .000. All of the Paired Difference values are less than .05, meaning there is a significant difference between the pre and post test scores.

**Table 4: Paired Samples Test**

Pair	Mean Paired Differences	Std. Deviation Paired Differences	Std. Error Mean Paired Differences	Lower 95% Confidence Interval of the Difference Paired Differences	Upper 95% Confidence Interval of the Difference Paired Differences	t	df Paired Differences	Sig. (2-tailed) Paired Differences
Pair 1 Pre Science – Post Science	<b>-2.86667</b>	<b>2.50333</b>	<b>.64636</b>	<b>-4.25297</b>	<b>-1.48037</b>	<b>-4.435</b>	<b>14</b>	<b>.001</b>
Pair 2 Pre Mathematics – Post Mathematics	<b>-6.60000</b>	<b>2.92282</b>	<b>.75467</b>	<b>-8.51860</b>	<b>-4.98140</b>	<b>-8.746</b>	<b>14</b>	<b>.000</b>
Pair 3 Pre Biology – Post Biology	<b>-4.60000</b>	<b>2.58567</b>	<b>.66762</b>	<b>-6.03190</b>	<b>-3.16810</b>	<b>-6.890</b>	<b>14</b>	<b>.000</b>

*Expected Objective #2:* To increase the participants' skills in the use of technology and comfort level through the use of practical application.

*Measurable Objectives #2:* The students developed a web page chronicling their program experiences and presented their research in the form of a power point presentation.

*Achieved Objective #2:* The students were taught HTML and power point as part of their technology development. Participants created web content that they added to a website created for the program. On the site you would find their career goals, an abstract or hypothesis of their research and what they had learned in the WISE program. The students also had individual e-mail accounts to continue their cyber communication with fellow WISE staff and participants, mentors, tutors and faculty.

*Expected Objective #3:* To increase the participants' familiarity with the scientific process and funding agencies mission and goals through the selection of a Science Fair topic and development of project methodology for presentation.

*Measurable Objectives #3:* The students were taught the scientific method and how to develop a research project.

*Achieved Objective #3:* The students presented their research on a science fair topic of their choice using power point software at the closing reception. The science fair topics were in the following areas: physical science, biological science, mathematics-computer science, engineering and earth-environmental science. In addition, the students presenting their research, a one page snap-shut of the content of their web page was included as part of their summer experience.

## **Conclusion:**

The WISE program proved to be a successful approach towards inspiring minority women to pursue career paths in science, mathematics, computer science, engineering and education. The students were able to increase their skills in Science, Mathematics and Biology as well as their skills in the use of technology. In addition, through their research, they were made familiar with the scientific research process. The Science Process Assessment for Middle School (SPAMS) and the mathematics and biology sections of the Maryland High School Assessment (MHSA) served as program performance indicators. The results of these assessments indicated that this program can serve as a model for STEM development programs for girls. Tracking of the girls indicated that one-hundred percent (100%) graduated from high school or completed their GED. Seventy percent (70%) of the girls enrolled in a community college or four year higher education institution. The evidence of this project suggests that minority girls can make great strides in the pre-preparation for college through mentoring and through special academic enrichment activities specifically designed to address their individual needs. The program is clearly replicable with limited funding. Key to the success of this program was: 1) the proper assessments of individual educational needs; 2) quality mentors who took a personal interest in the girls; 3) tracking of girls through high school to college; and 4) quality instructional strategies that facilitated increasing their skills in STEM. The Director of the program was instrumental in following-up with the girls after the program concluded. This was important in motivating the girls to pursue college and STEM careers. The WISE program gave minority girls with diverse backgrounds an opportunity to be exposed to a college campus and experience

excellence in education in STEM careers, and have an opportunity to connect with female mentors, scientists, and professionals.

## **Bibliography**

[1] Maryland State Department of Education (June 2001), Keys to Math Success A Report from the Maryland Mathematics Commission.

[http://www.msde.state.md.us/Special\\_ReportsandData/keys.pdf](http://www.msde.state.md.us/Special_ReportsandData/keys.pdf)

[2] College Entrance Examination Board (2011), 2011 College-Bound Seniors: Maryland

[http://professionals.collegeboard.com/profdownload/MD\\_11\\_03\\_03\\_01.pdf](http://professionals.collegeboard.com/profdownload/MD_11_03_03_01.pdf)

[3] School Improvement in Maryland (2011), MSA Mathematics

<http://mdk12.org/data/MSA/GradeLevel.aspx?Nav=1.2:5.1:10.99:15.99:2.22:20.2:3.4>

[4] School Improvement in Maryland (2010), HSA Test Performance Status

<http://mdk12.org/data/HSA/TestPerformanceStatus.aspx?Nav=1.5:5.1:10.99:15.10#bargraph-allgrades>

[5] 2011 Maryland Report Card (2003 to 2011), MSA Results for Mathematics for Grade 8, Female Students

<http://msp.msde.state.md.us/MsaTrends.aspx?PV=1:8:30:AAAA:2:N:0:13:2:2:0:1:1:1:2>

[6] Maryland Report Card (2011), 2003 to 2011 MSA Results for Science for Grade 8, Female Students

<http://msp.msde.state.md.us/MsaTrends.aspx?PV=1:8:30:AAAA:2:N:0:13:3:2:1:1:1:1:2>

**Teaching Multidisciplinary Robotics and Mechatronics Integrated with  
Bionics and Solar Energy**

Richard Y. Chiou  
Engineering Technology  
School of Technology and Professional Studies  
Goodwin College  
Drexel University  
Philadelphia, PA 19104

Michael G. Mauk  
Engineering Technology  
School of Technology and Professional Studies  
Goodwin College  
Drexel University  
Philadelphia, PA 19104

M. Eric Carr  
Engineering Technology  
School of Technology and Professional Studies  
Goodwin College  
Drexel University  
Philadelphia, PA 19104

Bret Davis  
Engineering Technology  
School of Technology and Professional Studies  
Goodwin College  
Drexel University  
Philadelphia, PA 19104

# **Teaching Multidisciplinary Robotics and Mechatronics Integrated with Bionics and Solar Energy**

Richard Y. Chiou, Michael G. Mauk, M. Eric Carr, and Bret Davis  
Engineering Technology  
School of Technology and Professional Studies  
Goodwin College  
Drexel University  
Philadelphia, PA 19104

## **Abstract**

Engineering Technology (ET) is an undergraduate degree program at Drexel University (DU). Several innovative laboratory components are integrated in MET 205 Robotics and Mechatronics (a 10-week upper-level undergraduate course) to achieve maximum effectiveness in teaching multi-disciplinary concepts in emerging fields. The primary educational objective of the course is to introduce students to the multidisciplinary theory and practice of robotics science and technology, integrating the fields of computer science, electrical engineering and mechanical engineering. This paper discusses laboratory development and the hands-on learning experience within the context of this capstone course on robotics and mechatronics. Topics covered include the innovation of teaching industrial robotics to undergraduate students working on solving real-world problems, particularly as it applies to multidisciplinary fields such as bionics and solar energy.

## **Introduction**

This paper presents the establishment of a robotics and mechatronics laboratory for teaching and research integrated with the emerging fields of bionics and solar energy through an NSF project involving undergraduate and graduate students, and faculty at Goodwin College of Drexel University. Mechatronics-based robotics is a well-recognized motivational vehicle for applied engineering education<sup>1-5</sup>. Not only is it an enjoyable topic for many students, it has a broad appeal due to its wide scope, including aspects of electrical, mechanical, computer engineering, and information technology. Further, the design of such systems is an excellent tool for reinforcing applied engineering concepts. It is important for instructors in robotics to understand, however, that robotics is not just a tool to teach other aspects of engineering. Rather, it is a robust and mature discipline in its own right, with important applications in a wide range of fields.

This laboratory development component in this NSF-sponsored project integrates various tools such as robots, pneumatic actuators, sensors, web-cameras, conveyors, and programmable logic controllers (PLCs) Internet communications links are used to connect to cross-platform systems. Visual Basic Net is used to create graphic user interfaces (GUIs) for performing online analysis and to allow remote interaction with the system. These tools can be used by students to develop their own ideas in the fields of bionics and solar energy, obtain industrial experience in participating in cutting-edge research and development efforts, and develop familiarity with various sensors while learning different ways to make them work together with various robotics and mechatronics. Here we describe a set of experiments and classroom discussions that allow students to compare traditional (microprocessor-driven) robotics engineering with simulation using PLCStudio<sup>6-8</sup>.

We have constructed a series of fully functional robotics experiments, and have been able to incorporate experiments involving many aspects of mechatronics in various classes throughout the Engineering Technology curriculum. These experiments can be integrated into course segments involving robotic systems, solar energy, bionics, and emerging science and technologies such as microrobotics and microfluidics. Integrating these topics into courses across the Engineering Technology curriculum provides fresh, exciting topics of study and research for Engineering Technology students<sup>9-16</sup>. Furthermore, the establishment of the state-of-the-art laboratories allows Drexel to develop learning schemes for engineers in the Greater Philadelphia Region's key industries. Four laboratory development efforts are described in this paper.

## **1. Web-enabled Robotic Lab**

Our Laboratory facility (constructed with the support of Yamaha Robotics) is shown in Figure 1. The equipment includes the following: Yamaha YK250X, Yamaha YK150X, Yamaha YPX250, Yamaha YP330A, Yamaha RCX40 /w opt. on-board Ethernet card, Yamaha RCX40 /w opt. on-board Ethernet card, Yamaha PRCX-T, Yamaha QRCH, Yamaha DRC-R, DLink DCS-5300, machine vision DVT, Conveyor Dornier 6100 Series, HP m1050e, and Allen Bradley 1756 Series PLC. The PLC is capable of connecting to the Ethernet and can also be controlled using a PC/Server. An Ethernet camera is used for constantly viewing the robot movement. The machine vision sensor and conveyor belt are also integrated in the system.

All the devices, such as the robots, web-camera, sensors, programming logic control (PLC), are connected to the Ethernet LAN. This reduces the wiring infrastructure needed to link every device and enables users (students) to operate/control all the equipment, either locally or via the Internet.

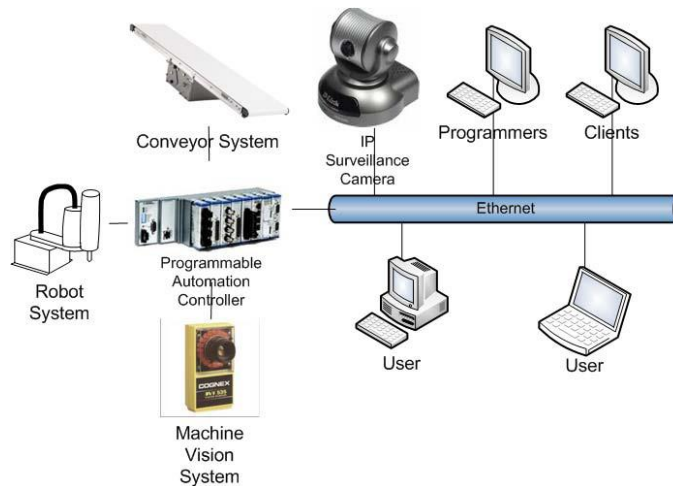


Figure 1: Internet-based robotics and mechatronics laboratory

The communications protocol utilizes TCP/IP (*Transmission Control Protocol/Internet Protocol*) which is a standard Internet Protocol so PCs with Internet Access can exchange data with the robot controller. This unit uses 10BASE-T specifications, so UTP cables (unshielded twisted-pair) or STP cables (shielded twisted-pair) can be used. This makes cables and wiring installation relatively user-friendly. Commands are sent to the controller using Telnet, a protocol which allows a computer to act as a remote terminal on other machine, anywhere on the Internet. The controller transparently accepts input directly from the user's computer (via a telnet client); output for the session is directed to the user's screen.

### A Case Study in a Robotic Control Experiment through Internet

Directly under the online robotic control system interface is the IP surveillance camera view (shown side-by-side with the control module in Figure 2.) The user is able to view the live streaming image from the IP surveillance camera with this module. Users can view the camera by pressing on the green play button located under the surveillance screen. When this screen is accessed, users are able to perform tasks such as zooming in and out on the web-camera screen. The video itself streams in real time. At the bottom of the screen is a [Stop Program] button, which allows the user to terminate the program at any time during testing.

To the right of the IP surveillance camera display is a DataLink module (labeled [DATA]) that allows users to view the radius of the test pieces. The radius of the object on the conveyor belt is determined, in order to check if it conforms to the required statistical process control limits.



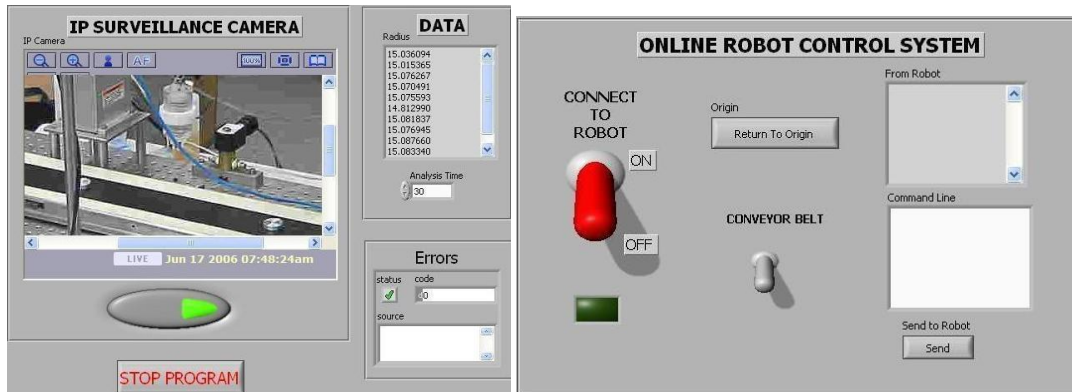


Figure 2: Online robot control system module, surveillance camera module, and DataLink module

We further explore how robotic simulation can be adapted to the classroom in conjunction with a physical setup to enhance the students' learning experience. PLCStudio was created with the intention of being used in industry for the purpose of designing and simulating a complete robotics and PLC system before physically implementing it on the factory floor. Other software packages used by manufacturers are designed solely to model the physical layout and kinematics of the robots. With the integration of sensors, robots, conveyor belts, and other devices, it is not sufficient to simulate only the robots' movements.

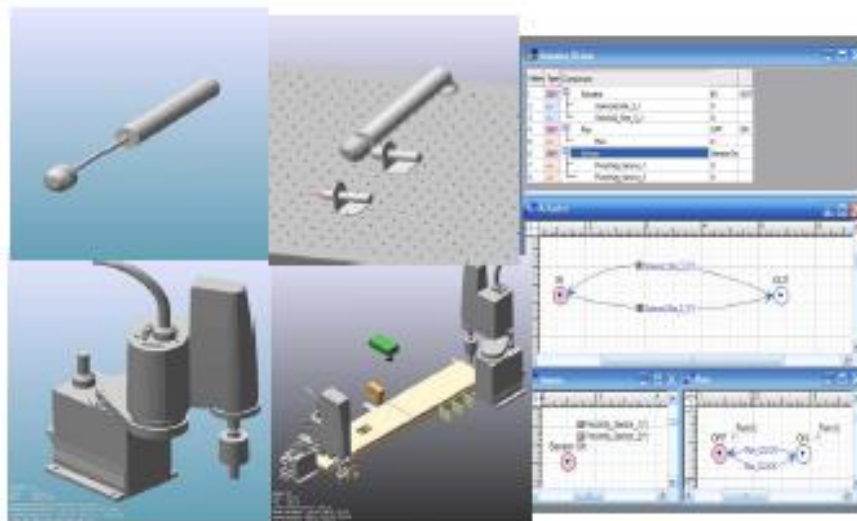


Figure 3: Component Model, logical I/O model, and cell 3D model for simulation

All of these components must be able to communicate with each other through varied inputs and outputs. This is commonly performed today through a PLC, which uses programming to emulate mechanical switches and relays. Systems consisting of inputs and outputs do not require structured testing to be constructed, but for more complex systems, testing the designed PLC code becomes vital. PLCStudio works in conjunction with STEP 7 to allow the user to not only fabricate a virtual 3D representation of the factory floor, but also write and test the PLC ladder logic in a virtual environment before it is run on a physical PLC. PLCStudio's design process can be broken down into three main steps: the component model, logical I/O model, and cell model. These three steps are performed in hierarchical phases to produce the final virtual model as shown in Figure 3.

### Advanced application –robotic control

This experiment performs quality control testing on machined parts and sorts them based on preset tolerances. The devices used in the physical part of the experiment are an YK220X SCARA robot, YK250X SCARA robot, machine vision camera, conveyor belt, and a photoelectric sensor. The layout of the components in the workcell can be observed in Figure 4.

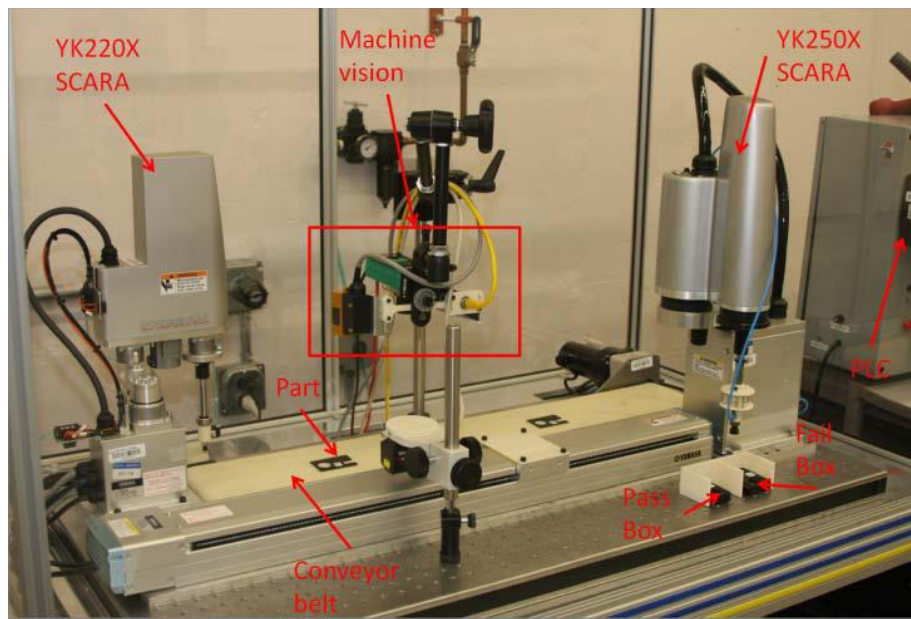


Figure 4: Robotic workcell equivalent to PLCStudio virtual system

Students are given the cell model and I/O model for the simulation. To run this simulation, the students must create a ladder logic program that uses the input data from sensors and sends appropriate commands to the robots. Figure 5 shows the ladder logic utilized by PLCStudio on the left and the logic used by RSLogix on the right. It is necessary to use RSLogix because PLCStudio is only compatible with STEP 7 which works with Siemens PLCs, whereas the PLC used in the lab is made by Allen Bradley which utilizes RSLogix.



Figure 5: Students building a robotic cell and programming automation by PLCStudio

PLC programs can be tested in PLCStudio and implemented in the robotics and mechatronics laboratory. The robot sequence timing is measured in the laboratory experiment. The students collect data to measure the cycle time of the robotic cell. If the robot receives a pass signal, then it runs the “pass” routine which sorts the part into the pass bin. If it receives a fail signal input then it runs its “fail” routine which sorts the part into the fail bin.

### **3. Bionic Robotics**

Bionic Robotics allows students to develop their knowledge of engineering and become familiar with a variety of advanced components that are used. This knowledge can benefit students in fields such as Mechanical, Electrical, Industrial, and Bio-Engineering. Providing students with a hands-on approach when teaching robotics classes enables students to become aware of how mechatronic design, rapid prototyping, and computer control can drastically influence the downstream design and manufacturing processes. This is especially helpful for students in the mechanical, electrical, and industrial concentrations, since they have a high probability of designing parts that will require machining processes during their manufacture. A research case study on bionic robotics is presented here. It demonstrates the practical usefulness of biologically inspired computing for the mobile robotic domain and realization of multiple disciplinary features.

#### **Robotic Control System Design**

A biologically-inspired walking robot has been designed, and is used as an educational example in MET 205 Robotics and Mechatronics. The walking robot contains components such as rapid prototyped legs, servomotors, and a Bluetooth wireless communication module. It contains a programmable PIC16F887-I/P microcontroller which is programmed using PIC Assembly language. The onboard servo (slave) microcontroller located on the circuit board directly controls the eight servomotors on the robot. It interprets high-level commands and produces the proper sequence of timed pulses necessary to move the eight servos in the desired sequences. The microcontroller on the breadboard produces a sequence of timed 7-bit

command words (such as walk-forward, stop, stand up, walk backwards, sit, etc). The microcontroller on the circuit board receives these commands and implements them as canned timing signal sequences to be sent to the eight servomotors – one shoulder servo and one knee servo per leg. The shoulder servos sit inside and are attached directly to the underside of the chassis. The knee servos fit inside each leg of the robot. The prototype robot can be seen in Figure 6.

The addition of a RN-41 Bluetooth module allows the students to control the robot from certain Bluetooth capable devices, such as smartphones or laptops. This gives them hands-on experience with wireless control of embedded systems. A control program has also been implemented on an Android smartphone using Mintoris Basic for Android. The program allows for remote control of the robot via Bluetooth, by utilizing the smartphone's internal accelerometer. By tilting the phone along different axes, the canned movement routines programmed into the robot's onboard microcontroller can be executed. This type of application provides students an interesting and functional example of how different systems can be integrated together for control of robotic applications.

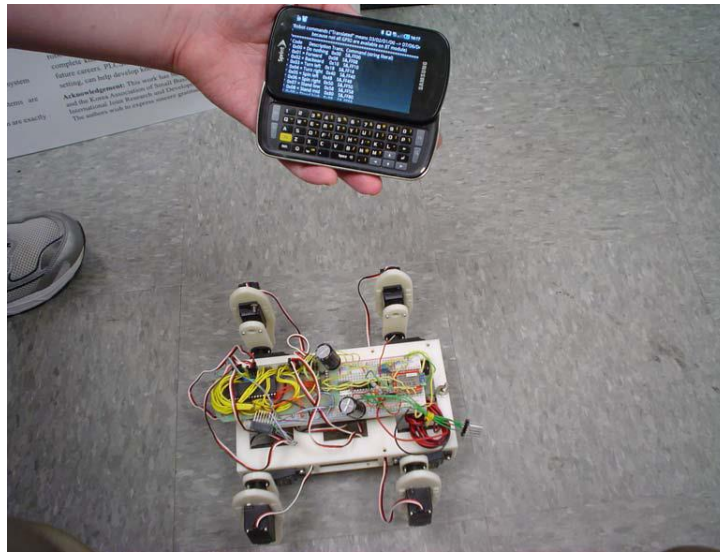


Figure 6: The walking robot in action

As currently implemented, the robot is a two-degree-of-freedom quadruped (using eight servos) with the circuit itself upgradeable to hexapod configuration with three degrees of freedom (which would use a total of eighteen servos) if the MCU speed is increased to 20MHz or more. Our robotic laboratory experiment emphasizes those aspects of microcontroller-based control systems and robotics that are most closely related to computer science. These aspects include the following:

- Architectures and instruction sets of microcontrollers
- Interfacing a microcontroller with memory and I/O
- I/O techniques (serial, parallel, etc)
- Microcontroller programming languages and techniques
- The use of timing in development of the gait system

- Walking efficiency of the robot

The current walking gait is hand coded and is diagrammed in Microsoft Excel as an X-Y plot. An initial estimate at a footfall sequence and foot path was made by slow-motion video observation of a walking draft horse. Specifically, the gait sequence used is: LR □ LF □ RR □ RF etc, with a 90 degree phase angle between each. Unlike a horse, however, the SIGMA robot uses reverse symmetry: the front legs of the robot “pull” while the rear legs “push.” (This allows closer spacing of the onboard servos, allowing a smaller physical size for the chassis.) The footfall sequence and the foot paths are reversed for the backwards gait. (Essentially, the backwards gait is the same as the forwards gait reversed in time.) The “spinning-in-place” and turning gaits are loosely based on the walking gait. The gait sequence timing and walking efficiency are measured in the laboratory experiment as shown in Figure 7. The students in MET 205 Robotics and Mechatronics, working in groups, collect data for gait cycles of the walking robot.



Figure 7: Students measuring walking gait and efficiency of the bionic robot in MET 205 Robotics and Mechatronics.

#### **4. Automated Solar Cell Surface Roughness Measurement System**

Renewable Energy includes solar energy, hydro power, wind energy, biomass, etc. Solar energy is one of the most popular and widely used types of renewable energy. The applications of solar energy science and technology range from grid electricity generation to running small embedded appliances. The abundance of sunlight delivers tremendous amounts of power to the surface of the earth. Solar cell conversion efficiency is determined by the various factors involved with the collection and conversion from light energy to electrical energy. Thus, the quality of solar cells is a crucial factor in determining their efficiency. Hands-on renewable energy related classes, labs, and projects promote alternative energy efficiency education.

Figure 8 shows the architecture of the remote surface roughness measurement system. The PC-based remote inspection system is composed of a YK250X 4-axis SCARA robot, RCX 140 controller, a F1010-700 1-axis robot, SR1-X robot, a laser check sensor, an IP Surveillance camera, and an Allen Bradley PLC controller. The laser check sensor has a

built-in processor which allows it to perform real-time algorithms, along with live monitoring capabilities. The process is designed to be Ethernet-based using TCP-IP communications. After a successful TCP handshake, images and extracted measurements can be sent back and forth remotely between the servers and clients. The laser check sensor is programmed with necessary algorithms to calculate the various surface roughness parameters. In the LabVIEW-based graphic user interface (GUI), statistical quality algorithms for remote measurement are calculated. The controller communicates with the robot to instruct it to perform the required operations.

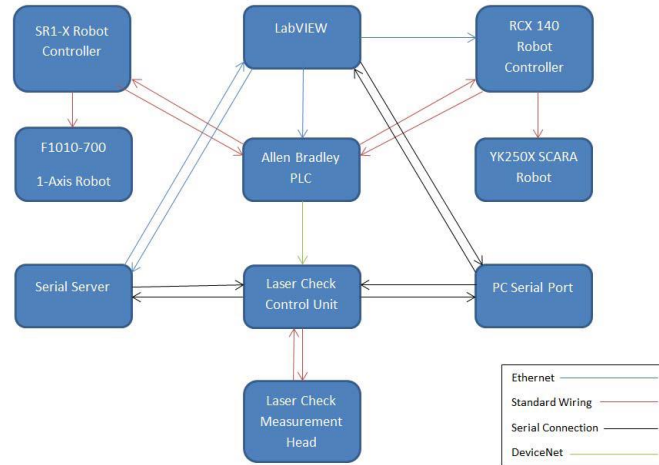


Figure 8: Automated surface roughness system diagram

### Robotic Workcell

Utilizing robots in the process of performing surface roughness scanning allows for both full automation as well as precise and repeatable measurements. The two robots used in this cell are the Yamaha YK250X SCARA 4-axis robot and the Yamaha F1010-700 1-axis robot. The measurement head of the Laser Check system is mounted to the tool arm of the SCARA robot. The piece to be scanned is mounted to the 1-axis robot. The scan is performed by incrementing the 1-axis robot in what shall be designated as the y-axis  $i$  number of times. Once completed, the 1-axis robot moves back to its initial position and the SCARA robot increments in what shall be designated as the x-axis, and the 1-axis robot begins its incrementing cycle again. This process repeats  $j+1$  times,  $j$  being the number of increments the SCARA robot makes. This produces a 2D array or matrix of data:  $M_{i+1,j+1}$ , which can later be used to plot a 3D graph. The robotics workcell can be seen in Figure 9.



Figure 9: Robotic workcell for solar cell surface roughness measurement

### **LabVIEW Program**

To initiate a connection, a configuration block specific to the type of connection is used. Once the connection is established, TCP/IP or Serial Read/Write blocks are used to issue a call for data to the Laser Check system and read the data that comes in. To control the flow of incoming data, so that data is not erroneously read twice or skipped over, a case structure is employed, which is triggered by the falling edge of the laser trigger in the PLC. This essentially allows the program to read the data only right after the laser turns off. The data that flows in comes in the form of an ASCII string. To convert this into a floating point value, the string is parsed and header and footer values are removed. The remaining value is then converted to a float value using a type cast function. This data is then sent along and placed into a 2D array that is a set of 1D arrays that represent each scan along the face of the material. This array is then sent to the 3D graph and table on the front panel, as well as to an external spreadsheet file. The connections between the program and the robots are made through both the PLC and through Telnet communication using TCP/IP. The 1-axis robot's controller does not support an Ethernet connection, and as such, the program is initiated by connecting to the PLC via Ethernet and flipping a control bit, which initiates the 1D scan. The SCARA robot's controller does support Ethernet, and is connected to directly using TCP/IP.

### **Surface Roughness Measurement of Solar Cells**

The one-axis robot positions the solar cell precisely under the sensor. The controller can be externally triggered by one of the robots or a controlling software package. The surface of the cell is scanned by stepping the one-axis robot in 1 mm increments; the surface roughness data is then captured by the controller. This setup can be incorporated with the blob analysis vision system to encompass a fully-developed quality control procedure to evaluate the efficiency of solar cells. Figure 10 shows how multiple SCARA robots can help in constructing surface profiling through the use of LabVIEW program.

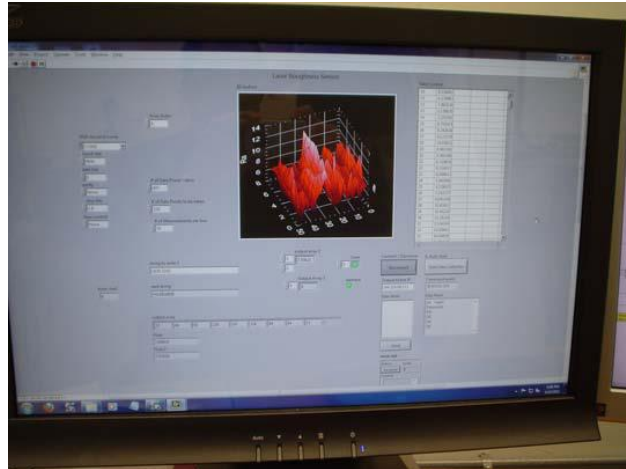


Figure 10: LabVIEW serial and Ethernet front panels interface for surface profiling

There are minor differences between both front panels, which can be seen on the left side of each. These differences are due to variations in connecting and reading from the serial connection either locally or via Ethernet. The two buttons on the right are responsible for connecting to the robots and subsequently running their programs. The graph in the middle of the screen plots a visualization of the incoming height/roughness data, and the table next to it displays the raw numerical data as it comes in.

## Conclusions

This paper describes laboratory innovations for the enhancement of undergraduate level teaching of a capstone course (MET 205 Robotics and Mechatronics) integrated with emerging technology. The trends in emerging fields of bionics and renewable energy have changed the teaching schemes for industrial robots. The new developments allow the students to program, monitor, and control robotic operations through the Internet using the Windows-based graphical user. Also presented is a non-contact-based approach to evaluate certain performance methods and characteristics of solar cells by using image processing. This allows remote control and monitoring of robotic operations, including bionic robotics and renewable-energy systems control via TCP/IP and Bluetooth.

## Acknowledgement

The authors would like to thank the National Science Foundation (Grant No. NSF-DUECCLI-0618665) for its financial support of the project.

## Bibliography

1. V.B. Sunil & S.S. Pande 2003, "WebRobot: Internet based robotic assembly planning system," *Computers in Industry* 54 (2004) 191–207.
2. Melinda F. Robinette, Associate Member, IEEE & Rachid Mansour, Member IEEE, "ROBOT-DRAW, an Internet-Based Visualization Tool for Robotics Education," *IEEE Transactions on Education*, Vol. 44. No. 1, Feb 2001.
3. Angeles, Jorge, "Fundamentals of Robotic Mechanical Systems: Theory, Methods and Algorithms," Springer-Verlag, New York, Incorporated Date: 2002.
4. SME – Machine tools begin connecting to the Internet Manufacturing, 9/2001.
5. Higley, J., McLees, C., and Zahraee, M., "A Case Study in Laboratory-Based Online Courses – Teaching CNC Programming," *Proceedings of IMECE '03 2003 ASME International Mechanical Engineering*



- Congress, Washington, D.C., November 15–21, 2003.
6. Hu, H., Yu, L., Tsui, P. W. and Zhou, Q, "Internet Based Robotic System for Teleoperation, Assembly, and Automation," *International Journal of Assembly Automation*, Vol.21, No.2, pp.143-151, 2001.
  7. Potgieter, J and Bright, G., "Modular Mechatronics Control System for Internet Manufacturing," *Proceedings of the 18<sup>th</sup> International Conference on CAD/CAM, Robotics and Factories of the Future*, Porto, Portugal, pp. 529-536, July 2002.
  8. Taylor, K. and Dalton, B., "Internet Robotics: A New Robotics Niche," *IEEE Robotics and Automation*, Vol.7, No.1, pp.27-34, March 2000.
  9. Pew Charitable Trusts, "Who's Winning the Clean Energy Race?" March 2010, [www.pewtrusts.org/uploadedFiles/wwwpewtrustsorg/Reports/Global\\_warming/G-20%20Report.pdf](http://www.pewtrusts.org/uploadedFiles/wwwpewtrustsorg/Reports/Global_warming/G-20%20Report.pdf).
  10. Sage, Daniel; Unser, Michael. "Teaching Image-Processing Programming in Java." *IEEE SIGNAL PROCESSING MAGAZINE*, Nov. 2003. <<http://bigwww.epfl.ch/publications/sage0303.pdf>>.
  11. Bloechle, Walter. "Measuring Surface Roughness with an Optical Sensor." *Hohner Corp*, 8 July 2009 <[http://archives.sensorsmag.com/articles/0499/0499\\_58/](http://archives.sensorsmag.com/articles/0499/0499_58/)>.
  12. Ordaz, Miguel; Lush, Gregory. "Machine Vision for Solar Cell Characterization." *International Society for Optical Engineering*, 1 Dec. 2009.
  13. Laliberté T., Gosselin C. and Côté G., 2000, "Rapid Prototyping of Lower-Pair, Geared-Pair and Cam Mechanisms," Proceedings of the ASME Mechanisms and Robotics Conference, Baltimore MD, September 10-13, 2000, Paper DETC2000/MECH-14202.
  14. Won J., DeLaurentis K. and Mavroidis C., "Rapid Prototyping of Robotic Systems," Proceedings of the 2000 IEEE International Conference on Robotics and Automation,
  15. "Bailey, S. A., Cham J., G., Cutkosky, M. R., Full, R. J., "Biomimetic Robotic Mechanisms via Shape Deposition Manufacturing," *Robotics Research: the Ninth International Symposium*, John Hollerbach and Dan Koditschek (Eds), Springer-Verlag, London, 2000.
  16. Bhömer, M. t., Bartneck, C., Hu, J., Ahn, R., Tuyls, K., Delbressine, F., et al., "Developing Novel Extensions to Support," Prototyping for Interactive Social Robots, Proceedings of the 21st Benelux Conference on Artificial Intelligence (BNAIC 2009), Eindhoven, pp. 11-17, 2009.

**Engineering For All**  
**The Temple University Department of Mechanical Engineering General Education**  
**Courses**

PAUL FAGETTE

Department of Mechanical Engineering,  
Temple University, Philadelphia

SHIH-JIUN CHEN

Department of Mechanical Engineering,  
Temple University, Philadelphia

GEORGE R. BARAN

Department of Mechanical Engineering,  
Temple University, Philadelphia

SOLOMON P. SAMUEL

Department of Orthopedic Surgery,  
Albert Einstein Medical Center, Philadelphia, PA

MOHAMMAD F. KIANI

Department of Mechanical Engineering,  
Temple University, Philadelphia

**ENGINEERING FOR ALL**

## **The Temple University Department of Mechanical Engineering General Education Courses**

### **Abstract**

The Mechanical Engineering Department at Temple University has crafted two courses for the General Education Program that expand the alternatives for students to fulfill their general science credits. The courses are designed for non-engineering, lower division students complete with lectures, labs, demonstrations, exams, extensive reading of both text and peer-reviewed articles, research projects, and presentations. The classes address multiple general education requirements while offering enlightenment and understanding of engineering systems, engineering principles, and design.

### **Introduction**

Engineering curricula centers upon the training and development of engineers and follows a cloistered academic approach. Rarely can anyone outside the discipline take engineering courses. ABET further reinforces this approach in order to maintain rigor and consistency in the delivery of course work. Coupled with traditional academic boundaries, a general lack of understanding exists by the general public about engineering systems, basic scientific/engineering principles, and engineering design. In 2005, the Department of Mechanical Engineering at Temple University responded to a request from the General Education Program to create new courses for non-engineering students across the university.

Accordingly, the Department crafted two new courses: Technological Transformations and the Bionic Human, both of which were targeted to lower division, non-engineering students. These new courses helped to enlarge and expand the nature of general education courses but also brought an understanding of engineering principles, systems, and approaches to a larger segment of the university population. The new curricula followed the guidelines set forth in the General Education request for science/engineering courses which included problem sets, laboratory experiences, research based upon appropriate professional literature, and communication skill development (both written and oral).

Teams within the Department configured unique courses to fit the guidelines. Both courses have evolved through time with feedback from both instructors and students. Accordingly, more discrete skills sets were refined and delivered. The net result is a tandem of courses that engage and expand student awareness about the engineering aspects of their world.

### **Call to Arms**

In 2005, the General Education Program at Temple University challenged the many colleges on campus to create a new series of general education courses to expand the offerings for

students and enhance their understanding of the world. This effort included a wider range of classes that would count for general science credit.

In the promulgation it was stated “faculty in all schools and colleges are encouraged to think across disciplinary lines about the best ways to convey the kinds of sophisticated knowledge that will produce Temple graduates able to see connections in seemingly disparate information.” This new program summed these efforts with the motto “Dare to know!”

In a descending order, a series of general to specific skills and requirements were outlined. Accordingly, each course had to accomplish the following required goals associated with the general education program:

1. Develop students’ thinking and communication skills
2. Expand students’ knowledge in the subject area
3. Develop students’ ability to make informed judgments in the subject area;
4. Promote intellectual curiosity and life-long learning
5. Develop skills in identifying, accessing and evaluating sources of information

An additional set of desirable goals were to be addressed as applicable:

1. Develop ethics, citizenship, and awareness of current issues
2. Promote collaborative learning and teamwork skills
3. Develop an understanding of and appreciation for Temple’s urban setting and its regional and global connections
4. Develop students’ ability to analyze and interpret data
5. Develop students’ ability to identify and solve problems

The announcement moved from general requirements to more specific definitions. Eight general education areas that crossed most disciplines were defined including natural sciences or technology. The overall purpose was to promote understanding of scientific thinking and associate methods as well as an understanding of how technology affects human life. Classes offered under this heading would partially fulfill the general education science requirement.

The General Education request detailed further criteria made several telling points that affected how engineers could design these classes. These are General Education courses with students from across the student population, virtually all of whom have no basic or conceptual understanding of engineering or engineering concepts. This diversity of skills and backgrounds constitute the major challenge for designing an engineering course applicable to the general student population. Pertinent to the Dept. of Mechanical Engineering, the list of possible classes might include bioengineering and development of technology.

The requirements further requested that students learn how to access scientific or engineering literature along with an emphasis on the nature of engineering or scientific

inquiry and research methodology. The basic rationale was that students should be able to understand basic science and engineering technology reports associated with the news, health, environmental, etc. The proposed courses should attempt to achieve student success in as many of the following skills as possible:

1. Know the difference between a law, theory, and hypothesis
2. State examples of laws, theories, hypotheses for content area
3. Be able to conduct an experiment with test, observations, and conclusions
4. Be able to identify relevant facts from irrelevant facts
5. Understand the sequential nature of science (how facts build on one another)
6. Use facts to explain natural phenomena
7. Use content to interpret current news issues related to science and technology
8. Understand the difference between science and pseudoscience
9. Show the importance of quantifying to understand natural phenomena
10. Develop an inquiry-based line of reasoning and use of skeptical thinking
11. Understand how applications of technology evolve
12. Understand the relationships of basic science to technology applications

Clearly not all of these apply to engineering but #2, 3, 5, 9, 11 and 12 do.

In addressing all these guidelines it would appear that the class was basically outlined but the implementations offered considerable latitude. The remaining key was how to assess if students have actually achieved understanding and to what degree. Here the engineers have a distinct advantage. ABET has encouraged a systematic pedagogy about how to address main concepts and assess understanding through a variety of means. General education engineering-based courses could include traditional lecture, research and presentation efforts, guest speakers, demonstrations, even field trips.

Working within these guidelines, the Department of Mechanical Engineering appointed two teams to develop courses that would enlighten students on different aspects of engineering that would meet general science requirements.<sup>1</sup>

## The Response

Offering such courses addresses a major need recognized by the General Education Program. Students in the general university population rarely know or understand anything about engineering, engineering principles, or engineering systems unless they have personal contact with an engineer. They exist in a world largely defined and developed by engineering but usually have no clue to its existence. Thus, these courses offer engineering an opportunity to expand awareness of the discipline and its impact on society. The Department of Mechanical Engineering formulated a dual response. One was the Bionic Human, a bioengineering-based course. The other, Technological Transformations, followed the development of older engineering traditions which included mechanical, civil, electrical, and some chemical engineering.

## Technological Transformations

Jim Chen headed the effort to create a general engineering course. In the quest for examples and materials, it was discovered that Princeton had in fact an undergraduate course with similar goals. The course was adopted compete with texts and lectures and adjusted to the needs of Temple students. The course requires weekly reading assignments, weekly homework/problem set tasks, labs with write-up, a midterm and final exam, and a final written project with both a written and oral component.

Technological Transformations is designed to explain the origins and workings of many of the engineered devices and systems that comprise our modern world while imparting a sense of the nature of engineering science and its systems, e.g., electrical power system. The material begins with the first Industrial Revolution in Britain focusing on bridge and steam engine design. Following quickly are applications of steam engines in trains and boats. A defining moment is presented with the Lowell hydraulic powered textiles mills and their water wheels juxtaposed to the subsequent introduction of turbine technology incorporating modern engineering techniques and research. Units that define the basis of electrical power and application follow along with the materials of the US industrial development: steel and oil. Moving to the 20<sup>th</sup> century, aerodynamic design and flow principles are presented with aircraft and automobiles.

Key engineering concepts around which the material is organized include: concepts of work, force, energy (especially inter-convertibility), engineering and how it differs from basic science, how science and technology became more interwoven through time, and how engineers predict and measure phenomena.

Lectures are formulated to introduce the operative physical forces at work; the nature of the engineering problem; the nature of the creative design process and how the presented problem is framed in an engineering sense; the relative nature of materials and understanding of the phenomena in a particular time era; and the operative or constituent equations pertinent to each problem. This approach is reiterated for each chapter/thematic presentation. The accompanying problems sets are simplifications of the complex quantitative solutions but are geared to enhancing a quantitative understanding of problem solving. The qualitative questions are related to the quantitative aspects and force the students to conceptualize the phenomena and then explain the formula. The weekly problems are also assessed in the midterm and final exams which comprise both calculation and short essay response.

An illustrative example is Chapter 3 in the text, *Innovators, The Engineering Pioneers Who Made America Modern*, "Fulton's Steamboat and the Mississippi." The historic setting was the need for boats that could go upstream at a determined rate of speed. Fulton applied a Watt steam engine to his design and succeeded. Students are shown how Fulton used a variety of formulae to determine the size and necessary horsepower to drive his boat. Drag calculations, paddle power, paddle wheel area, thrust calculations are explained and outlined. An example of the correlative formulae is how Fulton calculated drag:

$D = pAC_D$  where  $p$  = water pressure,  $A$  = wetted area of paddle surface,  $C_D$  is the drag coefficient.

The subsequent evolution toward the smaller, more powerful high pressure steam engines fostered better understanding of the internal pressures. Boiler axial and circumferential stresses and their measurements are introduced along with new federal safety legislation. The operative equations associated with the new stresses are:  $f_2 = Pr/2h$  and  $f_1 = Pr/h$  where  $P$  = pressure,  $r$  = radius, and  $h$  = height.

The chapter problems alter the basic numbers in the presented equations and ask students to calculate new answers. An example for Chapter 3 is:

1. To secure the monopoly franchise for steamboat operation on the Hudson River in 1807, the State of New York set 4 mph as the minimum speed a boat had to attain. Calculate the drag that a Fulton steamboat would have experienced if the steamboat had a wetted area of 3,500 sq. ft. ( $A$ ) and the drag coefficient ( $C_D$ ) was 0.0022.

Labs are focused on a specific theme, e.g., conservation of energy and mass, parallel and series circuits, and aerodynamic flow. These are one class in length with a pre-lab set up and a post-lab explanation. Again the students are asked to take raw data and calculate a series of answers according to basic formulae. An example here would be the lab on conservation of mass and energy. A model car is released at one end of an elevated track, goes down, gathers speed, goes through a complete loop, exits the loop, and climbs to a stop. Students take a series of velocity measurements and determine the theoretical and actual potential and kinetic energies in the system. Related equations governing this lab are derived from the general equation:

$E = KE + PE + TE = ME + TE = \text{constant}$ : potential energy =  $PE = mgH$ ; and kinetic energy =  $KE = mV^2/2$ .

The final project is a research effort with a formal written essay based on peer-reviewed sources and a short PowerPoint presentation. Students choose a topic from a variety of areas, for example, future energy systems. They focus on a specific aspect of a problem, for example, solar power and the design of solar chips. The student must ask an engineering question and then do the necessary research to determine how the engineering problems associated with the topic are formulated, find the constituent formulae, and how subsequent applications and problems are being addressed. One key here is that they must be able to explain the associative formulae. The student effort on the final project is most rewarding as virtually all embrace the opportunity to examine something of interest to them. For example, one student this last semester, an art major specializing in textiles, explored the latest designs in air jet weaving machines and the engineering basis to their designs. She included several equations utilized in the design of these machines. One was the equation for friction force on the weft (thread):  $dF_f = c_f t + t + d_A$  where  $dF_f$  = elemental friction force;  $c_f$  = skin friction coefficient;  $t$  = shearing stress;  $d_A$  = circumfluent surface element; and  $D$  = weft diameter. In other words, there is something for everyone.

The justification for the course is illustrated by its ability to meet a wide range of the general and area requirements. The General Education learning objectives are covered in all areas.

Objective 1: quantitative and qualitative tasks in homework and problem sets develop critical thinking and communication skills

Objective 2: lectures, labs, reading, and research project to expand student's knowledge in subject area

Objective 3: discussion, reading, quantitative and qualitative tasks, and research project develop students' ability to make informed judgments

Objective 4: labs and research project promote intellectual curiosity and life-long learning

Objective 5: accompanying readings and research project develop skills in identifying, accessing, and evaluating sources of information

The class further reinforces the second level of goals as it follows a general chronological format and touches on more current issues. This is especially true for the research project.

Goal 1: the research project focuses exclusively on current technological issues.

Goal 2: the labs and research project enhances collaborative learning and team work.

Goal 3: The research project aids in an understanding of Temple's urban setting

Goal 4: The homework both quantitative and qualitative, the labs, and the research project develop students ability to analyze and interpret data.

Goal 5: The entire curriculum, especially the lectures, develop students' ability to identify and solve problems.

The course design also follows the format suggested in the Natural Science/Technology guidelines. Assessment follows multiple methods with significant writing exercises; experiential learning through labs and demonstrations. Competencies include: student understanding of engineering problem formulation, the role of quantitative measurement, inter-convertibility of energy; student ability to utilize relevant formulae; and an understanding of engineering methodology.

Student feedback has been positive on the course but through time many wearied of the emphasis on calculation-based problem sets. There was a two-pronged response. First, there was a shift to more qualitative questions in the weekly homework. Instead of having the students only answer a variation on Joseph Henry's use of a formula that determines the resistance in a coil,  $R = \rho L/A$ , students are instead asked to explain the formula relative to the forces at work, e.g., How does an electromagnet work; how do you measure the amount of potential work it can do? This was more challenging but it was good preparation for the essay questions on exams.

The second response was to build a list of supplementary articles that would allow the students to read and understand specific aspects of engineering problems. A series of



articles drawn from *Scientific American* post-1945 were assigned to the relative chapters. Each explores an aspect of a chapter in the text more succinctly. For example, one focuses on the Wright Brothers Flight Control System and another on De Forest and the Triode Detector. These articles are discussed in class so the students are taught how to critically read such articles. Quizzes were also given to insure that they did the reading and understood the main concepts presented. This shift certainly falls within the objective and goal regarding critical thinking and writing skills. The emphasis on conceptual writing on a weekly basis and the critical understanding of the articles lays an excellent basis for the stronger accentuation on both the midterm and final exam. The qualitative effort also prepares the students more acutely for the written final project.

These classes are primarily intended for freshmen and sophomores. As such, their skills are not always what you might expect. The old adage of assuming nothing is very true regarding this age group. When the shift from more quantitative to more qualitative took place it created an emphasis on article-based reading versus the textbook. Thus, a new skill area had to be addressed and calculated into the teaching matrix.

### The Bionic Human

A team comprised of Mohammad Kiani and George Baran from Mechanical Engineering and Solomon P. Samuel from Albert Einstein Medical Center developed the bioengineering-based course. The Bionic Human uses an inquiry based approach to explore current healthcare issues related to bioengineering. An important goal of this course is for students to become better healthcare consumers and be able, for example, to ask intelligent questions about their healthcare from their doctors. Again, no matter the material, students are expected to understand an engineering approach and the associated concepts. This area moves beyond the base scientific knowledge of physics, chemistry, and mechanics to human physiology which presents an entirely different array of problems for engineers. Nevertheless, the students are expected to learn the basic physical principles behind the operation of medical devices. As an example, the discussion on biomedical imaging systems starts with a presentation of the Lambert-Beer Law and its applications to living systems.

The major engineering concept is how multiple disciplines converge into bioengineering in order to resolve basic science/physiology issues and work toward ultimate treatment and device development. Utilizing scientific articles and review papers students will come to understand the challenging path toward development intertwined with government regulation and a host of ethical considerations. There are currently no textbooks available for a course such as this; available books on the subject are either written for experts in the field or at the very simplistic level for lay audience. A textbook based on this course is currently being written by the developers of the course.

Whereas Technological Transformations begins with a mechanical world derived from Newton and universal law, the Bionic Human sets a different standard. All engineering and scientific work begins and ends with human physiology. In other words, the body sets the standards and workplace criteria; all research, development, and

application must conform to this challenging environment, no exceptions. This is an excellent opportunity for students to understand the difficult path to success in bioengineering and the limitations that make the work so difficult, expensive, and lengthy. Hence, basic human physiology and pathology comprise each unit.

The class begins with health issues associated with aging: arthritis, vascular stenosis, etc. The next section includes a detailed discussion of various imaging modalities, including ultrasound, X-ray, CT, MRI, and contrast agents. A large section of the course, comprising almost 20% of the lectures, is dedicated to the discussion of the mechanics and physiology of the musculoskeletal system and biomaterials. This section is then followed by modules covering drug delivery systems, gene therapy, and medical devices. A few lectures present a brief overview of ethical and legal issues surrounding the use and application of medical technologies. Not surprisingly, the latter module attracts the most attention from students as it discusses issues such as the impact of technological development on cost of healthcare and end of life decisions.

Laboratories are an integral aspect of the course and include both hands on and virtual (computer based) assignments on tissue and biomaterial properties, surface treatments, drug coating, and cardiovascular effects of caffeine and energy drinks. In addition, in a discussion session students participate in a scenario where they pretend to work for a company that has to deal with the rising cost of health insurance. In this scenario, the employees (i.e., the students) are asked by the insurance company to undergo genetic testing and other procedures to determine their risk for certain diseases. The students then can see how their decisions may impact their future prospects for obtaining health insurance and employment.

Assessment is made through 3 multiple choice exams and a final research project focusing on a medical device or technology. The students are required to use primary sources to discuss the technical principles underlying the operation of the device, its clinical use, costs, and related social/ethical issues. Many of the questions in these exams require the students to analyze, rather than regurgitate, the information they have learned in class. For example, in the following question the students need to combine their knowledge of how X-rays penetrate various biological materials with their basic understanding of osteoporosis to come up with the correct answer (b):

If Mary has osteoporosis, what will be observed in X-ray images of her hip bones over time?

- a. The hip bone images appear lighter over time
- b. The hip bone images appear darker over time
- c. The hip bone images do not change over time
- d. The gray level of X-ray images has nothing to do with bone density

Justification for this unique course is based upon its ability to fulfill virtually all of the goals outlined in the general and area requirements. Additionally, the class consistently commands the attention of large groups of students. In Tech Transformations, many students find it interesting to actually learn what a transformer attached to a telephone pole is doing in front of their house but many more are attracted to

the inner workings of the human body and the technologies that are used to treat our illnesses.

Again, the General Education learning objectives are covered in all areas again in a mechanical engineering course.

Objective 1: quantitative and qualitative tasks in homework and problem sets develop critical thinking and communication skills.

Objective 2: lectures, labs, reading, and research project to expand student's knowledge in subject area

Objective 3: discussion, reading, quantitative and qualitative tasks, and research project develop students' ability to make informed judgments

Objective 4: labs and research project promote intellectual curiosity and life-long learning

Objective 5: accompanying readings and research project develop skills in identifying, accessing, and evaluating sources of information

The Bionic Human also reinforces the area level of goals especially in regard to current and ethically complex issues.

Goal 1: the research project focuses exclusively on current technological issues.

Goal 2: the discussion session fosters collaborative learning and teamwork skills.

Goal 3. The research project aids in an understanding of Temple's urban setting

Goal 4: The homework both quantitative and qualitative, the labs, and the research project develop students ability to analyze and interpret data.

Goal 5: The entire curriculum, especially the lectures, develop students' ability to identify and solve problems.

This course design also follows the Natural Science/Technology format. Assessment follows multiple methods with significant writing exercises; experiential learning through labs and demonstrations.

## Conclusion

The Department courses have fulfilled the requirements of the General Education Program Directive and enhanced Temple University student understanding of engineering. Table 1 illustrates the interest and success of the courses as seen in the numbers of registered students. Clearly the Bionic Human is a showcase class but Technological Transformations also holds steady numbers and has expanded through time.

Table 1: Registration for Mechanical Engineering General Education Courses

Academic Year	Tech. Transformations	Bionic Human
2007-2008	13	59

2008-2009	67	243
2009-2010	89	341
2010-2011	168	405
2011-2012 (projected)	240	500

Teaching non-engineers, many of whom have only rudimentary math skills, the complexity of design and calculable phenomena, is what we call in the trade a teaching challenge. ABET has inculcated the concept of self-reflection and addressing how we succeed in teaching base concepts. Grades and student feedback are neither always sufficient nor accurate in determining teaching success. Instructors must take an active, critical role. Accordingly, each of these courses have been analyzed regarding key conceptual elements and refinement has taken place, further verifying that teaching is an evolutionary process based on more than the internal shifts that come with inculcating new research.

Engineering has an important, integral knowledge base that can be made available to a broader audience while fulfilling general education requirements. It can be argued that the modern world from the pyramids at Giza to our modern communication system has been shaped by engineers. Yet, few understand what the term means. Engineers can fill this vital gap by taking the initiative and reaching out beyond their academic boundaries.

## Bibliography

1. General Education at Temple University: "Dare to Know!" Temple University, 24 Oct 2005.

## **Undergraduate Research Through NASA Initiatives**

GAFFAR GAILANI, PH.D

Dept. of Mechanical Engineering and Industrial Design Technology (DMEIDT)  
New York City College of Technology

Dr. Gailani is an assistant professor in the DMEIDT received his Ph.d in Mechanical Engineering from the City University of New York in 2009. His research work is focused on poroelasticity and its application in biomechanics. He has more than 15 journal publications and conference proceedings and one book.

SIDI BERRI, PH.D

Dept. of Mechanical Engineering and Industrial Design Technology (DMEIDT)  
New York City College of Technology

Dr. Berri is a professor and chair of the DMEIDT. He has MS and Ph.D in Mechanical Engineering from NYU Poly in Brooklyn. His expertise is in Manufacturing, Robotics and Computational Mechanics.

NIEVES ANGULO, ED.D

Mathematics Dept. Hostos Community College, Bronx, New York is an Associate Professor in the Mathematics Department and the Coordinator of the Engineering Program in the department. She has a pure B.A. and M.A. in Mathematics from Hunter College of CUNY, and an M.S and Ed.D in Mathematics Education from Columbia University. She has been very active in externally funded initiatives dedicated to improve proficiency in STEM education including collaborative projects with NSF, DoE and NASA.

# Undergraduate Research Through NASA Initiatives

## Abstract

There was a common belief that research should only be introduced at the graduate level or at least the senior undergraduate year. Research in the freshman year was not even a topic for discussion. Today, throughout the City University of New York, colleges are stepping forward and conducting research at all undergraduate levels and achieving good results. Conducting research as part of an internship or with a faculty member, proved to be one of the most effective ways to enhance the skills of the students in STEM by many authors. The department of Mechanical Engineering and Industrial Design Technology at New York City College of Technology, City Tech, has been focusing on research in the undergraduate level in the last three years in order to improve the quality of its graduates. The project started by half of the department faculty members who collaborated with Louis Stokes for Minority Participation in STEM, LSAMP, to implement research activities in freshman and sophomore classes. The work went further when the department obtained two major grants, NSF ATE and NASA CIPAIR. The NASA CIPAIR project is focusing in involving students in NASA and aerospace research in their early stages in college through building partnership with NASA. The project allows students to work in NASA active projects and faculty to collaborate with NASA scientists. Curriculum enhancement to include aerospace relevant material is a part of the project. A new course in Remote Sensing has been introduced as well. On the other hand, collaboration is built with Hostos Community College to allow the engineering students from Hostos to transfer to City Tech to get their bachelor degree in engineering technology. An articulation agreement between both colleges will enhance this transfer. This project represents the most critical, logical step in City Tech's long-term plan to transform itself to a model institution for the education of under-represented students in STEM majors. The project is filling a critical gap in the engineering technology program offerings by making it more relevant to current industry needs (e.g., NASA) and creating curriculum and learning experiences for students that do not currently exist. Strategically, this project is another key piece in the college's effort to overhaul and upgrade all its science, technology, engineering, and mathematics programs. The three years project will raise graduation and retention rates and prepare students to be the future workforce of NASA.

## Introduction

In the past there was a common belief that research should only be introduced at the graduate level or at least the senior undergraduate year. Research in the freshman year was not even a topic for discussion. Today, throughout CUNY, colleges are stepping forward and conducting research at all undergraduate levels and achieving good results. One of the more effective ways to enhance the skills of the students in STEM is conducting research as part of an internship or with a faculty member, Boyd and Wesemann (2009). Rising Above the Gathering Storm (RGS)<sup>a</sup> report in 2007 warns about the relative decline in the United States in the science and technology market place and that the competitive nations had increased public funding for research and development making significant investments in higher education. The report included many statistical studies such as:

<sup>a</sup> Rising Above the Gathering Storm: Energizing and Employing America for a Brighter Economic Future. National Academy of Science, ISBN 0-309-65442-4, 592 pages (2007).

<sup>a</sup>Office of Assessment and Institutional Research at City Tech

- 1- The United States graduates more visual arts and performing arts majors than engineering.
- 2- We are ranked 27<sup>th</sup> among developed nations in the proportion of college students receiving undergraduate degrees in science or engineering.
- 3- In year 2000 the number of foreign students studying the physical sciences and engineering in United States graduate schools for the first time surpassed the number of United States students. RGS report recommended doubling the federal investment in basic research.

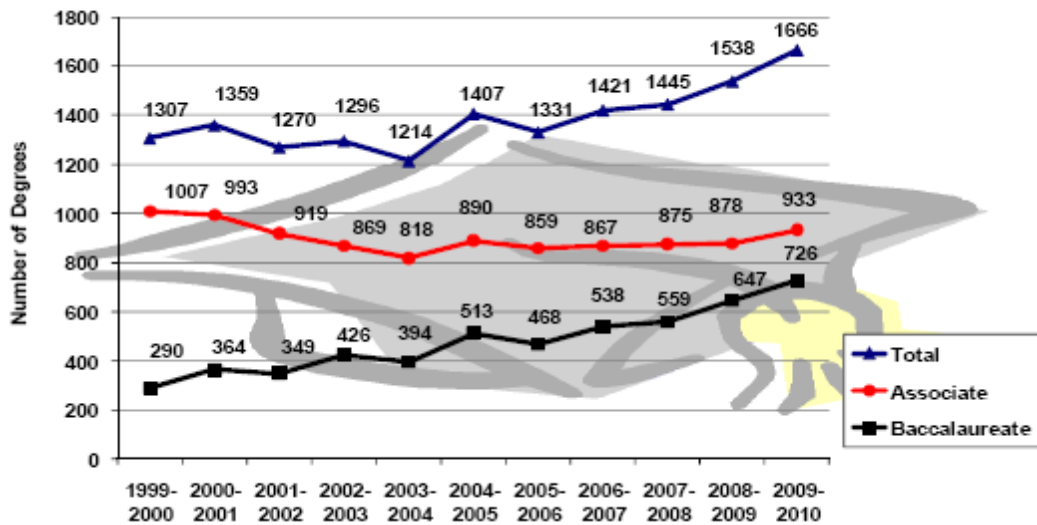
Critical areas within the education strategic frame work and the issues that are facing the nation and outlined in the *Rising above the Gathering Storm Report* need to be addressed. While this report addresses the problem for the whole nation, the weakness in higher education will be more severe for minority communities. City Tech was one of the colleges which participated in the Model Institution of Excellence (MIE) program. The MIE report described seven components proved to be successful. Six of these components are aligned with the particular needs of City Tech at the moment. The components are: (1) pre-college initiatives and recruitment (2) student development and support (3) undergraduate research and professional training (4) faculty development and enhancement (5) curriculum development (6) physical infrastructure development and renovation.

#### About City Tech

City Tech is the designated senior college of technology within the 23-campus City University of New York, CUNY, the largest urban public university system in the nation. A federally designated Hispanic Serving Institution (HSI), City Tech has a student population of 15,368. 34% of students identified themselves as Black (non-Hispanic), 31.7% as Hispanic, 18.5% as Asian/Pacific Islander, 11.0% as White, 0.5% as Native American, and 5.4% as Other. Sixty-eight percent are the first in their families to attend college<sup>a</sup>. Students enter with widely disparate levels of academic preparation, professional goals, and personal circumstances. As an open access institution, City Tech's historic mission has been to offer opportunities for educational advancement to students regardless of financial circumstances or prior academic achievement. City Tech plays an important role nationally in the education of future scientists, engineers, technologists, and mathematicians as shown in Figure 1. The figure shows a clear increase in enrollment and the number of students who earn a bachelor degree over the last three years.

In the Fall 2009 Fifty-two percent (52%) reported a household income of less than \$30,000. Seventy-six per cent (76.8%) of incoming first-year students and 60% of returning students received need-based financial aid. The student body, which is more than 15,000 members, reported more than 134 countries of origin; countries of origin of faculty also span the globe. Thirty-five percent (35%) of students reported working 20 or more hours per week<sup>b</sup>.

<sup>b</sup> New York City College of Technology (CUNY) Office of the President. Facts 2009-2010.



**Figure 1:** Number of degrees awarded at City Tech from 1999 – 2010. (Source: Office of Assessment and Institutional Research at City Tech)

About the Mechanical Engineering and Industrial Design Technology Department (MEIDTD)

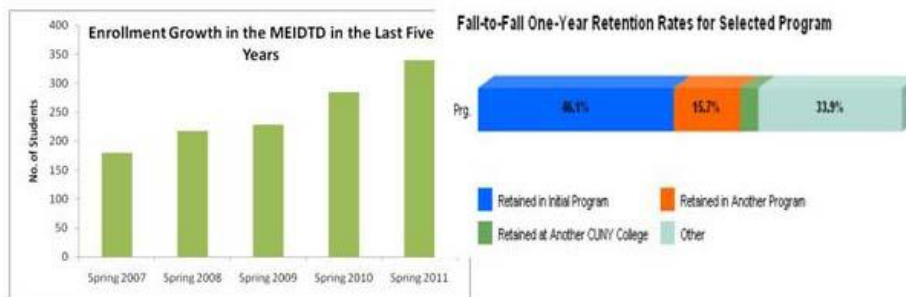
The MEIDTD is a fast growing department. The department started offering a bachelor’s degree program in Industrial Design in Fall 2010. The increase in enrollment from Fall 2006 to Fall 2010 is 50.4%. As of Spring 2011 the department has 340 students as shown in Figure 2. In the associate degree program 28% of the students are African American and 27% are Hispanics, in the baccalaureate program, 28% of the students are African American and 12% are Hispanics. The data shows clearly that a lower percentage of minority students continues to the bachelor degree level, despite the high population of minority students in the associate programs. The challenge for the department is to match this fast growth in enrollment with the quality of education in engineering that will help in retaining the students so that they continue to the bachelor level which will increasing the graduation rate.

The graduation rates in the School of Technology and Design are not impressive as shown in Table 1. Retention rates are still low as shown in Figure 3. The data justifies the need to improve the curriculum to retain students in the program. A retention rate of 46.1, shown in Figure 2, is still low for a department with this high number of students. Last year, 2010, the MEIDTD received two grants: an NSF Advanced Technology Education (ATE) to establish a mechatronics center, and an NASA CIPAIR grant to build a partnership with NASA. The demand for qualified graduates especially in this area of mechanical engineering is very high.

The Mechanical Engineering Technology Department at City Tech is one of the leading departments in engaging students in research. In the fall of 2011 the enrollment has doubled to what it was five years ago. Four students from the department received awards to present their research work at national conferences in the last two years. In the summer of 2009 three students from the department worked with Dr. Gaffar Gailani, in a collaborative project with the department of Biomedical Engineering at City College (CCNY) and were able to publish their work (Ranglin et al., 2009). Involvement of students in research and internships has



proved to be very motivating. The department started to offer a bachelor's program in the Fall of 2010 with registration already showing high enrollment.



**Figure 2:** The growth in enrollment in the MEIDTD from 2007 - 2011, Left. Fall to Fall one-year retention rates for MEIDTD as spring 2010, Right. (Source: Office of Assessment and Institutional Research at City Tech)

The above examples represent the work of individual students and small teams only. In order to involve more students in research work the primary author received two consecutive awards (2008 and 2009) for Integrating of Research Strategy (IRS). The basic idea of the IRS is to introduce research to *first-year* students in a specific course and evaluate the effectiveness of the new approach. Some of the results were published in Gailani et al. (2009) and Gailani et al. (2008). The IRS revealed the following:

- 1) Students feel more confidence when they work in teams and they produce better results. In a response to a survey question about team work in the IRS course, 73% of the students responded that team work was extremely helpful in the IRS course.
- 2) Students (freshmen) show less confidence and interest in report writing. This might be an indication of the deficiency in their writing and analytical skills.

A good example of the impact of doing research at the undergraduate level is Mark Nelson, whose GPA was fluctuating between 2.5 and 3.0 during his first two years in the computer engineering technology program at City Tech and *he thought of himself as an average student. As soon as he joined the Louis Stokes Alliance for Minority Participation in STEM, LSAMP, his education experience changed for the better. He was named to the Dean's list every succeeding semester until graduating with honors in June 2010.* Today he has been accepted for graduate study in robotic engineering at Worcester Polytechnic Institute in Massachusetts. This tells us we can inspire this generation to move forward if we give them the opportunity.

#### Goals of Building Partnership with NASA

(3a) Articulation with between Hostos Community College (HCC) and City Tech.

HCC engineering program is located within the Math and the Natural Science Departments. It was established in 2003 by Dr. Nieves Angulo, to meet the needs of the growing number of minority students who are interested in pursuing a career in engineering. The purpose of the program is to offer the first required two years in Mechanical, Electrical, Civil and Chemical engineering to students planning to enter and continue studies in those fields. The program has grown rapidly since it began in 2003 with fewer than 10 students to reach 164 students in the Spring of 2010, making it one of the fastest growing programs at HCC. Enrollment has increased 41.2% from the spring 2009.

For the same period the increase in the enrollment in the associate degree programs in liberal arts and science was only 14%. The transfer rate from the engineering program to 4-year colleges is less than 20%. This collaboration between HCC and City Tech is laying the foundation for multidisciplinary collaboration between engineering technology and the sciences at City Tech and the engineering program at HCC. The departments on both sides are working on articulation agreement to ease the process of student transfer to the 4-year programs at City Tech.

<sup>c</sup> New York City Alliance News, Fall 2010, page 7.

(3.b) To improve curriculum by updating existing courses and introducing two new courses: The project has a big impact on the curriculum through the revision and updating of 5 existing courses at City Tech and HCC. The project will result in

- i. Developing curriculum for two *new multidisciplinary* courses “Introduction to Research Management”, and “Special Topics in Remote Sensing”.
- ii. Updating and revising six courses to incorporate NASA-relevant material (4 courses at City Tech and 2 at HCC); the courses will be detailed in the next section.
- iii. Acquiring a limited amount of engineering laboratory equipment to support the new course and the revised courses.
- iv. Overall, improving the quality and content of the offerings at City Tech and HCC.

(3.c) To enhance students’ skills in research. The project helps students in developing their research skills, thus raising the performance of the students and making them a model for future students. Students are trained to do research and participate in internships. The experience gained by students will be used to improve the courses. Thus, *students will participate in the curriculum committees for selected courses.*

(3.d) To Improve and strengthen the engineering program through partnership with NASA centers and other industries. A partnership is built with NASA Goddard Space Flight Center in MD, Marshal Space Flight Center in Alabama, New York City Research Initiative (NYCRI) which is supported by NASA Education Office. Ten students at least are sent every year to participate in summer internships in addition to two faculty members, one from HCC and one from City Tech.

(3.e) To strengthen faculty development and exposure to NASA research areas and opportunities. Faculty members are exposed to NASA opportunities and research areas. Appropriate faculty members gain valuable knowledge about NASA and relevant areas through visits, seminars, training, participating in curriculum development, and mentoring students.

(3.f) To raise the transfer rate to City Tech, graduation and retention rates. The improved curriculum and the partnership with HCC will result in an increase of transfer of students from HCC in particular, to the 4-year programs at City Tech. Partnership with NASA is helping in retaining these students at City Tech, thus automatically improving the graduation rate. Involvement of students in activities such as research work and internships proves to be very helpful in motivating them to succeed in their discipline. *The goal is to reach a graduation rate of 50% by June 2013.* The current retention rate for City Tech is 44%. The goal is to increase the retention rate to 65% by the summer of 2013.

(3.g) To build Multidisciplinary collaboration and articulation agreements. This collaboration between HCC and City Tech will lay the foundation for multidisciplinary collaboration between engineering technology and the sciences at City Tech and the engineering program at HCC. The

departments on both sides will work on articulation agreements to ease the process of student transfer to the 4-year programs at City Tech.

(3.h) To prepare the students to be the future work force for NASA. The exposure that students are gaining through internships at NASA centers, conducting research that is relevant to NASA and improved curriculum with NASA relevant materials will lead to a better preparation of our students to be the future work force for NASA or one of its contractors. These are all in line with NASA stated goals and objectives.

(3.i) To extend the effort to include high schools as the pipeline for STEM. This project includes a high school component in it to assist high school students to enroll in STEM and link them with college students, thus allowing a unique interaction and exchange of experience. This work is initiated by collaboration with Proyecto Access program which is located at HCC. Proyecto Access is a Pre-Freshman engineering program.

(3.j) To encourage students-faculty STEM research teams. Faculty are encouraged to conduct research work with selected students during the academic year. This will expose students to research and give them out-of-curriculum expertise. STEM faculty members are encouraged to participate in the Integrated Research Strategy (IRS) which is monitored by LSAMP. IRS encourages faculty to integrate research component in the courses they are teaching. 70% of the faculty of the Mechanical Engineering and Industrial Design Department have applied for IRS 2010.

## Results

The results for the first year of the project were very impressive. A professional evaluator, Joy Quill Assoc., is hired to evaluate the project progress and assess the improvement. Surveys were conducted by the evaluator and the project directors to measure the strength and address the deficiency. After one year we have accomplished the following

- 1- Ten students worked in the summer of 2011 in Goddard Space Flight Center, Marshal Space Flight Center, and NYCRI. Two faculty members worked with students in NASA Goddard Center in MD, and Marshal Flight Center in AL.
- 2- The new multidisciplinary course in Remote Sensing, EET3132, is approved, and will be offered for the first time in the fall of 2011. The new course of Project Management, IND4750, is offered in the fall of 2011. This course was approved as part of the bachelor program package. The Computer Applications in Mechanical Engineering Technology course, MECH1240, has been updated and tested in the spring of 2011. The response of students was evaluated through two surveys. Update of the Materials Testing course, MECH2426, and Simulation and Presentation, IND2420, with NASA relevant material will start in the academic year 2011 – 2012.
- 3- Campus Activities: The first Research Summit in July 2011 which was attended by nearly 200 guests, including students from different universities and programs, faculty members and invited guests was a total success. The summit highlighted research activities of students during the academic year 2010 – 2011 and summer 2011 in different internships including NASA. Many programs were involved such as NASA NYCRI, LSAMP, REU, NSF-I cube, NASA CIPAIR, CUNY/GSFC HEC & CUNY/GISS CGCR. The keynote speaker was from NASA. Students gave oral and poster presentations that featured their research work.
- 4- Workshops:

*The pre-internship Workshop:* This one day workshop was to prepare students psychologically for internship. All students who were selected for internship in NASA CIPAIR, LSAMP, and NYCRI were asked to attend this mandatory workshop. Most of these students were doing their internship outside their campuses (NASA, Brookhaven National labs, and NYCRI). The workshop included all details of how to communicate with mentors, how to perform the work, how to act on the site, things should not be done in the internship...etc. More than 22 students attended the event and a survey was given at the end to measure how students were able to digest the material covered.

*The Internship Workshop:* The work hosted many speakers two of them were Co-PIs of NASA CIPAIR in addition to the director of the New York City Research Initiative. More than 30 students attended the workshop

- 5- Website: A website has been built to disseminate the project activities and recruit students for STEM. The website link is available at Citytech website and at [www.cipairnasa.com](http://www.cipairnasa.com).
- 6- Project Evaluation: C. J. Quill & Associates, Inc. was hired to evaluate the project. The head of the firm, Joy Quill, who has prior experience evaluating NASA STEM-related programs, is serving as the evaluator. Ms. Quill played a major role in the IRB approval process to conduct surveys in both campuses. IRB approval was secured in May 2011, allowing for the conduct of an online survey of City Tech and Hostos engineering and pre-engineering students before the end of the academic year. The purpose of the survey was to obtain baseline information on students' knowledge of and interest in NASA-related engineering education and careers. Demographic information was also requested. The evaluator is also conducting a process review of the first year's activities, which involves document review as well as interviews with many faculty and administrators involved in the project. A detailed evaluation report will be submitted by the evaluator before the end of August.
- 7- Progress at HCC: articulation agreement between City Tech and HCC that will make it easy for HCC students to transfer to City Tech to finish 4-year degree in engineering is almost complete. Four students from Hostos participated in summer internships this year. Two students accompanied Dr. Angulo to Alabama to summer internship in Marshal Space Flight Center. The other two students worked with NASA NYCRI with Goddard Institute of Space Studies scientists. Collaboration started with the Proeyctoaccess program which is nested in HCC. Proeyctoaccess organizes intensive summer programs for high achieving minority students who want to pursue careers in engineering and science. This summer NASA CIPAIR helped the robotic class in Proeyctoaccess acquiring some equipment for the students to use and next summer Dr. Vaninsky from the math department at HCC will design some robotic curriculum to be taught. HCC organized the Dynamic Women leadership Forum with guest speaker from NASA, Monserrate Roman the chief microbiologist in Marshal Space Flight Center.

### Summary

This project represents the most critical, logical step in City Tech's long-term plan to transform itself to a model institution for the education of under-represented students in STEM majors. The project will fill a critical gap in the engineering program offerings by making it more relevant to current industry needs (e.g., NASA) and will create curriculum and learning experiences for students that do not currently exist. Strategically, this project is another key piece in the college's effort to overhaul and upgrade all its science, technology, engineering, and mathematics programs. This project is affordable, measurable, and worth doing for the significant benefits it will bring to under-represented students and faculty.

## **Acknowledgment**

This work will not have been possible without the grant of NASA CIPAIR NNX10AU73G and our partners at NYCRI and CUNY-LSAMP.

## **References**

- Boyd, M., and Wesemann J., 2009. “ Broadening participation in undergraduate research: fostering excellence and enhancing the impact.” Council on Undergraduate Research (CUR)
- G. Gailani, M. Benalla, R. Mahamud, S. Cowin, and L. Cardoso, 2009. “Determination of the permeability of the lacunar canalicular porosity”, ASME J. of Biomech. Engr, v131-10, pp101007 (7pages).
- Ranglin, S., Das, D., Mingo, A., Ukinamemen, O., Gailani, G., Cowin, S., and Cardoso, L., 2009. “ Development of a mechanical system for osteon isolation”. Proceedings of the ASEE Mid-Atlantic Conference, PA, Oct. 2009.
- Shaul R, 2010. “ Mechanical Engineering Technology Major Encourages Other students to Participate in Research Conferences”. An interview with Shaul Ranglin. City Tech News, available at [http://www.citytech.cuny.edu/aboutus/newsevents/2010sp/mech\\_ranglin/index.shtml](http://www.citytech.cuny.edu/aboutus/newsevents/2010sp/mech_ranglin/index.shtml)

**The Development of an Alternative Energy Minor at  
Robert Morris University**

Tony Kerzmann  
Assistant Professor  
Robert Morris University  
6001 University Boulevard,  
Moon Township, 15108

Gavin Buxton  
Assistant Professor  
Robert Morris University  
6001 University Boulevard,  
Moon Township, 15108

Maria V. Kalevitch  
University Professor of Biology &  
Dean of the School of Engineering Mathematics and Science  
Robert Morris University  
6001 University Boulevard,  
Moon Township, 15108

# **The Development of an Alternative Energy and Sustainability Minor at Robert Morris University**

## **Abstract**

Energy experts have identified seven energy sectors as strategically important for the economy of the United States. These energy sectors are: coal, natural gas, nuclear, solar, wind, transmission & distribution and intelligent building. Along with Chicago and Detroit, Pittsburgh is among the only three cities in the nation with high employment across all of these seven energy sectors. Additionally, Pittsburgh is the only city that also resides on a natural resource base of coal and shale gas fields. In consideration of the existing energy activities in the Pittsburgh region, these energy sectors are addressed in the School of Engineering Mathematics and Science (SEMS) energy curriculum. In the fall semester of the 2010 school year at Robert Morris University, SEMS began laying the groundwork for what is now an alternative energy minor. This is an interdisciplinary minor that was developed through the combined efforts of engineering and science faculty. The curriculum was based on the currently available expertise in environmental science and engineering. The initiative began as a collaborative effort and after multiple meetings and the consent of the university registrar; the minor was offered to the students and has achieved a very promising enrollment in the first semester of its offering. The alternative energy minor is comprised of three capstone courses and two elective courses, totaling 15 credits. The minor also has two tracks, one tailored to SEMS students and another which has a background in business sustainability. These two tracks open this minor to the entire student population at RMU. This paper discusses the steps taken to enact the minor, as well as the lessons learned in the course development process. In particular, the classes currently offered as part of the minor are discussed and the reasons for developing these courses are detailed.

## **I. Introduction**

The School of Engineering, Mathematics and Science (SEMS) was founded in 1999 by building on the existing Department of Quantitative and Natural Sciences. Undergraduate offerings from the Engineering Department currently include an ABET accredited B.S. in Engineering (tracks in Software, Industrial, Mechanical and Biomedical Engineering) and a B.S. in Manufacturing Engineering. The department also offers an M.S. in Engineering Management. Mathematics offerings currently include B.A. and B.S. programs in Applied Mathematics including a very successful Mathematics Education program, Finite Mathematics and a B.S. in Actuarial Science, which is an advanced and rigorous program. The Actuarial Science degree is accredited by the Society of Actuaries and RMU is among 10 institutions in the nation that is recognized as a Center for Actuarial Excellence. Science offerings include a B.S. in Biology, both B.S. and B.A. programs in Environmental Science, a Biology Teacher Certification program and a Pre-Medicine program.

Two minors are also offered. One in forensics and our new interdisciplinary minor in Alternative Energy and Sustainability that is the subject of this article. Industrial and

educational outreach is accomplished through the SEMS Research and Outreach Center (ROC) which has an extensive outreach program to middle and high school communities.

To emphasize the endeavors and desire for excellence within our school, we include our school's mission statement:

“The School of Engineering, Mathematics and Science will prepare engineers, mathematicians and scientists for leadership roles in a rapidly changing world. Our graduates will benefit from a professionally focused, applied education, derived through active classroom learning, laboratory experiences and cooperative education alliances with industry.”

The school offers graduate and undergraduate degrees showcasing the best of Robert Morris University's practical, real-world philosophy of engaged and applied learning. In biology, environmental science, pre-medical, mechanical engineering, and mathematics, our faculty are experts in their fields.

Close ties to the business world allow our students to tackle real problems under the guidance of their professors. Internships and research are key to our curriculum, helping our graduates gain subsequent employment. Students work with sophisticated lab equipment, such as our 7,500-square-foot Engineering Learning Factory and dedicated science laboratories in physics, chemistry, biology and environmental science. RMU's focus on communication and business skills gives graduates an advantage in the job market. All of our students enjoy small class sizes and personal attention that make RMU a special place to learn.

It is this interdisciplinary background and strong vocational emphasis, along with Pittsburgh's status as a future energy capital that makes RMU the ideal environment for training our future workforce for careers in the alternative energy sectors, and providing local employees with science and business graduates with a strong background in environmental issues and sustainability.

On a recent visit to Pittsburgh, President Obama outlined the importance of energy [1]:

“The time has come, once and for all, for this nation to fully embrace a clean energy future. Now, that means continuing our unprecedented effort to make everything from our homes and businesses to our cars and trucks more energy-efficient. It means tapping into our natural gas reserves, and moving ahead with our plan to expand our nation's fleet of nuclear power plants. It means rolling back billions of dollars of tax breaks to oil companies so we can prioritize investments in clean energy research and development.”

Obama's words ring loud and clear in the Pittsburgh area. There has been an economic boom in the Pittsburgh area that is directly related to the Marcellus Shale natural gas wells.



In a recent study done by researchers at Penn State University, Marcellus Shale drilling has led to 44,000 jobs in the Pittsburgh region and has generated about \$3.9 billion dollars in economic activity in 2009 [2]. The increased emphasis in energy has led to substantial industry activity and an emphasis on green jobs in the region. According to the 2010 Milken Institute Best-Performing Cities Index, which ranks U.S. metropolitan areas by how well they are creating and sustaining jobs and economic growth, Pittsburgh was ranked 32<sup>nd</sup> in 2010, up 77 spots from 2009 [3]. Pittsburgh's emphasis is not only on creating jobs, but creating green communities and cleaning up the city. Pittsburgh is the home of the first green Leadership in Energy and Environmental Design (LEED) certified convention center (David Lawrence Convention Center) and conservatory (Phipps Conservatory) in the world, as certified by the U.S. Green Building Council [4]. In fact, as of 2010, there were 54 green buildings throughout the city, making Pittsburgh the 4<sup>th</sup> ranked city in the nation in the number of green buildings [5].

With a city-wide emphasis on sustainability, RMU has decided to do its part in educating our future workforce to increase their environmental knowledge and awareness. Through the development of a new minor in Alternative Energy and Sustainability and in addition to existing educational and outreach programs, RMU is doing its part to meet the objectives of the students and their future employers. The purpose of this paper is to detail the structure and design decisions in developing our new minor. In addition, a breakdown of the courses taught within this minor and the reasons for choosing these particular courses for inclusion are provided. The emphasis throughout this process, as reflected in the resultant minor, is the interdisciplinary collaboration between science and engineering faculty to create a broad program capable of addressing our future societal needs.

## **II. Structure of Alternative Energy and Sustainability Minor**

The Alternative Energy and Sustainability minor is comprised of a total of 15 credits. The first 9 credits of the minor consist of three core courses which are required by all students pursuing this minor. Two of the core classes offer an introduction to the issues of energy generation and our future sustainability, while discussing the role of technology in addressing these issues. The final core class is a capstone class in which expert speakers are invited from the campus community and the Pittsburgh region to address topics following a particular alternative energy course theme. The students are required to complete an undergraduate research project that is related to this theme.

The remaining 6 credits that students are required to complete as part of the minor are chosen from a number of upper-level courses focusing on specific areas of expertise in both science and business disciplines. This increases the accessibility of the minor to the wider RMU community and introduces alternative energy and sustainability to non-science students.

The courses which constitute our minor are included in Table 1.

### Core Courses

ENVS/ENGR 1022	Energy Fundamentals and Sustainability
PHYS/ENGR 1023	Alternative Energy Technologies
ENVS/ENGR 4112	Energy Research Seminar

### SEMS Elective Courses

ENVS/ENGR 2012	Renewable Resources
ENVS/ENGR 3022	Energy Storage, Conversion and Transportation
GEOL/ENGR 4022	Conventional Energy: Fossil Fuels

### Business Elective Courses

MGMT 3850	Business Governance and Corporate Social Responsibility
ECON 3060	Environmental Economics
MGMT 3750	The Sustainable Organization
MARK 4700	Sustainable Marketing

*Table 1. A list of the interdisciplinary courses which comprise the Alternative Energy and Sustainability minor.*

The precise choice of courses was considered, after much deliberation and discussion, to be the optimum structure to meet the goals and objectives of the minor for students that are not only science or engineering majors, but for the entire student body. The details of these courses are listed below.

### **III. Course Details**

Included is a detailed description of the topics covered in each of the courses that comprise the core of the Alternative Energy Minor as well as the elective courses offered by SEMS.

#### **III.1. Energy Fundamentals and Sustainability**

The Energy Fundamentals and Sustainability course is an introductory course that focuses on energy production and use throughout the residential, commercial and industrial sectors. The course educates the students on the different types of energy streams and the current energy sector breakdown on a local, national and international level. Students are also introduced to sustainable energy production, including photovoltaic, solar thermal, wind powered, hydro powered and geothermal energy generation. This course includes

discussions about the potential environmental, political and socioeconomic ramifications of continued conventional energy generation as well.

### **III.2. Alternative Energy Technologies**

This course endeavors to elucidate recent and future developments in alternative energy technologies. In particular, this course covers recent scientific developments and the latest technological advances in areas of science and engineering associated with power generation. Students develop the necessary skills to quantitatively decipher scientific articles and to qualitatively interpret the scope and conclusions of recent scientific research. Subjects covered in the course are drawn from recent scientific breakthroughs, aimed at improving the cost-effectiveness and practicality of renewable energies. The strength of this course as part of the minor lies in its ability to motivate students about the contemporary science and research behind alternative energy, and to emphasize to students that new scientific breakthroughs are always occurring within the research community.

### **III.3. Energy Research Seminar**

The Energy Research Seminar is the capstone course for the Alternative Energy Minor and is taken by juniors or seniors. The course focuses on current issues of importance in the Alternative Energy field. Expert speakers from the campus community and the Pittsburgh region address topics following a particular course theme selected by the instructor. Students are expected to review and critically discuss selected articles and have the opportunity to serve as discussion leaders during the semester. Each student prepares a research paper or conducts undergraduate research on a specific topic, either of their own choosing or assigned by the instructor, which is aligned with the Alternative Energy theme of the course.

### **III.4. Renewable Resources**

This course provides a comprehensive overview of renewable energy technologies including: biofuels, geothermal energy, hydroelectric power, hydrogen fuel cells, solar energy (active and passive), tidal power, and wind energy. The types of energy and potential uses from each energy source are covered. The energy budget and overall efficiency of a wide variety of renewable energy sources are calculated. The economic, social, and environmental impacts of each technology are also considered.

### **III.5. Energy Storage, Conversion and Transportation**

This course introduces conventional and renewable mechanisms for the transfer and storage of electrical energy. The course beneficially integrates class presentations and hands-on demonstration activities. The topics include: electrochemical storage systems and related power densities; super capacitors, lithium batteries, fuel cell systems, proton exchange membranes, fuel cell stacks; basic principles of operation and future development needs; materials for energy storage and conversion; conventional lead-acid,

zinc-air, nickel-cadmium and nickel-metal hydride batteries; fuel cell architectures and electrode life times; purely ionic conductors; mixed ionic / electronic conductors; ionic transport, conductivity in polymers; AC to DC and DC to AC transformers and electrical circuits; economics of energy storage and conversion.

### **III.6. Conventional Energy: Fossil Fuels**

This course is a review of the three major fossil fuels: coal, oil and natural gas. It includes an in-depth review of the geological processes responsible for the formation of conventional fuels, including the national and international distribution of these fuels. The combustion process as related to fossil fuels is discussed, as are the techniques and technologies utilized in the exploration, use and environmental remediation of the fuels. The history of the industry devoted to exploration and use of these fuels is discussed. The effects of these fuels on climate change is also included in the course review. Non-conventional fossil fuels are also discussed including Marcellus Shale exploration.

### **Development of the Alternative Energy and Sustainability Minor**

In a political climate where national news channels openly attack the scientific community, and leading political figures read excerpts from the bible in congress to “disprove” the scientific consensus on global warming, science education is crucial if the United States are to lead the world in both developing alternative energy technologies and reducing greenhouse gas emissions [6]. However, not only is alternative energy and sustainability important from a national perspective, but Pittsburgh as an energy capital will play a large role in the development and application of renewable energies (as well the uses of conventional energy sources, such as the large reservoir of natural gas within the Marcellus Shale). Therefore, in addition to existing educational and outreach programs at RMU, a new minor in alternative energy and sustainability was proposed to better prepare our students for a future workforce in clean energy and green jobs.

It is worth noting that RMU in particular is well suited to the development of such interdisciplinary programs. The Science Department within the School of Engineering Mathematics and Science (SEMS) houses a diverse range of faculty including a chemist, a geologist, an environmental scientist, three biologists and a physicist. Furthermore, the Science Department within RMU is also closely associated with the Engineering Department, which also includes a diverse range of expertise within the engineering disciplines including manufacturing, nanotechnology, renewable energy sources, and energy storage technologies. The close relations between the Science and Engineering Departments within SEMS led to this new interdisciplinary minor and remain its largest strength. Many of these courses were developed with input from a number of different faculty from both the Engineering and Science departments, and the minor continues to draw from this diverse pool of expertise.

The six courses that are currently part of the minor were chosen for multiple reasons. The first reason, is that the courses should encompass a broad spectrum of topics from life cycle assessment and sustainable design to specific renewable resources. One of the purposes for

introducing the students to a full spectrum of alternative energy topics is to broaden their fundamental knowledge in the area, and to make the students more attractive to a wide range of future employers. Another important reason for the exposure is to foster interest in more specific area of the students' choosing which could lead to future graduate level research projects. Although RMU does not currently have a graduate level alternative energy program, preliminary discussions seem promising and the inclusion of a graduate program is in the near term goals for SEMS. A broad spectrum of courses was an important aspect of the development process, but another aspect that was equally important was the expertise of our faculty. Because the development process included the input of the faculty in the engineering, mathematics and science departments, we were able to take into account the views and expert opinions of faculty from a multitude of backgrounds. This diversity lead to a course selection that was tailored toward the faculty knowledge and strengths.

The exact structure of the minor was established, along with the detailed course contents at a SEMS retreat held on October 8<sup>th</sup> 2010. In particular, 18 members of faculty from the Engineering, Mathematics and Science departments were all present at the retreat. The retreat consisted of two components. The first part consisted of a discussion on the overall structure and design of the minor, at which point the 6 courses which constitute the minor were decided upon. Not only do these 6 courses provide an excellent balance between science education in alternative energy and sustainability in the core classes, but the upper-level electives provide a comprehensive overview of our energy requirements in the 21<sup>st</sup> century.

The second component of the retreat consisted of the faculty splitting into 6 groups, each group tasked with developing one of the above courses. The groups were asked to develop a course description, syllabus and describe how they saw the course fitting into the minor. The courses were then finalized and put into the RMU course catalog. In order to spread the word about the newly established Alternative Energy and Sustainability Minor on campus, flyers and brochures were printed (the brochure can be viewed in Appendix 1 and 2). Along with the distribution of the printed materials, emails were sent out to the faculty and students, and the SEMS faculty were encouraged to announce the minor in their classes.

## **Conclusions**

The development of the RMU Alternative Energy and Sustainability Minor was an experience that involved a great deal of collaboration between the engineering, mathematics and science departments. The minor, which consists of a total of 15 credits, was first offered in the fall semester of 2011 and has had a significant amount of interest among the students. RMU currently has a total of 10 courses that will be offered for the minor and there is a distinct possibility of the minor expanding into a graduate level program in the near future. In an effort to prepare students for the ever-increasing emphasis on the environment in the current workforce, RMU has successfully developed an

Alternative Energy and Sustainability Minor that will give RMU students an advantage in the job market.

## References

1. Bill Schackner, Katie Falloon, "Obama touts economic, energy policies in CMU speech," Pittsburgh Post-Gazette (June 02, 2010)
2. Timothy J. Considine, Robert Watson, Seth Blumsack, "The Economic Impacts of the Pennsylvania Marcellus Shale Natural Gas Play: An Update," (2010)
3. Milken Institute, "2010 Milken Institute Best-Performing Cities Index ranks," <http://www.milkeninstitute.org/>
4. Leadership in Environmental Sustainability, CMU-BCA Executive Development Program 2011," [http://www.bcaa.edu.sg/enews/201101/pdf/CMU\\_draft6.pdf](http://www.bcaa.edu.sg/enews/201101/pdf/CMU_draft6.pdf)
5. "Green Building Rating System," Pittsburgh Today, [http://www.pittsburghtoday.org/view\\_GreenBuilding.html](http://www.pittsburghtoday.org/view_GreenBuilding.html)
6. "Science scorned" Nature 467, 133 (2010)


## Appendix 1: Cover of the Alternative Energy Minor Brochure


**School of Engineering,  
Mathematics and Science**

*For more information, please contact:*


Maria Kalevitch, Dean and Professor of Science, in School of Engineering, Mathematics and Science, at 412-397-2446 or kalevitch@rmu.edu, or Dr. Gavin Buxton, Assistant Professor of Physics at buxton@rmu.edu or Dr. Tony Kerzmann, Assistant Professor of Engineering at Kerzmann@rmu.edu

**The SEMS Alternative Energy and Sustainability minor is open to every major.**






School of Engineering,  
Mathematics and Science  
John Jay  
6001 University Boulevard  
Moon Township, PA  
15108



School of Engineering,  
Mathematics and Science


**SEMS Announces its newest Minor:**

**Alternative Energy and Sustainability**



## Appendix 2: Inside of the Alternative Energy Minor Brochure

**Minor in Alternative Energy and Sustainability**



Robert Morris University Bioreactor

Energy experts have identified major energy sectors that are strategically important for the economy.

**These sectors include:**

Coal	Transmission and Distribution
Oil	Intelligent Building
Natural Gas	Biofuels
Nuclear	Hydropower
Solar	Geothermal Power
Wind	

**Careers in Alternative Energy**


Alternative energy demands continue to rise. According to the Energy Information Industry, in 2008, renewable energy will account for one-third of new electricity added to the U.S. Grid.

The top performing alternative energy sources, include: Wind Energy (according to \*AWEA it used 19,500 MW at mid-year review), Geothermal Energy (according to \*GEA 3,000 MW is already being used, with 4,000 MW under development), and Solar Energy (according to \*SEIA 150 MW panels were installed in 2007, which is 45% more than 2006).

Pittsburgh is one of only three cities that rank in the top 25 regions for employment across the major energy sectors. Pittsburgh is also the only city that resides on top of a nature base of coal, natural gas and shale gas fields.

Pittsburgh and its surrounding regions serve as a hub for the energy industry. Some local corporations and government entities with energy ties, include the following: Consol, Westinghouse, Bettis Atomic Power Lab, Department of Energy-National Energy Technology Labs, Direct Energy, Power Conversion Technologies, Smart Energy, Atlas Energy.

\*AWEA – American Wind Energy Association, \*SEIA – Solar Energy Industries Association, \*GEA – Geothermal Energy Association



**Interdisciplinary Minor in Alternative Energy and Sustainability  
15 credits**

**Core Classes – 9 Credits**

ENVS/ENGR 1022 Energy Fundamentals and Sustainability, 3  
PHYS/ENGR 1023 Alternative Energy Technologies, 3  
ENVS/ENGR 4112 Energy Research Seminar, 3

**Electives – Choice of 6 Credits**

**SEMSTrack**  
ENVS/ENGR 2012 Renewable Resources, 3  
ENVS/ENGR 3022 Energy Storage, Conversion and Transportation, 3  
GEOL/ENGR 4022 Conventional Energy: Fossil Fuels, 3

**SBUS/RMU Track**  
MGMT 3xxx Business Government and Corporate Social Responsibility  
ECON 3060 Environmental Economics, 3  
MGMT 3750 The Sustainable Organization, 3 (Major prerequisites)

- More electives are to be developed by SESS and SCIS

Studies lead to a minor in Alternative Energy and Sustainability.

The program is open to students in any major.

## **Teaching a Sophomore Course with a Laboratory Component Online**

Jumoke Ladeji-Osias, Kehinde Abimbola, Yacob Astatke, Craig Scott  
Morgan State University  
1700 E. Cold Spring Lane,  
Baltimore, MD 21239

Jumoke.Ladeji-Osias@Morgan.Edu, Kehinde.Abimbola@Morgan.Edu  
Yacob.Astatke@Morgan.Edu, Craig.Scott@Morgan.Edu

### **JUMOKE LADEJI-OSIAS**

Jumoke Ladeji-Osias, Ph.D. is an associate professor of electrical engineering at Morgan State University. She teaches courses and conducts research in the area of digital design.

### **KEHINDE ABIMBOLA**

Kehinde Abimbola is a doctoral student in civil engineering at Morgan State University. She has converted several engineering courses from face-to-face to an online format.

### **YACOB ASTATKE**

Yacob Astatke, Ph.D. is an assistant professor of electrical engineering at Morgan State University. He teaches courses and conducts research in communications.

### **CRAIG SCOTT**

Craig Scott, Ph.D. is Professor and Chair of the Department of Electrical and Computer Engineering at Morgan State University. He teaches courses in electromagnetics and conducts research in the area of visualization and engineering education.



# Teaching a Sophomore Course with a Laboratory Component Online

## Abstract

As the student populations at universities evolve, different delivery techniques are being used for courses. Introduction to Digital Logic is traditionally taught in the sophomore or junior year of the electrical engineering curriculum. The conversion from a face-to-face course with a laboratory course to an online course was facilitated by the eight components of The 2008 – 2010 Quality Matters™ Rubric. The course has been delivered for three semesters.

## Introduction

In 2010, the Department of Electrical and Computer Engineering at Morgan State University (MSU) decided to convert some courses to an online format. This was initiated for students who could not attend courses during the day time, when most undergraduate courses are offered, due to work or other obligations. The first courses to be converted were Electric Circuits [1] and Introduction to Digital Logic, a sophomore course that introduces students to the design and analysis of combinational and sequential circuits. The course has both a lecture and laboratory component. This paper will describe the face-to-face (F2F) course, the process of converting to an online course, and the delivery of the course.

## Digital Logic Face-to-Face Course

The digital logic course is a three-credit course that meets for three fifty-minute periods each week. The prerequisite for the course is Electric Circuits and the co-requisite introductory laboratory course. This course enrolls about 80 students each academic year. Most of the class time is spent lecturing the students on several topics including logic gates, Boolean equations, MSIs, flip-flops, memory, VHDL and design. Some of the course periods are held in a computer engineering laboratory. During these sessions, students demonstrate, to the instructor, laboratory exercises that they have built on a prototyping board and tested. These laboratory exercises are completed outside of the classroom, in groups of two or three. These digital circuits allow students to apply the topics covered in the course and are used to reinforce the material in the course.

Course materials are available to students through Blackboard, a course management interface. It is used to hold the PowerPoint lecture slides, handouts for homework, laboratory assignments and to collect documents submitted electronically. It also used to record student's grades and communicate to students. Features such as blogs and discussion are not utilized in the F2F section.

## Converting to an Online Course

The F2F course was converted to an asynchronous online course over a six month period from February to July 2010. It was designed so that students would be able to access course resources at their own time, however, the pace at which material is to be reviewed is established by the course calendar. All assignments and examinations were to be completed by a certain deadline. MSU requires all course builders to attend the Online Course Design Workshop that is offered on campus. This course is delivered online, via Blackboard. The course topics include the online teaching environment, creating modules, the role of discussion, technology integration and

assessment. All courses were required to conform to The 2008 – 2010 Quality Matters™ (QM) Rubric [2]. This rubric outlines many of the practices that are generally accepted for teaching engineering courses and includes some items that are critical for an online student's success [3]. The rubric assigns points to several aspects of an online course to ensure a student's success. These components include the following:

1. Course Overview and Introduction: Ensure that all instructions for students are easy to find including establishing expectations for the course and how to use the modules developed for the course.
2. Learning Objectives: Students are provided measurable learning objectives for each module and information on how to meet the objectives.
3. Assessment and Measurement: The course assessment must be aligned with the course objectives and at a level appropriate for the course. Grading criteria must be explicitly stated.
4. Instructional Materials: Course materials must allow students to meet the course and module objectives.
5. Learner Interaction and Engagement: Interactions that occur between the student and the teacher must foster interaction between course participants and instructors.
6. Course Technology: The tools and media must support student learning and be accessible to students. Students must have access to all tools and instructions must be provided on how to use these resources.
7. Learner Support: Students must be aware of technical, academic and student support services available for the course and at the university.
8. Accessibility: The course should be accessible by all students and provide alternate means of access.

In designing and building the course, one of our goals was to divide the course into modules that last approximately two weeks. These modules were further divided into sub-modules that were topics students could work through in about an hour. The first author then recorded lectures for each sub-module using a lecture capture tool from Panopto (Figure 1). The lecture capture tool allowed the use of video and PowerPoint slides (through desktop sharing). Each lecture was accessible to students via a link in Blackboard. In addition, the laboratory exercises were tested using the Rensselaer IOBoard™ and the Mobile Studio Desktop™ software. This hardware and software combination was selected to allow students complete the laboratory exercises from off-campus locations. A course template was created in Blackboard; it provided the objectives, schedule, links to the recorded lectures, lecture handouts, discussion prompts, homework and laboratory assignments for each module. The course topics were divided into modules as shown:

- Module 0: Course overview, Digital Logic overview
- Module 1: Logic gates, Boolean equations, Boolean algebra, Logic implementation
- Module 2: Karnaugh Maps
- Module 3: Combinational design, VHDL, Multiplexers, Decoders, Timing
- Module 4: Number systems, Binary arithmetic, Arithmetic circuits, VHDL
- Module 5: Latches and flip-flops, Sequential design and analysis
- Module 6: Registers, Counters, Memory, Sequential timing, VHDL

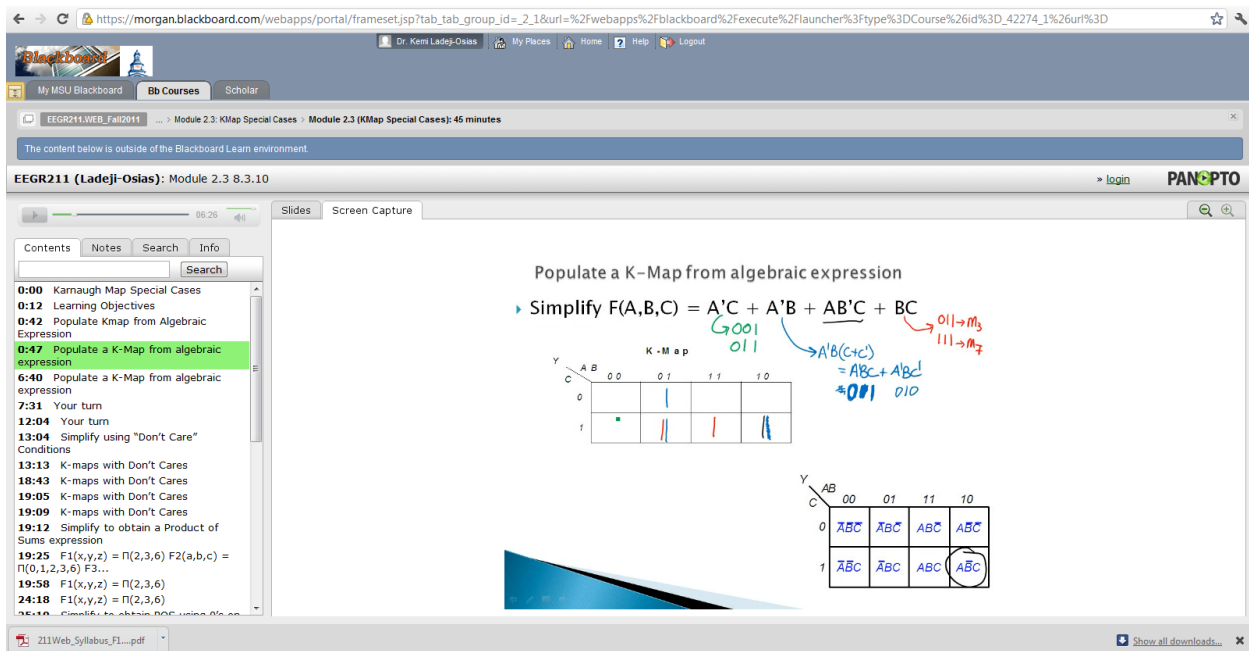


Figure 1: Recorded lecture viewed in Blackboard

Once the course was built in Blackboard, it underwent review at MSU for compliance with the QM rubric. After the course met the criteria, it could be offered to students.

### Delivery of the Course

This first offering of the course was in the Fall 2010 semester and it has been offered every semester since then. In the first semester (Fall 2010), since it was a pilot, students were given the option of taking the course entirely online, or as a hybrid course, with the option of attending any face-to-face lectures. Subsequent offerings have been online only. The enrollment in the online section is usually less than 10. In teaching sophomore students, one observes varying attendance habits and it is important to be able to take attendance in class. Both Blackboard and Panopto provide feedback on the number of times a given website or link is accessed (Figure 2). We were able to track student use of the course modules.

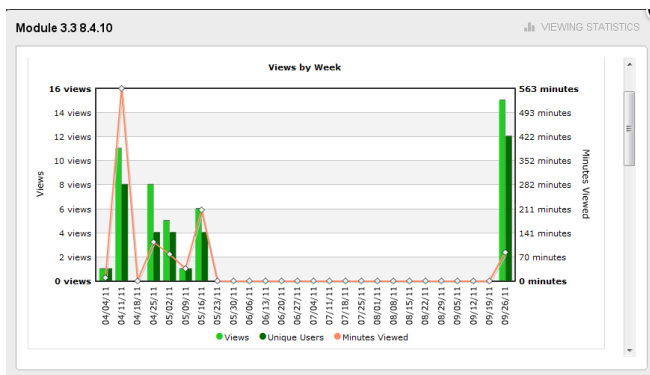


Figure 2a: Lecture access frequency (Panopto)

All User Activity Inside Content Area

Setting Started	Homework	How to Use Modules	Lab Assignments	Module 0	Module 1	Module 2	Module 3	Module 4	Module 5
0	2	0	1	4	6	2	0	0	0
3	11	2	17	11	26	17	9	0	0
0	0	0	0	0	0	1	4	3	0
0	0	0	0	0	0	0	0	0	0
5	22	0	25	19	35	18	20	8	3
0	0	0	0	0	0	0	0	0	0
4	8	1	26	14	37	27	7	1	1

Figure 2b: Course module access frequency (Blackboard)

One aspect of teaching online courses without synchronous delivery is the lack of interaction with students during the lecture. A way to elicit student feedback on the lectures they watched is using the Discussion forum. In fact, interacting with students through weekly discussion prompts is required to pass the Quality Matters assessment. For the digital logic course, we observed that the discussion prompts tended to provide feedback on how students were processing the course topics. Sample discussion questions for Introduction to Digital Logic included the following:

- Based on what you have done so far, what is the relationship between a truth table, a Boolean expression and a logic diagram?
- Boolean algebra is used to simplify with algebraic manipulation while K-Maps use a table. What are the advantages and disadvantages of each technique? Which do you prefer?
- This course is primarily a design course; you learn digital logic techniques and apply them to design problems. Which of the combinational design examples in Module 3.1 did you find most challenging to understand and why?
- We are using the Mobile Studio Boards for demonstration and building circuits at home. Please comment on how often you use the Boards and any recommendations you may have for the laboratory projects.

To allow students to complete the laboratory courses off-campus, students in the online section were provided with hardware and software that allowed them to test their circuits at home and demonstrate the circuits from off-campus locations using video conferencing software (Adobe Connect). The board powered 3.3V CMOS chips and allowed the students to provide a stimulus using a counter and observe the outputs using LEDs or the software interface. Since all students who have taken the course to date have face-to-face courses on campus, all of them continue to use the same laboratory equipment as F2F students when building the circuits on campus.

The typical enrollment of the digital logic course ranges from 15 – 25 students per section, each semester. The enrollment for the online course has been less than ten students. Comparisons of student performance between online and face-to-face students are limited by the low enrollment.

## **Conclusion**

The process of converting the digital logic course to online delivery involved integrating the elements of quality instruction with technology to enhance the learning environment for online students. Course lectures were converted to modules that could be viewed in an hour or less. Students were giving the flexibility of completing and demonstrating laboratory assignments on- or off-campus. Students have gained the flexibility of completing courses outside of day time hours.

## **Bibliography**

1. Y. Astatke, C. J. Scott, J. Ladeji-Osias, “Electric Circuits Online: Towards a Completely Online Electrical Engineering Curriculum”, *American Society for Engineering Education Annual Conference*, 2011.
2. Quality Matters. <http://www.qualitymatters.org>
3. K. Ladeji-Osias, “Planning and Teaching an Undergraduate Course”, *American Society for Engineering Education Annual Conference*, 2005.

## **SECTION 2**

## **Embedding Renewable Energy into the Engineering Technology Curricula**

Radian Belu, PhD  
Scholl of Technology  
Drexel University  
[Radian.Belu@drexel.edu](mailto:Radian.Belu@drexel.edu)

### **RADIAN BELU**

Dr. Radian Belu is Assistant Professor within the Engineering Technology (ET) program - Drexel University, Philadelphia, USA. He holds the second position as Research Assistant Professor at Desert Research Institute – Renewable Energy Center, Reno, Nevada. Before joining the Drexel University Dr. Belu held faculty and research positions at universities and research institutes in Romania, Canada and United States. He also worked for several years in industry as a project manager and senior consultant. He has taught and developed undergraduate and graduate courses in electronics, power systems, control and power electronics, electric machines, instrumentation, radar and remote sensing, numerical methods and data analysis, space and atmosphere physics, and physics. His research interests included power system stability, control and protection, renewable energy system analysis, assessment and design, power electronics and electric machines for wind energy conversion, radar and remote sensing, wave and turbulence simulation, measurement and modeling, numerical modeling, electromagnetic compatibility and engineering education. During his career Dr. Belu published several papers in referred journals and in conference proceedings in his areas of the research interests. He has also been PI or co-PI for various research projects United States and abroad in power systems analysis and protection, load and energy demand forecasting and analysis, renewable energy analysis, assessment and design, turbulence and wave propagation, radar and remote sensing, instrumentation, atmosphere physics, electromagnetic compatibility, and engineering education.

# **Embedding Renewable Energy into the Engineering Technology Curricula**

## **Abstract**

The demand for electrical power is increasing and the conventional energy resources are fast depleting, making the exploitation of renewable energy sources for electricity generation the only alternative. Interest in the production of electricity from renewable energy sources is rapidly increasing. Carbon tax, pollution reduction, and emissions trading legislation are paving the way for environmental accountability and sustainability in the industries. In the last two decades there have been significant advances in the renewable energy technologies, as well as increased demands for engineers and technicians trained in these areas. These require the development of innovative curricula, new courses and laboratories to educate students to work in this rapidly developing industry, or to help professionals become acquainted with these new technologies. However, the pace of change in education curriculum is growing exponentially due to legislative changes, financial or administrative constraints. Engineering education moves into the twenty first century charged with an environmental agenda due to response to wider changes in the society. Educators are regularly modifying curriculum content to embrace technological changes in the learning outcomes. In modern world where everything changes at an extremely fast pace keeping up to date with technology is not only desirable but necessary. The renewable energy is highly interdisciplinary and crosses over between a numbers of research areas, making it quite difficult to be covered in a single course. However, the renewable energy technologies have strong potential for hands-on multi-disciplinary project-based learning. In particular, projects within sustainable engineering and renewable energy technologies can readily involve electrical, mechanical, computer, civil, and chemical engineering aspects while still being accessible to undergraduate students. A natural and efficient way of teaching and embedding renewable energy technologies into curriculum is the problem-oriented and project-based learning approach. In this paper, we are discussing a series of renewable energy projects, included for over a three-year period into the senior project design, power electronics and renewable energy technology courses. The outcomes and observations are discussed in details, as well as the lessons learned and the future improvements. Design, development and build renewable energy projects allow students to work on projects that can be relevant to current leading edge research and technology. The paper also presents the development of an interdisciplinary course on alternative energy as part of this effort to include renewable energy and sustainability into our curriculum. The motivation for the course is outlined and detailed description of the topics covered in the course and the course outcomes are given. The course and the projects are also part of the efforts of to establish a renewable energy concentration at our university.

## **1. Introduction**

Climate change, green house gases, high oil price, limited world oil reserves are driving the increasing search for new alternative and green energy resources. These environmental concerns and the ever-increasing needs for electrical power generation and steady progress in power deregulation have created increased interest in environmentally conscious distributed generation. Of particular interest are alternative energy distributed generation (AEDG) systems such as wind, photovoltaic (PV), and fuel cell (FC) power generation with near zero pollutant emissions. These generation devices can be used in stand-alone configuration or be connected to the electric grid. Given the rapid progress in AEDG development and utilization, there will be a great need for trained professionals with adequate knowledge in this area to be able to plan, design and

operate AEDG systems, evaluate their performance, and evaluate their impact on power systems to which they are connected<sup>2,5</sup>. On the other hand, electric power systems, transmission and distribution systems are undergoing rapid changes due to deregulation, the penetration of dispersed and distributed energy resources (DER), renewable energy generation and power electronics technologies, and the adoption of efficient computation, communications and control mechanisms. Renewable energy is becoming an important and economical source of energy for electricity generation, with a total of 9.33% according to the US Energy Information Administration in its 2003 Annual Energy Review. The bulk of the renewable electric energy comes from hydro, about 7.33%. Emerging renewable energies, such as wind, solar and geothermal account for the remaining 2%. However, it is interesting to mention that wind and solar energy are the fastest growing energy source, with grew more than five-fold in the past decade. Due to the rapid development of the technologies of the renewable energy becomes more and more important. This development and implementation of the technologies for the future energy supply in United States and abroad is also supported by the governments<sup>2,5</sup>.

Engineering and engineering technology programs must offer a relevant and validated curriculum that prepares students for post-graduation success<sup>3,4</sup>. Courses that cover traditional subject matter in mathematics, the sciences, materials, engineering economics and related topics provide the foundation of knowledge upon which specific skill sets are added depending on emphasis. However, it is critical for engineering/technology to transition from theoretical work in the classroom and experiential learning with applications of technology and design. The main objective of senior design courses in engineering and engineering technology curricula is to bridge the gap between theory and real world practice. Accordingly, the proposed senior projects should include elements of both credible analysis and experimental proofing such as design and implementation as discussed in ABET criteria<sup>1</sup>. Additionally, the senior design courses can serve as an excellent culminating experience in the program of study when it focuses on research and design projects that have practical value to consumers or to industrial customers.

Due to this unprecedented growth in the use of renewable energy for electricity generation and in the interest of keeping students abreast of the current scientific and technological developments and trends, we believed that it was important and timely to develop an upper-level undergraduate course on renewable energy. There also is a well-documented demand and need in offering program study, courses and training in the areas of renewable energy and power systems<sup>6-10</sup>. This course focuses on wind energy conversion, solar/PV and fuel cell systems, and the impacts of the intermittency of renewable energy on power systems<sup>10</sup>. We also strongly believe that renewable energy topics must be included when it is appropriate into other courses in our program, especially as projects, an essential aspect of the engineering education.

Therefore the purpose of this paper is to describe topical subjects and projects covered in this renewable energy course, involved in our capstone senior design project. The renewable energy course outline may also be used as a starting point for other instructors considering offering a similar course. This course is primarily focus on the wind and solar energy sources, and to a lesser extent on the other renewable energy sources and related technologies. One the other hand, the senior design project course is a 3-term core course usually taken by the students during their terminal year in the ET program. The lessons learned are presented and the ways to improve project management are discussed. Our senior design project course is a 3-term core course



sequence usually taken by the students during their terminal year. This paper describes the content and motivation of the renewable energy course and the issues related to the inclusion of the renewable energy projects into senior design and power electronics courses. These projects were first offered in the Senior Project Design course sequence during the 2009-2010, and 2010-2011 academic years<sup>10</sup>. The Senior Project Design courses are intended to stimulate the problem-solving capabilities of the students. The topics for the projects are suggested by the author.

## 2. Description of the Renewable Energy Course, Course Syllabus and Content

### 2.1 Course Objectives, Description, and Instructional Design

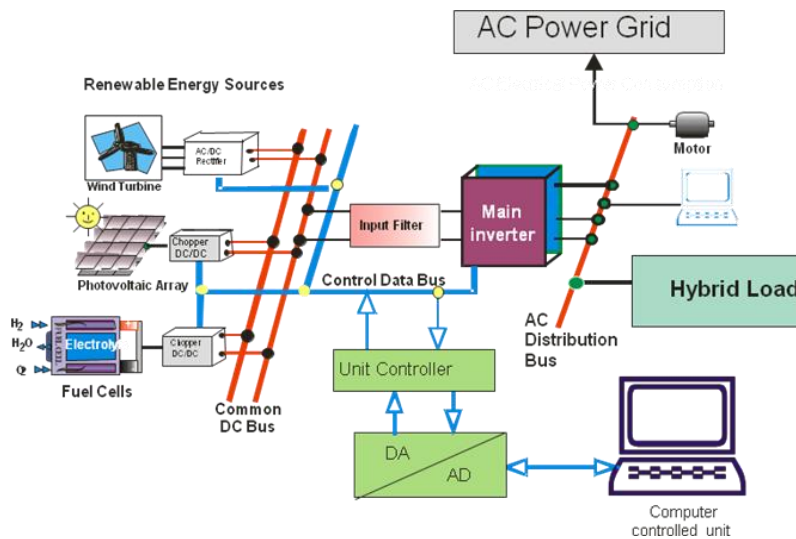


Figure 1 Block diagram of hybrid power (wind/PV/fuel cell) system [adapted from Reference 7]

The course will provide an introduction to the renewable/alternative energy systems with an emphasis on those utilizing solar and wind technologies, storage energy systems and to a lesser extent to the other renewable energy systems, as wave energy, geothermal, etc. The students will learn how the technologies work to provide electrical power today and will get a glimpse of the capabilities foreseen for the future and a few of the basic research needs. The course provides an introduction to energy systems and renewable energy resources, with a scientific examination of the energy field and an emphasis on alternate energy sources and their technology and the most common applications. This course covers the principles of energy conversion in the three distinct areas of wind, solar/PV, and fuel cell power generation, system planning and design<sup>6-10,19</sup>. It also covers the modeling, analysis of major components of an AEDG system shown in Figure 1. The topics covered also include the need and the benefits of AEDG, energy storage devices, control and power electronic interfacing. The benefit of such broad coverage is to give the students a broad view of the various components of AEDG. Each student picks one area to explore further by studying and presenting one or two research paper(s) to the class as well as doing a project developing a written report and presenting the results of their work to the entire class.

Due to the time constraints, our university is a quarter-based institution course materials are divided in ten modules. Each module is self-contained and is covering the basic and essential knowledge of the topics. The modules are divided into three parts: *basic principles, system*

*technology, and experimental aspects of the topics.* The imparted knowledge is divided into two parts: the first part is the basic knowledge, and the second part is the deepened knowledge, additional contents of teaching, and references. Modules are ended with a multiple-choice quiz, covering theoretical aspects of the topic. After completing the quiz students get access, through the course management system to download the unit homework. The instructional design illustrates how to better present the concepts, convey the objectives of the course in a pedagogical way and appropriate it to suit the targeted audience. Interactive tutorials support both instructor lead and self-paced learning. This course is designed to introduce the students to the principles, characteristics, power conditioning aspects of major renewable energy technologies. The students will also explore the use of electrical equipment required for power transmission and conditioning, and understand their workings and principles. It provides students with knowledge so they are able to design, analyze, and implement small-scale standalone and grid connected renewable or hybrid energy systems. During the second part of the quarter the students are required to design, via a project a hybrid power systems, integrating wind, PV and energy storage systems to provide power for a specific load. The project is handled by a team of 3 to 4 students. The project is part of the final grade of the students, and is complementary to the final exam. The students are free to make the team based on their preferences and mutual interests. They are required to make a 10-min presentation on the project topic during the final exam week of the quarter. The outline of the course includes (ten 3-hour lectures/units):

1. Basic principles of energy generation
2. Introduction to renewable energy systems
3. Electric machines Basics; Electric machines for renewable
4. Solar energy fundamentals
5. Photovoltaic energy production; Photovoltaic systems
6. Wind energy resource characteristics
7. Wind energy conversion systems: aerodynamic and electric aspects
8. Wind energy modeling aspects
9. Fuel cell systems
10. Distributed generation and power quality

This course supports the achievement of the following outcomes: a) an appropriate mastery of the knowledge, techniques, skills and modern tools of their disciplines; and b) an ability to apply current knowledge and adapt to emerging applications of mathematics, science, engineering and technology. Our upper-level undergraduate course on renewable energy and power systems was first offered in spring 2009 quarter. It is a three credit-hour course. The course primarily focuses on wind energy, solar/PV, and fuel cell generation, and to a lesser extent on other renewable energy sources and related technologies. Wind and solar energy make up about 75% of the course since wind and solar energy represent the fastest growing areas of renewable energy in the past decades. The teaching modules of this course consist of the following topics each of them presenting a special type of renewable energy and dispersed generations.

Since this course deals mainly with the analysis and the components of the wind and solar energy conversion systems, as well as the analysis of integration and interconnection to the power system grid, the desired prerequisites include a course in energy conversion, electric machines and co-requisites a course in power electronics and power system analysis. Students are expected

to be well around in general renewable energy issues and energy conversion technologies. They are expected to be particularly skilful in analyzing and solving wind and solar power systems and related problems. Exam combined with a presentation represents the significant part of the student grade and is used to assess the student course understanding. The renewable energy course is divided into ten modules. Each module can be completed within three to five 50-minute lecture sessions. Due to the diverse and intrinsic interdisciplinary subjects needed to be covered, the following reference texts are used and recommended to the students<sup>11-14</sup>.

On completion of this course students should be able to explain: various types of non-renewable technologies, various types of renewable energy technologies, the environmental problems associated with non-renewable and renewable sources of energy, and how to consider the environment with regards to production, conversion and use of energy, how solar cells work and how they are manufactured, the most common applications of solar energy, the future of renewable sources of energy, Students should also be able to describe: the design and operation of a small hybrid system, an integrated renewable energy and energy storage system for remote areas, the concept of energy efficiency and energy conservation, the structure, operation and design of PV, WECS and hybrid power systems, the structure, operation and design of a PV or WECS system, the environmental impacts associated with the energy production, the use and disposal of PV modules or a component of a wind energy conversion system.

## **2.2 Activities for Hands-on Laboratory Experience**

It is well known that good laboratory experiences increase the interest of students in an area by connecting the theory to practice facilitating an active learning process<sup>18-22</sup>. An interesting strategy have been developing at school of technology of our university to have a well trained engineering force with a focus on renewable energy and its related aspects, specifically by involving the design, controls and power electronics of such systems. The main objective of this strategy is essentially to prepare the best engineering technology workforce to satisfy the required energy needs of a country or a region without sacrifice its future sustainability. The presented laboratory experiences have a potential to reach over 50 students a year in Power Electronics, and Renewable Energy Technology basic undergraduate course, 20 undergraduate students in advance courses in addition to those doing undergraduate research. This experience have a tremendous impact in the large amount of ET students that graduate every year from concentrations related to electrical engineering technology (EET) and the future planned renewable energy concentration. The laboratory exercises include:

1. Solar cells and panels, PV systems – MATALB simulation and experimental test
2. Control of single-phase grid converter used for PV residential applications
3. Control of three-phase grid converter used for Wind Energy Conversion Systems
4. Battery tests.

## **3. Power Electronics and Senior Design Project Courses: Increased Renewable Energy Content**

A natural and efficient way of teaching core engineering courses is the problem-oriented and project-based learning approach. Students are often unaccustomed to assimilating material from many courses at one time, thereby making it difficult for them to simultaneously bring together

the circuit, signal and system analysis, electro magnetics and control which are required to fully describe the operation of a power electronic converter. In problem- and project-based learning (PBL), learning is encouraged by a problem and students learn topics when they need them during problem solving. In Project-Based learning, students also manage resources and time for project execution and work in teams<sup>18,20-22</sup>. Both Problem- and Project-Based Learning have been applied in many fields of engineering. Motivated by the PBL teaching and learning approaches, for the last three years our focus shifted towards incorporating renewable energy concepts in our senior design project and power electronics courses in order to make them more attractive to the students. To enhance the hands-on experience this course was restructured as a project based course. Students are required to analyze, design, simulate or built a completely functional system, as an end-of-term project, selected from a list proposed by the instructor. The goal of the design project is to explore and enhance students understanding of the fundamental power conversion principles, power circuit simulation capability and hands-on demonstration of circuit prototyping. The course project is worth 20% of the course grade. Students are required to present their project output in a poster session arranged for a technical audience. They are also required to summarize the results of the design in a short report by the end of the course.

Power electronics is the enabling technology for the efficient generation, transmission, distribution and management of electrical energy<sup>15-18</sup>. Teaching power electronics is a challenging task since the field is quite broad and requires significant knowledge in multiple areas of electrical and computer engineering. The job of a course provider is often made more difficult due to the theoretical analysis of topics, such as magnetic characteristics, analog electronics, and compensator design, are particularly hard to comprehend without experimental observations. Thus, an effective power electronics course should ideally contain hands-on design and experimental work, as well as projects in addition to the study of theory and simulations [2-9]. Motivated by these facts in the 2008-2009 academic year, we started to propose a few mini projects related to the renewable energy. While beginning with the 2009-2010 academic the author also proposed several senior design projects focusing on wind and solar/PV systems. From this perspective, these approaches of restructuring the power electronics course and adding renewable energy projects to the senior project design courses are of critical importance in solidifying the fundamentals of power electronics and renewable energy into the curriculum and creating the foundation for the planned renewable energy concentration.

### **3.1 Capstone Project Design Course Sequence**

MET 421/422/423 (Senior Project Design) is a sequence of three-quarter capstone project design courses required for all the BSET majors. The course focuses on planning, development, and implementation of an engineering design project, which includes formal report writing, project documentation, group presentations, and project demonstrations. The goal of these courses is to demonstrate the ability to manage a major project involving the design and implementation of products with a mixture of electrical and mechanical elements as a member of a product development team. In these project-based courses, the students are expected to effectively manage their time and team efforts to produce a finished product in three ten-week quarters. No textbook is required. Progress and formal reports, and oral presentations constitute integral components of this course sequence. Before beginning the projects, student teams are provided

adequate training in project formulation and resource analysis, performance goals and team expectations, public presentations of project work, and individual project supervision<sup>19</sup>.

ABET defines Engineering Design as: “The process of devising a system, component, or process to meet the desired needs<sup>1</sup>. It is a decision making process, in which the basic sciences, mathematics, and engineering sciences are applied to convert resources optimally to meet stated objective<sup>1</sup>. Among the fundamental elements of the design process are: the establishment of the objectives and criteria, synthesis, analysis, construction, testing and evaluation”<sup>1</sup>. In our senior design classes we have placed this definition at the core of our courses. First we focus on objectives and ask the student to write a short proposal stating these objectives, principles, and the decisive factors to reach the stated goals. These projects involved elements of structural design, wind and solar energy resource assessment, electrical, electronics and computer engineering system design. The second step is conceptualization and laying down how to achieve the stated objectives<sup>18,19</sup>. At this junction the students are encouraged to draw a block diagram showing different components of the system they want to design. A set of questions are posed to students to further understand the task at hand. These are typical questions:

- What are the inputs to the system and, what are their characteristics and magnitudes?
- Do the inputs require conditioning?
- What is the medium through which inputs are interfaced to the system under consideration?
- Do the inputs dictate to the system to be designed how to behave, or just activates the system?
- What is the voltage, current and power requirements for the load?
- Is it a single output or multi-output system?
- Are there feedback loops in the system?
- Do the loads require separate power supplies?

Once the students compile the answers to these questions, they are directed to perform system analysis, design, component purchase and fabrication, building and testing of the prototype, as well as the overall design improvements.

### **3.2 MET421/422/423 Courses Structure and Organization**

From the very beginning, this course sequence was organized following the ABET guideline for capstone and/or senior project design courses. The senior design class is organized in a very structured form.

**Teams:** All students have to work in teams of three or four. We consider this to be the optimum team size. A team of two may result in distress in cases where one of the students was not able to do his or her share of the work, while for teams larger than four may have difficulties to choose projects which were challenging enough for such a big group of students and still could be finished within three-quarter time frame.

**Self and Peer Review:** A very simple self and peer review system has been introduced. The students must evaluate their own and their team members' performance on a scale of 5. The main

challenges we faced were that we never had anything similar to this and were inexperienced in how to adequately give feedback to the students.

**Industrial Advisors:** Some of the department's advisory board members are also serving as industry advisors for the senior design class. They are reviewing reports, listen to presentations and give feedback on those and are also serving as judges for the Senior Design presentations.

**Reports:** All teams must hand in a proposal, two midterm design reviews, and final report. Various faculty and industry advisors review all these reports and the students are provided feedback on their projects as well as on their report writing.

**Presentations:** All teams must present their proposals and first quarter design review. On the Friday before Final Exam week, in the Spring quarter all teams show their prototypes. The audience for these presentations is the class, faculty members and some of the industry advisors. They also prepare a professional poster to display with their projects. Some of the faculty and industry members also serve as judges. The teams are judged on the projects' technical content. The individual students are judged on their presentation style. These ratings have a two-fold purpose: they will be used as a part of the students' final grades and for a ranking of projects and teams. The winning team receives an award and members' names will be engraved on a plaque.

### **3.3 Increased Renewable Energy Content of the Senior Project Design**

For the last two years, our focus shifted towards incorporating renewable energy topics in our senior project design courses<sup>9,18,19</sup>. In the first quarter in the project design course sequence we assigned to our students the project topics related to renewable energy, power systems or other engineering topics. These projects are a good example of multi-disciplinary cooperation of different engineering disciplines as well as providing valuable hands-on experience to the students. In addition to providing useful lessons in teamwork and project management, the project will provide a working demonstration of a wind and solar energy system<sup>18,19</sup>. For the last two years our focus shifted towards incorporating renewable energy concepts in our senior design courses. Two examples of senior projects are presented in the following subsections of this paper. During the first month of the fall quarter section of the course, each team is given partial specifications for the project. Each team demonstrates the finished project to the entire class and then a written report summarizing the project is handed in as part of the senior project design course. This process synthesizes all of the basic materials in the core courses and can also be used as part of the requirements of the senior project requirements for each student. Examples of the renewable energy senior design projects included in this course are:

1. Power Conditioning Units for PV-Powered Water Pumping
2. Control and Power Electronics of a Small Wind Power for Battery Charging
3. Fuel Cell Based Domestic Power Supply
4. Savonius Micro-Wind Turbine for Remote Applications
5. Modeling and Simulation of a High Performance Wind-Electric Battery Charger System
6. High Efficiency Charger for Photovoltaic Power Systems
7. Indoor Solar Harvesting Energy for Sensor Network

The design also includes test models of the prototypes, which can be tested and operated. The next sections will discuss two of the project listed above.

### 3.4 Power Electronics Course Design Projects

To enhance the hands-on experience this course was restructured as a project based course. Students are required to analyze, design, simulate or built a completely functional system, as an end-of-term project, selected from a list proposed by the instructor. The goal of the design project is to explore and enhance students understanding of the fundamental power conversion principles, power circuit simulation capability and hands-on demonstration of circuit prototyping. The course project is worth 15% of the course grade. Students are required to present their project output in a poster session arranged for a technical audience. They are also required to summarize the results of the design in a short report by the end of the course. During the second week of the quarter, each student team (three to four individuals) is given partial specifications for a renewable energy conversion power electronics application. The team builds it initially with the function module and/or using circuit simulation packages. Each team demonstrates the finished project to the entire class. A short written report summarizing the project is also required as part of the design project. This process synthesizes all of the basic material in the power electronics course and can also be used as part of the requirements of the senior project requirements for each student. Examples of end of term design projects included in this course are:

1. Analysis and Design of Single-Phase PV Inverters
2. PV Maximum-Power-Point-Tracking Controller
3. Line-Commutated Inverter
4. Design a Soft-Starter for an WT Induction Generator
5. Parallel Inverter System for Large Load
6. Fuel Cell Inverter Based

### 4. Student Assessment

Table 1 Questionnaire for the evaluation of the Project-based Power Electronics course

Q1	Are the courses challenging and interesting?
Q2	Have you learnt more than what you expected with the course?
Q3	Is the team project useful to you?
Q5	What was the level of “hands-on” feeling experienced the laboratory exercises?
Q6	Please, provide an overall evaluation of the course

The Power Electronics and Senior Project Design courses, using the new teaching and learning approach was first time offered in the Fall 2008 quarter, and 2009-2010 academic year respectively at the main campus of our university. It was offered in Winter 2009 quarter at one of the partner college. At the end of each quarter, all students have been requested to answer (with a five point scale: 1-very poor, 2-poor, 3-satisfactory, 4-good and 5-very good) an anonymous questionnaire as shown in Table 1. According to the results, the new project-based approach of power electronics and the received a 3.9/5.0 rating, comparing with an average rating of 3.4/5.0 for the all courses at our program. The results from the students’ feedback have been extremely

positive with the regard to the renewable energy-related projects and the experiments provided during the laboratory sessions. The majority of students felt that such projects enhanced their understanding of the theoretical materials and made the course more interesting.

## 5. Conclusions and Future Work

The design experience develops the students' lifelong learning skills, self-evaluations, self-discovery, and peer instruction in the design's creation, critique, and justification. Students learn to understand the manufacturer data sheets, application notes, and technical manuals and component specifications. The experience of teamwork, prototype design and test, which would be difficult to complete individually, gives the students a sense of satisfaction and accomplishment that is often lacking in many engineering courses, not including projects. Furthermore, the design experience motivates student learning and develops skills required in industry. The students were able to make satisfactory estimations and calculations of these projects. Their results reflect that they have understood well all the basic ingredients of the modeling techniques and design of the renewable energy systems. They were also very pleased with the approach used to teach them. Our experience with the incorporation of renewable energy topics in the senior project design courses demonstrated that the abstract knowledge acquired by the students during their first three years of studies was put into practice. The students in these projects gained extensive knowledge of electronics and mechanical components and their characteristics, environmental and structural constraints, separating different aspects of the project, such as generator or converter type, its parameters and characteristics, and what are the final outputs and its relationship to the load, etc. They learned, during the three-quarter senior design project course sequence with increased renewable energy to identify a problem, conduct research on a particular project, and compare their finding with other similar projects.

The key element to the success was the interdisciplinary team work and the efforts of the faculty to continually instruct the students on the completion of their projects. The lessons learned from this type of projects lead us to believe that they are very attractive and favorable for students. Finally, they may represent one of the ways to enhance engineering education in our college.

## References

1. Engineering Accreditation Commission, "Criteria for Accrediting Engineering Programs," <http://www.abet.org/criteria.html>. (2002).
2. G.T. Heydt and V. Vittal, "Feeding Our Profession," *IEEE Power & Energy Mag.*, Vol. 1(1), Jan./Feb. 2003.
3. Petty, I.: Vision 2020 - Education in the next Millennium. In: Hagström, A. (Ed.), *Engineering Education: Rediscovering the Centre* (Proc. SEFI Annual Conf., Winterthur and Zürich, 1999) pp. 27-35.
4. R.S. Friedman, F.P. Deek, *Innovation and education in the digital age: reconciling the roles of pedagogy, technology, and the business of learning.*, *IEEE Transactions on Engineering Management*, Vol. 50, No. 4, Nov. 2003, pp. 403-412.
5. A. Brobely and J. F. Kreider (editors), *Distributed Generation the Power Paradigm of the New Millennium*, CRC Press, 2001.
6. S. Santoso and W.M. Grady, *Developing an Upper-Level Undergraduate Course on Renewable Energy and Power Systems*, *Proceedings*, 2005 IEEE PES General Meeting, San Francisco, CA, June 12-16, 2005.



7. M. H. Nehrir, *A course on alternative energy wind/PV/fuel cell power generation*, IEEE Power Engineering Society Meeting, June 18-22, 2006, Montreal, Canada
8. R.G. Belu and A.C. Belu – *Development a Web-based Course in Renewable Energy Sources*, 2006 Annual ASEE Conference, Chicago, July 2006 CD Proceedings)
9. R.G. Belu and A.C. Belu – *A DecisionSupport Software Application for Design of Hybrid Solar-Wind Power Systems- as Teaching-Aid*, 2007 Annual ASEE Conference, and Exposition, Honolulu, Hawaii (CD Proceedings).
10. R.G. Belu and I. Husanu - *An Undergraduate Course on Renewable Energy Conversion Systems for Engineering Technology Students*, 2011 ASEEE Conference & Exposition, June 26 - 29, Vancouver, BC, Canada (CD Proceedings).
11. Gilbert M. Masters , *Renewable and Efficient Electric Power Systems*, Wiley Interscience, 2004
12. M.K. Patel, *Wind and Solar Power Systems*, CRC Press, 1999.
13. J.F. Manwell, J.G. McGowan, and A.L. Rogers, *WindEnergy Explained*, Wiley 2003.
14. R. Messenger and J. Ventre, *Photovoltaic SystemEngineering*, second edition, CRC Press, 2003.
15. Ned Mohan et al, *Teaching Utility Applications ofPower Electronics in a First Course on Power Systems, IEEE Transactions on Power Systems*, Vol. 19, No. 1, Feb. 2004.
16. H. Salehfar, *State of the Art Power Electronics, Electric Drives, and Renewable Energy Systems Laboratories at the University of North Dakota, Proceedings*, 2005 IEEE PES General Meeting, San Francisco, CA, June 12-16.
17. N. Mohan, T. M. Undeland and W. P. Robbins, *PowerElectronics – Converters, Applications, and Design*, John Wiley & Sons , Inc., 2003.
18. R. G. Belu, *A Project-based Power Electronics Course with an Increased Content of Renewable Energy Applications*, June 14-17, 2009 Annual ASEE Conference and Exposition, Austin, Texas, 2009 (CD Proceedings).
19. R.G. Belu - *Renewable Energy Based Capstone Senior Design Projects for an Undergraduate Engineering Technology Curriculum*, 2011 ASEEE Conference & Exposition, June 26 - 29, Vancouver, BC, Canada (CD Proceedings).
20. L.R.J.Costa,etal.,*ApplyingtheProblem-BasedLearningApproach toTeachElementaryCircuitAnalysis*,IEEE Transactionson Educ.,vol.50, pp. 41-48, 2007.
21. A.A.Mota,etal., *Teachingpowerengineeringbasicsusingadvanced web technologiesand problem-based learning environment*,IEEE Transactionson Power Sys., vol.19, pp. 96-103,2004.
22. J.Macias-Guarasa,etal.,*Aproject-basedlearningapproachtodesign electronicsystemscurricula*IEEETransactionson Education,vol.49, pp.389-397, 2006

## **Teaching Software Engineering and Computer Science Online Using Recent Instructional Technology**

PATRICK BOBBIE

PATRICK BOBBIE is currently professor in the Department of Computer Science and Software Engineering at Southern Polytechnic State University (SPSU) in Marietta, Georgia. He has a Ph.D. in Computer Science from the University of Louisiana, Lafayette. Email him at: [pobbie@spsu.edu](mailto:pobbie@spsu.edu).

SHERYL DUGGINS

SHERYL DUGGINS is currently professor and graduate coordinator for the MSSWE program in the Department of Computer Science and Software Engineering at Southern Polytechnic State University (SPSU) in Marietta, Georgia. She has a Ph.D. in Computer Science from the University of Florida and an M.S. degree in computer science from the University of Missouri, Columbia. Email her at: [sduggins@spsu.edu](mailto:sduggins@spsu.edu).

VENU DASIGI

VENU DASIGI is currently professor and department chair of Computer Science and Software Engineering at Southern Polytechnic State University (SPSU) in Marietta, Georgia. He has Ph.D. and M.S. degrees in computer science from the University of Maryland, College Park. He has taught for about 25 years in higher education, which includes developing and teaching online courses in data structures and mathematical structures for computer science at SPSU. Dasigi is a Commissioner with the Computing Accreditation Commission of ABET, Inc.

# Teaching Software Engineering and Computer Science Online Using Recent Instructional Technology

**Abstract** – Higher education is fast becoming a very competitive market with the plethora of universities offering online degrees increasing across the country. Our university has been offering distance education in various forms since the 90s. But the courses we could offer using distance technology of the 90s were limited due to the nature of our content – computer science and software engineering courses typically have technology requirements that could not be supported at that time. Now with high-speed internet connections and new technologies, we are no longer restricted by our content. Besides the availability of new technologies, there may also be pedagogical reasons to consider adding online components into student learning, according to some studies.

This paper will address learning content management systems and classroom tools used to facilitate online courses. Specifically, we will discuss the various tools and techniques we have used and incorporated in the development and delivery/teaching of courses in the School of Computing and Software Engineering. For development SmoothDraw™, Camtasia™, Tablet PCs, and Blackboard/Vista™, will be examined. We'll explore the use of Echo360™, wall-mounted cameras, Wimba, SmartBoard™ and tablet PCs for delivery. For content management we'll explore Blackboard's Vista™ and Sakai-Globule.

*Keywords:* Distance learning, Online learning, e-Learning, Learning Content Management Systems, and Course Management Systems.

## Introduction

Higher education is fast becoming a very competitive market with the plethora of universities offering online degrees increasing across the country and around the world. Studies indicated that as early as 2001, at least 3 million US students were enrolled in online education [15], and there were 90 million students worldwide studying online at 986 institutions in 107 countries [5]. Today, the e-learning market has a growth rate of 35.6%, which makes online education a very competitive business [20]. In 2001, venture capitalists invested one billion dollars in education companies and “entrepreneurs are swarming to the marketplace” [11]. Sun et. al [18] have even suggested that e-learning is emerging as the new paradigm of modern education.

While some of the popularity of online learning is driven by the demand for increased convenience and access for students, there are important studies pointing to the enhanced pedagogical value of online education. A recent report from the U.S. Department of Education suggests that learning outcomes can be better achieved in certain groups of older learners in the online mode than the traditional face-to-face (F2F) mode of learning [14]. The results are even better for those taking the course in the hybrid mode. However, the study cautions against attributing the improvement to the online medium per se. One way to look at the results is that the conventional F2F mode is missing something that the online mode provides, e.g., extra time for independent reflection, which is perhaps particularly effective for older learners. The study also points out that the results may be more relevant to higher education than to the K-12

context.

The emergence of the Internet and advances made in information and communication technology as well as the technological advances made in multimedia, personal computers and networking has driven the development of distance learning in the *information age* [19, 12]. The need for “anytime, anywhere” learning has led to the development of e-learning, otherwise known as web-based or online learning, which uses “telecommunication technology to deliver information for education and training...The great advantages of e-Learning include liberating interactions between learners and instructors, or learners and learners, from limitation of time and space through the asynchronous and synchronous learning network model” [12, pps.1183-1184]. Maddux et.al. [13] suggested that higher education is on the cusp of a revolution due to several recent changes in technology including:

- 1 “Recent rapid growth of broadband Internet connections in private homes...
- 2 Recent widespread availability of free or inexpensive programs that make use of voice over Internet protocol and video over Internet protocol...
- 3 Transition of the World Wide Web from a space where users search for and read information to an environment for collaboration...
- 4 Much wider and currently rapidly increasing availability of high quality educational websites.”

This paper will give an overview of the state of distance education today, and will take a look at what’s being used at our university. We will address *learning content management systems* and classroom tools used to facilitate online courses. For content management we’ll explore *Blackboard’s Vista™* and *Sakai-Globule*. For development *SmoothDraw™*, *Camtasia™*, tablet PCs, and *Blackboard/Vista™*, will be examined. We’ll explore the use of *Echo360™*, wall-mounted cameras, *Wimba™*, *SmartBoard™* and tablet PCs for delivery.

### **Distance Education at [Our University]**

[Our University] has been offering distance education in various forms since the mid-1990s. The technology we used at that time consisted of telecourses and videotapes. To facilitate the recording and synchronous delivery at that time required extensive technological support. A special classroom was built on campus that was equipped with cameras, microphones suspended from the ceiling, television screens capturing the students at the remote locations, and a special tech room off to the side of the classroom filled with recording and transmitting devices and manned with a technician running the equipment. The remote sites were equipped similarly, so that in effect, all locations were both sending and receiving audio and video feeds. But there were limits to what we could do at that time. Specifically, the courses we could offer using 1990s technology were limited due to the nature of our content – computer science and software engineering courses typically have technology requirements that could not be supported at that time. Our face-to-face students were able to access the required software via our Computing and Software Engineering (CSE) labs, but offering these tools to our distance students was impossible as we were limited by the 1990s technology.

### **Learning Content Management Systems**

One of the biggest changes in distance education was the development of Course Management Systems (CMS). In 1999, the University System of Georgia (USG) adopted WebCT as the standard USG online course delivery format [8]. WebCT is a Course Management System that provides a number of features including calendars, threaded discussions, assignment tools, tools for creating and viewing grades, email services within the tool, file management tools for uploading and downloading files, whiteboards, online chat, and a number of other tools. Together these tools provide a complete learning environment for distance classes. The USG replaced WebCT with Blackboard/Vista, which is the CMS the USG is currently using. However, as technology advances at a rapid pace, we will be moving to Desire2Learn [6] within the next two years. "To meet the needs of the students and faculty of the University System of Georgia in the 21<sup>st</sup> century, the USG LMS transition task force strongly recommends adoption of the Desire2Learn platform as the next generation USG Learning Management System. This platform outranked all of the competitors in all areas of consideration other than the ease of transition. The lead in that category was Blackboard Learn 9, which is not a surprise given that the system will be moving from a Blackboard product currently in use. However, Desire2Learn was a fairly close second place contender in this area [19]."

In the early use of these CMS, the virtual classroom was eerily similar to a traditional face-to-face classroom in which the professor "lectured" in the front of the classroom to the passive students who sat quietly at their desks. Online classes at this time consisted of "lectures" that the students *read* that were posted in the CMS, as opposed to traditional F2F classrooms in which the students *hear* the lecture as it's happening live, at a time when all the students and the professor were gathered physically in the same location. In a F2F classroom discussions occurred in that same physical classroom, and all students could ask questions and hear all responses. In the CMS classroom discussions, the students participated asynchronously, whenever and wherever they were when they logged into the CMS. The other students could "hear" (via reading) their classmates' discussion points and contribute to the threaded discussion or ask a question or make a comment by starting a new thread in the discussion topic. It was a nice simulation of or alternative to a traditional classroom. Unfortunately, not all students succeed in this type of learning environment, and a number of online students stop their online learning after their initial experience [18]. Research has shown that online students who take courses of this type, in which the communication is delayed, asynchronous, and without a personal, human feeling to them feel isolated and dissatisfied with the learning environment [1, 4].

The two most frequently used Course Management Systems in 2006, WebCT and Blackboard, which were used by 48.8% and 41.9% respectively of Blakelock's [2] 37 survey respondents, have since merged when Blackboard purchased WebCT in 2006. As of today, the term Course Management Systems is still being used, but more frequently these types of systems are now called either Learning Management Systems (LMS) or Learning Content Management Systems (LCMS). Today, instead of just two products dominating the market, there are now many competing products available, including open source, however Blackboard is still the leading educational course management system [11].

In addition to using Vista™ at [Our University], some professors are also experimenting with Sakai-Globule, which is open-source, and is gaining popularity and is being used by institutions like Georgia Institute of Technology. Sakai, free software, provides capabilities

for storing and managing course data, student profile and assessment data like exams, projects, etc., and revising of such data. Globule is integrative with Sakai by offering a server-based environment for developing content for eventual 'pushing' to Sakai servers wherever they may be sited in a network of campuses or locations.

**Sakai** is a collaborative learning tool which has been deployed by hundreds of institutions and thousands of instructors, and millions of students have benefitted from it. One of the strengths of Sakai is the ability to incorporate and deliver real-world simulations in lectures to stimulate student interest and learning. The desire to develop a rich and strong course management system (CMS) for content sharing and engaging students prompted IBM and Sakai Foundation to sponsor the *Teaching with Sakai Innovation Award Program (TSAIP)*. TSAIP is aimed at identifying and recognizing users of Sakai in inventive and exemplary ways [17].

While Sakai provides a rich environment for inventive learning and sharing, **Globule™** is a server-based tool for developing and replicating content materials [10]. Thus, web-based documents can be developed offline using Globule to suit the pedagogical approaches of instructors, while allowing the design and development of lecture materials using different but integrative metaphors and multimedia content such as graphics, simulations, animations, text, power-point slides, video, and audio.

## Development Tools

SmoothDraw™, Camtasia™, Tablet PCs, and Blackboard/Vista™ have been used for development. SmoothDraw is a graphics drawing tool, like the Paint™ component of Microsoft Office suite. SmoothDraw supports an array of digital-pens of different font sizes and types, which can be selected through the stylus of any Tablet PC for drawing, sketching, writing, or highlighting information or facts during course presentations. Further, SmoothDraw can be integrated with Camtasia, a screen capturing tool, which is rich with features for screen and video recording, editing, producing, publishing and saving of contents into a variety of formats including WMV (Windows Media Video), AVI (Audio-Video Interleave), M4V (for Podcasting, iPhones, and iTunes), MP3 for audio only or MP4 for audio-video, GIF for animation, and MOV for Quicktime™ movies. The saved lecture can be reduced in size for portability and fitness in small handheld devices or played back from dedicated servers using content management tools. Vista™ also supports an integrated set of tools for preparing, editing, importing, and organizing content data, files, images, and presentation files using its 'linking-based' feature for eventual delivery in Wimba™.

**SmoothDraw™** is an environment like Microsoft Paint™ IDE for natural painting and digital free-hand drawing. As a software tool it can be used to produce high quality sketches, writing, diagramming/drawing, and developing illustrative content. SmoothDraw works with tablets and Table PC hardware so when used with audio-video interfaces such as WebCam and microphones/headsets, the user can develop rich, multimedia content for later (or real-time) processing and integration into CMS platforms. SmoothDraw supports such brushes as pens, pencils, and dry media; retouch tools; layers; and image adjustment. The array of digital-pens of different colors, font sizes and types can be selected through

the stylus of any tablet or Tablet PC for drawing, sketching, writing, or highlighting significant sections of contents during development [18].

**Camtasia™** is multimedia software that provides capabilities to record on-screen movements of such metaphors as mouse and displayed multimedia content that appears on the screen. Camtasia allows the recording of a demarcated area of the screen which an instructor is interested in or where on-screen movements are confined to. The recorded content can then be further developed into videos using the rich set of tools for audio level selection; pause-restart features for recording; editing tools for clipping undesirable tracks of the recording and insertion of pre-recorded components, for example, pre-recorded introductory remarks, concluding summaries of lectures/presentations, or audio-clips used as jingles; resizing of captured content; customizable production settings of contents into WMV (Windows Media Video) and other formats like Flash, .avi, .mov, .m4v (for iPod, iPhone, iTunes videos), .mp3, and .gif (for animation). After the contents have been run through the production feature of Camtasia, the saved videos can be reduced in size for portability and fitness in small handheld devices or played back from dedicated servers using content management tools. This capability not only enhances learning, but also offers students distance learning options in anytime-anywhere modes, including wireless with mobility [3].

### **Tools for Delivery**

Echo360™, wall-mounted cameras, Wimba, and SmartBoard™ have all been used for delivery at [Our University]. Tablets can replace SmartBoard™ to support delivery from private settings and have been part of the plan of universities such as ours to respond to pandemic situations. Echo360 is a server-based system which works with mounted cameras to capture live presentations. The immersion of SmartBoard illustrations and amplification of presentations offers students rich, video content for asynchronous playback and replay of the teacher's real-time discussions. Echo360 also can be deployed concurrently and non-obstructively while using Wimba, which is designed for delivery of power-point slides and synchronous interactions with online students. The final product of Echo360 is an editable video-file which is placed on a server for student accessibility. Certain tools on Tablets, e.g., MS Word, support freehand marking of assignments, which can be returned to students. These technologies have come a long way; students no longer need to bring individual compact tape recorders into the classroom and request the professor's permission to record her/his lecture!

**The Echo360 System** was developed by the Echo360 System group in partnership with the University of Western Australia. The system provides an opportunity for students to have access to classroom learning in an on-demand basis and frees students from traditional, synchronous barriers to learning. The on-demand option helps colleges and universities engage students anywhere, anytime and on student preferences that permit the combination of full-time or part-time work and full-time access to education.

Acquiring and installing Echo360 system could be expensive for small institutions in that it requires the purchase of hardware platform that includes a capture station with cameras

and microphones to record the video component. Using the Echo360 system also requires a minimum 30-minute wait period after the presentations for transcoding after upload to the Echo360 media server. The captured content is produced as a H.264 video, which is then transcoded to Rich Media, Flash, and vodcast formats on the server [8].

Besides the factors indicated in the U.S. Department of Education report mentioned before [15], the necessary use of a variety of technologies outlined above could also be a possible factor behind the effectiveness of the online mode of learning. The added convenience of remote and synchronous classes, avoidance of a commute, relatively self-paced learning, etc. can all provide incentives to a motivated and mature student.

## Conclusions

This paper explored the technological advances that have changed the nature of distance learning. It gave a brief history of distance learning and examined the recent developments such as the rapid growth of broadband Internet in homes that have allowed for the increase in online education. The history of distance learning at [Our University] over the past decade was reviewed and specific tools and techniques utilized in distance education today were elucidated. We discussed content management systems, development tools, and delivery tools used to facilitate online courses.

We plan to continue our research by exploring how the strengths of these various technologies and other factors come together in impacting the effectiveness and quality of e-learning.

## References

- [1] Boulos, Maged, Taylor, Andrea D., and Breton, Alice (2005). A Synchronous Communication Experiment within an Online Distance Learning Program: A Case Study. *Telemedicine and e-Health*. October 1, 2005, 11(5): 583-593.
- [2] Blakelock, Jane, Smith, Tracy (2006) Distance learning: From multiple snapshots, a composite portrait; *Computers and Composition*, Volume 23, Issue 1, 2006, Pages 139-16.
- [3] Camtasia <http://www.techsmith.com/camtasia/features.asp>
- [4] Dasigi, Venu, and Reichgelt, Han (2009). Issues with Online STEM Education – Assessment and Accreditation, American Society for Engineering Education (ASEE) Southeast Section Annual Conference, April 5-7, 2009.
- [5] Davies, Larry, Hassan, W. Shukry (2001). On mediation in virtual learning environments; *The Internet and Higher Education*, Volume 4, Issues 3-4, 2001, Pages 255-269.
- [6] Debeb, G.E. (2001). “Distance education in African universities: rationale, status, and prospect.” *Newsletter of the International Institute for Capacity Building in Africa*, 3(3), pps. 14-16. <http://www.unesco-iicbaorg/Resources/vol%203%20no%203%20english.pdf>.
- [7] D2L <http://www.desire2learn.com/>
- [8] Echo360 <http://finance.yahoo.com/news/Echo360-Lowers-Total-Cost-of-iw-1105481.html?x=0>
- [9] Funk, M. Leigh (1999). “The State of Distance Learning Technologies Used Within the Post-Secondary Institutions of the University System of Georgia.” <http://edtech.kennesaw.edu/leigh/comps/pc501paper.doc>
- [10] Globule -- The Globule User Guide



- [11] Hart, Jane (2011) "Course & Learning Management Systems", Centre for Learning and Performance Technologies; <http://c4lpt.co.uk/directory-of-learning-performance-tools/instructional-tools-course-learning-management-systems/>
- [12] Hedberg, Sara Reese (2002). "Web-based Education: A New Generation of Distance Learning is Emerging" IEEE Distributed Systems Online, Volume 2, Number 2.  
[http://www.computer.org/portal/site/dsonline/menuitem.9ed3d9924aeb0dcd82ccc6716bbe36ec/index.jsp?&pName=dso\\_level1&path=dsonline/past\\_issues/0102/features&file=dis0102\\_print.xml&xsl=article.xsl&](http://www.computer.org/portal/site/dsonline/menuitem.9ed3d9924aeb0dcd82ccc6716bbe36ec/index.jsp?&pName=dso_level1&path=dsonline/past_issues/0102/features&file=dis0102_print.xml&xsl=article.xsl&)
- [13] Jiang,Guorui, Lan, Junqiang, Zhuang, Xinhua (2001). "Distance learning technologies and an interactive multimedia educational system". *Proceedings IEEE International Conference on Advanced Learning Technologies*, Volume , Issue , 2001 Page(s):405 – 408.  
<http://ieeexplore.ieee.org/stamp/stamp.jsp?arnumber=00943958>
- [14] Maddux, Cleborne, Sprague, Debra, Ferdig, Richard and Albion, Peter (2007) *Editorial: online education: issues and research questions*. Journal of Technology and Teacher Education, 15 (2). pp. 157-166. ISSN 1059-7069. Official URL: [http://www.editlib.org/index.cfm?fuseaction=Reader.ViewAbstract&paper\\_id=24317](http://www.editlib.org/index.cfm?fuseaction=Reader.ViewAbstract&paper_id=24317)
- [15] Means, Barbara, Toyama, Yukie, Murphy, Robert, Bakia, Marianne, and Jones, Karla (2010). Evaluation of Evidence-Based Practices in Online Learning: A Meta-Analysis and Review of Online Learning Studies, U.S. Department of Education Office of Planning, Evaluation and Policy Development, Policy and Program Studies Service, <http://www2.ed.gov/rschstat/eval/tech/evidence-based-practices/finalreport.pdf>.
- [16] Primary Research Group (2002). *The survey of distance and cyberlearning programs in higher education, 2002-2003 edition*. New York.
- [17] Sakai-TSIAP <http://campustechnology.com/Articles/2009/10/14/Innovating-Teaching-and-Learning-with-Sakai.aspx?p=1>
- [18] SmoothDraw <http://www.smoothdraw.com/>
- [19] Sun, Pei-Chen, Tsai, Ray, Finger, Glenn, Chen, Yueh-Yang, and Yeh, Dowming (2008). What drives a successful e-Learning? An empirical investigation of the critical factors influencing learner satisfaction. *Computers & Education*, 50 (2008), 1183-1202.
- [20] USG\_LMS\_Task\_Force, 2011, [http://www.usg.edu/learning\\_management\\_system/documents/USG\\_LMS\\_Task\\_Force\\_Final\\_Report.pdf](http://www.usg.edu/learning_management_system/documents/USG_LMS_Task_Force_Final_Report.pdf)
- [21] Wu, J.P., Tsai, R.J., Chen, C.C, and Wu., Y.C. (2006). "An integrative model to predict the continuance use of electronic learning systems: hints for teaching." *International Journal on E-Learning*, 5(2), pps. 287-302.

**Service learning with a technology presence: bridging the gap between classroom theory and professional experience to fulfill societal needs**

Jessica L. Buck, Ph.D  
Jackson State University  
Department of Technology

Bertiel Harris, Masters Candidate  
Jackson State University  
Department of Technology

Elizabeth Y. McInnis, M.S., Doctoral Candidate  
Jackson State University  
Department of Technology

## ABSTRACT

Service learning is a teaching and learning methodology that connects curriculum with identified community issues and needs. Service learning engages projects that serve the community and build their social and academic capacities. Service learning was based off the views of John Dewey, a philosopher and educator who advanced the concept that active student involvement in learning, insisted that this is an essential element in effective education. He viewed the community as an integral component of educational experiences for both enhancing a student's education and for developing future societies. The need for engaged learning and an implementation of technology will further develop training for students in technological discipline, and will fulfill a societal need.

Service learning is an educational strategy that allows classroom skills and knowledge into practice while serving the community. It combines civic involvement with academic coursework in a manner that benefits both the student and the community. Service learning promotes a community partnership while course objectives are met, students turn classroom theory into practice and gain professional experience, and a pertinent community need is fulfilled.

*Key words: service learning, society/community, civic involvement*

## **Introduction**

Service learning is an instrument, in which students take classroom applications and experiences to assist in fulfilling a societal need. The Virginia Office of Volunteerism and Community Services contended that service learning is an educational process by which participants learn and extend through direct involvement in service that is conducted in and meets the needs of a community. It is coordinated between a school/institution and community service program or targeted community group. This concept encourages the lifelong learning of participants, and includes structured time for participants to reflect on the service experience (<http://www.vaservice.org>). Since technology is such an integral part of life long-learning and our ever-changing society, the union of service learning and technology will afford opportunities that will enable continued growth of a global civilization.

According to the International Technology and Engineering Educators Association (ITEEA), technology is defined as human innovation in action that involves the production of knowledge and progressions that will develop systems to solve problems and lengthen human competencies. Technology also involves advancements, transformations, or modification of the natural environment to satisfy professed requirements and desires (<http://www.iteaconnect.org>). With continuous advancements, transformations, and modifications, the community stands at the vanguard of constant need for technological training and assistance. This renders a need for service. To assist in fulfilling this need, technology students should participate in service learning activities to enhance their awareness of societal needs, and they should identify how they can assist in fulfilling those

needs. In order for technology students on a post secondary level to better assist in fulfilling such a need, educators must

- research, assess, and evaluate technology deficiencies in a community;
- develop students' comprehension on the pedagogy of technology integration;
- identify a communal need such as computer literacy, in which technology students will assist in fulfilling;
- devise training sessions that will minimize computer illiteracy; and
- provide strategic methodology and future recommendations.

Once these objectives are satisfied, students will have more clarity of theory and application acquired in the classroom, and they become better prepared for implementation in real world situations.

### **Service learning implementing technology**

Service learning is simply an extension of classroom curriculum. It allows students to learn from performing services in their respective fields. It provides a great opportunity for students to receive hands-on training. Effective service learning programs challenge students to reflect on their service experiences through such activities as group discussions and journaling (Yi & Lambright, 2010). The need to introduce reflection and self regulation into the learning experience is perhaps the most neglected component of service-learning. However, it is a well established fact that we learn through combinations of thought and action, reflection and practice, theory and application (Kendall, 1988). Effective learning can be achieved while discussing intellectual, civic, ethical, moral, cross-cultural, career, or personal goals (Kendall, 1990; Lisman, 1998). "Students from middle schools are mastering

academic content standards while immersed in hands-on, technology-integrated projects that provide learning experiences that are not usually possible within the confines of the traditional classroom” (Bradford, 2005, p.1). This emphasized that service learning is integral in school learning process. This process becomes more potent with the presence of technology.

Implementing technology into service learning is a major asset. Kurt (2001) asserted that service learning can be a meaningful way to combine service with academic learning in a variety of technology courses. Technology savvy students are eager to take on new roles in service learning. Service learning provides this change, because students become more aware of their positive impact to the community while working on technical projects. “Integrating technology with service learning catches and holds the attention of students who have grown up in the digital age and rely on computers, video games, cell phones and digital music players for their information and entertainment” (Bradford, 2005, p.1). Students are given the opportunity to make advances in technology, especially when they feel it is not foreign in today’s society. With this in mind, students must have a strong technological skill set and be able to develop a method of instruction that will appeal to those of various learning styles and abilities. While technology is being integrated into every subject area, it is the teacher who decides what technology and how much of it to use in his or her classroom. Teachers must stay abreast to the latest technology and trends to prepare students for today’s society. Since technology in the classroom can enhance instruction, it is very important that teacher develop effective way to manage their classroom and the technology used in it. Along with managing the classroom and

incorporating technology, teacher must not lose sight of activities involving critical thinking skills.

### **Technology integration and student comprehension**

Burr (2001) suggested that today progressive learning methods are understood with a require departure from emblematic, set, preconceived objectives because the learning will be student directed. Progressive education occurs as real-life applications are joined with a self-directed series of experiences that create unlimited possibilities. Burr further recommended that increased enthusiasm for learning could happen with the collaboration of progressive education principles and service learning, resulting in *progressive service learning*.

In addition, great sums of persuasive confirmation submits to the benefits of service learning and experiential methods, thus revealing that teachers yet depend on the traditional practices of lecture and teacher-directed educational procedures—not appealing to all learning styles. Traditional practices should, in no way, be dismissed; however, it should include approaches where students are able to apply what has been learned in the classroom. Cohen and Brawer (as cited in Burr, 2001) stated the following:

It is reasonable to assume that in an institution dedicated since its inception to "good teaching," new instructional forms will be tried. However . . . traditional methods of instruction still flourish. Visitors to a campus might be shown mathematics laboratories, the media production facilities, and computer-assisted instruction programs. But on the way to those installations, they will pass dozens of classrooms with instructors lecturing and conducting discussions just the way they and their predecessors have been doing for decades (p. 155).

Service learning is an appropriate teaching and learning approach in which the workplace provides a practical setting for structured problem-based learning experiences.

Blumenfeld, Soloway, Marx et al. (1991) concluded that technology can play a powerful role

in project-based learning. Technology contributes to students' learning by enhancing interest, giving more access to information, providing active representation with the multimedia capabilities of technology, structuring the process to provide more tactical and strategic support, diagnosing and correcting errors more easily, managing complexity and aiding production, and providing potential for motivating students to carry out projects.

### **Example of graduate student involvement**

At a research university in Mississippi, graduate students assisted with a local non-profit agency to create an electronic spreadsheet template that would allow the agency to better organize client information such as e-mail, phone, social network site data and mailing addresses. The information was to be also placed in sub-groups that would categorize the clients. The original request was for a Microsoft (MS) Access 2007 database, but the participants were encouraged to utilize an Microsoft (MS) Excel 2007 program since the instructors were highly proficient. Based on the verbal communication from the Chief Administrative Officer (CAO) of the agency, the MS Excel 2007 spreadsheet would address their immediate needs. However, there were plans for the next service learning project, which would convert the MS Excel 2007 spreadsheet into an MS Access 2007 database.

The Fall 2010 academic semester, is when this venture began. As a part of the professor's syllabus, the students were informed about the service learning project. According to Bringle and Hatcher (1995), courses with service learning objectives should provide opportunity for student reflection, community partnerships, student supervision and assessment, and course assessment and research. In adhering to this philosophy, twenty-four technology education graduate students became orientated with service learning, its concepts, and how service learning reflected their



course objectives. The professor provided the students with a general definition of service learning, and provided three technology education philosophical concepts: progressivism (change), constructivism (building on pre-existing knowledge), and pragmatism (practical approaches).

To better assist the students on their venture, the professor invited a representative from the university's Center for Community & Service Learning to provide an orientation and inform the students about a local Mississippi non-profit agency's need. The agency was inundated with client data, in various forms (i.e. business cards, forms, email addresses, etc.). The agency needed a system in place to better organize and store client data, and to become more skilled in a modern technology application to handle this process.

### ***Methodology***

The class was broken into smaller groups (5 members per group) that focused on logistics, instructions, training materials, and spreadsheet template design and development. Each group had a designated captain who made progress reports to the professors and organized collaboration with other groups. All groups had to work collaboratively in order to progress with their designated responsibilities.

Thirty hours were collectively spent by these groups and the technical advisor to assess the agency's objectives, build the Excel template, creation in-class and take-home learning materials, secure training equipment and facilities, as well as administrative duties and parking permits for the agency participants. Throughout the semester, the students posted their reflections on the discussion board section of Web-CT. This allowed the students to share their learning experiences and post questions to the professor as well as other students. After the students completed their assigned tasks, they invited the

agency representatives (7) to participate in two (2), two-hour courses. The purpose of the training course was to teach the agency representative about the new features in MS Excel 2007, short cut techniques, and they students presented the new template. In addition, the students provide and training modules and a short cut table. Nevertheless, the professor and students wanted to ensure that training and resource material were helpful to the agency representatives.

### ***Instrumentation***

Merranko and Zeolla (2009) stated that in any service-learning project, one must reflect on whether the objectives were mastered. During this project, these reflections caused the students to ponder if their plan of action would benefit the individuals they were serving. As a result, the students have reflected on the following: How did the service learning process link to the essential needs of the participants? Did the participants actually learn the concepts? How could execution of the project be improved for future implementation?

The agency's participants were taught how to properly use MS Excel 2007 and how enter to data on the new template. The learning objectives for the agency's participants were to be mastered during two training sessions. After the completion of the first training session, a survey was administered to the participants to discover whether the participants' needs were met. In addition, survey was used to analyze the quality of the instruction, resources employed, and training materials.

The survey was divided into two sections: instructional materials and instructional effectiveness. Participants were able to rank response based on a 5 point Likert scale (e.g.

1-poor; 2-fair; 3-indifferent; 4-good; 5-excellent. The results of the participant feedback were as follows:

<b>Instructional Materials</b>	<b>Score</b>	<b>Attainment</b>
Quality of the Training Materials	20	100%
Quality of the Electronic Materials Covered	20	100%
Quality of the Work Sample	20	100%
Usefulness of the Materials	20	100%
Quality of the Resources Employed	20	100%

*Table 1: Instructional Material*

<b>Instructional Effectiveness</b>	<b>Score</b>	<b>Attainment</b>
Innovation and Creativity in the Teaching Technique	18	90%
Verbal Communication of the Instructors	19	95%
Eye Contact and Interaction of the Instructors	20	100%
Ability to the Instructor to "Reach" Every Learner	19	95%
Confidence, Carriage, and Conviction on the Subject	20	100%

*Table 2: Instructional Effectiveness*

Overall, the participants indicated that they were satisfied with the instruction and the training materials. However, the students did make stronger efforts to improve verbal communicate and transition of the instructional delivery. The graduate students also modified pedagogical approaches to insure participants of all learning styles were being reached. This was accomplished through lecture, distribution of MS Excel condensed short-cut guide, and interactive activities (e.g. spreadsheet data entries, calculations, mail merge, pivot tables, etc.). The graduate students desired that the participants be 100% satisfied with the instructional materials and effectiveness.

***Methods to improve performance measurement***

Unfortunately, the participants did not share any comments on how we could have improved upon our performance as a class. Although the graduate students strived for perfection, the students continued to strive for improvement. To mitigate this concern, the

graduate students indicated that proper execution of the service-learning project may have been reflective from the participants' mastery of the objectives.

However, the professor evaluated all training materials and student participation projection and made the following construction comments: make transitions from one activity to the next smoother, make sure the participants remain engaged, and provide activities where participants can demonstrate comprehension and mastery. The graduate students believed that it would have been prudent for the class to construct "take home" exercises after both sessions that required the participants to e-mail the instructors a document that proved mastery of the concepts taught. The graduate students also indicated that a "take home" activity would have been a better measure of whether or not the information was properly retained after the participants departed from the classes and returned to their respective offices to apply the knowledge. This was a part of the students' period of reflection.

### **Student reflections**

Billig (2000) asserted that reflections in service-learning should connect the experience, content, skill, and value. The graduate students posted comments on the discussion board using Web-CT. The graduate students indicated that the service-learning experience was fulfilling, and it helped them to better understand the course content. Additional student comments revealed that the project increased the desire to work collaboratively and more effectively. The graduate students indicated that they obtained knowledge from the services that was provided, and they learned the culture of the community through providing instruction for the agency.

Furthermore, Billig contended that reflections should be on-going and used to evaluate the improvement of service for students. The professor provided information that provided foundational service-learning content and technology implementation (i.e. as an instructional aide or to remedy a technology application deficiency). In addition, the professor provided the following assignments and activities: service-learning article reviews, reflection comment postings on Web-CT, verbal reflections during class discussions, a service-learning research and reflection project paper and a classroom presentation at the conclusion of the project. The professor found that the graduate students grasped the technology education course content and were able to apply classroom knowledge during the service-learning project. However, the professor found that the activities should be condensed to allow the students more time to fully execute additional service-learning concepts and reflect on service-learning experiences. The professor did not want there to be a limit on opportunities students had to share their thoughts about the project and exchange ideas.

### **Limitations and future recommendations**

When attempting to teach and implement course objectives, time is of the essence. This may cause the professor to condense some course materials, and it may cause students to rush to complete projects. The professor and students acknowledge that timing was a significant constraint in this project as several weeks were lost due to the participants' scheduling conflicts. It is recommended that this very necessary step be taken in the next project with the agency and future service-learning projects.

The distinctive element of service-learning is that it enhances the community through the service provided, but it also has powerful learning consequences for the students or others participating in providing a service. According to Eyler & Giles (as cited in Folkestad, et al, 2002) service-learning is a form of experiential education where learning occurs through a series of action and reflection as students work with others through a process of applying what they are learning to community problems. In addition, service learning allows the opportunity to deliberate on their experience where students desire to achieve real objectives for the community and deepen understanding all facets surrounding such a service.

Service learning combines experiential learning and community service opportunities. Service learning is distinguished in the following ways: curricular connections, student voice, reflection, community partnerships, authentic community needs, and assessment. Curricular connection is integrating learning into a service project, which is then coupled with student interactivity. Students have the opportunity to select, design, implement, and evaluate their service activity. Then, students' reflection on structured opportunities created to process, establish dialogue, and provide with communication regarding the service learning experience. There should be balance of reflection, and students should have the opportunity to develop a deeper comprehension of classroom application. This may occur when the students are able to become active participants in the learning process while taking the learned theory and utilizing said theory to solve a problem.

## **Conclusion**

There is a demand for technology literacy in lower social economic areas. Some people usually avoid technology and computer utilization for numerous reasons: 1) they have never been properly introduced and instructed on computer technology utilization, 2) they have never been informed on the benefits of using computer technology for professional personal development, and 3) they are unaware of entertainment components. However, completion of proper training will minimize the computer illiteracy issue, and allow give students the opportunity to apply classroom knowledge acquired.

Technology students should participate in service learning activities to enhance their awareness of societal needs. They may assist in efforts in fulfilling those needs and other demands by utilizing classroom knowledge to fulfill as demand of the community in such areas as technology. Such efforts enable technology to serve as a means that continues improving the quality of life for all. Service Learning motivates the student and it also motivates learning. Moreover service learning can help student develop leadership skills teach them how to be involved citizens and give them practice in working with others.

Community partnerships are when partnerships with community agencies are used to identify genuine needs, provide mentorship, and contribute assets towards completing a project. Authentic community needs is when local community members or service recipients are involved in determining the significance and depth of the service activities involved. Well structured assessment instruments with constructive feedback through reflection provide valuable information regarding the positive reciprocal learning and serving outcomes for sustainability and replication. Service-learning is one of the most prominent school-based approaches to involving students in their community (Westheimer

&Kahne, 2000). At its best, community service-learning integrates school or community based service projects with academic skills and content and provides opportunities for structured reflection on the service experience (Cairn & Kielsmeier, 1991). Since service learning allows students the opportunity to learn through experiences, student may develop competencies that will prepare them for the contemporary workforce. In addition, service learning creates a positive connection between schools and the community.

Since technology is ever-changing, some community entities may find it challenging stay abreast to current trends. According to Abravanel (2003), students who have been involved in high-quality service-learning programs demonstrate an increased sense of personal and social responsibility and are less likely to engage in “risk” behaviors. At the same time, these students show obtain an inspiration to learn. This renders higher attendance rates and increased academic performance. Service-learning has a positive effect on interpersonal development, student comprehension, and team work. Students see themselves as positive contributors to their community, feeling they can impact the world around them.

## **References**

Abravanel, S. A. (2003). Building community through service-learning: the role of the



community partner: ECS Issue Paper. Denver: Education Commission of the State.

Billig, S. H. (2000). Research on k-12 school based service-learning: the evidence that builds.

*Phi Delta Kappan*, 658-664. Retrieved from <http://www.servicelearning.org/library/resource/1698>

Bradford, M. (2005). Motivating students through project based-service learning. *T. H.E. Journal*, 32 (6), 29.

Bonnette, R. (2006). Out of the classroom and into the community: service learning reinforces

classroom instruction. *Technology Teacher*, 65 (5), 6-11.

Burr, K. L. (2001). Building for hope: progressive service-learning enhances education. *Journal of Industrial Teacher Education*, 38 (4), 25-30.

Bringle, R. G. Hatcher J.A. (1995). A service-learning curriculum for faculty. *Michigan Journal of Community Service-Learning*, Article 12, p.112-122.

Cairn, R. W., & Kielsmeier, J. C. (Eds). (1991). Growing hope: a sourcebook on integrating youth service into the school curriculum. Roseville, MN: National Youth Leadership Council.

Chadd, J. & Anderson, M. A. (2005). Illinois work-based learning programs: worksite mentor knowledge and training. *Career and technical education research*. 30(1).

Eyler, J., & D. E. Giles, J. (1999). *Where's the learning in service-learning?* San Francisco: Jossey-Bass.

Ferguson, D. (2002). Community service-learning initiatives bridge the gap between America's technology haves and have-nots. *Chronicle of Higher Education*, 48 (43), 1-2.

Folkestad, J., Senior, B., & DeMiranda, M. (2002). The implications of service-learning for technology studies. *Journal of Technology Studies*, 28(1), 52-58. Retrieved from Academic Search Premier database.

Heiselt, A., & Wolverton, R. (2009). Libraries: partners in linking college students and their communities through service-learning. *Reference & User Services Quarterly*, 49(1), 83-90. Retrieved from Information Science & Technology Abstracts (ISTA) database.

International Technology and Engineering Educators Association (ITEEA). Retrieved from <http://www.iteaconnect.org>.

- Kansas State Univ., M. (1995). Service learning benefits students, communities. *Rural Clearinghouse Digest*, 2(2). Retrieved from ERIC database.
- Kendall, J. C. (1988). From youth service to service-learning. Facts and faith: A status report on youth service. Washington, DC: William T. Grant Foundation.
- Kendall, J. C. (1990). Combining service and learning: A resource book for community and public service (Vol. 1). Raleigh, NC: National Society for Experiential Education.
- Kurt, M. (2001). Technology education students make a difference through service learning. *Technology Teacher*, 61 (3). 30.
- Merranko, S. & Zeolla, H. (2009). *Student Service Learning Handbook*. Retrieved from <http://www.csmd.edu/servicelearning/StudentServiceLearningHandbook.html>
- Lisman, D. C. (1998). *Toward a civil society: civic literacy and service learning*. Westport, CT: Bergin & Garvey.
- Swaminathan, R. (2007). Educating for the "real world": the hidden Curriculum of Community Service-Learning. *Equity & Excellence in Education*, 40(2), 134-143. Doi: 10.1080/10665680701246450.
- Yi, L., & Lambright, K. T. (2010). Looking beyond the undergraduate classroom: factors influencing service learning's effectiveness at improving graduate students' professional skills. *College Teaching*, 58(4), 118-126. Doi: 10.1080/87567550903583777
- Talbert, M. (2003). Combining service learning with graduate education. *Journal of Professional Issues in Engineering Education and Practice*, 129 (4), 211-215.
- Virginia Office of Volunteerism and Community Service (n. d.) Service learning. Retrieved June 29, 2007 from <http://www.vaservice.org>.
- Westheimer, J., & Kahne, J. (2000). Service learning required. *Education Week*, 19(20), 52.

## **What Works in Teaching Engineering Statics**

JIM SHIH-JIUN CHEN  
ALANI INTINTOLO  
Department of Mechanical Engineering  
Temple University  
Philadelphia, Pa 19122  
Biographical Information

Dr. JIM SHIH-JIUN CHEN

Dr. Jim Shih-Jiun Chen is a professor of mechanical engineering at Temple University. His research and teaching interests are in the areas of fluid mechanics, heat transfer, and wind energy. He has published more than 100 articles in fluid flow, temperature measurement and control, film cooling, jet impingement, accelerated/controlled cooling, melt spinning, and wind energy. In education, he has advised students winning national and international competitions in designing energy efficient systems. Dr. Chen received the Distinguished Faculty Award from the College of Engineering at Temple University in 1996. He has been a member of ASME since 1986. Since Fall 2007, he has taught over 300 students in ten (10) sections of Engineering Statics.

ALANI INTINTOLO

Alani Intintolo was a junior in the mechanical engineer program when she worked as a Diamond Peer Teacher (DPT) during the Spring 2011 semester. She once considered changing her major to secondary education. This DPT program fulfills her wish to be both an engineer and a teacher. She has helped many students in the Engineering Statics class and has made some friends. She is now a senior at Temple University.

# What Works in Teaching Engineering Statics

## Abstract

Engineering Statics is a critical fundamental course for subsequent mechanics courses such as Engineering Dynamics, Solid Mechanics, Fluid Mechanics, etc in various disciplines in engineering. After teaching ten (10) sections of Engineering Statics since Fall 2007, the lead author summarizes and illustrates what works in teaching Statics to more than 300 students. Traditional methods of lectures, homework assignments, and exams only work for top, motivated students in the class. Most students, who grow up in the digital age, prefer approaches involving real senses of touch (hands-on) and sight (graphs and demonstrations). Active learning along with teamwork also contributes to a good learning practice.

The Diamond Peer Teacher (DPT) Program was experimented for the first time in Engineering Statics during the Spring 2011 semester. The program provides upper-level undergraduates at Temple the opportunity to experience the challenges and rewards of college-level teaching, to develop their own pedagogical skills by working closely with their faculty mentors, and to provide supplemental instruction in lower-level courses. The DPT had a GPA over 3.5 and received an A in Engineering Statics last year. When the student performance of two (2) sections were compared, section 1 without and section 2 with the peer teacher, the average exam scores were identical during the first exam, but the average scores were higher by 10 percentage points in section two during the final exam. This paper discusses how the DPT enhances active learning and promotes study groups. Excerpts from the final report by the DPT are also included.

**Keywords:** Hands-on, study group, teamwork, Diamond Peer Teacher.

## Introduction

Engineering Statics is a critical fundamental course for subsequent mechanics courses such as Engineering Dynamics, Solid Mechanics, Fluid Mechanics, etc in various disciplines in engineering. The prerequisites of Engineering Statics are Calculus I and Physics I and the corequisite is Calculus II. The lead author has taken the leading role of teaching Engineering Statics since 2007. Over 300 students from various engineering programs including Civil Engineering, Environmental Engineering, Electrical Engineering, and Mechanical Engineering have enrolled in the ten (10) sections taught by the lead author.

In accordance with the ABET 2000 guidelines [1], the syllabus clearly states five Course Learning Objectives (CLOs) as:

1. Utilize Free-body Diagrams to apply concepts of equilibrium to particles or rigid bodies. (PO A)
2. Analyze forces and moments in two and three dimensions, using calculus and vector analysis. (PO A, E, n)
3. Utilize concepts of centroids and moments of inertia (PO n)

4. Analyze structures including trusses, frames and machines (PO A, E, n)
5. Understand friction and its application (PO A, E, n)

The corresponding Program Outcomes or Student Outcomes are:

**A.** Ability to apply current knowledge and applications of mathematics, science, engineering and technology.

**E.** Ability to identify, formulate, analyze and solve technical and engineering problems.

**n.** Knowledge of chemistry, or biology, and calculus-based physics.

Traditional methods of lectures, homework assignments, and exams only work for mature and motivated students in the class. Yet, most instructors still adopt the old generation's study-and-drill approach, which is outdated and ineffective for long term learning. Today's students grow up in the digital age, and prefer approaches involving real senses of touch (hands-on) and sight (graphs and demonstrations). Steif and Dollar [4] proposed that senses of sight and touch improve the students' comprehension of forces and moments in Statics. They have developed learning modules which involve collaboratively manipulating objects and responding to conceptual questions. A newly published book [2] offers information on the most effective ways that students process information; store it in their long-term memories, and how that affects learning for long-term retention. It provides a handy introduction to the 'why and how' of engaging students in the STEM (Science, Technology, Engineering, and Mathematics) disciplines in the learning process. Among various methods contributing to good learning practice described in the book, teamwork and active learning have been effectively adopted by the lead author in Engineering Statics instructions at Temple University. A new Diamond Peer Teacher Program, developed at Temple University enhances active learning and teamwork.

The aims of this paper are (1) to show how hands-on experience and visual demonstration help students to construct FBDs and apply force and moment principles, and (2) to demonstrate the effectiveness of active learning and teamwork, which is further enhanced by Temple's Diamond Peer Teacher Program.

### **Construction of Free-Body Diagrams**

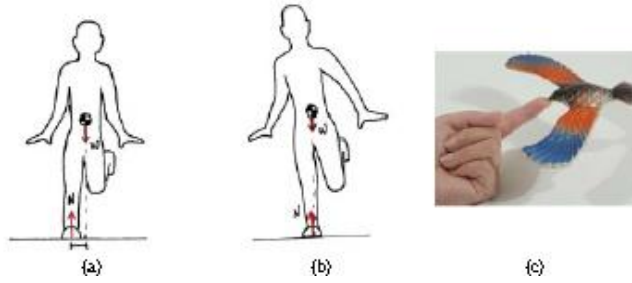
If the students have adequate knowledge of trigonometry, calculus and vector algebra, the single most important concept in Engineering Statics is the construction of free body diagrams of rigid bodies. First, common types of force application on mechanical systems for analysis are introduced. Types of contact and force origin to be modeled include cables, rods, beams, smooth surfaces, rough surfaces, roller support, freely sliding guide, pin connection, fixed support, weight, and spring in two dimensions, Three dimensional modeling and analysis are introduced and discussed, but most homework and exam problems are two dimensional. Detailed step-by-step procedures for constructing FBDs and for solving problems are given in [2]. Students are told to read these thoroughly and follow the steps closely in doing homework assignments and group quizzes in the class.

Sketching FBDs on the blackboard is the most widely used method for teaching students how to isolate a system and draw a FBD. Key steps of constructing FBDs for problem solving include: (1) identify clearly the known and unknown quantities, (2) isolate a system by choosing a single body, a section of a rigid body, or a system of connecting bodies, drawing its complete FBD, (2) identify the external boundary and label all known and unknown quantities (forces and moments), (3) choose a convenient set of references axes and moment center for equilibrium force and moment equations, (4) match the number of independent equations with the number of unknowns in each problem, usually three each for two-dimensional problems, and (5) carry out the solutions and check the results with additional equations or alternative methods.

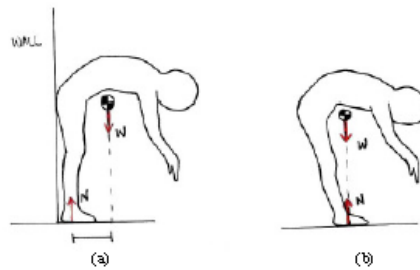
### **Hands-On and Visual Demonstration**

Many students struggled with the selection and construction of FBDs and the identification of known and unknown forces and moments. After showing numerous examples, the authors found that most students had a much better understanding when students are engaged in hands-on and/or sight experience when the instructor explains the force and moment principles. As shown in Fig. 1(a), this demonstration was borrowed from an exhibit in Philadelphia's Franklin Institute. The instructor asked every student in the class to stand up and balance his/her body with one foot. After a while, every student found a balance by shifting his/her weight to above the foot. They also found that the one-foot stand was unstable as shown in Fig. 1(b), when the CG is slightly shifted, a moment would cause the body to lose balance. A balancing bird was then demonstrated to show its unconditional stability. A restoring moment (couple) is produced as a result of CG below the center of support where the finger tip meets the bird's beak tip. Figure 2 is another demonstration of force and moment principles from the Franklin Institute.

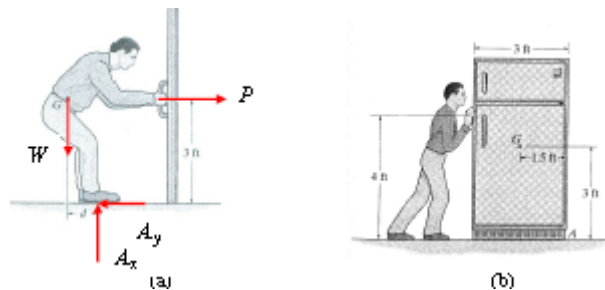
Figure 3(a) shows a person pulling a door with a pulling force  $P$ . All external forces (in red) are identified and shown in the correct directions. The three unknowns are  $P$ ,  $A_x$ , and  $A_y$ , which can be solved using the two force equations and one moment equation. Most students choose point A to be the moment center so as to simplify calculations, but a different center can be used to check the solutions. When Fig. 3(b) is compared with Fig. 3(a), two differences are identified. First, the hands are pushing instead of pulling so that the force is in the opposite direction. Second, the two feet in Fig. 3(b) are spread so that the person is statically indeterminate to gain



**Fig. 1** (a) A person standing on one foot is unstable because of a clockwise moment (couple) is produced by the distance between the two equal but opposite forces, (b) the person becomes conditionally stable by shifting the center of gravity (CG) to above the foot to satisfy  $\Sigma F = 0$  and  $\Sigma M = 0$ ; however, case (b) becomes unstable if the CG is slightly shifted to left or right, (c) to maintain unconditional stability, CG must be below the center of support, as shown by the selfbalancing bird.



**Fig. 2** (a) A person with his back and feet against the wall cannot bend down his body because a clockwise moment is produced by the distance between the two equal but opposite forces, (b) when the person moves away from the wall and shifts the center of gravity (CG) backward to right above the feet, the body becomes conditionally stable because the equilibrium equations of  $\Sigma F = 0$  and  $\Sigma M = 0$  are satisfied.



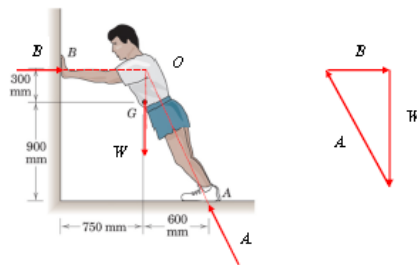
**Fig. 3** (a) A person pulling the door with two feet together is stable and statically determinate, (b) a person pushing the refrigerator with two feet apart is stable and statically indeterminate, i.e., the rigid body has excessive fixity or redundancy.

more stability. The extra supports constitute redundancy which is preferred in the real world. Students were told that the analysis and design of structures and systems with redundancy will be discussed in upper level courses.

Figure 4 shows a person pushing the wall horizontally. After constructing the FBD, the problem can be solved with 3 unknowns ( $B_x$ ,  $A_x$ ,  $A_y$ ) with the three independent force and moment equations. An alternative method can be used by considering that three forces in equilibrium must be concurrent (at point  $O$ ) and must form a force triangle. The unknown force components can be solved using the simple trigonometric functions. As the pushing force  $B$  increases, the friction at  $A$  must also increase by moving the feet farther away from the wall.

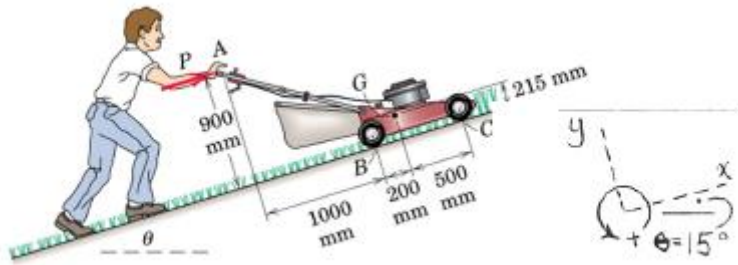
Figure 5 shows how a careful choice of the reference axes and a FBD can simplify the analysis. First, choosing the  $x$  axis along the inclined surface and  $y$ -axis normal to the inclined surface simplifies the force components when normal and frictional forces are considered. Second, a FBD of the person with two feet separated shows that this body is statically indeterminate. Therefore, a FBD of the lawn mower indicating the three unknown force components  $N_B$ ,  $N_C$ , and  $P$  should be used for the two-dimensional problem. The three unknown forces can be solved using two force equations (in the  $x$  and  $y$  directions) plus one moment equation or two moment equations (about moment centers  $B$  and  $C$ ) plus one force (normal to the inclined surface) equation can be used [3].

As shown in Fig. 6(a), trusses were demonstrated to the students using the K'nex joints and rods. Fig. 6(b) shows that the four bars pin-jointed to form a square is collapsible. By adding a cross bar to the square, students quickly learned that the triangle element is rigid. Therefore, the basic element of a plane truss is the triangle and various simple trusses can be built by adding two member bars ( $m$ ) for each joint ( $j$ ) added. For any plane truss, the equation of a plane truss,  $m = 2j - 3$  is satisfied is the plane truss is statically determinate internally. To simplify the analysis, each member is assumed to be a two-force (tension or compression) member and each joint is assumed to be a pin joint so that it is free to rotate.

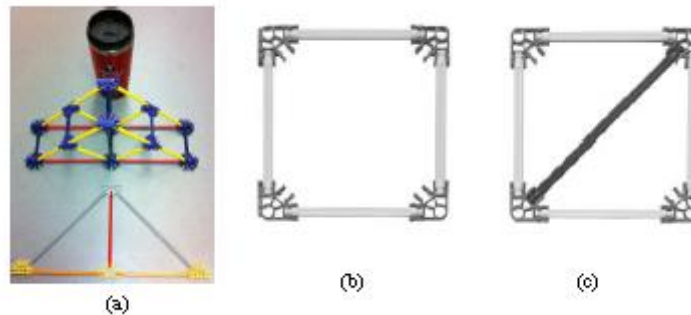


**Fig. 4** A person pushing the wall horizontally is stable with three forces being concurrent at point  $O$  so that  $\Sigma M_o = 0$  and forming a force triangle so that  $\Sigma \mathbf{F} = 0$ . The person is statically determinate if the friction between the hands and the wall is negligible.





**Fig. 5** Careful choices of the reference axes and FBD simplify the analysis [3].



**Figure 6** Hands-on with K'nex trusses: (a) simple plane trusses, (b) collapsible structure, (c) rigid structure.

### Active Learning and Teamwork

During the first week of each semester, every student was asked to fill out a data sheet, which should include the contact information of two other classmates. Students were then encouraged to form study groups in and outside the classroom. To promote teamwork, pop quizzes lasting 15-20 minutes were given biweekly to teams of three (3 students forming a triangle) in the class with the assistance of the Diamond Peer Teacher, whose function will be elaborated in the next section. A group of 4-8 students often studied together one hour before the class or during the lunch time. They either found an empty classroom where they can teach each other using the blackboard or they worked in the lounge area as shown in Fig. 7.



**Figure 7** A study group of 4-8 students before the class and during lunch time.

### **Diamond Peer Teacher (DPT)**

The Diamond Peer Teacher Program was experimented for the first time in Engineering Statics during Spring 2011. The program provides upper-level undergraduates at Temple the opportunity to experience the challenges and rewards of college-level teaching, to develop their own pedagogical skills by working closely with their faculty mentors, and to provide supplemental instruction in lower-level courses. The peer teacher must have a cumulative GPA 3.25 with 60 credit hours by end of the semester in which they are applying. In addition, the peer teacher must have earned at least an A- in the course (or equivalent) for which they are applying to be a Peer Teacher. Program requirements include (1) attending an all-day Peer Teaching Institute workshop, (2) committing 12-15 hours per week during the semester to attend the class in which they are a Peer Teacher; to provide regularly scheduled tutoring / class contact for students in the class (one-two hours for every hour of class); to keep two hours of “office hours” per week to meet individually with students; to attend weekly meetings with their Faculty mentor; to attend scheduled meetings with other Peer Teachers, (3) submitting a mid-term selfassessment, and (4) submitting a final report / self assessment on their experience at the end of the semester.

Excerpts of the final report (as part of a one-credit course: Peer Teacher Internship) are given below.

#### **Program Purpose:**

“This program fulfilled both of its primary goals – experience on my part and education on the part of the student successfully. I have found that some of the most pivotal turning points in my understandings of course concepts have not been due to the teacher, but due to the teachings from a classmate who describe things in a different but enlightening way. My mentor and I stressed the concept of contacts and study groups. As the semester wore on, I began to notice many people in the class making connections and working in groups when applicable. This was more evident to me in terms of office hours, where the caliber of questions asked seemed to increase in difficulty towards the end of the semester suggesting that students were now using

their formed networks to ask more-challenging questions. I was fortunate enough to have students utilize my office hours and I do believe that they were beneficial. There was also a very high turnout at nearly all of the recitation sessions I taught in which I often tried to stress trickier concepts and work through problems. The test average from the first exam to the second exam increased by 20% (from 60/100 to 73/100), which was fantastic news and verifies my feelings that these services were beneficial. After providing a list of students tutored after the first exam, I was given feedback verifying the increase in grades from the first to second exam for those students. Each student showed improvement, with the largest grade increase being 36%!"

#### Tell a Friend

"I am now more prepared for a Teaching Assistant position if I choose to apply for one during my graduate studies. If I had a friend who also wanted an introduction to teaching but did not have a loose schedule in regards to workload and time, I would definitely suggest that they apply for a position within their respective college. I would also suggest this program to a classmate if she had helped me learn a class previously; I believe that the ability to teach a friend difficult concepts without making them feel inferior is one of the best skills to have for this program. A positive attitude is also a must. The most satisfaction I received from this program was when I could recognize that a student having difficulties finally shifted from having the ability to solve one specific problem to gaining the ability to solve any problem of containing those concepts. This happened most during study hours, where after letting a student work through a problem and bringing to attention certain mistakes, they could later work through an entire problem without a hitch. When this occurred, I felt assured that a student understood a concept as well as accomplishment as a Peer Teacher."

#### The Struggle

"Unfortunately, there are also less positive experiences when trying to teach, especially an entire group of students with different needs and different levels of dedication. At one point during a recitation section I had to assert myself more than normally to regain the attention of a particular group of students. In my opinion, they were being disrespectful to the classroom setting; however, from my own experiences I know that I have done the same at times, and these instances were not malicious and not even intentional, so I did not read more into the situation than was necessary. Other times students would make comments that hinted at their desire for the easiest option or minimal effort on their own parts, but this just fueled me to ask more of them.

At the end of the day (or in a following recitation), these "negative" experiences seemed to boost respect and class response! If one is quick to temper or easily frustrated, I would not recommend that he apply for a position as a Diamond Peer Teacher. To those that want to give back in the learning experience, help others reach academic success, and challenge their own abilities while retaining the ability to maintain a positive outlook: apply to be a DTP!"

Comments from students as well as suggestions for future DPTs regarding what to do (e.g., explaining what each problem-solving step is and why it is being taken) and what not to do (e.g., solving homework problems for students) are summarized in Appendix

#### **B. Results of Teamwork and DPT**

Table 1 lists how four (4) students performed in major exams during the Spring 2011 semester.

One might have guessed that Student 4 was the team leader, pictured in Fig. 7, who improved his own learning by leading the group study and by teaching the weaker students (Student 1 and Student 2) in the group. Student 1 and Student 2 improved their grades from very poor showing in Exam 1 to final grades of B- and C, respectively. Student 3 failed the course last year and did much better this time around. He attributed to his progress to the study group which met 2-3 times a week, usually during the lunch time and sometimes just after the class. Student turned to be Mr. Joseph Stoney, who has received the award to become a DPT for Engineering Statics in the Spring 2012 semester.

**Table 1.** An Exemplified Study Group’s Exam Scores (out of 100, with DPT, Spring 2011)

	Exam 1	Exam 2	Final Exam	Final Grade
Student 1	30	79	89	B-
Student 2	44	69	78	C
Student 3	75	81	90	B+
Student 4	80	100	92	A

Direct assessment of student performance based on major exams is summarized in Table 1. Over 300 students have enrolled in 10 sections of Engineering Statics taught by the lead author since 2007. Students have improved by 15-20 percentage points from the pretest (10 multiple –choice questions of Math and Physics) to the posttest with the same 10 questions. After the student direct assessment between the four (4) sections with recitations (one hour weekly) by TAs and the other four (4) sections without recitations (usually evening classes) were compared, no difference was found in the student progress and performance. The average class size is 30-36 from Fall 2007 to Fall 2010. However, when the student performance of two (2) sections were compared in Spring 2011, section 1 without and section 2 with the DPT, the average exam scores were identical during the first exam, but the average scores were higher by 10 percentage points in section two for the final exam. This suggests that the effect of DPT was not significant after 5 weeks, but the presence of DPT became more and more beneficial in the last two thirds of the semester. What did we learn? Patience is a virtue and a DPT is more effective than a TA.

**Table 2. Student Exam Scores (out of 100) in Section 1 (36 students, without DPT) and Section 2 (38 students, with DPT)**

	Pretest	Exam 1	Exam 2	Posttest	Final Exam
Section 1	63	63	N/A	85	64
Section 2	64	60	73	85	74

## Pass the Baton

The DPT wrote in her report: “Everyone learns differently, and as the semester passed, the diversity of learning became clear. Some students learn best by teaching, as was clearly the case for one particular member of the class. It was great to see someone take command of his education while being such a high influence on others – he (Mr. Joseph Stoney, pictured in Fig. 7) would make a great candidate for this program!” The student (Mr. Stoney) happily responded by applying to the DPT program and he wrote: “In Engineering Statics during the Spring 2011 semester approximately 8 students including myself studied together throughout the semester. I quickly grasped the concepts and theory of our topic and was very helpful to others. I set up study sessions for exams and utilized empty classrooms and 6<sup>th</sup> floor lounge to provide examples for the entire study group. It quickly became routine to come in an hour early for class and hold a student recitation for the early arrivals before lecture began. I enjoyed helping other students and have now been seeking out any opportunity to help others understand any topic we are working on. I look forward to helping others throughout my time at Temple University through the Diamond Peer Teaching program.” Just before this paper is finalized, Mr. Joseph Stoney has received a Diamond Peer Teacher award for Engineering Statics in Spring 2010. It appears that the DPT baton has been passed.

## Summary

By requiring the prerequisites and giving students a pretest, students’ basic knowledge of Mathematics and Physics was reinforced. Instructions with visual demonstrations (sense of sight) improve students’ comprehension of FBDs and problem solving techniques. Hands-on experiences (sense of touch) with the balancing bird and K’nex trusses as well real-world examples (each student did the balancing acts of standing, bending, pushing, pulling) improve the student’s ability to apply force and moment principles to solve Engineering Statics problems.

Schematics of FBDs enhance the student to analyze a single rigid body or a system of components by selecting convenient references axes and moment centers. By investigating how forces and moments affect a structure or design, students can come up with a new design and thus demonstrates their synthesis skills. The success of learning Engineering Statics can be measured in Bloom’s Taxonomy, from Knowledge and Comprehension, to Application and Analysis, and finally to Synthesis, as summarized in Appendix A. Since this is a sophomore course, students have not developed the highest form of learning – Evaluation by judging a new design. Students are expected to grasp the “Evaluation” skill through upper level engineering courses.

The Diamond Peer Teacher Program is a highly beneficial program to both the student and the peer teacher. The Peer Teacher gains experience, insight, and leadership skills. The student is benefitted by more pathways of learning and a friendly connection for help that falls somewhere between the levels of peer and superior. However, this program is not for anybody. This program is for those special individuals who care about

helping others to learn and succeed and who have patience and skills to work with the diversity of Temple student body. We wholeheartedly hope and expect that the DPT program will succeed and continue in the future.

The success strongly depends on class teamwork emphasized by both the instructor and the DPT.

**References:**

1. ABET Student Outcomes, [http://www.foundationcoalition.org/home/keycomponents/assessment\\_eval/ec\\_outcomes\\_summaries.html](http://www.foundationcoalition.org/home/keycomponents/assessment_eval/ec_outcomes_summaries.html)
2. Mastascusa, E. J., Snyder, W. J., & Hoyt, B. S. (2011), *Effective Instruction for STEM Disciplines: From Learning Theory to College Teaching*, Jossey-Bass, A Wiley Imprint.
3. Meriam, J. L. & Kraige. L.G. (2010), *Engineering Mechanics – Statics*, 6th Edition, Wiley.
4. Steif, P.S. & Dollar, A. (2005), "Reinventing the Teaching of Statics," *Int. J. Engrg. Ed.*, Vol. 4, pp. 723-329, Templus Publication.

## Appendix A. Bloom's Taxonomy used in Engineering Statics

Category	Example and Key Words (verbs)
Knowledge: Recall data or information.	Examples: Recite the laws of sines and cosines. Quote the 1 <sup>st</sup> and 3 <sup>rd</sup> Newton's laws of motion. Recall dot product and cross product.
Comprehension: Understand the meaning and interpretation of instructions and problems.	Examples: Rewrite the principles of transmissibility and concurrent forces. State a problem in one's own words with sketches.
Application: Apply what was learned in the classroom into surrounding real-world problems.	Examples: Apply principles of forces and moments to determine unknown quantities for equilibrium of particles and rigid bodies.
Analysis: Separate a system into component parts. Determine what principles to apply. Distinguish between facts and interferences.	Examples: Learn how to construct FBDs* by considering a single body, a section of a rigid body, and a system of connected rigid bodies. Select reference axes and moment centers.
Synthesis: Build a structure or machine from diverse elements, with emphasis on new ideas.	Examples: Design a new machine or a new process to perform a specific task so as to gain a mechanical advantage or stability.
Evaluation: Make judgments about the value of ideas or materials. Explain and justify a new design.	Examples: Select the most effective solution by examining alternatives. This should be implemented in upper level courses.

FBDs\*: Free Body Diagrams

## Appendix B. Student Feedback and Comments on DPT:

*What aspects of the course or the instructor's approach contributed most to your learning?*

- “The instructor explained the problems in recitation very clearly which broadened understanding for the material.”
- “Always chose good examples.”
- “Easily accessible and approachable.”
- “She always came well prepared for class.”
- “Gave in-depth examples, made sure people's questions were answered and clear.”

*What aspects of the course or the instructor's approach would you change to improve the learning that takes place in the course?*

- “I guess her only flaws would be that sometimes she assumed we knew certain concepts.”

-“I am a believer that instructors of any level should be confident and in some ways controlled. Alani was good with the material, and would be great again, and hopefully she has learned to control the classroom environment a little more.”

-“More interactive classroom.”

-“Not just give equations; derive them so we understand where the equation came from.”

-“She should be more thorough, explain slowly and more carefully.”

#### *What works in recitation?*

-Give examples to show the techniques learned in class. The professor teaches the concepts; the peer teacher reinforces those concepts and shows them in action.

-Explain and show that (in most cases) there is not one correct approach to a statics problem, but multiple approaches and techniques that can be used to find the answer.

-Explain what each problem-solving step is and why it is being taken.

-Engage the students by encouraging them to lead you through the process. Ask them questions on what the next steps should be and why a step was taken keeps students attentive to the problem.

#### *What does not work in recitation?*

-Work on homework problems: It is helpful to work on similar concepts that students must be able to execute for their assignments, but working out real homework problems for students often leads to an inability on the students' behalves to do their work independently.

-Allow students to talk outside of conversations related to solving the problem.

-Spend the majority of time on one student's questions: if there is a student struggling to understand a concept and this is taking too much of the class' recitation time, the peer teacher should suggest a separate tutoring session to address those issues so that everyone can benefit from the recitation.



**Deflection Part I: An Alternative Mechanics of Materials  
Approach Using Foundational Theory and Modern Engineering  
Tools**

J.B. Conrad

United States Coast Guard Academy, New London, CT

J.M. Ryan

United States Coast Guard Academy, New London, CT

C.J. Egelhoff

United States Coast Guard Academy, New London, CT

E.M. Odom

University of Idaho, Moscow, ID

# **Deflection Part I: An Alternative Mechanics of Materials Approach Using Foundational Theory and Modern Engineering Tools**

J.B. Conrad<sup>1</sup>, J.M. Ryan<sup>1</sup>, C.J. Egelhoff<sup>1</sup> and E.M. Odom<sup>2</sup>

<sup>1</sup> United States Coast Guard Academy, New London, CT

<sup>2</sup> University of Idaho, Moscow, ID

## **Abstract**

Here we present an alternative approach to solving beam deflection by applying energy methods to the moment curvature equation and integrating numerically. The approach capitalizes on fundamentals augmented by Castigliano's Second Theorem and the Heaviside step function, together with a modern equation solver. By carefully writing correct governing equations and then using a modern equation solver, the analyst can save time on calculations and spend additional time contemplating the meaning and usefulness of the results.

By way of examples, we demonstrate this straight-forward, five-step approach using simple and challenging beam deflection problems found in classical publications. In this paper, we solve beams of uniform cross-section, non-uniform cross-section and statically indeterminate loadings using the alternative approach. We believe this alternative approach could be successfully introduced and mastered at the undergraduate Mechanics of Materials level as one of several methods available for deflection determination.

## **Introduction**

Calculating deflection is one of the most difficult skills to learn in Mechanics of Materials. Usually multiple methods are presented at the undergraduate level, each with its own set of stumbling blocks and mathematical difficulties when used for any beam with more than a simple load. Using the moment curvature equation and integration approach requires continuity equations for multiple neighboring sections of the beam. The area-moment method depends on manual graphical skills and is becoming impractical. The superposition method is always appealing but soon the analyst discovers how easily the variables are confused in the application to real loadings and how few cases can be found within even the most complete-looking handbooks. Discontinuity functions seem easy with their polynomial-like integrations, but solving for integration constants can be vexing and the process is tedious. Trying to seek help from computational tools presents other complications and confusion. Until now.

The alternative approach described herein applies a numerical integration step to the approach presented by Professor Ju in his course notes and in an article [1]. Professor Ju's approach is based on Castigliano's Theorem and the use of Heaviside step functions to write the moment equation. If performed by hand, this approach is algebraically intense. However, the boundary conditions are embedded in the formulation, and once created, the formulation is ready for

numerical integration. This keeps the problem solution in generalized variable form until the numerical solution is accomplished. Overall, the process consists of the following steps:

- (1) applying a dummy load, solve for static support reactions,
- (2) writing a moment equation in Macaulay form augmented with Heaviside step function variables,
- (3) taking a partial derivative of the moment equation with respect to the dummy load,
- (4) re-writing the moment equation and eliminate the dummy load and finally
- (5) using the results of steps 3 and 4 to develop the deflection equation using Castigliano's Theorem which is applied parametrically to create a deflection curve for the entire length of the beam.

The positive aspects of this process include (a) the governing equation writing is systematic and straight-forward since it relies primarily on knowledge of statics and moment equations, (b) the generalized form allows maximum usefulness and (c) since students select their personal equation-solving software, the coding proceeds quickly to obtain results.

Before computers were ubiquitous, engineers designed stepped and tapered shafts using elegant but time-consuming graphical techniques [3-4]. With the availability of scientific calculators and mainframe computers, semi-graphical and computer-programmed techniques appeared [5-7]. In today's undergraduate Machine Design textbooks, we see few general approaches to the solution of deflection for stepped or tapered shafts; one approach is graphical and other approaches use some form of discontinuity equations [8 - 12].

### **An Alternative Mechanics of Materials Approach to Solve for Deflection**

We present an energy method based solution for real life shaft geometries and loadings. The method stays generalized and requires only knowledge of free body diagrams, writing moment equations, and Castigliano's Theorem to set up the problem solution into a form that is solved using an equation solving computer program. What is different in this paper, is the use of Heaviside step functions to write the moment equation, a virtual axis identified by the variable  $\xi$  which specifies the point of interest for finding a deflection, and a user-defined function to specify the diameter along the shaft during numerical integration [13].

By Castigliano's Theorem the deflection is based on the strain energy,  $U$ , stored in an elastic beam loaded in bending. The strain energy is given as:

$$U = \int_0^L \frac{M^2}{2EI} dx \quad (1)$$

The deflection,  $\delta_i$ , at a location,  $\xi_i$ , is given as the partial derivative of the strain energy with respect to a load at the " $\xi_i$ " location.

$$\delta_i = \frac{\partial U}{\partial P} = \int_0^L \left( \frac{M}{EI} \right) \left( \frac{\partial M}{\partial Q} \right) dx \quad (2)$$

The solution process to evaluate the integral can be described using five steps as follows:

Step 1: Draw free body diagram (FBD) with dummy load  $Q$ , at secondary axis location,  $\xi$ , and solve for reaction forces using statics.

Step 2: Write the moment equation  $M(x, \xi)$  for the entire length using discontinuity terms coupled with a Heaviside function  $H(x, \xi)$ .

Step 3: Take the partial derivative with respect to the dummy load,  $\frac{\partial M(x, \xi)}{\partial Q}$

Step 4: Set  $Q=0$  and write  $M(x, \xi)$  for  $Q=0$ .

Step 5: Write the integral  $\delta_\xi = \frac{-1}{x} \int_0^1 \left[ \frac{\partial M(x, \xi)}{\partial x} \cdot \frac{\partial M(x, \xi)}{\partial Q} \right] dx$ , and then solve for any  $\xi$  using equation-solving software. In this work, we have used EES<sup>®</sup> and TK Solver<sup>™</sup>.

To demonstrate the utility of this approach, a challenging shaft geometry and loading by Hopkins [14] was selected and is shown in Figure 1. It should be noted that this is a shaft that has six changes in cross section, four loads and a redundant support. The solution will show the steps to calculate the deflection along the shaft's length.

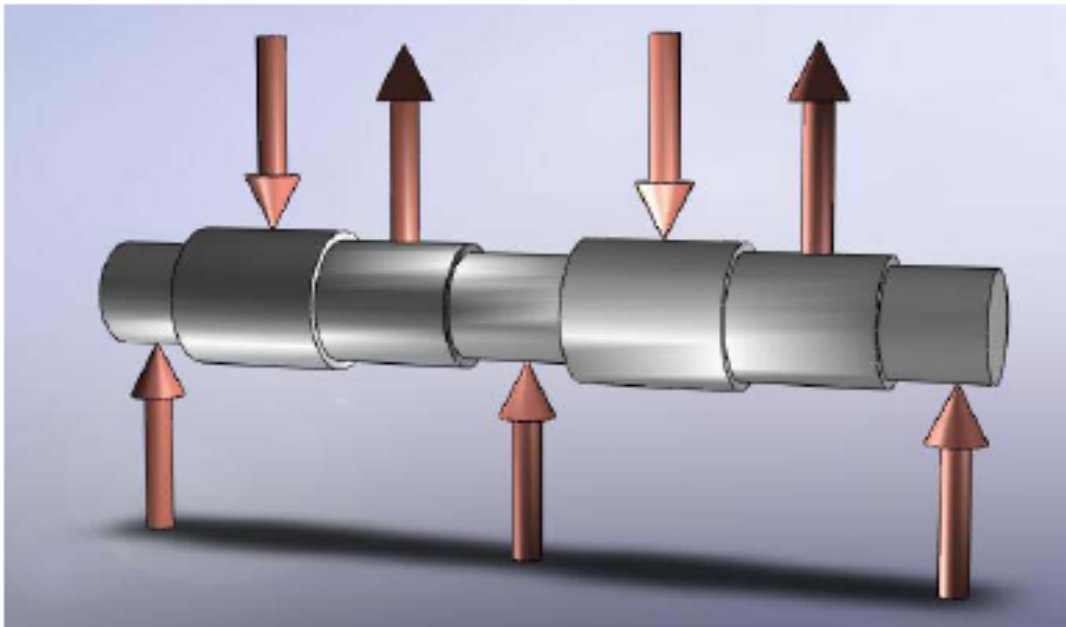


Figure 1. Rendered image of the Hopkins shaft [14].

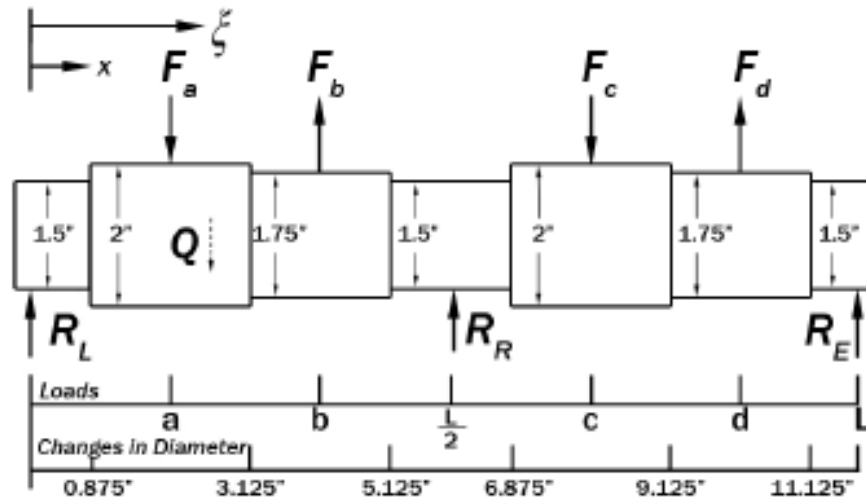


Figure 2. FBD of Hopkins Shaft with Applied Loads and Moments, and with Dummy-Load,  $Q$  for solution of statics.

Step 1: Draw FBD and solve statics

A dummy,  $Q$ , is applied at an arbitrary distance,  $\xi$ , from the origin, in the negative direction as shown (Figure 2).

To solve for reaction forces, the equilibrium equations ( $\sum M=0$ ;  $\sum F=0$ ) are used. First summing moments about the left reaction,

$$-F_a(a) + F_b(b) + R_R\left(\frac{L}{2}\right) - F_c(c) + F_d(d) + R_E L - Q\xi = 0 \quad (3)$$

$$R_L - F_a + F_b + R_R - F_c + F_d + R_E - Q = 0 \quad (4)$$

Using (3) and (4), we solve explicitly for the support reactions as follows:

$$R_R = \frac{2[F_a(a) - F_b(b) + F_c(c) - F_d(d) - R_E L + Q\xi]}{L} \quad (5)$$

$$R_L = F_a - F_b + F_c - F_d - R_R - R_E + Q \quad (6)$$

Before proceeding to the Moment equation, we want to define the Heaviside function as:

$$H(a, b) = \begin{cases} 0 & \text{if } a \leq b \\ 1 & \text{if } a > b \end{cases} \quad (7)$$

The Heaviside function,  $H(x, \xi)$ , serves as a "switch" to turn "on" or turn "off" individual terms in the moment equation.

Step 2: Write the moment equation  $M(x, \xi)$  for the entire shaft using the Heaviside function.

$$M(x) = R_1 x - F_a(x-a)H(x, a) + F_b(x-b)H(x, b) + R_x \left(x - \frac{L}{2}\right) H\left(x, \frac{L}{2}\right) - F_c(x-c)H(x, c) + F_d(x-d)H(x, d) - Q(x-\xi)H(x, \xi) \quad (8)$$

Step 3: Substitute in the reaction forces found from equations (5) and (6) into equation (8) above, then take the partial derivative with respect to the dummy load,  $Q$ , obtaining (9) below.

$$\frac{\partial M}{\partial Q} = \left(1 + \frac{x\xi}{L}\right) x + \frac{2\xi}{L} \left(x - \frac{L}{2}\right) H\left(x, \frac{L}{2}\right) - (x - \xi)H(x, \xi) \quad (9)$$

Step 4: Set  $Q=0$  and write  $M(x, \xi)$  for  $Q=0$ . The result is shown in EQ (10).

$$M(x) = R_1 x - F_a(x-a)H(x, a) + F_b(x-b)H(x, b) + R_x \left(x - \frac{L}{2}\right) H\left(x, \frac{L}{2}\right) - F_c(x-c)H(x, c) + F_d(x-d)H(x, d) \quad (10)$$

Where

$$R_1 = F_a - F_b + F_c - F_d - R_x - R_x$$

$$R_x = \frac{2[F_a(a) - F_b(b) + F_c(c) - F_d(d) - R_x L]}{L}$$

Step 5: Substitute in the expressions from Equations (9) and (10) into (2) repeated below and solve parametrically for various values of  $\xi$  (each  $\xi$  corresponds to a  $\delta_c$ ).

$$\delta_c = \frac{\partial U}{\partial P} = \int_0^L \left(\frac{M}{EI}\right) \left(\frac{\partial M}{\partial Q}\right) dx \quad (2)$$

### **Solution Process and Validation of Numerical Solution**

Once the governing equations were written in generalized form (Eqns. 9, 10, and 2), we wanted to determine a way to validate them. We chose to use these equations to solve a simpler problem that we could check. We simplified the shaft to have a constant diameter of 1.5 inches, simply

supported at each end, and with the same four vertical external loads applied. (Figure 3).

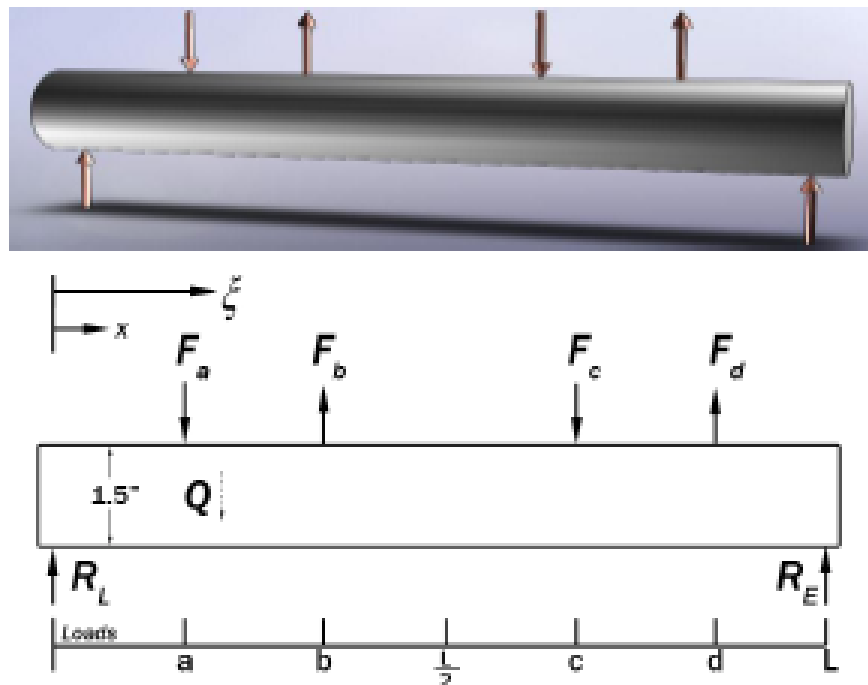


Figure 3. Image of uniform diameter shaft used to validate equation solver solution and for comparison to deflection by superposition approach.

The variable values used to complete the deflection calculation are provided in Table 1 (length dimensions and loads were kept the same as in the original shaft; only the middle support was removed and the diameter set to a constant value of 1.5 inch).

We conducted a deflection analysis at the midpoint ( $L/2$ ) using the principles of superposition. Each of the four applied loads ( $F_a$ ,  $F_b$ ,  $F_c$ , and  $F_d$ ) contributes to the deflection at the midpoint of the shaft ( $L/2$ ), so a deflection calculation was done to determine the contribution of each load to the deflection at the midpoint of the shaft (equations and values are summarized in Table 2 below). We used the variable values listed in Table 1 to calculate the deflection values listed in Table 2. Then the four deflection contributions were totaled.

Table 1  
Variables for use with superposition

Variable	Value
a	2 in
b	4.125 in
c	8 in
d	10.125 in
$F_a$	3000 lb
$F_b$	2100 lb
$F_c$	3000 lb
$F_d$	2100 lb
L	12 in
$L/2$	6 in
E	$30 \times 10^6$ psi
I	0.2485 in <sup>4</sup>
Diameter	1.5 in

Table 2  
Calculation of Deflection Using Superposition

Deflection at $\frac{L}{2}$ resulting from load at $F_i$	Numerical value (inch)
$\delta_{m,F_a} = \frac{F_a a(L - \frac{L}{2})}{6EI L} (\frac{L}{2})^2 + a^2 - 2L\frac{L}{2}$	-0.006975
$\delta_{m,F_b} = \frac{F_b b(L - \frac{L}{2})}{6EI L} (\frac{L}{2})^2 + b^2 - 2L\frac{L}{2}$	0.00881
$\delta_{m,F_c} = \frac{F_c (L - c)\frac{L}{2}}{6EI L} (\frac{L}{2})^2 + (L - c)^2 - L^2$	-0.01234
$\delta_{m,F_d} = \frac{F_d (L - d)\frac{L}{2}}{6EI L} (\frac{L}{2})^2 + (L - d)^2 - L^2$	0.004599
$\delta_{\text{superposition}} = \delta_{m,F_a} + \delta_{m,F_b} + \delta_{m,F_c} + \delta_{m,F_d}$	-0.005907

Using the alternate approach of Castigliano's Second Theorem augmented by the Heaviside step function, we input the governing equations developed in the previous section detailed above [Eqs. (2), (9) and (10)] into equation solving software and calculated the deflection of the entire shaft, resulting in the deflection curve shown in Figure 4.

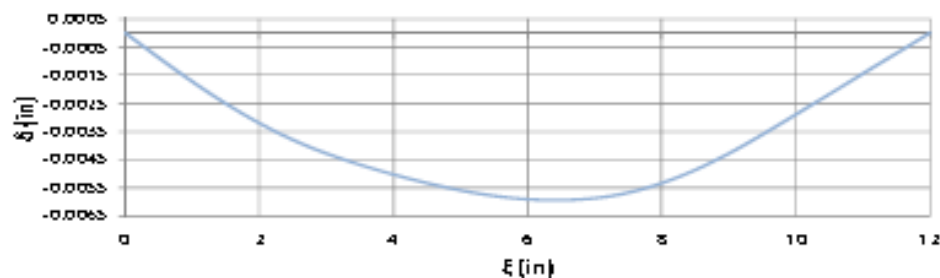


Figure 4. Deflection of a simply-supported uniform-diameter (1.5 in.) shaft with four external loads. Castigliano's Theorem and Heaviside function governing equations were used. Deflection at the point of interest is -0.005907 inches.

Then we compared the midpoint of the shaft and found the superposition deflection was matched exactly by the alternate Castigliano-Heaviside approach (Table 3). This gave us confidence that we could proceed to determine the magnitude of the center-support necessary to bring the midpoint deflection back to zero.

Table 3  
Comparison of midpoint deflection using Mechanics of Materials Superposition approach and alternative Castigliano's Theorem with Heaviside approach

Superposition	Castigliano-Heaviside
-0.005907inches	-0.005907inches

We used the Mechanics of Materials tables and found the support value required to be  $R_a=1223.2$  lb. Then we entered this value as a known input value in our Castigliano-Heaviside model and calculated the deflection for the entire shaft length (shown in Figure 5). The calculated midpoint deflection was verified in detailed numerical output and found to be essentially equal zero ( $\delta_{L/2}=4.7 \times 10^{-8}$ ), as expected.



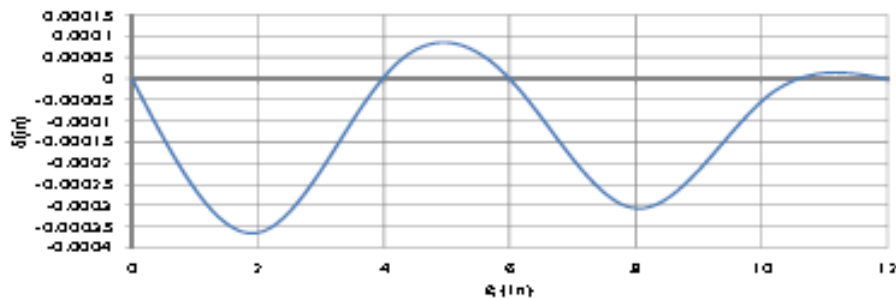


Figure 5. Deflection of a uniform-diameter shaft with redundant support specified ( $R_0=1223.2$  lb) such that at  $x=6$  inches the deflection is zero.

### Solution for the Statically Indeterminate and Stepped Shaft

With the exercise completed using the uniform diameter shaft to solve for deflection along the entire length and the redundant support force needed, we turned our attention to solving for the deflection of the statically indeterminate shaft with six changes in the shaft diameter. To do so, we defined a function to determine the shaft diameter for any value of  $x$ .

Each equation solver specific functions are needed to define the diameter changes needed for this shaft. Shown in Figure 6 are two examples. On the left is the TKSolver™ user-defined function “dia” which consists of a table of domain and range values to “look up” and find the needed value for diameter. This function subroutine is called thousands of times during the execution of the shaft deflection analysis TKSolver™ file. On the right of Figure 6, a user-defined function “dia(x)” in EES<sup>®</sup> exploits a series of if-then-else statements which act as a sieve to determine the diameter needed. Other equation-solving programs have different requirements [15].

Once the diameter function was included, it became a rather simple and fast exercise to conduct the analysis using the modified input file and the original governing equations developed for the uniform diameter case. Once again, the middle support was set to zero and a deflection curve was calculated (Figure 7) for the entire shaft.

Element	Domain	Range
1	0	1.5
2	0.875	2
3	3.125	1.75
4	5.125	1.5
5	6.875	2
6	9.125	1.75
7	11.125	1.5
8	12	1.5

```

*Define the diameter as a function of x
function dia(x)
  if x<0.875 then dia=1.5 else
    if x<3.125 then dia=2 else
      if x<5.125 then dia=1.75 else
        if x<6.875 then dia=1.5 else
          if x<9.125 then dia=2 else
            if x<11.125 then dia=1.75
              else dia=1.5
    end if;
  end if;
end if;
end if;
end if;
end if;
end if;
end
  
```

Figure 6. Look-up tables, determining diameter for any  $x$ .

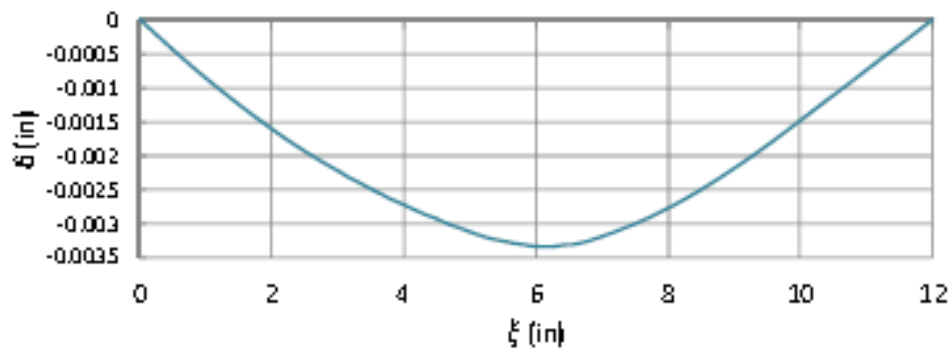


Figure 7. Deflection for stepped cross-section, center support removed.

This time, because of the multiple changes in shaft diameter, we could not use a straight-forward calculation to determine the center support value, so we used a guess-and-check approach by running a parametric study for a range of center support values. The center support value that resulted in the deflection closest to zero was found to be  $R_1=1072.18\text{lb}$ .

### Results and Comparisons

We present the final deflection (Figure 8) for the entire length of the indeterminate and stepped shaft shown above in Figure 1. The results compare very favorably, within five percent, of published values done by an experienced engineer [14] who literally “wrote the book [7]” on beam and shaft design and analysis.

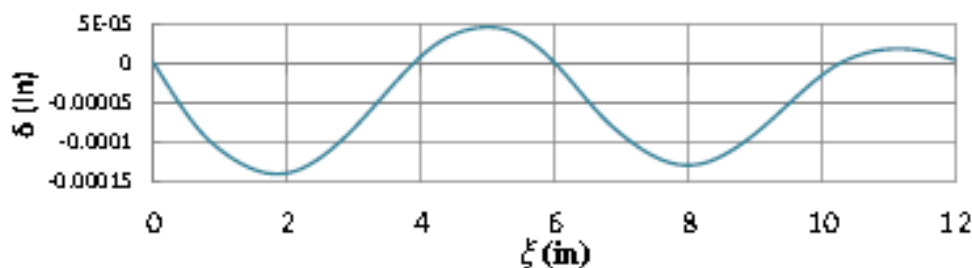


Figure 8. Final deflection for shaft with a stepped cross-section, center support determined.

### Conclusions and Future Work

Calculating deflection is one of the most difficult skills to learn in Mechanics of Materials. However, analysis and design of shafts requires the student to be proficient in the determination of deflection for cross-sections that are non-uniform and which may also involve indeterminate support. We have demonstrated, by way of example and explanation, how an alternative

approach can be readily combined with modern engineering tools to accomplish accurate deflection analysis for complex shaft geometry and indeterminate supports. We used fundamental theories of Castigliano's Second Theorem and the idea of Discontinuity Equations which were carried out by the use of the Heaviside Step Function to act as a "switch" for each term in the shaft moment equation. By carefully writing correct governing equations and then using a modern equation solver, the analyst can save time on calculations and spend additional time contemplating the meaning and usefulness of the results. We believe this alternative approach could be successfully introduced and mastered at the undergraduate Mechanics of Materials level as the primary method available for deflection determination.

## References

1. Ju, F.D. 1971. "On the constraints for Castigliano's theorem," *Journal of the Franklin Institute*, Volume 292, No. 4, Pages 257-264.
2. Odom, Edwin and C.J. Egehoff, "Stepping Through Shaft Deflection Calculations," *Machine Design*, pp. 58-60, June 10, 2010. Available online at <http://machine-design.com/article/calculate-deflection-in-stepped-shafts-the-easy-way-0608>
3. Stroeder, Walter, "Beam Deflections," *Machine Design*, p. 85-90, January 1947.
4. Cowie, Alexander, "A tabular method for Calculating Deflections of Stepped and Tapered Shafts," *Machine Design*, p. 111-118, August 9, 1956.
5. Margolin, Lawrence L., "Calculating Deflections in Variable- Section Beams," *Machine Design*, p. 173-181, March 16, 1961.
6. Halasz, Sandor T., "Minic alcs find Stepped- Shaft Deflections," *Machine Design*, p. 78-82, June 27, 1974.
7. Hopkins, Bruce R., *Design Analysis of Shafts and Beams*, Mc Graw-Hill Book Company, New York, NY, 1970.
8. Collins, Jack A., Henry Busby and George Staab, *Mechanical Design of Machine Elements and Machines*, 2<sup>nd</sup> Edition, John Wiley & Sons, Hoboken, NJ, 2010.
9. Spotts, Merihyl F., Terry E. Shoup and Lee E. Homberger, *Design of Machine Elements*, 8<sup>th</sup> Edition, Pearson Prentice Hall, Upper Saddle River, NJ, 2003.
10. Mott, Robert L., *Machine Elements in Mechanical Design*, 4<sup>th</sup> Edition, Pearson Prentice Hall, Upper Saddle River, NJ, 2004.
11. Irvinall, Robert C. and Kurt M. Marshek, *Fundamentals of Machine Component Design*, 4<sup>th</sup> Edition, John Wiley and Sons, Inc, Hoboken, NJ, 2006.
12. Budynas, Richard G. and J. Keith Nisbett, *Shigley's Mechanical Engineering Design*, 8<sup>th</sup> Edition, Mc Graw-Hill, New York, NY, 2008.
13. Odom, E.M. and C.J. Egehoff, "Teaching Deflection of Stepped Shafts: Castigliano's Theorem, Dummy Loads, Heaviside Step Functions and Numerical Integration," *Proceedings of the Frontiers in Education Conference*, Rapid City, SD, October 12-15, 2011. Available online at <http://fie-conference.org/fie2011/papers/1541.pdf>
14. Hopkins, R. Bruce, "Calculating deflections in Stepped Shafts and Nonuniform Beams," *Machine Design*, p. 159-164, July 6, 1961.
15. Egehoff, C.J., E.M. Odom and B. Wiest, "Application of Modern Engineering Tools in the Analysis of the Stepped Shaft: Teaching a Structured Problem-Solving Approach Using Energy Techniques," *Proceedings of the Frontiers in Education Conference*, Washington, D.C., October 2010. Available online at <http://fie-conference.org/fie2010/papers/1153.pdf>

## **Conflicting Models of the Product Life Cycle: Worldviews and the Design of Technology**

RICHARD DEVON

Professor of Engineering Design, Engineering Design Program, SEDTAPP, Penn State University. He was Interim Director of the Science, Technology, and Society Program for two years, Director of the PA Space Grant Consortium, and founding Director of the Engineering Design Program. He teaches design, and researches and publishes on design education with current interests in Cloud computing platforms, global design, and rapid prototyping.

RICHARD SCHUHMANN

Professor Rick Schuhmann has been a faculty member at Penn State since 1998 and is currently the Walter L. Robb Director of Engineering Leadership Development in the College of Engineering. Dr. Schuhmann's industry experience includes offshore geophysical exploration and onshore work as an environmental consultant. His teaching reaches across the engineering, entrepreneurship and leadership curricula, with a focus on sustainability & global collaboration.

# **Conflicting Models of the Product Life Cycle: Worldviews and the Design of Technology**

## **Abstract**

In teaching engineering design we often use an ecosystem perspective on the product life cycle of extraction through disposal. Yet other views of the product life cycle exist, such as the business model, the diffusion model, and various user models. The business model is very widely held and more influential in practice than the ecosystem model. While they are all very different models, all but one assumes the general model that products come and go. This article brings together the various models of the product life cycle in one reading, which might encourage resolution of the deep conflicts among these perspectives as well as be helpful to students studying design. We end by suggesting a meta-model of the product life cycle that would allow designers to see all the perspectives simultaneously and even to add new ones.

This review should improve a student's ability to communicate effectively with others about the development and operation of technology, and also to understand how, and why, conflicts must inevitably arise in the design of technology, even without the political differences that occur using any given model of the PLC. The intent is to create a reading that offers students breadth in understanding how technology functions in society and how, why, and for whom we design, and with what consequences.

## **Introduction**

In this article we explore different models of the product life cycle (PLC), each of which is derived from a different world view. Students of engineering design should understand these different models of the product life cycle, what each can teach us about design and about the different world views of different stakeholders. This understanding should improve student's ability to communicate effectively with others about the development and operation of technology. It should also help them understand how, and why, conflicts must inevitably arise in the design of technology. The intent is to create a reading that offers students breadth in understanding how technology functions in society and how, why, and for whom we design, and with what consequences. We understand that we are only lightly covering a very large content area, but we hope that we identify many pathways for readers to follow while conveying the intent of the paper.

## **The General Model of a Product Life Cycle**

Each model of the PLC describes reality with varying degrees of veracity and completeness, but each model differs from the others because of the different world views (mindsets) of the proponents more than the different degrees of veracity or completeness of the model. They tend to focus on different characteristics of PLCs, which makes dialog difficult. However, we assume at outset that product life cycles all *really* have the following characteristics, regardless of the world view taken.

1. Products come and go.
2. PLCs create Flow-Throughs (FTs) of energy and materials.

3. The Total Flow-Through (TFT) of PLCs transforms society and transforms the environment in ways that may or may not be sustainable, and that may or may not create a better world.
4. The TFT has major impacts on things such as productivity, human health and happiness, resource depletion, environmental impacts, species loss, ecosystem resilience, and the generation and distribution of toxins. Crises in any of these can lead to a collapse of the general model.
5. Most PLCs are currently supported by global supply chains, and, as such, have weakened chains of visibility and accountability. However, localized, autonomous PLCs do represent an alternative to the global interdependent model and thus raise the idea of a second general PLC model: a distributed, largely unlinked, autonomous, localized, *production-use-disposal* model. And two models raise the possibility of a hybrid model that might plausibly describe reality most accurately and provide a metric for where we are in the continuum between the two.

### **Commentary on the General Model**

Technology is human behavior that always transforms society and the environment, sometimes to the extent of changing what it means to be human and the fundamental nature of the ecosystem. Human spaces are now dominated by the sciences of the artificial (design), and the technological density of our lives steadily increases with ever increasing numbers of successes, failures, and learning curves in our culture. Design is the cornerstone of technology. Design is how we solve our problems, fulfill our needs, shape our world, change the future, and create new problems and new opportunities. From extraction to disposal in the life cycle of a product, the design process is where we make important decisions; the decisions that determine most of the final product cost, and the decisions that determine most of the ethical costs and benefits. Everything is designed but not everything is designed well, and the sheer volume has now become critical.

According to a recent analysis in the *Economist*,<sup>1</sup> most of the economic activity in human history has taken place in the 19th and 20th centuries. The world population has grown 10-fold since 1811 and when the growth of per capita gross domestic product (GDP) is factored in, the results are even more remarkable. “Over 23% of all the goods and services made since 1AD were produced from 2001 to 2010, ...” That is, almost a fourth of all the goods and services produced in the last 2,000 years were produced in the last 10 years. It is hard to believe that this exponential growth has a very long future, even if it is more exaggerated than growth rates in the TFT of energy and materials.

A recent dichotomy, which vividly depicts an inter-model conflict, is the economic belief in salvation through shopping contrasted with the possibility of the “end of shopping.” One pole of this dichotomy is seen in a Washington Post article by Robert Samuelson in 2008.<sup>2</sup> Samuelson’s article was framed in a downturn in the business cycle. He noted that “consumer spending equaled 70 percent of [US] GDP” and is one of the main drivers of the global economy. Samuelson called for the return to shopping by confident consumers as soon as possible. In contrast, the 2011 book by environmental activist Paul Gilding sees a fundamental end to shopping and the collapse in the general product life cycle model as almost inevitable because of global climate change.<sup>3</sup>

Gilding’s view is that we need to seek more happiness, not more products and services. This can be pursued in some of the models we review below such as the user views, particularly in

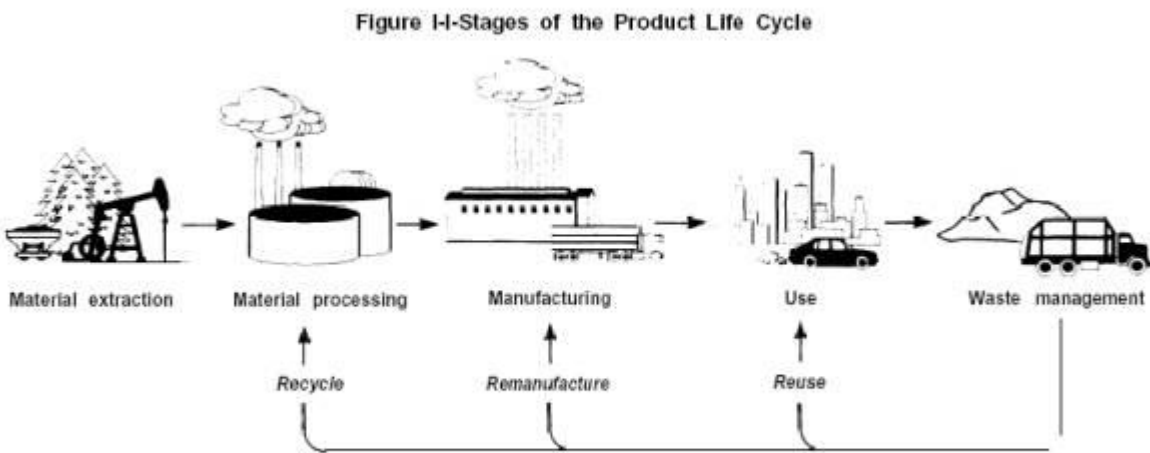
affective design. In Buddhist terms, Gilding’s position is that we need to pursue the Gross National Happiness Factor<sup>4</sup> (former Bhutan King Jigme Singye Wangchuck) rather than the GDP or Gross National Product (GNP).<sup>5</sup> The idealism in Gilding may be the idea that we can change by design rather than by catastrophe; that we are capable of proactive evolution. He spends most of his book trying to persuade us to be rational and he is not convincing. But the “end of shopping” is certainly a teachable moment.

All technologies have life cycles, even those intended for permanence, but how these life cycles are described varies considerably. The differences among models of the PLC is one way of capturing how very differently people may view the same product. Products mean profits or jobs to some, pollution or unacceptable injury and death rates to others, bring great utility or pleasure, or are an intrusive and unwelcome presence in a household, community or nation.

The benefit of this analysis is to explore how what we view as design knowledge is not only variable in very significant ways but how those ways reflect different world views embedded in different social formations and different personalities. Students can then readily see how design is, as Herbert Simon portrayed it, an essentially normative process for achieving human ends using the sciences of the artificial.<sup>6</sup> By incorporating the most popular models in one review, the approach should be open to most, and almost everyone will recognize and identify with one or more of the models. This inclusiveness is central to what we hope to achieve.

A common way to depict the product life cycle in design is shown in Figure 1-1 from *Green Products in Design* (1992).<sup>7</sup>

4 • *Green Products by Design: Choices for a Cleaner Environment*



Environmental impacts occur at all stages of a product’s life cycle. Design can be employed to reduce these impacts by changing the amount and type of materials used in the product, by creating more efficient manufacturing operations, by reducing the energy and materials consumed during use, and by improving recovery of energy and materials during waste management.

SOURCE: Adapted from D. Navin chandra, The Robotics Institute, Carnegie Mellon University, personal communication, March 1992.

However, several other views of the product life cycle exist, such as the business model and the diffusion model, the former being even more influential in how technology is practiced than the ecosystem model. We will explore these other views, and then we will suggest a meta-model of

the product life cycle that allows designers to see all the perspectives simultaneously and even to add new ones.

## Models of the PLC: A Summary

### Outline

1. The ecosystem view
2. The social transformation view
3. Institutional views: business and government
4. The prestige model of permanent technology
5. The user views
  - a. The utility model
  - b. The affective model
6. The rational (ethical) model

### 1. The Ecosystem View: The Planetary Perspective

The conventional eco-cycle model of the PLC is shown in Figure 1-1. Traditionally, this PLC assessment is focused on the ecosystem, its resources, and its sinks. This model is used to identify resource limits (eg, peak oil, the peak ocean fish catch), species loss, pollution loads, and other systemic perturbations (eg, stratospheric ozone depletion, global climate change, antibiotic resistant bacteria, and toxic releases). The idea of sustainability has become the organizing principle for ecosystem-centric design (ecodesign).<sup>8</sup>

A planetary perspective began to emerge out of the environmental movement marked by classic books such as Aldo Leopold's *A Sand County Almanac* (1949)<sup>9</sup> and Rachel Carson's *Silent Spring* (1962).<sup>10</sup> The post-WWII industrial and chemical boom led to considerable environmental damage. This triggered a greater awareness and concern about the environment and led to a host of statutes aimed at managing technology that continues today.<sup>11</sup> January 1, 1970 saw the passage of the U.S. National Environmental Policy Act (NEPA)<sup>12</sup> written to "...encourage productive and enjoyable harmony between man[sic] and his environment." A new field of study arose in civil engineering - environmental engineering. Beginning with a focus on how to manage and deal with wastes after their production, environmental engineering now deals more completely with environmental risk and safety by also developing new production processes that reduce or eliminate certain waste products. So, environmental objectives moved upstream into the design process, hence green design, which, in turn, applies to all engineering practice. One of the first publications to use the term was the Office of Technology Assessment's *Green Products by Design* (1992).<sup>13</sup> "Green design means practicing engineering with the inclusion of natural systems, both as a model and as a fundamental consideration, for the improvement of the quality of all life. Essential to the idea of green design was moving environmental considerations from upstream product manufacturing to the product design process."<sup>14</sup> Leading exponents of this view include Papanek, Graedel and Allenby, McDonough and Braungart, and Leonard.<sup>15</sup>

### 2. Social Transformation View: Sociocultural models



Technology transforms the environment and society; always. Eco-transformations are considered under the planetary/ecosystem perspective above. Here we will identify several worldviews of the PLC from social and cultural perspectives.

a) Technological innovation as the prime economic driver: This is the theory that innovation (creative destruction), and the creation of ever new PLCs, is central to economic growth (Schumpeter<sup>16</sup>). Progress in technology does account for a large part of economic growth, but it is not a new idea, not even when Schumpeter was writing about it. Innovation to create new PLCs to satisfy venture capitalists was a driver for the first European settlers in North America in the early 1600s.<sup>17</sup> It is embedded in the Constitution of the United States.<sup>18</sup> It is still a very widely and very strongly held belief and a perennial rationale for the benefits, and the costs, of modern technology. It has been a staple of policy from Jamestown until today.

“We need to out-innovate, out-educate, and out-build the rest of the world,” Obama said before a joint session of Congress [State of the Union, 2011]. “We have to make America the best place on earth to do business.” If there was a central theme to the president’s remarks, it was innovation. He called for more investment in education, research, science and clean energy.’ Forbes<sup>19</sup>

Unfortunately, the ambition level of immigrants, always a driver of growth and innovation in the United States, has been severely constrained by policy in recent decades where the untrained and illegal immigrants are favored over the educated and legal immigrants who start new companies at twice the rate of the native born.<sup>20</sup>

b) Technology as the determinant of culture: Technological determinists (Ellul,<sup>21</sup> Drucker,<sup>22</sup> White<sup>23</sup>) like to describe eras in terms of the technologies and the product life cycles that shaped them; from the agricultural technologies that created surpluses and then trade, cities, governments, armies, and religions in ancient Mesopotamia (Drucker, *op cit*), to air conditioning promoting migration southward in the United States. In this model, it is culture that is directly shaped by technology and product life cycles are often viewed in design from the perspective of consumers, or victims in the case of product liability and recalls. Designers focus on customer needs, but they can, too, use scenario design and anticipate human futures resulting from current design ideas.

c) Technology transport phenomena: There are models of the ways technologies are actually adopted and diffused. In these models, technology, like a contagion, can be transported and incorporated via various pathways. For example, the diffusion/adoption model of *innovators*, *early adopters*, *early majority*, *late majority*, and *laggards* is based on the work of Everett Rogers.<sup>24</sup> Malcolm Gladwell’s work in *The Tipping Point*<sup>25</sup> also falls into this category, where he examines how products go from relative oblivion to becoming a market leader via facilitated transport by various human actors. Diffusion is a holy grail for many types of design, and successes range from the Qwerty keyboard to Coke and the iPhone. Laggards in other countries may feel it is a form of imperialism, hence the banning of Coke in India, or the charge of monopolistic practices as has been frequently charged against Microsoft in Europe.

d) Society as the shaper of technology: Social constructionists view technology as arising from the culture within which it is born.<sup>26</sup> The product life cycle is viewed in terms of who created the technologies and why. In 1969, George Daniels famously inverted the thesis that technology shapes society by showing how often it was just the opposite that took place, such as the cotton gin being invented to deal with a surplus of cotton rather than creating such a surplus.<sup>27</sup>

Lynn White, who argued a determinist thesis that the plough and the stirrup shaped medieval Europe (op cit.), also argued ([Wikipedia](#)) a constructionist thesis that Judeo-Christian theology is fundamentally exploitative of the natural world because:

1. The Bible asserts man's dominion over nature and establishes a trend of anthropocentrism.
2. Christianity makes a distinction between man (formed in God's image) and the rest of creation, which has no "soul" or "reason" and is thus inferior.<sup>28</sup>

Most engineers hold this constructionist view, since they are part of the social construction processes. This is especially true in design. Design educators have embraced this in design education by adopting a social process model of design in recent decades.

### **3. Institutional Views: Business & Government.**

The standard business model of the product life cycle is Introduction, Growth, Maturation, Saturation and Decline based on the supply and demand and the corporate return on the investment.<sup>29</sup> There are important technical PLC models within this industrial model such as Product Lifecycle Management (PLM).<sup>30</sup> which maintains the knowledge base for a product and is usually integrated in high-end Computer Aided Design (CAD) systems.

Products have a birth, a life, and a death, and they are financed and marketed with this in mind. Product sales and profits start at a low level, then rise until market saturation occurs for the product type (and market share stabilizes for a particular product). This is followed by a decline to a low level, and then a phase out, or sell off. Profits for a company's product often collapse at the end of one or more patents (now 20 years in NAFTA countries). Philip Kotler,<sup>31</sup> paraphrased and expanded below, breaks the product life cycle (PLC) into five distinct phases:

*i) Product development.* This is the phase when a company looks for a new product. New products do not have to be disruptive technologies, although these may have bigger profit margins initially (like the video-cassette recorder, compact disc, cell phone, or smartphone). They may be merely additions to existing product lines (the first cigarette with a filter tip, for instance) or improvements to existing products (a new whiter-than-white washing powder or toothpaste, or more legroom and better mileage in this year's model of a car). In fact, such redesigns make up the bulk of all design activity and serve to keep the capital investment in the PLC going as long as possible until, like the disposable camera faced with mobile phone cameras, they just collapse to niche markets or oblivion.

*ii) Introduction.* The product's costs rise further as the expense of advertising and marketing any new product begins to take its toll; the introductory push needs to be intense at the onset. But the

probability of a strong market response must be determined far earlier during the front end engineering design (FEED).

*iii) Growth.* As the product begins to be accepted by the market, the company starts to recoup the costs of the first two phases. The break-even-point is when the revenues match the current expenditures. As revenues exceed expenditures they generate a return on the investment (ROI) that has been made in the PLC to date.

*iv) Maturity.* By now the product is widely accepted and growth slows down as market saturation occurs even overseas. A successful product in this phase will come under pressure from competitors. The producer will have to start spending again in order to defend the product's market position. The Intellectual Property (IP) rights that protect the product come under fire in what is usually referred to as "patent wars." These wars are fought between those who seek to gain income from the PLCs of others, and those who seek to protect their own PLCs. Most companies engage in both and it is a complex scene that only occurs when there is a great deal of money at stake. For example, in 2011 Apple and Samsung are going head to head in the smartphone and tablet markets and both suing each other. Remarkably, Samsung makes 25% of Apple's iPhone, in addition to its own products and makes very sensitive decisions about how to deploy its resources. In fact, Samsung manufactures all of the Apple A4 and A5 package on package (PoP) system on a chip (SoC) contained within iPad, iPhone, and iTouch.<sup>32</sup>

*v) Decline.* Ultimately a company will no longer be able to fend off the competition with acceptable profit margins, or a change in consumer tastes or lifestyle will render the product redundant as disruptive technologies that create new markets with new ways of doing things sweep the old ones aside. For example, by the end of the 1990s, cell-phones had largely replaced land lines in Finland, and many other countries followed. All stages may be played out globally and some PLCs may linger on in developing economies for many years. This can happen for products that get banned in advanced industrial societies where laws are stricter. One example is DDT, banned for agricultural use in the US in 1974, yet not banned worldwide for agricultural use by the Stockholm convention in 2004. Today DDT is still manufactured in India and China, albeit ostensibly only for vector control and not agriculture.<sup>33</sup> And the end of a patent, 20 years under NAFTA, usually triggers intense competition and lower prices as in generic drugs.

Products of fashion, by definition, have a shorter life cycle, and they thus have a much shorter time in which to reap their reward. A distinction is sometimes made between fashion items, such as clothing and accessories, and pure fads, such as the notorious pet rocks. It is not always immediately obvious into which of these two categories a product falls. When they were first introduced in the early 1980s, in-line skates seemed as if they might be a brief fad. But 25 years later they were still selling strongly, firmly set in the mature stage of their life cycle. They may not be destined for the life cycle of the corn flake, but they have already outlived many seemingly more permanent products. Only the future can decide the longevity of a product, so in hindsight we marvel at the QWERTY keyboard, the dial phone, and the ethernet protocol. And proponents of sustainable design should seek clues that explain their successful longevity.

Government views of PLCs occur in different ways in policy, procurement, design, realization, and in use. Their PLCs typically lag the market in introduction and in abandonment, with the exceptions of technologies for defense and prestige, and they usually suffer from elevated costs.

Both business and government approaches to the PLC are that of social construction and government policies and corporate strategies reflect this. However, statutes that manage the impacts of PLCs, such as clean water and clean air acts, have grown exponentially since the 1970s.<sup>34</sup> As a result, corporations try to anticipate the trajectory of regulations on technology through such tools as scenario planning, eg, Shell,<sup>35</sup> and through lobbying to get the regulations they want and, on occasion, write.

Ulrich and Eppinger's *Product Design and Development*, exemplifies the business model of a PLC in design education.<sup>36</sup> It has been widely used in engineering design education since the first edition in 2000.

#### **4. Prestige Perspective**

This is the category, very important in history, where a conventional PLC may not be envisioned. Rather, a product is created for permanent use, and such products are often designed to be singular. The reason is usually prestige by governments, corporations, and individuals. Examples include many buildings such as the Eiffel Tower, the Burj Khalifa, and the Empire State Building. They also include nationally promoted technologies like those of the US space program, the Three Gorges Dam in China, the supersonic Concorde or high speed rail in France. Some of these induce crippling debts. For example, the Burj Khalifa was called the Burj Dubai until, at the point of completion in 2010, Dubai ran out of money in a global economic downturn. It turned for help to the neighboring oil-rich emirate of Abu Dhabi and its emir, Khalifa, and the symbol of the prestige changed.<sup>37</sup>

Prestige also occurs in the individual models assuming a conventional PLC where desire for prestige in fashion has triggered criminal behavior, and in the business model where prestige drives up-scale marketing and even mass marketing using prestigious icons. The effect of prestige on product selection is seen across age groups. In a study of clothing choice among adolescents, in general those with the highest self esteem most valued utilitarian design elements while susceptibility to interpersonal influence (i.e. peer pressure) was associated with the importance the adolescent placed on prestige related display elements<sup>38</sup> The message sent in fashion is the point. It is worth noting that the word prestige derives from the Latin word "praestigium" meaning "delusion, illusion, and even to trick."<sup>39</sup>

Corporate visual identity (CVI) drives corporations to regularly purchase products to enhance their prestige.<sup>40</sup> For example, corporate offices are built symbolically robust and tall (e.g. Sears Tower, Chrysler Building) or surrounded by highly engineered and groomed landscaping in order to project an identity message of prestige. The engineering and costs embodied within these design choices are clearly in excess of purely utilitarian alternatives. Corporations may also purchase prestige products unrelated to their primary business, such as sports arenas to enhance their CVI. These arenas are often purchased with a quasi-permanent time horizon; some are less permanent than others (e.g. Enron Field *aka* Minute Maid Park).

### ***Non-cyclical Quasi-permanent Products***

While prestige products defy utilitarianism, non-cyclical quasi-permanent products defy consumerism. These products are often designed and built with little thought to a subsequent replacement model. Products such as dams and hydroelectric power plants (e.g. Hoover Dam), bridges (e.g. Golden gate, Brooklyn), and potable water treatment plants (e.g. 100 year old plants still in operation in the United States) are all large scale civil engineering examples of quasi-permanent engineering design solutions. These products are designed for maintenance, not replacement, their permanence reflective of the importance of their function and the large upfront cost of production. And they are not always maintained well as service loads increase. Bridges are aging everywhere, often with both a deteriorating structure and increased loads. But even if severely damaged or destroyed, prestige products are very likely to be rebuilt as was.

Quasi-permanence is not always achieved. The Maginot line, built on the heels of the Franco-Prussian and First World wars was designed as a permanent solution to the German problem, conceptual flaws in its design led to its premature demise. Conventional weapons and military supplies that are kept on hand in the event of a conflict are often warehoused beyond their intended lifespan; troops sent to fight in the early days of the Korean conflict did so with surplus WWII weapons and troops sent to Vietnam did so with those from the Korean conflict. Modern examples of quasi-permanent military investments exist in the form of nuclear weapons; products designed and built for their long term psychological utility instead of applied use and often retained in excess of their intended 25 year lifetime. The average stockpiled US nuclear weapon is 19 years with some dating from the 1970s and the US has not produced a nuclear weapon in over a decade.<sup>41</sup> And shifts from war to peace has left hundreds of thousands of land mines in ground trafficked by men women and children.<sup>42</sup>

Buildings, long treated as quasi permanent, have moved steadily towards PLC status. A recent report from the Vice-Minister of the Ministry of Housing and Urban-Rural Development in China contrasted the life expectancy of buildings there (25-30 years) with those in the US (74 years) and the UK (132 years),<sup>43</sup> but this masks much shorter life spans in some cities and housing developments.

In another venue one might also discuss products whose durability is far less or perhaps far more than claimed/ expected/intended.

### **5. User Views**

Customer needs have received a lot of attention in design education in the United States and is central to the business model of a very widely used design text.<sup>44</sup> In some views, more prevalent in Europe, it is the user rather than the customer who is the focus and these roles differ in important ways, not the least of which is that they are not always the same person. See IBM<sup>45</sup> and ISO.<sup>46</sup> Using either customers or users, the needs will be viewed below as a complex of material (utilitarian) and affective (emotional) needs. Usability cuts across this distinction, having aspects of both convenience and taste (eg touch screen or button keyboard on a smartphone).

We will summarize these two models of the product life cycle: i) Utility and material need: the return on the investment to the individual, and ii) Emotional bonding, and the subsets of social bonding through gift giving and risk management which are both affective and utilitarian.

***The utility model.*** In this view people make decisions based on owning something they need rather than want, and do so in a way that is best justified as an investment. Any given decision, such as a car needed for work may eventually be influenced by emotional bonding or enhanced prestige but it is first viewed as making a salary possible that may annually bring an income of several times the investment. A common modern calculus involves energy saving technology. How long does it take for the energy savings of a solar panel or a heat pump to pay for itself? In this world view a threshold is reached when there is a clear material incentive to engage in technologies that pay for themselves in a few years. This calculation can be influenced by government policies that provide tax incentives that, in effect, subsidize the adoption of the technology and considerably reduce the amortization period. For the federal government there may also be a material return to such an investment such as a reduced dependence on foreign oil and the need to fight expensive foreign wars to guarantee the supply chain. President Clinton ordered a significant governmental use of recycled paper in the mid 1990s.<sup>47</sup> This drove the price up to make that enterprise economically viable for the first time, and thus created a policy induced tipping point for the technology.

***The Affective Model.*** Affective design, designing for what people like in a design and how they feel about and bond with a design, has always been important. It has become more salient in design communities in recent decades with books such as those by Jordan, Norman, and Boatwright and Cagan.<sup>48</sup> The latter argue that emotion is the main driver of design choices and hence should be understood by those who design. The related field of industrial design that focuses on the aesthetics and usability of a product has also grown in influence, led by companies like Apple, and it has a large and active professional society, IDSA.<sup>49</sup>

The fashion industry runs on the ability to inculcate a desire to look cool, or at least appropriate, to one's social group. It is not really clear why a tipping point is reached that takes a product from the margins to center stage, but it is certainly not a rational mechanism (Gladwell, op cit). Emotion plays a major role in consumer products as people get considerable meaning in their lives from what they own and the way they feel about themselves. Serious crimes are committed for no better reason than an emotional attachment to a type of jeans, jacket, media player, bike, or car, perhaps because of the serious ridicule that permeates the consumer market. Emotional bonding has led to the new field of affective design, but the world it addresses and helps to create sometimes has as much pain in it as joy. The technological density of our lives continues to intensify. All technologies have problems and fail sooner or later, so the more technologies we have, the more problems we must have with technology. We also have more learning curves, manuals, and hot-lines to endure. All of which add stress to our lives. The fascination with the next technology we will buy helps distract us from the problems we have with those we already own and drives us to the next purchase. New products are now routinely and shamelessly sold with added costs for guarantees against failures, yet many new products are jettisoned while still working for a "better" model. Cell phones and smartphones barely last a year for the "early adopters." The global supply chains of several mineral components of mobile technologies, such

as conalt and cassiterite, have been linked to much carnage in the Congo that has most of the world supply of those minerals.<sup>50</sup>

Advertising is largely focused on the emotional drivers of consumer purchases and this experience is now informing design (Boatwright and Cagan, op.cit.). Typically it represents 2-3% of the GNP and in the US it was almost \$300 billion in 2007.<sup>51</sup> And advertising must continuously reinvent need as what they told consumers last year must inevitably be over-written by this year's messages. This may be unfortunate. People keep the things they like and some bonding to selected products may bring contentment, and prolonging product use is a mainstay of any program for sustainable technology since it reduces the number of product life cycles. Some people, some of the time, manage to achieve a fairly lengthy use stage with a product where the emotional bonding is sufficient to resist the messages of both advertising and perhaps close friends and relatives.

Affective design is, then, the Achilles heel of planned obsolescence, since, while instant attraction (and aversion to what we currently have) helps sales, if we design for sustained happiness and sustained ownership we will drive down the throughput of energy and materials. We need to define what we want without the help of advertising and its need to continuously redefine what it takes for us to be happy. The small voluntary simplicity movement is instructive in its rejection of most PLCs.<sup>52</sup> And it is here that the discussion of the Gross National Happiness factor needs to occur. How does the PLC model relate to quality of life issues such as technological density/rate of failures/stress. How does a product interact with us during its life cycle - does it enrich our lives or enslave us? Does it make our lives easier and as a result divorce us from experience?

**Subset: Social Bonding.** A variation in emotional bonding to a technology is in giving gifts that other people will like. Many gifts are given because the giver already likes the product, and the bond may or may not occur for the recipient and may lead to waste. When such gifts are accepted and used it becomes one of many ways in which the users of technology are different than the customers. This is of special significance in gift giving where much waste occurs because material need is less often met or the hoped for emotional connection never takes place - or worse, the result is an aversive reaction. However, gift giving is complex. In most cultures, influence, prestige, and honor are all major factors in gift giving and the nature of the gift economy varies enormously among cultures.<sup>53</sup>

**Subset: Risk Management.** This complex subject creates its own set of views about products. For many people safety means a safe home, a safe car, and health insurance. Using a TV means exposure to the relentless push of risk management products, from pharmaceutical advertising for health products to mitigate against maladies such as like "restless leg syndrome" and for beauty products that erase time; these products often seem cures for problems invented for the potion.

Yet a large part of the recreation industry celebrates risk and generates PLCs in high risk activities such as mountain bikes, hang gliders, bungy cords, and unpadded rugby shirts. A completely different genre of PLCs are found in personal security products, and yet another in

public institutions from local first responders to the forces overseen by the Department of Defense.

All of the above entail a fairly manifest set of expectations. The management of latent risk is much harder to do. Tens of thousands of chemicals have been released in the environment. Most are not tested for all uses and contexts since the uses and contexts are not fully predictable and it is very costly. Further, very little testing is done on interactive and cumulative effects, because that becomes impractical very quickly. This, in addition to the increasing difficulty of understanding modern technology, may be why while statistics indicate our lives are getting safer, people feel less safe.<sup>54</sup>

The unique model of PLCs in risk management is created by the insurance industry, which focuses on product liability and establishes dollar values for human lives, injuries, sicknesses, and the cost of losing a livelihood. Teaching design students about product liability and product recalls is a good way to include this perspective.

**6. The rational (ethical) models.** Rational/ethical reasoning is the category into which this article falls, and which has its own section since it purports to have general applicability - depending, crucially, on its diffusion beyond the authorship.

*Ethical Reasoning.* There is a very large body of literature representing the way individuals have reasoned directly or indirectly what makes a PLC good. Many of these focus on sustaining the ecosystem, or socio-ecosystem, and most others focus on what constitutes ethical technology and an ethical PLC without say the use of conflict minerals or child labor. Some have a more utopian cast such as the voluntary simplicity movement (op. cit.), and many communities from the Shakers to the Amish shape their use of PLCs. The major religions also have distinctive takes on technology as noted earlier about Christianity (White op. cit.).

It is unlikely that this sort of reasoned model can have any significant effect on PLC realities unless many other important people are influenced by the reasoning. Thus Gilding's book devotes most time to persuasion and how to bring about change than to anything else, but he is unlikely to succeed in his aim. And individuals may come to a reasoned philosophy about the products in their lives, but municipal waste is only about 2% of all PLC induced waste and one person simply will not affect the big picture directly. However, students who become designers create the PLCs for the many and can have considerable impact on the TFT of energy and materials, and on the social transformations created.

### **The Worldviews**

Obviously these six model categories are underwritten by very different world views. The dominant business model is usually capitalist in nature, and occasionally state capitalist – as in socialist states and socialist sectors of capitalist states such as defense. The diffusionist model documents the results of the business model and may be picked up by technological determinists. Yet it rarely penetrates design education beyond the search for global market share. The individual models include the customer needs model that is popular in engineering design education and is derived from the business model. However, the notion of a user whose needs are more than those of a largely artificial market place is replete with new directions for technology.



Thus buying what you like or are told to like is one variation of the user model but so is the idea of affective design whereby people buy what they truly like and keep the products for a long time thus weakening the business model. User happiness is more than a customer satisfaction survey is likely to measure, and both are very malleable.

### **Towards a Unified Theory of the Product Life Cycle**

One approach that might give us a meta-model is one that lets us characterize a product in terms of what is *embedded and encumbered* in the product. We know a product in use has *embedded* materials and energy in it representing the preceding processes of extraction, refining, and manufacturing, and distribution. But we might also embed values for waste, toxins, habitat loss and other externalized aspects of the global supply chains that brought the product to us. To this we can add the usual characterization of the use stage: energy use and damage caused such as loss of life, health and property and pollution, for example. There can also be metrics for what is *encumbered* in a product: the *expected* further use of energy and materials and environmental impact through continued use and then disposal. In this way we can capture the life cycle at any point in the process. An electric car for example, has little local environmental impact through fuel use, a good thing, but it has much the same embedded metrics for energy and materials as an internal combustion engine running on diesel. If the metrics include system requirements, such as the highway systems, again the metrics are much the same and differ only in refueling infrastructures. Whereas walking to work or using the internet to telecommute would make major changes in the TFT of the activity.

Other parameters for characterizing a product might be social such as measures of economic benefits in jobs and profits and for whom. Conversely, we might have measures for labor abuses, technological equity, resource depletion, and environmental impact.

So a useful meta-model would include metrics for a product that include the energy and materials used in all stages (embedded and encumbered), and similarly for the environmental and social impacts. We could argue about which metrics to use and the values assigned to each, but we would all be on the same stage. Creating such models would be a good research endeavor.

The central challenge to make this model work would be keeping the King of Bhutan, and Gilding, happy. Yet the way out of the dilemmas we have created for ourselves with an unsustainably high throughput of energy and materials, based to a large extent on inculcated needs, must be to take back control over the human needs for which we design. And we can only hope that when we do, the result will be more happiness with orders of magnitude less use of energy and materials. Reasonably enough, Gilding spends much of his book wondering how we might get there from a state that many feel is already cornucopia - and they are already happy. And while the ocean fish catch may have peaked, other resources have not. The U.S. has the most coal and nuclear plants in the world, and it has vast reserves of gas and oil in shales and sands available here and in Canada. This is why its alternative energy program is weak, the material need is not there. And if the North Pole ice cap melts, the U.S. and several other countries, will have access to more oil, not to mention more fishing opportunities and shipping routes. Gilding has to convince people who do not see a crisis that they have one, and people who are happy that they are not. And those who are unhappy now, usually want economic growth not a hug.

Defining such happiness may be more about answering the questions *design with whom* rather than *design for whom*, and *design with what* rather than *designing for what*. That is, we need to establish processes and hope that these will produce better outcomes rather than engage in top down pronouncements of what should happen and for whom. So participatory, open design, and localized PLCs with achievements like Linux, Wikipedia, Creative Commons, Blender.org offer an alternative path to the market which has produced such a prolific outpouring of goods and services in such an unsustainable way. Localized supply chains are a part of this also. As educators, we must keep truths alive even when the potential for change is small.

In *The Opposable Mind*, Roger Martin wrote that the ability to hold two conflicting ideas in constructive tension is a way in which decision-makers can synthesize new and better ideas. The above was written in that spirit, although we have expressed at least six points of view.<sup>55</sup>

## Bibliography

1. The Economist, “Two Thousand years in One Chart “ 28 June 2011.  
<http://www.economist.com/blogs/dailychart/2011/06/quantifying-history&fsrc=nwl> viewed 9/30/2011
2. The Washington Post, 23 April 2008 Robert J. Samuelson, “The End of Shopping.”  
<http://www.washingtonpost.com/wp-dyn/content/article/2008/04/22/AR2008042202520.html> viewed 9/30/2011
3. Gilding, Paul. *The Great Disruption: Why the Climate Crisis Will Bring On the End of Shopping and the Birth of a New World*. Bloomsbury Press, 2011.
4. 4. Wikipedia [http://en.wikipedia.org/wiki/Gross\\_national\\_happiness](http://en.wikipedia.org/wiki/Gross_national_happiness) viewed 9/30/2011
5. Wikipedia [http://en.wikipedia.org/wiki/Gross\\_national\\_product](http://en.wikipedia.org/wiki/Gross_national_product) viewed 9/30/2011
6. Simon, Herbert A. *The Sciences of the Artificial*. 3<sup>rd</sup> ed. MIT Press, 1996.
7. U.S. Congress, Office of Technology Assessment. *Green Products in Design Choices for Cleaner Environment*. U.S. Government Printing Office, 1992. Indira Nair, Panel Chair.
8. Meadows Beyond the Limits
9. Leopold, Aldo. *The Sand County Almanac*
10. Carson, Rachel. *Silent Spring*.
11. Merkhofer, Miley. *Decision Science and Social Risk Management*, Springer, 1986.
12. Wikipedia [http://en.wikipedia.org/wiki/National\\_Environmental\\_Policy\\_Act](http://en.wikipedia.org/wiki/National_Environmental_Policy_Act) viewed 9/30/2011
13. Op cit, #4 above.
14. Lau, Andrew S. “Green Design in First-Year Engineering.” *International Journal of Engineering Education*. Vol. 23, No. 1, 2007. See also,
15. Papanek, Victor, *The Green Imperative: Natural Design for the Real World*, Thames and Hudson, 1995; Graedel, T. E., and Braden Allenby *Industrial Ecology and Sustainable Engineering* Prentice Hall , 2009; McDonough, William, and Michael Braungart, *Cradle to Cradle: Remaking the Way We Make Things*, North Point Press, 2002; and Leonard, Annie, <http://www.storyofstuff.com/> Viewed 10/1/2011.
16. Wikipedia [http://en.wikipedia.org/wiki/Joseph\\_Schumpeter](http://en.wikipedia.org/wiki/Joseph_Schumpeter) Viewed 9/30/2011.
17. Neely, Paula, *National Geographic News*, 29 November 2010,  
<http://news.nationalgeographic.com/news/2010/11/101129-jamestown-personalized-pipes-virginia-history-colonial-america/> Viewed 9/30/2011.
18. *Constitution of the United States*, Article 1, Clause 8, [http://en.wikipedia.org/wiki/Enumerated\\_powers](http://en.wikipedia.org/wiki/Enumerated_powers) Viewed 9/30/2011.

19. "Obama's Innovation Agenda" *Forbes* 1/25/2011  
<http://www.forbes.com/sites/brianwingfield/2011/01/25/obamas-innovation-agenda/> Viewed 9/30/2011.
20. Wadha, Vivek "Immigration and The Death of the Recovery" *Innovations, Washington Post*, 6/29/2011.  
<http://www.forbes.com/sites/brianwingfield/2011/01/25/obamas-innovation-agenda/> Viewed 9/30/2011.
21. Ellul, Jacques. *The Technological Society*. Vintage, 1967.
22. Drucker, Peter. *The First Technological Revolution and Its Lessons*. 1965  
[http://xroads.virginia.edu/~DRBR/d\\_rucker5.html](http://xroads.virginia.edu/~DRBR/d_rucker5.html)
23. White, Lynn, Jr. *Medieval Technology and Social Change* Oxford University Press. 1962
24. Rogers, Everett, *The Diffusion of Innovations*. The Free Press. 5<sup>th</sup> Edition. 2003
25. Gladwell, Malcom. *The Tipping Point*. Back Bay Books. 2002.
26. Wiebe E. Bijker, Thomas P. Hughes, Trevor Pinch (Eds). *The Social Construction of Technological Systems: New Directions in the Sociology and History of Technology*. MIT Press, 1989
27. Daniels, George H., "The Big Questions in the History of American Technology." *Technology and Culture*. Vol. 11, No. 1, Jan 1970.
28. Wikipedia. [http://en.wikipedia.org/wiki/Lynn\\_Townsend\\_White,\\_Jr.](http://en.wikipedia.org/wiki/Lynn_Townsend_White,_Jr.) Viewed 9/30/2011.
29. Kotler, P., "Marketing Management: Analysis, Planning, Implementation and Control", Prentice Hall, 1967; 12th ed, 2006
30. Wikipedia [http://en.wikipedia.org/wiki/Product\\_lifecycle\\_management](http://en.wikipedia.org/wiki/Product_lifecycle_management) Viewed 9/30/2011
31. Economist, "Product Life Cycle," 3 November 2009, summarizes Kotler.  
<http://www.economist.com/node/14301365> Viewed 10/1/2011
32. samsung
33. DDT
34. Merkhofer, op cit.
35. Wikipedia, <http://en.wikipedia.org/wiki/Scenario> Viewed 10/1/2011
36. U&E
37. 37 Khalipha
38. Gregory M. Rose, David M. Boush, Marian Friestad (1998), "Self-esteem, Susceptibility to Interpersonal Influence, and fashion Attribute Preference in Early Adolescents, *European Advances in Consumer Research* Volume 3, eds. Basil G. Englis and Anna Olofsson, Provo, UT : Association for Consumer Research, Pages: 197-203.
39. The 17th century French used the word to represent "trick", "deceit" "imposture"  
([http://www.etymonline.com/index.php?l=p&p=46&allowed\\_in\\_frame=0](http://www.etymonline.com/index.php?l=p&p=46&allowed_in_frame=0)). Viewed 10/1/2011
40. Annette L. M. van den Bosch, Menno D. T. de Jong, Wim J. L. Elving, "Managing corporate visual identity: use and effects of organizational measures to support a consistent self-presentation," *Public Relations Review*, 30 (2004) 225–234
41. [http://www.lanl.gov/quarterly/q\\_w03/shelf\\_life.shtml](http://www.lanl.gov/quarterly/q_w03/shelf_life.shtml)
42. [http://en.wikipedia.org/wiki/Land\\_mine](http://en.wikipedia.org/wiki/Land_mine) Viewed 10/2011
43. [[http://www.chinadaily.com.cn/china/2010-08/07/content\\_11113982.htm](http://www.chinadaily.com.cn/china/2010-08/07/content_11113982.htm)].
44. Op cit, above.
45. IBM User-Centered Design <http://www-01.ibm.com/software/ucd/ucd.html> Viewed 10/1/2011
46. Usabilitynet on ISO standards <http://www.usabilitynet.org/trump/resources/standards.htm> Viewed 10/1/2011
47. <http://cool.conservation-us.org/byorg/abbey/ap/ap06/ap06-3/ap06-308.html>
48. Jordan, Patrick. *Designing Pleasurable Products*, CRC Press, 2002; Norman, Donald *Emotional Design: Why We Love (or Hate) Everyday Thing*. Basic Books, 2003; Boatwright, Peter, and Jonathan Cagan, *Built to Love*, Berrett-Koehler, 2010
49. Industrial Design Society Society of America, <http://www.idsa.org/> Viewed 10/1/2011
50. Toronto Globe and Mail, "Smart Phones: Blood stains at our fingertips." 12/03/2010  
<http://www.theglobeandmail.com/news/technology/smartphones-blood-stains-at-our-fingertips/article1825207/> Viewed 10/1/2100
51. <http://www.galbithink.org/ad-spending.htm> Viewed 10/1/2100
52. New York Times, "Voluntary Simplicity Movement Re-emerges" 05/18/2008,  
<http://www.nytimes.com/2008/05/18/world/americas/18iht-simplicity.1.12981659.html?pagewanted=all>  
Viewed 10/1/2100

53. Wikipedia. Gift. <http://en.wikipedia.org/wiki/Gift> Viewed 10/6/2011
54. Perrow, Charles. *Normal Accidents*, Basic Books, 1984.
55. Martin, Roger *The Opposable Mind*. Harvard Business School Press, 2007.

## **Detecting Airport Runways using Image Processing Techniques**

Renata Dukes, Kofi Nyarko, Jumoke Ladeji-Osias  
Morgan State University  
1700 E. Cold Spring Lane,  
Baltimore, MD 21239  
Renata.Dukes@Yahoo.Com  
Kofi.Nyarko@Morgan.Edu  
Jumoke.Ladeji-Osias@Morgan.Edu (corresponding author)

### **RENATA DUKES**

Reneta is a native of Baltimore, MD. She received her Bachelor of Science from Morgan State University in Electrical Engineering. She is currently pursuing her Master of Engineering in Electrical Engineering with a concentration in Computer Engineering. Her research interests include image processing, computer vision and network security.

### **KOFI NYARKO, D.Eng.**

Kofi is a research associate at Morgan State University in the School of Engineering. He teaches courses and conducts research in the area of visualization.

### **JUMOKE LADEJI-OSIAS, Ph.D.**

Jumoke is an associate professor at Morgan State University in the Electrical and Computer Engineering Department. She teaches courses and conducts research in the area of digital design.

# Detecting Airport Runways using Image Processing Techniques

## Abstract

Runway detection is essential to the safe landing of pilots during flight. The most dangerous risk associated with not being able to correctly identify a runway is a plane crash, resulting in the death of the passengers and flight crew aboard the aircraft. An effective detection system must discriminate between various textures, shapes and intensities to efficiently classify objects in the vicinity of the airport such as buildings, roadways, runways, and vegetation. Several research papers suggest numerous methods to detect runways in aerial imagery however each possesses limitations including limited detection of runways in large aerial images, night vision images, and infrared images. The overall goal is to automatically identify airport runways using aerial imagery, which will be universal to airports all over the world. This discusses the development of a detection system which uses spatial filters, connected component labeling, binary morphology, and the Hough transform to satisfy the overall goal.

## Background

Airport runways are often characterized as being an elongated rectangle possessing a defined length and width. Both shorelines and roadways can also satisfy this characteristic, resulting in the need to accurately detect runways. The image processing literature illustrates several techniques through which the identification of airport runways can be achieved. These techniques include Support Vector Machine (SVM), Kernel Mapping Pursuits (KMP), Canny or Sobel edge detection, and the Hough Transform. Once these techniques are combined they produce an algorithm, which assists in accurately detecting airport runways. Some of these algorithms require additional enhancement to account for situations such as low visibility, runways at night, runways captured through an infrared camera and significant texture differences in aerial imagery. Several assumptions were made regarding how to classify an object as an airport runway. One assumption is that all airport runways will have approximately the same width and length. Another is that airport runways have a similar intensity or hue associated with it. A third is that airports typically use two runways for departure and arrival. Additionally, the two main runways are overlapping at an acute angle.

Previous researchers have approached the detection of airport runways by outlining defined parameters. The authors assume that runways are always long, runway direction changes are likely to be small, runway local average gray is likely to vary only slowly, runway width variance is small and runway width change is likely to be slow, gray level variation between runway and background is likely to be large and runway local average intensity is often large (because runways are always white)<sup>1</sup>. Although these approaches to runway detection are successful, the methodology only satisfies finding the major runway line within the image. Other researchers approach runway detection by performing improved chain codes based edge tracking (ICCBET) with the Hough transform. The chain coding method helps in determining whether a particular line is straight or curved. The process is completed with the use of the Hough transform to localize the image and remove the rest of the unwanted lines. These methods show that the use of a filter and the Hough transform are techniques which will be essential to the detection of airport runway lines.

The Sobel and Prewitt filters are a first order derivative for sharpening information in an image. They both use the magnitude of a vector and perform the operation over the image using a 3x3 mask. Because the components of the gradient vector are derivatives, they are linear operators. The Canny operator has three main objectives which are low error rate, well localized edge points and single edge point response. The algorithm smoothes the input image with a Gaussian filter, computes the gradient magnitude and angle, applies a nonmaxima suppression to the gradient magnitude and uses double thresholding and connectivity to detect and link edges.<sup>3</sup> The Laplacian of Gaussian (LoG) is an advanced edge detection technique. The purpose of this technique influenced by Marr and Hildreth is that it should be a differential operator capable of computing a digital approximation of the first or second derivative at every point in the image and it should be capable of being “tuned” to act at any desired scale, so that large operators can be used to detect blurry edges and small operators to detect sharply focused fine detail.<sup>3</sup>

The four operations related to binary morphology are dilation, erosion, opening and closing. A dilation operation enlarges an image, while erosion makes it smaller. A closing operation can close up internal holes in a region and eliminate “bays” along the boundary. An opening operation can get rid of small portions of the region that jut out from the boundary into the background region.<sup>4</sup> Each operation requires a structuring element in order to perform a mathematical function to determine how the resulting picture will look. During dilation and erosion, the image performs an OR bitwise operation. The bitwise operation in conjunction with the structuring element and the original image determines if the resulting image will produce an area that will be enlarged or reduced. These two functions are combined to produce closing and opening. Opening is a sequence of erosion and dilation while closing is the sequence of dilation then erosion.

## Methods

Figures 1 and 2 shows the runways for the two airports (and their IATA airport code) used for testing and verification of each phase within the project. Phase 1 of this project explores four edge detection techniques; the Canny, Sobel, Prewitt and Laplacian of Gaussian operators. Phase 2 then selects the best operator and performs a series of image transformations that will isolate the runway lines of the airport. A connected component labeling algorithm is used to identify various blobs in the transformed image and then remove smaller blobs that do not satisfy the threshold for an airport runway. Phase 3 compares Laws’ Energy Texture Measures to edge detection. Along with Laws’ Energy Texture Measures, a series of image transformations and connected component labeling is used. Phase 4 eliminates connected component labeling, incorporates hue and uses a brute force attack method to address the angles of runways in multiple images. Finally, phase 5 eliminates the brute force method and uses the Hough transform to identify endpoints and lines in the airport images.

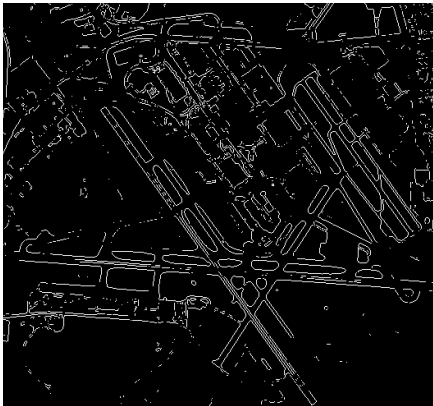
In Phase 1, the BWI and IAD airport images are converted to grayscale using MATLAB. The Sobel, Canny, Prewitt and Laplacian of Gaussian operators are applied to the image to determine which image produces better information for successful runway detection. Figures 3a to 3d shows the various edge operators applied to the grayscale images.



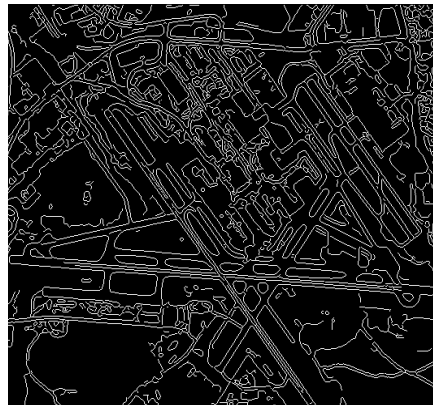
Figure 1: Baltimore Washington International Airport (BWI)



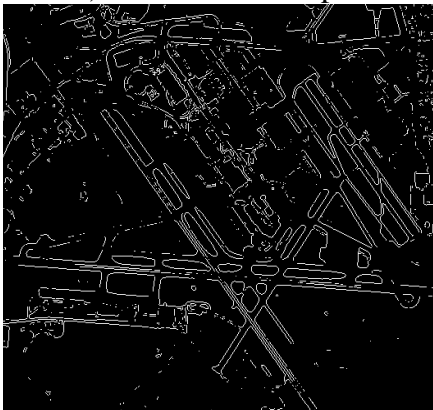
Figure 2: Dulles International Airport (IAD)



a) BWI – Sobel Operator



b) BWI – Canny Operator



c) BWI – Prewitt Operator



d) LaPlacian of Gaussian Operator

Figures 3a – 3d: Sobel, Canny, Prewitt and LaPlacian of Gaussian Operator on BWI

Figure 3a which uses the Sobel operator illustrates that lines which are representative of runways are present as well as several spotted areas which produce clutter. Figure 3b which uses the Canny operator produces an image with every edge visible. Figure 3c which uses the Prewitt



operator produces an image very similar to Figure 3a. Finally, Figure 3d which uses the Laplacian of Gaussian operator presents more information than those using the Sobel and Prewitt operators and less information than the image which uses the Canny operator. The same process is performed on IAD to provide comparison to the BWI images. The conclusion drawn from this process is that the Canny operator provides the most details that can assist in detecting airport runways.

During Phase 2, IAD is no longer process, due the similarity in results from Phase 1. Using the assumption that airport runway lines will have approximately the same width, length and intensity values, BWI was chosen to finish testing and analysis. This phase only makes use of the Canny operator once the image is converted to grayscale. Using the image transformation technique of closing, a combination of erosion and dilation, Figure 5a is produced. The structuring element used for this property is a disk with a radius of 3. Two thick white lines can be seen which identify two main runways for the airport. The goal is to remove the additional information from the image to produce only the thick white lines. Figure 5b then shows another iteration of an image transformation to remove the unwanted information. The connected component labeling method is then used to classify each blob and then remove unwanted blobs based on a given threshold.



Figure 5a: BWI using Closing

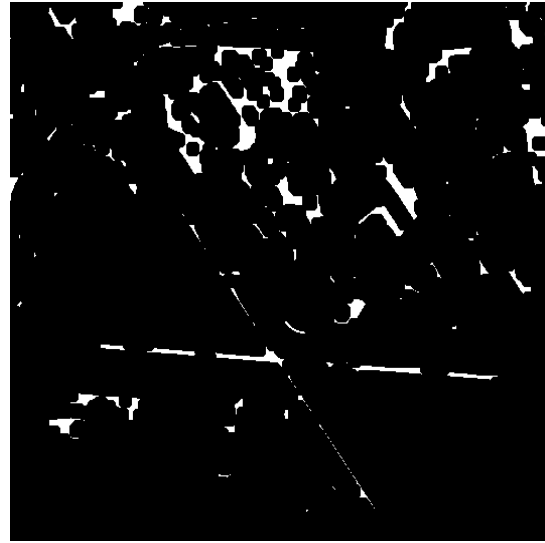


Figure 5b: BWI using Erosion on Figure 5

Figure 6a illustrates the connected component labeling of Figures 5a and 5b. By creating a threshold smaller blobs are then removed as illustrated in Figure 6b. Due to the gaps created during the image transformation process, portions of the runway lines have been removed. An assumption was made that the significant amount of edges provided by the Canny operator may contribute to the inability to detect the runway appropriately. This assumption is taken into consideration in Phase 3.

Phase 3 involves the use of Laws' Energy Texture Measures. This approach allows for various texture features to be identified or eliminated. Once the image is converted to grayscale,

the texture measure matrices are computed on a normalized image. Based on the 9 final images, there are a few which produce significant information essential to detecting the runway. Using the point tracing tool, the index value at various pixel locations is used to create a binary threshold which is intended to eliminate unwanted textures such as vegetation and buildings. Once the threshold is computed amongst the selected texture images, they were combined to produce a final image for runway detection. Binary image analysis was performed on the final image to outline the airport runway lines. Closing and dilation were used with disks of radiuses 4 and 3 respectively. Connected component labeling is then used to label and remove small blobs. Connected component labeling was not able to take place because of the increase in the amount of blobs using this method. As a result, the program continued to crash because the recursion limit was too high for the computer to handle. It was concluded that Laws' Energy Texture Measures on the grayscale image would not be sufficient enough to do connected component labeling. Using previous experience in Computer Vision, the idea to use information from the hue component in the next phase was explored.



Figure 6a: Connected Component Labeling



Figure 6b: Connected Component Labeling w/ Removal of Blobs

During phase 4 the the hue component of the original image was isolated as illustrated in Figure 8a. From this step the Laws' Energy Texture Measures are computed. Binary thresholding is then computed on the selected texture measures. A brute force method of generating 360 images, each representing 1 degree of rotation, is used to accommodate for the angle's at which airport runways lines can be situated. A combination of opening and dilation is used in this process where a line and rectangle are used for the structuring elements. The problem with this technique is that it is computationally intensive on the system. Although this addresses the angle of airports, another option must be used. The next phase looks into incorporating the Hough transform.

### Hue Image of BWI



Figure 8a: BWI using Hue Component

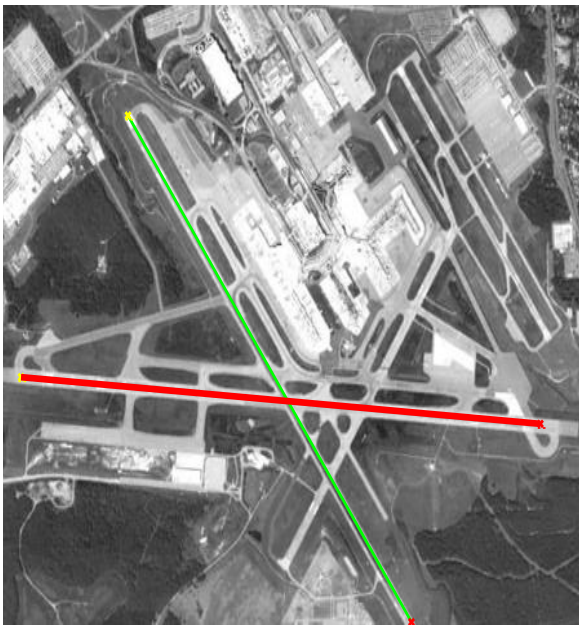


Figure 8b: BWI with Hough Transform

Phase 5 begins with the hue component of BWI, as in the previous phase. In addition, the Laws' Energy Texture Measures are computed with a binary threshold on the selected texture images. Phase 5 makes use of the Hough transform instead of binary image analysis to collect data on the peaks and angles of the image. Endpoints are then collected and lines are generated. The longest line is then determined from the generated lines as illustrated in Figure 8b. From this phase, it can be concluded that the Hough transform can be beneficial to runway detection. The techniques of phase 5 were used to see if additional runways lines would be detectable. The same information is used for IAD and produces a result which does not detect any lines of the airport runway. The assumption that all runways have a closely relative intensity is shown to be incorrect and additional investigation and testing must be done to satisfy the overall goal.

These phases illustrate that the technique used within this paper are all important to the detection of airport runways in an aerial image. The Canny operator distinguishes all edges within an image and does not eliminate any lines. The use of Laws' Energy Texture Measures and the Hough transform proved to be a nice technique however, was not successful due to the intensity differences in both images. Furthermore, the use of the Hue component may also be essential once the materials used in runway pavement are explored.

## **Future Work**

Additional work to be done on this project includes determining whether to continue using the hue component or revert to using the intensity of the images. Using additional thresholds based on hue and intensities can also assist in making feature extractions. This can be determined by identifying the various materials used to pave the runways. Additional research can be done to determine whether or not both the Canny operator and Laws' Energy Texture Measures will be beneficial in the detection of airport runways. Furthermore, testing can be done to determining whether or not the Sobel and Canny operators can be combined to fill in missing lines for better texture and line detection. Finally, using the Hough transform with additional parameters can effectively determine not only the main runways but additional runway lines that may be used for private or cargo flights.

## **Conclusion**

In conclusion, this project shows that a series of image processing and computer vision techniques can contribute to the detection of airport runways. Existing methodology is verifiable as seen in the use of the Canny operator for edge detection, as well as, the Hough transform. Additional techniques such as the Laws' Energy Texture Measures prove to be beneficial techniques which also help in feature extraction with the assistance of binary image analysis and binary thresholding. Connected component labeling also proves to be a technique which can be beneficial to eliminating unwanted lines such as shorelines, and roadways. The goal of detecting runways lines was achieved in the BWI image only. Additional research must occur to make the algorithm more general, to satisfy all airport runway cases.

## **Bibliography**

- [1] N. Di, M. Zhu, and Y. Wang, "Real Time Method for Airport Runway Detection in Aerial Images," *International Conference of Audio, Language and Image Processing*, 2008.
- [2] J. Han, L. Guo, and Y. Bao, "A Method of Automatic Finding Airport Runways in Aerial Images," *International Conference on Signal Processing*, 2002.
- [3] R. C. Gonzalez and R. E. Woods, *Digital Image Processing*. New Jersey: Prentice-Hall, Inc. 2008.
- [4] L. Shapiro and G. Stockman, *Computer Vision*. Prentice-Hall, Inc. 2001

**Deflection Part II: Solving Complex Machine Design Problems  
Using an Alternative Mechanics of Materials Approach**

C.J. Egelhoff

United States Coast Guard Academy, New London, CT

J.M. Ryan

United States Coast Guard Academy, New London, CT

E.M. Odom

University of Idaho, Moscow, ID

## Deflection Part II: Solving Complex Machine Design Problems Using an Alternative Mechanics of Materials Approach

C.J. Egelhoff<sup>1</sup>, E.M. Odom<sup>1</sup> and J.M. Ryan<sup>1</sup>

<sup>1</sup> United States Coast Guard Academy, New London, CT

<sup>2</sup> University of Idaho, Moscow, ID

### Abstract

In this paper, an alternative approach is used and extended to consider the impact of indeterminate supports and the impact of transverse shear on deflection and moment. It is shown that transverse shear increases the shaft deflection as much as 50%. Additionally, a condition of shaft misalignment at  $\pm 0.002$  inches is investigated and shown to increase bending stresses by 20%. Ultimately the fatigue safety factor and expected life of a complex rotating shaft is presented.

*Index Terms* – Deflection, Equation-solving software, Non-uniform diameter, stepped shaft, Castigliano's Theorem, Heaviside function, shaft misalignment, shear deflection.

### Introduction

Beam deflection is one of the more difficult skills for students to master in their study of Mechanics of Materials. However, students in the study of Machine Design need to be proficient in the determination of deflection especially for shafts, which are routinely subjected to multiple loads, are supported by multiply indeterminate reactions, and which must frequently and nearly perfectly mesh with gears (Figure 1).

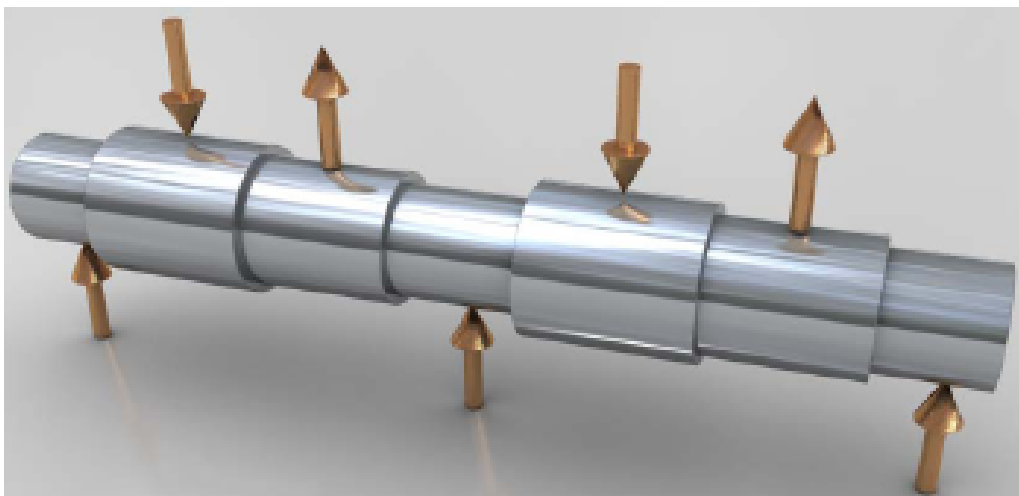


Figure 1. Rendered image of the Hopkins shaft [1].

Added to the loading complexities, shafts also require designs with multiple diameter changes to accommodate sprockets, pulleys and cams attached to those shafts using keys, splines, tapers and shoulders; these diameter changes and attachments further complicate the calculation of shaft deflection.

Recently an alternative approach for the deflection calculation has emerged which requires merely undergraduate-level problem formulation skills to produce analytical results for graduate-level shaft geometry. This alternative approach is based on the method presented by Professor Ju in his course notes and in an article [2]. Professor Ju used Castigliano's Theorem and the Heaviside step functions to write the moment equation. If the integration is performed by hand, this approach is algebraically intense. However, by keeping the solution in generalized variable form until the numerical solution is accomplished, the boundary conditions are embedded in the formulation, and once created, the formulation is ready for direct input into one's favorite equation solving software. [3] When an equation solver is incorporated, it is straight-forward to find deflection virtually "everywhere" along a beam; the results can be obtained in about the same amount of time as an ordinary (and easy) beam deflection problem is solved using paper and pencil.

Overall, the process consists of the following steps:

- (1) applying a dummy load, and solving for static support reactions,
- (2) writing a moment equation in Macaulay form augmented with Heaviside step function variables,
- (3) taking a partial derivative of the moment equation with respect to the dummy load,
- (4) re-writing the moment equation to eliminate the dummy load and finally,
- (5) using the results of steps 3 and 4 to develop the deflection calculation via Castigliano's Theorem applied parametrically to create a deflection curve for the entire length of the beam.

The positive aspects of this alternative process include (a) the governing equation writing is systematic and straight-forward since it relies primarily on knowledge of statics and moment equations, (b) the generalized form allows maximum usefulness and (c) since students select their personal equation-solving software of choice, the coding proceeds quickly to obtain results.

Before computers were ubiquitous, engineers designed stepped and tapered shafts using elegant but time-consuming graphical techniques [4-5]. With the availability of scientific calculators and mainframe computers, semi-graphical and computer-programmed techniques appeared [6-8].

In today's undergraduate Machine Design textbooks, we see three general approaches to the solution of deflection for stepped or tapered shafts. One approach is graphical. A second approach is the use of discontinuity functions to write a moment equation,  $M(x)$ , or modified moment equation,  $\frac{dM(x)}{dx}$ , which is integrated twice and constants of integration are determined using boundary conditions [9-13].



### Alternative Mechanics of Materials Approach to Solve for Deflection

We present an energy-method-based solution for these practical shaft geometries and loadings. The method stays generalized and requires only knowledge of free body diagrams, writing moment equations, and Castigliano's theorem to set up the problem solution into a form that is solved using an equation-solving computer program. What's new in this paper, is the use of Heaviside step functions to write the moment equation, a virtual axis identified by the variable  $\xi$  which specifies the point of interest for finding a deflection, and a user-defined function to indicate the diameter along the shaft during numerical integration. [14-15]

By Castigliano's theorem the deflection is based on the strain energy,  $U$ , stored in an elastic beam loaded in bending. The strain energy is given as:

$$U = \int_0^L \frac{M^2}{2EI} dx \quad (1)$$

The deflection,  $\delta$ , at a location,  $\xi$ , is given as the partial derivative of the strain energy with respect to a load at the " $\xi$ " location [13].

$$\delta_\xi = \frac{\partial U}{\partial P} = \int_0^L \left( \frac{M}{EI} \right) \left( \frac{\partial M}{\partial Q} \right) dx \quad (2)$$

The solution process to evaluate the integral can be described using five steps as follows:

- Step 1: Draw free body diagram (FBD) with dummy load  $Q$ , at secondary axis location,  $\xi$ , and solve for reaction forces using statics.
- Step 2: Write the moment equation  $M(x, \xi)$  for the entire length using discontinuity terms coupled with a Heaviside function  $H(x, \xi)$ .
- Step 3: Take the partial derivative with respect to the dummy load,  $\left( \frac{\partial M(x, \xi)}{\partial Q} \right)$ .
- Step 4: Set  $Q=0$  and write  $M(x, \xi)$  for  $Q=0$ .
- Step 5: Write the integral  $\delta_\xi = \frac{1}{E} \int_0^L \left( \frac{M(x, \xi)}{I(x)} \right) \left( \frac{\partial M(x, \xi)}{\partial Q} \right) dx$ , and then solve for any  $\xi$  using equation-solving software. (In this work, we have used EES<sup>®</sup> and TKSolver<sup>™</sup>.)

To demonstrate the utility of this approach, a challenging shaft geometry and loading by Hopkins [1] was selected (Figure 1). It should be noted that this is a shaft that has six changes in cross section, four loads and a redundant support. The solution will show the steps to calculate the deflection along the shaft's length.

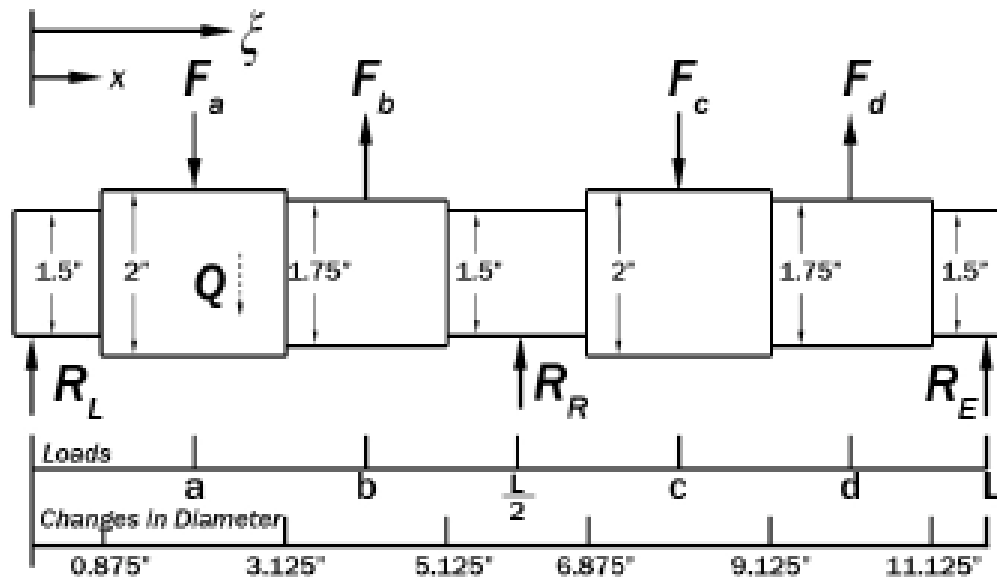


Figure 2. FBD of Hopkins Shaft with External Loads and Dummy-Load,  $Q$ , for statics analysis.

**Step 1:** Draw FBD and solve statics

A dummy,  $Q$ , is applied at an arbitrary distance,  $z$ , from the origin, in the negative direction as shown (Figure 2).

To solve for reaction forces, the equilibrium equations ( $\sum M=0$ ;  $\sum F=0$ ) are used. First summing moments about the left reaction,

$$-F_a(a) - F_b(b) + R_R \left(\frac{L}{2}\right) - F_c(c) - F_d(d) + R_E L - Qz = 0 \quad (3)$$

$$R_L - F_a - F_b + R_R - F_c - F_d + R_E - Q = 0 \quad (4)$$

Using (3) and (4), we solve explicitly for the support reactions as follows:

$$R_R = \frac{2[F_a(a) - F_b(b) + F_c(c) - F_d(d) - R_E L + Qz]}{L} \quad (5)$$

$$R_L = F_a - F_b + F_c - F_d - R_R - R_E + Q \quad (6)$$

Before proceeding to the Moment equation, we want to define the Heaviside function as:

$$H(a, b) = \begin{cases} 0 & \text{if } a \leq b \\ 1 & \text{if } a > b \end{cases} \quad (7)$$

The Heaviside function,  $H(x, \xi)$ , serves as a "switch" to turn "on" or turn "off" individual terms in the moment equation.

Step 2: Write the moment equation  $M(x, \xi)$  for the entire shaft using the Heaviside function.

$$M(x) = R_1 x - F_a(x-a)H(x, a) + F_b(x-b)H(x, b) + R_x \left(x - \frac{L}{2}\right) H\left(x, \frac{L}{2}\right) - F_c(x-c)H(x, c) + F_d(x-d)H(x, d) - Q(x-\xi)H(x, \xi) \quad (8)$$

Step 3: Substitute in the reaction forces found from equations (5) and (6) into equation (8) above, then take the partial derivative with respect to the dummy load,  $Q$ , obtaining (9) below.

$$\frac{\partial M}{\partial Q} = \left(1 - \frac{2\xi}{L}\right)x + \frac{2\xi}{L}\left(x - \frac{L}{2}\right)H\left(x, \frac{L}{2}\right) - (x - \xi)H(x, \xi) \quad (9)$$

Step 4: Set  $Q=0$  and write  $M(x, \xi)$  for  $Q=0$ . The result is shown in (10).

$$M(x) = R_1 x - F_a(x-a)H(x, a) + F_b(x-b)H(x, b) + R_x \left(x - \frac{L}{2}\right) H\left(x, \frac{L}{2}\right) - F_c(x-c)H(x, c) + F_d(x-d)H(x, d) \quad (10)$$

Where

$$R_1 = F_a - F_b + F_c - F_d - R_x - R_x$$

$$R_x = \frac{2[F_a(a) - F_b(b) + F_c(c) - F_d(d) - R_x L]}{L}$$

Step 5: Substitute the expressions from Equations (9) and (10) into (2) repeated below and solve parametrically for various values of  $\xi$  (each  $\xi$  corresponds to a  $\delta_c$ ).

$$\delta_c = \frac{\partial U}{\partial P} = \int_0^L \left(\frac{M}{EI}\right) \left(\frac{\partial M}{\partial Q}\right) dx \quad (2)$$

### Initial Deflection and Solution for Indeterminate Support

Shafts of a stepped geometry have been documented in several publications [12, 13] so in this paper, we'll proceed directly to addressing the indeterminacy and shear deflection using the alternative approach.

Using the governing equations developed in Equations (8), (10) and (2) above, populated by the variable values as listed at right in Table 1, then assuming the rightmost support,  $R_a$ , to be absent, the statics analysis results in  $R_c=1787.5$  lb and  $R_d=12.5$  lb. The deflection is then determined for the entire shaft which reveals deflection at the unsupported right end to be  $\delta_c=0.006553$  inches upward as shown in Figure 3 (left).

Next a support value is estimated and the deflection is calculated iteratively until the deflection is zero at the right end. The support force of  $R_a=-529.5$  lbs produces the desired zero deflection. The deflection curve with the third support is shown in Figure 3 at the right (vertical axis magnified to show detail).

Table 1  
Variable Names and Values

Variable	Value
a	2 in
b	4.125 in
c	8 in
d	10.125 in
$F_a$	3000 lb
$F_b$	2100 lb
$F_c$	3000 lb
$F_d$	2100 lb
L	12 in
E	$30 \times 10^6$ psi
$I_{cross}$	0.248 or 0.785 in <sup>4</sup>
$R_c$	1787.5 lb
$R_d$	12.5 lb
$R_a$	

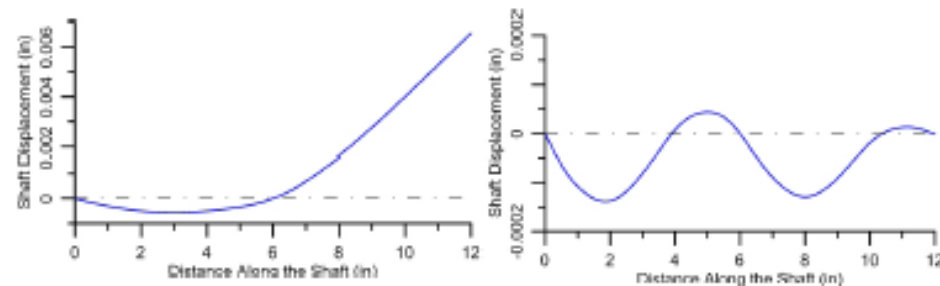


Figure 3. Left: Deflection of stepped shaft with indeterminate support  $R_a$  set equal to zero. Right: deflection of stepped shaft with  $R_a=-529.5$  lb bringing deflection at right end back to zero (vertical axis magnified to show detail).

### Validation of Governing Equations and Equation Solver Input

To validate that the input was correct, we first used a constant diameter and calculated the deflection of the shaft without the rightmost support in two ways: first with the superposition method and second with Equations (9), (10) and (2) using the equation solver. We determined the magnitude of the redundant support using two different diameters (1.5-in and 2-in). We graphed the moment diagram using Equation (10) to guarantee it agreed with the Mechanics of Materials moment one would construct for any ordinary moment analysis. When we were

satisfied that our constant diameter solution was correct, we introduced the multi-step cross-sectional configuration of this indeterminate shaft.

Since the superposition technique does not apply to deflections of beams or shafts which are non-prismatic, we solved for the redundant support using an iterative approach.

We plotted the moment diagram of the stepped-diameter shaft and compared it to the moment diagram of the constant-diameter shaft (Figure 4) and we observed that *because of its multi-stepped cross-section, the stepped diameter configuration increases both the maximum positive and negative moment for this shaft with its multiple point loads and indeterminate supports.*

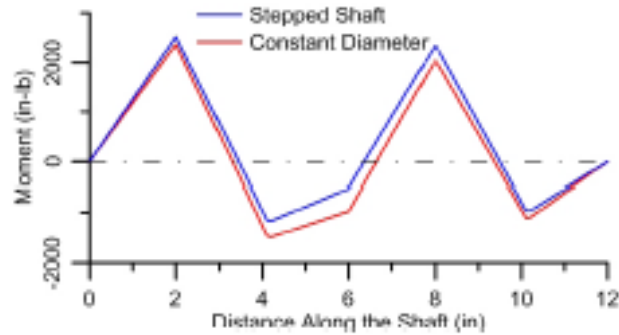


Figure 4. Comparison of moment diagrams for constant-diameter and stepped-diameter shafts with indeterminate supports.

### Effects of Shear Forces on Deflection

In addition to the deflection due to the bending loads, we suggest consideration of the deflection due to the shear forces on this beam. This *shear deflection* is usually ignored in design calculations; even so, it is easy to include using the alternative approach described in this work, and we offer this as a further example.

Using superposition [16], we combine the deflection due to bending with the deflection due to shear, using the following relations:

$$\delta_Q = \int_0^L \frac{M}{EI_x} \frac{\partial M}{\partial Q} dx + \int_0^L \frac{\alpha V}{GA_x} \frac{\partial V}{\partial Q} dx$$

$\alpha$  is the shear deflection shape factor (1.2 for solid round shafts)  
 $V$  is the vertical shear force  
 $G$  is the modulus of rigidity (12,000,000 psi for steel)  
 $A_x$  is the cross-sectional area of the shaft at the point of interest

Since we have already solved the first integral for locations “everywhere” on the shaft, we need only write the shear equation in Heaviside step function form and take the partial derivative to develop the shear force integral to augment our existing results.

The shear equation is:

$$V(x) = R_1 - F_a \cdot H(x, a) + F_b \cdot H(x, b) + R_x \cdot H\left(x, \frac{L}{2}\right) - F_c \cdot H(x, c) + F_d \cdot H(x, d) + R_x \cdot H(x, L) \quad (11)$$

Where

$$R_x = \frac{2[F_a(a) - F_b(b) + F_c(c) - F_d(d) - R_x L]}{L}$$

$$R_1 = F_a - F_b + F_c - F_d - R_x - R_x$$

And the partial derivative with respect to the dummy load,  $Q$ , is:

$$\frac{\partial V(x)}{\partial Q} = \left(\frac{L - 2\xi}{L}\right) + \frac{2\xi}{L} H\left(x, \frac{L}{2}\right) - H(x, \xi) \quad (12)$$

Simply substitute Equations (11) and (12) into Equation (13), and add the shear deflection result to the bending deflection calculated at every section location,  $\xi$ .

$$\delta_\xi = \int_0^L \frac{\alpha V(x) \partial V(x)}{GA_x} dx \quad (13)$$

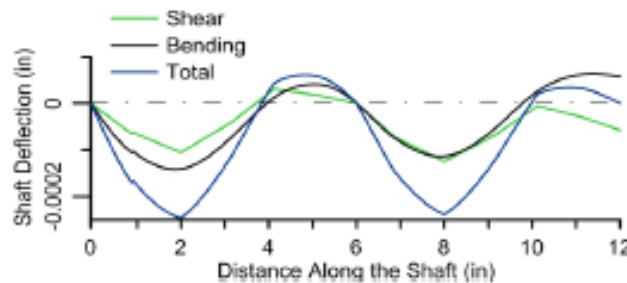


Figure 5. Deflection due to bending and shear.

Conventional wisdom has stated that the contribution to deflection by transverse shear forces is negligible unless the beam is “short” or “deep.” One Machine Design text, for example, suggests the general rule “for rectangular-section beams of length at least eight times depth, transverse shear deflection is less than 5 percent of bending deflection” and that “it is unusual for transverse shear to make a significant contribution to any engineering deflection problem.” The latest edition of another Machine Design text advises that shear must be considered if the shaft length to diameter ratio is ten or less [13].

What we observe with this shaft and its geometry is that the total deflections are small but that the shear component is nearly 50% of the total deflection. It should be noted that the vertical scale in Figure 5 contains a vertical scale magnified 10x compared to Figure 3 above. If taken in isolation, these results support the recommendations of shaft length/diameter ratios. However, we see in the next section that the shear contribution can be more a function of overall deflection magnitude than of length/diameter ratio.

### Effects of Bearing Misalignment on Deflection and Moment

For a simply-supported beam whose supports are misaligned, the slope at those supports changes due to the misalignment, but the support reactions remain unchanged in magnitude. For an indeterminate beam such as the one we are considering here, misalignment at even a single support may change the bending moment, the reaction values and the deflection significantly.

Assume the right support,  $R_a$ , is misaligned by 0.002 inches and the shaft deflects 0.002 inches at the right support (as done in [1]). Next, calculate the deflection and graph it according to the contributions by bending and shear forces, and sum them. The results in Figure 6 show that shear, in this case, contributes almost nothing to the total deflection. The deflection depends much more on the 0.002 inches of misalignment, even though the length/diameter ratio is between 6 and 8 for this shaft. We would say then, that shear deflection ought to be calculated as a matter of course because (1) we cannot tell *a priori* when it will matter and (2) because including shear deflection is easy using this alternative analytical approach.

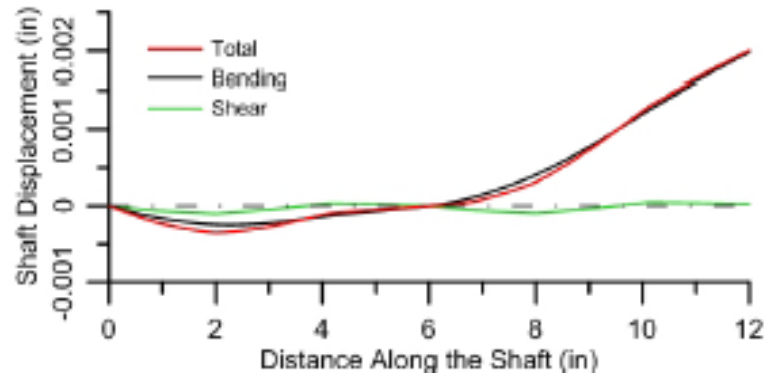


Figure 6. Deflection along the shaft where a 0.002-inch misalignment exists at the rightmost support,  $R_a$ .

Finally, we consider the direction of misalignment (unspecified in [1]). We compare the aligned configuration to both the upward and downward misalignment conditions at the right support and observe the effect on the deflection of the entire shaft (Figure 7). Regardless of the misalignment direction, the shaft deflection is changed along its entire length. Likewise, the moment also changes as a result of misalignment, and the effects are significant, 15%-35%, at the locations of two loads. These conditions create proportionately increased normal stress on this shaft. Moreover, compounding the increased stresses due to misalignment is the fully-reversed nature of the loading (and hence the reversed stress), potentially enhancing fatigue effects and shortening useful life. Although a misalignment of only  $\pm 0.002$ -inches may seem small, and it may be unavoidable, it may not be benign. The relationship between bearing radial load and bearing life should be investigated to uncover the cascading ramifications of shaft misalignment.

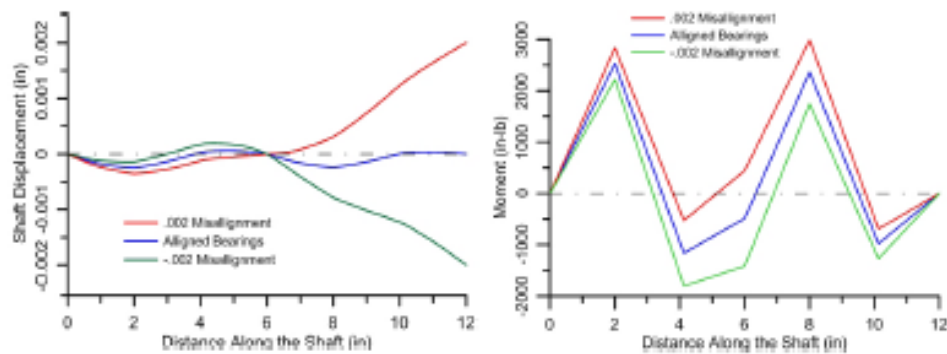


Figure 7. LEFT: Comparison of shaft deflection. RIGHT: Comparison of shaft moment. BOTH: for right support misalignment of magnitude  $\pm 0.002$  inches

### Conclusion

We have applied an alternative approach to the analysis of a statically indeterminate stepped shaft with multiple loads. We used fundamental skills of applying a dummy-load, solving statics, writing moment equations and taking a partial derivative, then building a numerical solution based on Castigliano's theorem augmented by the Heaviside step function, and finally solved for shaft deflection using an equation solver. We further investigated the effect of shear forces on deflection, finding that shear contributes significantly to deflection when the deflection is small. Additionally, we investigated the effects of single-support-misalignment, finding the impact of misalignment is significant regardless of its direction. With misalignment the bending stresses increase as much as fifteen to thirty-five percent which shortens the expected life predicted using fatigue analysis. Finally, we suggest that shear forces ought to be considered in the analysis of shaft deflection and that shaft misalignment, while unavoidable, is not benign and may contribute to a shortened bearing life.

### Acknowledgment

We are very grateful to Alexander Odom for contributing the beautiful shaft image rendered using SolidWorks<sup>™</sup> and Rhinoceros<sup>®</sup>.

### References

- 1 Hopkins, R. Bruce, "Calculating Deflections in Stepped Shafts and Nonuniform Beams," *Mechanical Design*, p. 159-164, July 6, 1961.
- 2 Ju, F.D., "On the Constraints for Castigliano's Theorem," *Journal of the Franklin Institute*, Volume 292, No. 4, Pages 257-264, 1971.
- 3 We have successfully used TK Solver<sup>™</sup>, EES<sup>®</sup>, Mathematica<sup>®</sup>, Matlab<sup>™</sup> and MathCad<sup>®</sup> using the alternative approach described in this paper.



- 4 Schroeder, Walter, "Beam Deflections," *Machine Design*, p. 85-90, January 1947.
- 5 Cowie, Alexander, "A Tabular Method for Calculating Deflections of Stepped and Tapered Shafts," *Machine Design*, p. 111-118, August 9, 1956.
- 6 Margolin, Lawrence L., "Calculating Deflections in Variable- Section Beams," *Machine Design*, p. 173-181, March 16, 1961.
- 7 Halasz, Sandor T., "Mimic also find Stepped- Shaft Deflections," *Machine Design*, p. 78-82, June 27, 1974.
- 8 Hopkins, Bruce R., *Design Analysis of Shafts and Beams*, Mc Graw-Hill Book Company, New York, NY, 1970.
- 9 Collins, Jack A., Henry Busby and George Staab, *Mechanical Design of Machine Elements and Machines*, 2<sup>nd</sup> Edition, John Wiley & Sons, Hoboken, NJ, 2010.
- 10 Spotts, Merlyn F., Terry E. Shoup and Lee E. Homberger, *Design of Machine Elements*, 8<sup>th</sup> Edition, Pearson Prentice Hall, Upper Saddle River, NJ, 2003.
- 11 Mott, Robert L., *Machine Elements in Mechanical Design*, 4<sup>th</sup> Edition, Pearson Prentice Hall, Upper Saddle River, NJ, 2004.
- 12 Juvinal, Robert C. and Kurt M. Marshek, *Fundamentals of Machine Component Design*, 4<sup>th</sup> Edition, John Wiley and Sons, Inc, Hoboken, NJ, 2006.
- 13 Budynas, Richard G. and J. Keith Nisbett, *Shigley's Mechanical Engineering Design*, 8<sup>th</sup> Edition, Mc Graw-Hill, New York, NY, 2008.
- 14 Odom, Edwin and C.J. Egehoff, "Stepping Through Shaft Deflection Calculations," *Machine Design*, pp. 58-60, June 10, 2010. Available online at <http://machine-design.com/article/calculate-deflection-in-stepped-shafts-the-easy-way-0608>
- 15 Odom, E.M. and C.J. Egehoff, "Teaching Deflection of Stepped Shafts: Castigliano's Theorem, Dummy Loads, Heaviside Step Functions and Numerical Integration," *Proceedings of the Frontiers in Education Conference*, Rapid City, SD, October 12-15, 2011. Available online at <http://fie-conference.org/fie2011/papers/1541.pdf>
- 16 Bert, Charles W., "Deflections in Stepped Shafts," *Machine Design*, p. 128-133, November 24, 1960.

**The Second Paradigm Shift-Emerging Graduate Engineering Education**

HOWARD EISNER

Distinguished Research Professor and Professor  
Engineering Management and Systems Engineering Department  
School of Engineering and Applied Science  
The George Washington University  
1776 G Street NW, Washington, DC

## **THE SECOND PARADIGM SHIFT - EMERGING GRADUATE ENGINEERING EDUCATION**

### **Abstract**

Today's modern University education system can be construed to have begun in the 1600s. With relatively minor perturbations, that system has survived, mostly intact, into the 20<sup>th</sup> century. In the latter part of the last century, however, a major "paradigm shift" began to take hold. As a central focus, the Internet took its place as a new framework within which to design and deliver instructional materials to large numbers of students. Instructors could use e-mails to establish dialogues, with whatever level of personalized attention seemed to be appropriate, short of giving lectures in the classroom with the students in front of them. We remain under the influence of that educational shift, and are likely to be so involved for the indefinite future. However, a second and more subtle paradigm shift has also shown itself in graduate engineering education. For want of a better term, this will be called the shift toward "cohort-based" education, and may be characterized by at least the following five features:

1. Students as parts of cohorts that take courses in lock-step
2. A focus upon graduate-level courses and degrees
3. Delivery of the sets of courses to the doorstep of participating entities
4. Formal agreements made between Universities and participating entities
5. Influences, hopefully for the better, of the participating entities, into the educational system

This paper explores each of the above features. This is followed by an overview of a significant experiment to date, with a form of cohort-based education, in a University environment. The central focus of this education has been at the Master's level. With the benefit of a real-world example, the paper goes on to set forth some possible future scenarios for cohort-based education. These include major modifications in the mix of public vs. private education as well as possible changes in the ownership of educational institutions.

### **INTRODUCTION**

The first paradigm shift, as alluded to in this paper, is the e-learning phenomenon. It is now well established, using the Internet and the relatively large number of ways graduate engineering courses can be conveyed by using this medium. Some Universities have completely embraced this approach and capability, while others have tended to insist upon teaching "the old fashioned way" – a lot of face-to-face contact between professors and students. It seems likely that despite the latter, and all its excellent features, e-learning is here to stay, probably for a very long time. It is not the focus of this paper, but it remains a very powerful and pervasive first paradigm shift.

### **THE SECOND PARADIGM SHIFT**

The second paradigm shift, as referred to here, is toward "cohort-based" graduate engineering education. We can explore its basics by contrasting it with a more conventional approach. For the latter, the University typically describes its graduate programs, and the students, one by one, decide which programs to sign up for. They are on their own, and they fashion a course of study whose content and pace is completely based upon their individual desires as well as their constraints. Constraints include their ability to pay, timetables, and the possible need for various prerequisites. This approach is highly individualized, and has been the primary way in which graduate engineering education has occurred.

## **Cohort-Based Graduate Education**

In distinction to the above approach, we now see the “cohort-based” approach. This approach recognizes that, for graduate engineering, a large percentage of the students work full time in either industry or for the government. Being part of the graduate engineering community, their places of employment are anxious to see them improve their skills, and are also willing to pay for most of their graduate education. Typical numbers lie in the 75 to 100 percent of the costs, given successful completions at or above the grade of “B”. Therefore, policies regarding payment and support of employees in industry and government are strongly conducive to student participation. It’s a good deal for the students and a good deal for their employers.

Within this scenario, we see agreements being made between Universities, industrial firms and government agencies such that cohorts of students are formed that go through specific courses of study that lead to Master’s degrees. The fields of interest are consistent with what industry and government need, and what the Universities are prepared to deliver, with special attention and distinction. Such fields include, but are not limited to:

- Systems engineering
- Knowledge management
- Information systems
- Cybersystems and security
- Software engineering

So what we have is a growing relationship between academia and both industry and government such that the latter are able to participate more directly in terms of what their employees learn and what they can therefore bring to bear in the working environment. Industry and government find this to be very attractive, and they get quite a lot for this new approach, as compared with the non-cohort approach.

### **Course Delivery**

Courses that are part of the Master’s program are made as convenient as possible for the students. Often, this means delivery to the premises of the industrial firms and the government agencies. Times are also selected for convenience. A course from 5:30 to 8:00 PM works perfectly in that respect. Students can finish their day at work, get a bite to eat, and ride the elevator a few floors to get to the class by the start time. If the cohort includes students three time zones earlier, for example, then some of the students participate using their employer’s video teleconferencing facilities, and also have approval to use classroom space and spend their own time in a class during normal working hours.

### **Course Payments and Agreements**

The essence of the agreements between academia, industry and government deal with payments per person, size of guaranteed cohorts, focus of academic programs, course delivery locations and overall schedules. Payments are in consonance with the University’s policies and are, in general, lower than credit-hour costs for the standard on-campus offerings. The rationale for lower costs is entirely defensible, based upon lower facility costs, as a minimum. Desirable cohort size is about 30 students, but can be larger when cohorts include students from several locations. Students selected to be part of a cohort see this choice as being treated in a special way by their employer. In some cases, they may also be eligible for greater benefits when they have completed the courses of study. These benefits include cash bonuses and stock options, as well as consideration for the next “higher” job. The program focus can be whatever the parties agree to, including the fields cited earlier. Delivery locations tend to be where the greatest number of

people in a cohort go to work every day. Courses in the same building represent a great convenience for the students. Finally, schedules can be based upon each student taking three courses per year, a twelve course program (36 credits), and therefore an overall time frame for completion of some four years. This is a comfortable pace that is compatible with student capabilities as well as typical student workloads.

### **Nature of Participation**

In this context, participation refers to the role of the sponsoring enterprise. The nature of such participation is a variable that is agreed to between the concerned parties. The basic premise is that the industry firm and government agency wish to sponsor their employees so that they (a) learn more about subjects and topics that the firm and agency consider important, (b) are able to obtain a Master's degree directed toward these subjects and topics, and (c) become key players in moving the firm and agency forward in the years to come.

Typically, the University is open to receiving ideas from the firm and agency as to what is important and what is not. The views of industry and government are not necessarily the same. In any case, the University takes all ideas as inputs to be considered. However, the University, of course, reserves the right to ultimately decide the courses to be offered as well as the content for each course. In all cases, a set of progressive relationships is based upon an understanding of what Senge called the "learning organization"<sup>1</sup>. All three parties (industry, government and academia) should be "learning" as they proceed with these types of programs and relationships.

### **Student Benefits**

Under this shift in graduate engineering education, students lose some freedom of choice but gain a lot in terms of (a) having all the planning done for them, (b) having their employer improve the nature of sponsorship, (c) share in additional monetary benefits, (d) being part of a cohort, and (e) being able to provide inputs to both the University as well as their employers.

The firms and agencies typically announce the program and employees apply to be part of a cohort. Those that are accepted as part of a cohort have achieved something special within their organizations. Basically, from that point, all the planning is out of their hands, and they proceed for four years as part of the cohort. For many, that is a great relief. Further, the companies and agencies wish to treat all participants in a special way, to include monetary benefits. Such benefits include, as noted previously, course payments, cash bonuses and stock options for successful completion. As members of a cohort that stays together for four years, they form additional and special bonds with fellow employees, and are able to use these connections both in the classroom as well as in the work environment. Since the students "cut across" levels of placement in the enterprise, students can make contacts and friends that typically go beyond what they could achieve otherwise. This helps them in their overall careers within the enterprise. Finally, if students have special ideas that might contribute to improvements in the various courses, they are able to move forward with them in two distinct directions: (1) bring them up directly in the classes themselves, and (2) send them off to the appropriate personnel within the firm or agency (i.e., their employers).

### **Selected Experience**

This author has been directly associated with cohort-based programs for more than ten years. It has therefore been possible to both establish such programs as well as observe how they operate over this entire period of time. All of this experience is at one University so the author has no first-hand knowledge of how such programs have been operating at other Universities. Nor has there been any systematic attempt to gather this type of information. Given this background, the author sets forth the following ten points that tend to support the notion that we are indeed at the beginning of a serious paradigm shift in engineering graduate education, based upon student cohorts:

1. **Physical Convenience** – Students that are part of a cohort come to class in the same building as their offices, or in close proximity
2. **Fee Payment Convenience** – In the main, total or partial payments are made directly from the company or government agency to the University. This simplifies the lives of the students and improves their cash flows
3. **Student Networking** – Relationships are established between students in a cohort which helps them in the learning process and facilitates team problem solving and exercises
4. **Inputs from Company and/or Government Agency** – Inputs regarding the technical as well as administrative parts of the program are sought which leads to improvements in the overall program
5. **Current Issues and Problems** – Inputs from the students are sought regarding the current issues and problems with which they are faced so that class exercises can be more sharply focused and relevant
6. **Part of Reward System** – Students selected for the program see that selection as part of the reward system from the company and the government agency. Indeed, that is the intention, which provides an additional element of motivation
7. **Assurance to the Company and Government Agency** – The overall format of the program tends to assure the participating companies and agencies that the monies they are spending for education are well spent
8. **Student Travel** – Many of the students have serious travel requirements that are part of their jobs. By being part of a cohort, they are able to stay connected to other members of the cohort during travel days, and therefore are better able to keep up with the courses even when they are traveling
9. **Reduced Fees to Companies and Government Agencies** – Since attendance of an entire cohort is more-or-less guaranteed over a period of four years, and the use of the facilities of the university is reduced, the university is able to charge reduced fees. This reduction is also supported by the fact that university marketing costs are lower
10. **New Relationships Between Academia, Industry and Government** – An overarching consideration is that cohort programs help to build new relationships between the three participating parties, i.e., academia, industry and government. A very clear domain for such relationships has to do with problem identification and solution across a wide range of engineering disciplines.

## **SUMMARY**

This paper introduces a new and emerging set of processes for graduate engineering education. Aspects of this cohort-based approach have been presented with respect to:

- a. Representative fields of study
- b. Course delivery
- c. Course payments and agreements
- d. The nature of participation

- e. Student benefits
- f. Selected experience, and
- g. Ten points that describe positive features of this new approach

The further acceptance of cohort-based graduate engineering education can easily lead to scenarios that make this a dominant form of education along with the following types of changes:

- a. Various parts of industry attempting to get into the “higher education business”
- b. Reductions in the costs of providing higher education
- c. From the above, an increase in the profitability of providing higher education
- d. Lower tuition costs per student
- e. A change in the mix of public and private higher education institutions, especially in engineering
- f. Stronger connections between industrial companies, government agencies, and universities

The cohort-based approach is believed to be more cost-effective than the current more conventional approach. In situations of this type, the “flow” tends to be in the direction of greater cost-effectiveness, i.e., the more cost-effective solution, although it may take some time to achieve such changes. This is especially true for an overall system that tends to move and change rather slowly.

#### **References**

1. Senge, P., “The Fifth Discipline”, 1990, Doubleday Currency, New York

**Using Internships and Input from Businesses to  
Guide the development of a Computer Technician Course**

Ossama Elhadary  
New York City College of Technology, CUNY

**OSSAMA ELHADARY**

Ossama Elhadary is an assistant professor at the New York City College of Technology, City University of New York. He has a Bachelor's degree in communications and electronics engineering from the faculty of Engineering, Cairo University, as well as an MBA and a Doctorate in Business Administration from the Maastricht School of Management, Netherlands. Dr. Elhadary published a number of papers in local, and international conferences as well as in peer reviewed journals. Dr. Elhadary's research interests include Electronic Commerce, Adoption of technology, project Management, and best practices in management of IT.



# Using Internships and Input from Businesses to Guide the development of a Computer Technician Course

## Abstract

This paper discusses the process of developing a computer technician’s course for the Associate degree program in computer systems. The paper discusses how the faculty perceived a need to develop such a course, and the process used to develop it. Students who had internships were asked to list the activities they did in their internships. And then this list was used to develop a survey that was then sent to department’s advisory board, as well as to the heads of IT in different businesses, and also to a number of IT professionals. In this survey the respondents were asked to rate the skills and knowledge areas they believe are important for an intern or a fresh graduate to have. The results of this survey are then presented and discussed and key areas are highlighted. After the course was developed and taught for the first time, feedback was collected from the students who took the newly offered course. This feedback (will be presented in a future paper) was collected through an online survey that the students were asked to complete after they took their final exams.

## Developing the Course and the survey

All students in the bachelors program in computer systems technology have to take an internship course, in which they are placed as interns in a business and are expected to perform the technical duties assigned for one semester. The feedback received from those businesses seemed to indicate that although the students have strong general technical skills, they seem to lack some key basic skills like installing a memory module, or a hard drive in a defective computer. This motivated the faculty to develop a questionnaire and collect feedback from businesses as to what they need students in an internship to be able to do. The responses collected then guided the development of a computer management course that would be mandatory at the associate level. This course would in turn later help the students perform better during their internship experience.

At the beginning, the faculty in charge believed that this new course will mainly cover a lot of electrical concepts like voltage measurement, circuits, generators. As we started getting feedback from business, it became clear that businesses were seeking other skills. Table 1. shows the results received from 65 IT professionals.

Electrical Course Content Survey				
	Questions	Extremely	Sometimes	Not Needed
1	Measurement of voltage and current, Ohms Law	25	33	42
2	D C Series, Parallel circuits, power. Kirchoff Laws	12	37	52
3	A C circuits, Inductance, Reactance	15	32	53
4	Capacitance, Reactance, Impedance	12	35	53
5	A C Series/Parallel Circuits	18	35	47
6	Generators, Motors, Resonance, Bandwidth	8	55	37
7	Diodes, Rectification, Transistors, Amplifier, logic Gates	15	42	43
8	Mother Board, processors, chip sets	50	27	23
9	Upgrading Memory, Addressing Memory	70	18	12
10	Install and Partition Hard drives. Format and Test Hard Drive with Scandisk	68	23	8

11	Addressing Hard Drives	70	20	10
12	Printer Installation and Diagnostic (Stand alone, Network)	67	20	13
13	Install Windows XP, Manage user's Accounts, Back and restore files in Windows XP	68	23	8
14	Systems Management, Set disk quotas, use of encryption	63	17	20
15	Install Multiple Media Devices: CD/DVD, drives, Explore Windows XP Audio features. Install Dual Monitors in Windows XP, research digital cameras.	58	32	10
16	Download and Install Explorer 7 and Firefox. Configure the IP Address and subnet mask for a PC. Update the Windows and Web browsers	58	30	12
17	Install and Test Ethernet NIC; share resources on a network: Troubleshoot, with TCP/IP utilities.	63	25	12
18	Download and Install Anti-Virus software; personal files; configure the security and privacy level in PC. Delete cookies and passwords	65	27	8
19	I/O Systems, Ports	58	33	8
20	RAID	45	43	12
21	ATA, SATA, SCSI	40	47	13
22	Maintenance and Repair of Laptops	60	27	13
23	Numbering Systems: Binary, Decimal, Hex-Decimal Character Types:	30	43	27

Table 1. Results of Survey

By adding the “extremely”, and “sometimes” responses, one would get the following table (table 2.).

	Questions	%Agree	%Disagree
1	Measurement of voltage and current, Ohms Law	58%	42%
2	D C Series, Parallel circuits, power. Kirchoff Laws	48%	52%
3	A C circuits, Inductance, Reactance	47%	53%
4	Capacitance, Reactance, Impedance	47%	53%
5	A C Series/Parallel Circuits	53%	47%
6	Generators, Motors, Resonance, Bandwidth	63%	37%
7	Diodes, Rectification, Transistors, Amplifier, logic Gates	57%	43%
8	Mother Board, processors, chip sets	77%	23%
9	Upgrading Memory, Addressing Memory	88%	12%
10	Install and Partition Hard drives. Format and Test Hard Drive with Scandisk	92%	8%
11	Addressing Hard Drives	90%	10%
12	Printer Installation and Diagnostic (Stand alone, Network)	87%	13%
13	Install Windows XP, Manage user's Accounts, Back and restore files in Windows XP	92%	8%
14	Systems Management, Set disk quotas, use of encryption	80%	20%
15	Install Multiple Media Devices: CD/DVD, drives, Explore Windows XP Audio features. Install Dual Monitors in Windows XP, research digital cameras.	90%	10%
16	Download and Install Explorer 7 and Firefox. Configure the Ip Address and subnet mask for a PC. Update the Windows and Web browsers	88%	12%
17	Install and Test Ethernet NIC; share resources on a network: Troubleshoot, with TCP/IP utilities.	88%	12%
18	Download and Install Anti-Virus software; personal files; configure the security and privacy level in PC. Delete cookies and passwords	92%	8%
19	I/O Systems, Ports	92%	8%
20	RAID	88%	12%

21	ATA, SATA, SCSI	87%	13%
22	Maintenance and Repair of Laptops	87%	13%
23	Numbering Systems: Binary, Decimal, Hex-Decimal Character Types:	73%	27%

Table 2. Results of Survey with Agree or Disagree

By sorting using the agree percentage, it becomes clear that the following skills/knowledge are highly prized by the surveyed group (see table 3.):

- Download and Install Anti-Virus software; personal files; configure the security and privacy level in PC. Delete cookies and passwords
- Install and Partition Hard drives. Format and Test Hard Drive with Scandisk
- Install Windows XP, Manage user's Accounts, Back and restore files in Windows XP
- I/O Systems, Ports
- Addressing Hard Drives
- Install Multiple Media Devices: CD/DVD, drives, Explore Windows XP Audio features. Install Dual Monitors in Windows XP, research digital cameras.
- Download and Install Explorer 7 and Firefox. Configure the Ip Address and subnet mask for a PC. Update the Windows and Web browsers
- RAID
- Upgrading Memory, Addressing Memory
- Install and test Ethernet NICs; share resources on a network: Troubleshoot, with TCP/IP utilities.
- Maintenance and Repair of Laptops
- Printer Installation and Diagnostic (Stand alone, Network)
- ATA, SATA, SCSI
- Systems Management, Set disk quotas, use of encryption
- Mother Board, processors, chip sets

The least popular skills/knowledge were:

- Generators, Motors, Resonance, Bandwidth
- Measurement of voltage and current, Ohms Law
- Diodes, Rectification, Transistors, Amplifier, logic Gates
- A C Series/Parallel Circuits
- D C Series, Parallel circuits, power. Kirchhoff Laws
- A C circuits, Inductance, Reactance
- Capacitance, Reactance, Impedance

Questions	%Agree	%Disagree
Download and Install Anti-Virus software; personal files; configure the security and privacy level in PC. Delete cookies and passwords	92%	8%
Install and Partition Hard drives. Format and Test Hard Drive with Scandisk	92%	8%
Install Windows XP, Manage user's Accounts, Back and restore files in Windows XP	92%	8%

I/O Systems, Ports	92%	8%
Addressing Hard Drives	90%	10%
Install Multiple Media Devices: CD/DVD, drives, Explore Windows XP Audio features. Install Dual Monitors in Windows XP, research digital cameras.	90%	10%
Download and Install Explorer 7 and Firefox. Configure the Ip Address and subnet mask for a PC. Update the Windows and Web browsers	88%	12%
RAID	88%	12%
Upgrading Memory, Addressing Memory	88%	12%
Install and Test Ethernet NIC; share resources on a network: Troubleshoot, with TCP/IP utilities.	88%	12%
Maintenance and Repair of Laptops	87%	13%
Printer Installation and Diagnostic (Stand alone, Network)	87%	13%
ATA, SATA, SCSI	87%	13%
Systems Management, Set disk quotas, use of encryption	80%	20%
Mother Board, processors, chip sets	77%	23%
Numbering Systems: Binary, Decimal, Hex-Decimal Character Types:	73%	27%
Generators, Motors, Resonance, Bandwidth	63%	37%
Measurement of voltage and current, Ohms Law	58%	42%
Diodes, Rectification, Transistors, Amplifier, logic Gates	57%	43%
A C Series/Parallel Circuits	53%	47%
D C Series, Parallel circuits, power. Kirchhoff Laws	48%	52%
A C circuits, Inductance, Reactance	47%	53%
Capacitance, Reactance, Impedance	47%	53%

Table 3. Results of Survey sorted

### Discussion and conclusion

It is clear from the above results that there is strong agreement on the skills and knowledge that an intern/fresh graduate needs to possess. Notice for example that 92% of respondents believed that knowing how to install an anti-virus program is a needed skill. This and other skills though usually get overlooked while courses are being developed. We seldom teach students how to install a hard drive, or repair a PC, but instead focus on general theoretical concepts. Although those theoretical concepts are important, they usually are of little use to the fresh graduate or to the intern when specific skills are needed to get the job done. There is a need to strike a balance between teaching theoretical knowledge and practical skills that students and fresh graduate can use on their first day on the job.

**LEGO™ Robotics—a tool for integrating K-12 Outreach, Freshman Engineering and Service Learning**

BILL B. ELMORE, Ph.D., P.E.

Holder of the Hunter Henry Chair, an endowed teaching chair, and Associate Director of the Dave Swalm School of Chemical Engineering at Mississippi State University, Bill Elmore is in his seventh year of service to Mississippi State and twenty second year of higher education. His research interests include biotechnology for renewable fuels and chemicals, enzyme-based microreactors and engineering education.

# LEGO<sup>TM</sup> Robotics—a tool for integrating K-12 Outreach, Freshman Engineering and Service Learning

## Abstract

The LEGO<sup>®</sup> NXT robotics system has been employed for the past six years within the Swahn School of Chemical Engineering at Mississippi State as a multifaceted tool in our K-12 outreach program, our freshman chemical engineering classes and as a means for engaging our chemical engineering students in service learning activities. This integration of activities, all surrounding the LEGO<sup>™</sup> Robotics system (coupled to Vernier<sup>®</sup> sensors and probes and “in-house”-designed apparatus) has engaged students at all levels, from middle school through chemical engineering seniors in an exciting, “studio-based” environment. Anecdotal evidence suggests students readily “latching onto” key concepts and various aspects of engineering through this “multi-modal” learning approach. Objectives of this method of program integration include: 1) strengthened recruiting of students to engineering studies, 2) better “visualization” of engineering concepts among chemical engineering freshmen and 3) a stronger sense of the need for life-long learning and community service among our engineering undergraduates.

The use of LEGO<sup>™</sup> Robotics serves as a means for increasing student interest in STEM topics through highly visual, active learning. Among the benefits realized with this system are 1) the use of a platform familiar to many students (i.e. LEGO building components); 2) “seamless” integration of hardware and software systems (i.e. all the parts “fit”); and, 3) minimal startup delays resulting in easily understood symbolic software package and hardware components that facilitate “rapid prototyping” of devices (students can quickly design and build projects from their imaginations).

This paper reports on the current state of this effort and provides some evidence for its success. We also report on the efforts’ strengths, weaknesses and planned improvements.

## Introduction

### *Scene 1*

The room is filled with noise, as a dozen or more middle school-aged Girl Scouts in one corner try to “scream” their racing robots across the finish line, driven forward by programmed responses to microphone inputs; while, in another room a second group is quietly experimenting with the effects of environmental pollution and deforestation, as their robotic “creatures” respond with increasing distress to the removal of protective plant life.

Elsewhere, another team investigates a LEGO<sup>™</sup> robot’s ability to negotiate an incline when given various surface treatments. The engineering undergraduates coaching the Scouts through



the morning's events are all smiles and obviously proud of the Scout's accomplishments as they rotate through the morning's merit badge stations.

### *Scene II*

We peer into a classroom early one Saturday, and see a group of middle school students intently focused on the morning's robotic challenge while their freshmen engineering coaches stand at



the ready for the construction or programming questions that may arise. The quietness and focus of the paired teams is as notable as the enthusiastic shouts and laughter of those in the first scene.

The experiments with various gear ratios, speed and wheel circumference momentarily induce a few yawns among the participants, but the coming contest of "robot football" keeps heads thinking and LEGO® parts flying to produce a "star player" by the time of the competition.

### *Scene III*

The class of 60 perks up noticeably when I cease my instruction on using Microsoft Excel® for experimental data management and wheel in carts loaded with LEGO® robotic kits, telling everyone to get into their teams and begin their first team design challenge. Initially, I spend a good bit of time mentoring teams and working to help balance those *legowizards* (and their tendency to dominate the project) with those more hesitant to step out into unfamiliar territory. Within a week, I have to caution some to not let their calculus, chemistry and physics "slide" while spending an inordinate amount of time outside of class on their projects. Team dynamics are continuously improving and, through shared *team leader*, *cheerleader* and *data keeper* roles, I can observe obvious growth of many individuals in their confidence levels and abilities to be a team player. By the end of the semester, projects range from a "processing station" to model wet etching of silk on wafers to a multi-tank system for producing a "chemical product" at a constant rate and quality.



Over the last six years, each of these "real-life" scenarios has played repeatedly in sections of CHE 2213 Freshmen Chemical Engineering Problem Analysis and through many students' participation in our K-12 outreach effort.

Uniquely positioned through my freshman teaching assignment (i.e. CHE 1101 Freshman Seminar each fall and CHE 2213 Problem Analysis each spring) and service as Faculty Advisor of our heavily service-oriented American Institute of Chemical Engineers (AIChE) student chapter, I have been able to team up with my students to develop a program for engaging both freshmen chemical engineering majors and K-12 students in active learning through design.

oriented projects with LEGO® robotics, Vernier® sensor technology and a “supporting cast” of pipes, pumps, tubing, gears, etc.

### Theoretical Framework

*“Learning about things does not enable students to acquire the abilities and understanding they will need for the twenty-first century. We need new pedagogies of engagement that will turn out the kinds of resourceful, engaged workers and citizens that America now requires.”*

Russ Edgerton, former education officer for the Pew Charitable Trusts (Smith et al., 2005)



#### Hands-on education

The concept of “pedagogies of engagement” increasingly finds expression at all levels of education, and, in some forms, is described variously as “hands-on” education<sup>1</sup>, “problem-based”<sup>24</sup> or “project-based” learning<sup>25</sup>. Such approaches provide strong links between science and mathematics concepts and real-world problems as students “construct” new content knowledge while investigating a problem through a physical system (i.e. actual physical elements used to analyze a problem and synthesize potential solutions)<sup>2</sup>.

The use of robotics to actively engage students in learning has a strong foundation in K-20 education.<sup>6</sup> Robotics applications are used in a variety of higher education settings across numerous disciplines including various engineering disciplines<sup>7,16</sup> and at various levels from freshman through senior classification.<sup>11-12</sup> Studies of courses in which robotics is featured prominently have shown positive results from such applications.<sup>11</sup> Likewise, robotics problem-based learning activities have been shown to be a valuable asset to K-12 classrooms useful in teaching not only STEM-related subjects<sup>11,17</sup> but even topics in biology<sup>12</sup> and values education.<sup>18</sup>

Robotics technology enables teachers to elicit creativity and critical thinking from students by drawing on students’ curiosity towards unknown, yet approachable physical systems.<sup>15,16,18</sup>

In a pivotal report on middle school education, *Turning Points: Preparing American Youth for the 21<sup>st</sup> Century*, one recommendation stated “Middle grades schools should transmit a core of common, substantial knowledge to all students in ways that foster curiosity, problem solving and critical thinking<sup>19</sup>. We believe the use of robotics in our outreach program has helped to raise the level of curiosity among the K-12 groups we visit.



A further benefit is being realized through the Swarth School of Chemical Engineering’s freshman engineering and K-12 outreach program in that a significant service-learning component has become a natural outgrowth of this effort to bring robotics into the classroom. The involvement of colleges in K-12 outreach has a long-standing tradition among higher education institutions and, particularly, colleges of engineering, as an ever-increasing need for “academic intervention” has arisen with the decline in student preparation in STEM subjects pre-requisite to undertaking engineering study<sup>20,21</sup>. Such service learning activities can contribute to increased collaboration across the divide that often separates the engineering and science and K-12 educational cultures<sup>22</sup>. A “service-oriented” culture can also enrich the educational experience of engineering undergraduates. Possessing inherent strengths through a progression toward becoming ever more highly-educated, they can grow in their awareness of the



responsibilities to use this preparation to become informed leaders and "service-active citizens" in their respective communities.

### The Evolution of our Program

The Swain School of Chemical Engineering K-12 outreach program has grown, in part, out of my own personal experience engaging my children in STEM-based activities during their middle school years. In particular, our involvement with the highly energized *First Lego League* competitions contributed to my daughter's choice to study mechanical engineering. It further led to the germination of an idea about using the LEGO<sup>®</sup> robotics system to creatively introduce practical engineering concepts to my chemical engineering freshmen.



Beginning in 2005, I brought LEGO<sup>®</sup> robotics into CHE 2213 Chemical Engineering Problem Analysis (i.e. *Analysis*) in an attempt to evaluate the course material and better motivate student learning. Historically noted in teaching various Microsoft Excel<sup>®</sup> and Visual Basic techniques, *Analysis* focused on preparing students for the extensive use of these tools in later courses and in the chemical process industries. I personally found the method of working through spreadsheets

in "real time" tedious and stifling to class dynamics. "Now class, if you will notice, as I execute this formula in cell Z2149 how it changes the results in cells A45, D15 and R73..." (you get the idea). I considered a better approach—putting these tools into an "as needed" context with hands-on engineering design problems.

Simultaneously, as the faculty advisor for our student chapter of the American Institute of Chemical Engineers (AICHE), I launched a service-learning initiative as a means of strengthening students' broader educational experience and as a way to draw more prospective K-12 students toward considering careers in engineering.

The marriage of our service-learning activities and the use of LEGO<sup>®</sup> robotics became an inevitable link over several semesters as chemical engineering students' familiarity with the robotics kits grew and naturally integrated into developing interesting, hands-on activities for our K-12 outreach.



### Program Structure and Activities

Over the five intervening years since the introduction of robotics technology to the chemical engineering analysis course and the current use of this technology in our K-12 outreach program, we have led a number of activities including

- Boy Scouts and Girl Scouts half-day workshops where Scouts can earn multiple STEM-oriented merit badges
- A five-week series of half-day middle school robotics building sessions for grades 4-6
- Multiple school site visits
- After school and weekend community programs

## Strength and Challenge

To many, building and operating robots looks interesting and fun, but the task of doing this can be daunting. Likewise, the underlying principles supporting the “How?”, “Why?” and “What for?” may seem elusive to many. Through our numerous activities using the robotics kits we have experienced firsthand how quickly students can learn to assemble and operate this system.

A crucial element to the introduction of any technology to the classroom is the utility of the technology. LEGO® robotics kits are designed with engineering precision allowing users to quickly and repeatedly build prototypes of projects conceived and designed by students. Added capabilities are gained by combining the LEGO robotics technology with Vernier sensor technology—facilitating the design of experiments that not only allow the collection of data from an experiment, but allow students to program the robot to respond to the experiment with an action that accomplishes a task.



For example, one student team designed a “battling machine”; another designed a “soda dispenser” that would pour a precise amount of soft drink into a waiting cup. This “whole process” approach to STEM subjects brings learning full circle by showing the learner how the result from a given experiment can be used to accomplish a real world task. From a chemical engineering perspective, some of my freshman chemical engineering student teams have designed a system to measure and maintain tank level with inflowing and outflowing streams of water (a commonly observed phenomenon in any chemical processing plant). Using the LEGO robotics software (we stayed on a National Instruments LabVIEW platform) the LEGO robotics microprocessor kit set to control valve settings in response to the

sensor-detected tank liquid level. Vernier sensors are available over a broad range of subjects in the areas of physics, biology and chemistry (e.g. accelerometers, carbon dioxide and oxygen detectors, pH and temperature sensors). These sensors readily interface with the LEGO robotics kits to allow students to design real world processes spanning an equally broad range of engineering topics.

## Conclusion

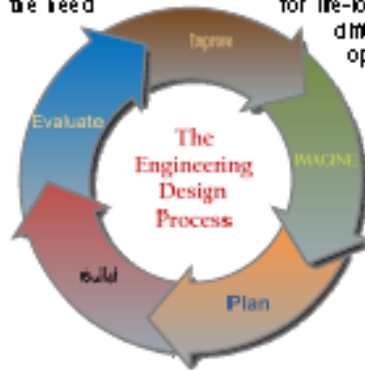
Teachers, students and administrators alike have responded enthusiastically to our outreach activities—many asking us to enable them to bring such advanced technology and training to their classrooms. Misses happen regularly in or near the bottom of most statistical measures regarding educational expenditures per pupil. For many schools, this type of robotics/sensing technology is out of reach financially. Yet, we believe that sustained contact with schools through our outreach program can contribute to increasing the acclimation of students to engineering and science career preparation by combining sustained coaching and modeling with an integrated technology and an equally integrated curriculum spanning STEM subjects.



As with any K-12 Outreach, there are challenges. The lack of parallel technology in many classrooms can leave students merely “teased” with the allure of such intriguing learning opportunities and no means by which to continue this problem-based learning approach in the more sustained classroom environment. That is, how can we assure a lingering benefit to students once we have “loaded the toy box and driven away”? While this question poses a major dilemma for making a lasting, systemic change, we believe, that the effort to inject undergraduate engineering enthusiasm and experience with K-12 students is nonetheless beneficial. We all have heard (or perhaps personally experienced) that momentary contact where a seemingly small life action made had a major effect in life’s direction. Such is our hope with this approach to K-12 outreach.

The implementation of this program is necessarily engaging our chemical engineering undergraduates in regular service-learning opportunities—opportunities we believe contribute substantially to the quality of the need

for life-long learning, and using their engineering education for making a difference in the lives of others. By approaching K-12 students with opportunities to creatively understand and apply engineering design, we believe their potential for preparing, presenting and performing as future engineers is greatly enhanced.



## References

1. Johnson, S. H., Luyben, W. L. and Talhelm, D. L., "Undergraduate Interdisciplinary Controls Laboratory", *Journal of Engineering Education*, 84, (2), pp.133- 136, (April 1995).
2. Hmelo, C. E.; *Problem-based Learning: Development of knowledge and reasoning strategies*, in Proceedings of the 17<sup>th</sup> Annual Conference of the Cognitive Science Society; Pittsburgh, PA; 1995; pp. 404-408.
3. Yu, Chang Y. and David T. Shaw; *Fostering Creativity and Innovation in Engineering Students*; 2006 International Mechanical Eng. Edu. Conference; Beijing, China; March 31-April 4, 2006; [www.asme.org/Education/College/2006\\_Proceedings.cfm](http://www.asme.org/Education/College/2006_Proceedings.cfm)
4. Barron, B. J., D. L. Schwartz, N. J. Wye; A. Moore, A. Petrosino, L. Zech, J. D. Bransford, and The Cognition and Technology Group at Vanderbilt; *Doing With Understanding: Lessons from Research on Problem- and Project-based Learning*; The Journal of the Learning Sciences; Vol. 7, No. 3/4, 1998, pp.271-311.
5. Beer, R. D., H. J. Chiel and R. F. Drushel; *Using Autonomous Robotics to Teach Science and Engineering*; Communications of the ACM; Vol. 42, No. 6; June 1999; pp. 85-92.
6. Erwin, Ben; Martha Cyr; and Chris Rogers; *LEGO Engineering and RoboLab: Teaching Engineering and LabVIEW from Kindergarten to Graduate School*; [http://www.ni.com/pdf/academicus/journals/ajee\\_05.pdf](http://www.ni.com/pdf/academicus/journals/ajee_05.pdf)
7. Rosenblatt, M. and H. Choset; *Designing and Implementing Hands-On Robotics Labs*; IEEE Intelligent Systems, Nov/Dec 2000; pp. 32-39.
8. Williams, A. B.; *The Qualitative Impact of Using LEGO Mindstorms Robots to Teach Computer Engineering* IEEE Transactions on Education; Vol. 46, No. 1; February 2003; p. 206.
9. Elmore, Bill B.; *Using LEGO MindstormsTM to teach Chemical Engineering Problem Solving* presented at 2007 AIChE national meeting, Salt Lake City, UT, November, 2007.
10. Elmore, Bill B. *A freshman design course using LEGO<sup>®</sup> NXT Robotics*, **Chemical Engineering Education**, Spring 2011, 45:2, pp. 86-92
11. Wang, Eric; *Teaching Freshmen Design Creativity and Programming with LEGOs and LabView*; presented at the 31<sup>st</sup> ASEE/IEEE Frontiers in Education Conference; October 10-13, 2001; Reno, NV; Session F3G; pp. 11-15.

12. Moor, S. S. and P. R. Piergiovanni; *Using Lego-based Classroom Laboratory Kits for Learning Process Control*; presented at the 2003 American Institute for Chemical Engineers (AIChE) Annual Meeting; San Francisco, CA; Session 348d; November, 2003.
13. Pomalaza-Raez, C. and B. H. Groff; *Retention 101: Where Robots Go... Students Follow*; J. Eng. Edu; January 2003; pp. 1-6.
14. Gerab, L. J., M. Gallagher, and J. Golder; *An Engineering Linkage to K-12 Teachers*; Session 3453; Proceedings of the 2001 American Society for Engineering Education (ASEE) Annual Conference; 2001.
15. Miglino, O., H.H. Lund, M. Cardaci; *Robotics as an Educational Tool*; J. of Interactive Learning Research; V. 10, No. 1; 1999; pp. 25-47.
16. Naghdaudhuri, A., G. Singh, M. Kaur, and S. George; *LEGO Robotics Products Boost Student Creativity in Pre-College Programs at UMES*; presented at the 32<sup>nd</sup> ASEE/IEEE Frontiers in Education Conference; Session S4D; Nov. 6-9, 2002; Boston, MA.
17. Lund, H. H. and L. Pagliarini; *RoboCup Jr. with LEGO Mindstorms*; Proceedings of the 2000 IEEE International Conference on Robotics and Automation; San Francisco, CA; April, 2000; pp. 813-819.
18. Bers, M. U., I. Ponte, C. Juelich, A. Viera and J. Schenker; *Teachers as Designers: Integrating Robotics in Early Childhood Education*; Information Technology in Childhood Education Annual; 2002; pp. 123-145.
19. Jackson, A. W. and G. A. Davis; *Turning Points 2000: Educating Adolescents in the 21<sup>st</sup> Century*; Teacher College Press; Williston, VT; 2000; p. 2.
20. Jeffers, A. T.; A. G. Saffernan; and S. I. Saffernan; *Understanding K-12 Engineering Outreach Programs*; J. Professional Issues in Engineering Education and Practice; April 2004, pp. 95-106.
21. S. H. Billig; *Research on K-12 School Based Service-Learning: The Evidence Builds*; Phi Delta Kappan; May 2000; pp658-664.
22. K. Carr; *Building Bridges and Crossing Barriers: Using Service Learning to Overcome Cultural Barriers in Collaboration Between Science and Education Departments.*; School Science and Mathematics: W 102(6); October 2002; pp. 285-298.

## **Global Engineering: Taking the Engineering Classroom to the Real World**

CARL A. ERIKSON, JR.  
Department of Engineering  
Messiah College  
Grantham, PA 17027

CARL A. ERIKSON, JR.

Professor Erikson is an Assistant Professor of Engineering. He obtained his BSEE degree from Rutgers University in 1969 and his MSEE degree from Purdue University in 1971. He had worked in industry for 18 years before coming to Messiah College to help start the new BSE program in 1989. He has authored many articles on microelectronic processing and components. He has given numerous presentations to industry, colleges, professional societies, and civic organizations. Since 1990 Mr. Erikson has been interested in and promoting the concept of Appropriate Technology in the Third World as well as in urban areas around the world. He has worked in Kenya, Bolivia, Venezuela, and Guatemala. As part of the Collaboratory, Professor Erikson is Energy Group Advisor. The Energy Group is responsible for solar photovoltaics, solar hot water, biofuels, and wind energy projects.

# **Global Engineering: Taking the Engineering Classroom to the Real World**

## **Abstract**

This paper includes an update on previous papers/presentations at the Mid-Atlantic Chapter of ASEE conferences given by the author on the Integrated Projects Curriculum (IPC) and the Collaboratory for Strategic Partnerships and Applied Research (Collab). The IPC is a service learning base course of study in the Department of Engineering at Messiah College while under the umbrella of the Collab, under the School of Science, Engineering, and Health at the college. IPC has been operating and evolving over its 4 or 5 year history. Over 100 engineering students are involved in studying, researching, designing, prototyping, and implementing projects. Six major project areas include biomedical, communication, disability resources, energy, transportation, and water. Students have recently completed projects in Honduras, Nicaragua, Burkina Faso, Zimbabwe, and Zambia.

The study and use of Appropriate Technology principles in the classroom and laboratories allow the students to consider not only technology issues in the Third World but also non-technical issues of social, economic, cultural, and political concerns. The service learning pedagogical approach provides the content, engagement, and reflection components to achieve the successful educational goals of the Department.

## **Introduction**

This paper is an update of two past Mid-Atlantic ASEE Conferences papers [1,2] In addition several other papers on the Integrated Projects Curriculum (IPC) and the Collaboratory for Strategic Partnerships and Applied Research ( Collab ) have been written for other national organizations' conferences such as ASA [3] and AAC&U [4] as well as other regional conferences such as the St. Lawrence Chapter of ASEE [5]. These papers give most of the background leading up to the implementation of the Collab in 2004 and the IPC in 2007. In summary, the Collab is a student-run center on campus for all disciplines while the IPC is a Department of Engineering initiative for its students. Both the Collab and IPC “add value to classroom learning by enabling participants to apply academic knowledge and live out their Christian faith through imaginative, hands-on problem solving that meets needs brought to us by Christian mission and relief and development organizations and businesses”[6]. Some of the international clients have included World Vision, SIM(Serving in Missions), MCC(Mennonite Central Committee), CURE International, PACTEC(Partners in Technology International), and MAF(Missionary Aviation Fellowship). Local organizations and businesses are also an important source of projects for the students and include Project SHARE, Paxton Ministries, Joshua Farm, and Silence of Mary Home.

## **Classroom instruction**

Traditional course work continues as the essential backbone of the engineering curriculum, i.e., engineering fundamentals in the five specific concentrations [Biomedical, Computer, Electrical, Environmental, and Mechanical] within the BSE program are taught in the classroom. In addition, for all concentrations the IPC requirements allow the faculty to integrate cognitive, affective and behavioral education through a two course seminar series and five project courses starting in the second semester of the sophomore year. The IPC curriculum builds on service-learning pedagogy including academic content, project engagement, and reflection. Essentials elements of this integration include the shared leadership concept, effective use of

documentation and logbooks, how to do meaningful research, working on teams, and many other skills needed for future professional work.

Throughout the students' four years in the engineering curriculum, the use of appropriate technology (AT) principles are taught and implemented. One useful definition of AT is as follows:

Appropriate technologies are local, self-help, self-reliant technologies that local people themselves choose, which they can understand, maintain, and repair. They are generally simple, capital saving, labor enhancing, and culturally acceptable. Ecologically, appropriate technologies are environmentally sustainable, as much as possible using renewable energy, and limiting atmospheric, chemical, and solid waste pollution. [7]

Because most students are privileged living in the USA, non-technical issues such as the role of culture, religion, socio-economics, and worldviews are continually stressed as part of engineering solutions to the real needs of the world. Students research, design, build, and test prototypes in consultation with clients within a specific culture, using the resources and local skills of the indigenous artisans that they are working with. Some projects may take one academic year to complete while many take several years before implementation is completed in the field.

Presently there are six groups in IPC which include Biomedical, Communications, Disability Resources, Energy, Transportation, and Water. TheCollab has other groups to include Education, Micro-economic Development, Staff, and Sustainability. Each group's orientation includes the history of the group, training on specific equipment, what documentation procedures and requirements are necessary, how to become effective team members, etc.

### **Actual experiences**

Several recently completed projects demonstrate the success of the IPC to educate the engineering students as well as meet the needs of various peoples groups around the world.

#### **Water group**

Potable water is an essential commodity for a healthy community any place around the world. One important fundamental that the students in the Water Group learn about is the use of different water purification techniques to fit the particular need of a community. Three specific water purification techniques have led to successful projects to include implementation of two ultra-violet systems in Guatemala, a reverse osmosis system in Honduras, and an ozonization system in Nicaragua.

#### **Disability resources group**

In Mahadaga, Burkina Faso, West Africa, students have developed improvements to both hand-powered and electric powered tricycles for the disabled. The local artisans are "taught" improved manufacturing techniques by students who have successfully designed, built, and tested prototypes in the USA before sharing the results with the artisans. Key manufacturing principles of minimizing welding by proper bending of structural components and strengthening weight bearing design have demonstrated to the local artisans ways to improve the tricycles' manufacturability.

#### **Energy group**

The reliability of an electrical energy supply as well as the energy's cost are problematic in many communities around the world. Solar energy is readily available for both electrical needs as well as for delivering hot water. Several solar hot water systems have been implemented by IPC students for the Theological College of Zimbabwe for use in its students' dormitories. Three solar photovoltaic systems have been implemented in Madahaga, Burkina Faso, for lighting a maternity clinic, for pumping well water, and for powering several homes.



Several other IPC groups are working on projects under development but have not been implemented in the field as yet. They include the following:

#### Transportation group

The Light Sport Aircraft (LSA) has been under development for many years. The LSA is to be used for short take-offs and landings (less than 300 feet) for emergency use or in rugged terrain applications. Students have worked on frame/body design, engine design, landing gear design, and a folding wing design. The first prototype should be completed within the next year.

#### Communications group

Within the Communications Group, students have been developing an assistive communication technology project called the Wireless Enabled Remote Co-presence (WERC) project. Several prototypes of “WERCware” have been demonstrated allowing “people with Asperger Syndrome to work and live more independently by connecting them to an off-site social coach who can provide real-time support”. [6]

#### Biomedical group

The Biomedical Group is the newest group in the IPC. Recently the students have started a project in developing a low cost oxygen concentration generator for use in hospitals in the Third World.

### Conclusions

The service learning pedagogy of integrating projects into the engineering curriculum is both challenging and beneficial to students and faculty, providing both academic credit for students and load credit for faculty. Real world constraints and issues, both technical and non-technical, allow future engineers to know what to expect as they enter the job market, taking classroom theory into actual practice.

Time management skills, cost and resource allocations, client interface/communications, leadership development, and effective documentation are but a few learning/growing experiences that the students develop by working on these real world projects.

Even though IPC is still evolving, it is an innovative curriculum that integrates engineering knowledge, project engagement, and meaningful reflection on how and why one uses his/her talents for the “benefit of humankind”.

### Bibliography

1] “Integrated Projects Curriculum: Opportunities for Hands-On Alternative Energy Projects”, given at the Mid-Atlantic Chapter ASEE Fall Conference, October 2009.

2] “Project Team and Advisor Characteristics”, given at the Mid-Atlantic Chapter ASEE Fall Conference, November 2007.

3] “Appropriate Technology in the Department of Engineering at Messiah College”, ASA National Conference, Messiah College, August 2005.

4] “Integrated Projects Curriculum”, AAC&U Conference, Denver, October 2005.

5] “Service Learning Projects “For the Benefit of Humankind”: The Societal, Global, and Professional Impacts of the 21<sup>st</sup> Century Engineer”, 2005 ASEE St. Lawrence Section Conference, 2005.

6] taken from a Collaboratory pamphlet produced in 2010.

7] taken from Appropriate Technology: A Focus for the Nineties edited by Robert W. Stevens, page ix, ITDG of North America, 1991.

### **SECTION 3**

**Engineers do it First**

Scott Foerster,  
Assistant Professor of Engineering,  
Howard Community College

*Engineers do it First* by Scott Fowles, Assistant Professor of Engineering, Howard Community College

Abstract "Introduction to Engineering" courses introduce a university's unique programs, projects and tools. Ethics and privileges such as 24 hour by 7 access to tools, materials and rooms are negotiated. Community Colleges don't have the resources, graders, graduate assistants, and multiple professors teaching the course. This paper lists the problems of teaching "Introduction to Engineering" at a Community College. It argues that truly open ended projects can be taught to freshman. It proposes an external assessment process as well as internal grading system. It is inspired by DIY, maker/maker spaces, wikibooks, and wikiversity. It starts from a new narrative of playing, doing things first, design and problem solving. "Introduction to Engineering" is where students learn "Engineers do it First"

#### Outline

- [Narrative Problem](#)
- [Freshman Problem](#)
- [Open Ended Project Problem](#)
- [Course Management Problem](#)
- [Internal Grading](#)
- [External Assessment](#)
- [What's Next?](#)

#### *The Narrative Problem*

The current Engineering narratives are "Applied Science", "Solve Problems", "Make Things", "Design" and "Engineers help shape the Future." Do these narratives work? How many kids say they want to be an engineer? Who is they as in "They just created a new wire with carbon and no metal or copper." Only at community colleges do students decide an engineering major that can't pass an algebra placement test, want to move knobs up and down in a solid stubb, already have some other undergraduate degree (like physics, or architecture), or are challenged in some way.

Engineering is like a business to business world (B2B) where both clients and customers are other engineers. Doctors and lawyers interface with the public every day. The public has a strong narrative associated with most occupations. Engineering draws a blank.

Why aren't current narratives working? Look at the trough. The B2B world provides no ability to test narratives. Retaining freshman interested in engineering at four year schools is a different objective than explaining engineering to the public.

#### K-12 "Trust Science" Narrative Dominance

The US military preferred to work with physicists rather than engineers during WWII. Engineers belonged to clubs, not societies. They were either super techs or tech managers. "Art and Practice" dominated the engineering profession. A deliberate decision to begin promoting Engineering Science was made during the creation of the National Science Foundation (NSF). This has been a success. Engineering undergrads now drop out to become physicists. Less prestigious colleges offer Physics instead of Engineering. Physics is cheaper, easier to staff and can simulate the efficient assessment demands of modern accountability.

The K-12 "trust science" narrative inspires education that discourages magic, establishes an understandable science and promotes the "scientific process." This narrative does create a public that votes for a pure research infrastructure. Changing this would be dangerous. The gap between a needed "creating scientists" narrative and the K-12 "trusting science" narrative has now fallen on the shoulders of engineering.

## The Technology Narrative

Engineers face a real danger of becoming technologists. Engineering Technology programs fill a real need. They provide a career pathway between technology and engineering. They establish mutual respect. Unfortunately, one of engineering narratives blur the engineering/technician distinction.

To fight this, most colleges are either focused on engineering science or engineering technology. K-12 and community colleges have both. Most of the attribution problems between community colleges and four-year institutions exist because of technology narrative problems. Four-year institutions believe K-12 and community colleges don't implement the "create scientist" narrative, have to train technicians and this can not include only supporting engineering science.

What is the technology narrative? The industrial arts, technician, technologist, certification, apprentice, master occupations can all be lumped into one narrative. "Do something for 15 years." Become an expert. Experience creates expertise. This is not an engineering or "creating scientist" narrative.

### Engineers do it first

The design requirements for an engineering narrative are: put "doing it" in the right context, sandwich between "create scientist" and "technology" narratives, fit on a bumper sticker, a one typical guide for all engineering courses, and foster engineering projects.

The "Do it First" narrative emerged while sinking into the ugliness of "Design" and "Solve problems" narratives. It is the truth for students suffering through process without relevance.

### What is "it"?

- It extends and matures through the group play to eight "expiring."
- It values ignorance as much as experience and expertise.
- It creates inspiration that can't happen in education where the teacher says "Be like me."
- It sets the stage for an emphasis on repeatability and documentation.
- It matures into design and engineering problem solving versus technical problem solving.
- It can lead to the scientific narrative of theories, instruments and experiments.

Asking the question "Who gets to do it first?" establishes the currency of engineering: RESPECT.

The full narrative is Play → Do it First → Design → Solve Problems.

### *The Freshman Problem*

#### Respect versus Expertise and Experience

Freshman engineers are crippled by the K-12 narrative: "experience creates expertise and ultimately respect" Today, first hand, direct experience is expensive. Expertise is now routinely gained from simulation. Ignorance can have as much value as expertise. The order has been reversed: demonstrate Respect, build some Expertise and then reward with direct Experience. The currency freshman engineers need to be taught is Respect.

#### Push off versus Pull Up the Educational Mountain (expertise)

K-12 equates instructor expertise. But it cripples the self-motivated self-learning that everyone is naturally born with. For example, a freshman team is tasked with building a toy robot boat. One person decides to design the hull. They feel their first task is to find a hull design expert or become an expert.

Many engineering programs combat this with "scaffolding" which merely reinforces education expertise rather than challenge it. Scaffolding homogenizes, puts constraints on creativity and provides no other skills other than exhaust yourself to do your best.

What is the alternative? Meet the world as it presents itself. There are toy boats. There are soda bottles. Pick one. Put it in the water. Attach the motors and radio controls. Create an on time, functional, attractive deliverable. Earn engineering respect. Modern adventures are junk pile explorations. Let the project dictate the content.

Engineering education must become comfortable with pushing students off the mountain into unknown waters (to both student and teacher) and learning to swim on their own. We have to teach against the K-12 archetypes rather than leverage them. We have to never know harder and never know than our students. We have to risk doing the project ourselves. We must wear the client/project manager hat, not the student engineer hat.

### My problem versus atoms (timidity)

How does an engineer gain the respect that will attract business when nobody else knows? If the engineer calls the known personal lack of knowledge a "problem", there will be no business. Engineering will not happen. The simple answer is to focus on service. "I am going to serve you by building a radio controlled model boat on time, that works and it will look gorgeous."

There are three paths an engineer walks. One is the path of exercising expertise. This is the public face of engineering and it unfortunately fits the K-12 education model. But it is not the focus of engineering. The second path is exploration, learning about something that will improve the species. The third is learning what one doesn't know, something new to the engineer.

For an engineer, expertise is a fleeting, momentary consequence that disappears as soon as the next unknown is tackled and technicians take over. Expertise is not the goal. Service is the goal.

The typical question freshman engineers are asked (What type of engineer do you want to be?) plays into the wrong archetype. Almost every engineer will describe their life by their role in a project (sales, support, design, testing, implementation, prototype, management). The non-engineering public expects expertise demonstrations. Do we want to graduate engineering students that will only look for jobs in the fields they have some educational derived expertise ... Statics = Bridge Building?

### Big versus little problems (scope)

Why introduce large project issues into freshman engineering courses? Most intro engineering texts describe big problems and then assign students a project such as "Here is a bunch of parts: build a model car." Students cannot connect the small problems they encounter to the big ones discussed.

K-12 buses react to bus that start with "I have a problem organizing", "I have a problem focusing", "I have a lack of expertise." None of these are engineering problems. Engineering problems are outside of our minds. They are stumbled upon. Some are small, some grow large and enlighten everyone.

K-12 doesn't like problems. Problems exist only paired to solutions. The seduction of solutions, the impartiality of problems, the brainstorming of possible solutions, and the rationalization of investigative techniques. Most minimize the pain and frustration a problem triggers. Freshman avoid problems instead of finding engineering inspiration in them.

Engineering problems seeds are discovered by individuals. Most remain small and are solved immediately. Some grow. Some explode to many small problems. Documenting the process, collecting justifications, describing attempts and failure symptoms results in an engineering mind. Trying to fit anything into a big problem design mold confuses students.

### Feeling success

Many community college engineering students have experienced the narrowing failure. They have not experienced motivational confidence building success.

Most introduction to engineering classes have a single project that all students do. Even large colleges with 700 students, force them all into one project. Some officially label the whole experience a competition. Competition produces success for a handful and failure for most. This supposedly models competition in the real world. In reality it is discouraging to all but the best and brightest.

The alternative is many small different projects, three team members, smaller scopes, lower expectations, and smaller successes with enormous celebrations. The problem is not multiple choice questions or tests. The problem is that we only celebrate multiple choice question test success. Celebrations create Respect. Can we organize engineering departments to celebrate the design of a screw?

### Failure Respect

The hardest part of engineering is helping students find inspiration in frustration and problems. The second hardest thing is teaching students how to generate Respect in the face of failure. The secret is teaching students how to document failure.

The goal of Failure Can't be Done documentation is to establish enough Respect that others don't attempt to repeat the failure. Typically this requires exhaustion of Internet searches, time and inspiration. Any uncertainty or timidity will attract more engineering. All respect will be lost.

### Like and Timidity

Festivals are often motivated by social connections. Without carefully describing engineering team member relationships, most teams fall apart. The need to create social connections may create priorities that compete with the intellectual goals. Stories must be told of Respect between everyone agrees on everything, and stories must be told of Respect gained by working through differences.

Students will try to justify undeclared solutions by the K-12 efficiency archetype rather than acknowledge the like and be liked seduction. It is necessary to look for problems rather than gloss over them, to slow down and reword the problem different ways without solution, to sink into the frustration's despair and find inspiration there. Teams don't do this. Individuals do.

Most team activity is individual activity. The team aspect is comparing, fitting, testing and then re-gathering how to split up again. Separating like from I requires being accountable and transparent. It is one of the most important engineering ethics and respect issues. The maturing of festivals has to begin with targeting the like and be liked timidity dance.

### Slackers

Engineering education grading one makes those that can concentrate/learn from books and penalizes those that learn verbally and can't think complex topics to sound bytes. This is expressed by the saying "A student's become instructor, B students end up working for C students." This is scary to community college students who will never transfer with a C.

Slacking issues appear immediately. At least half of all K-12 students learn from the class collective mind rather than from the teacher. Unique projects expose this parasitical ingenuity. This has to be spun positively. Turn slacks into communication. Talk about the other danger of "hard to work with." Identify and celebrate communication success. Equate communication with documentation success. Both are needed on an engineering team.

This issue is not solved by Myers Briggs tests or even Johnson O'Connor like rules. The conventional approach that creates slacks and the hard to work with has to be addressed early. Otherwise students will immediately begin labelling themselves and drop out of engineering.

### *The Open Ended Project Problem*

The gray area between Open Ended and Closed Projects has been thoroughly explored and named. But there is still a lot of confusion. The definition used here is: students choose among a variety of new/different projects, projects are never finished (unless improvement), and instructors grade form and celebrate success.

### Inspiration versus Content

Education research has shown that students walk away from open ended problems with more inspiration and less content. It is a variable problem that students don't value the inspiration until after graduation. Engineering is the when content and inspiration emerge together. K-12, content, time, and dialogue discussions are important. But they discourage inspiration. The comparisons limited by competition inspire only a few. Engineering has to be about adding back the inspiration, not controlling K-12 expectations.

Engineering project grading typically slips into K-12 expectations. Experts lecture and assign some work on content that seems random to the students or supports the single project that everyone does. Neither accomplishes the inspiration objectives of an open ended project.

This is done because there is no model for grading inspiration. The next section proposes how to do this easily. Inspiration can be graded just like in the engineering workplace: through project management accountability, documentation and presentations.

### Project Management versus Content

The freshman engineering class needs to glue up content. Instructors should not present themselves as experts. Freshman need to discover content themselves. They need to be forced to learn on their own. Instructors should point to options like a project manager.

The project management approach focuses on documentation, transparency and accountability. The documentation requirement creates a course management issue similar to engineering corporations. The goal is to hold individuals accountable and celebrate team success. Documentation should start off personal, and then move to team presentations and team documentation. Personal success can be withheld until the team's work is done.

### Materials and Facilities

Projects need space. Space is normally created by demonstrating need. Large projects that create bits of noise, dust, and debris can justify facilities.

Facilities can only be built slowly. External money and grants normally increase existing success. They don't finance startup programs. Facilities have to be built slowly over time from what students leave behind, from junk and boards of other departments.

Open ended projects don't fit the K-12 efficiency expectations of lesson plans, materials lists and ordering of materials during the summer to the entire year. Efficiency expectations kill most open ended projects in a term and cause while elephant in the room. For example, open ended projects always involve searches for materials. Ordering materials requires a justification, a problem statement and confidence respected by the instructor. Ordering materials is a honor form of success that is missed if all materials are ordered during the summer by the instructor.

### Scaffolding versus DIY University

Project scaffolding is an exercise some engineering schools use to lecture students, force them to purchase text books, and meet expertise expectations. No development of rapid-self learning, skimming, need to know, just in time, or design build take its are possible. Scaffolding kills inspiration, discourages documentation and sets the example of starting from the beginning. Students don't have to find a starting point and then retrace engineering backwards as well as engineering forwards.



Scarfolding denies prior work documentation exists that has to be leveraged. Some colleges deliberately delete all documentation after each semester's work. This creates an unethical, underground documentation system. It forces competitive complexity increases. This creates a crippling negative feedback loop. Scarfolding denies freshmen the opportunity to wrestle with the start-over, catch-up, or repeat previous success decisions that all engineers wrestle with. Scarfolding denies freshmen scope and scale experiences that moderate K-12 decisions of grandeur.

Maker Magazine, DIY University concepts and HackerSpace successes are stabilizing the open-ended project archetype. The signature of an [Uriah@JcatedSpace](mailto:Uriah@JcatedSpace) member is "teach, learn, party." If engineering colleges don't embrace open-ended projects, they will continue to grow in DIY spaces.

### Definition of Success

The big problem narrative forces an inflated definition of success that only a few can achieve. Engineering is about solving the small problems along a path of shifting scope, tools and subsystems. A suggested individual grading metric is "pushing the project forward". Celebrating these tiny successes weekly in class is absolutely necessary.

### Context

Projects don't have to be competitions. They can include: science demo, service, reuse an engineering, art, improving, prototyping, and live coding. The best project context is solving a problem defined by someone outside the introduction to engineering class ... someone called a "client". This reduces the need for the instructor to wear the client, customer, project manager and engineer hats.

### Good Clients

A freshman engineering class works best when clients are outside the classroom. Ideally these are engineers in the community. Non-engineering clients are a lot of work. College support staff can help in two ways: educate non-engineering clients and become clients themselves.

### The Course Management Problem

Managing open-ended projects in a community college is difficult. Residential engineering colleges with successful open-ended freshman projects grow and thrive where juniors and seniors mentor freshmen and sophomores. Creating this culture at a community college in isolation from the world has been impossible. Volunteers at Wikibooks and Wikiversity could change this.

### Engineering Notebooks

Engineering notebooks have not moved into the electronic world, and may never. The inspiration gained from hand writing complements that gained by white board writing and word processing.

### In the Moment versus After the Fact

Students initially turn the engineering notebook into a torture device. They try to write perfect summaries or reports. This eliminates an inspiration gained by writing in the moment. The uncertainty fog, the minute detail, the tiny but significant decision rationalization disappears unless captured in the moment. A summary is a litany of lost opportunities and lost information. Writing in the moment creates more volume, better design, better problem solving, less play, .. better engineering. The *reasons* for writing in an engineering notebook have not changed. Writing in a notebook creates an extension of the brain.

### LMS

A Learning Management System (LMS) is a useful tool. The problem is that all LMS information is controlled by the college. Colleges kick students out of the LMS for not paying their bills. Colleges delete old course information, making DIY university portfolios more difficult. Newer open source LMS systems (Canvas) do eliminate the

college's storage volume and backup issues. But ultimately the student loses. Colleges will never give up their ownership, censorship, and reuse control of information.

### Wikiiversity

Wikiaspace has changed the educational narrative. Content is pooled through entities and loose consensus. Wikiaspace separates information from its organization. It depends heavily on search engines. Search engines require knowing what we don't know. To learn what we don't know, wiki organizes information using a category concept. This makes it possible to simulate on-site documents a variety of learning paths. The richness of Wikipedla illustrates the focus on information. Wikibooks are merely extensions of the information with a lot of categorizing. The categorizational chaos of Wikimedla and Wikiversity is where the future of education can be seen.

### Wikia Promotes Reuse

Most education is trapped in a doctrine, copyright, fair use, create your own work narrative that is increasingly divorced from the modern world. Somebody somewhere has already done it and it can usually be found before a sentence is finished. Finding and controlling that public work emphasizes open-ended projects, reuse and Respect.

Students need to work in a place where reuse is encouraged, where everything they create is public domain. Some students want to improve the world, and they don't want to worry about patents, copyrights, trademarks and fair use interpretations. Creativity doesn't require starting from scratch.

### Creating Value in Public

Students will create electronic documents from others work and try to pass it off as their own because of LMS privacy. The minute students are asked to create something that can not be deleted, that will be around the rest of their lives, that will be searched by potential employers, that can change the world, that can establish respect, they start behaving professionally.

### Badges of Respect

Websites reward desired behavior with points and badges of respect. This is no different than the Boy Scouts, fraternal organizations or the military. The success of badges has been proven by the Gates Foundation and can be seen in its full implementation at the [Khan Academy](#). Wikiasites have similar rewards. The engineering profession needs to extend Wikia rewards. Engineering awards that add with FE, PE certification need to replace the increasingly awkward, random content test (despite how statistically significant it is).

### Wikia Space Introduction

Wikimedla includes Wikipedla, Wikibooks, and Wikiversity. The [Interwiki map](#) lists a variety of wikias, both for-profit and non-profit. Within wikias there are spaces. The most obvious is article space. Every registered user gets a user space. There is no privacy associated with any space. Anyone can edit pages in any space including help, category, and file space. Both the content and the file storage type must be public domain in order to be uploaded.

#### *The Internal Grading Problem*

Many different introductory Engineering grading systems have been tried including problem solution, all or nothing team, milestone submissions, time spent, and writing volume. All have problems fitting into any kind of engineering narrative. The "doing things first narrative" fits a portfolio context. Individual portfolios graded by instructors is promoted below. Team documents assessed by outside experts is more appropriate for program/course assessment.

### Portfolios

Individual students have been building individual portfolios in the [PLTW EDD](#) class. The [EDPPSR](#) (Engineering Design Process Portfolio Scoring Rubric) is being used to encourage Engineering schools, the [College Board](#) and [ABET](#) to increase:

- admissions into other project-based programs;
- admissions into postsecondary studies;
- career pathway recognition; and
- advanced Placement or dual credit into more rigorous academic courses.

The rubric doesn't measure teamwork, documentation, commitment, transparency, contribution, integrity, or persistence. The rubric has tried to create an information control point by establishing a web site to upload portfolios. The portfolio is forced into a one size fits all mold so that a "efficient" assessment process involving outside experts (College Board) can be created. Its development has been dominated by technology arts K-12 personnel, not STEM. It doesn't separate individual student grading (feedback on daily/weekly basis that forms the basis of gradual improvement) from program or curriculum assessment (goals are all individual, portfolio is individual). The rubric depends heavily upon subjectivity. EDPPSR hopes that there is a statistically significant, but as yet undisclosed "ideal portfolio" exists within the expert engineering portfolio evaluators. The positions of EDPPSR are that it focuses on documentation, raises assessment questions, and is general, not focusing on a particular technology.

### Team versus Individual

The words "teams and projects" lead students to think of sports teams, winning and losing. They are surprised when there is an individual grading component in a "project" class. The first step in grading an "introduction to engineering class" has been to create a mechanism to separate "We" and "I."

Introduction to engineering students want to socialize. "We" will happen with no effort by the instructor. The focus has to be on the individual. Engineering problems need to be separated from personal "life gets in the way" problems. Ignorance needs to be turned into a problem solving asset. Technical troubleshooting needs to be separated from engineering design. There are lots of "I" issues that start with individual defining and solving small engineering problems themselves. Open ended projects are merely opportunities to explore small engineering problems.

### Atoms versus Documentation

Students learn through hands on experiences. Given enough stuff, students will begin playing. If only the final product is assessed, the goal of forming students through playing, doing things first, design and problem solving is not addressed. Students can and will spend enormous amounts of time ... playing ... to get something to work. If that is all that is rewarded. The goal of the grading has to be encouraging students to stop and design; to stop and define engineering problems.

There are two ways to get students to stop. The first is to force students to write before, design after they do something of their choice. This improves handwriting, forces carrying engineering notebooks around and captures level of chaotic detail and inspiration that is missed in after the fact, summary writing. Currently this is being done through the [Goal to Do, Do it and Analyze](#) triplet. This evolved from the science triplet of Hypothesis, Procedure/Testing, Conclusion.

The challenge is to get students to Analyze. The Reflection of EDPPSR has been not in common with science learning reflection (personal life reflection) and not enough in common with testing, analysis, and conclusions. Analysis is described as answering questions such as: what we it right/wrong, why something went wrong, what/where is the error, if had more time/world have ....., a better tool/world have been ....., if could do over again, world have ....., if could automate, world improve ....., this was expected, and this was not expected.

Three points are given per completed project triplet of "Going To Do, Doing and Analysis". One point is given if there is no Analysis. Stride into gets one 3 of these triplets per hour on average. This is called project work in the notebook grading system. It leads to design.

Six points are given per completed problem triplet of "problem, possible solutions and testing" that can get 6 points. This quickly raises the issue of "What is an engineering problem." "I can not pop all the balloons in the Pogo.com game Poppit?" is not an engineering problem. "Can all the balloons in each game possibly be popped?" is. Single solutions are not rewarded. Stride into must brainstorm possible solutions. Testing is determined by context and has to exist. Working through these issues makes student engineers.

#### Time versus Accomplishment

Notebook writing gives a clear indication of time spent. Electronic documentation emphasizes accomplishment. Both are needed. Accomplishment starts off personal and passes from team mate to team mate like a hot potato, each adding something personal. To capture this process, four levels of electronic documentation are needed: weekly personal, weekly team, team summary, common contribution.

Weekly personal documentation is graded with post points (accomplishment points) that range from 0 to 100. Weekly team documentation is graded 40-80 points, but only if a short presentation is made. Team Summary documentation is motivated by withholding project points from the notebook and post points from individual grading until the Team Summary is done. PLTW promotes the true engineering rather than the "do it first" engineer. A Common Contribution fits into the service motto that forms the root of engineering ethics much more than minimum leading expectations of invention wealth. Help create Open Ended Projects with "Open Source" engineering!

#### The External Assessment Problem

Engineers have supported educational projects through advice, materials, money and review. Project documentation is all that is needed for external assessment. Once reviews have been accumulated, then some kind of metric can be created. Any other system is going to distort engineering. Engineers want to evaluate projects so they can evaluate individual student portfolios, teachers, courses, or an engineering program.

#### Assess Uniqueness

Every project, every problem an engineer encounters is unique whether in school or on the job. Why are all stars to be unique? Why does every McDonald's but require an engineer? Projects need to be unique. Let K-12 and tech programs argue the merits of hot dog launching projects.

#### Assess Repeatability

The difference between Edison and Tesla was documentation. The audience of documentation is other engineers. Engineers read documentation with one question in mind, "Could I replicate this?"

#### How

Assess by editing wikis by pages. Change pages if the assessor can clearly, don't penalize. Celebrate communication that leads to clarity, not clarity itself. Don't try to create an assessment rubric. Read and react like an engineer. Read other assessments. Let them inform the current. Wikis by success is more about process than pointing stagnant information. Wikis has lowered the barrier to document storage, document linking and document change control... for the planet.

A critical mass of non-engineers is already in wikis. Festina stride into named the team "ManBearPig." A wikiversity editor deleted the team's project page within a day. Stride into solved the problem with a new name. No track record means no respect, no job. Wikis is already about respect.

## Gain Respect Yourself

Ultimately the world of engineering projects will evolve an organization with a promotion process through levels of responsibility and influence. Start as a student. Continue as a working engineer. Help guide engineering assessment through the planet.

### *What's Next?*

Help edit the book "[General Engineering Introduction](#)" in Wikibooks. Assess [general engineering projects](#) in Wikiversity.

## Fear Content

Content may no longer be the control point. Students can find answers before the question is finished. Calculation-only tests are cruel. While a student can not find an answer to any question, a project is born. How does one prove there is no answer to the question? How does one prove the question is badly formed? These are the more important issues.

Respect now starts with creativity rather than content expertise. Projects are the starting point. Every engineering course should be evolving into an open-ended project course. Imagine projects dictating content. Instructors advise. Students choose courses based upon the projects they tackle rather than arbitrary content. Projects can exist outside the educational institution boundaries of grades, semesters, and budgets. Instructors need to turn into likable program managers. Projects need to dominate over content.

Pushing static into high schools will not solve the content/time problem. In summary, encyclopedia-like courses can not compete with open-ended projects.

## DIY, Hackerspaces

DIY and Hackerspaces are a modern cliché. Members pay dues and are always trying to dream up cool (open-ended) projects that will attract new members. One hackerspace is hacking the Bible. They will replace traditional engineering practice if nothing changes.

## Feeding Birds

A [hackerspace](#) decided to celebrate the 60th anniversary of [Richard Hamming's original paper](#). Six people sat facing each other over a narrow table with a power strip down the middle. Each had a [netbook](#). They were reading the paper online. They started off talking about how far they got in the paper, where they got stuck, what was confusing.

The older engineer tried to clear up some confusion. The hackerspace members glanced at him and then started chattering with each other across the table, typing madly at their computers. Then there was a collective silence and all of them looked at the older engineer. The older engineer talked again. The cycle repeated like if nothing one had anything to say.

The older engineer left feeling like he had just fed some birds. Some understood little, some a lot. They trusted the information they found on the net. They trusted that the collective mind in that room could figure anything out. They didn't feel obligated to understand everything. They had boundaries that the older engineer did not have. The older engineer felt obligated to absorb any information in the article or book. What sets the boundary of the younger people?

The next generation's context is evolving on the web, not in textbooks or articles. What web sites are popular? What are their names? What is a wiki page? The boundaries of younger people seem to be set personally. Brains are being structured to hold searchable keywords (artifacts or artifacts like [highrise](#) or [instructional](#)), not content. Do we really want to answer the boundary question? ..yes it is "open-ended projects".

## **Understanding Globalization for the 21st Century Engineer**

Dr. S. Jimmy Gandhi, Stevens Institute of Technology

Dr. Michael McShane, Old Dominion University

### **DR. S. JIMMY GANDHI**

He is a faculty member in The School of Systems and Enterprises at Stevens Institute of Technology in Hoboken, NJ. His research interests include risk management, globalization and engineering education. Currently he is co-authoring a book on Systemic Risk Management and another one on Case Studies in System of Systems Engineering (SoSE). Dr. Gandhi got a PhD in Engineering Management at Stevens Institute of Technology, a Masters in Engineering Management at California State University, Northridge and a Bachelors in Engineering at The Illinois Institute of Technology in Chicago. He is actively involved in several professional organizations such as The ASEM and the ASEE and is also a member of the Emerging Risk Initiative (ERI) at Old Dominion University.

### **DR. MICHAEL MCSHANE**

He is an associate professor at Old Dominion University and has been at ODU since 2007. He has worked in HP's semi conductor and test equipment research and development facility for over 10 years before he came to ODU. Dr. Mcshane's research interests include Enterprise Risk Management, and financial services regulation. He got a PhD from University of Mississippi, an MBA from Western Kentucky University and a B.S. in Electrical Engineering from University of New Mexico.

## Understanding Globalization for the 21<sup>st</sup> Century Engineer

### Abstract

Globalization has been defined as a force of economic growth, prosperity and democratic freedom. However, it has simultaneously been defined as a force for environmental devastation and exploitation of the developing world – thus opening our eyes to the co-existence of both benefits and risks associated with globalization.

In today's competitive global business environment, the supply chain has changed dramatically in the last two decades for a lot of organizations. Hence engineers of the 21<sup>st</sup> century need to be aware of the global supply chain and understand that they are designing products and services for a global market place. Due to this, they need to be fully cognizant of the concept of globalization and understand how it affects their profession.

In this paper, the authors discuss the benefits and risks associated with globalization. Effects of globalization on various business functions are elucidated, and the case is presented for the need for engineers to understand these effects. Lastly, the authors discuss the global strategies of organizations in the 21<sup>st</sup> century including increased complexity in vendor qualification and standardization.

### What is Globalization?

The word “Globalization” first surfaced in the English language in 1959 and entered a dictionary two years later [1]. Knowledge of the term globalization must include a dissection of the term and a careful, as well as critical, examination of all the aspects involved. A muddled or misguided core concept compromises our overall comprehension of the problem. In contrast, a sharp and revealing definition promotes insightful, interesting and empowering knowledge, an understanding that helps us to shape our destiny in positive directions [2], i.e, in order for the concept of globalization to maintain any analytical usefulness, it must be unpacked, carefully defined and examined for its impact on society, the economy and the world system[3].

Globalization has been varyingly used in academic literature to describe a process, a condition, a system, a force and an age [4]. Given these competing labels have very different meanings, their indiscriminate usage is often obscure and invites confusion related to the term “Globalization.” This is also prevalent because Globalization is an uneven process; meaning that people living in various parts of the world are affected very differently by this gigantic transformation of social structures and cultural zones [4].

Hence, it is necessary to think of globalization from varying perspectives and also to realize that Globalization is a complex phenomenon that comprises several aspects. Some researchers say that economic processes lie at the core of globalization. Others say the political, cultural, environmental or ideological aspects are the essence of globalization [4]. However, the most appropriate understanding of globalization would state that each of the above researchers have correctly identified one important dimension of the phenomenon of globalization. However, the collective mistake lies in the researchers' dogmatic attempts to reduce a complex phenomenon like Globalization to a single domain that corresponds to their area of expertise. Fortunately, with increasing research being done in the field of Globalization, more and more researchers have started thinking along the lines that an understanding of globalization requires a multi-dimensional approach.

Table 1 gives us a few commonly sighted definitions of Globalization

Table 1: Commonly cited definitions of Globalization

### **Author & Affiliation**

Anthony Giddens (*Former Director of London School of Economics*)

Fredric Jameson (*Professor of Literature, Duke University*)

David Held (*Professor of Political Science, London School of Economics*)

Roland Robertson (*Professor of Sociology, University of Aberdeen, Scotland*)

James Mittelman (*Professor of International Relations, American University, Washington*)

### **Definition**

Globalization can be defined as the intensification of worldwide social relations which link distant localities in such a way that local happenings are shaped by events occurring many miles away and vice versa.

The concept of globalization reflects the sense of an immense enlargement of world communication, as well as of the horizon of a world market, both of which seem far more tangible and immediate than in earlier stages of modernity. Globalization may be thought of as a process (or set of processes) which embodies a transformation in the spatial organization of social relations and transactions – assessed in terms of their extensity, intensity, velocity and impact – generating transcontinental or interregional flows and networks of activity, interaction and the exercise of power

Globalization as a concept refers both to the compression of the world and the intensification of consciousness of the world as a whole

Globalization compresses the time and space aspects of social relations

These definitions point to four qualities or characteristics at the core of the phenomenon. They are [4]:

- (i) Globalization involves the creation of new, and the multiplication of existing social networks and activities that cut across traditional political, economic, cultural and geographical boundaries.
- (ii) Globalization is reflected by the expansion and stretching of social relations, activities and interdependencies.
- (iii) Globalization involves the intensification and acceleration of social exchanges and activities
- (iv) Globalization processes do not occur merely on an objective, material level but also involve the subjective plane of human consciousness. The compression of the world into a single place increasingly makes global the frame of reference for human thought and action. Hence, globalization involves both the macro structures of community and the micro structures of personhood. It extends deep into the core of the self and its dispositions, facilitating the creation of new individual and collective identities nurtured by intensifying relations between the individual and the globe.

### Everyday understanding of globalization in the engineering domain:

For the practicing engineer, an understanding of globalization is the increasing integration and interdependence among countries resulting from the modern flow of people, trade, finance and ideas from one nation to another. The World Bank, a strong supporter of globalization, defines the term as, “The growing integration of economies and societies around the world” [5, 6]. Globalization is also thought of as the “shrinking” of the world and also to the increased consciousness of the world as a whole. It is a term used to describe the changes in societies and the world economy that are the result of dramatically increased cross border trade, investment and cultural exchange. One of the primary changes is to think of an interconnected world and global mass culture, often referred to as a “global village” [7].



From an engineering perspective, globalization is about the monumental structural changes occurring in the processes of production and distribution in the global economy. These structural changes are responses by many global enterprises that confront tremendous pressures and fantastic opportunities presented by the increased application and integration of technologies. It is through this application of technologies that companies have been able to break apart business functions that were previously thought to be best collocated, and spread them across the globe in a globally disarticulated labor and production process. At a secondary level, globalization is affecting all of the social, political and economic structures and processes that emerge from this global restructuring, specially the central role that knowledge, education and learning have taken up. In fact some analysts argue that knowledge, education and learning are more important for globalization to succeed than land, labor and capital. This is why we are said to be living in a knowledge economy in the 21<sup>st</sup> century [8, 9]. To sum it all up in simple terms, globalization can be thought of as the array of impacts that arise from the increasing tendency for national borders to be crossed by people, goods, services and information [10].

Lastly, in certain situations, when engineers in the U.S. think of globalization, they also think of outsourcing and the fact that a lot of jobs in the U.S., particularly in manufacturing, have been lost to other countries [11-14]. This aspect of globalization has come about because of the existence and development of an advanced network of information and communications infrastructure, based on a network of telecommunications, broadcasting, computers and content providers.

As typifies complex phenomenon, globalization also has pros and cons associated with it. The pros and cons can be evaluated and would vary depending from which perspective they are evaluated. For the purpose of this paper, we will evaluate the pros and cons from the perspective of the US economy and from the perspective of the other economies that the US has increasingly started trading with since globalization took off in the late 80s and early 90s.

The advantages and disadvantages of globalization have been heavily scrutinized and debated in recent years. Proponents of globalization say that it helps developing nations “catch up” to industrialized countries much faster through increased employment and technological advances. Critics of globalization say that it weakens national sovereignty and allows rich nations to ship domestic jobs overseas where labor is much cheaper and as a result only increasing profits for multinational companies. The benefits and risks associated with globalization are discussed in the following sections of this paper.

### Benefits of Globalization

We evaluate the benefits of globalization from two perspectives: (i) From the perspective of the US economy and (ii) From the perspective of the economies that the US has increasingly traded with since globalization has become more prominent in the last two decades.

- (i) *Benefits of globalization from the perspective of the U.S:*
  - a. The U.S. has greater options to choose from when it comes to trading partners, which leads to greater competition, which in turn leads to lower prices and higher efficiency [15, 16].
  - b. U.S. companies are able to take advantage of cheaper labor in developing countries, leading to increased profits as well as lower costs of the end

deliverables to the user, which is the U.S consumer [7, 17, 18]. However, in the last 1-2 years, analysts speculate that some manufacturing jobs might return to the U.S. due to rising labor costs in China [19, 20].

- c. Due to globalization, many U. S. firms have been able to focus on their core competencies as a way to gain a competitive advantage and add unique value to their stakeholders. It helps the organization not to squander valuable time worrying about support operations. Instead, organizations can devote their top talent to nurturing, building and leveraging core competencies which provide them more of a competitive edge as compared to concentrating on support activities [21] and thus help create more jobs that promote innovation, which is a primary factor that drives the U.S. economy.
  - d. By 2015 there will be a significant reduction in the U.S. workforce. Seventy million baby boomers are expected to be leaving the workforce and only 40 million workers entering to replace them. Thus, there could possibly be a large pool of unfilled jobs especially in the fields of science and technology. One of the possible benefits of globalization for U.S. companies is to give these organizations an opportunity to access talent from across the globe and prevent a labor crisis in the U.S. [22].
  - e. Because technology evolves so rapidly, by the time a firm invests in, trains its staff and implements a certain technology, it may already be obsolete. Under these circumstances, it does not make economic sense to maintain a permanent technical workforce. Instead, the organization can look for state-of-the-art technology from a wide variety of vendors, which is only possible due to globalization. Thus, U.S. organizations can continue to have access to state-of-the-art technology, as well as the professionals who are trained to use or implement the technology, for a much lower fixed cost [23].
- (ii) *Benefits from the perspective of the economies that the US has increased trade with:*
- a. Due to globalization, many jobs have been created in various developing countries or in “provider destinations” as they are called in globalization language. This has led to higher incomes for the populations of those countries, thus benefiting them with a better living standard due to increased disposable incomes.
  - b. Globalization has led to increased technology transfer to other countries from the developed world, leading to higher living standards resulting from advances in technology in the fields of health care and infrastructure.
  - c. Globalization has led to a significant increase in foreign direct investment (FDI) in the developing countries which has helped those governments provide better infrastructure.

### Risks of Globalization

According to Taylor [24], the term “risk” refers to potential problems or issues that may arise and adversely impact the progress or outcome of a project. Risk is a part of every project and is usually associated with adverse or negative outcomes and is therefore perceived as a danger or hazard [25]. In a challenging global economy, it is progressively more difficult to put together a project which is both effective and cost efficient. This difficulty arises in part because a project’s complexity continues to increase exponentially and the number of stakeholders involved in globally dispersed projects is expanding rapidly [26].

Consistent with the earlier section on the benefits of globalization, the risks of globalization are evaluated from the following two perspectives.

- (i) *Risks perceived due to globalization from the perspective of the U.S.:*
  - a. One of the primary risks that the U.S constantly deals with as an outcome of globalization is dealing with global instabilities stemming from the interdependencies of economies on a worldwide basis.
  - b. Currency fluctuations also take place on a day to day basis due to increased foreign currency trading between various nations
  - c. High rate of unemployment in the U.S. because of a large number of jobs, particularly in the manufacturing sector, being shipped overseas. This high unemployment rate also puts political pressure on the government in Washington.
  - d. Increasing prices of oil due to heightening demand in developing countries which is an outcome of globalization, and directly the U.S as we are an oil dependent economy.
  - e. When selecting vendors or providers to work with overseas, U.S. organizations face the threat of choosing an inappropriate vendor who would not be able to meet project requirements. The organization could also face the threat of the vendor appropriating their ideas to produce a competing product or service [23, 27, 28]
  
- (ii) *Risks perceived by the countries who the U.S. has increased trade with due to globalization:*
  - a. Slavery and child labor is a major issue that developing countries are dealing with as an outcome of globalization. U.S. companies such as Nike have been caught operating sweatshops to employ cheap labor and do not adhere to any sort of standards for their employees overseas due to lack of implementation of rules by the overseas governments.
  - b. Despite the fact that globalization has resulted in increased incomes in developing countries, there is still a huge disparity in the distribution of income across the globe. The global income is approximately \$31 Trillion a year, but 1.2 billion people still earn less than \$1/day. This results in 80% of the global population earning only 20% of the global income [29, 30] and this 80% of the global population primarily lives in the developing countries.
  - c. Due to expansion of U.S. fast food franchises overseas, the developing countries also have to deal with “McDonalozation of Societies,” which refers to the obesity rates increasing in those countries due to consumption of fast foods, that are high in fat content, but are becoming increasingly popular in those countries due to

strong branding and powerful marketing. This has led to increased health care costs in those countries due to health complications related to obesity.

- d. The environments in the developing countries are being exploited for the financial gains of large corporations and this leads to various complications to the regional and in some cases even the global ecosystem.
- e. Due to the time difference between the U.S and the “provider countries” and the “24/7 work culture” that has arisen as a result of globalization, the populations of these provider countries are experiencing increased health problems due to irregular working hours and are also noticing a spike in societal issues, which are hard to evaluate in dollar terms by the governments of the countries involved.

#### Importance of engineers understanding Globalization and the pros and cons associated with it:

Globalization is perhaps the central concept of our age. It is a highly complex interaction of forces producing integration and disintegration, cooperation and conflict, order and disorder. Accordingly, the complexities associated with globalization have increased exponentially as compared to a few decades ago. Hence, since in today’s economy, engineers design products for a global marketplace, they need to understand the following aspects of globalization:

- (i) They need to understand the risks associated with their product or service offerings and also the interconnections between those risks, i.e, they need to understand risks from a systemic perspective [31].
- (ii) Engineers, particularly those who work for Transnational Corporations (TNCs), have to deal with inefficient performance of the departments located in different parts of the world and communication problems that arise as a result of that. A clear understanding of globalization would enable engineers to do a better job dealing with this issue.
- (iii) Engineers need to understand the economics that are associated with their product or service. These economics could vary significantly, from time to time, for projects that are performed from different parts of the world. An understanding of globalization would enable engineers to better comprehend and resolve this complication associated with projects they work on.
- (iv) In the U.S., the majority of the engineers, work on design problems and the production is outsourced to various vendors in countries where the labor is significantly cheaper. Accordingly, engineers need to understand the various types of contracts such as unit pricing, fixed pricing, variable pricing and performance based pricing [32].
- (v) When U.S. engineers collaborate with other engineers in different parts of the world, they need to understand different cultures and how to deal with them so as to have a fruitful interaction with their peers in different countries [33].

#### Areas affected by globalization which engineers should be aware of [34]:

- World Trade & Investment – Engineers should be aware that world trade has experienced a 27 fold increase in the last 6 decades. This should make them aware that they are part of a global economy and hence should be aware of varying

- globalization issues if they are to remain competitive. However, despite the extent of poverty having decreased, at the same time, 80% of the world's population lives on 20% of the world's income. Hence, engineers should realize that they have to design products that are extremely cost efficient and also sustainable over the long run. Foreign Direct Investment (FDI), which has increased drastically as a result of globalization, can alter methods of production and thereby initiate much more change than the simple trading of goods, which engineers need to be aware of.
- Technology – Engineers are aware that the IT revolution the world went through is reshaping economies and societies around the globe. It provides them with new ideas and increased access to information, which improves overall efficiency while producing products or providing a service. It also leads to significant drops in cost of technology making it more accessible to people and thus leading to increased connectivity and a knowledge based society. This makes the consumer more savvy, with a larger choice of products to choose from -- thus putting more pressure on the engineer to design products more efficiently.
  - Intellectual Property – Engineers need to understand the varying intellectual property (IP) laws and their implementation that exists and vary from country to country. In today's globally connected economy, intellectual property is stolen on a regular basis and it costs the U.S \$500 billion in lost revenue every year due to counterfeit goods. Due to this, engineers must understand the risks associated with IP being leaked to or being stolen by overseas colleagues and also the value of their IP must be understood.
  - Energy – Due to globalization and outsourcing, there is a huge demand for energy in the developing countries, particularly in the BRIC nations, which comprise of Brazil, Russia, India and China. Due to this increasing demand, oil prices are at an all-time high and the pinch is being felt across various domains regarding the shortage of resources. Due to this engineers need to understand concepts such as sustainability – both environmental and social, when designing new products, which was practically non-existent before the concept of globalization, came into play. Engineers also need to be aware of issues such as the carbon footprint and water footprint of the entire supply chain associated with the product.

### Global Strategies of Organizations

The reaction of organizations to changes in international competition is an important but under-explored aspect of adjustment to globalization [35]. The primary phases followed by U.S. organizations, in implementing global strategies, are as follows:

- Strategy Formulation
- Feasibility
- Preparation (Selecting Vendors)
- Evaluation of the foreign market
- Commitment/Investment
- Transition

- On-going management

One of the particularly tedious and tricky tasks that TNCs have to deal with is increased complexity in vendor selection. Since TNCs are global players, they have a huge pool from which they can select vendors. However, they need to understand intricate details associated with vendor qualification such as: Relationship Management, Vendor Capability, Breadth of services offered by the vendor as well as the experience and reputation of the vendor. According to a study done by IBM [17], the best practices which U.S organizations affected by globalization (TNCs) tend to implement are:

- (i) The organizations become business partners with their vendors and are not mere buyers.
- (ii) The organizations realize that it is not all about price but about obtaining the best value from having global relationships with partners across the world.
- (iii) Organizations integrate their suppliers into their own supply chain to the extent of involving them in decision making and change initiatives in order to make the business relationship more of a partnership in which the risks are shared and both parties could be held accountable.
- (iv) Organizations train employees to understand the differences in culture and thus enable their employees to more easily integrate into the global marketplace and product better value for their organization.

Engineers need to understand these aspects of global strategies that organizations implement, so they can be aware of the bigger picture and contribute more effectively to the organization's overall goal.

Future outcomes due to continuing globalization which engineers need to be aware of:

Over the past two decades globalization has completely transformed how nations are conducting business in the world. The increases in technology and liberalization of government policies have led to an increase in inequality among nations as well as between social classes in a single country [5]. Some of the future trends in globalization which engineers should be aware of are:

- (i) Because of all the factors associated with globalization discussed in this paper, there will continue to be an increase in complexity, diversity and the number of stakeholders involved. Some of the stakeholders and their roles are listed below in Table 2 showing how different stakeholders have varying interests causing the complexity of projects involving globalization to be significantly greater than for domestic projects. It is also necessary for the engineers as well as managers to understand the stakeholders and how they interact.

Table 2: List of various stakeholders and their roles in globalization projects

Stakeholder	Primary Role
Client	Buying services of end product
Provider	Selling services or products
Advisory Firms	Providing quality advice to clients and providers
Government in provider country	Increase business and FDI
Government of client company country	Protectionism
Non-profit organizations	Serve as a watchdog
Professional Organization	Educate through events, certifications and standards
Academia	Research in the field of globalization

- (ii) There will continue to be multiple providers for a single project as globalization continues to mature and organizations continue to look for the best value. As a result, engineers need to understand integration issues to much greater extent than when they dealt with a single provider.
- (iii) Virtual teams will continue to operate and increase in numbers resulting in a greater number of engineers working remotely with other team members. Due to this engineers have to learn to be better communicators and also be aware of cultural issues that may arise while communicating with colleagues in different parts of the world.
- (iv) Customers will take a greater role in driving and designing products requiring engineers to listen to the voice of the customer even more closely than they currently do.
- (v) Rising prices of oil will force companies in high wage countries to continue to be involved in globally disbursed projects and thus in globalization. This will put more pressure on engineers to device ways to “design more using less”.
- (vi) Vendor focus will shift from basic skills and low costs to domain knowledge, transition challenges, change management and HR issues.
- (vii) There will be an increase and shift in venture capital funding from West to East.

### Conclusion

This paper provides an overview of the benefits and risks of globalization that engineers will need to understand in an increasingly dynamic and interconnected world. The era of globalization is pushing demand for a new type of engineer. In a previous age, an engineer worked with a black box mindset and might only need to understand the particular subsystem he was working on and not the entire system. Engineers evolved with the need to understand the entire system and think beyond just the engineering phase to consider the needs of other departments within the firm, such as designing for ease of assembly for the production department and ease of use for the marketing department. With globalization, engineers are required to think far beyond the firm walls, and require an understanding of various cultures and types of communication.

This new world will challenge engineers who like other professionals tend to dwell in silos. The silo approach is not suited to dealing with a dynamic environment characterized by complex issues such as rapid changes in information technologies, the explosion of globalization and outsourcing, and increased competition. A transdisciplinary and integrative way of thinking is required. While engineers are not yet well-equipped and experienced to deal with the globalization issues raised in this paper, they are familiar with useful tools, such as the systems approach, which can be a springboard to adapting in this new era.

### References

- [1] R. J. Schreiter, *The New Catholicity: Theology Between the Global and the Local*. Maryknoll, N.Y. : Orbis Books, 1997.
- [2] J. A. Scholte, "Defining Globalisation," *The World Economy*, pp. 1471-1502, 2008.

- [3] D. Coghurn, "Globalization, Knowledge, Education and Training in the Information Age " 2009.
- [4] M. Steger, *Globalization: A Very Short Introduction* New York: Oxford University Press, 2009.
- [5] T. Bishop, J. Reinke, and T. Adams, "Globalization: Trends and Perspectives " *Journal of International Business Research* vol. 10, pp. 117-130, 2011.
- [6] I. Mukherjee, "Impact of Globalization on International Trade " *ICFAI Journal of International Business* vol. 3, pp. 28-45, 2008.
- [7] J. Stiglitz, *Making Globalization Work* W. W. Norton & Company, 2007.
- [8] P. Maassen, "The Changing Environment: Globalization and the Knowledge Economy ", ed, 2007.
- [9] M. Albrow and E. King, *Globalization, Knowledge and Society: Readings from International Sociology* 1st edition ed.: Sage Publications Ltd, 1990.
- [10] M. Weidenbaum, "Weighing the Pros and Cons of Globalization " Woodrow Wilson International Center for Scholars 2003.
- [11] L. Levine, "Offshoring (a.k.a. Offshore Outsourcing) and Job Insecurity Among U.S. Workers," Domestic Social Policy Division, Congressional Research Service May 2 2005.
- [12] AFL-CIO. (2011, September 21, 2011). *Exporting America*. Available: [http://www.aflcio.org/issues/jobseconomy/exportingamerica/outsourcing\\_problems.cfm](http://www.aflcio.org/issues/jobseconomy/exportingamerica/outsourcing_problems.cfm)
- [13] About.com, "Blaming Offshore Outsourcing for Job Loss," ed, 2010.
- [14] ACM, "Globalization and Offshoring of Software: A Report of the ACM Job Migration Task Force," Association of Computing Machinery 2007.
- [15] FREE, "The Benefits of Globalization ", ed, 2004.
- [16] Wikipedia, "What are the benefits and costs of globalization? ," ed, 2011
- [17] IBM, "Low-cost country sourcing can benefit a company's bottom line," IBM Global Business Services Somers, NY2006.
- [18] McKinsey&Company, "Labor Markets and Offshoring ", ed, 2011.
- [19] T. Corbell, "Manufacturing Jobs Might Return to U.S. as China's Labor Costs Rise " in *The Biz Coach* ed, 2011.
- [20] A. Gomstyn, "Some Outsourced Jobs are coming back " in *ABC News Online Edition* ed, 2011.
- [21] Y. Lederer and J. Tucker, "Outsourcing: Current trends, benefits and risks " *Journal of Information Strategy*, 2003.
- [22] J. Luftman. (2008) Is there a techtalent shortage? Yes /No? . *Information Week Research & Reports*
- [23] S. J. Gandhi, "An Analytical Characterization of Outsourcing Risks " PhD School of Systems and Enterprises Stevens Institute of Technology, Hoboken, NJ, 2010.
- [24] H. Taylor, "Outsourced IT Projects from the Vendor Perspective: Different Goals, Different Risks " *Journal of Global Information Management* vol. 15, pp. 1-27, April - June 2007 2007.
- [25] J. March and Z. Shapira, "Managerial Perspectives on Risk and Risk Taking " *Management Science*, vol. 33, pp. 1404 - 1418, 1987.
- [26] J. Jackson. (2007, July 27, 2007) Offshore Outsourcing has Risks *Article Alley*. Available: [http://www.articlealley.com/article\\_193815\\_15.html](http://www.articlealley.com/article_193815_15.html)



- [27] S. Sakhivel, "Managing Risk in Offshore Systems Development," *Communications of the ACM* vol. 50, pp. 69-75, 2007.
- [28] J. Gandhi and G. Eschbacher, "Risk of Outsourcing Complex Systems -- A growing Phenomenon," in *American Society of Engineering Management (ASEM) Annual Conference* Chattanooga, TN, 2007.
- [29] Global\_Education, "Globalization," ed, 2011.
- [30] The\_World\_Bank, "Governance and Goals of the World Bank ", ed, 2011.
- [31] A. Gorod, J. Gandhi, B. Sauser, and J. Boardman, "Flexibility of System of Systems," *Global Journal of Flexible Systems Management* 2008.
- [32] C. Yang and J.-B. Huang, "A decision model for IS Outsourcing " *International Journal of Information Management* vol. 20, pp. 225-239, 2000.
- [33] W. Boston, "Globalization and the Importance of Understanding Cultures ", ed, 2011.
- [34] SUNY, "Globalization 101," The Levin Institute, The State University of New York 2011.
- [35] D. Greenaway, J. Gullstrand, and R. Kneller, "Surviving globalization," *Journal of International Economics*, vol. 74, pp. 264-277, 2008.

## **Introducing Biological Mechanisms To Computer Security Students**

Qinghai Gao

Department of Criminal Justice & Security Systems  
State University of New York at Farmingdale  
2350 Broadhollow Road, Farmingdale, NY 11735  
Email: GaoQJ@farmingdale.edu

DR. QINGHAI GAO

Dr. Qinghai Gao is an Assistant Professor in the Department of Criminal Justice & Security Systems at Farmingdale State College/SUNY. Before joining Farmingdale, he taught in China University of Petroleum from 1992 to 1998. From 1998 to 2007 he taught as Adjunct in Brooklyn College, Lehman College, NYC College of Technology, College of Staten Island, and York College. Since 2001 he held positions in industry as Software Developer, Database Administrator, Network Engineer, Researcher, Consultant, and Information Security Specialist.

Dr. Gao received a PhD in computer science from the City University of New York in 2007. So far he has published one book and >20 articles. His present research interests include Digital Forensics, Network Security, Biometrics, Biological Information System, Forensic DNA Analysis, Cryptography and Steganography.

# Introducing biological mechanisms to computer security students

## Abstract:

Biology has broad impact on computer security. Many computer security approaches to defense originate from the observation of biological phenomena. However, students majoring in computer security are often lack of knowledge in these biological mechanisms and thus have difficulties in correlating the two seemingly unrelated fields. In this paper we introduce a few biological security mechanisms, such as the cryptographic and steganographic processing of biological information expressed in DNA, RNA, and protein sequences, the defensive actions against invading pathogens conducted by biological immune system, and the improved survivability of a species through bio-diversity, to bring students to a higher level in understanding biologically inspired security mechanisms and in drawing new security paradigms from the most recent developments in biology. Not only do we ask students in computer security to carry out comparative study of biological mechanisms and computer security algorithms, but also encourage faculty to develop new curriculum that can facilitate this objective. Due to the interdisciplinary nature of the subject, it is necessary to involve faculty from both computer science and biology to train students with the knowledge that are transferrable across professional boundaries.

## 1. Introduction

Biology has broad impact on computer technology. In particular, biological phenomena have been a rich source of inspiration for computer security professionals. Famous computer scientist Seymour Cray <sup>[1]</sup> once described a biological cell as a computer system consisting of the following components: several thousand microprocessors → ribosomes (RNA); Dynamic Random Access Memory (RAM) → DNA; program code organized into ~150,000 subroutines (genes); power supply → mitochondria.

Many concepts widely used in computer security such as virus, worm, and Trojan horse are borrowed from biology. Many emerging computer security techniques are invented as a result of observing the biological world.

However, students learning computer security often have difficulty understanding these borrowed biological mechanisms, which negatively affect their critical thinking skill and creativity. The main reason for the problem is due to their lack of knowledge in biological systems. One possible solution is to comparatively study biological mechanisms and their applications in computer security. Unfortunately, existing curricula for computer security and its related programs do not provide students with the necessary training.

In this paper we introduce a few biological defense mechanisms as an effort to stimulate interests in biology among computer security students.

Due to the interdisciplinary nature of the subject, it is necessary to involve faculty from both computer security and biology to co-develop new courses to train students.

As technology advances, using computer becomes an indispensable part of life for all intellectuals. It is necessary for all college graduates to have some common knowledge about

computer security to facilitate their daily routine and to protect their online privacy. Therefore, students majoring in biology can also benefit from these new courses.

The rest of the paper is organized as the following. Section 2 introduces intracellular defense mechanisms, focusing on natural cryptographic and steganographic processing of genetic information. In Section 3, we introduce intercellular defense – defense against invading pathogens by biological immune system. Section 4 discusses species defense – security through diversity. Section 5 summarizes the paper and proposes future work.

## **2. Intracellular defense - natural cryptographic and steganographic processing of genetic information**

The Central Dogma of Biology mainly includes two biological sequence mappings. One is called *transcription* from DNA to RNA and the other is called *translation* from RNA to protein. In biology, the protein making process in most species typically contains the following three steps [2].

S1: *Transcription* from DNA to pre-RNA

S2: *Splicing* of pre-mRNA to mRNA

S3: *Translation* of mRNA to protein

Fig. 1 shows the steps. In it the **pre-RNA** is the intermediate sequence in which the introns, labeled as I1, I2, I3 and I4, will be removed and the exons, labeled as E1, E2 and E3, will be ligated to form mRNA, the final template sequence for protein synthesis.

However, biologists also find a different path of making protein in some other species, as given in Fig. 2. It mainly consists of the following three steps:

S1: *Transcription* from DNA to RNA

S2': *Translation* of RNA to pre-Protein

S3': *Splicing* of pre-Protein to protein

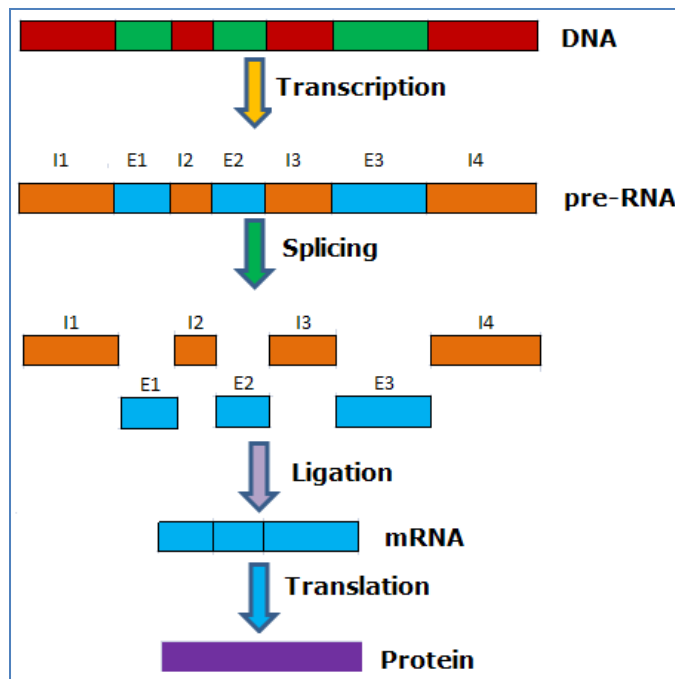


Fig. 1 Biological information flow with **pre-RNA** as the intermediate sequence

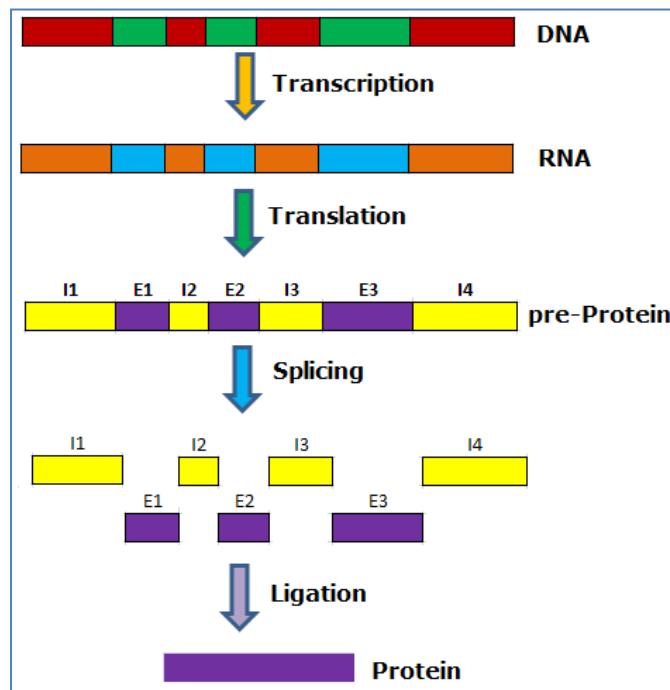


Fig. 2 Biological information flow with **pre-Protein** as the intermediate sequence

By comparing Fig. 1 and Fig. 2 we can see that the transcription steps of making protein in different species are exactly the same. The difference comes from the swapping of the translation step and the splicing step.

Viewed from the perspective of information security, the sequence mapping in the transcription step does not increase security due to the 1-to-1 correspondence between the chemical bases of

DNA and those of RNA. However, both the splicing step and the translation step transform the biological information in security-enhanced manner.

#### ●Enhance security with splicing process

In Fig. 1, the pre-RNA sequence contains introns (I1, I2, I3, and I4) and exons (E1, E2, and E3). However, for a given pre-RNA sequence the number of introns, the number of exons, and the boundaries between introns and exons are non-deterministic. That is to say, the same pre-RNA sequence can be spliced into different mRNA sequences under different circumstances. Thus different proteins can be produced.

Similarly in Fig. 2, the pre-Protein sequence contains inteins (I1, I2, I3, and I4) and exteins (E1, E2, and E3). However, for a given pre-Protein sequence the number of inteins, the number of exteins, and the boundaries between inteins and exteins are non-deterministic. One pre-Protein sequence can be spliced into different final protein sequence.

In information security, given a sequence containing dummy letters (stegotext), it is a steganographic problem on how to find and remove them to recover the original plaintext.

#### ●Enhance security with translation process

In computer security, the high-level language source code can be compared to the DNA sequence; the intermediate assembly language code can be considered as the RNA sequence; and the binary machine language code can be thought of as the protein sequence. For security purpose the binary/machine language code can be reversely engineered to its source code with a decompiler.

In biology, RNA is a base 4 system and protein is a base 20 system. The mapping from RNA to protein is a substitution cipher, in which every three consecutive symbols from RNA alphabet will be replaced with one symbol from the protein alphabet. With direct translation, one RNA sequence can only map to a unique protein sequence.

In the natural genetic code<sup>[2]</sup>, the 64 codons (triplets of 4 letter A, U, G, C,  $4 \times 4 \times 4 = 64$ ) codes for 20 amino acids. On average, the ratio of the number of RNA codons to the number of amino acid is about 3:1 (64:20). The number of possible RNA sequences for a given protein sequence of length  $n$  will be up-bounded by  $3^n$ . Therefore, it is difficult to reversely translate a protein sequence back into its corresponding RNA sequence.

### 3. Intercellular defense – defense against invading pathogens by biological immune system

According to Dasgupta<sup>[3]</sup>, “*The biological immune system is a complex adaptive system that has evolved in vertebrates to protect them from invading pathogens. To accomplish its tasks, the immune system has evolved sophisticated pattern recognition and response mechanisms following various differential pathways, i.e. depending on the type of enemy, the way it enters the body and the damage it causes, the immune system uses various response mechanisms either to destroy the invader or to neutralize its effects.*”

Biological immune system has three defensive mechanisms to eliminate invading pathogens: Clonal Selection, Negative Selection, and Immune Network <sup>[3]</sup>.

### ●Clonal Selection

In general, an organism has no predetermined way to know what kind of pathogen would invade its body so that it can produce antigens to defend against the invasion. Therefore, one cell of an immune system in an organism will produce a number of daughter cells. However, unlike most somatic cells these daughter cells are not the exact copy of the mother cell. Instead, they are the randomly mutated version of the mother cell. Upon the invading of pathogen, only these daughter cells that are effective at eliminating the pathogen will multiply at a high rate. The other daughter cells that do not contribute the elimination process will die out.

The clonal selection mechanism has many applications in computer security, such as antivirus software design and network intrusion detection. In particular it provides an effective way to detect and remove new species of computer virus and network threats.

### ●Negative selection

As mentioned in the previous section, an organism produces random cells to defend against pathogens. However, these randomly generated cells could be harmful to the survival of its own functional cells. Fortunately, the immune system has evolved a mechanism to distinguish between pathogens and self cells – negative selection. Fig. 3 illustrates the processes of negative selection.

Similar to clonal selection, negative selection mechanism has been applied in computer virus detection and network intrusion detection.

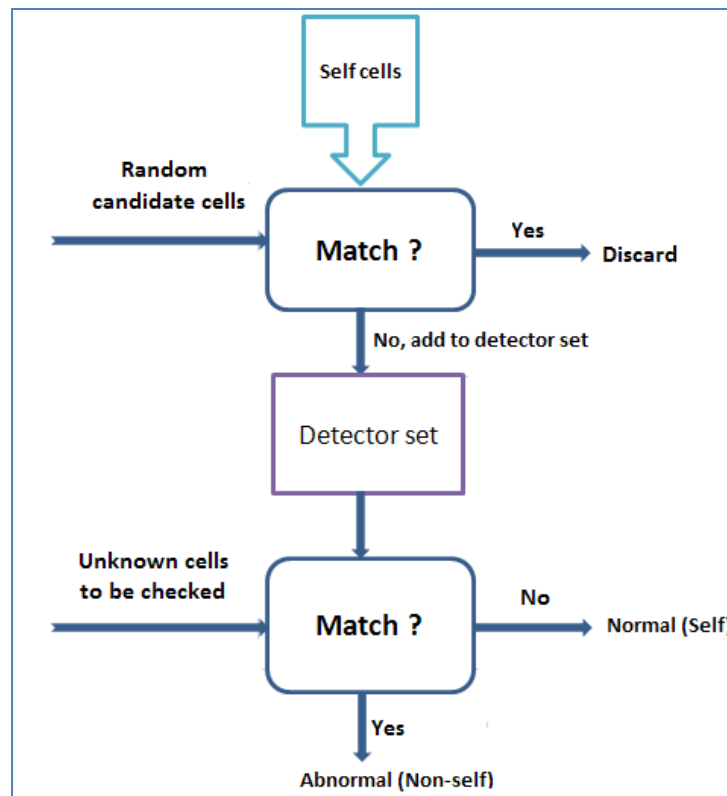


Fig. 3 Negative selection mechanism (Adopted from [3])

### ●Immune network

It is believed that the immune cells maintain an interconnected network for pathogen recognition and response. And the idea has been adopted in computer security for designing distributed antivirus and intrusion detection network.

### 4. Species defense - Improved survivability through bio-diversity

In nature, it has been observed that the outbreak of one strain of deadly and fast-spreading viruses or bacteria can decimate or wipe out an entire species. And very often the culprit virus or bacteria only harm a specific species and have no significant effects on other non-closely related species.

In computer security malwares remain the major threats to many systems. However, it is found that one computer virus or worm can only be harmful to one specific type of operating system, such as Windows. The same virus or worm could not effectively cause damage to a Linux or Mac machine because they have different “genetic codes”.

Two decades ago, Forrest et al. <sup>[4]</sup> proposed idea of improving security through introducing diversity for computer operating systems. Although the idea has been applied in certain software design, security through diversity is still an active and promising research topic.

### 5. Summary and future work



In this paper we proposed the idea of introducing biological phenomena to students learning computer security. We looked at a few biological defense mechanisms, including intracellular defense, intercellular defense, and species defense, and briefly surveyed how these mechanisms have been applied in some way in the field of computer security.

Recently, there are many security-related new developments in biology that have yet to be explored by computer security professionals. It is beneficial for students majoring in computer security to understand these developments so that they may bring new ideas and security paradigms to the field of computer security. Not only do we ask students in computer security to carry out comparative study of biological mechanisms and computer security algorithms, but also welcome faculty to develop new curriculum that can facilitate this objective. Due to the interdisciplinary nature of the subject, it is necessary to involve faculty from computer security and faculty from biology to break the traditional professional boundaries.

## Reference

- [1] Cray, S. (1996). "An imaginary tour of a biological computer (why computer professionals and molecular biologists should start collaborating)", Remarks of Seymour Cray to the Shannon Center for Advanced Studies, University of Virginia. Retrieved on September 23, 2011 from <http://www.cccp2000.com/cray.html>
- [2] Alberts, B., Johnson, A., Lewis, J., Raff, M., Roberts, K., & Walter, P. (2007). *Molecular Biology of the Cell* (5th edition), Garland Science.
- [3] Dasgupta, D. (2006). Advances in artificial immune systems. *IEEE Computational Intelligence Magazine*, 1(4): 40-49.
- [4] Forrest, S., Somayaji, A., & Ackley, D. (1997). Building Diverse Computer Systems. *Workshop on Hot Topics in Operating Systems*, pp. 67-72.

## **Deformation of Layered Polymeric Lenses and Glass Lenses under Thermal Loading**

Alison N. Garbash

Mechanical Engineering Department, Ohio Northern University

Jed E. Marquart

Mechanical Engineering Department, Ohio Northern University

Hui Shen

Mechanical Engineering Department, Ohio Northern University

# Deformation of Layered Polymeric Lenses and Glass Lenses under Thermal Loading

## ABSTRACT

Glass has been widely used as the material for optical lenses. In recent years, with advancements in technology, polymers have become candidate materials to replace glass for optical lenses. Polymers are relatively light, cheap, and easy to manufacture. Layered polymeric optical lenses, produced using coextrusion technology, have been reported to have better optical properties than glass lenses. However, polymers have relatively high thermal expansion coefficients. In this paper, comparisons have been conducted on the deformation of layered polymeric lenses and glass lenses under thermal loading. Polymeric lenses are made by alternating layers of two polymers, poly(styrene-co- acrylonitrile) and polymethylmethacrylate. 2D and 3D finite element analysis methods were utilized to obtain responses of the lenses under thermal loading. The results show a significant difference between the two materials. Layered polymeric optical lenses have larger deformation than glass lenses, and the deformation varies with the layer thickness.

## 1. INTRODUCTION

Glass has been widely used for optical lenses. With today's advancements in material technology and the driving needs for light-weight and small-sized optical lenses, gradient refractive index (GRIN) materials become candidate materials to replace glass for optical lenses. The GRIN lenses are bio-inspired by the eyes of many species such as human beings. The GRIN crystalline lenses in biological eyes typically contain approximately 22,000 layers [1]. To mimic the structures of eyes in nature, lenses made of nanolayered polymer film with GRIN distributions have been developed in recent years [1,2]. The nanolayered polymer films are made by coextrusion technology combining thousand of alternating layers of different polymers. The optical properties of GRIN lenses, such as image quality and ability to collect light, can be improved [1]. The refractive index can be changed by varying the thickness of the transparent layers [1]. Layers can have a thickness of several microns to nanometers. However, polymers have relatively high thermal expansion coefficients. The shape could change under thermal loading. This would make the optical properties more difficult to keep consistent under heat flux or temperature change. Although glass itself is heavy, it has a low thermal expansion coefficient, which allows the glass to keep its optical properties consistent through varying thermal conditions.

In this paper, responses of glass and alternating layered polymeric optical lenses to various thermal loadings were compared. Thermal loadings include a constant heat flux and a constant change in temperature with boundary condition of constant rate of convection. Simulations of different lenses were completed using ANSYS Workbench 13.0 [3]. The results show a significant difference between the two types of optical lenses. Layered polymeric optical lenses have larger deformation than glass lenses, and the deformation varies with the layer thickness.

## 2. FINITE ELEMENT MODELING

To compare the deformation of glass and polymeric optical lenses under various thermal loading, 2D and 3D finite element (FE) models were created. In this section, the 2D and 3D FE models, the material properties, boundary conditions, and thermal loadings will be described.

### 2.1 2D and 3D FE models for glass and polymeric lenses

The glass lens was modeled as a half-sphere with a radius of 1 mm as shown in Figure 1. While the objective of this work is to compare the deformation of glass lens and polymeric lens, the size of the lens is constant for all the FE models for both glass and polymeric lenses.

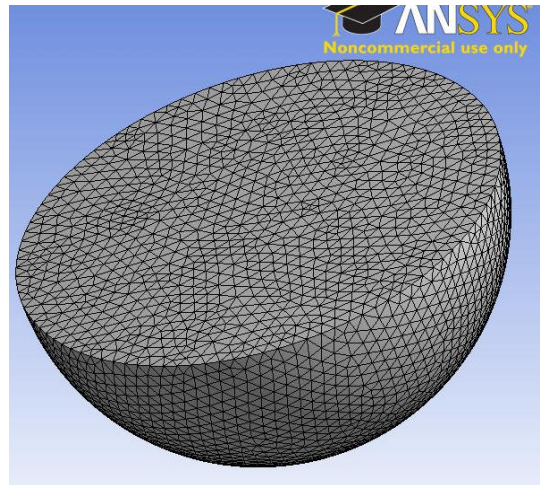


Figure 1: FE model for glass lens

The polymeric optical lens was modeled with 2, 4, 10 and 20 layers with 3D models. The 20 layer lens model is shown in Figure 2, with  $50\mu\text{m}$  thick layers. The layers were alternated with poly(styrene-co- acrylonitrile) (SAN) and polymethylmethacrylate (PMMA).

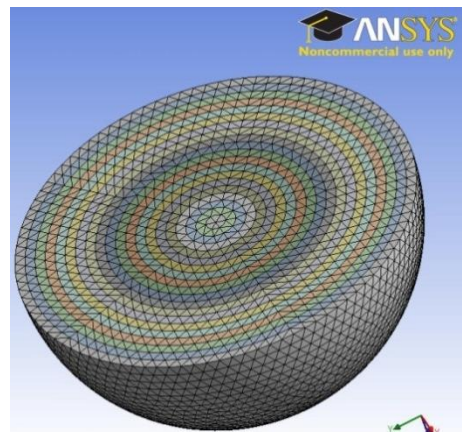


Figure 2: 3D alternating layered polymeric lens with 20 layers

Due to the axis symmetrical geometry of the lenses, the 3D lens model was converted to a 2D lens. The 20 layer 2D model is an axis symmetric FE model as shown in Figure 3. The 2D simulations allow for more layers, which would be difficult and time consuming to complete with the 3D model. The polymeric optical lens was modeled with 20 to 100 layers for 2D models. For the 100-layer model, the layer thickness is 10  $\mu m$ .

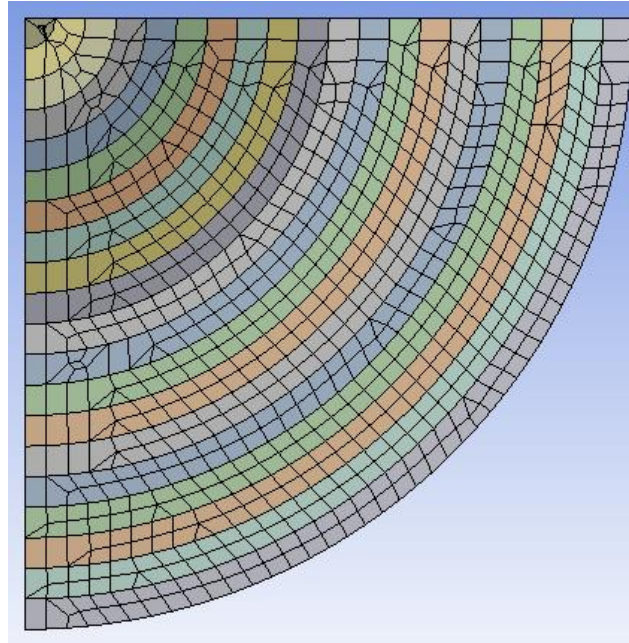


Figure 3: 2D alternating layered polymeric lens with 20 layers

All FE analyses were carried out using the ANSYS software using 2D or 3D skewness element for meshing[3]. Mesh convergence was verified based on local deformation values.

## 2.2 Material properties

Various polymers can be used to develop the lens. Which polymers are used in the lens determines the properties of the lens, including but not limited to the refractive index. Polymeric lenses are usually created by alternating layers of two or more polymers. Two polymers commonly used are SAN and PMMA [2]. With the layers set, the lens is molded into a plano-convex gradient refractive index optics lens [1]. Material properties for SAN [4- 6], PMMA [7- 9], and BK7 Glass [10] are shown in Table 1.

Table 1: Material Properties (Reference temperature: 20°C)

Material	Density $10^3(\frac{kg}{m^3})$	Young's Modulus ( <i>GPa</i> )	Poisson Ratio	Thermal Conductivity ( $\frac{W}{mK}$ )	Thermal Expansion Coefficient $10^{-6}(\frac{1}{^\circ C})$
SAN	1.05	2.5	.3	.17	90
PMMA	1.2	3.1	.4	.25	60
BK7 Glass	2.51	82.0	.206	1.114	8.3

## 2.3 Boundary Conditions

It was simulated that the lens was in a holder made of aluminum. It was held in place to allow polishing on the surface. Fixed support was chosen for the outer surface of the lens. In the polishing process, water was placed on the lens during polishing. To simulate the water sitting on the surface of the lens, the rate of convection was considered to be free convection heat transfer. The free convection rate for water is  $20 \frac{W}{m^2 K}$  [11]. A transfer rate for convection was placed on all the models and was considered to be coming off the top face and outer surface of the lens.

## 2.4 Thermal loadings

Thermal loading added to the lens model was either a heat flux or constant temperature change through the lens. The heat flux was to simulate the thermal loading during polishing of the lens. The heat flux for the lens was calculated using the conservation of energy equation:

$$\dot{E} = \dot{Q} + \dot{W} \quad (1)$$

where  $\dot{E}$  is the rate of energy transfer,  $\dot{Q}$  is the rate of heat transfer, and  $\dot{W}$  is the rate of work done.

Before using the conservation of energy, the power of the polisher needed to be determined. Using the equations below, the power of the polisher could be determined:

$$P = 2\pi\tau\omega \quad (2)$$

$$\tau = Fr \quad (3)$$

$$F = \mu N \quad (4)$$

where  $P$  is power,  $\tau$  is the torque,  $\omega$  is the revolutions per minute,  $F$  is the frictional force,  $r$  is the radius of the polisher,  $\mu$  is the coefficient of friction, and  $N$  is the normal force of the polisher.

The coefficient of friction,  $\mu$ , was found to be .35 for SAN on steel with liquid [12]. During the polishing process,  $N$  is the weight of the polisher which can be calculated from the mass of the polisher, 100grams. The  $r$  of the polisher is 5mm and the  $\omega$  is 120 *rpm*. The power of the polisher was equal to the rate of energy. Using the conservation of energy, since no work was being done the rate of energy is equal to the rate of heat transfer. The heat flux was then calculated:

$$\dot{q} = \frac{\dot{Q}}{A} \quad (5)$$

where  $\dot{q}$  is the heat flux and  $A$  is the area of the polisher. The total heat flux was determined to be  $216.5 \frac{W}{m^2}$ .

Another thermal loading was constant temperature change through the lens. The change in temperature value selected was 20°C. The change in temperature was constant through the entire lens. This thermal loading was to simulate the environmental temperature change. All lenses had an initial environmental temperature of 22°C.

## 3.RESULTS

In this section, the deformation for the models of glass lens and polymeric lens responding to different thermal loadings are compared.

### 3.1 Results for the Glass Lens Model

Figure 4 and Figure 5 show the total deformation of the glass lens under the heat flux and temperature change. It can be observed that the center of lens has the largest deformation, which is shown in Table 2. The maximum deformation value for each model will be used to compare with those of polymeric lens models in the following section.

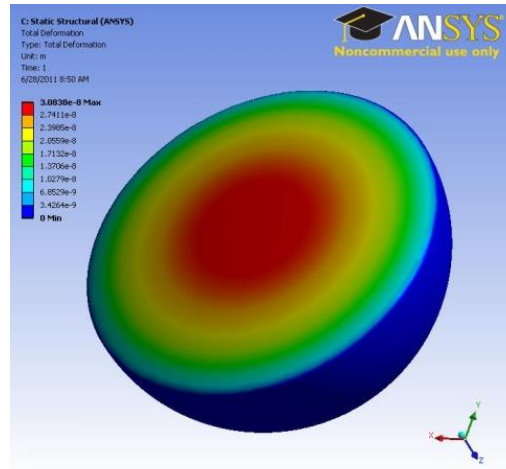


Figure 4: Total deformation of the glass lens with heat flux.

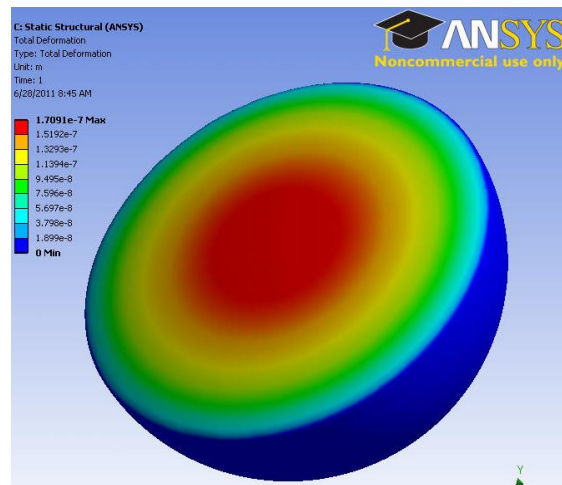
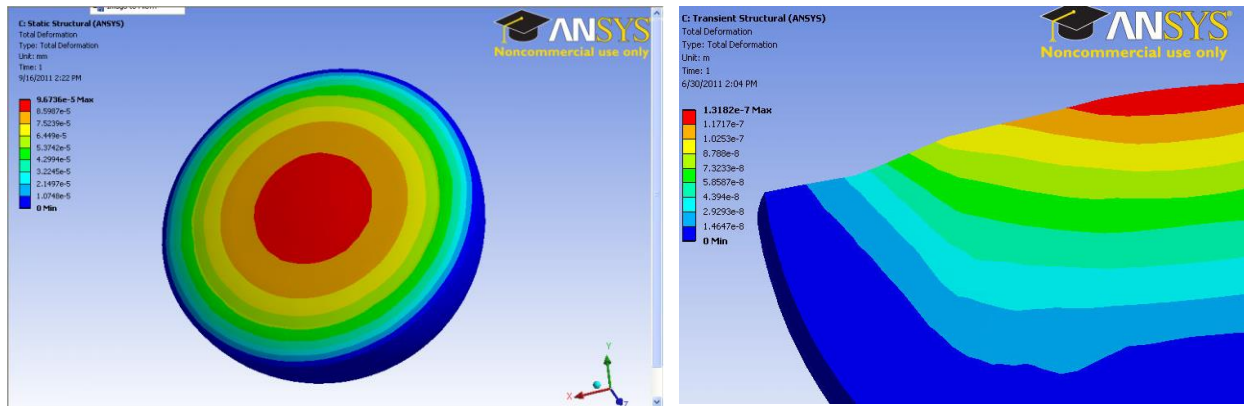


Figure 5: Total deformation of the glass lens with temperature change.

### 3.2 Results for the Polymeric Lens Model

The polymeric optical lens was modeled with 3D models for 4, 6, 10 and 20 layers, and 2D models for 20, 40, 60, 80, and 100 layers. The 3D 20 layer model and 2D 20 layer models were compared to verify that the two types of the models obtained similar results. The deformation of 4, 10, 20, and 100 layer polymeric lens models under heat flux with the fixed surface boundary condition are shown in Figures 6-9. It can be observed that for the layered polymeric lens the surface forms grooves when deformed. This is due to the different thermal expansion coefficients of the two polymers. Under the same thermal loading, the two different polymers expand differently. As the number of layers increase, the deformation becomes more evident. However, the grooves become shallower and the

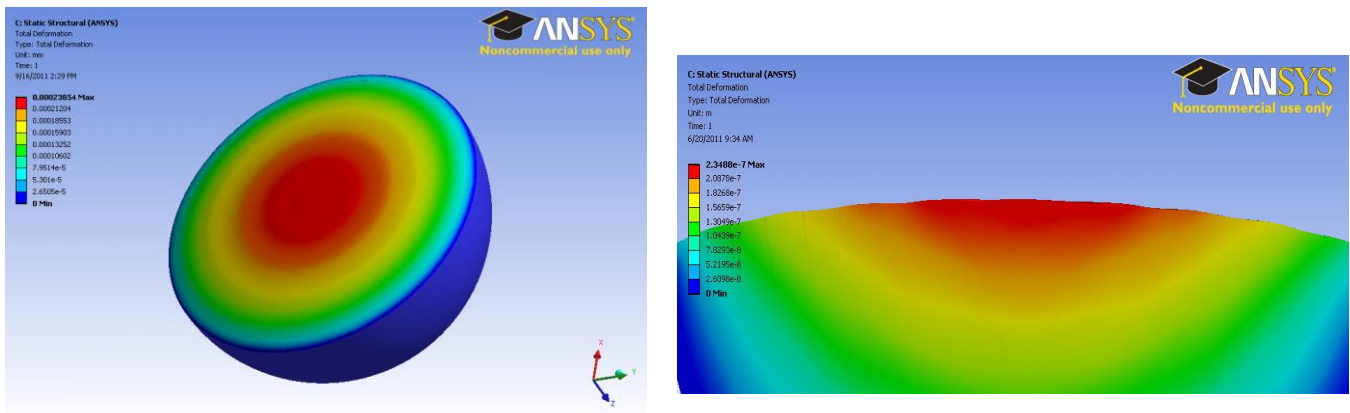
surface becomes smoother. The model was sectioned in order to see the different deformations that occurred between the alternating polymer layers.



(a)

(b)

Figure 6: 4 layer polymeric lens with heat flux. (a) overall deformation; (b) section view to show the local deformation.

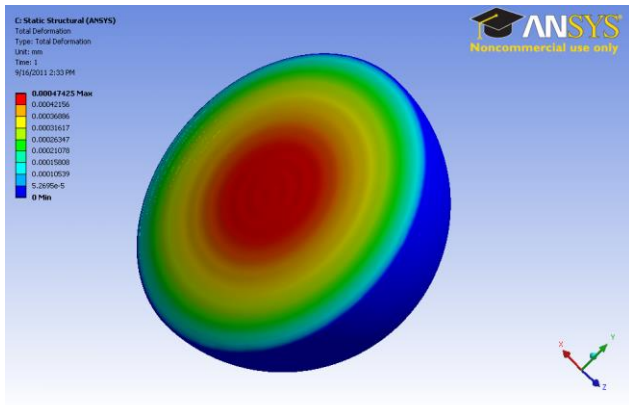


(a)

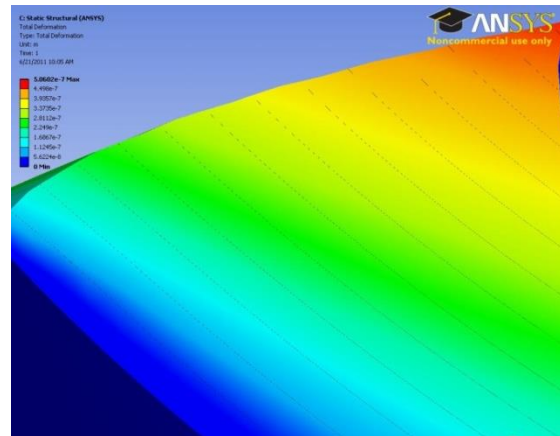
(b)

Figure 7: 10 layer polymeric lens with heat flux. (a) overall deformation; (b) section view to show the local deformation.





(a)



(b)

Figure 8: 20 layer polymeric lens with heat flux. (a) overall deformation; (b) section view to show the local deformation.

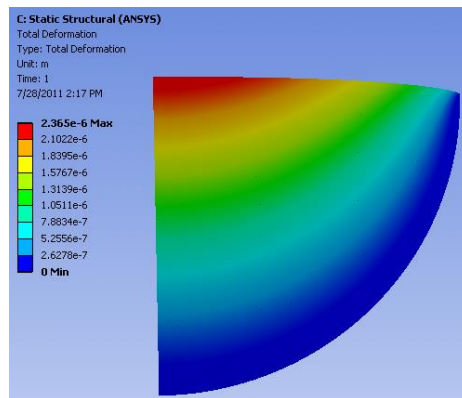
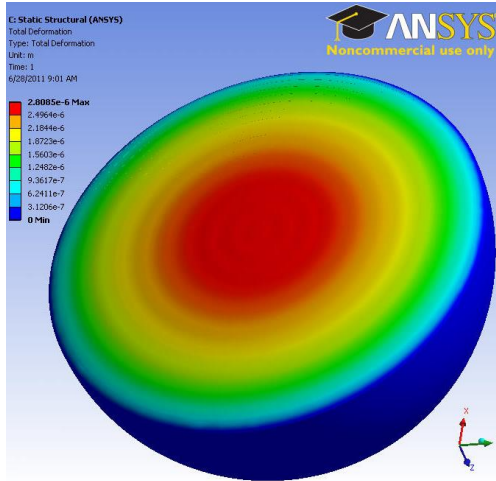
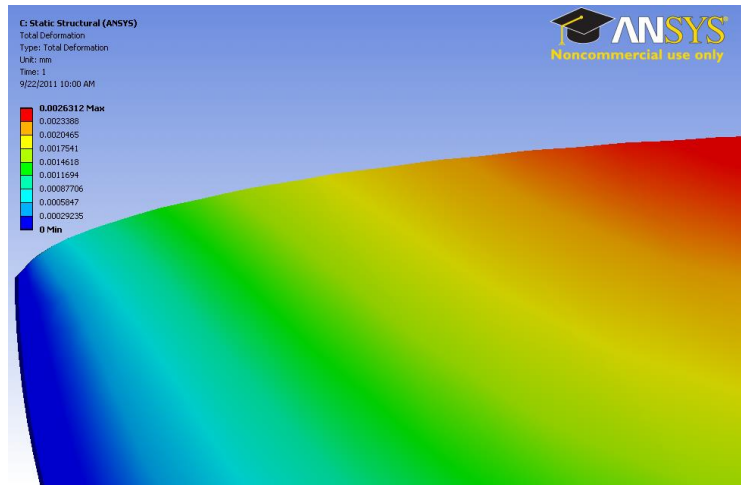


Figure 9: Overall deformation for 100 layer polymeric lens with heat flux (2D model).

The deformation of the 20 layer polymeric lens model under temperature change is shown in Figure 10. It can be observed that the temperature change still caused the wavelike deformation between the polymer layers to form.



(a)



(b)

Figure 10: 20 layer polymeric lens with temperature change. (a) overall deformation; (b) section view to show the local deformation.

### 3.3 Comparison between glass lens and polymeric lens

The maximum deformation values of the glass lens model and polymeric lens models with various number of layers are listed in Table 2. It can be concluded that as the number of layers increase the deformation increases. As the layer number increases from 4 to 100, the deformation increases about 24.5 times under heat flux and temperature change. The relationship between the number of layers and deformation under thermal loading is approximately linear. The glass lens has lower deformation, which is about 1.3% of that of the 100 layer polymeric lens.

Table 2: Maximum deformation for glass and polymeric lens models

Number of Layers (Polymeric)	Deformation under heat flux $10^{-5}$ (mm)	Deformation under temp change $10^{-5}$ (mm)
4	9.67	53.7
6	14.4	79.9
10	23.9	132
20	47.4	263
40	94.6	525
60	142	787
80	189	1049
100	237	1311
<b>Glass</b>	<b>3.08</b>	<b>17.1</b>

#### 4. Conclusions

The objective of this project is to compare glass and alternating polymeric optical lenses' responses to various thermal loadings. Two thermal loadings were applied on glass and alternating layer polymeric lenses to simulate the heat produced by polishing the surface and environmental temperature change. When comparing the deformations of the lenses, the polymeric lens had greater deformations than the glass lens. The maximum deformation of glass is only 1.3% of that of 100 layer polymeric lens. The relatively large deformation of the polymeric lens might have an effect on the optical properties. The two different lenses, glass and polymer, each have their pros and cons to being used. If thermal loading is not a major concern, the alternating lens would make a good choice. The glass lens would be a better choice if heat load is a concern. The material chosen to use would depend on what the lens would be needed for and the environment it would be placed in. Future work will be focused on the effect of different machining techniques, such as diamond turning, and material selection. The optical property changes due to the deformation under thermal loading will also be studied.

#### ACKNOWLEDGMENTS

The authors acknowledge the financial support of the National Science Foundation through grant number DMR- 0423914.

#### References

- [1] G. Beadie, James S. Shirk, A. Rosenberg, Paul A. Lane, E. Fleet, A. R. Kamdar, Y. Jin, M. Ponting, T. Kazmierczak, Y. Yang, A. Hiltner, and E. Baer, 2008, "Optical properties of a bio-inspired gradient refractive index polymer lens," *Opt. Express* **16**, 11540-11547.
- [2] Song, Hyunmin, Kenneth Singer, Yeheng Wu, Juefei Zhou, Joe Lott, James Andrews, Anne Hiltner, Eric Baer, Christoph Weder, Robert Bunch, Richard Lepkowitz, and Guy Beadie, 2009, "Layered Polymeric Optical Systems Using Continuous Coextrusion", *Nanophotonics and Macrophotonics for Space Environments III*, August 2009, San Diego, CA, USA.
- [3] ANSYS, Inc., Canonsburg, PA
- [4] Polimeri Europa. "Polimeri Europa Edistir RCL 600 Polystyrene." *MatWeb*. MatWeb, LLC. Web. 1 June 2011.  
<<http://www.matweb.com/search/DataSheet.aspx?MatGUID=812327498deb4da28a99fa200dcc0524&ckck=1>>.
- [5] "Material Properties of PS (hips), Commodity Polymers | Polymers Data Sheets." *Mechanical and Physical Properties of Materials | Matbase - Material Properties Database*. Web. 08 June 2011. <<http://www.matbase.com/material/polymers/commodity/ps-hips/properties>>.
- [6] "Poisson Ratio." *The Engineering ToolBox*. Web. 08 June 2011.  
<[http://www.engineeringtoolbox.com/poissons-ratio-d\\_1224.html](http://www.engineeringtoolbox.com/poissons-ratio-d_1224.html)>.
- [7] "LG Chemical EH910 PMMA, General Purpose Grade for Extrusion." *MatWeb*. MatWeb, LLC. Web. 08 June 2011.  
<<http://www.matweb.com/search/DataSheet.aspx?MatGUID=ceba58327107472785344b105cde502c&ckck=1>>.
- [8] "Material Properties of PMMA, Commodity Polymers | Polymers Data Sheets." *Mechanical and Physical Properties of Materials | Matbase - Material Properties Database*.

Web. 08 June 2011.

<<http://www.matbase.com/material/polymers/commodity/pmma/properties>>.

[9] "PMMA." *MIT - Massachusetts Institute of Technology*. Web. 08 June 2011.

<<http://www.mit.edu/~6.777/matprops/pmma.htm>>.

[10] "Schott N-BK7 Glass." *MatWeb*. MatWeb, LLC. Web. 07 June 2011.

<<http://www.matweb.com/search/DataSheet.aspx?MatGUID=a8c2d05c7a6244399bbc2e15c0438cb9&ckck=1>>.

[11] "Convection Heat Transfer." *The Engineering ToolBox*. Web. 10 June 2011.

<[http://www.engineeringtoolbox.com/convective-heat-transfer-d\\_430.html](http://www.engineeringtoolbox.com/convective-heat-transfer-d_430.html)>.

[12] "Friction and Coefficients of Friction." *The Engineering ToolBox*. Web. 10 June 2011.

<[http://www.engineeringtoolbox.com/friction-coefficients-d\\_778.html](http://www.engineeringtoolbox.com/friction-coefficients-d_778.html)>.

**Reach for the Stars  
(Undergraduate Research Partnered with NASA)**

Singli Garcia-Otero, Ph.D.  
Department of Engineering  
Virginia State University  
Petersburg, VA 23806  
804.524.8989 X 1126  
Fax: 804.524.6732  
[sgarcia-otero@vsu.edu](mailto:sgarcia-otero@vsu.edu)

E. Sheybani  
Department of Engineering  
Virginia State University  
Petersburg, VA 23806

Eduardo Garcia-Otero  
Department of Engineering  
Virginia State University  
Petersburg, VA 23806

# Reach for the Stars (Undergraduate Research Partnered with NASA)

Singli Garcia-Otero, Ehsan Sheybani, and Eduardo Garcia-Otero

## Abstract

The demand for diversified qualified science, technology, engineering, and mathematics (STEM) graduates has increased dramatically in recent years, especially with the retirement of baby boomers <sup>[1]</sup>. Therefore, the nation is facing a serious challenge in educating sufficient numbers of women and underrepresented minorities in the STEM fields to meet the demands of the scientific community. Recruitment and retention are important ways to increase graduation of women and underrepresented minorities. This paper concentrates on retention.

There have been many studies on low retention rates among women and underrepresented minorities in STEM disciplines and different conclusions have been drawn <sup>[2][3][4]</sup>. At Virginia State University, the most important factor for retaining students is the students' interest and motivation. The students need to be interested in STEM, and need to be motivated to perform all of the work necessary to complete a STEM degree.

In order to excite and increase the students' interest and motivation, VSU (Virginia State University) and Louisburg College (LC) partnered with NASA to create a summer internship at Goddard Space Flight Center (GSFC), where eight undergraduates worked with NASA scientists on advanced electrical aeronautic projects. This paper documents the impact that this exciting partnership is having on the students.

## Background

### Virginia State University (VSU)

VSU is a Land Grant institution founded in 1882, located in Petersburg, VA, and is one of 104 Historically Black College and Universities (HBCU) in the United States. Approximately 95% of its more than 5,000 students are African American.

### Louisburg College (LC)

Louisburg College is a private, co-educational, two-year residential college (the only two-year residential college in North Carolina, and one of only a handful in the United States). Founded in 1787, it is associated with the United Methodist Church, and offers three Associate degrees to its graduates: Associate in Arts, Associate in Science, and Associate in Science in Business. The school has an enrollment of approximately 700 students, including 70% African.

Due to very limited advanced research opportunities for minorities in HBCUs, there is a scarcity of underrepresented minority engineers and scientists pursuing successful research careers in STEM. A serious national shortage of well-trained underrepresented minority engineers and scientists exists. Well-trained underrepresented minority engineers and scientists can conduct independent engineering research, can focus research efforts on

the disproportionate lack of technical achievement in minority populations, and have cultural perspectives that are essential to the successful conduct of many forms of research involving minority populations.

### **Partnership between VSU, LC & NASA**

In 2010, Virginia State University and Louisburg College were funded by NASA-CIPAR (Curriculum Improvement Partnership Award for the Integration of Research) for a project named "Establishing an Undergraduate Interdisciplinary Curriculum Incorporating NASA Related Research." One of the objectives of the project is to recruit and retain young women and underrepresented minorities in STEM disciplines (especially in NASA-related geospatial science and technology) through the education and research components of an interdisciplinary curriculum, and specifically to motivate and encourage Louisburg College students to pursue and complete a four-year degree in STEM degrees at VSU or other undergraduate colleges/universities. The ultimate goal is to increase the U.S. base of women and underrepresented minorities in NASA-related STEM professional level careers.

One of the components of the project is to involve students in NASA-related research through summer internships at NASA research centers such as GSFC (Goddard Space Flight Center).

In Spring of 2011, we invited a NASA scientist/engineer/mentor to give a talk to the students at VSU about NASA-GSFC. More than thirty VSU engineering students were interested in the internship. The five VSU students selected to participate in the internship.

### **Internship in GSFC (Goddard Space Flight Center)**

During summer 2011, 5 VSU and 3 LC students spent 8 weeks at GSFC and conducted 5 different research projects: Radar Signal Processing, FPGA Programming, Test Antenna in The Antenna Anechoic Chamber, Characterize a Compact Superconducting Channelizing Band-Pass Filter, and monitor the health of the riparian buffer zone along the Tar River.

The minority students gained valuable career experiences through the summer research internships which included high tech undergraduate research opportunities in NASA-related engineering and science fields. Following are some quotes from the students:

- Now that I know how to research and understand the concepts I need to know, nothing will stop me from learning.
- The days are coming closer and closer to an end here at NASA. I have had such a good experience here and have learned much...
- ... I finally see how it feels to be a scientist; working long hours running tests only to have all of them fail. I realize now that I did not fail; I simply found a way how not to build a control box....
- This time here at Goddard has been very exciting and informative. I got a chance to see how engineers work in such an important facility..... It is going to be a bittersweet feeling leaving here after this upcoming week.
- The most important thing I have learned is that everything done at NASA cannot be

learned by reading a textbook. To open up your mind and explore new possibilities, you have to think outside the box. The things I learned at NASA, everyday people don't even talk about them because they can't even imagine them.

- I was interested in the things that NASA does. I wanted to gain experience in my field and this was a perfect opportunity to work with some of the best Engineers around. I learned how certain things are proposed and done. I witnessed how Engineers operate in the workforce.
- The most important thing I learned at NASA is to read. Plenty of times I was asked questions with the answer directly in my face, but I had not yet read what was in my face.

## **Impact of Project**

This is only the first year of our project, but the impact is tremendous. Having gained high level experience and expectations at NASA Labs, the NASA summer internship students also gained a very positive attitude towards learning more at school. The new improved attitude towards learning has created a very positive atmosphere in the classroom for their classmates, as well as for teachers. These students now understand the need for grasping the hard concepts in math, science, engineering and technology. By talking about their experiences at NASA, these students are also motivating the rest of the class and encouraging them to try such internship opportunities. These students also continue their research in the Interdisciplinary Data Processing Lab at VSU. Some of these students plan to extend their research as senior design projects.

## **The Future**

We will send more students to the NASA center the next two summers, and will involve more students in the research. The students will bring back the NASA culture to the classroom, and we believe the retention rate will increase

## **Acknowledgment**

The authors would like to acknowledge NASA CIPAIR grant (award# **NNX10AU70G**) for the for the financial support.

## **References**

1. U.S. Department of Labor, [ftp://ftp.bls.gov/pub/special.requests/ep/ind-occ.matrix/occ\\_pdf/occ\\_17-2000.pdf](ftp://ftp.bls.gov/pub/special.requests/ep/ind-occ.matrix/occ_pdf/occ_17-2000.pdf)
2. Felder R., Felder G., & Dietz E., (2002) "The Effects of Personality Type on Engineering Student Performance and Attitudes," *Journal of Engineering Education*, 91(1), 3-17.
3. Flemming L., K.Engerman, & D. Williams, (2006) "Why Students Leave Engineering: The Unexpected Bond," American Society for Engineering Education.
4. Seymour, E., & Hewitt, N. (1997) "Talking About Leaving: Why Undergraduates Leave the Sciences," Boulder, Colorado: Westview Press.
5. Barger, M., Goff, G., & Rogers, H. (2003) "Bridging a Gap: A.S. to B.S. Articulation in Florida," American Society for Engineering Education.



6. Newman, R., Munukutla, L., & Robertson, J. (2002) "Building Bridges with Community Colleges, Partnering for Educational Success," American Society for Engineering Education.

**Engineering Education OR Just Education**

Keith M. Gardiner  
Lehigh University  
Center for Manufacturing Systems Engineering  
200 West Packer Avenue, Bethlehem, PA 18015  
[kg03@lehigh.edu](mailto:kg03@lehigh.edu) 1-610-758-5070

# Engineering Education OR Just Education

KEITH M. GARDINER

Lehigh University

Center for Manufacturing Systems Engineering

200 West Packer Avenue, Bethlehem, PA 18015

[kg03@lehigh.edu](mailto:kg03@lehigh.edu) 1-610-758-5070

## Abstract

“Engineering Education for the Next Decade,” but let’s stretch and think farther out. Various national and international projections address 2030 and even 2050. Think of 2030, two decades will have flown by, or looking back we may reflect on 1990. Times were very different then and will likely be even more different in the future. Today there are new companies, new ‘toys,’ high technology cellular devices, marvelous digital cameras, and politically significant social movements all catalyzed by these innovations. Have our educational methods changed in parallel?

What of 2031? The US will likely no longer be a primary ‘top-of-the-heap’ nation; what is the U.S. prognosis? In particular, education practices have not experienced major curricula rearrangements since the traumas of Sputnik. U.S. science, technology, engineering and mathematics (STEM) rankings are below world-class. Our students today are rather different animals than those of just a few decades ago.

It is time to re-assess what is required of the engineering education community. Industry groups are continually lamenting “critical skills shortages” and it is obvious from the levels of rhetoric in Washington and our media that there are major and persisting deficiencies in our broader education systems. Current topical debates reveal woeful levels of scientific and technological illiteracy leading to the conclusion that a high priority is not necessarily the improvement of ‘engineering education’ but a major overhaul of the entire system to match productivity demands that will be placed on our future workforce. The need for dramatic change is explored.

## Introduction

Aerospace, automotive and energy industries are exceptionally busy making forecasts out to 2030 and even, in some cases, to 2050. In fact, the bulk of their products possess remarkably lengthy life cycles customarily accompanied by Greenhouse Gas (GHG) emissions. So as we consider engineering education for the next decade, why not stretch and aim our discussions and projections for a couple of decades or more? Where will our nation and the world be in 2031? What will be the issues, opportunities, pressure points, problems, requiring our best engineering solutions both nationally and globally over this horizon? The engineers that we are educating today should be engaged in the productive periods of their careers. What should we be doing today to prepare them adequately to conquer the manifold challenges that their world will face? How may these challenges differ from those of today, and how should their preparation be adjusted?

## Appreciating the Recent Past

Before projecting forward into the imaginative postulated worlds of the likes of Huxley, Verne, Vonnegut and Wells, to name but a few, it is wise to glance backwards. The United States today is thought of as among the ranks of the most productive and prosperous nations on the planet. In 1990; the United States population was 249.6 million (313.2 M today). Tim Berners-Lee was developing the principles for the internet; Amazon, Facebook and Google were hardly thought of, the Dow was below 2700 (now over 11,000) and Boeing was in the throes of developing the 777. Today we have many new companies, new 'toys,' high technology cellular telephones and personal digital assistants (PDAs) that are becoming 'smart' enough to communicate emotions, marvelous digital cameras, 'cloud' computing and politically significant social movements catalyzed by many of these innovations. As a nation we also possess many problems, not forgetting a frequent plea for greater skills, and more especially 'soft skills' in the workforce.

One of the first steps in assessing any problem is to discover analogs and establish benchmarks.

How are other nations performing and dealing with similar problems although possibly with different cultural, economic and social constraints and customs? Following very many searches a massive array of data was assembled. Factors such as 'Quality-of-Life,' 'Ease of Doing Business,' various governmental expenditures expressed as a percentage of 'Gross Domestic Product (GDP) per capita,' and, importantly engineering graduation rates. A commendable approach by 'The Economist' drew attention early in this research – "The World in 2005, Quality-of-Life index – The Economist Intelligence Unit's quality-of-life index."<sup>1</sup> Unfortunately this is now six years old, but so far, no successor report has become available from this source. This then was a starting point; using other data sources a list of ten countries with some affinities, relevance or similarities etc. with the United States was established. This was augmented more recently with input on the increasingly prosperous BRIC countries, Brazil, Russia, India and China. Primary sources for this data were OECD (Organization for Economic Co-operation and Development) web sites and the CIA Fact Book.<sup>2,3</sup>

## Comparative Prosperity

There are many ways for ranking countries and a confusion of data is available. "The Economist" offers a 'quality-of-life' index with the most recently available tabulation dating to 2005 that places pre-crash Ireland at the top with a score of 8.333 on a scale of 10. Switzerland, Norway, Luxembourg and Sweden follow closely. The United States earns a score of 7.615 and thirteenth position with Canada and New Zealand next. The BRIC group enters this list with Brazil (39/6.470), China (60/6.083), India (73/5.759) and Russia (105/4.796).<sup>1</sup> The scoring system attempts to go beyond relatively straightforward GDP including points for such factors as community life, family life, gender equality, material wellbeing, political freedom, and similar possibly culturally determined statistics

An alternative tabulation for 183 countries is published by the World Bank which ranks economies according to the 'Ease of Doing Business.' For June 2010 Singapore was top,

followed in rank by Hong Kong, New Zealand, United Kingdom, United States and Denmark; Ireland is ninth, Japan eighteenth, and Germany twenty-second. China is seventy-ninth one place ahead of Italy, Russia one hundred and twenty-third, Brazil one hundred and twenty-seven, and India one hundred and thirty-fourth.<sup>4</sup>

A surprise resource that also provided more insights and possible confusion was found in a magazine aimed at future emigrants called "International Living."<sup>5</sup> A complex scoring system rates countries based upon 'Cost of Living,' 'Leisure & Culture,' 'Economy,' 'Environment,' 'Health,' 'Infrastructure,' 'Risk & Safety,' etc. giving a rank and final score. Many countries in the developed world gained closely similar scores, but the Less Developed Countries (LDCs) are shown up significantly. Table 1 shows this list of fifteen countries ranked by the 2005 'QoL' and showing population, GDP per capita, ease of doing business ratings and the number of companies featured in the top one hundred from the Fortune Global 500 listing.<sup>6</sup> This latter factor and the GDP figures add re-assurance for the United States, and confirm our present strengths. GDP figures are for 2010 based on the CIA Fact Book.<sup>3</sup>

TABLE ONE							
Qual.Life Rank (1)	Country	Population	2010 GDP \$ (3) per cap	2010 Global Co's (6)	Business Ease Rank (4)	Internat. Qual.Life Score (5)	Living Qual.Life Rank (5)
1	Ireland	4,670,976	37,300		9	70	41
2	Switzerland	7,639,961	42,600	2	27	81	3
6	Australia	21,766,711	41,000		10	81	2
13	USA	313,232,044	47,200	29	5	78	7
14	Canada	34,030,589	39,400		7	72	9
15	New Zealand	4,290,347	27,700		3	79	5
17	Japan	126,475,664	34,000	11	18	70	36
25	France	65,312,249	33,100	10	26	82	1
26	Germany	81,471,834	35,700	11	22	81	4
29	UK	62,698,362	34,800	8	4	73	25
30	S. Korea	48,754,657	30,000	3	16	69	42
39	Brazil	203,429,773	10,800	1	127	70	38
60	China	1,336,718,015	7,600	6	79	56	97
73	India	1,189,172,906	3,500		134	58	88
105	Russia	138,739,892	15,900	2	123	54	111
	AVERAGES	242,560,265	29,373			71.6	

The table shows some good news upon which to base future optimism about the United States. Among the 'Global 500' companies listed by Fortune magazine by revenues for 2010 there are 29 in the top one hundred with US headquarters addresses, Germany and Japan rank next with just eleven apiece, France follows at 10, Britain with 8 and China 6. However when we examine an 'Industry Week'<sup>7</sup> list of the top one thousand publicly held manufacturing companies ranked by revenues for 2010/11 we find 37 Euro-based companies (inc. Russia), 31 in Asia (inc. Australia), and just 31 in the Americas (inc. Brazil). The operations in the 'Petroleum & Coal Products' category are strongly represented among those with highest revenues, with 'Electrical Equipment & Appliances' balancing 'Motor Vehicles' as next in line numerically. This doesn't augur well for efforts to reduce carbon emissions (But then horse manure was allegedly a very huge issue at the start of the last century).

Commercially then we can conclude that the US is trading alongside industrial operations that are approaching, or have reached some level of parity. Nationally we may not be the economically, or industrially healthiest ‘fish in the ocean,’ but we rank very highly among countries that maybe striving to join us as peers. In fact, nations and their hegemonies are being superseded by conglomerates, and multinationals. Already Wal-Mart has more employees than many smaller member countries of the United Nations. The Gross Domestic Product (GDP) of several US cities and states exceeds that of many small nations. Competitors and emulators are arriving at the global table – commerce and international trade can only increase (along with population). It is worth noting that the ‘Industry Week’ tabulation gives no indication of degrees of governmental control or investment in their respective national ‘industrial treasures.’

### Engineering Education

Expressed simply a nation’s prosperity ultimately depends on what it grows, makes or mines – this has been largely de-emphasized in many western countries. Agri-businesses have flourished, along with genetically modified (GM) or engineered (GE) developments affecting both high volume crops and the mass-processing of animals and fish. Manufacturing in many countries has been diminished, but is now tending to be recognized as a necessary component to provide jobs, prosperity and wealth generation.<sup>8</sup> Education and the nurture of a skilled workforce are of vital importance. Table 2 displays the record for the fifteen countries based upon OECD data (plus the most recent data from the ‘Programme for International Student Assessment (PISA)).<sup>2</sup>

<b>EDUCATION</b>					Higher Ed. % Pop.	Educ. \$ % GDP 2007	Ranks		
<b>TABLE TWO</b>							OECD	PISA	Ref. 2
Sorted by % of Engr Degrees in total of all degrees							Math	Science	Reading
Rank		All Degrees	Engr.Degr.	Engr.%					
60	China	1,726,674	575,634	33.3	0.13	3.3	1	1	1
30	S. Korea	270,546	68,601	25.4	0.55	7.0	4	6	2
17	Japan	558,184	96,675	17.3	0.44	4.9	9	5	8
25	France	285,238	39,409	13.8	0.44	6.0	22	27	22
26	Germany	267,597	34,207	12.8	0.33	4.7	16	16	20
2	Switzerland	25,254	3,056	12.1	0.33	5.5	8	15	14
105	Russia	1,335,528	134,392	10.1	0.96	7.4	n/a	n/a	n/a
1	Ireland	25,865	2,544	9.8	0.55	4.7	n/a	20	21
6	Australia	171,582	12,357	7.2	0.79	5.2	15	10	9
14	Canada	176,910	12,369	7.0	0.52	6.1	10	8	6
29	UK	319,260	19,900	6.2	0.51	5.8	28	16	25
15	New Zealand	31,737	1,939	6.1	0.74	5.9	13	7	7
39	Brazil	677,154	31,953	4.7	0.33	5.2	n/a	n/a	n/a
13	USA	1,502,922	68,227	4.5	0.48	7.6	30	23	17
73	India	750,000	29,000	3.9	0.06	3.3	n/a	n/a	n/a
Average						5.5			

The deficiencies of the United States with respect to STEM (Science, Technology, Engineering and Mathematics) education is revealed with embarrassing clarity. As a partial compensation the results for China are admittedly from restricted testing in Shanghai and

other major cities and do not represent the whole country. Additionally, to some extent, it may be misleading to quote costs as percentages of GDP per capita; these numbers are greatly affected by population and social factors. Nevertheless, it is valid to compare numbers of engineering degrees as a percentage of all degrees granted, and of the fraction of these 'engineers' as a proportion of the whole population. The published rankings and scores in respected international surveys are also inarguable. The United States vaunted strengths in education, and our degree granting institutions is not reflected by the numbers. Percentage of engineering degrees for 2006 (or more recent year) per OECD<sup>2</sup> among all other degrees show China at 33%, S. Korea 25%, Japan 17%, France and Germany with above 12%, Russia 10% and the United States 4.5% next to Brazil and just above India 3.9%. Another column shows the percentage of the whole population securing degrees, the US at 0.48% is not very different from similar countries, whereas China's multitudes count 0.13%

## Healthcare

An important component of prosperity and quality-of-life is healthcare, here there are large differences between costs and results across different countries' systems. The United States leads in both proportion of GDP devoted to healthcare at 17.4%, re-expressed as \$7960 per capita accompanied by life expectancy at birth of 78.2 years; whereas Germany is shown at 11.6%, \$4218 and 80.3 years. Table 3 shows the data collected by OECD for 2009.<sup>2</sup> Another source, The Economist<sup>9</sup> offers a more recent narrative in an article published in March, 2011. Figure 1 shows that Chileans enjoy similar life expectancy at birth as do Americans, this is some four years less than the Japanese but with large differences in costs per person. Seventy years ago in 1940 the health of Americans was superior to that of war-ravaged Europeans – the average 65-year-old male had a life expectancy of 12 years to just 77. In the UK and France comparable figures were respectively 11 and 10 years. For 2011 the expectancies are France 18 years, with UK and US at 17 years.

HEALTH OUTCOMES		TABLE THREE			Int.Liv.
Qual. Life Rank (1)	Country	% GDP Health (2)	Health \$'s/cap.	Life exp. birth (2)	Qual. Life Rank (5)
13	USA	17.4	7960	78.2	7
25	France	11.8	3978	81.0	1
26	Germany	11.6	4218	80.3	4
2	Switzerland	11.4	5144	82.3	3
14	Canada	11.4	4363	~80	9
15	New Zealand	10.3	2983	80.8	5
29	UK	9.8	3487	80.4	25
1	Ireland	9.5	3781	80.0	41
6	Australia	~8.7+	~3600	81.6	2
17	Japan	~8.5	~2878	~83	36
39	Brazil	7.5	n/a	72.5	38
30	S. Korea	7.0	1980	~80.3	42
105	Russia	5.3	n/a	66.3	111
73	India	4.9	n/a	66.8	88
60	China	4.5	n/a	74.7	97

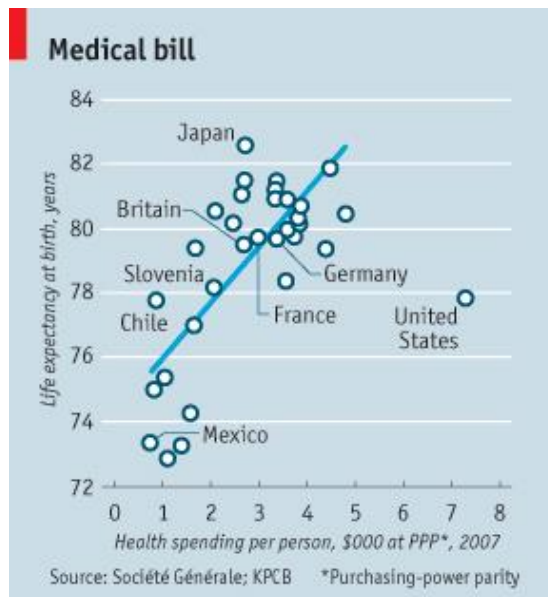


Figure 1 (Ref. (9))

“Health costs and life expectancy,” from “The Economist,” blog Mar 3<sup>rd</sup> 2011

## Logistics

Logistics are of critical importance in a globally competitive marketplace. Transporting goods, materials and products in ‘standardized’ containers started slowly in America in the fifties and did not blossom internationally until 1966 with service from the US to Rotterdam. Today 90% of non-bulk cargo travels in containers.<sup>10</sup> Looking outward from the US there is perception that the US trades vigorously with China and that shipload after shipload reaches US ports full of Chinese and other Asian manufactured goods. US trade with Asian countries is vigorous, but it must be realized that inter-Asian trade is of much greater volume, Table 4 shows that there are high volumes of business involving countries other than North America. Nationally we remain a very important factor, intermediary, designer, manufacturer, coordinator, consumer, and possess very many niche areas of global commerce. Our systems and initiatives are copied and envied but we must recognize ourselves that we are not necessarily any longer the world’s best, the greatest, the ‘mostest’ etc. It needs to be emphasized that there is an appreciable volume of global commerce and trade outside North America. Certainly much of it likely involves US-based multinationals that may repatriate some revenues. Companies such as GM are on the threshold of producing more cars in China than they do in the U.S. or Europe. Thus, nationally we rank highly in many areas but there are many countries that we can learn from.

<b>TABLE FOUR</b> Ref (10) 2009	
Intercontinental Container Traffic	
Intra - Asia	44.0
Asia - N. America	11.5
Asia - Europe	11.5
N. America - Asia	6.5
Europe - Asia	5.4
Intra - Europe	7.0
"20-foot" equivalent units (Millions)	



## Discussion

Just as the details and subtleties of 2011 problems could hardly be contemplated twenty years ago, we should forswear any notion of defining future problems aside from those that are already, and rapidly becoming apparent. We must accept ambiguity and prepare our students to be problem solving intellectual and pragmatic ‘commandoes.’ Notably both today and in the future the United States will not necessarily remain as a solitary primary ‘top-of-heap’ nation. Notwithstanding this our gross domestic product (GDP) is the highest in the World per capita at \$47.2K; almost 10% greater than second place Switzerland. Our relative prosperity is declining slowly, our exports still rank highly thanks to aerospace, agriculture and silicon valley (to simplify), and imports flow almost without pause. Our quality-of-life rates lower than several nations in Europe, our healthcare expenditures are the highest in the world but give us less than stellar results on a per capita basis, and education statistics present a similarly depressing picture.

On the education front, the US possesses many of the most vaunted institutions in the World and our curricula, accreditation procedures and concomitant research output are envied. Our system also continues to attract many foreign students notwithstanding high costs, accompanied by immigration, language and logistical barriers. But nevertheless industry leaders cannot find employees with the special skills and background knowledge that are required in the 21<sup>st</sup> century workplace. There are claimed deficiencies in “soft skills.” This is not unlike some of the acknowledged deficiencies in the engineering workforce in the late seventies and early eighties. Here the issues were defined by many task forces as requiring a broadening of the engineering curricula to include communication, business knowledge, teamwork abilities and IT competencies.<sup>11</sup>

Subsequently this ‘laundry list’ has been augmented as result of competitive pressures globally to include consideration of cultural and international factors. Many degree programs have developed compensatory ‘minors,’ cross- or inter-disciplinary options and graduate programs; these are exemplified at Lehigh with the cross-disciplinary graduate program leading to an MS in Manufacturing Systems Engineering that first welcomed students in 1984 and is now available on-line, and an Integrated Product Development Program with both graduate and undergraduate sections.<sup>12,13</sup>

Collaborative working in teams was a feature of the IBM Manufacturing Technology Institute that was established in Manhattan in 1981 to revitalize the old-style IBM manufacturing workforce.<sup>12</sup> During the next decade teamwork started to become a feature of the K-12 curriculum and several competitions such as FIRST (**F**or **I**nspiration and **R**ecognition of **S**cience and **T**echnology) for 9-12 grades in 1992, and a Future City Program for 6-8 grades in 1993 were inspired.<sup>14</sup> The imaginative and innovative skills that are unleashed in contests of these types should not be suffocated (and destroyed) by excessively prescriptive curricula. By 2000 teamwork was becoming pervasive in some few engineering courses and at several levels.

Overall subsequent improvement efforts have mostly amounted to tweaking what we have, packing more content into limited time and only really catering for students willing to explore topics beyond the customary disciplinary boxes and ‘silos.’ Sir Ken Robinson<sup>15</sup>

explores the fossilization of our curricula structure with persuasive rhetoric in YouTube pieces, on TED and convincingly in his book "Out of Our Minds." There is a need to step back, absorb the changes in communication, contexts, habits and available technologies to totally restructure curricula so as to equip our students to enter the contemporary and likely future workplace. Our students today are rather different animals than those of just a few decades ago. Admittedly, though, good students can survive our existing prescriptive curricula and become excellent contributors; but it is reasonable to postulate alternative approaches that may increase our STEM population.

### Summarizing

It is worth reflecting on the ideas of Confucius/Xun Xi in 450 B.C. and striving to place greater reliance on Project-Based (or 'experiential') Learning (PBL):

*"Tell me, and I will forget. Show me, and I may remember. Involve me, and I will understand."*

Senior Design projects seem satisfactory for students that survive to become seniors. However, if the whole curriculum could be inverted to offer major ambiguous exciting design and research projects to first year students then the boring rigors of 'standard or routine' courses would possibly be more readily tolerated. Preferably though it could be found possible to deliver learning modules as needed with sufficient content to solve problems and detail issues as they arise and thus afford significant 'active' learning experiences.

Our existing curriculum structure can be traced back to the industrial revolution, this age also stimulated the growth of unions and guilds. Our industrial activities became more complex, content, standards, constraints and a variety of organizational and management techniques developed. Technologies grew in parallel; the individual slate and chalk was superseded by paper and pencil, blackboards and movie clips by Power Point, and YouTube. In the main content remained prescriptive, standardized and was augmented, trimmed, expanded to mention latest trends: And also most importantly to conform to the requirements of accreditation, the professional silos and the US News and World Report rankings. Efforts to innovate academically are doomed to only partial success when constrained by standardization, and discipline-related habits and thought processes.<sup>8</sup>

Prior papers delivered to ASEE Regional conferences have discussed curriculum development at length.<sup>8</sup> These can be summarized briefly as defining a need to think 'outside the box' and starting again with a redefinition of the education problem and understanding of the differences in technologies and society in the last three decades and more. Sir Ken Robinson presents these ideas most eloquently and repetition would be redundant.<sup>15</sup> What has to be addressed are the organizational barriers to starting these processes and their implementation. As individuals we can empower students in our own classrooms, and digitally, to handle ambiguous 'open-ended' challenges, but there is need for wider and more systemic adoption of these approaches. There are some remarkable contrasts between the United States and all of the countries tabulated above that we can learn from. In particular, the example of Germany is worthy of deep contemplation. Overall they seem worthy of some emulation in their regard for science, technology, social welfare, and other factors.<sup>16</sup> Their economy may be of some concern, but then whose isn't?

In the United States in 2011 our collective imaginations are also severely constrained not only by the aforementioned factors but by an evident and woeful deficiency in the levels of scientific and technological awareness of the administrators, communicators, politicians and leaders of our communities – in short by ourselves.<sup>17</sup> We are, as a society, collectively and willfully ignorant, unable to accept, appreciate or understand what could be accomplished by overall utilization of sane applied science and sustainability objectives. Our media, in the main, collaborate in exacerbating these problems in the interests of satisfying their advertisers (who provide much of their revenues). Are we trapped? No! Forums like this – discussions among ourselves and in our individual classes will eventually bring some ameliorating changes. However, our students will face the problems that we knowingly leave behind and they will be solved albeit belatedly. The ‘sky is not falling’ – not quite yet; but there is need for strict logical and science-based management of global resources, particularly with respect to food and water, carbon-footprints, infrastructure, sustainability and all the problems and discoveries that all these issues entrain. The future is bright with promise and possibilities, but realization may bring some discomforts as a global and pervasive economic social thermodynamic evolution takes place.

## Conclusions

What is the prognosis for the United States? Overall the tabulated data shows that the U.S. is no longer the pre-eminent world leader and example that was often imagined. Nevertheless our major multi-national enterprises are among the leaders of globalization and many receive a major proportion of their revenues from off-shore. They are providing jobs, increasing market share and enhancing prosperity globally. Meanwhile on the home front education, healthcare and many intangible quality-of-life factors are not producing results at levels befitting our aspirations, or reputation.

Thus, we should not focus our concerns solely on ‘engineering education’ but on developing an education paradigm whereby engineering, science and appreciation for modern technologies are pervasive throughout the population and embedded and respected as true ‘liberal arts.’<sup>16</sup>

Changing our collective approach to education at all levels is an important objective. Middle school age kids have fertile imaginations, they can be most imaginative and innovative as shown by many competitions. Our whole pedagogical structure must be enlivened and enriched to provide an educational regime that will awaken and satisfy the natural scientific curiosity of these future students and citizens. Concomitantly we must collectively challenge the current abysmal scientific and technological competencies of our whole society and stimulate ‘moon landing-type’ levels of excitement, interest and understanding throughout our citizenry. We must make these efforts throughout our academic structures and escape our silo-boxes that we so willingly shelter behind. The issues that we face are education overall and not just ‘Engineering Education.’

## Acknowledgments

These thoughts and their development owe much to discussions with my wife, Bernice, and to the comments, input and suffering of students in diverse classes. Once students understand and trust their being empowered learners they perform magnificently and we all learn.

## References

1. "The Economist Intelligence Unit's quality-of-life index; The World in 2005," The Economist Newspaper Limited, London, accessed Sept. 2011 via [http://www.economist.com/media/pdf/QUALITY\\_OF\\_LIFE.pdf](http://www.economist.com/media/pdf/QUALITY_OF_LIFE.pdf)
2. Organization for Economic Co-operation and Development (OECD) web site accessed Sept. 2011 via [www.oecd.org](http://www.oecd.org) and [http://www.oecd.org/document/0,3746,en\\_2649\\_201185\\_46462759\\_1\\_1\\_1\\_1,00.html](http://www.oecd.org/document/0,3746,en_2649_201185_46462759_1_1_1_1,00.html)
3. "CIA – The World Factbook," web site accessed Sept. 2011 via <https://www.cia.gov/library/publications/the-world-factbook/>
4. "Ranking of Economies - Doing Business – World Bank Group," web site accessed August 2011 via <http://www.doingbusiness.org/rankings>
5. "International Living, 2010 Quality of Life Index," magazine website accessed August 2011 via <http://www1.internationalliving.com/qofl2010/>
6. Fortune "Global 500," an annual ranking of the world's largest corporations, July 25, 2011, Vol. 164, No. 2, p. F-1 and on the web at <http://money.cnn.com/magazines/fortune/global500/2011/index.html>
7. "Industry Week 1000," a report on the 1000 largest publicly held manufacturing companies based on revenue, web site accessed August 2011 and subsequently via <http://www.industryweek.com/research/iw1000/2010/iw1000rank.asp>
8. Gardiner, K. M., "Future Directions for Manufacturing," Proceedings, R3MEMCON, SME East Coast Region 3 Annual Conference, Lehigh University, October 10-11, 2003 (CD). Amended version delivered to a seminar, Intelligent Manufacturing Systems - Global Education for Manufacturing (IMS-GEM), Tokyo, Nov. 1st, 2003, published in proceedings. Also Gardiner, K. M., et al, "Education for the Future Workforce," Proceedings, ASEE Mid-Atlantic Section, Spring Conference 2009, Loyola College, MD. (CD)
9. "Health costs and life expectancy: Paying through the (surgically altered) nose," The Economist, Buttonwood Blog, March 2011 web site accessed August 2011 via [http://www.economist.com/blogs/buttonwood/2011/03/health\\_costs\\_and\\_life\\_expectancy](http://www.economist.com/blogs/buttonwood/2011/03/health_costs_and_life_expectancy)
10. Stark, G. and Michael, D., "What the West Doesn't Get About China," Harvard Business Review, June 2011, accessed via <http://hbr.org/2011/06/what-the-west-doesnt-know-about-china/ar/1>
11. See, for example: "Visionary Manufacturing Challenges for 2020," National Academy Press, Washington, 1998; also "Manufacturing Education Plan: 1999 - Critical Competency Gaps, Industry Updates Competency Gaps among Newly Hired Engineering Graduates," Society of Manufacturing Engineers, Dearborn, MI., 1999. [Also relevant "The Engineer of 2020" (NAE 2004) and ASEE Prism, Jan. 2005.]
12. Gardiner, K. M., "The Pedagogic and Technological Evolution of a Manufacturing Systems Engineering (MSE) Graduate Program," Paper 1561, Proceedings, 38<sup>th</sup> ASEE/IEEE Frontiers in Education Conference, Oct. 23-25, 2008, Saratoga Springs, NY (CD).
13. Integrated Product Development Program, Lehigh University, web site at <http://www.lehigh.edu/ipd/>
14. Gardiner, K. M., "The Future City Competition – A Successful Stem Experience for Middle School Students," Proceedings, ASEE New England Section, Spring Meeting, University of Rhode Island, April 21, 2007 (CD); see also <http://www.futurecity.org/>
15. Robinson, Sir Ken, "Out of Our Minds – Learning to be Creative," Revised Edition (Wiley) 2011, Capstone Publishing Ltd., Chichester, U. K., ISBN 9781907312472. Also valuable video clips can be

found at YouTube (Oct. 14, 2010 – 12m.) or TED (June 26, 2006 – 19m.)

[www.youtube.com/watch?v=zDZFcdGpL4U](http://www.youtube.com/watch?v=zDZFcdGpL4U)

[www.ted.com/talks/ken\\_robinson\\_says\\_schools\\_kill\\_creativity.html](http://www.ted.com/talks/ken_robinson_says_schools_kill_creativity.html)

16. Slusarczuk, Marco, “The Germans Have a Model The United States Could Use To Revive Manufacturing And Its Middle Class,” *Manufacturing & Technology News*, September 30, 2011, Vol. 18. No. 15. German apprentice schemes and a Michigan training system receive mention in Bennett, D., “Do The Unemployed Get A Second Act?” *Bloomberg Businessweek*, Sept. 19 –Sept. 25, 2011, pp. 64-70.
17. Hanley, Charles J., “The American 'allergy' to global warming: Why?” *Research & Development*, e-newsletter link Sept. 26 via [www.rdmag.com/](http://www.rdmag.com/)

## **Assessment of Student Attitudes and its Impact in a Hands-On Programming Model for the Introductory Programming Course**

Sheikh Ghafoor, Stephen Canfield, Michael Kelley, Tristan Hill  
Tennessee Technological University, Cookeville, Tennessee

### **STEPHEN CANFIELD**

Stephen Canfield is a professor in the Department of Mechanical Engineering at Tennessee Technological University. He received his Ph.D. in mechanical engineering at Virginia Tech in the field of parallel architecture robotics. His research interests include robot kinematics and dynamics, topological optimization of compliant manipulators and in-space mechanisms active student learning and undergraduate student research

### **SHEIKH GHAFUOR**

Sheikh Ghafoor is an assistant professor in the Department of Computer Science at Tennessee Technological University. He received his Ph.D. in Computer Science from Mississippi State University. His current research is in autonomic resource management for high performance computing environment, programming model for parallel adaptive applications, and fault tolerant computing. He is also engaged in research in of computer science education.

### **TRISTAN HILL**

Tristan Hill is master's student in the Department of Mechanical Engineering at Tennessee Technological University.

### **MICHAEL KELLEY**

Michael Kelley is a master's student in the Department of Computer Science at Tennessee Technological University.

# Assessment of Student Attitudes and its Impact in a Hands-On Programming Model for the Introductory Programming Course

Sheikh Ghafoor<sup>1</sup>, Stephen Canfield<sup>2</sup>, Michael Kelley, Tristan Hill  
Tennessee Technological University, Cookeville, Tennessee

## Abstract:

Many students enter engineering programs as a result of a hands-on experiences that they have had directly or indirectly in their past. The freshman-level programming course provides an ideal opportunity to build students' perceptions of engineering, creativity, and notions of how things work. Ideally, students will begin learning programming in an environment that matches their notions of engineering, that engineers design systems to control the world around them, and then later move to solving advanced models that describe how the world works. A recent model has been implemented in the college of engineering at Tennessee Tech (TTU) to base the initial programming experience on hardware in the loop approach where the programming target is a micro-controller. This course has been offered in both C/C++ and Matlab programming language.

From multiple previous implementations, we see that the students that engaged in the hands-on, hardware-based programming activities reported a more positive early experience with programming and its relation to the engineering curriculum relative to their comparison-group peers. The students participating in the project also reported improved confidence in their ability to learn and use programming and note its importance in their engineering studies. However, we have observed in both the treatment and control group that the students' change in attitude toward programming in some cases is neutral or negative. This result was not expected and did not correlate directly with the degree of engagement with the model. This paper will explore these findings in greater detail. It will provide an overview of the model and the expected outcomes in student attitudes towards programming. It will present the findings in student attitude resulting from three semesters-worth of project implementation. Several potential factors that led to these results will be presented. The paper will conclude with the implications of these findings on planning assessment tools for entry-level programming experiences based on student attitudes.

## 1. INTRODUCTION

Many students enter engineering programs as a result of hands-on experiences that they have had in the past. However, engineering programs often do not provide enough practical experiences early in the curriculum [1]. The freshman-level programming course provides an opportunity to build on incoming student's perceptions of engineering and the tools engineers use. The traditional entry-level programming course for engineers is based on learning C, Fortran or Matlab to solve numerical algorithms associated with common engineering models. Any use of a computer as a device to control physical events is generally contained in upper

---

<sup>1</sup> Author for correspondence: Department of Computer Science, Tennessee Technological University, 110 University Drive, Cookeville, TN 38505, 931-372-3482, [sghafoor@tntech.edu](mailto:sghafoor@tntech.edu)

<sup>2</sup> Author for correspondence: Department of Mechanical Engineering, Tennessee Technological University, 115 West 10<sup>th</sup> St., Cookeville, TN 38505, 931-372-6359, [SCanfield@tntech.edu](mailto:SCanfield@tntech.edu)

level courses. While creating programs to solve numerical analysis problems is an important tool for engineers, we contend that the current model is inverted based on a pedagogical basis. Ideally, students would begin learning programming in an environment that matches their notions of engineering; that engineers design systems that control the world around them; and then later move to solving advanced models that describe how the world works. Based on recent advances in microcontroller hardware, associated programming environments and many examples of integrating programming with hardware in the loop for upper classman engineering, the authors propose to alter the context in which programming is taught to engineering students at TTU. The course has been implemented as an initial programming experience based on a hardware-in-the-loop model, retaining the C or Matlab programming standard but using as a programming target a micro-controller (a computer designed to interface with the outside world) to interface to simple physical systems. This is intended to result in a programming experience that will demonstrate one way in which engineers use computers and be appropriate for early understanding of engineering.

The program has been implemented over multiple semesters at TTU. An evaluation of the first implementation of this course is presented in [2]. The evaluation methods review in part student attitudes and perceptions about computer programming and how engineers use computers and programs to solve real-world problems. During the early implementation of the project and first assessment results, the student attitude data appeared to reinforce the authors' opinions of students' attitudes before and after the course; that students would be more positive about programming, its importance in engineering and the need to continue to learn programming during their education after the course. However, as survey data from subsequent courses based on this model were obtained, a different trend was observed that goes. This trend is illustrated and discussed further in this paper.

The remainder of this paper will proceed as follows. Section 2 will discuss some related work for the proposed model and assessment results. Section 3 will summarize the model and organization of the course. Section 4 will summarize the attitude survey findings and present a discussion on these results. The paper will end with concluding remarks in section 5.

## **2. DISCUSSION OF RELATED LITERATURE**

A review of related literature is presented in two areas: the first applies to the underlying basis of the model, and the second applies to an outcome from attitude surveys in similar contexts. First, a background for the model is presented. Applying pedagogically-based improvements to the engineering programming experience throughout the undergraduate program has seen significant attention in the literature. The greatest focus has been on modifying the approach to teaching engineering computing to freshmen (see for example [4-7]). One common theme is the use of computing tools (such as spreadsheets, Matlab or MathCAD [3-5,8]) as an alternative to high-level programming languages (C or Fortran). Other popular approaches have been in involving students to perform activities in a more realistic environment [9], and programming within the context of gaming [10]. The proposed hands-on programming model presented by Canfield et al., [2] focuses on a programming experience that is in a context appropriate for early engineering students by introducing MCU hardware as the direct programming target.

The proposed model [2] for improving the programming experience is designed around a principle of learning that are highlighted in How People Learn [11], and emphasized within a



context related to STEM education [12]. This principle is described in within the framework of the programming model as follows:

Students enter the engineering curriculum in general and the early programming course in particular with preconceptions about how engineering and computers work. In order to effectively develop them as successful engineers, their initial understanding must be engaged and developed to see the full picture of computers in engineering, which goes beyond the traditional desktop picture.

To illustrate this point consider the simple output control of an MCU (microcontroller unit). This programming experience allows students to relate many fundamental concepts in programming (variable definition, discrete nature of variables, memory type, and memory control) in an immediate fashion to the computer, the computer components and the program. For example, defining a variable (creating that variable in ram) can be tied to direct control of a series of LEDs attached to an output port of the MCU. Furthermore, the early programming experiences can scaffold on students early expectations for physical cause-and-effect, direct control of memory through a program. Finally, the third principle is addressed through several aspects. In teaching students the basic process of creating and debugging computer programs, the meta-cognitive processes involved in solving open-ended problems should be demonstrated and reinforced. The programming target hardware provides students the tools and roadmap to direct learning beyond the classroom. The repetition of programming applications throughout the course and follow-on curriculum moves toward advanced, open-ended problems ending with the capstone design that will encourage computer integration in design.

This principle indicates that learning requires engagement. Therefore, measures for engagement and attitude are employed in evaluating the effectiveness of the model. Measuring of attitude toward different engineering disciplines has received attention in literatures [13-17]. These literatures eludes that in general, attitude is measured by assessing students' perceptions of the engineering professions and of their preparation of study the field. The students' perceptions are measured through surveys, often times using pre and post course surveys. Generally the questions in the surveys are in form of statements which express a view point and attitude towards the discipline. The students are asked to give their level of agreement or disagreement on each statement using some form of Likert[17] scale. Most of these surveys use five point Likert scale with higher values indicating greater levels of agreement with the statements. The scale is designated as 5- strongly agree, 4 - moderately agree, 3- no opinion, 2 -moderately disagree, and 1- strongly disagree.

### **3. COURSE DESCRIPTION**

The course is design as a traditional "Introduction to Programming for Engineers" course in a two, three or four hour arrangement with a lab opportunity. The course follows a traditional syllabus and lecture series. The programming examples labs and assignments however are developed for a microcontroller (MCU) based target. The MCU programming examples and assignments provide a context-appropriate demonstration of engineering practice. Transparency in the programming applications can be achieved through programming the MCU in C that gave direct control of memory and I/O registers, making it a good fit for electrical or computer engineering students. When the programming platform is Matlab, a greater level of abstraction for the input/output registers is easily achieved through simple functions, while allowing the

students to directly control input and output devices. For the C programming approach, a commercial integrated development environment (IDE) [17] serves as the program editor and cross compiler to interfaces with the MCU. For the Matlab programming, students write their program in the usual fashion as a script in an m-file, and then cross-compile and load the program using a single Matlab command at the command line. The cross compiling routine as well as MCU-specific functions are contained in a MCU toolbox for matlab.

### 3.1 Course Content:

The course content was based on the pre-existing syllabi, with the primary topics presented in Table I.

Table I. Course Topics

Topic #	Topic
1	Introduction to programming, program design, process
2	Data types:
3	Std libraries, math libraries, math operations, text operations
4	Std libraries, math libraries, math operations, text operations
5	Conditional statements: if, else, else if
6	Repetition: while, for
7	User defined functions
8	Multi-dimensional arrays

### 3.2 Course Hardware:

A primary distinguishing feature of this work is to implement a microcontroller rather than traditional PC as the initial programming target. Further, the authors contend that the MCU selected should be appropriate for engineering practice, and at the same time be readily accessible interface through on an evaluation board. One such product is the Dragon12 plus board [18] which is based on the Motorola HCS12 MCU and was implemented in this project. This MCU is widely used in engineered products, and the Dragon12 evaluation board, shown in fig. 1 below, has numerous input / output functions integrated directly with the HCS12 MCU. Table II provides a summary of the primary features of the Dragon12 evaluation board.

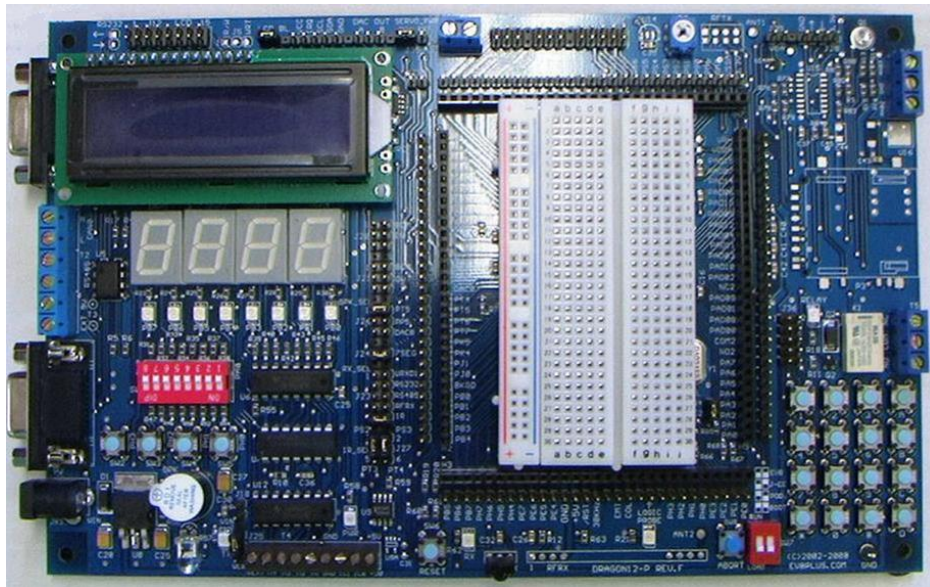


Fig. 1. Dragon 12 Plus MCU board

Table II. Summary of MHCS12/Dragon12 features

Product	Capability
Processor: MC9S12	16bit CPU, 24Mhz 256K Flash EEPROM, 12K RAM Serial communication, 10-bit ATD, timer channels, PWM, discrete I/O, interrupt I/O
Evaluation Board: Dragon12, <a href="http://www.wytec.com">www.wytec.com</a>	Output Devices: 2x16 digit LCD, single-row LEDs, 4 – 7 segment LEDs, Piezo speaker
	<b>Input Devices:</b> 8 dip switches, 4 momentary switches, 16-key keypad, IR proximity sensor, Photoresister
	<b>Other:</b> Motor driver (H-bridge)

### 3.2 Course Assignments:

Course assignments were provided weekly (over a 14 week semester) and consisted of selected problems from the course textbook, and nine programming assignments uniformly distributed over the semester. Table III summarizes the topics of these programming assignments and links them to the desired programming skills. Each programming activity was assigned with a problem statement and a required set of deliverables tied to the program performance. The assignment provided some additional support through simple examples of useful functions or a brief discussion of any physical interface issues involved. To fully complete each assignment, the student was required to implement their programmed device in a

setting outside of the classroom or lab, and provide a short, written assessment of how their observations of this experience.

Table III. Summary of Lab exercises and Project

#	Programming Skill	Description	hands-on activity
1	Introduction to programming environment, creating, compiling, building, executing	Create a simple teleprompter	display characters on a 2-line 16 char. LCD screen
2	Define/use data types	Display a running pattern of lights on leds	read digital inputs / define digital outputs
3	Use of standard library functions, math operations	Create a simple song using a piezo-speaker	Drive a speaker with a square wave of specific frequency, duration
4	Conditional statements: if, else, else if	Create a two-player game to test reaction speeds	coordinate digital inputs, display outputs based on inputs
5	Repetition: while, for	Students create a stopwatch using the speaker, LCD or 7-segment LEDs, and the push button switches.	coordinate digital inputs, display outputs based on inputs
6	Combining conditional statements, repetition	Create a device that monitors how long a refrigerator door is open and sets of an alarm if it is open for a defined length of time.	Read analog input (from a function), use this data to coordinate output functions
7	one-dimensional arrays	Create a system that requires a security code before operating a motor/light	Read digital inputs and compare to a lock-code sequence, when correct, operate a motor/light
8	Multi-dimensional arrays	Create an electronic address book that lets a user input and store a name using the push button switches, LCD and an array.	Use digital inputs to enter data into the system, recall and display this data on the LCD
9	User defined functions	Create a system that demonstrates basic elements of a servo motor system	Drive motors at different speeds using a pwm function based on analog input

#### 4. STUDENT ATTITUDE SURVEY

The programming course was implemented at Tennessee Technological University in fall 2008, spring 2009, and spring 2011. The fall 2008 and spring 09 offering was in C and spring 2011 offering was in Matlab. An assessment plan was developed to measure the impact of the model on students' attitude towards programming. The attitude evaluation was done through pre and post survey. These survey was given to both the model group (those students taking the new hardware based programming class) and the control group (students taking the traditional non hardware based programming class). After spring 2009 implementation, the questionnaire was modified based on several existing validated survey [13-16]. Table IV shows the questions in the survey related to the attitude towards programming. Questions 1-8 are common to all implementations and question 9 through 12 is added to spring 11 implantation. The students answer the questions on a 1-5 (1 – strongly disagree, 5 – strongly agree) Likert scale. Figure 2 shows the result of the pre and post course survey from Fall 08 semester. Figure 3 shows the difference between pre and post survey. Similarly figure 4 and 5 shows results from Spring 09 and Figure 6 and 7 shows results from Spring 11 semester.

Table IV. Attitude Survey Questions

1	I am sure that I can learn programming
2	Generally I feel secure about attempting programming problems
3	If I could avoid programming to get an engineering degree, I would
4	I have a lot of self-confidence when it comes to programming
5	I will use programming in many ways throughout my life
6	I am sure that I can help others use programming to solve problems
7	To be interesting to me programming needs to be connected to real world problems or applications
8	I am excited to learn programming skills that will allow me to control real world devices
9	I see myself joining a professional society related to computer programming or applications (for example ACM, Association for computer machinery) in the future
10	I am interested in joining a club that makes use of programming (for example the robotics club, Unix user group) in the future
11	I would write a program outside of the required class work
12	I would write a program to solve an assignment in another class, even if it was not required.

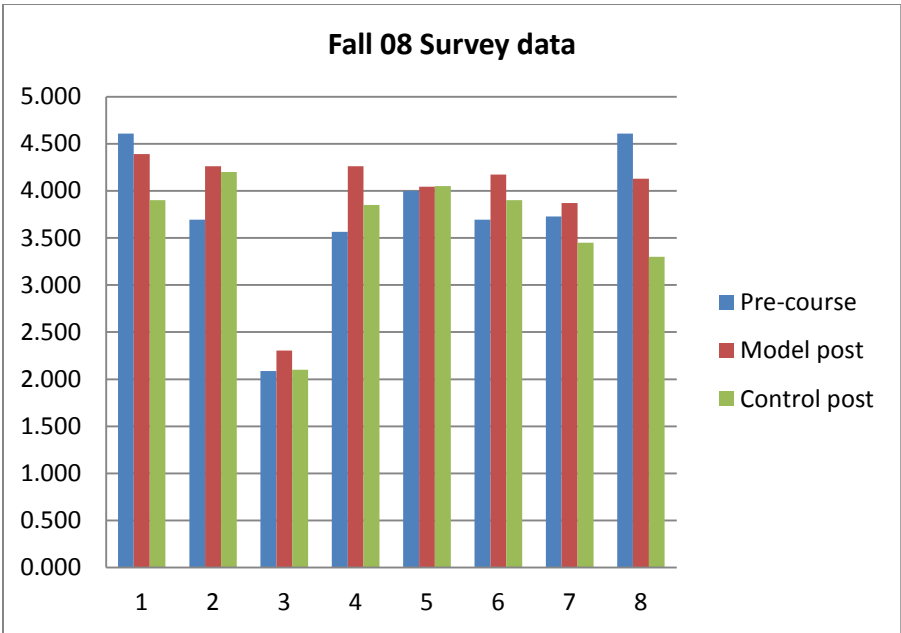


Figure 2

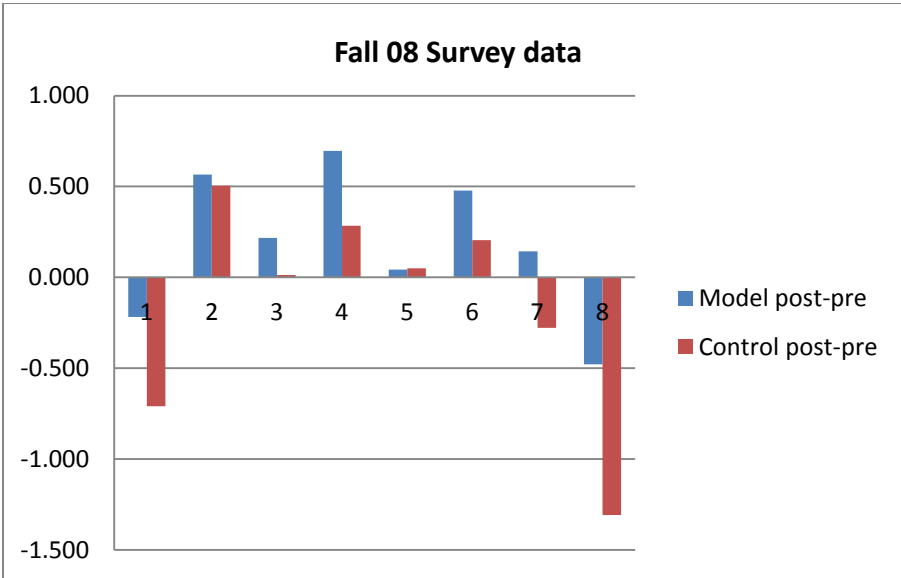


Figure 3

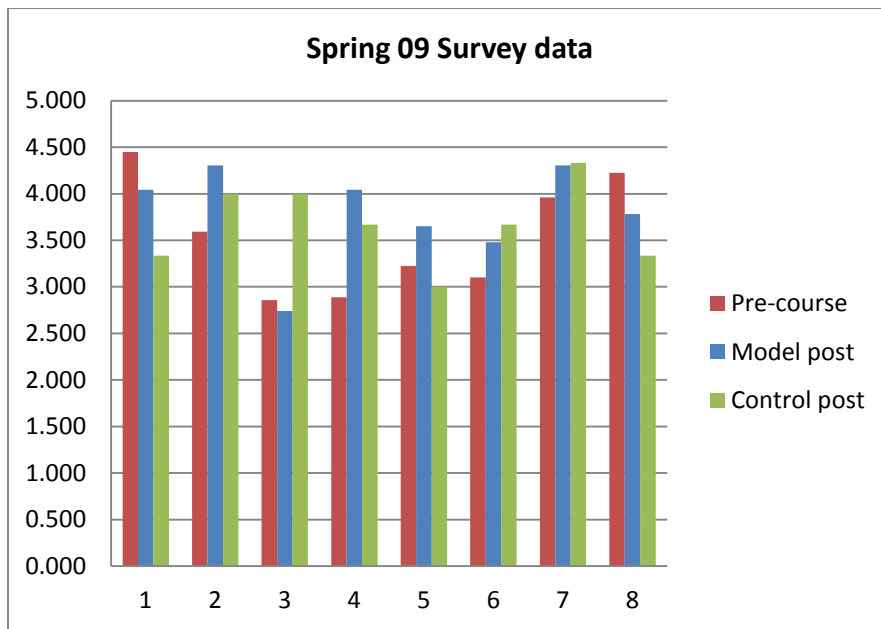


Figure 4

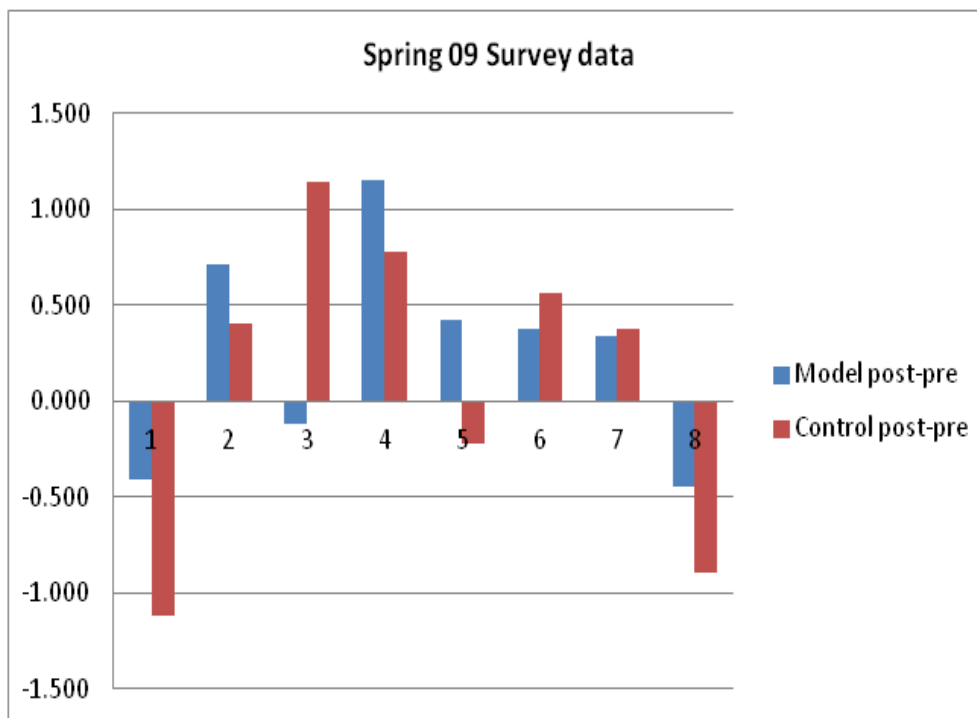


Figure 5

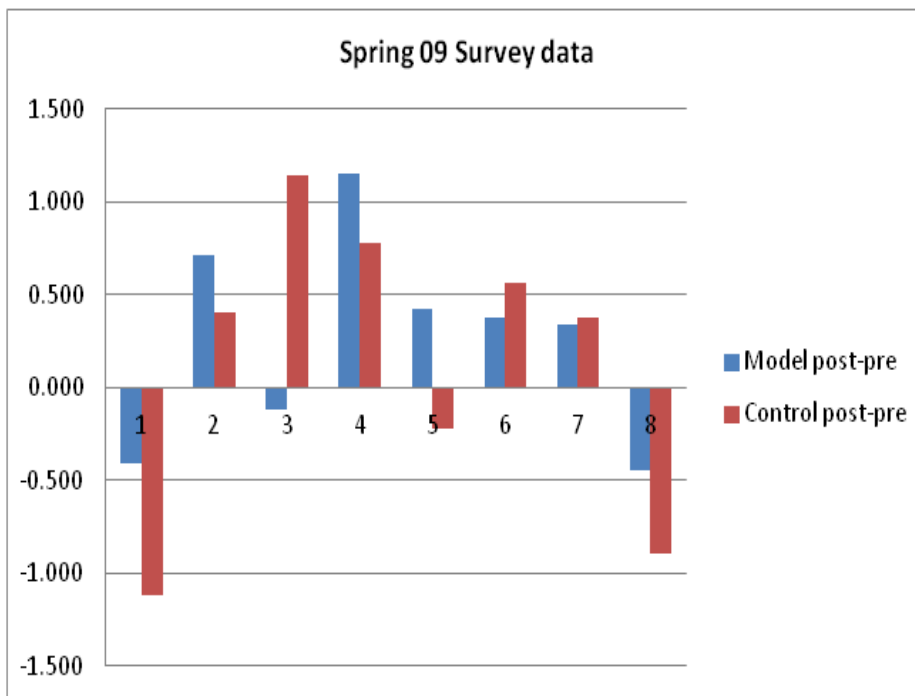


Figure 6

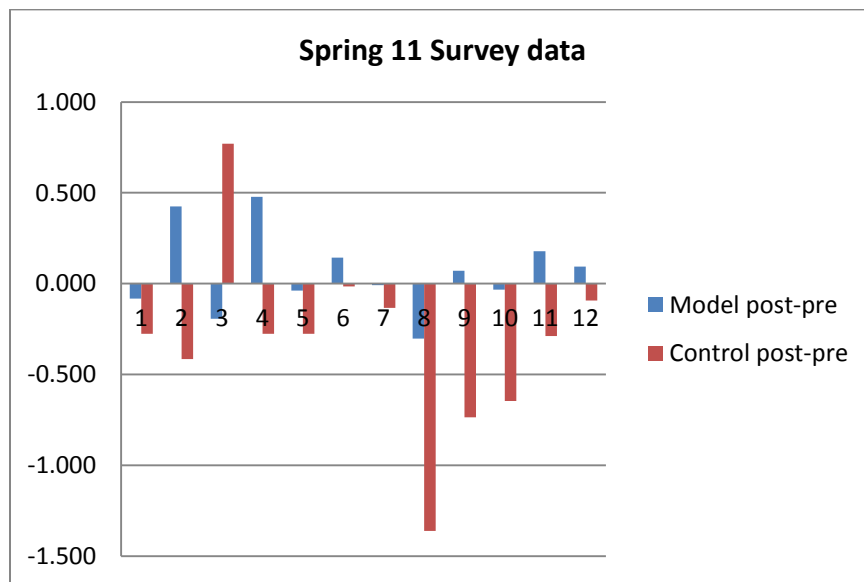


Figure 7

These results show several trends common in freshmen engineering students. They generally feel confident about their ability to learn programming, and believe it is an important skill in engineering. If we compare the attitude of the students at the beginning of the course and at the end of the course in most cases their attitude changes positively (Q2 – Q7: all semesters, Q9 – Q12 spring 11) for the both model group and the control group. In case of model group the change is more positive than the control group. In few cases (Q1 and Q8) it can be seen that the students' attitude has been changed negatively. However, the change in model group is less negative than the change in control group. One potential reason for the negative change in attitude is the difference between students' perception about programming before entering the



course and the reality they face during the course. Many freshman students entering in the programming course have the perception that if they successfully complete the course they will be able to develop video games or applications like face book etc. During the course they see that programming requires hard work, study, and lot of hands on practice. They realize developing any significant computer program would require further study, in programming, math, and lot more practice. As a result their initial attitude and excitement about programming decreases. However, the overall change in students' attitude towards programming is positive. The results indicate in general, students that engaged in the hands-on, hardware-based programming activities feel more confident in their ability to learn and use advanced programming and they have more positive attitude towards programming.

## 5. CONCLUSIONS

This paper has presented a model for the restructuring of the traditional "Introduction to Programming" course for engineering students with an emphasis on hands-on application of programming assignments. The underlying pedagogical foundations of this activity are to engage incoming students' notions of engineering and to build on this early knowledge in a progressive fashion with real-world programming applications that are relevant to engineering and appropriately selected for the target group. The redesigned programming course was implemented at TTU. Students that engaged in the hands-on, hardware-based programming activities reported a more positive change in their attitude towards programming relative to their comparison-group peers. In some cases negative change in attitude has been observed in both groups of students. However, the change is less in case of model group. The negative change in student's attitude can be attributed to difference between students' perception about programming before the course and the reality they learned during the course.

## REFERENCES

- [1] Shallcross, Lynne, "Piecing It All Together", ASEE Prism, November 2006, Volume 16, Number 3, [http://www.prism-magazine.org/nov06/tt\\_01.cfm](http://www.prism-magazine.org/nov06/tt_01.cfm).
- [2] Canfield, S. L., and M. A. Abdelrahman, "Enhancing the Programming Experience for Engineering Students through Hands-On Integrated Computer Experiences," *Proceedings of 2009 ASEE Southeastern Section Annual Conference*, Marietta, GA, Apr. 5-7, 2009.
- [3] Herniter, M. E., Scott, D. R., and R Pangasa, "Teaching programming skills with MATLAB", 2001 ASEE Annual Conference and Exposition, Jun 24-27, Albuquerque, NM.
- [4] Clough, D. E., Chapra, S. C. and G. S. Huvard, "A Change in Approach to Engineering Computing for Freshmen, - Similar Directions at Three Dissimilar Institutions," 2001 ASEE Annual Conference and Exposition, Jun 24-27, Albuquerque, NM.
- [5] M. H. Naraghi and B. Litkouhi, "An effective approach for teaching computer programming to freshman engineering students," 2001 ASEE Annual Conference and Exposition, Jun 24-27, Albuquerque, NM.
- [6] Adamchik, V. and A. Gunawardena, "Adaptive book: Teaching and learning environment for programming education", *Proceedings ITCC 2005 – International Conference on Information Technology: Coding and Computing*, Las Vegas, NV, Apr. 4-6 2005, p 488-492.
- [7] Calloni, B. A. and D. J. Bagert, "Iconic programming for teaching the first year programming sequence," *Proceedings – Frontiers in Education Conference*, v 1, Atlanta, GA, Nov. 1-4 1995, p 99-102.
- [8] Colombo, M. A., M. R. Hernandez and J. E. Gatica, "Combining high-level programming languages and spreadsheets an alternative route for teaching process synthesis and design," 2000 ASEE Annual Conference and Exposition, St. Louis, MO, June 18-21, 2000, p 773-784.

- [9] W. Campbell, "Teaching programming by immersion reading and writing," Proceedings – Frontiers in Education Conference v1, Boston MA, Nov 6-9 2002, p T4G/23-T4G/28.
- [10] K. Scott, "Teaching Graphical Interface Programmin in Java with the Game of Wari," Proceedings for the 8th Annual SIGCSE Conference on Innovation and Technology in Computer Science Education, Tessaloniki, Greece, Jun 30-Jul 2, 2003, p 254.
- [11] Bransford, J. D., Brown, A., & Cocking, R., How People Learn: Mind, Brain, Experience and School, Expanded Edition, Washington, DC: National Academy Press, 2000.
- [12] Committee on How People Learn, A Targeted Report for Teachers, How Students Learn: History, Mathematics, and Science in the Classroom, M. Suzanne Donovan and John D. Bransford, *Editors*, THE NATIONAL ACADEMIES PRESS Washington, D.C., 2005.
- [13] Annalisa Weigel, Survey of Aerospace Student Attitudes. <http://web.mit.edu/caspar/aerosurvey.htm>
- [14] Jean-Claude Thomassian, Anoop Desai, and Patrick Kinnicut, " A Study of Student Attitude towards Media Based Instruction in Introductory Engineering Courses", Proceedings of the 38th ASEE/IEEE Frontiers in Education Conference, October 22 – 25, 2008, Saratoga Springs, NY
- [15] Nocito-Gobel, J. M. Collura, S. Daniels, and I. Orabi, "Are Attitudes Toward Engineering Influenced by a Project- Based Introductory Course?", Proceedings, 2005 American Society for Engineering Education Annual Conference and Exposition, Portland, Oregon, June 12 - 15, 2005.
- [16] Besterfield-Sacre, M.E., C.J. Atman, and L.J. Schuman, "Engineering Student Attitudes Assessment", *Journal of Engineering Education*, 87(2), April 1998, pp. 133-141.
- [17] Rensis Likert, A Technique for the Measurement of Attitudes, " Archives of Psychology, No.140, 1932.
- [18] Dragon12 plus, [www.evbplus.com](http://www.evbplus.com)
- [19] Freescale Codewarrior, [www.freescale.com](http://www.freescale.com)

**Elements of Visual Literacy and Presentation  
Design from First Year Student Projects**

Suzanne Keilson  
SKeilson@loyola.edu

## **Elements of Visual Literacy and Presentation Design from First Year Student Projects**

### **ABSTRACT**

A problem solving project has been given to first year students in an introduction to engineering class over a number of years. The students present their work including their process and method and proposed solutions at the end of the semester. These projects can vary from improved laundry or eating facilities to improved lighting on cars. The focus is on the problem solving process. Typically students create presentations in software (Powerpoint). Working in collaboration with a visual arts faculty member in the department of Fine Arts a review of first year problem solving design presentations was conducted. A side by side comparison of the original and revised presentations led to some conclusions about best practices and elements of visual presentation design to teach to engineering students. This was presented to a subsequent year's class of students to improve their presentations. An evaluation rubric is being developed for this year's class as a baseline for refining the education of students in visual literacy. This is a crucial but often neglected element for every student, but especially in an engineer's education.

### **INTRODUCTION**

A version of a first year introduction to engineering course is offered that is open to all students of all majors. About 1/3 of the students continue in Engineering, 1/3 in business majors and 1/3 in other science, humanities or social science majors. The course may as part of the general education core curriculum for students. The learning aims of the course include having students be able to distinguish what makes engineering different from science and what are the elements of an engineering problem solving or design process. Most students learn of the scientific method but far fewer learn anything explicit about an engineering or problem solving methodology. This methodology is found in a wide variety of professional disciplines including project management, computer science, software engineering, product development, creativity, innovation and areas of business administration. The names and numbers of the steps may vary, but the point is to introduce the students to the essentials of (1) problem definition, (2) identify users, stakeholders and their needs, (3) brainstorm solutions and creativity, (4) evaluation possible solutions, (5) prototype solutions, (6) evaluation and iteration of the design process.

The culminating project for students in this class is described as just such a problem solving project where students take familiar problems that they encounter in their transition to residential living on a college campus and walk through some of these steps, without an prototype and build elements. They present a powerpoint presentation and a brief paper on the last day of class. Over the years the question of what constitutes appropriate expectations for such a presentation began to grow in this instructor's mind. There are rubrics available (REF) to evaluate presentations, but still it felt like something was missing. A more in depth knowledge of the mechanics of what went into an outstanding vs. a good or fair presentation seemed to be missing. In partnering with a faculty member from the Fine Arts department the language of visual analysis were brought to bear on these presentations.

Students were presented with two side-by-side powerpoint presentations to compare elements of composition, line, font, message, and images. One class was devoted to a guest lesson by the fine arts faculty member on fundamental elements of “visual literacy” which included what to look for in terms of visual consistency and where and how to store, find, and maintain libraries of digital images. Simple techniques such as creating borders around images and understanding pixel size, density, and image aspect ratio helped to improve student presentations. The design of presentations and effective communication and its associated mechanics are fundamental skills for all educated people in the 21<sup>st</sup> century, just as the mechanics of writing different forms such as a memo or an internal report are an expected part and parcel of a professional engineers toolkit. Edward Tufte prominently among others has pointed out that effective graphical and technical communication can make the difference between life and death in some situations such as the two shuttle disasters. Working with a colleague from the Fine Arts field provided the language and vocabulary in which to address and understand this need and skill more deeply. Some example powerpoint images from the tutorial should illustrate the points well.

**Engineering and Non-Engineering Aspects of Environmentally Sustainable  
Infrastructure**

ASHRAF GHALY, Ph.D., P.E.  
Professor of Engineering, Union College  
Schenectady, NY 12308  
ghalya@union.edu

# **Engineering and Non-Engineering Aspects of Environmentally Sustainable Infrastructure**

## **Abstract**

Sustainable infrastructure entails many engineering and non-engineering aspects. The engineering features comprise design, construction, and operation. The non-engineering features involve economics, politics, and culture/public acceptance. Sustainability as a concept is almost universally accepted by all but the ways and means to achieve it and to cover its cost are often sources of passionate debate. One of the aspects that are hard to quantify monetarily is the return on investment in sustainable versus conventional facilities. However, more people everyday recognize the strong relationship between the performance of infrastructure facilities and a sustainable environment. A sustainable environment cannot be realized by the effort of only a few. It requires the collective effort of all because every contribution adds up toward the goal of sustainability. A course has been developed to teach the basic principles of sustainability to mainly non-engineering students with background in policy development, economics, and social and natural sciences. Infrastructure is used to communicate the message of sustainability because it is a daily encounter and the members of the public can easily relate to many of its components such as roads, bridges, clean water, waste water, ports, railways, waterways, transit, aviation, energy, communication and digital networks, etc. The main goal was to illustrate the many intertwined factors that must be reconciled to attain the goal of sustainability, and that this goal can only be achieved by team effort. The course focused on preservation and conservation of materials, better and environmentally-friendly features in designed facilities, better management and operation practices, efficient repair, and low impact decommissioning techniques. The course was also greatly concerned with policies related to infrastructure financing and new models of public-private partnership, or design-build-manage operation for a certain concession period. Students in general, and non-engineering students in particular, appreciated the multidimensional nature of the issues related to sustainability as it became clear that these are multifaceted problems that require a holistic approach in addressing them.

## **Introduction**

Infrastructure is the society's inventory of facilities that require long term planning, construction, management, operation, maintenance, and upgrading. These are facilities used by members of the public on a daily basis. The extent to which infrastructure impact a person's daily life cannot be overstated. Infrastructure comprises vital facilities that a society cannot function without such as roads, bridges, dams, levees, communications networks, energy generating plants, power distribution grids, transportation and traffic-related structures, ports, navigation locks, airports, railroads, waste disposal, wastewater treatment, purification of drinking water, parks, etc. The public's dependence on infrastructure goes usually unnoticed until a problem occurs. Problems could arise due to aging of existing infrastructure, lack of timely maintenance, overuse, failure to upgrade deteriorating components, or natural disasters such as earthquakes, hurricanes, tornadoes, or floods. In the initial stages of planning a new infrastructure project, many engineering and non-engineering factors must be taken into consideration. Engineering factors are the responsibility of the design engineer and are tightly controlled by relevant engineering codes. Non-engineering factors are numerous and are often open for debate from concerned constituencies. Politics, economics, and social concerns are the major non-engineering factors

that receive the greatest attention. In absence of a clear vision for a new infrastructure project, debates concerning the scope and features of design can drag on for a lengthy period of time. In light of a tight money supply, coupled with a desire to preserve the environment, the need to address the issue of sustainability is greatly emphasized in new facilities. Sustainability features can have an impact on a structure before construction, during operation over the life of the facility, and through upgrading, replacement, or decommissioning.

The American Society of Civil Engineers (ASCE) is immensely concerned about America's infrastructure. It attempts to raise the profile of this issue by investing time and money in gathering information about the nation's infrastructure, compiling it, issuing a report card detailing the health of America's infrastructure facilities. ASCE issued in 2009 its latest report card in which individual grades were given to various infrastructure facilities and a cumulative grade was given based on these individual grades. The cumulative grade ASCE assigned was a "D". Furthermore, it was estimated that 2.2 trillion dollars of expenditure was required to maintain America's infrastructure facilities. It is worth noting that many of America's infrastructure facilities have been constructed decades ago, and significant percentage of these facilities have reached or surpassed their intended design life. Most of the evaluated facilities received grades ranging from the equivalent to poor to mediocre condition. Under such circumstances, these facilities needed decommissioning, upgrading, or replacement.

Due to the shortage of funds necessary to meet all needs, and the significant political difficulties in appropriating the money needed for various projects, ASCE viewed sustainability as a critical element of civil engineering infrastructure. Lately, ASCE has been developing a sustainability rating system. It is intended to address the widening gap between actual infrastructure needs and available funds to tackle these needs. ASCE has embarked on a mission to educate civil engineers about the new Sustainable Infrastructure Project Rating System spearheaded by the ASCE Committee on Sustainability. Partners in this effort are American Council of Engineering Companies (ACEC) and American Public Works Association (APWA). It is also anticipated that the Federal Highway Administration (FHWA) and the U.S. Army Corps of Engineers will play a pivotal role in refining current efforts into a comprehensive rating system to address wider sustainability goals.

In its roadmap for the civil engineering profession, ASCE defines civil engineers as individuals *entrusted by society to create a sustainable world and enhance the global quality of life*<sup>1</sup>. Also, in its Vision 2025 for the profession, ASCE stipulates that *civil engineers serve competently, collaboratively, and ethically as master:*

- *Planners, designers, constructors, and operators of society's economic and social engine—the built environment;*
- *Stewards of the natural environment and its resources;*
- *Innovators and integrators of ideas and technology across the public, private, and academic sectors;*
- *Managers of risk and uncertainty caused by natural events, accidents, and other threats;*  
*and*
- *Leaders in discussions and decisions shaping public environmental and infrastructure policy.*

It can be seen that ASCE places great importance on sustainability as a pivotal issue in planning, design, construction, and operation. Future engineers have the added responsibility of leading



discussions concerning new infrastructure facilities and educating the public to realize the prominence of sustainability as an integral factor in tomorrow's designs. Failure to shape the public's opinion on environmental and infrastructure policy matters can lead to unwanted setbacks.

### **Urbanization, infrastructure, and sustainability**

According to United Nations' statistics, the rate of urbanization is currently about 1.3 million new city dwellers a week, which translates to 70 million a year<sup>2</sup>. The world was 3% urban in 1800, 14% urban in 1900, 50% urban in 2007, and probably headed in the next few decades to around 80% urban, which has been the stabilization point for developed countries since the mid-20th-century<sup>2</sup>. The concentration of population in smaller areas of land has many adverse effects. Congestion of population results in greater demand for services and natural resources such as food, energy, and water. Moreover, the construction of houses, roads, and other facilities replaces the natural cover of the soil with solid surfaces, such as asphalt and concrete, which alters the pattern of climate and creates the phenomena known as the heat island effect. This effect raises temperatures and elevates the demand for energy used for cooling. Solid surfaces also exacerbate the problem of contamination as storm water carries oil and grease swept from streets and parking lots.

Design of infrastructure systems is closely related to the density of population they serve. With heavier concentration of population, vertical expansion of facilities becomes unavoidable. Expanding skyward comes at an enormous cost to upkeep and to maintain various systems. Expanding downward also costs enormous capital to maintain and operate underground facilities. Rotating design philosophy is a concept in designing systems where lightly loaded components in a network help those that are heavily loaded. Theoretically, at least, this helps the system maintain equilibrium by preventing the failure of overloaded elements. Management of such vast systems is always a colossal challenge.

### **Infrastructure challenges**

The National Research Council<sup>3</sup> issued a list of recommendations concerning the challenges of moving toward critical infrastructure systems that are physically, economically, socially, and environmentally sustainable. These are:

Challenge 1. Ensure that critical infrastructure systems effectively support competitiveness in the global economy.

Challenge 2. Develop the critical infrastructure systems that support responsible energy independence.

Challenge 3. Upgrade, renew, replace, and provide new infrastructure systems to meet current and future requirements; improve reliability; improve performance and cost-effectiveness; promote equitably public safety, health, welfare, and social equity; and protect the environment.

Challenge 4. Optimize public- and private-sector investments in critical infrastructure systems and ensure adequate, long-term revenue streams for their operation, maintenance, and repair.

Challenge 5. Improve the reliability and resiliency of critical infrastructure systems to reduce the adverse impacts of human-made and natural disasters.

Challenge 6. Create a base of long-term support among users for infrastructure investments.

Challenge 7. Support innovation through the development and adoption of new approaches, technologies, and materials that have the potential to improve the delivery, quality, reliability, and sustainability of critical infrastructure services.

Challenge 8. Enhance international exchange and coordination of critical infrastructure systems approaches, services, components, and materials—with respect to finance, public and private ownership structures, regulations, and other factors.

## **Policy trends**

Recent trends in financing, maintaining, and managing infrastructure facilities show a shift toward public and private partnership. Some of these policies include: coordination and cost-sharing cooperation, management contracting, leasing and concessions, and privatization. In terms of financing infrastructure investment, some of the recent models include: shift costs to user and beneficiary groups (user fee), impose consumption fee, flexible pricing (shift demand for infrastructure services to off-peak hours or congestion fee to reduce emission and pollution), and pay-as-you-go (phase development).

Whether infrastructure facilities are being run by public or private entities, state governments are usually responsible for: setting the policy framework for infrastructure, facilitating local government, private sector, or nonprofit provision of infrastructure, regulating providers of infrastructure services to ensure that standards of quality and service are being met, providing oversight to ensure fair prices and tariffs, and guaranteeing that low-income households, rural residents, and rural businesses have adequate access to infrastructure services.

In discussing new infrastructure projects, public participation is vital especially if a project can only be realized by imposing new taxes or by passing new bonds. In democracies where freedom of speech is guaranteed, every one is entitled to his/her opinion. This can result in significant delays in urgently needed projects. Finding a common ground is the only way forward, but making concessions may not be that easy. Balancing the competing financial, environmental, engineering, safety, and other interests may not result in the best outcome for any individual factor. The goal should always be to optimize the outcome rather than to realize the best outcome for only one factor.

## **Politics, economics, and society**

Infrastructure and politics: Infrastructure funding and decisions related to facilities are infested with politics, deal making, lobbying, mutual favors, etc. Appropriations for upgrading existing infrastructure or those for new facilities go through layers of bureaucracy that are usually influenced by politics. Infrastructure projects are sometimes used as a bargaining chip, or as a pressure tool, to pass certain laws with other provisions (or earmarking) that may not be entirely acceptable to voting politicians. Infrastructure projects may also be used as a means to get federal or state aid or to raise taxes. The state of infrastructure may be used by politicians to gain favor with voters or to expose deficiencies in opponents during election seasons.

Infrastructure and the economy: The state of infrastructure has a profound impact on economic activities. Societies need infrastructure to survive and thrive. Undertaking of infrastructure projects spurs economic activities. Large infrastructure projects provide employment to a wide segment of population, which reduces the burden of unemployment. The cycle of economic

growth assumes (and expects) that infrastructure will require upgrading and replacement at certain time intervals. Societies maintaining their infrastructure in good shape are almost guaranteed superior economic growth. The considerable rate of return on infrastructure projects makes a strong case for more expenditure. Capital infrastructure projects help spark private investment in land development. All of the above activities are mainly good for the economy because they contribute to widening the tax base but side effects are also possible, such as high population density, pollution, contamination, congestion, high cost of living, etc.

Infrastructure and social behavior: Infrastructure greatly reflects on social behavior. Examples related to behavior on the road include drivers staying in lanes versus chaotic traffic; drivers courteous to pedestrians versus disregard to foot traffic; waiting in line versus aggressively cutting through it; interaction with other people using gentle language versus offending vocabulary or aggressive hand gesture; etc. Social behavior reflects on the society as a whole. People with smoothly functioning infrastructure facilities are more relaxed and less stressed. This reduces friction, conflict, and crime in the community (road rage, for example).

### **Public views and culture**

The worth of infrastructure could be determined based on the monetary value of a physical structure (e.g., a bridge, road, water treatment plant), a valuable commodity (e.g., time), or a means of enjoyment and satisfaction (e.g., convenience). To calculate the worth of an infrastructure facility, one needs to price time and convenience. This is oftentimes difficult and controversial, but not impossible if done with objectivity. Societies that prize time and convenience are willing to pay high premiums for such items. The worth of the physical facility may decline or depreciate over time but the worth of time and convenience is likely to remain the same or even increase. The worth of infrastructure is a complex subject with many parameters and varying viewpoints. The fact that remains unchanged, and unchallenged, is that: infrastructure worth divided by the number of individuals benefitting from the facilities equals extra income and improvement in life quality. The greater the worth the higher the value gained by every member in the community.

Another important factor that must be realized in designing sustainable facilities is eventuality of infrastructure change. Human ingenuity will continue to find new ways to improve existing infrastructure facilities. The motives for better service, economical facilities, and lower cost will always drive humanity for change. Change is eventual but if it does not happen in a timely and organized fashion, market forces take charge and force it. The public's culture may embrace or abandon change. Embracing change is a sign of moving in a new, and more often than not, better direction. Abandoning change is a sign of lack of public interest or absence of enthusiasm to cause or implement change. Whatever the reason for change is, it is meant to be for a better outcome, and should always lead to more prosperity. Change that slows or hinders progress is dead on arrival. Evolution-centered change due to policy, public pressure, the environment, etc. is a natural outcome of society development. Communities are in constant pursuit of new ways to advance their goals. Resisting change due to fear of change is groundless and must be rejected.

### **Scope of sustainable design**

There has been a considerable shift in the way infrastructure facilities are being designed. This paradigm of the "new economy" places a significant emphasis on sustainable design, which

allows constructed facilities to be more environmentally friendly, easier to manage, and have longer life. Some of the methods toward achieving these goals include:

- Less energy consumption
- Less material use
- Emphasis on reuse and recycling
- Focus on environmental and climatic impact
- Smart and efficient infrastructure
- Monitoring and sensor technology
- Assessment of performance
- Public awareness and education

The degree of impact of each of the above factors on the design of sustainable facilities varies depending on the type of the facility under development. It must also be recognized that many infrastructure facilities serve in an open environment where they are constantly subjected to the elements. Under such circumstances, design provisions must cope with nature rather than resisting it. Furthermore, it should be emphasized that patterns of climate change or rising water levels be incorporated in project design to assure sustainability for the longest possible period of time.

There are also new realities that require different design and management techniques. This includes: the danger of depletion of resources, the emphasis on recycling and sustainability, the aging of population in developed countries, the high percentage of youth in developing countries, and the aging of infrastructure that reached the end of its design life. In addition to traditional natural sources of hazard such as earthquakes, tornados, hurricanes, and floods new unconventional threats to infrastructure include man-created explosions and other destructive acts. These are all factors that require higher levels of security and greater provisions for safety. They also demonstrate the need for an unorthodox approach for design and management. One cannot ignore the fact that the world is no longer defined by the boundaries between its countries. The fast and easy communication and transportation methods made Planet Earth like a global village. This sphere is where humanity existed from the beginning of history, and where it continues to exist today. Humans are faced with some extraordinary challenges that must be addressed immediately in the design, construction, and management of infrastructure facilities. These challenges call for the use of new, smarter, and efficient materials, the adoption of new methods and processes in manufacture, the implementation of new practices in operating facilities to lengthen their useful life and to reduce the cost of maintenance, and overcoming long standing inefficient management approaches that rely heavily on the human factor. Systems monitoring and management can be done today using sophisticated software and wireless devices. Improvements of methods of planning, design, construction, maintenance, and management are only possible with monitoring and assessment of facilities performance. Record keeping and well documentation of performance are greatly important in enhancing future facilities performance. This can optimize the functions of all components in a system. In addition, it can communicate information as changes happen without any time delay, which can enhance the decision making process.

### **Course development and assessment**

The issues presented in the above demonstrate the necessity for future engineers and concerned citizens to understand how sustainability must become a way of living. It is imperative for

tomorrow's decision makers to appreciate the depth and breadth of the problems that Planet Earth may face due to unsustainable pace of resource depletion. The developed course aimed at teaching the basic principles of sustainability to students from various backgrounds. Infrastructure facilities were used to illustrate the issues at stake as they are a daily encounter and the members of the public can easily relate to many of its components. Students gained insight into the many intertwined factors that must be reconciled to attain the goal of sustainability, and realized that this goal could only be achieved by team effort. It was evident that the subjects of infrastructure and sustainability enjoy sizable appeal with many segments of the student population. This natural appeal is an opportunity and a challenge at the same time. The opportunity is due to the fact that such a course can be used to shape young minds to appreciate the need for sustainable infrastructure facilities. The challenge arises from the fact that many of the non-engineering students that take such a course have limited technical background that makes it difficult to teach intricate engineering principles. Thus, it is imperative to approach the subject matter in a balanced manner that will simultaneously win the engineers and not turn off the non-engineers. This is no easy task but is achievable with proper preparation and the extensive use of real-world examples that illustrate the points being made. Official course evaluation indicated that it was well received. The course earned high marks for the teaching approach that blended technicalities with policy.

In addition to exams, class discussion, and participation, the course required each student to research and write a term paper on a subject of their choice. Each student's selected subject has to address the themes of both infrastructure and sustainability, and students were required to receive the instructor's approval of their chosen subjects one month prior to the paper's due date. These papers proved to be an excellent venue for students to report on a subject that interested them. The variety of the selected topics and the depth with which these papers were written were gratifying. In addition to the written report, each student made a class presentation followed by questions and answers period. It was evident that students were totally invested in their selected topics and were excited to share their findings with the class. It should be noted that due to the dynamic nature of the subjects of sustainability and infrastructure, future course offerings will require constant updating of the materials taught.

## References

- (1) American Society of Civil Engineers (ASCE) (2009). "Achieving the Vision for Civil Engineering in 2025: A Roadmap for the Profession," ASCE, 74, pages.
- (2) United Nations (UN) (2010). "2008 Demographic Yearbook," Department of Economic and Social Affairs, United Nations, ST/ESA/STAT/SER.R/39.
- (3) National Research Council (NRC) (2009). "Toward Sustainable Critical Infrastructure Systems: Framing the Challenges Workshop Committee," National Academies Press, 82 pages.

## **A Fabrication Procedure for a CdTe Quantum Dot Printable Hybrid Solar Cell**

Kyle D. Gilroy

Department of Mechanical Engineering,  
Temple University, Philadelphia, PA 19122

Mohammad S. Islam

Department of Mechanical Engineering,  
Temple University, Philadelphia, PA 19122

Robert A. Hughes

Department of Mechanical Engineering,  
Temple University, Philadelphia, PA 19122

Svetlana Neretina

Department of Mechanical Engineering,  
Temple University, Philadelphia, PA 19122

Brandon Lee

Department of Mechanical Engineering and Mechanics,  
Drexel University, Philadelphia, PA 19104

Ying Sun

Department of Mechanical Engineering and Mechanics,  
Drexel University, Philadelphia, PA 19104

# A Fabrication Procedure for a CdTe Quantum Dot Printable Hybrid Solar Cell

*Kyle D. Gilroy, Mohammad S. Islam, Robert A. Hughes and Svetlana Neretina*  
Department of Mechanical Engineering, Temple University, Philadelphia, PA 19122

*Brandon Lee and Ying Sun*  
Department of Mechanical Engineering and Mechanics, Drexel University, Philadelphia, PA 19104

**Abstract:** Solution-based CdTe quantum dots were fabricated following the synthetic protocols devised by Bawendi and co-workers. The nanocrystals, which are spherically shaped, are derived from colloidal solutions having oleic acid and trioctylphosphine as stabilizers. The quantum dots produced exhibit a strong photoluminescence where the wavelength of the luminescence was varied by altering the extraction time from the reaction vessel. Absorbance measurements on the various aliquots exhibit maxima extending from 540 to 663 nm. Transmission electron microscopy indicates that the CdTe nanocrystals are indeed spherical where the ensemble shows a narrow size distribution. Energy dispersive x-ray spectroscopy confirmed that cadmium and tellurium are present in a 1:1 ratio. Ink formulation begins by first precipitating the CdTe nanocrystals through centrifugation to produce a fine powder, dissolving the powder in toluene, and then combining the solution produced with the photoactive organic semiconductors P3HT and PCBM. Solar cell fabrication proceeded by first applying the ink mixture to an ITO-coated glass substrate using a Dimatix Materials Printer DMP-2800. Following a high temperature anneal of the ink, the solar cell device fabrication was then completed by applying layers of Poly(3,4-ethylenedioxythiophene), poly(styrenesulfonate) (PEDOT:PSS) and a top gold electrode. The work demonstrates the viability of fabricating a printable solar cell architecture based on CdTe-based quantum dot inks.

## 1. Introduction

One of the foremost challenges facing next generation photovoltaics is to advance designs which deliver flexible, low-cost alternatives to the rigid-substrate silicon-based architectures which presently dominate the marketplace<sup>1-4</sup>. The emergence of companies such as Nanosolar<sup>5,6</sup> and Konarka<sup>7</sup>, which offer high-volume printable solar cell fabrication processes, reflect both the allure and promise of fabricating low-cost, efficient solar cells using conventional printing-press technologies. Inkjet printing offers a printing technology which is promising but has, thus far, remained untapped in terms of use in commercial photovoltaic technologies. While the inkjet process lends itself to the fabrication of organic solar cells<sup>8</sup>, the formation of hybrid cells which combine both an organic polymer and inorganic nanoparticles have proved more efficient in prototype architectures<sup>9,10</sup>. With theoretical calculations indicating that quantum dot solar cells have the potential to reach a maximum thermodynamic conversion efficiency of up to 66%<sup>11</sup>, the development of hybrid photoactive ink formulations which are compatible with inkjet printing processes presents one of the key challenges in advancing this technology. Thus far, hybrid cells have, for the most part, relied on the II-VI semiconductor cadmium-selenide (CdSe) for the inorganic component<sup>12,13</sup>, while the closely related compound cadmium-telluride (CdTe) has received little attention despite the fact that it is the foremost photovoltaic material for the thin film solar cell industry<sup>14-16</sup>. Here, we present our studies

focused on fabricating a photoactive CdTe ink formulation which is compatible with the inkjet printing process.

## 2. CdTe Quantum Dot Ink Fabrication of the Hybrid Solar Cells

Synthetic protocols for the fabrication of CdTe quantum dots were first devised by Bawendi and co-workers<sup>17</sup>. In the present study, we closely follow the methodologies of Kloper *et al.*<sup>18</sup>, but where slight variations to their procedures are made. Ink fabrication utilized polymers commonly used in organic solar cells<sup>19-21</sup>.

**2.1 Materials:** Tellurium Powder (Te, 99.997%, 300 mesh), Cadmium oxide (CdO,  $\geq 99.99\%$ ), Oleic Acid (OA, technical grade 90%), Trioctylphosphine (TOP, technical grade 90%), 1-Octadecene (ODE, technical grade 90%), Toluene (anhydrous, technical grad 99.8%), 1 Ethanol (anhydrous, technical grad 99.5%). All materials were purchased from Sigma-Aldrich.

**2.2 CdTe Synthesis:** A precursor solution, comprised of 0.1 mmol Te powder dissolved in 0.25 mL TOP, was heated to 80 °C and stirred until it turned yellow in color. Next, 2.25 mL ODE was added to the solution and gently stirred. The resulting solution was set aside while a second solution, consisting of 0.0256 g CdO dissolved in 200  $\mu$ L OA and 10 mL ODE, was prepared. This second solution was heated to 300 °C, at which point the solution changed from yellow to transparent. Further heating to 310 °C led to the precipitation of Cd nanoparticles which caused the solution to turn black. Thirty seconds after this color change, 5 mL of the Te precursor solution was injected into the flask, causing it to instantly turn red, which is a signature characteristic of CdTe nanoparticle formation. Aliquots, extracted every minute, were rapidly injected into 5 mL of ambient toluene, the effect of which was to immediately quench the reaction.

**2.3 CdTe Purification:** In order isolate the CdTe nanoparticles, a 1:3 CdTe:Ethanol solution was centrifuged at 2000 rpm for 5 min, followed by the removal of the supernatant. This procedure was repeated twice. The CdTe remaining at the bottom of the centrifuge tube was then dried under a flow of argon gas to yield a fine powder. For this purification procedure, 17 mL of solution typically yielded 100 mg of CdTe powder.

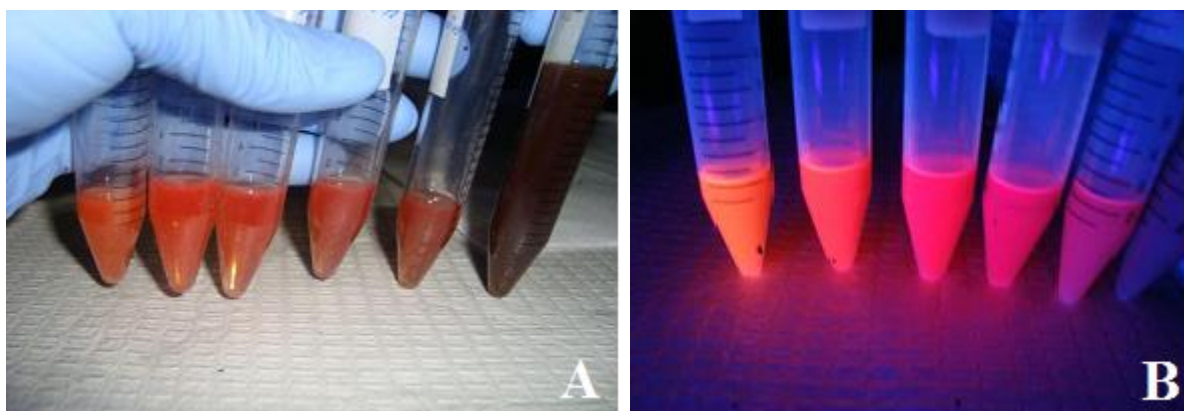
**2.4 Ink Polymer Synthesis:** Ink solutions were prepared by first adding 90 mg of the CdTe powder suspended in 0.23 mL of toluene to 0.0225g poly-3(hexylthiophene) (P3HT) and 3.7485g oDCB and then stirring the resulting ink solution for 2 hours. The ink produced has a viscosity of 1.72 cP, a surface tension of 25.51 nN/m and a density of 1.3884 g/cm<sup>3</sup>.

## 3. CdTe Quantum Dot Characterization

The CdTe quantum dots produced were characterized using photoluminescence, absorption spectroscopy (JASCO UV-VIS spectrometer), transmission electron microscopy (JEOL JEM-1400 TEM) and energy-dispersive x-ray spectroscopy (EDS).

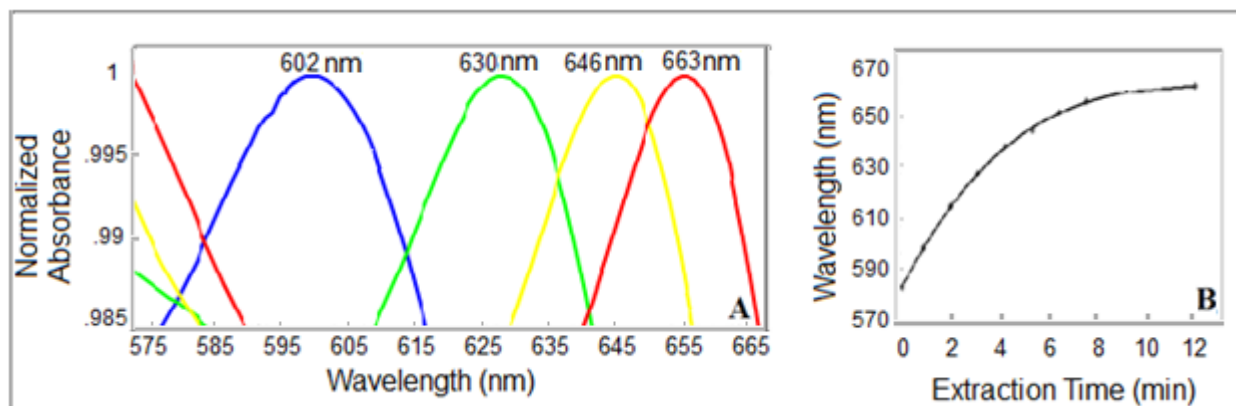
**3.1 Photoluminescence:** Figure 1 shows images of solutions containing CdTe quantum dots illuminated with visible (Fig. 1A) and ultraviolet (Fig. 1B) light. The six vials shown are aliquots removed from the reaction vessel at various time intervals. As expected, the quantum dots show the intense photoluminescence characteristic of quantum confinement.





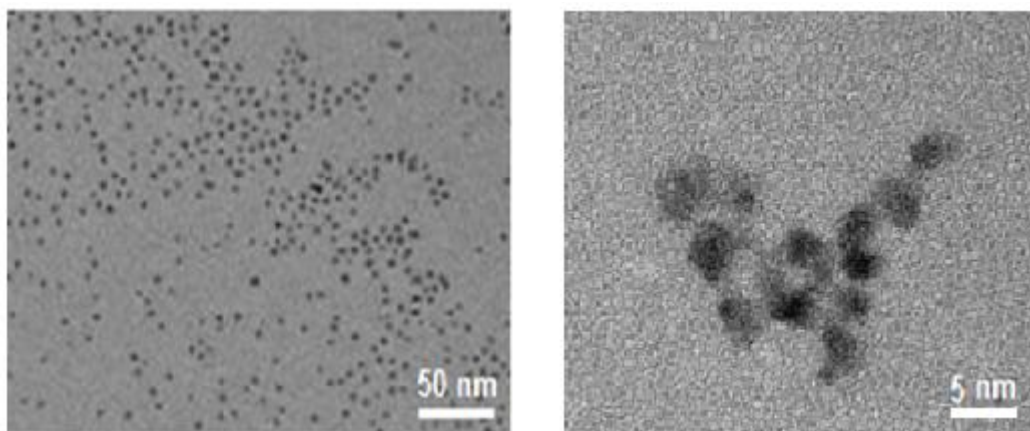
**Figure 1:** Images showing solutions containing CdTe quantum dots illuminated with (A) visible and (B) ultraviolet light. The extraction times, from left to right, are 0.5, 1, 1.5, 2, 2.5, 3 and 3.5 min, respectively.

**3.2 Absorption Spectroscopy:** Figure 2A shows the normalized absorbance spectra for the various CdTe quantum dots produced. The spectra show absorbance peaks ranging in wavelength from 550 to 700 nm where there is an increasing red-shift for the progressively larger quantum dots removed from the reaction vessel at later times. Figure 2B shows the wavelength dependence of the absorbance peak as a function of aliquot extraction time from the reaction vessel. These results are in agreement with both the quantum confinement effects expected for spherical quantum dots<sup>22</sup> as well as those observed in previous studies<sup>18</sup>.



**Figure 2:** (A) Normalized absorbance spectra for CdTe quantum dots extracted from the reaction vessel at 1, 3, 5 and 11 min which yield absorbance maxima of 602, 630, 646 and 663 nm, respectively. (B) The absorbance maxima of the quantum dots versus the extraction time from the reaction vessel.

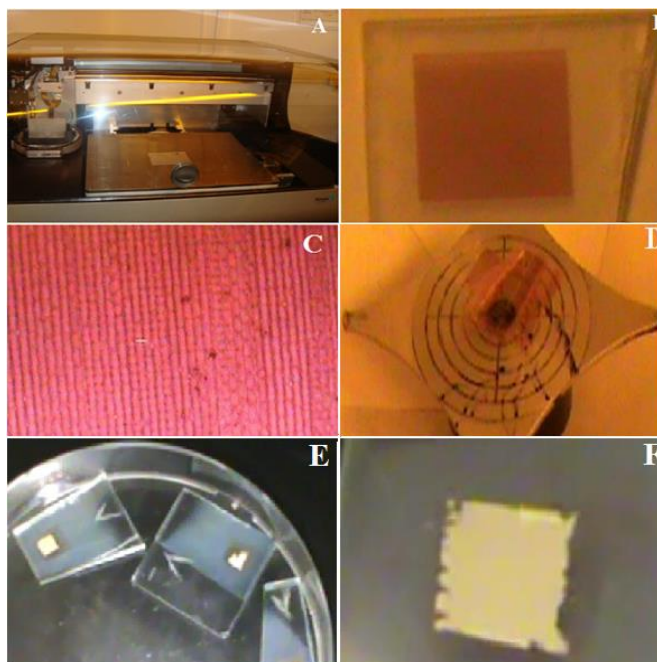
**3.3 Transmission Electron Microscopy (TEM) and Energy-Dispersive X-ray Spectroscopy (EDS):** Sample for TEM were prepared on copper grids (Carbon Type-A, 300 mesh, Ted Pella, Inc.). High resolution images indicate that the quantum dots have a high degree of monodispersity with particle diameters in the range of 4-8 nm. EDS on these quantum dots indicate the expected 1:1 Cd:Te ratio.



**Figure 3.** HR-TEM images of CdTe nanoparticle quantum dots with an average diameter of 6.3 nm.

#### 4. Solar Cell Fabrication

A cartridge for a Dimatix Materials Printer DMP-2800 (Fig. 4A) was loaded with the CdTe quantum dot ink solution and dispensed onto a ZnO-coated indium-tin-oxide (ITO) substrate. Inkjet printing instrumentation and procedures are described in detail elsewhere.<sup>19-21</sup> The coating was formed from three identical layers where each layer has areal dimensions of 7 mm x 7 mm and a thickness of 20-25 nm (Fig. 4B). The layers were then annealed at 140 °C for 10 min and inspected under an optical microscope (Fig. 4C). The solar cell structure was then completed by first spin coating a polymer containing PEDOT:PSS (Poly(3,4-ethylenedioxythiophene) poly(styrenesulfonate) (Fig. 4D) followed by the application of a gold electrode using a sputter coater (Fig 4E-F).



**Figure 4:** Optical images of (A) the Dimatix Materials Printer DMP-2800 used for Printing CdTe quantum dot ink, (B) the substrate after the ink has been printed, (c) the ink after annealing, (D) spin coating of the cell with the PEDOT:PSS polymer, (E) the final cell and (F) the top gold contact.

## 5. Summary

We have demonstrated the viability of fabricating a CdTe quantum dot hybrid solar cell architecture using an inkjet printing process. Crucial to this demonstration was the synthesis of monodisperse CdTe quantum dots exhibiting quantum confinement effects and their subsequent incorporation into an ink formulation. Future work will focus on assessing and optimizing the light harvesting capabilities of the solar cells produced.

## Acknowledgements:

This work was funded by the Energy Commercialization Institute. KDG acknowledges the financial support of the NSF NUE grant No 1042071. We also acknowledge Dr. M. Kiani and Dr. R. Suri for providing access to their facilities.

## References:

- <sup>1</sup> A. V. Shah, H. Schade, M. Vanecek, J. Meier, E. Vallat-Sauvain, N. Wyrche, U. Kroll, C. Droz, J. Baillet, Thin-film silicon solar cell technology, *Prog. Photovolt: Res. Appl.* **12**, 113–142 (2004).
- <sup>2</sup> M. A. Green, Solar cells: Operating principles, technology, and system applications, *Prentice Hall* **18**, 1-274 (1982).
- <sup>3</sup> A. Shah, P. Torres, R. Tscharnner, N. Wyrch, H. Keppner, Photovoltaic technology: The case for thin-film solar cells, *Science* **285**, 692-698 (1999).
- <sup>4</sup> P. Lorenz, D. Pinner, T. Seitz, Solar market powers silicon, *The McKinsey Quarterly* **1**, 1-10 (2008).
- <sup>5</sup> T. D. Nielsen, C. Cruickshank, S. Foged, J. Thorsen, F. C. Krebs, Business, market and intellectual property analysis of polymer solar cells, *Sol. Energy Mater. Sol. C* **94**, 1553-1571 (2010).
- <sup>6</sup> <http://www.nanosolar.com/>
- <sup>7</sup> <http://www.konarka.com/>
- <sup>8</sup> S. Günes, H. Neugebauer, N. S. Sariciftci, Conjugated polymer-based organic solar cells, *Chem. Rev.* **107**, 1324–1338 (2007).
- <sup>9</sup> X. Mathew, J. P. Enriquez, A. Romeo, A. N. Tiwari, CdTe/CdS solar cells on flexible substrates, *Sol. Energy* **77**, 831–838 (2004).
- <sup>10</sup> Y. Zhou, M. Eckab, M. Kruger, Bulk-heterojunction hybrid solar cells based on colloidal nanocrystals and conjugated polymers, *Energy Environ. Sci.* **3**, 1851–1864 (2010).
- <sup>11</sup> A. J. Nozik, Quantum dot solar cells, *Physica E* **14**, 115- 120 (2002).
- <sup>12</sup> I. Gur, N. A. Fromer, C. Chen, Antonios G. Kanaras, A. Alivisatos, Hybrid solar cells with prescribed nanoscale morphologies based on hyperbranched semiconductor nanocrystals, *Nano Lett.* **7**, 409–414 (2007).
- <sup>13</sup> W. U. Huynh, J. Dittmer, A. P. Alivisatos, Hybrid nanorod-polymer solar cells, *Science* **295**, 2425-2427 (2002).
- <sup>14</sup> A. Romeo, M. Arnold, D. L. Bätzner, H. Zogg, A. N. Tiwari, Development of high efficiency flexible CdTe solar cells, *Sol. Energy Mat. Sol. C* **90**, 3407–3415 (2006).
- <sup>15</sup> D. L. Bätzner, R. Wendt, A. Romeo, H. Zogg, A. N. Tiwari, Development of efficient and stable back contacts on CdTe/CdS solar cells. *Thin Solid Films* **387**, 151-154 (2001).
- <sup>16</sup> D. Cunningham, M. Rubcich, D. Skinner, Cadmium telluride PV module manufacturing at BP Solar, *BP Solar* **10**, 159 -168 (2002).

- <sup>17</sup> C. B. Murray, D. J. Norris, M. G. Bawendi, Synthesis and characterization of nearly monodisperse CdE (E = S, Se, Te) semiconductor nanocrystallites, *J. Am. Chem. Soc.* **115**, 8706–8715 (1993).
- <sup>18</sup> **V. Kloper, R. Osovsky, J. Kolny-Olesiak, A. Sashchiuk, E. Lifshitz, The growth of colloidal cadmium telluride nanocrystal quantum dots in the presence of CdO nanoparticles, *J. Phys. Chem.* **111**, 10336-10341 (2007).**
- <sup>19</sup> A. Teichler, R. Eckardt, S. Hoepfner, C. Friebe, J. Perelaer, A. Senes, et al. Combinatorial screening of polymer-fullerene blends for organics solar cells, *Adv. Energy Mater.* **1**, 105-114 (2011).
- <sup>20</sup> C. N. Hoth, S. A. Choulis, P. Schilinsky, C. J. Brabec, High photovoltaic performance of inkjet printed polymer:fullerene blends, *Adv. Mater.* **19**, 3973–3978 (2007).
- <sup>21</sup> C. N. Hoth, S. A. Choulis, P. Schilinsky, C. J. Brabeca, On the effect of poly(3-hexylthiophene) regioregularity on inkjet printed organic solar cells, *J. Mater. Chem.* **19**, 5398–5404 (2009).
- <sup>22</sup> Y. Masumoto, K. Sonobe, Size-dependent energy levels of CdTe quantum dots, *Phys. Rev. B* **56**, 9734–9737 (1997).

## **Remote Wireless Control of a Bottling Process**

DAVID HERGERT, Ph.D.  
Professor, Engineering Technology  
Miami University-Hamilton  
1601 University Blvd.  
Hamilton Ohio 45011  
hergerd@muohio.edu

## **Remote Wireless Control of a Bottling Process**

### **Abstract:**

Over the last ten years, remote wireless monitoring and control has become an integral part of industrial automation systems. Remote monitoring is used in such diverse areas as automobile assembly, oil and process control, analyzing temperature in heat exchangers, deployment of resources on a smart grid, and environmental measurements.

This paper describes a remote wireless monitoring and control system used in a senior level industrial automation course. This course is offered by distance (interactive video) to community colleges in the state. The industrial process consists of Human Machine Interface (HMI) software that utilizes a series of ActiveX controls to operate a Supervisory Control and Data Acquisition (SCADA/HMI) bottling process. The ActiveX controls were written by the author in Visual Studio. Each ActiveX control represents a component in the process, such as a switch, light, bottle, solenoid, cap, and conveyor. Individual components can be displayed and animated by writing code that connects them to the bottling process.

Students use the ActiveX controls to first program a simulation in Visual Studio 2010. They then connect to the bottling system using real time data from the process. Distance students can program Visual Studio to release a solenoid and allow the bottle to move to a fill station and monitor the system while a label and cap is placed on the bottle. The bottling process is controlled by a Remote Terminal Unit (RTU) that is connected to a central data server through MODBUS. Students access the central data server through a static IP address. This course gives students direct experience with modern industrial programmable controllers, wireless industrial networking, Radio Frequency Identification tags (RFID), and MODBUS.

### **Engineering Technology B.S. Program**

The labs described in the course are part of a TAC/ABET accredited +2 B.S. Engineering Technology program that connects with ten community colleges. Students complete a two year engineering technology degree at the community college, then complete the bachelors primarily through live videoconferencing. One of the most challenging aspects of this program is the student laboratory experience. The focus of this paper is on a bottling process that allows for remote monitoring and control.

### **Comments on Engineering Laboratory Instruction**

In the last thirty years there has been “major paradigm shift in technology, starting from analog to digital, macro to micro, from fixed (or wired) communication to mobile (or wireless) communication, etc.”<sup>1</sup>. Tiwari also notes that there is a lag in traditional engineering laboratory experiences, especially with regards to remote monitoring and control. In the case of large equipment, the student is often reduced to spectator. The distance B.S. Engineering Technology program faces even more hurdles since students are in a location separate from the laboratory equipment.

### **Comments from Departmental Industry Advisory Council**

For a number of years the author heard comments from the department’s Industrial Advisory Council regarding topics that needed to be taught in industrial automation. Fifteen years ago it

was SCADA/HMI. Ten years ago it was Structured Query Language (SQL) for databases. Currently the comments revolve around remote monitoring and control of a process (at a recent meeting, one of the advisors showed a live robot in a clean room from Houston on his cellphone). All of these topics have been included in the Industrial Automation course. This course was first offered in Spring 2010. Wonderware was used to teach a local version of the class, but licensing issues prevented its use by distance students. Since the university has a site license for Labview that allows students to download it, consideration was given whether to use it. For example Northern Illinois University<sup>2</sup> is using Labview in a SCADA/HMI environment for an automation course. Also Labview can be fairly easily configured in a client/server environment.

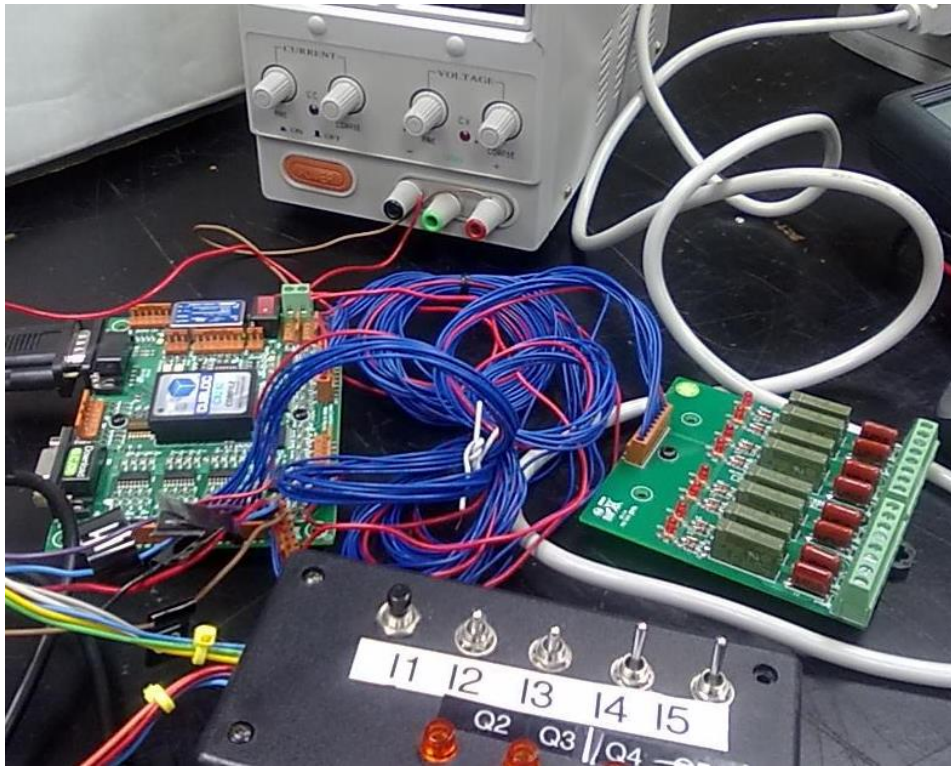
In 2010, a survey was given to 200 graduates, members of the Industrial Advisory Council, and professionals who work in industrial automation. This survey asked what software and programming environments they used related to industrial automation. Six out of 200 respondents used Labview regularly in industry, 40% used Visual Studio in some form, and 85% used some sort of SCADA/HMI software. SCADA/HMI software included GE IFix, Allen Bradley RSView, Visual Studio, and Wonderware. Many also worked with a SQL database in a client/server network. All respondents said teaching of SCADA/HMI was critical to the course. Based on the results of this survey and Wonderware licensing issues, Visual Studio was chosen as an alternative to Wonderware and Labview.

### **Wireless and Wired Communication**

Data is transferred to a computer from a process or machine using either a wired or wireless connection. Wired connections typically are Ethernet or serial. OPC, TCP/IP and Modbus protocols typically use this type of network<sup>3</sup>. Wireless connections normally use radio frequencies to transmit data. Examples include Bluetooth and RFID tags. In the process control industry, wireless communication is increasing in popularity, particularly in predictive maintenance. Here wireless “smart” sensors attached to machinery communicate with a server. The sensors automatically report when a degraded condition occurs on the machine.

### **Industrial Automation Course Prerequisites**

Because of course prerequisites, all students have knowledge of circuit analysis, power electronics, programmable controllers and Visual Studio before starting the industrial automation class. They are required to purchase a CUBLOC 32M Industrial Remote Terminal Unit (RTU) Kit as part of the course. The CUBLOC can be programmed in BASIC or ladder logic and contains analog and digital I/O with relays. It also contains a MODBUS network for connection to other PLC/RTU and PCs. While low cost PLC units are available, the decision to use an RTU was based on improved system performance, communication flexibility, and configurability. Motorola states “In practice, the typical PLC usage model revolves around localized fast control of discrete variables. RTU usage focuses on remote monitoring with control, but with a higher demand for application communications and protocol flexibility<sup>4</sup>.” A photo of the CUBLOC kit is shown in Figure 3:



**Figure 3: CUBLOC 32M with Switches**

Students also purchase an inexpensive RFID reader with tags. The reader can be interfaced to Visual Studio through a serial port.

### **Bottling Process in the Industrial Automation Course**

In 2009, a group of Senior Design students in the program began working on the bottling process. They designed and installed the fluid tanks, solenoids, fill station, label application, and cap feed. The label application proved difficult because it had to be applied at the bottle tipping point. The bottle would tip above or below this point. To find the tipping point, the center of gravity for various fill states had to be calculated.

The cap feed also proved difficult because the bottle tended to turn while the cap was being attached. After calculating the amount of torque needed to turn the cap, a device was designed to hold the bottle in place. The fill station and label feed are shown in Figure 1. Figure 2 shows the gripper of the cap attachment unit.





Figure 1: Bottling Fill Station and Label Feed

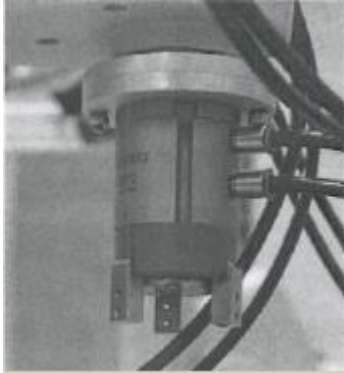


Figure 2: Cap Gripper

### **Industrial Automation Course Projects:**

Currently students perform the following lab projects related to remote wireless monitoring and control as part of the Industrial Automation course.

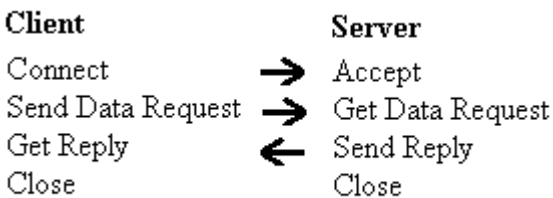
- Program a TCP/IP client/server application in Visual Studio.
- Connect a MODBUS network from the CUBLOC to Visual Studio.
- Simulate a bottling process using Active X controls.
- Program an RFID reader.

- Write client/server code to remotely select a flavor and start an actual bottling process using the RFID reader.
- Write client/server code read in data and display a real time simulation of the bottling process.
- Connect to an SQL database and send data from the process to it.

The following is a description of each lab project:

### Program a TCP/IP Client/Server

All students write code to create a local client/server connection on their computer. The connection between the client and server is shown in Figure 4.



### Figure 4: Client/Server Connection

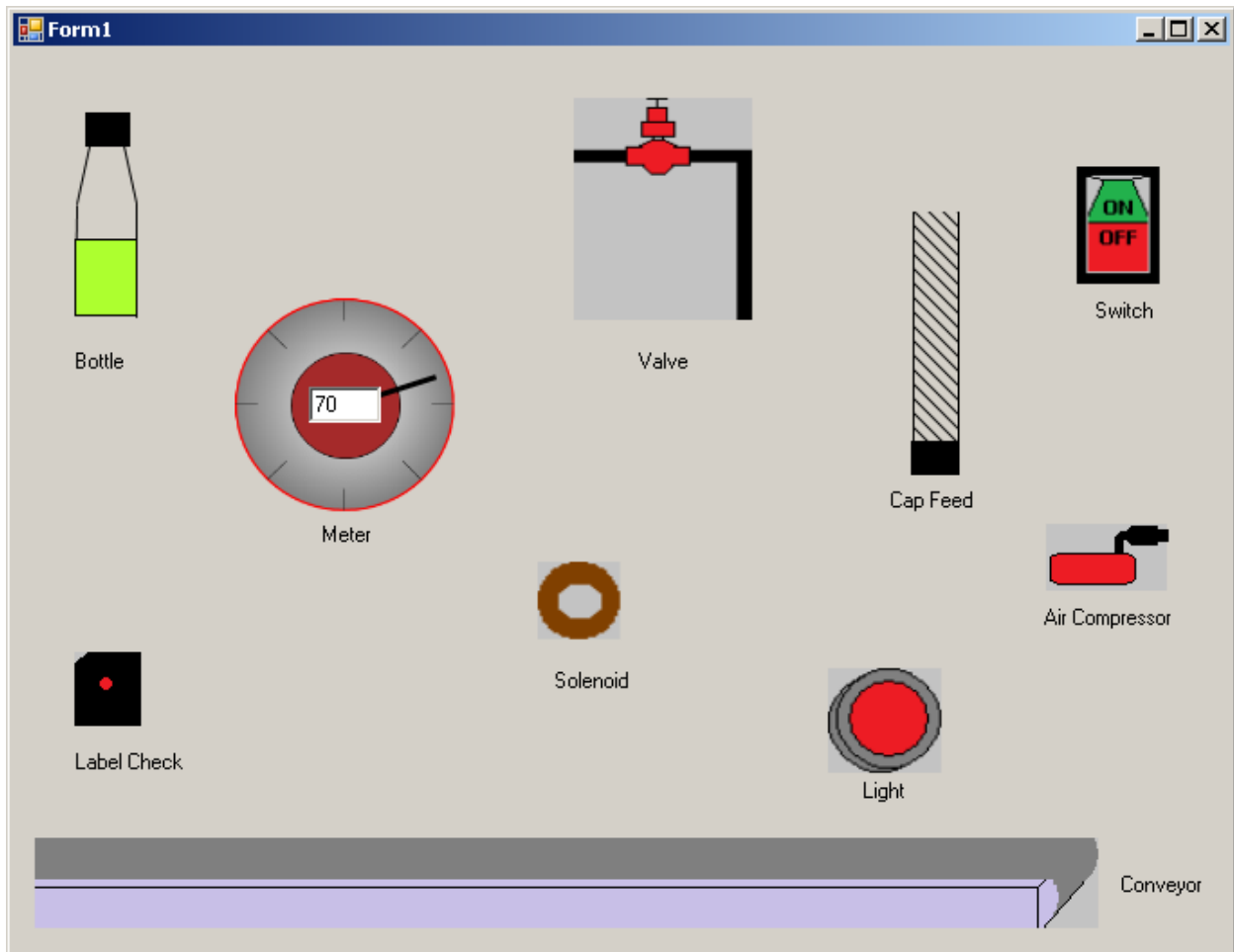
Students practice sending data between a TCP/IP client and server utilizing network streaming and binary read/write commands. Sample code fragments given to the students are outlined in the appendix. The O'Brien text is a good reference on how to do this<sup>5</sup>.

### Connect a MODBUS Network

For this lab project, students first connect two CUBLOCs through a MODBUS network. They then have the switches on one RTU control the lights on the other. After successfully completing this, they write code to read the RTU data tables into Visual Studio using MODBUS.

### Simulate a Bottling Process Using ActiveX Controls

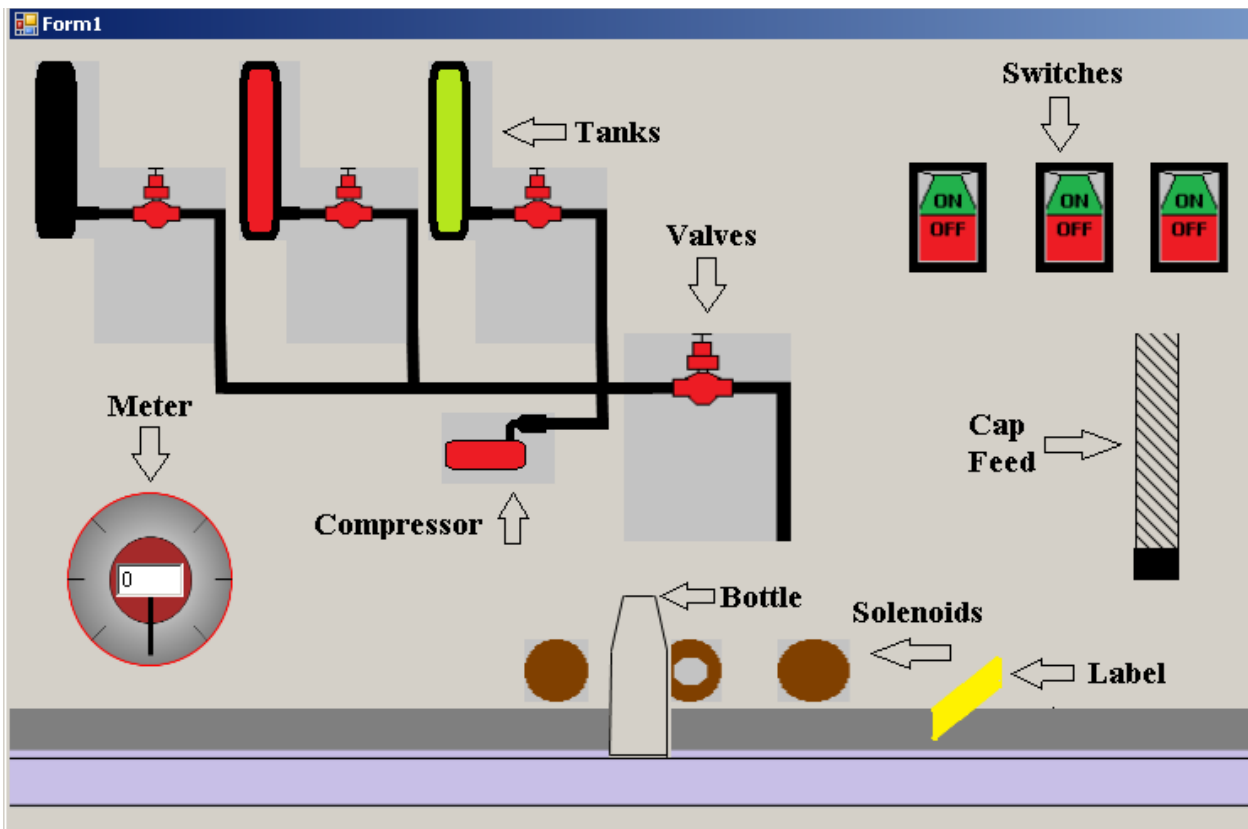
SCADA/HMI is introduced through programmable ActiveX Controls in Visual Studio. These controls were written by the author. Students learn basic animation techniques in order to size and move the controls.



**Figure 5: Visual Studio Active X Controls**

For example the bottle control can be programmed to fill with various colors and have a cap placed on it. The meter can be scaled, and the light, valve, switch, label check, and air compressor can be turned on and off. This is done by setting variables in each control. Controls can be resized as needed.

Students load the controls onto the Visual Studio menu and activate them based on input received from switches on the screen. An example of the simulated HMI environment is shown in Figure 6:

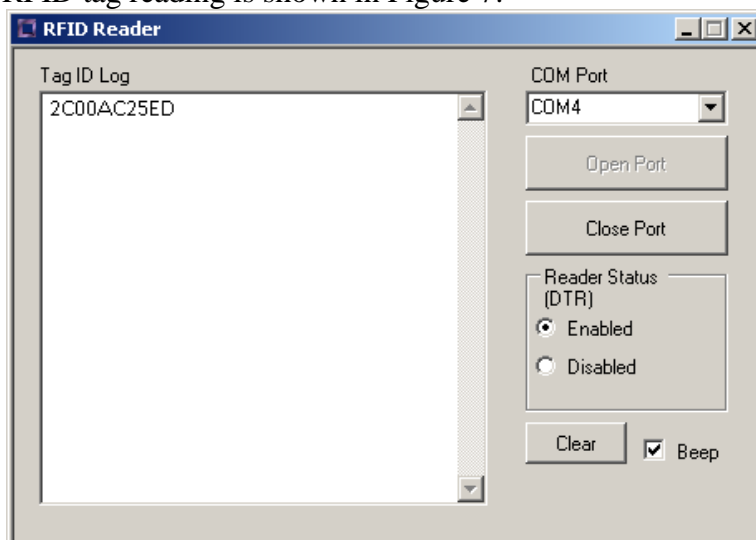


**Figure 6: Simulated HMI Bottling Process**

Sample code that sets the scale of the meter, determines the fill state of the bottle and turns a valve on is shown in the appendix.

### Program an RFID Reader

RFID tags have become an important part of inventory management. Prior to 2011, barcodes were used in the industrial automation course to inventory the bottles in the process. Beginning in the Spring 2011, each student is now required to purchase and program an RFID reader as part of the course. The RFID is eventually used to select a flavor for the bottling process. The intent here is to help students become familiar with wireless ID tags. A sample screen showing an RFID tag reading is shown in Figure 7:

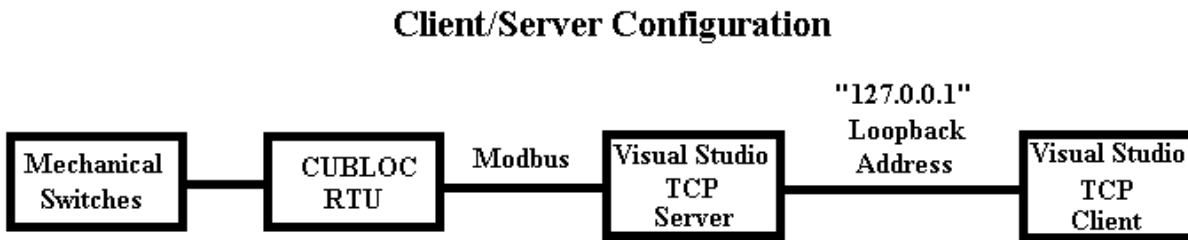


### Figure 7: RFID Reader

Code to access a serial port for the RFID reader is shown in the appendix.

### Connecting to CUBLOC

The connection to the simulated bottling process on a local client/server is shown in Figure 8.

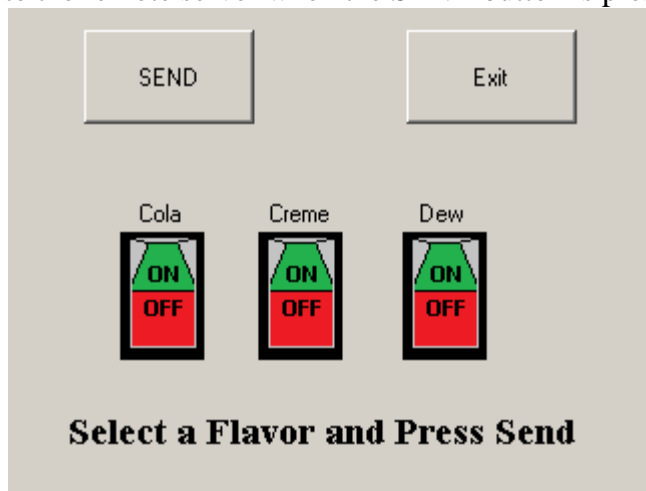


### Figure 8: Bottling Client/Server Configuration

Students first write a CUBLOC BASIC routine to read in the switches and send their states over a MODBUS network to a PC. Visual Studio then sends the packet over a 127 local loopback address to a Visual Studio client programmed on the same machine. Students write all of the code for the CUBLOC and Visual Studio. The intent of this lab project is to help students prepare for a remote connection.

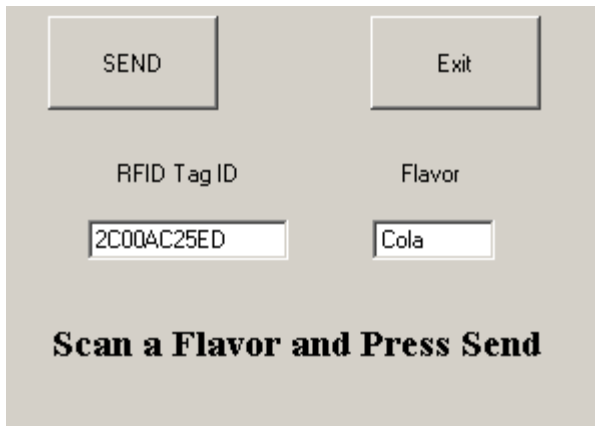
### Write Code to Control a Real Time Remote Bottling Process

Next students write code to send data to a remote server. The server has a static IP address and is accessed through a VPN client. Students place ActiveX switches on the screen and pass the data to the remote server when the SEND button is pressed



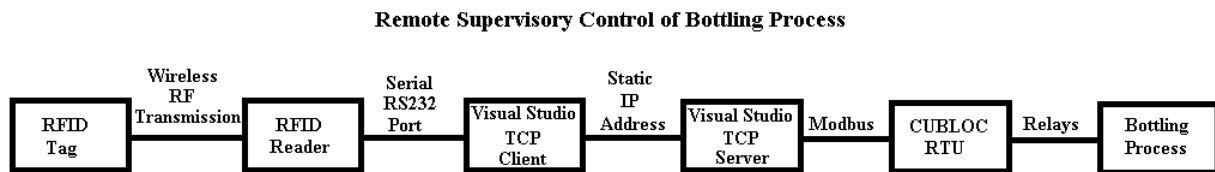
### Figure 9: Flavor Selection Using Switches

Once the server receives a flavor, it sends a command through MODBUS to a CUBLOC that starts the process. After this lab project is completed, students revise the program to select the flavor using an RFID tag instead of a switch. The revised screen is shown in Figure 10:



**Figure 10: Flavor Selection Using RFID Tags**

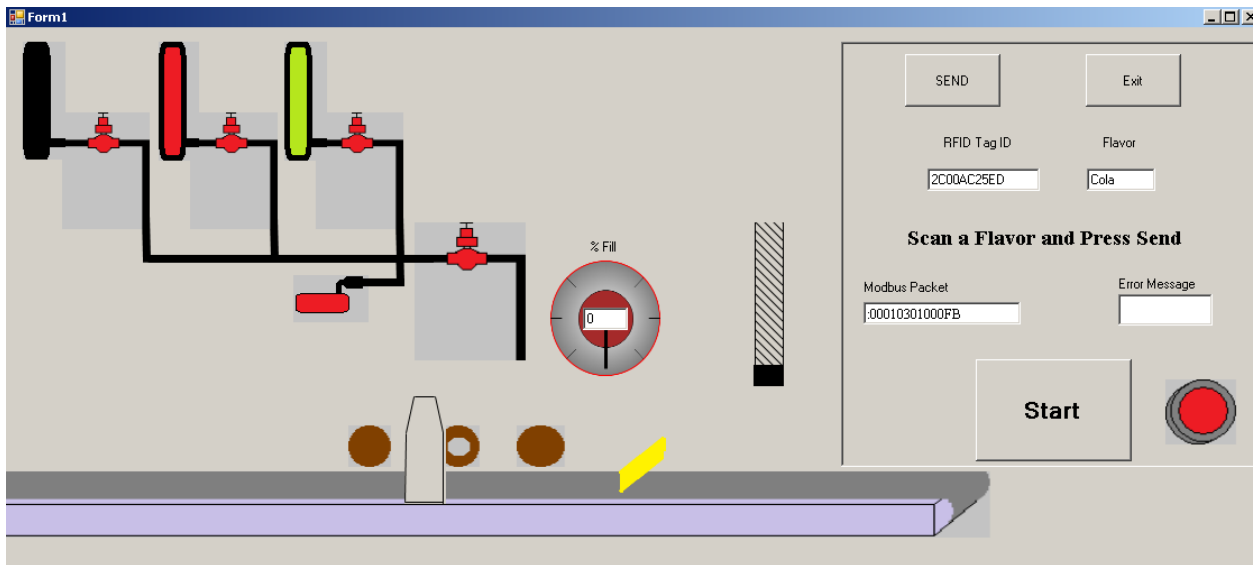
The data path from the RFID tag to the bottling process is shown in Figure 11:



**Figure 11: Remote Supervisory Control of a Bottling Process**

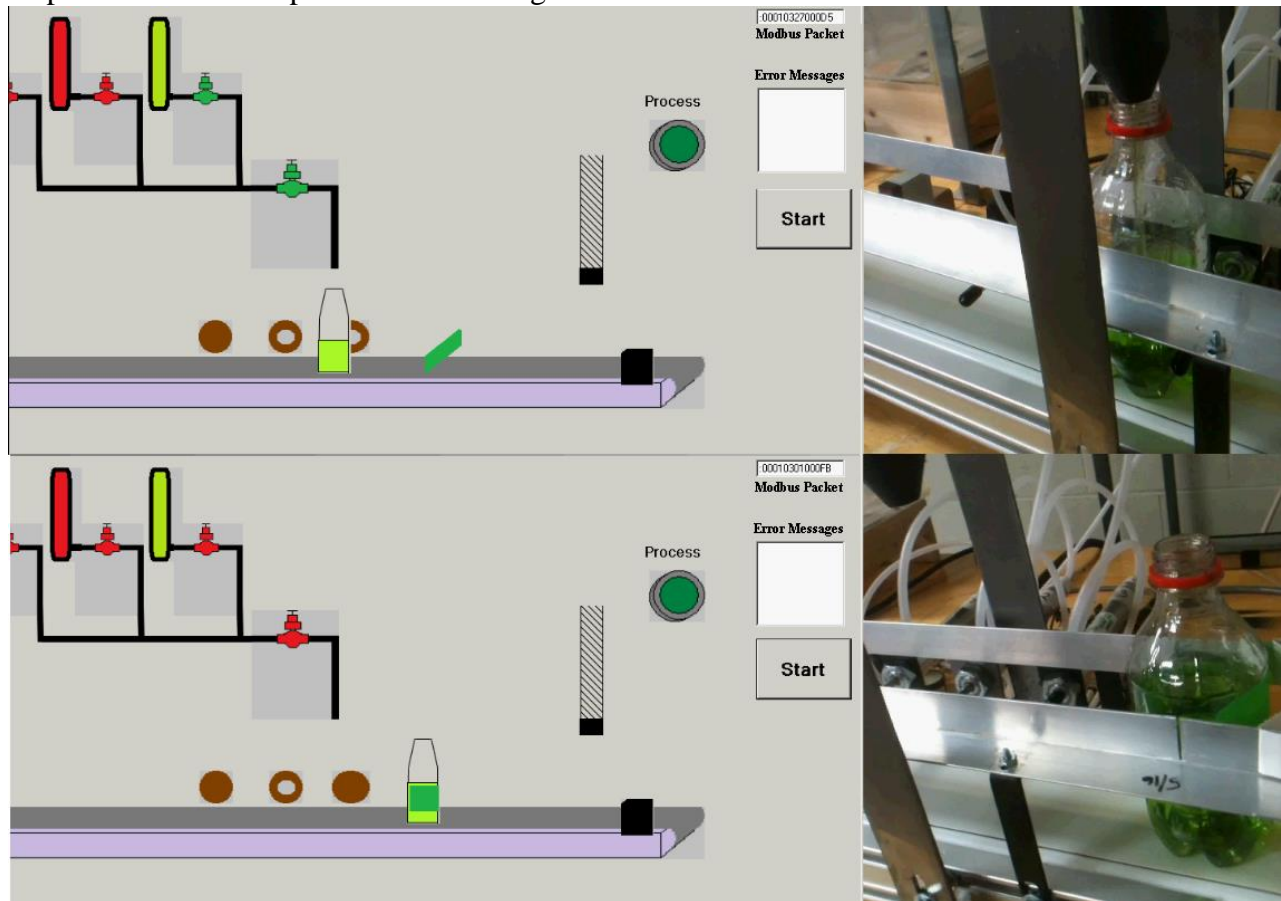
### Receive Data from the Remote Server and Display as an HMI

Next students write code to receive data from the remote server and use it to control the animation on their screen. Data is received as a MODBUS packet that must first be decoded. A sample HMI is shown in Figure 12:



**Figure 12: HMI Showing RFID Flavor Selection and Animation**

The picture in Figure 13 was taken from a student's computer screen. It shows their HMI on the left, with the bottle being filled on the top panel and a label applied on the bottom panel. A video snapshot of the actual process is on the right.



**Figure 13: HMI and Video Screen Interface to an SQL Database**

After students complete the programming for the remote bottling process, they write code to connect and pass data to an SQL database. This is sometimes the most difficult part of the course. Flavors selected by the bottling process in a given day are passed by the server to the client. The flavors are then passed to SQL Management Studio through a Visual Studio BindingSource, Data Set, Table Adapter, and DataGridView. The Visual Studio template showing the DataGridView is shown in Figure 14:

	Cola	Creme	Dew	Time	Date
	2	1	2	01:00:07	05-17-2011
	0	1	0	01:08:21	05-18-2011
	2	1	3	2:12:07	06-10-2011
	2	1	3	2:12:07	06-30-2011
	1	2	0	2:12:07	07-22-2011
	1	2	0	13:39:09	07-23-2011
	1	2	6	14:39:09	07-27-2011

Save To SQL Management Studio

**Figure 14: Visual Studio DataGridView**

The SQL Management Studio showing sample data read from Visual Studio is shown in Figure 15, and the Binding Source and Table Adapter are shown in Figure 16.

The screenshot shows the SQL Server Enterprise Manager interface. The query editor contains the following SQL query:

```
Select Bottling.*
from Bottling where Date = '05-17-2011'
```

The Results pane shows a single row of data:

	Cola	Creme	Dew	Time	Date
1	2	1	2	01:00:07	05-17-2011

The status bar at the bottom indicates: Query exec... C:\Bottles\Bottles.sdf SQL Server Compact Edi... 3.5.8080.0 00:00:00 10 rows

**Figure 15: SQL Management Studio**

The screenshot shows two Properties windows side-by-side. The left window is for **BindingSource1** (System.Windows.Forms.BindingSource) and the right window is for **BottlingTableAdapter** (WindowsApplication1.Bottles).

**BindingSource1 Properties:**

- AllowNew: True
- Data:
  - (ApplicationSettings):
  - DataMember: **Bottling**
  - DataSource: **BottlesDataSet**
  - Filter:
  - Sort:
- Design:
  - (Name): **BindingSource1**
  - GenerateMember: True
  - Modifiers: **Friend**

**DataSource:** Indicates the source of data for the BindingSource.

**BottlingTableAdapter Properties:**

- Data:
  - (ApplicationSettings):
- Design:
  - (Name): **Bottling TableAdapter**
  - GenerateMember: True
  - Modifiers: **Friend**
- Misc:
  - ClearBeforeFill: **True**

**(Name):** Indicates the name used in code to identify the object.



## Figure 16: Visual Studio Binding Source and Table Adapter

Sample Visual Studio code for SQL connections is shown in the appendix.

### Future Work

Senior Design students in the program are currently redesigning the bottling process to auto configure for various bottle sizes. It will then be used as a flexible automation demonstration in a Modern Manufacturing course.

A second group is working on bottle size and label recognition using a camera and image processing.

A third group is working on palletizing the bottles using a robot. It will adjust for various size bottles when packaging.

Finally the author is currently working on developing an iPad style app using HTML5 that would allow students to control and monitor the process.

### Conclusions

While RFID tags are not a necessary component of a bottling process, the intent is to give students at the distance sites some exposure to wireless communication. In industry, the popularity of RFID tags has rapidly increased. In 2005 it was predicted that they would soon replace barcodes for inventory applications<sup>6</sup>. However at present this has not been the case. Communication problems (including noise and ground plan interference<sup>7</sup>) are the primary reason their use has leveled off. Still, RFID tags are increasing being used as a method of inventory tracking and identification.

Feedback from the departmental Industrial Advisory Council on the bottling process labs has been very positive.

### Bibliography

1. Tiwari, R., Singh, Khilawan. "Virtualisation of Engineering Discipline Experiments For an Internet-Based Remote Laboratory", Australasian Journal of Educational Technology, pp 671-692
2. Otieno, A. "Development of SCADA Experimental Systems Through Student Projects To Enhance the Automation Curriculum in a Manufacturing Engineering Technology Program", ASEE Annual Conference Proceedings 2007
3. [http://www.reliabilityweb.com/articles/remote\\_machinery\\_condition\\_monitoring.pdf](http://www.reliabilityweb.com/articles/remote_machinery_condition_monitoring.pdf)
4. [http://www.motorola.com/web/Business/Products/SCADA%20Products/\\_Documents/Static%20Files/SCADA\\_Sys\\_Wht\\_Ppr-2a\\_New.pdf](http://www.motorola.com/web/Business/Products/SCADA%20Products/_Documents/Static%20Files/SCADA_Sys_Wht_Ppr-2a_New.pdf)
5. O'Brien B, Seaver C, Microsoft Visual Basic.NET Programming Essentials ,pp 290-353 Microsoft, 2004
6. <http://www.ciupdate.com/trends/article.php/3550656/RFID-Gaining-in-Popularity.htm>
7. P. Raunonen, L. Sydanheimo, L. Ukkonen, M. Keskilammi, M. Kivikoski, "Folded dipole antenna near metal plate," Antennas and Propagation Society International Symposium, 2003.

## **Appendix:**

### **Sample RS232 serial port commands:**

```
'Declare com1 as serial port
Dim com1 As IO.Ports.SerialPort = Nothing

'Set to COM4
com1 = My.Computer.Ports.OpenSerialPort("COM4")

'Set to 9600, no parity, 8 bits, 1 stop bit
com1.BaudRate = 9600
com1.Parity = IO.Ports.Parity.None
com1.DataBits = 8
com1.StopBits = 1

'Set Handshaking
com1.DtrEnable = False
com1.RtsEnable = False

'Time out after 10 seconds
com1.ReadTimeout = 10000

If com1 IsNot Nothing Then
'Read byte from COM4
Reading = Val(com1.ReadByte())

'Place reading in text box
TextBox2.Text = Reading

'Close connection
com1.Close()

End If
```

### **Sample ActiveX Commands**

```
'Turn Valve 2 on
Valve2.State.Text = "On"

'Select Brand
BottleFill1.Brand.Text = "Cola"

'Set Fill Level to 50%
BottleFill1.FillLevel.Text = 50

'Move Bottle to left 10 pixels
BottleFill1.Left= BottleFill1.Left+10

'Display Label
```

```
BottleFill1.Label.Text = "On"
```

```
'Set minimum scale on meter  
Meter1.Minimum.Text=0
```

```
'Set maximum scale on meter  
Meter1.Maximum.Text=100
```

```
'Set scale reading to 70  
Meter1.Reading.Text=70
```

### **Sample TCP/IP Client Connection**

```
'Dim Client  
Dim Client As New TcpClient  
  
'Connect to Loopback Address 127.0.0.1, port 8000  
Client.Connect(("127.0.0.1"), 8000)  
  
'Dimension network stream and binary read/write  
Dim Stream As NetworkStream = Client.GetStream()  
Dim r As New BinaryReader(Stream)  
Dim w As New BinaryWriter(Stream)  
  
'Request a connection from server  
w.Write(ClientMessages.RequestConnect)  
  
'Wait for response from server  
If r.ReadString() = ServerMessages.AcknowledgeOK Then  
  
'Send contents of TextBox1  
w.Write(TextBox1.Text)  
  
'Disconnect from server  
w.Write(ClientMessages.Disconnect)  
End If  
  
'Close network connection  
Client.Close()
```

### **Sample Code To Configure Visual Studio for SQL Connection**

```
Dim tableadapter As New BottlesDataSetTableAdapters.BottlingErrorsTableAdapter
```

```
tableadapter.Insert(TextBox1.Text)  
tableadapter.Fill(BottlesDataSet.BottlingErrors)  
tableadapter.Update(BottlesDataSet.BottlingErrors)
```

**Nonlinear Image Enhancement  
For Efficient Pattern Recognition**

M. Nazrul Islam and Brian Aufiero  
Email: [islamn@farmingdale.edu](mailto:islamn@farmingdale.edu)  
Farmingdale State University of New York,  
2350 Broad Hollow Road,  
Farmingdale, New York

Brian Aufiero  
Farmingdale State University of New York,  
2350 Broad Hollow Road,  
Farmingdale, New York

# NONLINEAR IMAGE ENHANCEMENT FOR EFFICIENT PATTERN RECOGNITION

*M. Nazrul Islam and Brian Auflero*

Email: islamr@farmingdale.edu

Farmingdale State University of New York, 2350 Broad Hollow Road, Farmingdale, New York

**Abstract:** Pattern recognition involves image processing techniques to automatically detect and identify a prescribed target or object of interest in a given unknown input scene. Among several challenges faced by pattern recognition techniques is the poor quality of the recorded image in a practical environment. Insufficient light, nonuniform lighting condition, blurry and noisy image, are the major imaging problems which cause practical target detection methods to fail in many situations. Therefore, the recorded input scene images are required to be pre-processed to enhance the quality. Linear image enhancement techniques can only brighten the whole image, but leaves some portions of the scene unclear. We have developed a nonlinear image enhancement scheme which can brighten darker pixels while darken the brighter pixels in order to make all the information in the given scene clearly visible. A dynamic method is also developed which can investigate a given scene and then determine the enhancement parameters. An image segmentation algorithm is also developed in order to crop the objects of interest from the input scene so that the pattern recognition technique does not need to compare the whole input scene with the reference image. Computer simulation investigations verify the effectiveness of the proposed technique in different practical scenario.

**Key Words:** image enhancement, pattern recognition, image segmentation, target tracking.

## INTRODUCTION

Automatic detection and identification of a target or object of interest in a given input video/still scene is of great challenge in the fields of pattern recognition, target tracking and security systems. Image processing techniques have been playing the major role in analyzing a scene to recognize the targets based on either the spatial features or characteristic features derived from the reference object through different transform methods. The major challenge in designing such pattern recognition technique is the real-time implementation which requires simple architecture and very high processing speed. An optical joint transform correlation (JTC) based pattern recognition is developed in this work which offers very high processing speed, simultaneous detection of multiple objects with a high discrimination between target and non-target objects.

Another crucial issue with automatic pattern recognition techniques is the poor image quality of the recorded scene. Practical environmental conditions may, in many cases, affect the recording/sensing process such that the image suffers from insufficient light, nonuniform brightness, blur and noise. Regular enhancement techniques are found to be not effective in most of the situations because they utilize linear brightness enhancement.

The objective of this paper is to develop a nonlinear image enhancement technique which can improve the visibility of a recorded scene under variable illumination conditions. An image segmentation scheme is also incorporated to crop the objects of interest from the given scene in order to reduce the spatial size for image comparison. Performance of the optical JTC based pattern recognition technique including the image enhancement and segmentation algorithms is investigated through computer simulation involving real-life images.

## IMAGE ENHANCEMENT

### Nonlinear Function

Different nonlinear enhancement function is developed and investigated to enhance the quality of a given image. The first nonlinear algorithm considers a simple exponential expansion function, where the input image,  $f(x, y)$ , is enhanced to an output image,  $g_1(x, y)$ , using the following relation

$$g_1(x, y) = f(x, y)^m \quad (1)$$

where  $m$  is the enhancement factor, and  $x$ , and  $y$  are the spatial dimension variables.

Figure 1 shows a simulation result by applying the above-mentioned technique on an input image shown in Fig. 1(a). It can be obvious from Figs. 1(b) and (c) that the algorithm is successful in enhancing an image in specific cases but cannot be utilized for dynamic image enhancement purpose.

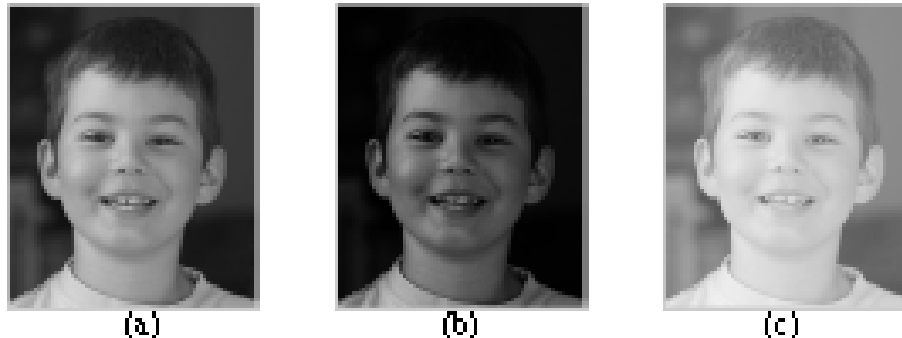


Figure 1: Image enhancement by nonlinear function: (a) original image, (b) enhanced image with  $m = 2$ , (c) enhanced image with  $m = 0.4$

### Exponential Function

The next nonlinear algorithm employs an exponential function for enhancing the given image. The output image,  $g_2(x, y)$ , is given by

$$g_2(x, y) = [f(x, y)]^{m \cdot (1 + \cos(\pi/2))} \quad (2)$$

Figure 2 shows the percentage improvement of each pixel intensity against the given normalized pixel value. It can be observed that the algorithm brightens the medium-intensity pixels while keeps the absolute black and absolute white pixels the same. Figure 3 shows the simulation result by applying the technique on the same input image as in Fig. 3(b).

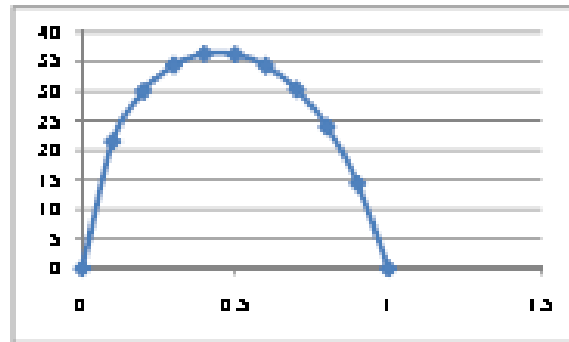


Figure 2: Percentage improvement of pixel values

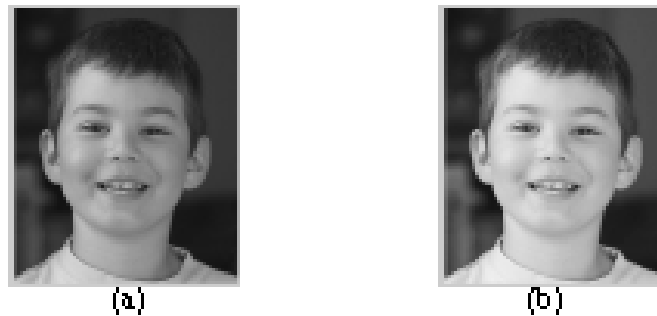


Figure 3: Image enhancement by exponential function of Eq. (2): (a) original image, (b) enhanced image

Another exponential function is investigated for enhancing the given image, where the output image,  $g_1(x, y)$ , is given by

$$g_1(x, y) = [f(x, y)]^{*0.5 \ln B} \quad (3)$$

This function has the similar impact on individual pixel intensities. However, this algorithm is found to darken the given image as shown in Fig. 4, which means that it is effective in improving images which are recorded under too bright lighting condition. Several other forms of exponential functions are also investigated in order to find a suitable enhancement algorithm.

Then the algorithm is updated by incorporating a global thresholding scheme to automatically control the enhancement process. For this purpose, first an average of the pixel intensities of the entire image is calculated and compared to a threshold. The image is being enhanced through exponential functions until it reaches a normalized average pixel intensity within the range of 0.45 to 0.55. Figure 5 shows a set of simulation results of the adaptive exponential enhancement technique. As shown in Figs. 5(a), 5(b) and 5(c), the same target face is recorded but with different brightness conditions. However, the proposed technique is successful to enhance the different images to increase the visibility and at the same time bring them to a uniform intensity level as can be obvious from Figs. 5(b), 5(d) and 5(f).



Figure 4: Image enhancement by exponential function of Eq. (3): (a) original image, (b) enhanced image

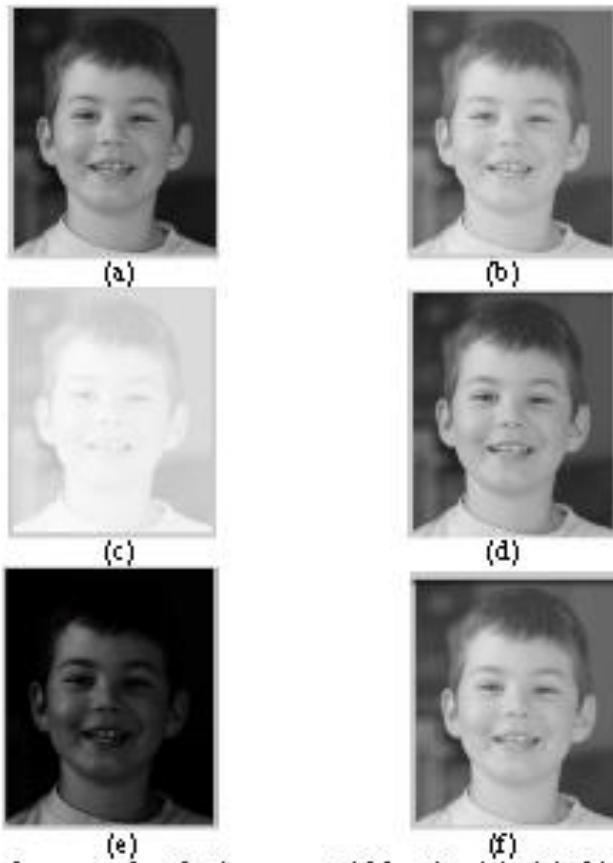


Figure 5: Image enhancement by adaptive exponential function: (a) original image, (b) enhanced image, (c) original image, (d) enhanced image, (e) original image, (f) enhanced image



## IMAGE SEGMENTATION

Another objective of this research is to develop an image segmentation technique in order to crop the image portion which retains only the face. For this purpose, first a face recognition algorithm is incorporated which provides with outline boxes around a face. From the boxes the biggest box is selected by ignoring any smaller boxes inside of it. After cropping the image for the first box, the pixels inside that box are set to zero (black). Then the average of the pixels is checked if it is zero so that it can be decided whether the selected box is within another box and can be ignored. Figures 6 shows the simulation results of image segmentation techniques on a test face image.



Figure 6: Image segmentation: (a) original image, (b) background image, (c) cropped face

## PATTERN RECOGNITION

A modified optical JTC based pattern recognition is developed as shown in the block diagram of Fig. 7. The reference face image, which will be searched for in the input image, is fed to the system in four parallel channels after phase shifting by  $0^\circ$ ,  $90^\circ$ ,  $180^\circ$  and  $270^\circ$ , respectively. Then the given input scene is introduced to the phase-shifted reference images to form four different joint images,  $d_n(x, y)$ , as given by

$$d_n(x, y) = j^{n-1} r(x, y) + s(x - x_n, y - y_n) \quad (4)$$

$n = 1, 2, 3, 4$

where  $r(x, y)$  and  $s(x, y)$  indicate the reference and unknown input, respectively, images.

The joint images are Fourier transformed to generate four different joint power spectra (JPS) as given by

$$P_n(u, v) = |D_n(u, v)|^2 = |R(u, v)|^2 + |F(u, v)|^2 + j^{-n-1} R(u, v) F^*(u, v) \exp(ju x_n) \exp(jv y_n) + j^{-n-1} R^*(u, v) F(u, v) \exp(-ju x_n) \exp(-jv y_n) \quad (5)$$

where  $u$  and  $v$  are the Fourier domain variables.

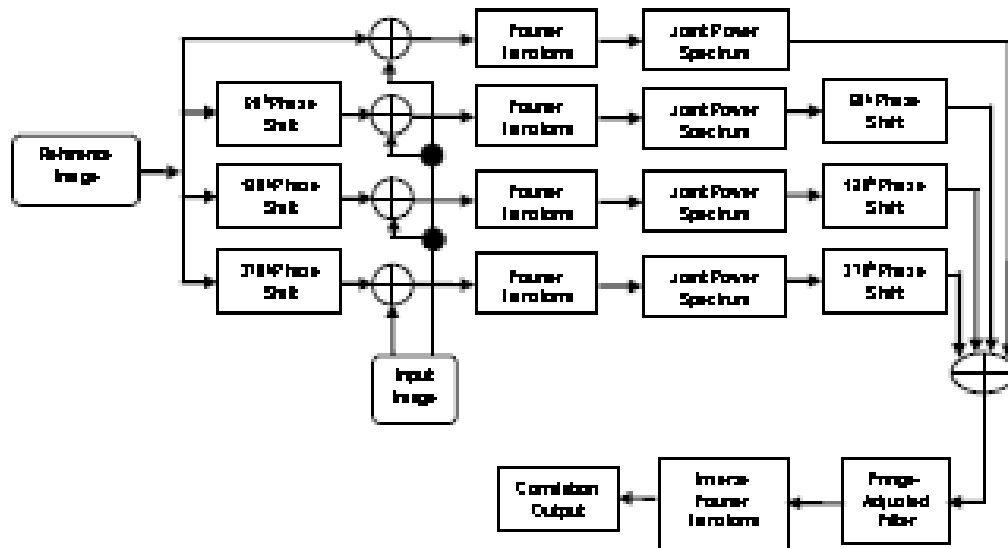


Figure 7: Block diagram of the proposed pattern recognition scheme

Then the proposed technique incorporates the following algebraic operation to eliminate any extraneous correlation terms automatically.

$$\begin{aligned}
 P(u, v) &= P_1(u, v) + jP_2(u, v) - P_3(u, v) - jP_4(u, v) \\
 &= 4R^*(u, v)F(u, v)\exp(-jux_1)\exp(-jvy_1)
 \end{aligned}
 \tag{6}$$

As can be obvious from Eq. (6) that the final JPS signal contains only the desired cross-correlation term and also the correlation peak occurs exactly at the target location. Inverse Fourier transformation of Eq. (6) yields the correlation output.

Figure 8(a) shows the joint input image containing the reference face image on the left top corner of the plane, while the rest of the plane includes six different face images in the unknown input scene. It can be observed in the correlation output shown in Fig. 8(b) that the technique recognizes the target face by producing a very sharp peak at the target locations while rejecting all non-target face images by producing negligible peaks. The face recognition performance is not dependent on the number of objects or complexity of the given input scene.

## CONCLUSION

A novel and efficient pattern recognition technique is presented in this paper. The proposed technique includes three processing components, image enhancement, image segmentation and pattern recognition. An adaptive nonlinear function is developed to enhance the visibility of the recorded scene. The algorithm can automatically adjust the enhancement parameters to bring different images to a uniform brightness level. The image segmentation component crops the target or object of interest from the given scene in order to reduce the pattern recognition processing time. Optical JTC based pattern recognition technique is developed which can

identify the target objects successfully and with a high discrimination between target and background objects. The proposed technique can yield real-time target detection and target tracking systems for practical implementations.

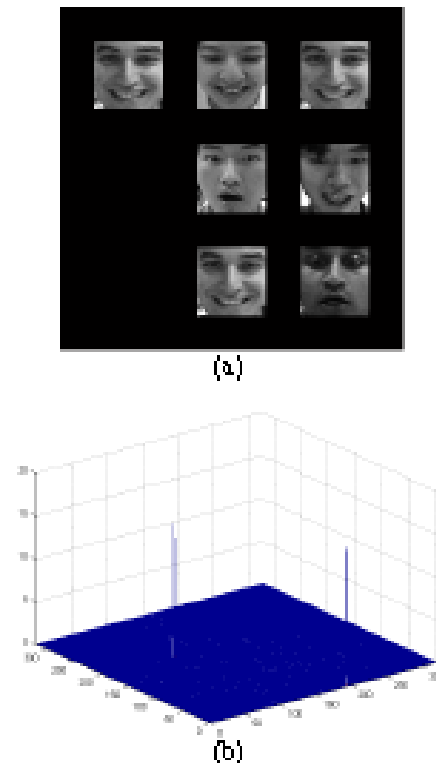


Figure 8: Race recognition performance: (a) joint input image, (b) correlation output.

## REFERENCES

- [1] S. Arigela and V. K. Asari, "Adaptive and nonlinear techniques for visibility improvement of hazy images," *Lecture Notes in Computer Science*, Published by Springer, *Advances in Visual Computing*, Edited by G. Bebis et al. *Proceedings of the International Symposium on Visual Computing (ISVC 2011)*, Las Vegas, NV, USA, vol. 6939/2011, pp. 75-84, 26-28 September 2011.
- [2] R. Patel and V. Asari, "A Neighborhood dependent nonlinear technique for color image enhancement," *Lecture Notes in Computer Science*, Published by Springer-Verlag Berlin/Heidelberg, *Image Analysis and Recognition*, Edited by Amélio Campilho and Mohamed Kamel, *Proceedings of the International Conference on Image Analysis and Recognition (ICIAR 2010)*, Porto, Portugal, vol. 6111/2010, pp. 23-34, 21-23 June 2010.
- [3] I. Pollok, A. S. Wilsky and H. Krim, "Image segmentation and edge enhancement with stabilized inverse diffusion equations," *IEEE Transactions on Image Processing*, vol. 9, no. 2, pp. 256 -266, Feb. 2000.
- [4] M. N. Islam, K. V. Asari and M. A. Karim, "Optical pattern recognition using multiple phase-shifted-reference fringe-adjusted joint transform correlation," *Optical Engineering*, vol. 47, no. 9, pp. 097204-1 -097204-9, 2008.

**While fundamentals are essential in the undergrad Engineering Education  
Curriculum  
They are by no means sufficient**

Barrie Jackson  
Department of Chemical Engineering  
Queen's University, Kingston, Ontario Canada

**While fundamentals are essential in the undergrad Engineering  
Education Curriculum  
They are by no means sufficient**

Barrie Jackson  
Department of Chemical Engineering  
Queen's University, Kingston, Ontario Canada

**ABSTRACT**

As a chemical engineer with over thirty years international experience with the Shell group and a subsequent more than twenty year adventure as an adjunct associate professor at Queen's University I have observed some profound changes in the Engineering Profession as well as in the education of proto engineers.

The core body of knowledge expected of a graduate in Chemical engineering has been expanding at a considerable rate. The impact of the computer has been profound as has the impact of new technologies. In my experience faculty (who to a significant degree have no industrial experience to speak of) seem to be more interested in the esoteric rather than the basic fundamentals of sound reliable process engineering. A comment was made at a conference at the University of Michigan that in many respects academe has drifted so far from the "Engineering Professional Skills" that a realistic communication is often not possible

It has often been stated that Sputnik had a profound impact on Engineering Education. As a result of the large degree of concern in the West and in particular United States, Science essentially crowded out Engineering in many Universities

At a recent FIE conference a senior officer of NSF pointed out to me that when we graduated in some cases 50 years ago life was so much simpler and most new grads could make some modest contribution to their employer's workplace with the limited amount of material they had been exposed to while at University. Today this is simply not the case. In my case I was extremely fortunate to be in an organization where I must admit I got most of my engineering education from excellent mentors and coaches.

In Canada the rapid growth of the community college system which at the present time attracts more students than the Universities, has in some quarters become known as the best grad school for engineering graduates. The issue here is that the job market for new graduates is no longer as good as it has been and many new grads have found that further education in the practice of engineering can be invaluable when looking for employment.

Some of the important issues in professional practice are the regulation environment which continues to become more restrictive and compliance issues much more common. Other vital issues in a chemical engineer's education are the issues of Loss and Process Safety Management as well as process troubleshooting.

To cover the obligatory fundamentals of Mathematics and the Sciences such as Chemistry as well as design and "soft Issues" such as communication in a four year program and to meaningfully introduce the issues of Professional Skills mentioned above would appear to be virtually impossible.

While the co-op model at some Canadian Universities tends to address this problem, at Queen's we have our TEAM program where a truly multi-disciplinary

**team of senior students carry out a “consulting” project for a fee paying Industrial client. In our view learning in the context of application, while not appropriate for all learning styles has shown to be effective for most students.**

**This paper will discuss the Technology Engineering and Management program, what we hope to accomplish and present some feedback from TEAM participants over the years.**

## **Introduction**

What I hope to achieve in this paper is a considered reflection on my personal experience in the field of Engineering Education, what I have observed over some twenty some years as an adjunct Associate Professor of Chemical Engineering. It is of interest to me the history of the evolution of Engineering Education to the point where research is the driving force of most Universities. Having been a practising professional for over thirty years, I am aware that our graduates need a balanced approach to education, not a purely science approach. I have had a profound interest in the process of learning and I sincerely believe as many others do that change is essential in the sphere of education of proto engineers. Lastly I intend to describe the TEAM program with which we try to address some of the needs of our students. .

At an FIE conference a few years ago I was discussing how the requisite core body of knowledge expected of a Chemical Engineering graduate has expanded dramatically since he and I graduated in the middle 1950's. At that time what little we took with us from University had some modest value to our employer, but today that simply is rarely the case.

I was fortunate in joining a company, Shell Canada that at the time had a policy of a two year internship where a new grad spent time in various refinery units. My first design experience was a challenge since most of the methods and principles were something I had never heard of before. Although at that time most of the principles of the MESH equations that had to be solved in order to calculate the anticipated behaviour of a fractionation column, a separation device which was and still is the mainstay of the petrochemical and refining industries, were well known. The problem was that it simply wasn't possible to solve these iterative equations with a slide rule. Mostly “Short-cut” procedures were used and a most generous over design was applied. Many columns of that era were “de-bottlenecked” several times. Capital and Operating costs were not as critical in that era.

This all began to change with the advent of the computer, and the other quite important change was that computers allowed the designer to better represent the phase behaviour of the mixtures and provide better estimates of physical and thermodynamic properties of the compounds or mixtures involved.

In my case by the time I “early retired” I had become quite expert in my field of Chemical Process Development, Process Design, and Process Troubleshooting. All this knowledge was acquired from some of the best mentors and coaches in the field that one could ask for.

In today's economy unfortunately there is not often the same opportunity for young engineers to have this level of support from their employer.

Did I gain the knowledge to carry out these responsibilities in University, certainly not?

This does illustrate the obvious fact that an undergrad degree simply provides the student hopefully with the tools to survive in the profession. As in my case it is the “learning” that

occurs as a result of the demands of their employment that is critical for their success. In my view if we can foster the ability to learn as these graduates deal with the need to solve problems that should be the fundamental role of a University education.

Considering the enormous variety of fields that chemical engineering graduates find themselves in, the requirements for a chemical engineer in the patent field for example or the medical field the science and technical requirements are obviously quite different and just as essential. It is obvious that no University degree can provide an individual with the skills and knowledge required to deal with one's unique experience. This being the case what is the role of Engineering Education?

## **Engineering Education**

I had always had an interest in education since I found that I quite often was expected to "educate" new employees about various aspects of the petrochemical or refining industries. I have over the years developed a profound interest in how people "learn", and what is the most effective way to educate our young men and women who wish to become professional engineers.

On the basis of my professional experience and my years as an adjunct associate professor at Queen's it is interesting to look at how engineering education has changed, and the impact these changes have had on undergraduate education. The Engineering Literature over the years that I have been involved has had many articles calling for change. I personally found the definition of required change by John Prados (1991-92) ABET (1) president most significant.

*A new engineering education paradigm is required built around active, project-based learning, horizontal and vertical integration of subject matter, the introduction of mathematical and scientific concepts in the context of application, close interaction with industry, broad use of information technology, and faculty devoted to developing emerging professionals as mentors and coaches rather than all-knowing dispensers of information (1)*

I often refer to Goldberg's paper of April 1996 (2) which delineated the necessity for change in Engineering Education, his reasons for the necessity for change and his suggestions to achieve change. Fifteen years later I hear the same issues being discussed. The first issue is the conflict between research and "teaching". I personally dislike the term "teaching", a system that dates at least as far back as Aristotle, where the knowledge expert (the teacher) tells the novice (the student) about his discipline. Accepting the fact that there are different learning styles this model is generally accepted as not being universally effective.

Having spent several years in my career in research establishments, I certainly recognize the value of research. My concern is an issue of balance.

The other issue is a Myth as suggested by Goldberg where basic research is the overarching mission of an engineering college/University. This myth originated from the misguided view that the success of the Allies in the Second World War was mainly due to the efforts of scientists, in particular physicists rather than engineers. When the Russians launched Sputnik this certainly had a further effect of promoting science to the relative exclusion of engineering practice in the engineering curricula. In an extreme form basic research is a "virtue" as compared to the applied.

There is an excellent paper by Bruce Seeley (3) that gives an overall history of Engineering Education from 1900-1965. It is quite clear from this history that although the Second World War had a great impact on the evolution of Engineering Education to a science based curriculum this move had begun years before by the entry of several notable European trained engineers to the U.S. system.

The capstone design course is another issue of importance. DESIGN is the quintessential aspect of the professional engineer. Although few of our graduates will have the opportunity to

be involved in a major design, the design process is fundamental to many aspects of engineering. Chemical process design depends to a great extent on project planning, economics, regulatory compliance and fundamentally Process Safety and Loss issues. A capstone design course is usually quite labour intensive for faculty and is best conducted by someone with extensive experience in the design field.

This assessment of how change over the years has resulted in curricula that in my view is unbalanced, where fundamental science seems to have crowded out the issues of Professional Skills.

This then brings up the question of increasing competition in the field of Engineering Education.

There is a question that I often ask myself. “What are we doing that can’t be done in a “trade school”. In Ontario the Community Colleges are thriving and now enrol more students than the Universities. The Community College system has moved significantly away from its original focus of the traditional “trade school”. Some of our grads upon getting their bachelor’s degree and finding it a difficult job market take one or more practical courses at a Community College, since they find it does enhance their resume. Where do we draw the line between material that is taught at a University and that taught at a Community college? Engineering is a profession often described as applied science, but that still doesn’t answer the question. I recently reviewed a research display at a large community college and I couldn’t tell the difference between the thesis work of the students and the thesis work of our students.

Engineering has been defined as a profession that works at the margins of a number of pure disciplines, *a gloriously marginal profession*. What is it that we in the colleges and Universities offer that is unique? The college system is based primarily of the potential areas for employment of their graduates. It is a quite nimble system where courses can be instituted or dropped depending on the potential for graduates to find employment.

I would like to think that “Professional Skills” is the area where a University degree should offer a significant difference. There is no question that a practising professional engineer today is likely to be confronted with ethical considerations on more than one occasion. One area which has changed dramatically in the time since I graduated and today that being Health Safety, the Environment, and the need to comply with a rapidly increasing number of regulations many of which overlap between municipal, provincial and federal. There is a rediscovery of “Green Engineering” which in many respects seems to infer that plants designed in the 50’s and 60’s are inherently unsafe. This is certainly not the case.

As an example of a profound change that has affected the practice of Chemical Engineering is the issue of “chemicals” in the environment. It isn’t all that long ago where DuPont had a slogan “Better Living through Chemicals” As a result of prominent disasters, such as Flixborough in the UK, Sevesto in Italy and Bhopal in India the general public began to take a considerably negative notice of “chemicals:” in the Environment. Rachael Carson’s well known book “The Silent Spring” precipitated a host of misguided developments which had major serious effects such as the vast number of unnecessary deaths in Africa as a result of the banning of DDT. . The petroleum and petrochemical Industries have been fundamentally affected as a result of these issues which have resulted in a generally negative view by the public at large and a considerable increase in regulations.

This then brings me around to a discussion of how we at Queen’s University attempt to approach the issue of “Professional Skills”, our Technology Engineering and Management TEAM program (4). Queen’s certainly is not unique as there are many other approaches at other schools particularly in the U.S.



TEAM is a fourth year project course open to the various branches of Engineering, Business Students, Law Students and other faculties who wish to participate. Multi-disciplinary teams select an industrial project of their choice and spend their final year working on this project for a fee-paying client. While most projects are in North America we have had projects in Europe and Asia. We have found that as long as the client has financial commitment they tend to be more involved with the student teams. This program began in 1994 as a joint effort between the School of Business and Chemical Engineering.

The projects are very diverse in nature from pharmaceuticals to essentially business management exercises. All teams have a professional advisor usually from outside the university, and there are regular meetings with the TEAM coordinator to make sure that the projects are on track. Of course Project Management is a major part of the program but there can be significant environmental aspects as well. One project one year carried out on behalf of the Canadian Chemical Producers Association comparing Canadian and International regulations resulted in a final report that was given an ISBN number as a reference document for members of the CCPA. This project was a joint effort of law students and engineering students.

Process Safety Management is an issue that often comes up when dealing with chemical or refining processes. This is a subject that we consider almost obligatory for those who intend to enter the hydrocarbon processing field. Of course we must recognize that many of our students will never practice engineering, either using the degree as a starting point for a study of medicine or law for example, or as a background for a career in finance. In this respect Chemical Engineering tends to focus much more on process rather than product which lends itself to many fields other than engineering. To some degree the projects we have in TEAM demonstrate this, most of them requiring an in-depth analysis of the financial aspects of the project.

There is however one fundamental aspect of learning that we are trying to achieve here. Student teams are faced with a problem that in most instances is something for which they have no background. “Just-in-time learning is an essential requirement for all teams, something that they are likely to be faced with most frequently in their careers. They are in a diverse team, often with people from different faculties. One Commerce student who has become very successful said that TEAM was the most valuable experience at Queen’s as it gave him a “Bean Counter” an understanding of how “Propeller-Heads” engineers thought. They have to develop a project plan and keep to it, not simply to satisfy an instructor but a fee paying client. While it is impossible to introduce specific learning expectations, all students will be exposed to communications problems, within their group as well as with the client. There often are ethical issues involved, for example is a client using a team of students to gain information about a competitor. Environmental issues seem to be part of many of the projects. There is usually a fair amount of travel involved and the students must budget and control their expenses. Having to coordinate TEAM meetings when there are a diverse group of students from different faculties in a team is always a challenge.

We insist that the students make a professional presentation of their results at the office of the client wherever possible. We recognize that traditional individual assessment approaches are not possible for this program however we do use peer assessments and on occasions individual students have been assessed a zero as a result of these (If you want a mark in TEAM, same time same place next year). What we try to do is to emphasize that we have a high expectation of performance from all teams. If they achieve this they essentially get a “pass” an 85 %. The basis of this is that there will be no marks in their career. The other faculties involved accept this mark for their students. On one occasion we had community college students’ work on a team with mixed success. We strongly recommend that we reintroduce this concept in the

future. Engineers seldom if ever work in isolation, they work in teams, which often include Community College Graduates.

### **CONCLUSIONS**

There appears to be an on-going conflict between Research and “Teaching” in Canadian Universities. One’s career is predicated to a major extent on one’s research rather than their “teaching” performance. I am sure that this is generally the case in most Universities

There is no question that grounding in fundamentals is essential for our graduates. A complete Capstone Design exercise should be essential as well. Employers currently place a lot of emphasis on “soft skills” which are basically teamwork, and communication skills. Professional Practice Skills should be a large part of an undergrad education, for that matter they should also be introduced at a graduate level.

Our students are entering an industrial environment that is increasingly team-oriented, multidisciplinary teams, where they will be expected to solve problems.

A large body of research and experience shows that “active” learning is in general significantly more effective than the traditional “passive” learning in a lecture environment.

All of this presents a major conundrum. For the benefit of our students and the profession we should introduce more problem based learning, we should spend a great deal more time on “Professional Practice Skills” and we should try to minimize lectures. Unfortunately with class sizes of well above 100 students this simply is not an option. In a four year undergraduate program there simply isn’t enough time to cover all this properly. A five year program would be an improvement but the question is who would pay for this?

Fundamentally what we must strive for is to develop an ability of our students to attack unfamiliar problems and “learn” what is necessary to solve these problems. In industrial practice this is of much greater validity than vector calculus. This not to say that there may be a problem that requires advanced mathematics. And unquestionably many of our graduates will have to rely on science and mathematics in their careers. It is recognized that in today’s very connected world, it is usually not much of a problem to find information concerning issues of fundamentals without having to retain this knowledge in ones head.

The TEAM program attempts to do this by placing a multi-disciplinary team in the position of working for a fee-paying industrial client on a real world problem. Hopefully we can introduce some of the issues mentioned previously.

Judging by the popularity of the program and feedback from students who have participated we seem to have achieved this. It is interesting that in many instances the law students are the most enthusiastic.

A recent talk on TED talks discussed the growing popularity of Studio schools in the UK where student teams work on problems supplied by industry and business. This has been reported to be very successful. The point of this is that TEAM while unique in Canadian Universities to the best of our knowledge is certainly not the only approach to providing effective active learning. Harvey Mudd College in California has a very similar program.

TEAM is labour intensive and expensive. There is a great deal of travel involved much of which is long distance (Kingston to Calgary for example). Although the client fee covers a significant amount of this, TEAM has been supported for several years by a major grant from Shell.

### **REFERENCES**

- (1) Prados, J.W., "The Editors's Page: Engineering Criteria 2000-A Change Agent for Engineering Education," *Journal of Engineering Education*, 1997, pp69-70
- (2) Goldberg D.E., "Change in Engineering Education: One Myth, Two Scenarios, and Three Foci" *Journal of Engineering Education*, 1996, pp107-116
- (3) Seely B.E., "The Other Re-engineering of Engineering Education, 1900-1965" *Journal of Engineering Education*, 1999 pp285-294
- (4) <http://team.appsci.queensu.ca/>

## **SECTION 4**

**Engineering Education for the 21st Century-Balancing Engineering Science,  
Information Technology and Multidisciplinary Studies**

Kenneth W Jackson Ph.D., P.E. Southern Polytechnic State University

KENNETH WADE JACKSON

Dr. Ken Jackson holds a Ph.D. in ME, an MSME, MSIE-OR, BSME and is a Registered Professional Engineer. Prior to academia, he worked 31 years for AT&T, including 15 years at the Bell Telephone Laboratories on the design of fiber optic products. He also worked on the SAFEGUARD ABM System, and in product development and manufacturing. Dr. Jackson has authored 17 patents and 24 technical papers, and is a member of the ASME, ASQ, and ASA.

# Engineering Education for the 21<sup>st</sup> Century-Balancing Engineering Science, Information Technology and Multidisciplinary Studies

*Kenneth W Jackson Ph.D., P.E. Southern Polytechnic State University*

## Abstract

**Educating engineers for success in the 21<sup>st</sup> century workforce will require continually adapting the curriculum subject matter to reflect relevancies to public and corporate stakeholders. The planet's population is growing to unprecedented levels and making vital resources even scarcer. For decades after World War II engineering education tended to focus primarily on engineering science or physics using reductionist analytics. The less mathematical sciences of design, synthesis, systems, organization and planning became relatively minor parts of an undergraduate's studies. In the latter 20<sup>th</sup> century, the end of the cold war, the IT revolution and new understandings about the affordability and benefits of manned space travel tended to redirect earlier 20<sup>th</sup> century research. Engineering research continues to increase in corporate laboratories where the focus is on developing tangible products and services to satisfy the more immediate needs of humankind. Research grants to universities are not likely to command as great of proportion of national income in the 21<sup>st</sup> century as in earlier years. Future engineers must be able to work on a variety of pressing and difficult problems such as innovation subject to severe resource constraints. Moreover, attracting students to engineering will require an inspiring vision of the prospect for exciting engineering work such as the space program provided. The nation's new problems will require undergraduate engineers to acquire complementary skills and perspectives of multiple disciplines that more explicitly recognize the practical importance of the human element *and* technical innovation. Engineers in the 21<sup>st</sup> century will face unprecedented global change and rate of change in technology, economics and social institutions. To meet these challenges, recently referred to by the NAE as a *gathering storm*, engineering education will need to embed more technology and *soft* skills into traditional science-based engineering courses *without* reducing practical STEM content and rigor. Engineering faculty will need also to create and develop challenging new multidisciplinary courses that embed engineering science and technology within the context of experiential learning and practice. This paper examines the need for and ways to integrate engineering science, information technology and multidisciplinary work. We describe how we have used the University's Honors Program to provide students with experiential learning in integrating the knowledge and perspectives of their discipline with that of others in the design and development of a virtual product.**

## Introduction

In recent years many leaders from corporate America and academia alike have called for undergraduate engineering curriculums that integrate more multidisciplinary experiential learning within the context of real world situations. Such innovation in engineering education while maintaining its traditional rigor presents many challenges. These interrelated challenges include the following: (1) Critical STEM competencies and professional licensing capability must be imparted in a traditional four year program of study. (2) Lecture based courses are more efficient. (3) Many faculty perceive the analytical, math-intensive courses in engineering science to have higher prestige. (4) Individual learning assessment in experiential, project-based courses is less objective and the supporting assessment pedagogies for engineers are not well developed. (5) Fewer faculty have experience and training in teaching multidisciplinary design courses. (6) The last two years of engineering studies tend to be strongly compartmentalized within the discipline specific departments. Notwithstanding these and other challenges, the nation's need for competitive and sustainable innovation in an era of unprecedented resource scarcity justifies a more concerted effort among engineering faculty to develop and teach multidisciplinary engineering courses involving experiential learning. The courses need to challenge students to think critically and deeply about complex and ill-structured problems. Students need to learn the meaning and importance of framing for solution facilitation; i.e. to ask the right questions. Lastly, students need to learn how to work outside their comfort zone in situations where they must maintain the patience, initiative and focus necessary for practical and timely solutions. For the 21<sup>st</sup> century, America needs engineers who better understand the dynamics and imperatives of innovation and wealth creation. Future engineers need to be able to analyze and design complex systems that are sustainable and can compete in the global economy. Significantly, engineering schools themselves must innovate and engineer a delicate balance among traditional engineering science, information technology and multidisciplinary studies.

## Background

For the last 150 years American engineers have been crucial to the nation's security and prosperity. Inventiveness, ingenuity and innovation have been the historical hallmarks of the American engineer. However, several authors and leaders have seen a slow drift in engineering education away from its traditional moorings in design, inventiveness and innovation [Simon, 1996, Tribus, 1999]. Specifically, there has been concern about the increasing emphasis on mathematical analysis and abstractions to the detriment of concrete design, synthesis and the multidisciplinary perspectives needed in practice. This concern is not a totally new concern, but the intensity of the concern seems to have increased substantially. The reasons thought to be responsible for the evolution of engineering towards evermore mathematically-based science involve complex interactions between engineering research and the general culture of research. Other contributing factors include the 1955 Grinter Report, the cold war, the implicit criteria for government grants and the exponential growth of computing and information technologies [Engineering Education Reprint, 1955]. Herbert A. Simon noted that for several decades following WWII that the engineering schools increasingly became schools of physics and mathematics. Topics were selected from the natural sciences and those associated

with the “science of the artificial” or design were marginalized or subsumed under analysis. Simon made a cogent point that the basic cause was cultural as the engineering schools “hankered after academic respectability” [Simon, 1996]. The reason may have also been financial. With the advent of the U.S. space program really big budget research emerged. Grant proposals that included sophisticated mathematical analysis had more scientific cache and attracted a larger share of the government grants. The alternative for engineering schools was to look like the “trade schools” of yesteryear and lose potential funding. Initially, advances in computing technology reinforced the trend towards increased analysis because Ph.D.s could now solve many of those complicated partial differential equations. Ultimately, computing and communications technologies were applied to the problems of design, yet commercial interests and proprietary file formats impede progress even to this day [Prawel, 2011].

The important discipline of systems engineering emerged as defense and space systems of unprecedented complexity needed to be affordable, safe, reliable and delivered on time [BSTJ, 1962]. Systems engineering, as practiced, was strongly inter/multidisciplinary and better assured the timely delivery of a system with unified purpose. In the 1980s, leaders of the American quality revolution recognized that multidisciplinary concurrent engineering teams were needed to solve the quality problems of both product design and manufacturing. One such team of co-located technical professionals at the author’s company, Bell Telephone Laboratories, worked together for more than 20 years to help realized the nation’s high speed optical communications infrastructure. The development teams were collocated to foster the face-to-face shared communication and synergistic perspectives required for innovation. This approach was deemed necessary as graduate engineers did not have the needed perspectives across multiple disciplines. Today similar diverse teams are used to design, develop, manufacture and deploy complex products and systems. Notwithstanding decades-long ubiquitous use of systems engineering and cross functional team-based engineering of products in industry, formal education in the systems approach and how to work effectively in the cross-functional team environment has not found its way into the undergraduate curriculum. Lastly, the end of the cold war coupled with a rise in the global economy has lead to incipient commoditization of some engineering and technical skills and intense competition.



## The Role of Engineering Science

Engineering science, underpinned by mathematics, will remain a fundamental and dominant part of the engineer's education. The 20<sup>th</sup> century has been rightly called the century of science because science and its offspring, engineering and technology, fueled the engines of economic growth and progress from beginning to end.

Unfortunately, it also fueled the engines of war, pollution, scarcity and ultimately 911. Relativity, the quantum theory, atomic energy, the transistor, the double helix, the computer, the laser and the internet; these scientific breakthroughs literally transformed everyday life and many professions. Arguably, all became commercial realities by a science-based engineering education. Engineering educators have served the needs of the nation admirably for many years and the initial the focus on engineering sciences was salutary. For undergraduates, a less salutary and unintended consequence was the gradual marginalization of general design, planning and organizational skills as well as hands-on experimentation and interpersonal skills. Some universities developed engineering technology programs in response to help address expressed needs of industry and many now have ABET accreditation of programs' rigor.

Lewontin has pointed out that all sciences tend to be driven by dominant metaphors, which are used to connect and direct different areas and modes of inquiry [Lewontin, 1963]. Many years of textbook problem solving is the paradigm of education in the traditional sciences. Engineering education seems also to have evolved around the metaphor of *problem solving*. Textbook problem solving for engineers, although a vital part of teaching and learning, strongly resemble Kuhn's concept of *puzzle solving* of normal science. Kuhn's famous paradigm essay points out that the method of normal science and perhaps normal engineering focuses on *puzzle solving* [Kuhn, 1962]. Problems in engineering textbooks are a bit like puzzles. That is, these problems are *designed* to be solved because typically all the pieces will fit together in only one way. Moreover, if we have the final picture (like the required answer) any remaining pieces of the puzzle can usually be made to neatly fall into place, much like a jigsaw or crossword puzzle. If one could solve these puzzles they were said to be *ingenious*. But engineering problem solving in practice differs from textbook problem solving because real world problems are not very puzzle-like. They are not pre-designed to be solved; if anything the very opposite is the case. The few pieces one may have do not fit together so well, many pieces may be optional and there is no final picture in the mind's eye to fill in the blanks. The practicing engineer not infrequently has to construct new pieces on the fly to achieve a fit with the rest of the pieces. And in today's complex systems, engineers' must often design an interface. Most quality problems and product failures occur at interfaces and few engineering students get training in interface engineering. Thus, our real world problems are said to be ill-structured and open-ended. The foregoing analogy between the engineer's textbook problems and puzzles is not complete however. Indeed, there is an undeniable benefit of textbook problem solving and it correlates well to an engineer's on-the-job technical, if not managerial, successes. Textbook problem solving can serve as a surrogate predictor of crucial elements of technical success—tenacity, perseverance, and extended focus on a goal, even in the face of failure, until one wrests a solution from nature. In the world of the design engineer, an on-paper design has an element in common with an end-of-chapter puzzle. It most always has

a solution in theory. The practicing engineer's "anomalies" first emerge when one first tries to make a physical prototype. The anomalies appear in even greater number when one tries to mass produce the design. The harshest anomaly occurs in the market when customers try to use the product or service and the supplier must turn a profit. Only an engineer's *ingenuity* can minimize and overcome these real world anomalies.

It is the author's opinion that, in its original sense, the engineer's *ingenuity* developed primarily through extensive *laboratory* experience; much like a physician or surgeon's *ingenuity* is developed in a clinical setting. In both instances one must deal with the holistic situation and not abstractions. The model of medical education for the physician is designed to be holistic early in medical school. Their first course is gross anatomy. Clinically based medical education is far more effective, if not very efficient, as one can surmise from the cost of medical school. Even though engineering educators do not have eight year programs, except for Ph.D. s, engineering education might still profit some from the context of medical education, which introduces clinical experiential learning early and continues throughout the program and into residency.

The abstractions and reductive nature of teaching engineering science are highly efficient in terms of the metrics of cost and time and are reasonably predictive of success in practice. In terms of its growing specialization and depth of focus on engineering science, engineering education may have become less effective for today's work environment and concerns about this have been growing since the mid to late 1970's. Engineering educators will not know if they can better satisfy the nation's current needs without some level of structured innovation in engineering education. A directed evolution of engineering science in the undergraduate experience seems to be more appropriate than a revolution from the ground up. There seems to be no compelling need to reduce engineers' education in the fundamentals of engineering science. However, perhaps we could teach more than just the textbook puzzle-problems in traditional engineering science courses. Creating problems that start from a local physical embodiment could provide a more holistic situation and might be useful for better engaging students with physical reality. Secondly, increasing laboratory work might also be useful. Unfortunately, there seems to be a lower value placed on teaching laboratory courses as evidenced by these courses being frequently assigned to graduate assistants. Having experienced both analytical and experimental work, there is no doubt in the author's mind that analytical and deductive engineering courses take less time to teach and are easier to assess than their iterative and inductive counterparts. Those who have worked in engineering laboratories know well how difficult it can be to get stubborn observations to cooperate and agree reasonably well with our theoretical abstractions. Lastly, it might not be required to drill down quite as deeply for undergraduates.

## The Role of Information Technology

**As a result of the information revolution, information technology will play an essential and ever changing role in the education of engineers. Characterizing the role of IT, even for the traditional engineering disciplines, is difficult because not only is it continually evolving, but also because its use is highly variable both among the traditional disciplines and even within a single discipline. Notwithstanding these difficulties, the various engineering disciplines must try to leverage and balance the role of IT as it relates to their fundamental mission and to engineering science and multidisciplinary studies. Information technology enters an engineer's education in three ways. First, IT in the form of software and computers is used as a calculation and data visualization tool. Secondly, through global, mobile, broadband communications, IT has increased the scope and scale of knowledge management, data acquisition and communication almost beyond the imagination. Lastly, through distance learning, IT is directly influencing how teachers teach, how students learn, and how well teachers can assess that learning.**

**Through an ever growing number of commercial and open source software packages, IT provides calculation tools for solving textbook problems, and for modeling and simulation. Contemporary desktop software has bewildering functionalities. However, just because software enables us to do things in a course that formerly we could not does not mean that we should. One should be reminded that the engineers who helped put man on the moon were educated with slide rules. In fact, a slide rule was taken on Apollo 13 to the moon in 1970 [Smithsonian Air and Space Museum]. Learning to use complex commercial software can easily become time wasted, like the waste of overproduction in manufacturing that the Japanese so astutely recognized and avoided. Moreover, the visible time wasted in teaching the use of such software in the classroom may be the tip of the iceberg compared to the mouse work that engages students outside the classroom. The lost opportunity for deep thinking and personal dialog, like lost sales due to poor quality, is unknown and unknowable; but, it is not likely trivial and, it must be managed. Learning specialized software can also distract young minds from the extended focus and practice required to internalize important powerful physical concepts that students will use at some point in their career.**

**The author's experience is that many managers tend to distrust complex computer calculations that are not backed up with laboratory data. Simple models that robustly describe complex data and that have a mechanistic foundation and intuitive appeal are best for communicating with managers. Ironically, experience indicates that beyond a point the less complex models even tend to *predict* new complex data more accurately; and, the messier the data the better simple models perform. Simple models tend to be highly efficient and can provide up to an order of magnitude more economic value than just experimental data [Gauch, 1993]. Over reliance on deduction from theory or inductive empiricism can result in ambiguous, if not inaccurate, inference, representation and interpretation of results [Jackson, 2010]. Moreover, accurate physical property data and other parameters required for prediction or simulation are often the largest source of error.**

**It may well be that efficient and effective use of IT for communications and knowledge management will prove to be the most important for innovation. IT will enable engineers to communicate literally anywhere and anytime through multiple**

media of voice, text and video and in ways we have yet to imagine. The innovation process is no stronger than its weakest link and that link is often the last link- the introduction of a new product or service to a large market of eager and able buyers. Ideally, the use of IT as a broad knowledge management and communication tool would be covered in undergraduate core classes in communications. Yet there is much room for teaching engineering students more about the emerging field of knowledge management. Examples include conducting a patent search, finding accurate and reliable physical property data, identifying and sourcing high quality components and equipment, and analyzing customer, supplier, and competitor information are all important.

The direct influence of IT on engineering education in the form of distance learning is becoming pervasive, but its use remains controversial and cumbersome for courses that require real time problem solving involving the physical sciences and mathematics. The use of IT to enable distance learning of engineering subjects has real advantages and disadvantages and one rarely hears well-reasoned balanced discourse that is free from bias. Commercial vendors clearly and understandably have a positive bias about their products suitability for use in any field of study. Web enabled education increases students' access to a college education and this makes it popular with legislators who also have been told of its *future* potential for cost reduction. Administrators see the potential for cost reduction as positive because they must address the concerns of legislators and the continually increasing cost per degree granted. Much of the real cost of IT for online education with time can become subsumed and hidden under general IT costs and it will be difficult to untangle for accurate estimation and management. A thorough activity based cost study might be enlightening. Administrators must also worry about losing students to other institutions, as the boundary between the traditional brick and mortar university and the rest of society becomes more diffuse.

Faculty tend to have a conservative bias against change in proven pedagogies to avoid any possibility of risk that might impair the quality of their students' education. Small impairments to the education of the population of new engineers can have serious consequences for a nation that must compete globally. There are also less altruistic reasons for conservatism because of the large amount of time it takes to prepare and maintain online course content relative to that of traditional classes. There is also time wasted in learning and relearning the stream of new course management tools, which promise to solve the limitations of existing course management systems. Another waste of time involves the serial nature of the interface for communicating with students about their assignments which is not experienced in a traditional classroom environment. Many, if not most, engineering faculty do not advocate the use of "PowerPoints" for teaching engineering analysis as it "chops-up" the learning experience into discontinuous frames, which inhibit students' complete visualization of the reasoning process. Moreover, pre-prepared solutions tend to give students a false impression of the difficulty of the problem solving process. Tablet PCs can be used for real time problem solving in distance learning classes, but the size of the frame presented to the students is still considerably less than that of a traditional whiteboard.

Course management system vendors have not responded as well to the needs of engineering, math and science faculty as seems to be technologically possible. Part of

the reason may be that vendors committed early on to a restricted course management system architecture, which may have been designed largely for asynchronous courses that use primarily text-based activities. In contrast, engineering students use traditional pencil and paper analyses that integrate sketches and equations with a little handwritten text. The Tablet PC helps solve this integration problem, but software is needed that better integrates with streaming applications for synchronous online delivery. Another reason for restricted functionality may be that the intellectual property rights have become highly fragmented among the various vendors and no single vendor can offer a complete system without infringing on the rights of a competitor. The multiple software packages that must be purchased to achieve complete functionality are expensive, both in terms of the first cost and the time to use and to maintain them. Another concern is the scale and scope problem, which involves the important distinction between a mere existence proof for a design and a design that is suitable for routine and profitable “mass production”. Course designs that can be made to work once or once every 2 years because of extraordinary teacher effort may be unsustainable for offering every semester with multiple sections per semester. Lastly, will industry leaders value engineering programs that are taught predominantly online the same as they do for traditional engineering degrees? One can expect that over time most of these issues will be resolved.

In summary, IT will form an increasing and important part of the engineer’s education in the 21<sup>st</sup> century. The author believes that specialized commercial software packages will have the most limited role in engineering education. Distance learning will have an increasing and more important role, especially for access and for teaching graduate subjects to adult learners. The use of IT for knowledge management will grow in importance. The weakness in online teaching of engineering subjects is the serial human interface and the small screen size of the laptop. As information technology and its interface to humans improve and mature, IT can become a valuable part of engineering education. The limitations of distance learning are more likely to be overcome by the use of new and better hardware such as pen-based PCs and smarter whiteboards than by software alone. Engineering educators must continually and rigorously critique and adapt IT as it evolves so that it adds value to the students’ education. IT should be demonstrated to enhance long term learning of engineering concepts, principles and problem solving skills. Ultimately, as for products in industry, the effectiveness of information technology for engineering education will determine the extent to which it will be used. America should continually conduct disinterested benchmark studies of our use of IT in engineering educations with other highly developed nations.

## The Role of Multidisciplinary Studies

**In the late 1980s, businesses noted that most value was created through a few cross-functional processes and not through their functional organizations. Thus, value was created through cross disciplinary or multidisciplinary processes. These value generating processes, for example, product innovation needed to be managed as a single entity through permanent multidisciplinary teams that were an orthogonal analog of the organization functional departments and disciplines. Significantly, companies discovered that the knowledge created by teams of interacting members can be greater than that which could be created by the individual members working alone. Moreover, the concurrent team approach helped to avoid local optimization. The new product development teams typically comprised engineers, IT specialists, patent attorneys, chemists, material scientists, marketing, finance and accounting, manufacturing, process analysts and lastly, customers, suppliers and other outside stakeholders. It became necessary for engineers to understand the paradigms, metaphors, perspectives, terminology and most importantly, the interfaces among the various disciplines with which they were required to integrate their technical work. Engineers needed new interpersonal, communication and negotiation skills to work in the new team environment and many companies provided that training. Engineers of the future need to experience working in a team-based environment at the university and not through many years of on the job osmosis. They also need to learn basic knowledge about the other disciplines with whom they will likely be required to work. Moreover, when the various disciplines are distributed over the globe, engineers must also learn how to function on teams in a multi-cultural context. Engineers, perhaps more than other professionals, need to improve their interpersonal skills. This will require more direct face-to-face interaction and collaboration with other disciplines than engineering students have traditionally had an opportunity to experience.**

**The call for increasing engineering students' exposure to multidisciplinary studies should not be misinterpreted to mean changing the fundamental knowledge that gives engineering and engineering technology their identity. Engineering and engineering technology will remain being defined by grounding students in mechanics, materials, thermal sciences and transport phenomena, electromagnetics, and in experimentation and laboratory technique. In addition, more multidisciplinary studies should be taken by students in all of the engineering disciplines. There is nothing intrinsic which make graduates in any one of the engineering disciplines better suited for interacting with customers, the general public or other cultures. The same holds true for managerial aptitude, whether in consulting, civil work, manufacturing or research and development.**

The Honors Program for Teaching Students to work on Multidisciplinary Teams

**As a first step, we have used our universities' Honors Program to teach students how to work better on multidisciplinary teams in a multicultural context. The vehicle is an honors course, titled "Bringing a New Product to Market from Concept to Launch" [Jackson and Reichert, 2010]. In this course students design, organize write, present and defend a launch plan for a virtual product. The virtual product is selected by the professor. Students are required to give brief project updates, maintain a journal, present their contribution and write a final report. These and peer evaluations count about 65 percent of their grade. Students learn the basic body of knowledge of the disciplines used in new product design and development. Quizzes and homework assignments on this material count about 35 percent of the final grade. Homework assignments are used to elaborate textbook principles and are designed to relate directly to students' virtual design project. The problem assigned may be one aspect of a problem that the university or community faces or expects to face, or it may involve both technology and intergenerational issues. Typical problems have included a cell phone for seniors, and a classroom environment to support pen-based Tablet PCs. Students learn through experience that although their own specialty may be necessary for success it is not sufficient.**

**Students are given extended experience planning, organizing, communicating, collaborating, integrating and coordinating their work because these are important navigation and competitive skills for students entering the workforce. Honor students tend to exercise a higher level of self-management and organizational skills and are often better prepared for the systems level thinking needed to attack ill-structured problems. Although they include those who are best prepared, they ironically often include students who can benefit most from experience in solving problems of the types encountered in the workplace. Honor students tend initially to discount the value of systems thinking, planning and organizing as just much "common sense", perhaps because it does not involve the relatively fast solving of the analytical puzzles at which they have traditionally excelled.**

**The course differs from capstone design courses in that the student teams come from diverse disciplines and cultures and the problems are more open ended. Yet these small differences can present unique challenges for students and professors alike. We try and balance the team composition across technical and nontechnical disciplines, gender and national origin. The professor teaches coaches and mentors. Instructors with experience in practice and in teaching are well suited for developing and teaching multidisciplinary design courses. Although the course has been received well by students, more work remains, including how to best design a course more suited to the general student population.**

## Conclusion

**In the 20<sup>th</sup> century science became *democratized* and many technological disciplines including engineering appended the modifier, “science”, to better describe themselves. Many engineering programs continually increased their focus on teaching engineering science and over time other important skills needed for workplace success and innovation became marginalized. Engineering includes science as its foundation, but it is much more. Engineering is a creative profession that is eminently practical and essential for innovation to solve contemporary problems and to promote societal progress. In the 21<sup>st</sup> century, the engineer’s education will need to be extended beyond the traditional core and fundamentals of engineering science in order to help solve America’s need for more innovation. The education of the engineer in the world of tomorrow will need to carefully balance engineering science, information technology and multidisciplinary studies. This will include how to use information technology more effectively to learn, and to manage knowledge. Engineers will need more exposure to learning experiences involving open ended problems requiring collaboration of diverse multidisciplinary teams. Addressing America’s innovation concerns will also require engineering schools to innovate. At SPSU, we have used an honors course focused on bringing a new product to market to introduce students to working on diverse multidisciplinary teams and to learn the body of knowledge of new product design and development. The innovations that are being called for in engineering education may prove to be *disruptive* if only those universities who start new engineering schools are those who recognize and act on the challenges and the opportunities.**

## REFERENCES

1. Brown, Alan S. “The Creative Impulse”. *Mechanical Engineering*, September 2007, pp. 24-29.
2. Capallari, J. O. Jr., Editor. “Where on the Moon? An Apollo Systems Engineering Problem,” *The Bell System Technical Journal*, Vol. 51, No. 5, May-June 1972, pp.955-1125.
3. Gauch, H.G., Prediction, Parsimony and Noise, *American Scientist*, Vol. 81, 1993, pp. 468-470.
4. Jackson, Kenneth W. and M. Tabaddor. “Correlation Modeling of Complex Data – Physics, Statistics and Heuristics”, *International Journal of Data Analysis Techniques and Strategies*, Vol. 2, No. 4, 2010, pp. 336-355.
5. Jonassen, David, Johannes Stroebel, and Chwee Beng Lee. “Everyday Problem Solving in Engineering: Lessons for Engineering Educators”. *Journal of Eng. Edu.*, Vol.95, No.2, pp. 2006, 139-151.
6. Kuhn, Thomas S. *The Structure of Scientific Revolutions*, University of Chicago Press, pp 35-42, 1962.
7. Lewontin, R. C. “Models, Mathematics, and Metaphors.” *Synthese*, 15 (1963), pp. 222-44.
8. Prawel, David. “Lost in Translation”, *Mechanical Engineering*, Vol. 133, No 9, September 2011, pp.44-47.



9. Simon, Herbert A. *The Sciences of the Artificial*, Third Edition. Cambridge, Mass. MIT Press: 1996, pp. 110-138.

**10. Smithsonian Air and Space Museum.**

<http://www.nasm.si.edu/collections/artifact.cfm?id=A19840160000>

**11. Summary of the Report on Evaluation of Engineering Education. Reprinted from *Journal of Engineering Education*, September, 1955. pp. 25-60.**

12. Tribus, Myron. "Will our Educational System be the Solution or the Problem?" *Total Quality Management*, Vol. 10, No 4&5, July 1999, pp. S745-S771.

## **Engineers on Wheels**

Kauser Jahan  
Professor, Civil and Environmental Engineering  
Rowan University  
Glassboro, NJ 08028

### **KAUSER JAHAN**

He is a Professor of Civil and Environmental Engineering at Rowan University. Dr. Jahan has been one of the cornerstones of the College of Engineering at Rowan University. She is a leader and innovator in the area of curriculum development and has become a nationally and internationally known expert in teaching. She won the NJ ASCE Educator of the year award in 2006, the AFT Gary Hunter Excellence in Mentoring Award, Rowan University 2007 and the ASEE Environmental Engineering Meritorious Service Award, 2007. She received the 2010 ASEE Sharon A. Keillor Award for Women in Engineering Education.

## **E<sub>w</sub>: ENGINEERS ON WHEELS**

### **Abstract:**

Engineers on Wheels (E<sub>w</sub>) is a mobile K-12 outreach program to promote engineering careers. Two vehicles with attractive wraps depicting various types of engineering disciplines are used for this program. One vehicle is also equipped with is equipped inside with a handful of stations with computers and display panels where the students can view demonstrations on engineering fundamentals and work on projects that demonstrate various engineering disciplines. The E<sub>w</sub> project is unique in that the program is delivered to school districts by engineering students and faculty. Engineering students develop and pilot the activities, lesson plans, and handouts. The program, has already reached out to numerous schools in the Southern New Jersey region with successful outcomes. Schools have limited money for educational field trips these days. Engineers on Wheels brings the 'field trip' to the students and also helps students learn about a possible career field.

### **Introduction:**

Science and engineering has been the base of the American economic growth for generations. We were leaders in the industrial revolution and we initiated the internet age. Today, these fields continue to have great potential for growing our economy and employing more Americans. Between 1983 and 2004 the percentage of the US workforce in science and engineering occupations almost doubled. However, recent data indicates that the USA is falling behind other countries in educating our youth in STEM fields. American students continue to score below international averages on math and science tests<sup>1</sup>. China, India and Japan both award more than 50% of their undergraduate degrees in science and engineering, while only 23% of US students receive these degrees<sup>2</sup>. The necessary first step is to improve science and math education in schools, because an educated workforce is the foundation for economic strength.

Engineering educators in the USA are thus looking at innovative ways of exposing K-12 educators and students to science and engineering at an early age. There is a growing realization among engineering faculty that a new vision for the education of engineers needs to evolve to keep this country at the forefront of technology. Science and engineering are essential partners in paving the way for America's future through *discovery, learning and innovation*<sup>3</sup>.

The nature of education is undergoing rapid metamorphosis as new technologies are developed. The future of quality education will include the ability to learn, comprehend, and interact with technology in a meaningful way<sup>4</sup>. While businesses and other organizations in the USA have embraced technology and made major progress in technology applications, schools despite their acquisition of millions of computers are still slow at using it. Countries in Europe and Asia have been far more successful in using technological advances in their classrooms to enhance literacy<sup>5, 8</sup>.

Enhanced engineering education in our K-12 classrooms can provide students at an earlier age with a more specific understanding of what a technical career entails. We must encourage teachers to assume a more active role not only in the implementation/delivery of the educational experience for the student, but also in the innovation and continuous improvement necessary for engineering education to meet these challenges.

### **Engineers on Wheels Program**

This Engineers on Wheels Program (E<sub>w</sub>) Program is a partnership between Rowan University's Colleges of Engineering and Education and has gained national attention<sup>9-14</sup>.

The program includes two vibrantly colored vans packed with activities to introduce various engineering disciplines to K-12 students in South Jersey and beyond, many of whom would otherwise not have a chance to learn about engineering — and the world of opportunities awaiting them in high-tech fields.

The Engineers on Wheels activities are designed to be a fun and interactive way for students to learn about engineering and its real world applications. Through exciting activities, such as a driving simulator, students learn that the fun they are having is directly linked to the types of work engineers are involved in. Every one of the activities has been designed to be educational for all age groups. For younger students the material is related to what is being learned currently in their physics or math classes. For high school age students, a similar method is used but additionally the program includes an explanation on how to major in engineering in college and what strengths would be needed to pursue a career along those lines.

Schools can schedule a visit by visiting the E<sub>w</sub> website<sup>15</sup>. This website is dedicated entirely to the Engineers on Wheels program and is geared towards young students. It is very user friendly and contains information about the program, engineering, activities the program runs, and pictures from previous visits. The website also contains a form for scheduling a visit. Below is a screenshot of the homepage of the website.

**Engineers on Wheels**  
A K-12 Outreach Program  
Brought to you by  
**Rowan University**  
Glassboro, New Jersey

Become a sponsor

**Engineers on Wheels**  
Sponsored by: **Edison**  
VENTURE FUND

The graphic features a brown bus with a yellow lower section and white wheels, driving on a blue road. The bus windows show a row of green trees. Above the bus, a blue cloud contains the text 'Become a sponsor'. To the left of the cloud is a row of seven circular icons, each containing a different image related to engineering or education. The background shows a blue sky with a sun and a green landscape with trees and a yellow ground line.

## Ew Vans

The Ew vans are “wrapped” with a dramatic engineering scene and one is equipped inside with a handful of stations with computers and display panels where the students can view demonstrations on engineering fundamentals and work on projects that demonstrate various engineering disciplines. Images of the vans are presented in Figures 1 and 2.



**Figure 1: Images of the Toyota Sienna Van used to transport students and supplies**



**Figure 2: Images of the Chevrolet Van (exterior)**



**Figure 3: Images of the Chevrolet Van (interior) used for interactives computer activities**

### **Activities**

Engineering students accompanied by faculty drive to school districts in these vans with attractive displays stating “ENGINEERS on WHEELS”. Students setup their activities around this van for their audience. Activities lending to the sustainability theme include samples from all engineering disciplines. Brochures and pamphlets are also available at these demonstrations. Hands on activities include drinking water treatment, lip-gloss processing, use of solar and wind power, bridge building, flight simulations, use of a human gyroscope, making clouds in a bottle, launching a soda bottle rocket etc.



. Some of the images of our activities are presented below:



The activities are typically very visual and of short duration (no more than 10-15 minutes). Materials used are also cost effective and readily available so that the schools can adopt the activity easily.

Activities are planned for both indoor and outdoor delivery. If the weather permits students are outside participating in the activities next to the parked vans. The location of the activities and van parking sites are planned ahead of the visit with the school staff. Materials needed for the program are contained in carts with wheels so that things can be moved and packed in a short time. Typically a science classroom works well for indoor activities.



The successful delivery of the program depends on preplanning with the school teacher, knowing the audience, the weather, the distance and duration of the delivery. Major organization for materials needed, student-faculty availability and van maintenance is also required.

### **Conclusions:**

Overall, Engineers on Wheels has a positive effect on students in the area surrounding Rowan University. The College of Engineering is already experiencing growth in their freshman classes. Hopefully, E<sub>w</sub> will interest and inspire the elementary and middle school students to

pursue careers in the mathematics, science and engineering fields. Also, it should provide other universities with inspiration to start their own engineering outreach programs.

### **Acknowledgement:**

The program was initiated with support from the Lawrenceville-based Edison Venture Fund and John Martinson, its managing partner. Lockheed Martin has also provided support for the purchase of the Toyota Sienna van.

### **References:**

1. <http://science.house.gov/press/PRArticle.aspx?NewsID=1215>
2. <http://www.nsf.gov>
3. <http://www.engineeringk12.org/Engineering in the K-12 Classroom.pdf>
4. <http://www.state.nj.us/education/>
5. Coiro, J. (2003). Reading comprehension on the Internet. Expanding our understanding of reading comprehension to encompass new literacies. *The Reading Teacher*, 56(5), 458 - 564.
6. Howes, E.V., Hamilton, G.W., and Zaskoda, D. (2003). Linking science and literature through technology. Thinking about interdisciplinary inquiry in middle school. *Journal of Adolescent & Adult Literacy*, 46(6), 494 - 504.
7. Smolin, L.I. & Lawless, K.A. (2003). Becoming literate in the technological age: New responsibilities and tools for teachers. *The Reading Teacher*, 56(6), 570 - 577.
8. <http://www.teach-nology.com/tutorials/techinclass/1/>
9. [www.rowan.edu/colleges/engineering/k-12/ew/](http://www.rowan.edu/colleges/engineering/k-12/ew/)
10. Jahan, K. and K. Sernak (2007) Engineering Clinics for Middle School Teachers, Proceedings of the WEPAN Annual Conference, Orlando, FL.
11. Jahan, K. and K. Sernak (2007) Engineering Clinics for Teachers, Proceedings of the ASEE Annual Conference, Honolulu, HI.
12. Jahan, K. (2007) Engineering Clinics for Teachers, Presentation at the Engineers of the Future Conference, Hoboken, NJ.
13. Jahan, K. (2011) Engineering Clinics for Teachers, Presentation at the NJEA Conference, NJIT, Newark, NJ.
14. Jahan, K. (2010) Engineers on Wheels, Proceedings of the ASEE Annual Conference, Vancouver, BC.
15. Jahan, K. (2012) A Mobile Van to Promote Environmental Engineering, Proceedings of the ASEE Annual Conference, San Antonio, Texas.

**Proposing a New Study in Non-Invasive Amperometric  
Glucose Sensing Technology through the NYCLSAMP  
Summer Fellowship Program**

Sunghoon Jang  
Department of Electrical & Telecommunications Engineering Technology  
New York City College of Technology of CUNY  
300 Jay Street  
Brooklyn, NY 11201

Peter Spellane  
Department of Chemistry  
New York City College of Technology of CUNY  
300 Jay Street  
Brooklyn, NY 11201

Mohammad Razani  
Department of Electrical & Telecommunications Engineering Technology  
New York City College of Technology of CUNY  
300 Jay Street  
Brooklyn, NY 11201

# Proposing a New Study in Non-Invasive Amperometric Glucose Sensing Technology through the NYCLSAMP Summer Fellowship Program

Sunghoon Jang+, Peter Spellane\*, and Mohammad Razani+  
+ Department of Electrical & Telecommunications Engineering Technology  
\* Department of Chemistry  
New York City College of Technology of CUNY  
300 Jay Street  
Brooklyn, NY 11201

**Abstract:** We have conducted an undergraduate research project “Proposing a New Study in Non-Invasive Amperometric Glucose Sensing Technology through the NYC-LSAMP Summer Fellowship Program” – with a freshman student. Since a non-invasive method of monitoring blood glucose would present major advantages over existing methods which use invasive technologies, our group has studied the possibility of using a novel sensing technology, an amperometric glucose sensor, based on the information derived from the relationship between glucose molecules and their electrochemical impedance within physiologic glucose levels. Changes in glucose concentrations can be monitored by measuring the impedance within a wide range of frequencies in order to optimize the impact of glucose solution via a DC/AC electrical current. We will also investigate the impedance and electrical current variation in terms of the glucose concentration within a given physiologic range. The impedance of tap water and distilled water is (50 ml each) and will be also measured by using an EIS (electro-chemical impedance spectroscopy) system. The proposed amperometric technology is sensing tear glucose levels, potentially blood glucose monitoring, may be useful as a new approach for non-invasive glucose sensing. Our amperometric glucose sensor, integrated with a disposable contact lens embedded with a glucose sensing metal, may be more economical and safe than existing methods. In this study, we will discuss how to initiate the undergraduate research and how to solve some challenging issues due to the freshman student’s level of engineering knowledge and skills. Our student (research assistant) is currently pursuing a Bachelor of Technology degree in Telecommunications Engineering Technology at NY City College of Technology of CUNY.

**Key words:** undergraduate research, NYC-LSAMP program, monitoring blood glucose, noninvasive method, amperometric glucose sensor, impedance, electrical current, EIS system, contact lens, NYCCT

## Introduction

Diabetes mellitus is a serious disease in which the body doesn't produce or properly use insulin and represents one of the major health problems in society and a chronic disease that requires long-term medical attention. Often, diabetes can lead to many serious medical problems. These include blindness, kidney disease, nervous system disease, limb amputations, stroke and cardiovascular disease (CVD). According to Data from the 2011 National Diabetes Fact Sheet, an estimated 25.8 million children and adults in the United States—8.3 percent of the population— have diabetes and the estimated cost of diabetes-related health care in the United States is approximately \$174 billion annually, including \$116 billion in direct medical costs [1, 2]. It is a disproportionately expensive disease; in the United States in 2002, the individual cost of health care was \$13,243 for people with diabetes, while it was \$2,560 for those without diabetes [3].

The recent multi-center NIH studies have indicated that the health risks associated with diabetes are significantly reduced when the blood glucose levels are well and frequently

controlled, indicating that it is prudent to measure the blood glucose as often as five or six times a day. Thus it is very important that proper monitoring be done by diabetics at home or at work [4]. At present all existing methods of home blood glucose monitoring require drawing a blood sample by piercing the skin (typically, on the finger). This method strongly discourages patients' compliance and has serious drawbacks because the procedure is invasive.

Since a non-invasive method of monitoring blood glucose would present major advantages over current existing methods which are using invasive technologies, our group has explored a noninvasive glucose sensing technique and reports preliminary results, finding a relationship between the concentration of glucose in aqueous solution and the solutions' impedance up to concentration of 1,000 mg/dl. The proposed glucose sensing amperometric system in current study may prove capable of monitoring very low glucose levels with the accuracy and precision that would satisfy medical use criteria at a cost that is significantly lower than costs for existing methods. In addition, the patient acceptance for this methodology is expected to be high due to its non-invasive nature, and its simple and safe testing procedure.

## **Background**

There has been an increasing demand for continuous, non-invasive glucose monitoring techniques due to the increasing number of people diagnosed with diabetes and the recognition of the fact that the long-term outcome of these patients can be dramatically improved by a careful frequent and accurate glucose monitoring and control. In a previous study, we reviewed several of the newest minimally invasive and non-invasive glucose monitoring technologies under development or introduced to current market such as near infrared (NIR) spectroscopy, mid infrared (MIR) spectroscopy, radio wave impedance, optical rotation of polarized light, fluid extraction from the skin, interstitial fluid harvesting, and glucose sensing contact lens with fluorescence detection. Although recent advances in technology, research, and clinical applications in the noninvasive glucose monitoring are very encouraging and promising, we believe the non-invasive glucose sensing techniques are still a little far from satisfying requirements for clinical use. Therefore, it is necessary to develop a new technique satisfying the criteria such as accuracy, low cost, simplicity in testing, portability, and safety in use [5, 6].

## **The NYC-LSAMP Summer Fellowship Program**

The NYC Louis Stokes Alliance for Minority Participation (NYC-LSAMP) is an alliance of 16 CUNY Colleges and the CUNY Graduate Center. The Alliance goal is to substantially increase the number of underrepresented minority students who pursue and graduate with Baccalaureate Degrees in Science, Technology, Engineering and Mathematics (STEM). The Alliance provides various financial incentives for both faculty and students and supports research training opportunities and academic support services for students to encourage greater participation to CUNY students majoring in the STEM disciplines [7].

The NYC-LSAMP Summer Fellowship Program provides a research experience program for a period of 10 weeks during the summer. Students receive a scholarship of \$5,000.00 for the summer. AMP research assistantships are awarded on the basis of students' overall GPA, academic achievement, and the recommendation of their faculty mentor. Students give written reports of weekly progress and a final report on their research; they present results at a poster session at the end of the summer [8].

## **Initiating Undergraduate Research**

In a previous study, we described problems in initiating research with freshman students who

lack adequate theoretical and experimental knowledge and skills in manipulating highly elaborate equipment and materials. Since The NYC-LSAMP Summer Fellowship Program is designed to complete student's project within a period of 10 weeks during the summer, we began with a series of lectures to help students to gain depth of knowledge in Electrical and Biomedical engineering principles and project - related theoretical and experimental background information, along with problem-solving and trouble-shooting skills.

## **Plan of Study**

Elevated tear glucose levels during hyperglycemia were first demonstrated by Michail and his coresearchers [9]. According to their study, the tear glucose concentration follows blood glucose level with the glucose between blood and tissue fluid exists in an analogous manner to the equilibrium. Many scientists have reported that actual glucose concentrations in tears are low and in the range of 50-500  $\mu M$ . More recently, Chatterjee et al. [10] and Zhu et al. [11] successfully demonstrated the relationship between tear and blood glucose concentrations and to develop a rapid method of detection of tear glucose level semi-quantitatively with glucose oxidase enzyme impregnated strips and to evaluate its role as an indicator of blood glucose level.

The concept of using tear fluid glucose will be employed as a way to follow the level of blood glucose in this study.

Since the purpose of our study is to investigate a technology that measures the relationship between concentration of glucose molecules and electric current due to changes in impedance. During investigation of literature, we found that there were impedance variations in glucose – water solutions with different concentration values that mimic glycemic levels in human blood [12, 13]. When glucose molecules are dissolved in solutions, the impedance of the solution changes and a relationship between them occur, which also allows the verification of its relationship with current. This finding can be applied to develop a new technology for the noninvasive monitoring of tear glucose levels, potentially plasma glucose monitoring in tears, using a disposable contact lens embedded with glucose sensing metal that is fast and simple sensor for diabetics.

The aim of our study at this preliminary stage was to examine the impedance of glucose solution at different glucose concentrations within the physiological range (100 – 500 mg/dl). We will also investigate various glucose concentrations from both distilled water and tap water to see which solution generates a reasonable amount of current (nano/pico amperes) needed for the data to be used for further studies. Our tear glucose is based on measuring a very low current, most likely in a nano-or pico-ampere scale. Since the concept of using tear fluid glucose will be employed as a way to follow the level of blood glucose in future studies, and test much lower concentration of glucose and introduce other ions that would mimic the physiological composition of human tears (e.g, Na<sup>+</sup>, K<sup>+</sup>, and Cl<sup>-</sup> ions).

## **Materials and Methods**

We employed a Gamry Potentiostat/ Galvanostat Reference 600 system as shown in Figure 1 to measure the levels of impedance in tap and distilled water. The system was first calibrated with a 2-k $\Omega$  dummy cell as shown in Figure 2 in order to test accuracy of the system and found 99.8% accurate result. Water was distilled in a Barnstead/Thermolyne model A1015-C still. Samples of two different solutions- tap water and distilled water- were also tested to find their impedance by using the EIS system. We then further applied the system to investigate

impedance variation in the 50 ml of two solutions presented (tap and distilled water) at wide range of frequencies ranging from 100 mHz to 1MHz at temperature of 23.9°C and 24.3°C respectively. Dextrose glucose, Anhydrous from Fisher Scientific was used to create glucose solution at room temperature with physiologic range concentration including 100 to 400 mg/dl. We also took measurements of higher concentration of 500mg/dl and 1000mg/dl for further determination of the relationship between impedance and glucose molecule. Each sample consisted of 50ml of distilled water and remarkable relationship was observed during our preliminary research.

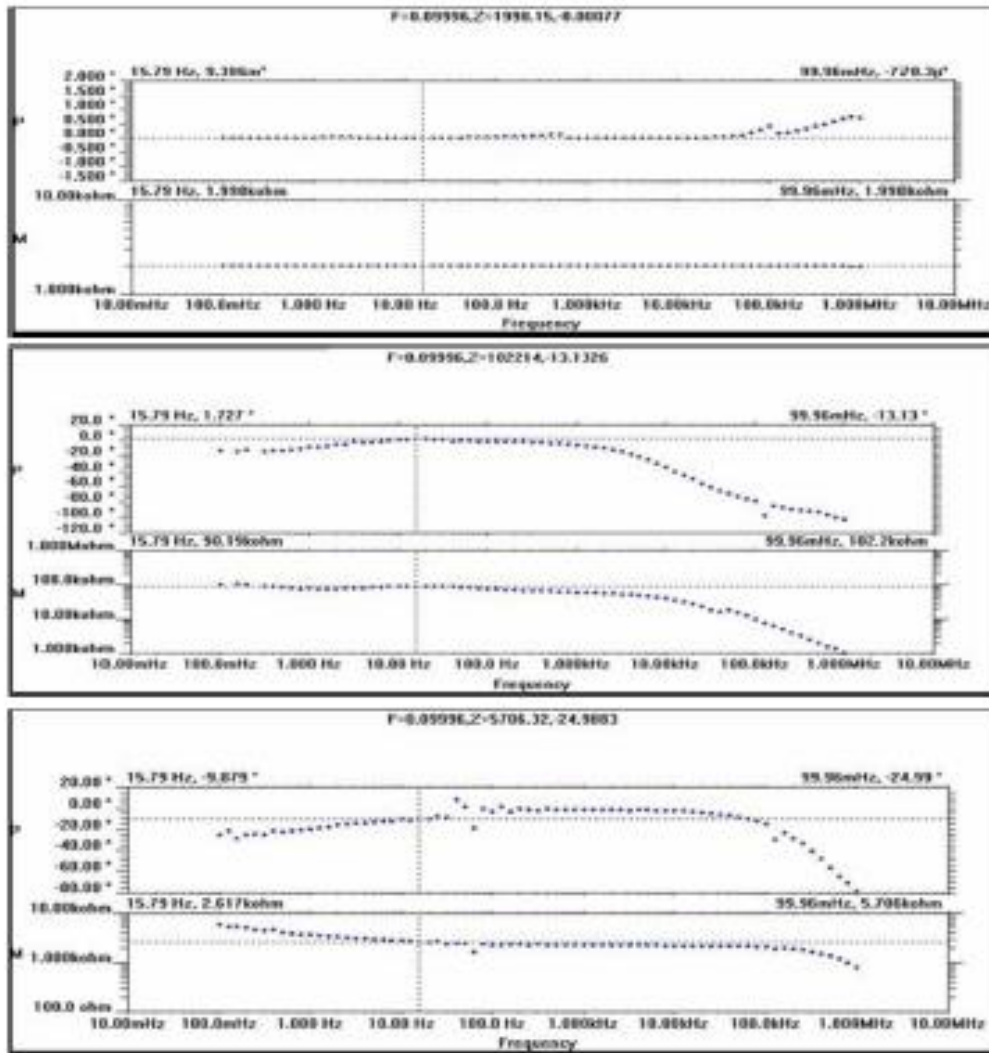


**Figure 1:** Gamry Reference 600 EIS System **Figure 2:** Dummy cell with 2 k $\Omega$  resistor. (Electrochemical impedance spectroscopy) [14]

## Results

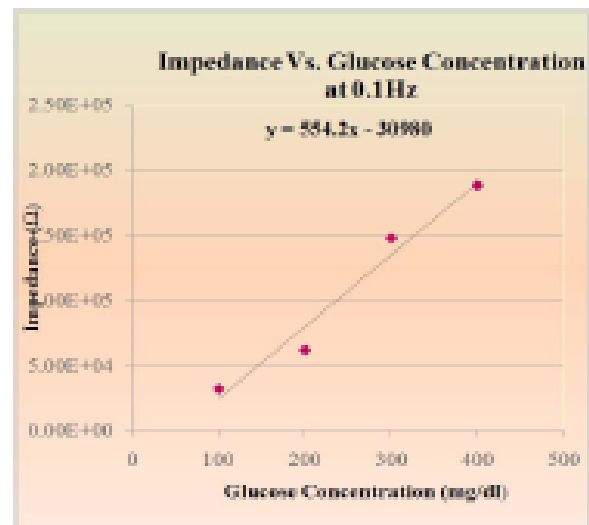
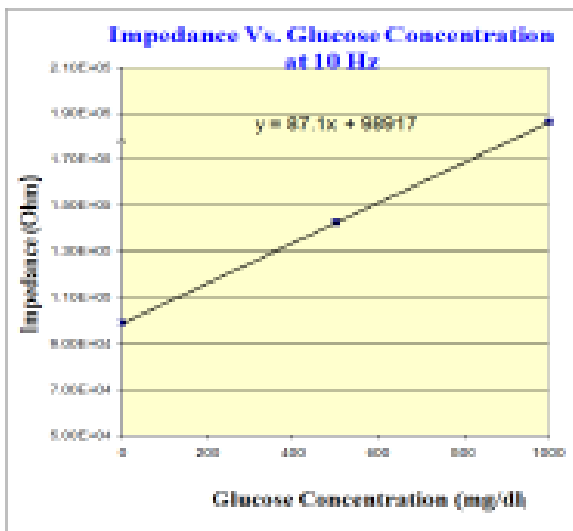
We calibrated the system several times with a dummy cell consisting of a 2 k $\Omega$  resistor. Figure 3(a) shows that the calibration result was 99.8% accuracy resulting in 1.998 k $\Omega$  impedance which gave us confidence taking further measurements with water samples. According to the experimental data plots shown in Figure 3(b) and (c) of impedance measurement, we found that the impedance level of distilled water is 45 times higher than that of tap water; the distilled water impedance at 15.79 Hz was 90.19 k $\Omega$ , while the impedance of tap water was 2.1 k $\Omega$  at the same point/ frequency range. The result indicates that the distilled water has higher purity and fewer electrically conductive ions present than tap water. We also observed a significant phase shift that occurred at high frequency around 5 kHz for distilled water and 100 kHz for tap water. However, no phase shift occurred for 2 k $\Omega$  dummy cell regardless of frequency range due to its pure resistive characteristics.





**Figure 3:** The experimental data plots of impedance measurement using a Gamry Potentiostat/

Galvanostat reference 600 system (a) 2.0 kΩ dummy cell (b) Distilled water (c) Tap water. Figure 4 presents the impedance of distilled water and of glucose solutions at various concentrations: 500 mg/dl, and 1,000 mg/dl; we found the best sensitivity at 10Hz. The slope at the point was 87.1 ( $87.1x + 98917$ ) which means that for every 1 mg/dl increase of glucose concentration, there is about 87.1 Ω increase in impedance. We further investigated the impedance at lower concentrations between 100-400 mg/dl and found the best sensitivity point at 0.1Hz. The slope of this measurement was 554.2 ( $554.2x - 30980$ ) and we noted that effects are more relevant at frequencies below the 1 MHz band. i.e. higher frequency resulted in lower impedance and starts to fall at 100kHz (the frequency variation was nonlinear). Our preliminary experimental results showed that glucose concentration has direct proportional relationship to impedance. Linear relationships between glucose molecule and water are presented in Figures 4 and 5.



**Figure 4:** Graph showing a linear relationship between 0mg/dl, 500 mg/dl and 1000mg/dl. **Figure 5:** Graph showing a linear relationship between 100 mg/dl - 400 mg/dl.

### Conclusions

We have successfully demonstrated the relationship between glucose concentration and electrochemical impedance. These findings will be applied to develop a new technique for the non-invasive amperometric sensor monitoring of tear glucose concentrations for application in plasma glucose monitoring. According to our experimental data, we can conclude that there is enough system sensitivity to identify glucose concentration of solution. This is a very significant finding because as far as we know this is the first time to present the numerical relationship between glucose concentration and impedance. We also confirmed that impedance variations due to changes of glucose concentrations are certainly more evident at lower frequencies most especially close to DC. This result basically agrees with previous findings from other research groups, since Tura and Iguchi demonstrated that the variations of voltage and current which are related to the conductivity of solutions due to changes in glucose concentration can be observed [15, 16]. We strongly believe our preliminary research is very significant and important step to our ultimate goal of study in developing a non-invasive pure electrical current glucose sensing device for diabetics. Optically pure D-glucose while others used racemic (mixed D and L) glucose is it reasonable that the impedance INCREASES with increased glucose concentration? I would have thought that glucose served to facilitate conductivity, and therefore DECREASE impedance

The NYC-LSAMP Summer Research Program truly helped our student in gaining intellectual and practical knowledge of research. Through the various research activities required by program, the student also gained confidence with completing research project. Our student (research assistance) is currently pursuing a Bachelor of Technology degree in Telecommunications Engineering Technology at NY City College of Technology of CUNY. With the guidance and help of one of the co-authors of this paper, she also worked for NSF REU

program provides opportunities for undergraduate students of CUNY to become active participants in Remote Sensing research at the NOAA Cooperative Remote Sensing Science and Technology Center (NOAA-CREST) over last summer at CCNY.

## References

1. Coster S.; Gulliford M.C.; Seed P.T.; Powrie J.K.; Swaminathan R.: "Monitoring Blood Glucose Control in Diabetes Mellitus: A Systematic Review", *Health Technology Assessment*, 2000, vol. 4, no. 12.
2. Report of the expert committee on the diagnosis and classification of diabetes mellitus. *Diabetes Care*. Jan 2003;26 Suppl 1:S5-20.
3. Laditka SB, Mastanduno MP, Laditka JN. Health care use of individuals with diabetes in an employer-based insurance population. *Arch Intern Med*. May 28 2001;161(10):1301-8.
4. National Diabetes Information Clearinghouse (NDIC) Report in U.S. Department of Health and Human Services, <http://diabetes.niddk.nih.gov/dm/pubs/overview>, 2011.
5. Jang S., Ciszowska M., Russo R., Li H, "A New Approach to Glucose Monitoring Using a Non-Invasive Ocular Amperometric Electro-Chemical Glucose Sensor for the Diabetics", the ASEE Mid-Atlantic Section Spring 2006 conference, Brooklyn, NY, April 28-29, 2006.
6. Jang S., Russo R., Li H, "Modifying the Existing Non-invasive Optical Glucose Sensing Device and Demonstrating the Optical Rotatory Effect of Glucose in the Presence of Glucose Medium", the ASEE Mid-Atlantic Section Spring 2007 conference at NJIT, Newark, NJ, April 13-14, 2007.
7. The NYC Louis Stokes Alliance for Minority Participation (NYCLSAMP), <http://nycamp.cuny.edu/NYCLSAMP/tabid/57/Default.aspx>
8. Jang S., Markowitz K., "Initiating the Undergraduate Research Study through the CUNY LSAMP Summer Fellowship Program," the ASEE Southeastern Section Conference at Virginia Tech, April 18-20, 2010, Blacksburg, VA.
9. Michail D., Zolog, N.; C. R. Seance Soc. Biol. Ses Fil., 1937, 126, 1042
10. Chatterjee S., De S. "Estimation of Tear Glucose Level Glucose and Its Role as a Prompt Indicator of Blood Sugar Level", *Journal of the Indian Medical Association*, Vol 101 No 08, August 2003.
11. Zhu J., Lai Z. "Planar Amperometric Glucose Sensor Based on Glucose Oxidase Immobilized by Chitosan Film on Prussian Blue Layer", *Sensor*, 2002, 2, 127-136.
12. A Tura, S. Sbrinadello, S. Barison, S Conti, G. Pacini; "Impedance spectroscopy of solution at physiological glucose concentration," *Biophysical Chemistry* 129,235-241 (2007)
13. A Tura, Stefano Sbrignadello, Domenico Cianciavichia, Giovanni Pacini and Paolo Ravazzani; "A Low Frequency Electromagnetic Sensor for Indirect Measurement of Glucose Concentration: In Vitro Experiments in Different Conductive Solutions," *Sensors* 10, 5346-5358 (2010)
14. Gamry Instruments: <http://www.gamry.com/HomePage/Index.html>
15. A Tura, Stefano Sbrignadello, Domenico Cianciavichia, Giovanni Pacini and Paolo Ravazzani; "A Low Frequency Electromagnetic Sensor for Indirect Measurement of Glucose Concentration: *In Vitro Experiments in Different Conductive Solutions*," *Sensors* 10, 5346-5358 (2010).
16. S Iguchi, H Kudo, M Ogawa, H Saito, K Otsuka; "A Flexible and Wearable Biosensor for Tear Glucose Measurement" *Biomed Microdevices* 9:603-609 (2007).

## **Self-Replicating Open Source Rapid Prototyping in the Engineering Classroom**

DAVID B. SAINT JOHN,

Ph.D. Candidate in the Materials Science and Engineering Department at the Pennsylvania State University. In addition to rebrap-related efforts, his primary research is currently focused on the use of spectroscopic ellipsometry and transmission electron microscopy for characterization of amorphous hydrogenated germanium thin films.

ERIC M. FURJANIC

Graduate of the Department of Anthropology at the Pennsylvania State University, Eric is a co-founder of the State College Rebrap Users Group and Intercollegiate Future Society. He recently finished work as a contributing editor for Philip K. Dick's posthumous work: *Exegesis*, and plans to continue helping develop low-cost DIY genetics applications for the Rebrap.

RICHARD DOYLE,

Professor of English and Information Sciences and Technology at the Pennsylvania State University, he is also the author of a trilogy of books on information and the life sciences. The latest, *Darwin's Pharmacy: Sex, Plants, and the Evolution of the Noösphere*, was published by the University of Washington Press in 2011.

RICHARD DEVON

Professor of Engineering Design, Engineering Design Program, SEDTAPP, Penn State University. He was Interim Director of the Science Technology and Society Program for two years, Director for six years of the PA Space Grant consortium, and founding Director of the Engineering Design Program. He teaches, researches, and publishes on design education, with current interests in using the Cloud computing, global design, and rapid prototyping.

## **Self-Replicating Open Source Rapid Prototyping in the Engineering Classroom**

From its genesis as a lark in the home basement lab of the senior author in the fall of 2010, the [Area] Reprap Project grew rapidly. It was offered as a group research project in Spring semester 2011 and 10 students quickly signed up and spent the semester building three functional RepRap fused-filament printers. In Fall 2011, it has evolved into an innovative course using a wiki as its textbook, a grading system based in “experience points” (XP), and self-directed “missions” chosen by students according to their interests in exchange for a predetermined amount of XP. This resulted in an intensely productive, highly collaborative fab-lab environment where students are successfully assembling four more RepRap printers. In spring and fall they have also learned to produce computer models with a 3D scanner to be used as printable files, designed and printed upgrades to the machines, and gave back to the RepRap open source community by filling in what gaps they could in the public documentation. These printers, in turn, have been used to produce the structural components for four more Repraps of our collective’s own modified design which will be the starting project of our now heavily-overbooked second iteration of the RepRap RPG course.

Our class’ structure mimics the work of Professor Lee Sheldon of Rensselaer Polytechnic Institute, who found that class participation, attendance, and grades improved when he switched from a percentage style grading system - where a student begins the semester with 100 percent and loses points from there - to one styled like a role playing game (RPG) where a student begins at level one with 0 experience points (XP) and earns cumulative XP throughout the semester in order to “level-up” their grade. Like many modern multiplayer games, our class included achievements with small rewards for notable achievements and incremental progress, as well as missions; previously defined or student-proposed projects worth agreed-upon set amounts of XP.

A strange hybrid between low-tech and high-tech, the Reprap project stands as a striking example of an emergent technology which rides the cutting edge not because it has never been done before, but because it has never been in the hands of the global community before. Such a project would not have been possible a few years ago, when the cheapest 3D printers cost the same as a comfortably accoutered automobile and all the technology driving them was, and still remains, zealously guarded as proprietary intellectual property. Thanks to all of these contributions to the public domain, hands-on experience with computerized materialization is now an affordable possibility in the classroom; the CAD models created by students are no longer simply useful for generating schematics, but can become something tangible.

### **Introduction**

This text seeks to report recent rewarding efforts which have taken place at [University Area], integrating open source 3D printing technologies into an educational environment using both labs and lectures. This work has not been the product of any ‘top-down’ grants or external funding, but was a true ‘bottom up’ development, which we believe to be capable of a wide range of scalability. We emphasize this for the sake of

educators who may write off this type of project as being beyond their budget - in lieu of funding - we hope to provide encouragement to the interested.

### **A Brief Background on RepRap Technology**

A number of evolutions, variations, and improvements from both commercial vendors and the open-source community have led to a generation of 3D printers which cost approximately 3% of a commercial machine's retail value, have a tool-chain of entirely open-source programs available to run them, and can use the inexpensive bio-degradable thermoplastic polylactic acid (PLA) as a feed stock while still producing models with more structural integrity than many much more expensive powder printers.

One of the precursors to this development was the debut of the programmable, publicly licensed, open-hardware Arduino micro-controller, which has drastically modified the breadth and depth of do-it-yourself (DIY) projects over the past several years. The project, founded by Massimo Banzi and David Cuartielles, emerged from a synthesis of a number of projects and contributions, such as Hernando Barragán's senior thesis - an open source micro-controller programming language with an integrated development environment (IDE) called "Wiring" which evolved out of "Processing" by Casey Reas and Ben Fry.

Among the most visible advances in 3D rapid prototyping enabled by the Arduino is the RepRap Project. RepRap is short for replicating rapid prototyper; a machine designed to be made of pieces it could print itself. This is in stark contrast to the expensive non-self replicating designs which have dominated the commercial prototyping market for the last 30 years.

The RepRap project was started by professor Adrian Bowyer in 2005, whose first RepRap design, the "Darwin," would be released to the open source community in 2007. His graduate student, Edward Sells, would later redesign the RepRap Darwin, producing what is now known as a "Mendel" design.

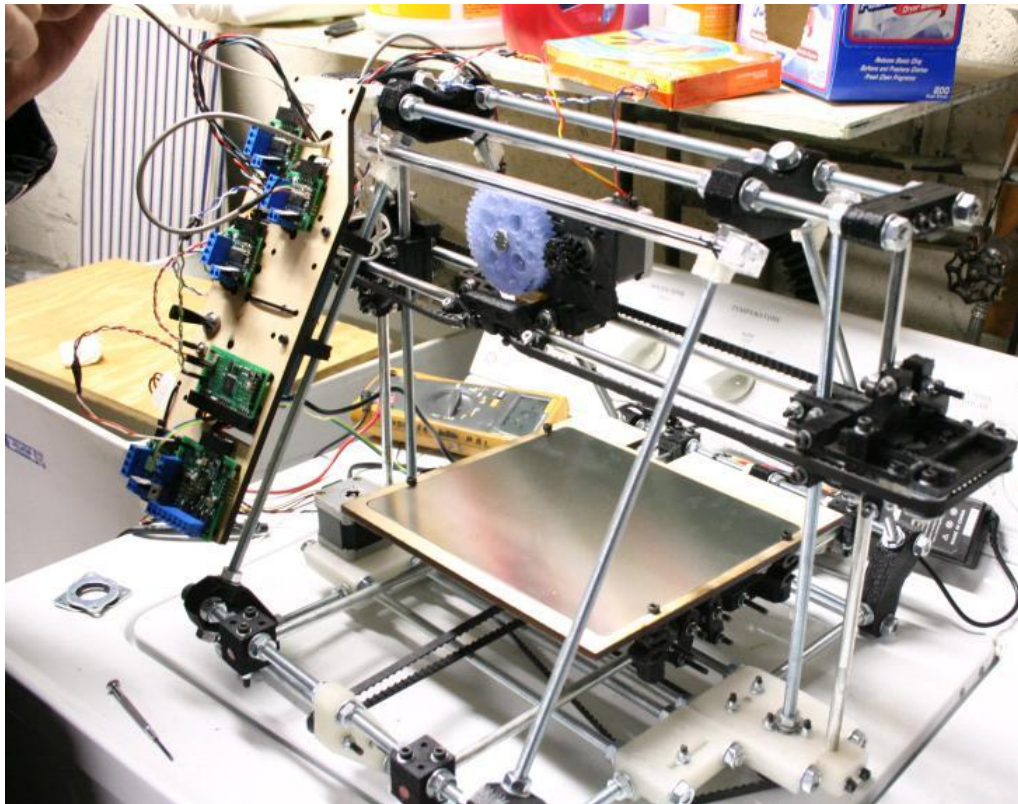


Fig. 1. A RepRap Mendel.

These designs are not the terminus of the RepRap project, though they are likely the end of any 'official' variants as Professor Bowyer has expressed that the open source movement itself will decide what future variants are worth development and production, without any authoritarian fiat from 'above'. Many of the various RepRap designs being field tested can be seen at the RepRap Family Tree - including that of our own class' design, the [Model Name] Mendel. ([http://reprap.org/wiki/RepRap\\_Family\\_Tree](http://reprap.org/wiki/RepRap_Family_Tree)).

Specifications vary somewhat depending on the breed of Reprap, but a standard Mendel occupies a volume of 500 mm (X) by 400 mm (Y) by 360 mm (Z), and has a build envelope of 200 mm (X) x 200 mm (Y) x 140 mm (Z). In addition to PLA, it can print acrylonitrile butadiene styrene (ABS) so long as it has a heated print-bed.

### **RepRap RPG 1.0: A Course for all Majors**

In October 2010, a laser-cut wooden reppap mendel kit was purchased with personal funds from one of several available online vendors by one of the authors. This system was producing useful parts by December 2010, and a course was posted with little notice for spring 2011. This spring class of 11 students met once per week, and was able to assemble and perform some troubleshooting on two Mendels and a Huxley in the course of the semester. In tandem with this, students learned to operate a 3D scanner in order to create models, and designed, printed and tested both a filament spool and a pen-plotter modification. These printers are now the parents of the four Repraps being built in RRRPG 2.0 for our fall semester, and our electronics team is attempting to use last season's pen-plotter to etch PCB electronics boards of our own improved design for future classes.

Our class' grading structure is loosely based on the work of Professor Lee Sheldon of Rensselaer Polytechnic Institute, who found that class participation, attendance, and grades improved in his classes when he switched from a percentage style grading system - one where a student begins the semester with 100% and only loses points from there - to one styled like a role playing game (RPG), where a student begins with zero experience points (XP) and earns them throughout the semester in order to "level-up" their grade.

In our version, students could gain XP in a number of ways. Simply showing up, contrary to Woody Allen's estimations, calculated out to be worth 53% of the XP needed for an A. Taking a cue from the psychology behind modern game design, we implemented "achievements" with small XP rewards to incentivize activities such as participating in class lectures, taking the 'print-license' test, or learning to use more complex G-Code generators in order to improve object quality.

The most central element of the experience point system, however, is that allows for missions; previously defined or student-proposed projects worth agreed-upon amounts of XP. The first mission given to every student was a mandatory one involving a small team effort to assemble a functional RepRap printer. Once completed, students can then choose to undertake any missions they please from a master list of projects which aim to improve the local fab-lab or RepRap community as a whole. These include tasks such as modifying structural models to remedy design flaws found by the group or learning how to retrofit heated print-beds onto our machines to enable use of new types of filament. This non-linear system also encourages student innovation by allowing them to propose their own projects for approval by the instructors, leading to such interesting projects as that of one student who developed code capable of transforming atomic force microscopy data (AFM) into printable topography.

We calibrated the value of XP in our system to the [University Name's] expectation that each credit hour taken for a semester should involve 40 hours of dedicated, focused involvement on the part of a student. By defining 100 XP as equivalent to one hour of "gear time," we decided Level 12 would be our A level for three credit students, set at 12,000 XP. Attendance, defined in our syllabus as "being here and not useless," would net students 200 per session, totaling 6400. Since we knew the RepRap build projects themselves would likely take half of the semester, we set that mission's maximum reward at half of the non-attendance points needed by an A student - 3000 in this case. The remainder of their points would be composed of completing other missions, achievements, and contributions to the wiki.

Our experiences have been akin to Professor Sheldon's: We find that our students are highly motivated to participate and contribute to the course - each sculpting their own class experience to suit their strengths, entertain their interests, or improve upon areas in which they feel inexperienced. While the course was listed under the Department of Engineering Design, it was predominantly populated by undergraduates from electrical engineering, mechanical engineering, and aerospace programs.

### **Replication and Mutation of RepRap RPG**

There are two aspects to the course described above which other educators may have interest emulating, either together or separately: using RepRap technology in a classroom setting, and operating the course using an RPG-derived points system. These



two parts have seemed to be synergistic in our experience, but it is worth discussing their merits and variability separately.

With regard to using RepRap in the classroom, one can imagine discipline-specific courses which cover topics in addition to the general assembly, operation, troubleshooting, and maintenance which comes with the territory. Some suggested topics are listed below:

- a. Physics: heat dynamics, electronics, static forces, friction, etc.
- b. Engineering Design: Solidworks/Sketchup/Blender/Openscad - (re)design and print
- c. Materials Science: Discussions of relevant polymers, metals, insulators, etc.
- d. Art/Sculpture: Reprap as a Medium
- e. Electrical Engineering: RepRap-created electronics for RepRaps
- f. Computer Programming: Firmware, software, G-Code refinement
- g. Mechanical Engineering: Building/modifying Repraps, analysis of currently used designs
- h. Law/Ethics: Patents, design, and desktop fabrication
- i. Psychology: Prototyping and cognition

With scalable, customizable, hands-on 3d prototyping experiences at relatively low cost for college or high school classrooms, this type of project provides plentiful opportunities for interdisciplinary collaboration.

The merits and flaws of the RPG grading system deserve better analysis than will be given here, but the inspiration for their use is a presentation by which gives some insight into how one might approach the use of such a grading system<sup>1</sup>. When considering whether or not to use an 'RPG-like' point system for class operation it is important to consider that the grading is inevitably more involved than traditional grades, depending on the complexity of the point system in use. Sheldon's own syllabus<sup>2</sup>, along with tools for designing your own version<sup>3</sup>, are available online for open source remixing.

### **Future Endeavours and Visions**

In addition to redesign and printing of models, building of repraps, and other assorted projects, there are several other interesting projects that are an easy next step. Combined with a 3D scanner, students were able to import structures from the real world for replication, and the number of open source 3D scanning platforms is growing. With the collaboration of Professor [John Doe] of the Anthropology Department, our students will be able to scan and print their own faces. With the involvement student robotics club, we are currently planning to help build parts for either a bipedal robot or a quadra-copter. Most ambitious yet most developed of all is our prototype of an alternative toolhead and print-bed which, like an "app," would allow a standard Mendel to preform automated polymerase chain reactions in order to amplify DNA for low-cost testing.

### **Summary**

Thanks to all of these contributions to the public domain, hands-on experience with computerized materialization is now an affordable possibility in the classroom; the CAD models created by students are no longer simply useful for generating schematics, but can become something tangible and useful. At the crossroads of so many fields, this project not only teaches students about a new and popular technology, but gives them an environment where their projects are not discarded or deleted at the end of the semester; rather, they live on as contributions to the overarching body of collaborative work at the heart of the global Reprap project, growing it larger, piece by piece.

### **Citations**

[1] <http://g4tv.com/videos/44277/DICE-2010-Design-Outside-the-Box-Presentation/>

[2] <http://gamingtheclassroom.wordpress.com/syllabus/>

[3] [http://terranova.blogs.com/terra\\_nova/2010/03/build-your-own-sheldon-syllabus.html](http://terranova.blogs.com/terra_nova/2010/03/build-your-own-sheldon-syllabus.html)

**Written Knowledge and Complex Technology:  
A Case Study of the American Institute of Mining Engineers**

Carol Siri Johnson  
Associate Professor, New Jersey Institute of Technology

# Written Knowledge and Complex Technology: A Case Study of the American Institute of Mining Engineers

Carol Siri Johnson  
Associate Professor, New Jersey Institute of Technology

September, 2011

## Abstract

Written knowledge enables complex technology. This statement marks a major shift in human activity, both in our physical surroundings and in our mental activity. This paper describes the early publication history of the American Institute of Mining Engineers (AIME), founded in 1871, as they sought to create an industrial knowledge-base. AIME was a professional society dedicated to gathering, verifying, mediating and publishing current written, drawn, and quantitative knowledge about the iron and steel industries. As the number of technological discoveries increased and the industry became more complex, AIME split into divisions reflecting the current fields of growth. By the end of the 20th century, most of the divisions of AIME stopped publishing, signaling a decline in the steel industry in the United States. The theme here is that codified knowledge and complex technology grow and fade as two sides of one coin.

## Introduction

The American Institute of Mining Engineers (AIME) was an integral part of the development of the American iron and steel industry. Their main *raison d'être* was the development of written knowledge. They peer reviewed and formally published thousands of papers on multiple disciplines about the multiple industrial processes. In the 1971 AIME Centennial Volume's historical summary describes the publication of papers and books as "the very reason for being" [1]. The body of work that AIME has left behind runs into thousands of volumes and provides a history of technological and scientific ideas on many aspects of the evolution of industry, including, eventually, the death of steel in the United States.

There is some knowledge that relies on intuitive physical or tacit (nonverbal) knowledge. This knowledge is necessary and runs in parallel to written knowledge in the

development and operation of complex technology. For instance, David Thomas, the first (mainly honorary) president of AIME created a method of hot blast using common anthracite coal, thereby ushering in the age of Big Steel. He did this while sitting in a parlor, watching an anthracite fire spit and fizzle. He had just been discussing a pamphlet about using hot blast in an iron furnace, a new concept, when suddenly he got an idea that if he used a hot blast on anthracite coal it would make it “burn like pine” [2]. This is the power of tacit knowledge in combination with printed knowledge.

AIME publications created a vast library, detailing the evolution of the iron, steel, mining and petroleum industries from 1871 to the present. AIME’s major publication was the *Transactions of the American Institute of Mining Engineers* (TAIME). This paper will describe some of the development and changes in AIME’s publication history [3]. The publications changed as the industry changed and the publications declined when the industry declined in the United States. Now, instead of writing papers on new methods for metals manufacturing steel, AIME is a historical educational foundation.

## **Background**

Three important predecessors to AIME were the Royal Society of London (upon which model most subsequent professional and scientific societies were formed), the increase of visual images published in-line with text and the *Engineering and Mining Journal*, which was the direct predecessor of TAIMÉ. The Royal Society provided a model, the increase in visual communication allowed the communication of complex technical ideas in print, and the *Engineering and Mining Journal* represented fast and inexpensive publication of industrial knowledge from geographically wide-ranging sources. It was also

### *The Emergence of Knowledge-sharing Organizations: The Royal Society of London*

The model for most scientific society publications was the *Philosophical Transactions of the Royal Society of London*. The Royal Society was officially founded in 1660 in order to show experiment demonstrations and read papers. The first collector and editor of the papers did so for profit (and was disappointed), beginning in 1665. Mr. Oldenburg, born in Germany, published No. 1 through No. 136 (1665-1677). His stated purpose was:

... for the advancement of science and the benefit of mankind, to make known to the world, through this channel, the results of the labours, not only of those persons who were members of this Society, but also of other learned men, in this and other countries; that by the communication of such discoveries others might be stimulated and encouraged to similar exertions, in promoting and extending the various branches of natural knowledge [4].

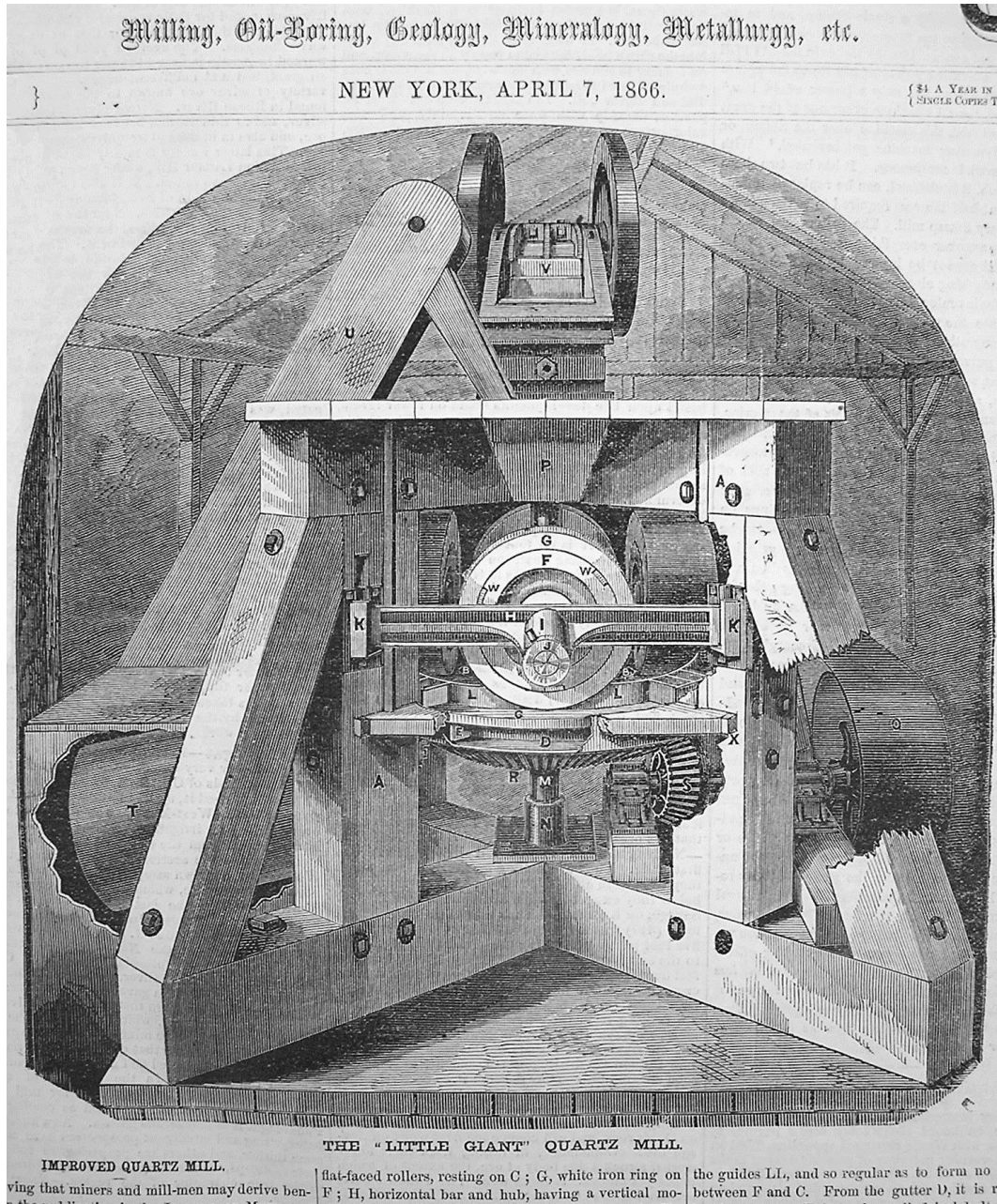
It reprints the major articles, summarizes the minor ones and provides historical annotations. The Royal Society continued conducting experiments and collecting papers, providing a rich source on the emergence of science in the western world. In 1809, an abridged summary of the first published papers (1665 to 1800) was collected and annotated by editors who added historical data, so it is still possible to study these journals today. Although it was based on the scientific method of Francis Bacon and the transactions contain significant papers of major scientists such as Robert Hooke and Isaac Newton, they also contain hundreds of minor collected observations on all aspects of the natural world from many different people, such as “On Glow-worms,” “Damps of the Hungarian Mines,” “Curiosities about Connecticut,” and “On the Large-breasted Woman.” At times, during its publication, the *Philosophical Transactions* were in disfavor among serious scientists [5].

### *The Emergence of Visual Communication*

In the mid-19<sup>th</sup> century, it became possible to have inexpensive images printed in-line with text. Prior to that, images were expensive and rare, and often printed as plates at the end of a book or in a separate book [6]. William Ivins, who was Curator of Prints at the Metropolitan Museum of Art in New York City for thirty years, wrote that the emergence of the “exactly repeatable image” was a revolutionary advance for science and technology. He viewed prints as the most important tool of modern life, with “incalculable effects upon knowledge and thought, upon science and technology, of every kind.” He goes so far as to say that “since the invention of writing there has been no more important invention than that of the exactly repeatable pictorial statement” [7].

The Royal Society used written, visual and quantitative information pathways and many other societies imitated this method. The quality of the illustrations increased in complexity and resolution through time. The advantages of complex images printed in-line

with the text can be seen in Fig. 1, an illustration from the *Engineering and Mining Journal*, which relays more information than is possible with words alone. When illustrations such as this became common, the stage was set for rapid communication and innovation in creating new technologies.



**Figure 1** – Illustration of a Quartz Mill on the front page of the *Journal of Mining* in 1866. Better technology, smooth paper and improved woodcut technique made inexpensive newspapers possible on a wide scale in the mid-19<sup>th</sup> century.

*The Emergence of Inexpensive and Rapid Printmaking Technology: The Engineering and Mining Journal*

The *Engineering and Mining Journal* (EMJ) preceded TAIME by several years and then became the official “Organ of AIME.” EMJ was started in 1866 as the *American journal of mining, milling, oil-boring, geology, mineralogy, metallurgy, chemistry, etc.* At first it carried information about the deposits of gold and silver in the American west. EMJ published packets of information about a variety of topics, including reports on mining activities from every region of the country (that arrived by steamship), notes on inventions, poems, patents pending, brief discussions of geology, machinery, chemistry, prices for coal, securities, gold and other minerals, and advertisements and filler. AIME and TAIME grew out of EMJ – through advertisement, a group proposed to create a society in which “members exchange their views, and consult for mutual advantages upon the difficulties encountered by each; these ‘Transactions’ or ‘Proceedings’ when published would form a most valuable, and greatly needed, addition to our professional literature” [8]. This model of knowledge exchange and transfer that developed in the 17<sup>th</sup> century with the Royal Society is still effective today in societies such as the ASEE.

### **19<sup>th</sup> Century: “Renaissance Personality” in Industry**

The 19<sup>th</sup> century was a time of rapid experimentation and industrial development. It was also a time when disciplinary boundaries were continually shifting to make room for new discoveries and/or the discovery of new connections. Thus, during this time period, TAIME and AIME were run a man and a woman, each with a Renaissance personality [9]. Rossiter W. Raymond was the editor of EMJ and then the secretary of AIME, responsible for almost all aspects of the group including publications, a position which he held for 27 years (1884-1911). Mrs. Henry Stevens Conant, Raymond’s assistant, was a multilingual author as well. A written history of AIME, published in the seventy-fifth anniversary TAIME volume of 1947, divides its AIME’s history into two periods – pre- and post-Raymond. The post-Raymond period was a period of decentralization and redistribution of the power and responsibility over a wider range of people.

Rossiter Raymond was a knowledge-broker. He was moderator of the networked enterprise of advancing iron and steel technology. His moderating role had analogues in other technological arenas. For instance, Alexander Holley worked on the problems of the quality of steel rails, Octave Chanute moderated the information flow necessary to the invention of the airplane, and today individual moderators volunteer their time to open-



source programming projects [10]. Knowledge brokers or gatekeepers of published knowledge play a major role in keeping the knowledge disseminated relevant to the industry or the science for which it was intended.

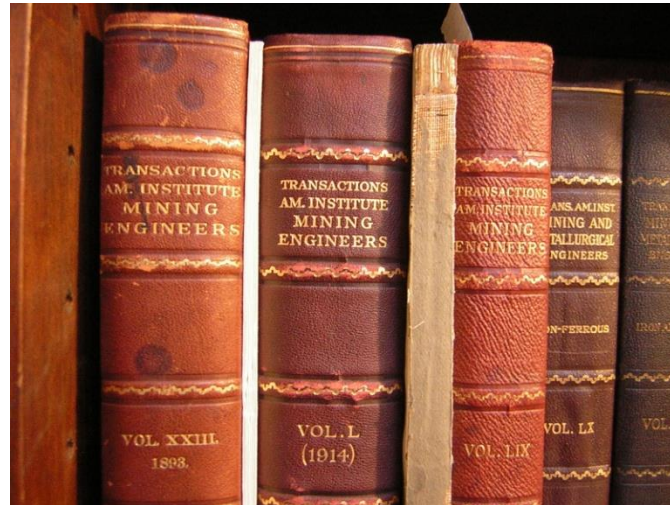
The 19<sup>th</sup> century was also a time of rapid development in office technologies such as typing and shorthand dictation. In the 1880s, women began learning shorthand and, after the turn of the 20<sup>th</sup> century, they monopolized the fields of typing and stenography. Thus, although AIME did not include women and had only one female member (Ellen Richards, joined 1879), women were at the foundation of this massive publication effort from the beginning. Sometimes you can find historical presence in absence – Conant was never mentioned, and we would not know of her today, except that she died in 1899 and Raymond wrote in a preface to TAIME: “No one but myself will ever know how much of the credit universally given to our *Transactions* for exceptional freedom from errors of the pen or the press was due to this patient and skillful worker at my side.” The authors of the papers were men, but the many of the hands editing them and putting them into print were, throughout TAIME history, women.

In the same preface in which Raymond mourns the death of Conant, Raymond took the occasion to include a description of the work process of publishing TAIME:

... this department has on hand, at any given period, an average of more than sixty papers, in various stages of publication, from the original manuscript to the final sheets (*nine times* revised) of the volume; that proofs of text and engravings are sent repeatedly to authors in all parts of the civilized world, as well as to special revisers outside of this office, besides being carefully examined here; that it is necessary to know at any moment the exact stage of every separate publication, and to secure by persistent vigilance the final preparation of all in time for the publication of the annual volume of *Transactions*; and that this volume must be ultimately examined for Errata, and indexed with fullness and accuracy – this outline of the work, I say, will sufficiently indicate the continuous, varied and onerous labor which it involves [11].

Moreover, during the publication process each written paper or industrial idea/discovery went through several stages. Most frequently it began with a talk given at one of the AIME meetings. Sometimes the conversation that followed was taken down by dictation. In the earlier years of AIME, written papers were then serialized in EMJ. The revised paper (and

sometimes the discussion) were then edited, typeset and printed in TAIME (see Figure 2). This publishing system distributed the first “draft” new knowledge rapidly for a wide audience then the second peer-reviewed and edited version that represented professional consensus. EMJ reflected the spoken world of developing knowledge and TAIME was more a repository of accepted and codified knowledge.



**Figure 2** – Volumes of the *Transactions of the American Institute of Mining Engineers* (TAIME).

This system worked well. For instance, one of the major problems with the most immediacy in the 19<sup>th</sup> century was railroad rails that shattered, causing accidents and killing many. The news articles and images had an impact and focused the public on solving the problem. A concerted effort to end this problem was begun at the founding of AIME in 1871. There are hundreds of pages of papers and recorded discussions that took place surrounding this topic and eventually an appropriate form of steel was discovered, ending the large number of ongoing railway accidents due to shattered rails.

### **20<sup>th</sup> Century: Group Knowledge**

In 1911 Raymond retired and no longer could one man hold the reins – the age of the “Renaissance Personality” was over. Raymond’s process of publishing, which had adhered to a very high standard, was restructured, restructured and then restructured again. First, a Committee of Publications was established and it created a new procedure: each paper would have two readers and if there is a difference of opinions, the discrepancy would be resolved by a third. All readers commented and make recommendations on

printed forms. The work that had formerly been done by one man and one woman was now done by a committee of sixty readers.

AIME grew both in size and in the number of disciplines it contained: as industry developed new fields, those new fields specialized and broke off, sometimes spawning new fields themselves. In 1919, the name “Metallurgy” was added: AIME became the American Institute of Mining and Metallurgical Engineers. In 1922, a Petroleum Division was added and in 1925 the Petroleum Division started to publish their own transactions. In 1946, the Petroleum Division physically left AIME’s New York City headquarters and moved to Dallas, closer to its base of operations. In 1956, the name Petroleum was added: AIME became the American Institute of Mining, Metallurgical and Petroleum Engineers.

These changes in divisions and disciplines were accompanied by changes in the society’s structures and publication processes. In 1942 a new publishing plan was created: seven subsidiary Publications Committees were developed to decentralize the society both geographically and by discipline. The papers were vetted by the local expert committees and the by a main publications committee that would create a “uniformity of standards and an equitable balance in the allotment of publication space and financial resources of various groups.” (p. 439, 1947). In the bound volumes of TAIME, all published papers were mixed – no attempt was made to organize them into fields or divisions until 1927. After 1927, the papers appeared in separate volumes, one each for petroleum, metals, iron and steel, and coal. Papers that did not fit into those divisions were still published in occasional mixed volumes.

Much of the historical data in this section was taken from *Annual Volume Seventy-Five Years of Progress in the Mineral Industry 1871-1946*, a historical volume compiled in 1947. This 817 page volume of TAIME includes historical summaries of the development of mining geology, iron and steel, nonferrous metallurgy, coal mining, petroleum, and mineral industry education. It also records the history of AIME, including photos and biographies of all of the officers and the proceedings of the 75<sup>th</sup> Anniversary Celebration. Interestingly, although women are still unrepresented within the society, on page 810 there is an acknowledgement to two women on the Institute staff who compiled the biographies and the data for the history. It specifically mentions that Katharine S. Lovell as “the only person who will ever be able to say, with truth, that she has read every word in the book – and she has read them twice. The volume itself attests to the high quality of her work.” [12].

## **The End of AIME**

Towards the end of the 20<sup>th</sup> century, much of the heavy industry in the United States was moving abroad to countries with more financial incentives such as government support, lower wages and fewer environmental controls. In 1973 the AIME business office decentralized. The mining division moved to Salt Lake City, then Colorado. The metallurgy division moved to Pittsburgh. In 1974 another society was added – Iron and Steel Society – and the four Societies (mining, metallurgy, iron and steel and petroleum) separated their incorporation in 1984. Only the Society of Petroleum Engineers continued growing. AIME today consists of the four member societies: the Association of Iron and Steel Technology (AIST), the Minerals, Metals and Materials Society (TMS), the Society for Mining, Metallurgy and Exploration (SME) and the Society of Petroleum Engineers (SPE). Most of the annual mining and metallurgical conferences today are in Australia, London, China, Chile, Canada, Italy, Singapore and Amsterdam. The headquarters of AIME, with the URL <http://www.aimehq.org/>, is now in Littleton, Colorado. Interestingly, AIME presently has two staff members, both women.

## **Conclusion**

Today, there are no publications listed on the AIME website. The organization formed and grew as needed, created and dissolved divisions as needed, codified and shared knowledge as needed, and then ceased to exist when the majority of heavy industry moved abroad. Big Steel would not have been possible without the sharing of written knowledge. That knowledge began in individual people but was communicated, modified, augmented and codified by intensive an intensive publication program for over one hundred years. The publications of AIME were a vital part of the development of the iron and steel industries as well as other, related industries, but now are largely a record of the past. The gradual decline in mining and in the steel industry in the United States gradually brought this intensive publishing process to an end.

## **Works Cited**

1. Alford, Joe B. "History of the Institute: One Hundred Years of AIME," *Centennial Volume American Institute of Mining, Metallurgical, and Petroleum Engineers 1871-1970*, New York: American Institute of Mining, Metallurgical, and Petroleum Engineers, 1971. p. 256-257.
2. Williams, Peter N. "David Thomas: Father of the American Anthracite Industry," *Historical Metallurgy*, 28(1), 1994.
3. This paper is an extract from a longer published work.
4. Hutton, Charles, George Shaw and Richard Pearson. *The Philosophical Transactions of the Royal Society of London, from their Commencement, in 1665, to the Year 1800; Abridged, with Notes and Biographic Illustrations*, Vol. 1, C. and R. Baldwin, London, 1809, p. 1.
5. See the complaints of Charles Babbage in *Royal Society*, Wikipedia, <[http://en.wikipedia.org/wiki/Royal\\_Society](http://en.wikipedia.org/wiki/Royal_Society)>, accessed June 26, 2010.
6. Johnson, Carol. "The Evolution of Illustrated Texts and Their Effect on Science: Examples from Early American State Geological Reports." *Leonardo: Journal of the International Society for the Arts, Sciences and Technology*, MIT Press (41:2), 2008.
7. Ivins, William M., *Prints and Visual Communication*, (Cambridge, MA: MIT Press, 1978), p. 3. Ivins posits that we cannot now "see" the importance of visual communication because it has become so familiar to us.
8. Alford, Joe B. "History of the Institute: One Hundred Years of AIME," *Centennial Volume American Institute of Mining, Metallurgical, and Petroleum Engineers 1871-1970*, New York: American Institute of Mining, Metallurgical, and Petroleum Engineers, 1971. p. 40.
9. By "Renaissance personality" I mean a person who functions in well a wide variety of fields rather than in a single field.
10. Meyer, Peter B. "Episodes of collective invention." US Bureau of Labor Statistics Working Paper 368. August, 2003. Available at <http://www.bls.gov/ore/pdf/ec030050.pdf>.
11. Raymond, Rossiter W. *Transactions of the American Institute of Mining Engineers*, Vol XXVIII (28), 1899, p. iii.
12. Parsons, A. B., ed. *Seventy-five Years of Progress in the Mineral Industry, 1871-1946*. American Institute of Mining and Metallurgical Engineers., Anniversary Volume, 1947, p. 810.

## **Detecting Falls Among Elderly Patients in Nursing Homes by Using Wireless Sensor Networks**

NIKOLA JOVIC, University of the District of Columbia  
Senior student in the Electrical Engineering and Computer Engineering Department

ABAYOMI DAIRO, University of the District of Columbia  
Senior student in the Electrical Engineering and Computer Engineering Department

ASHENAFI TESFAYE, University of the District of Columbia  
Junior student in the Electrical Engineering and Computer Engineering Department

AIME VALERE, University of the District of Columbia  
Junior student in the Electrical Engineering and Computer Engineering Department

YANNICK ROLAND KAMDEM, University of the District of Columbia  
Master Student in student in the Electrical Engineering and Computer Engineering  
Department

Dr. SASAN HAGHANI, University of District of Columbia  
Dr. Sasan Haghani is Assistant Professor of Electrical Engineering. He has more than 9 years of experience in the field of wireless communications and communications theory. He received a PhD in Electrical Engineering from the University of Alberta in 2007 and he was the recipient of the Alberta Ingenuity Award and the Alberta Informatics Circle of Research Excellence Award. Dr. Haghani is a Member of the IEEE.

PAUL COTAE, University of the District of Columbia  
Dr. Paul Cotae, Associate Professor of Electrical Engineering has more than 25 years of experience in the communication field (research and education). He received a Dipl. Ing. and a M.S. degrees in communication and electronic engineering in 1980 from the University of Iassy and a Ph.D. degree in telecommunications from "Politechnica" University of Bucharest, Romania in 1991, and a Master in Applied Mathematics in 1998 from the University of Colorado at Boulder. From 2002 to 2008 he was with the Department of Electrical and Computer engineering at the University of Texas at San Antonio (UTSA). From 1984 to 2001, he was with the Department of Electrical Engineering, University of Iassy, where he conducted research and teaching in the area of digital communications as a Full Professor at the same department. Since 2008, he has been with the University of the District of Columbia as an Associate Professor. He has authored or coauthored more than 100 papers in these areas and 4 books. Dr. Paul Cotae is a Senior Member of IEEE, member of ASEE, member of HKN (Eta Kappa Nu) and SIAM. He is cited in Who's Who in American Education, Who's Who in America, and in Who's Who in the World. Dr. Paul Cotae is Vice Chair of the IEEE Washington Section, Chair of the Communication Chapter Washington Section. He is the recipient of the 2011 IEEE ComSoc Chapter Achievement Award and 2011 IEEE ComSoc Chapter of the Year award. He has been selected as ASEE Fellow by the Naval Research Laboratories in 2009 and 2010.

# Detecting Falls among Elderly Patients in Nursing Homes by Using Wireless Sensor Networks

## ABSTRACT

Accidental falls among the senior population are the leading cause for seniors' admission to hospitals. Wireless Sensor Networks (WSN) can be used to efficiently detect falls of senior patients in nursing homes. While some fall detection methods focus on the acceleration of the patient, others register acceleration and body position to detect falls. In this paper, we describe a novel alert system using WSN capable of detecting falls based on the body position and bed occupancy. The system was created according to data collected in MoteView from seven test subjects. Accordingly, it was designed to sense three possible conditions: (1) patient being active; (2) patient lying in bed; or (3) if the patient has fallen down. The experimental portion of this research was performed at a nursing facility to further validate measurements previously collected in the laboratory. Furthermore, the system has been tested on three subjects for different types of falls and was found to detect all types of falls with high accuracy. In order to provide caregivers with constant alerts regarding patients' conditions a graphic user interface was created in LabView. Design of this system maximizes the capabilities of Memsic's Wireless Sensor Network Developmental Kit consisting of MICAz and MIB520 base station. Overall, the system provides a very simple and effective solution that yields high accuracy for detecting falls.

## I. Introduction

Accidental falls represent a major issue in nursing homes. According to the Centers for Disease Control and Prevention, on the average there are 100 to 200 reported falls each year in nursing homes with 100 beds<sup>[1]</sup>. Accidental falls among elderly have massive socio-economic impacts. Most elderly patients admitted to hospitals are victims of falls. Accidental falls are among the primary cause of death among the elderly. Furthermore, falls might seem not to have immediate consequences but the long-wait on the floor can increase the risk of death. Thus, falls detection and real-time monitoring to enable first-aid as quick as possible is urgently needed in nursing homes and other elder care facilities.

The issue of accidental falling can be vastly improved through the use of sensors which monitor patient activities and remotely communicate any and/or all information to attending physicians or caregivers in charge. For instance, sensors placed on a patient's body and/or around the patient alert caregivers immediately upon the occurrence of a fall. There is substantial research available in the field of fall detection. Qiang Li<sup>[3]</sup> has classified this research in two categories. The first class analyzes only acceleration for fall detection and the second class uses both acceleration and body orientation to detect falls.

In this paper, the system is based on a Wireless Sensor Network that continuously monitors and analyzes a patient's movement. Our method is created in such way where it maximizes the capabilities available through the Memsic Wireless Sensor Network Starters Kit. A dual axis accelerometer is used which is placed on the test subject's chest. Another sensor was placed on the patient's bed which informs of actual occupancy. Our system is based on the logic that if the patient is in not in a horizontal position and the bed is unoccupied, then the person has fallen down. This approach is characterized with simplicity and accuracy in determining falls. Finally, we have designated a software interface to process and analyze data and report emergency situations to the monitoring station. The remaining parts are outlined as follows: Section II provides detailed information on the network's hardware; Section III presents the method and

measurements; (3) Section IV underlines the software interface, and Section V is the conclusion and further development.

## II. Hardware implementation:

### A. System Architecture

For this research, we have worked on one of the MICA platform called MICAz Mote. This work is composed by a set of MICAz Motes with IRIS OEM module (M2110). The MICAz is a 2.4 GHz Mote module used for enabling low-power wireless sensor networks. MICAz is used to test for Light, Temperature, RH, Barometric Pressure, Acceleration/Seismic, Acoustic, and Magnetic based on the sensor/data acquisition board. These motes have a radio transceiver, a microcontroller, a sensor board (MTS400CC) and power supplied by double AA batteries. The microcontroller is an 8-bit ATmega 1281 which contains and runs the firmware which implements the 802.15.4 specification. The sensor board MTS400CC has a set of three sensors: The Accelerometer, Light sensor, and Temperature sensor.

MoteView was designed to be the primary user interface between a user and a deployed network of wireless sensors. MoteView provides an easy means of logging wireless sensor data to a database, analyzing, and plotting sensor readings. Data presented in Figures 4, 5 and 6 have been exported from Moteview to Excel.

### B. Hardware Components

Figure 1 presents the hardware connections and network topology used in this work. One of the Motes works as a base station and it is attached on the station called MIB520. The base station is connected to the PC via USB adapter and allows the aggregation of sensor network data onto the PC. The sensor nodes collect data (light, acceleration etc.) from the environment and send this data directly to the base station which in turn forwards it to the computer within every user defined time interval.

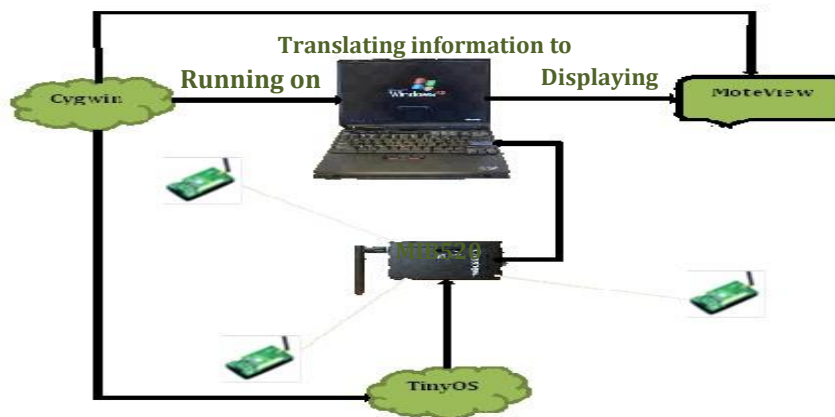


Figure 1. Hardware connections and communications of MICAz

## III. Algorithm and Measurements



As mentioned in introduction we will use Memsic WSN to detect 3 different **situations**: if **patient is active**, if **patient is lying in the bed**, or if **patient has fallen down**. These situations are outcomes of 4 different **events**: **patient torso is in upright position**, **patient torso is in horizontal position**, **bed is occupied**, **bed is not occupied**. Depending of the joined outcomes of these events we can determine which one of previously mentioned situations has occurred. This logic is displayed in Table 1.

In order to record first two events (patient torso in upright or horizontal position ) we have placed MICAz sensor node on the chest of the patient. MICAz has MTS400CC sensor that is equipped with Dual-axis Accelerometer ADXL202JE. We have placed the sensor on the chest of the patient in such way that positive y-axis is going towards the ground, and x axis is perpendicular to in and parallel to the floor. According to the Figure 2, the orientation of the sensor node varies with the body position of the patient. The ‘x’, ‘y’ and ‘z’ are acceleration axis which represents the orientation of the wireless sensor on the patient. Even though the wireless sensors we are using in this project have acceleration only in ‘x’ and ‘y’ direction, we included z axis in the above diagram for better visualization of the orientations of the sensors. When the patient is standing, positive y axis is going straight to the ground so in that event we have recorded acceleration of  $Acc_y \approx 10m/s^2$ . When patient is laying y axis is parallel to the ground  $Acc_y \approx 0m/s^2$  as illustrated in Figure 2.

Despite limited daily activities of nursing home patients, we studied all possible activities that normal elderly patients would do. For each activity we have recorded accelerations in y axis. We had seven different sample data from seven (7) different individuals have been collected. Even though our study is about fall detection of patients in nursing homes, studying the whole possible body movement of patients is very important to draw a distinction line between a fall and all other activities of patients. List of patient activities studied: (1) walking; (2) walking with cane; (3) standing straight; (4) lying on the back; (5) lying on left side; (6) sitting; (7) running; (8) sitting and watching TV; (9) tying shoes; (10) lying on the right side; (11) eating from a table; and (12) sitting on the bed.

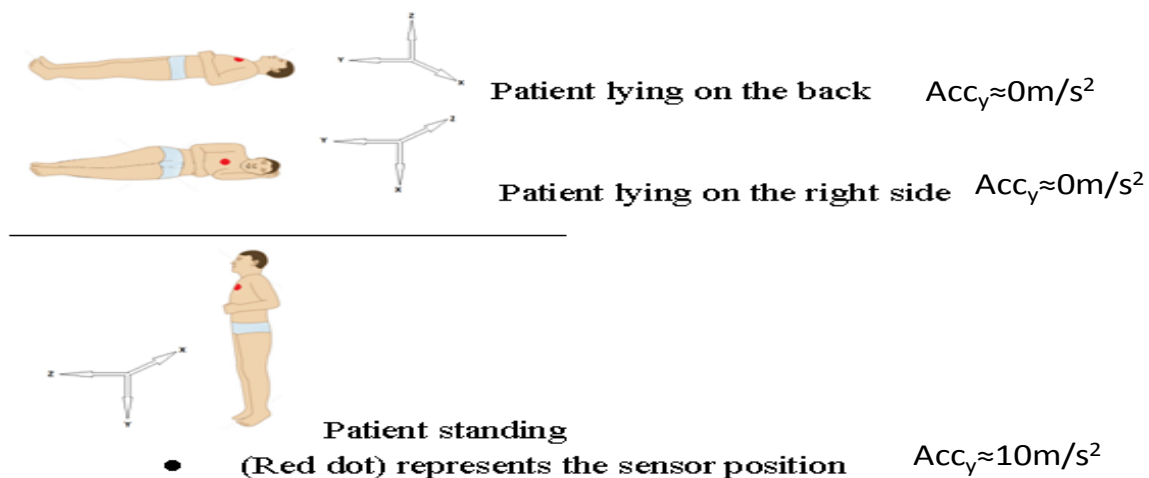


Figure 2. Axis orientation of bi-axial accelerometer which is placed on the patient

Table 1: Fall Detection Depending on 4 events

<b>IF <u>the position of patient torso IS</u></b>	<b>AND IF <u>the patients bed IS</u></b>	<b>Then <u>the situation IS</u></b>
Upright	Occupied	PATIENT ACTIVE
Upright	Unoccupied	PATIENT ACTIVE
Horizontal	Occupied	PATIENT IN BED
Horizontal	Unoccupied	PATIENT HAS FALLEN DOWN

The above list of activities has been demonstrated by seven subjects for certain fixed duration of time allocated to each activity. The graph of acceleration in y axis for all subjects is similar and one example is shown on the Figure 3.

According to Victorian Government health information, fall is unintentionally coming to the ground or some lower level and other than as a consequence of sustaining a violent blow, loss of consciousness, sudden onset of paralysis as in stroke or an epileptic seizure. In this paper a fall is detected by the position of the patient’s body using wireless sensors. As the last position of body in the case fall is horizontal in line with the floor or lower level the patient fall on, horizontal position of a body means a fall according to the data from the wireless sensors.

After careful analysis of our data we have concluded that when body is in horizontal position acceleration in ‘y’ axis is always ranging between  $-4\text{m/s}^2$  and  $+4\text{m/s}^2$  and any other activities previously mentioned on this paper gives acceleration over  $7\text{ m/s}^2$ . Example of this can be seen in Figure 3. Values of acceleration are shown in Table 2.

**TABLE 2: Body position determined from sensor acceleration in y-axis**

Acc <sub>y</sub> (acceleration in y-axis)	Body position
Acc <sub>y</sub> > 7 m/s <sup>2</sup>	Patient in upright position (patient active)
Acc <sub>y</sub> < 4 m/s <sup>2</sup>	Patient in horizontal position (patient laying)

Furthermore different ways of falls have been studied and our threshold has been tested on 3 individuals. All falls have been recorded and we didn’t have any falls alarms. The graph for patient falling from a bed as in Figure 4 and falling from standing position are shown as in Figure 5.

Having a clear distinction line between lying down and other activities, the next step is to distinguish between a lying on the bed (normal sleep) and lying on the ground (falling). Since both lying on the bed and lying on the ground assumed to result in horizontal body position, there should be a mechanism to distinguish between lying on the bed and lying on the ground which will be discussed next.

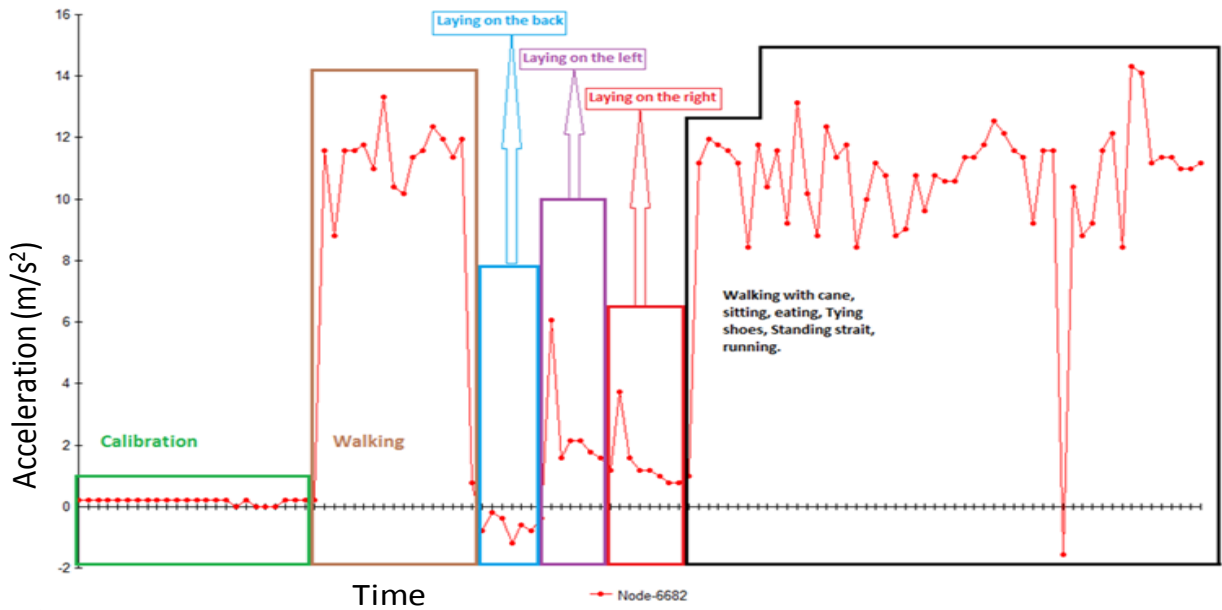


Figure 3. Acceleration in Y-axis of One Test Subject for Various Activities.

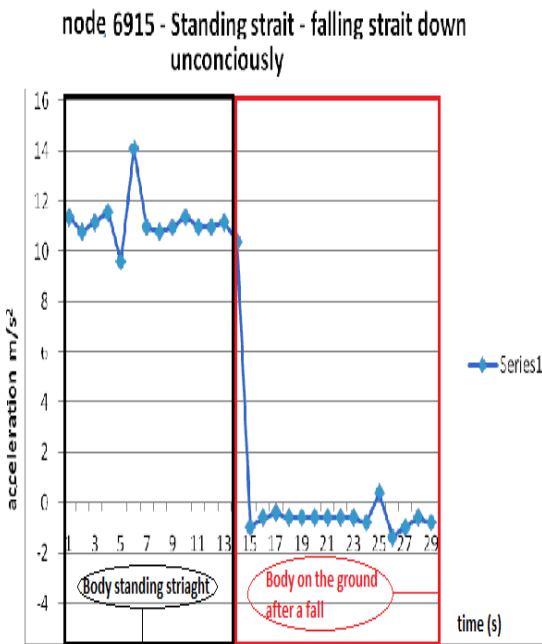


Figure 4. Falling to the ground from a standing body position

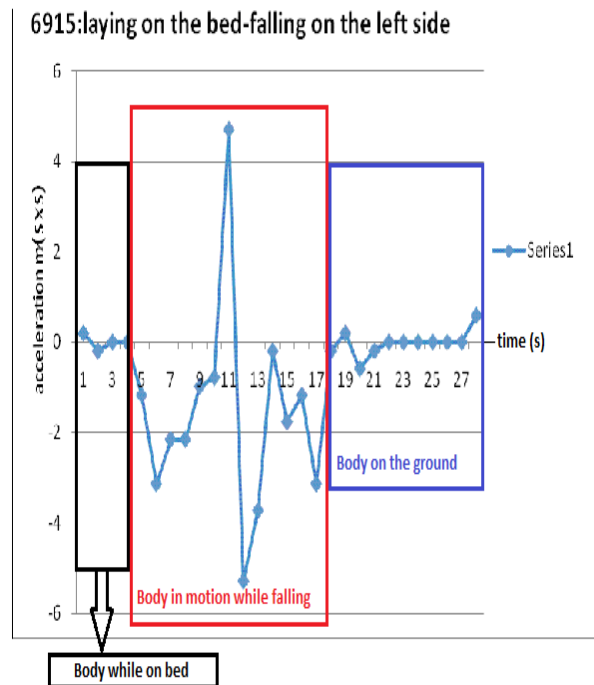


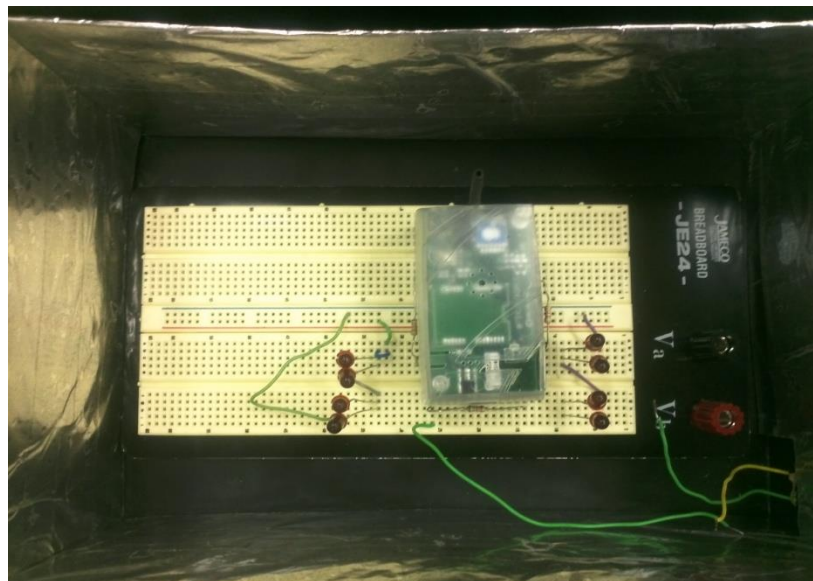
Figure 5. Falling from a bed to the ground

### III B System developed to distinguish between lying on the bed and on the ground

As mentioned previously, first node that is placed on patient chest is determining if patient is active (in vertical position) or lying (in horizontal position). When patient is horizontal position, second system will help us to differentiate between laying on the ground (which is a fall) and

lying on the bed which is assumed to be sleeping (not a fall). Schematic of this system is shown in Figure 7.

Switch placed on the bed of the patient is used to detect the occupancy of the bed. Once the patient lays on the bed, he will depress the switch connected in DC circuit with 4.5V battery in 8 LED lights. Led lights are placed in a box that is constructed from opaque material to prevent light coming from outside, and in such way only the light that is coming from the LED lights is controlling the light intensity in the box. MICAz node is placed in the box and it is sending light intensity data to MIB520 base station. If the light intensity is under 1Lux, that is a signal LED's are not emitting light and that bed is not occupied. If light intensity is above 10Lux that is a signal that LED's are emitting light and that bed is occupied. So now we have all necessary technology to determine 4 events that will tell us if patient is active, if patient is laying down or if patient has fallen down. Once again this logic was displayed in Table 1.



**Figure 6: Device for detection if bed if occupied.**

#### IV. Data processing and creation of alerts in software with user interface

In this part of the project we have used a program to process the data that are received from Memsic WSN. Software used is Labview2010. LabVIEW is a graphical programming environment that is used to develop sophisticated measurement, test, and control systems using intuitive graphical icons and wires that resemble a flowchart.

In the current stage of this research there are two graphical user interfaces created. In the first interface LABVIEW receives data from Memsic WSN and MICAz node that is placed on patient chest, and then it compares values from acceleration in y-axis with our set thresholds. Depending on those values, two alerts are possible: patient is in laying ( $y_{acc} < 4m/s^2$ ) or patient is active ( $y_{acc} > 7m/s^2$ ). This front panel can be seen in Figure 7. Furthermore these values have been coupled in two consecutive time intervals ( $y_{acc}(T)$ ,  $y_{acc}(T+1)$ ) in order to get more accurate information. Second graphical user interface has been created for data received from node that detects bed occupancy. If flux is under 1lux that there will be an alert that bed is unoccupied. If Light flux is above 10 Lux second alert will prompt that bed is occupied. Front panel for these values can be seen in Figure 8.

Development of this program had several stages. First we had to acquire third party drivers<sup>[4]</sup> for communication between crossbow and LABVIEW. These drivers weren't provided by National Instruments. Schematic (block diagram) that was made premade this 3<sup>rd</sup> party software had to be

optimized for our sensor board. Board MTS300 was changed to the board MTS400. Wiring and array had to be changed so we could manipulate with the data. Finally, we made thresholds, and made warnings on front panel.

Next stage of this research project will focus on creating a LabVIEW graphical user interface with capabilities of processing data from two nodes simultaneously. Once that is achieved, there will be one interface that will present three alerts: patient is active, patient is in bed, patient has fallen down. The Logic of this process in Labview is shown in Flowchart 1.

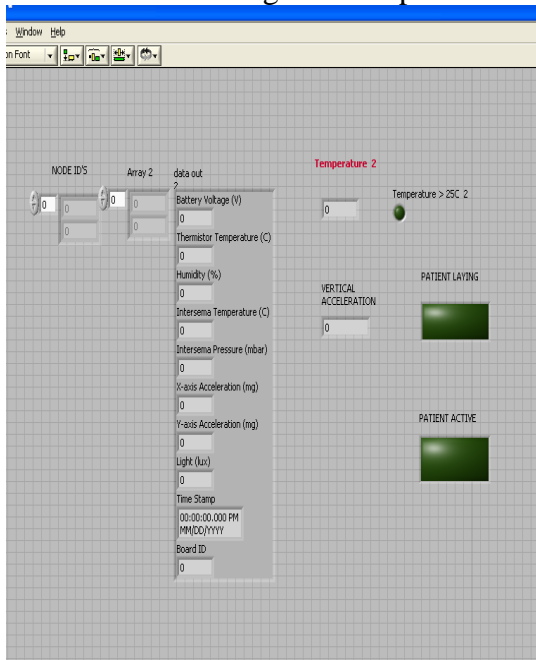


Figure 7. LabVIEW graphical user interface showing patient position.

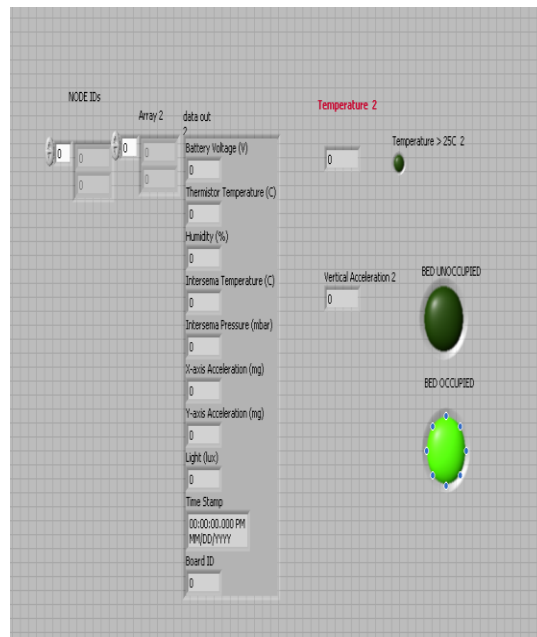
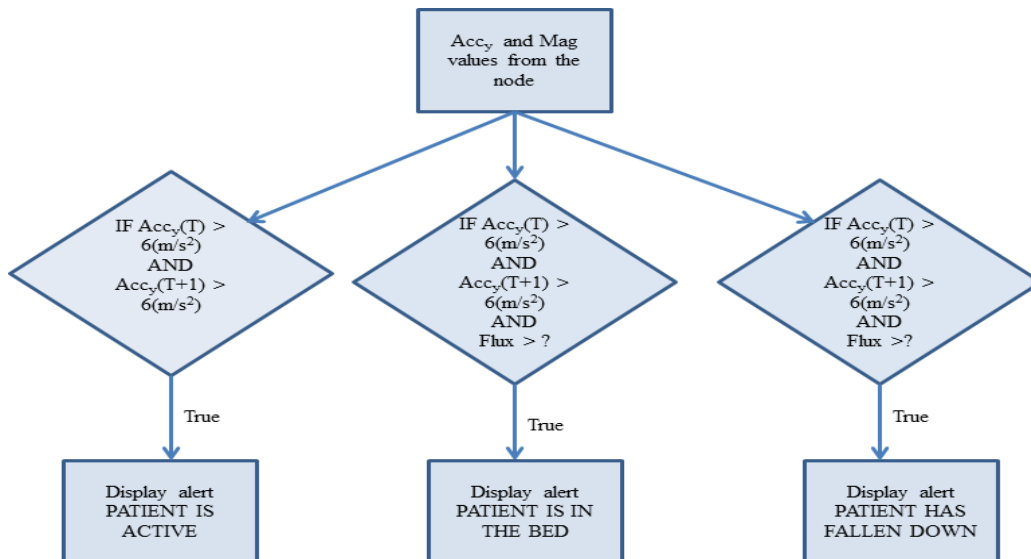


Figure 8. LabView graphical user interface showing bed occupancy.



Flowchart 1: Algorithm in LABVIEW

## V. Conclusion and Future Work.

Accidental falls represent serious issue among the senior population. Timely detection of these events in nursing home significantly improves treatment of injuries and reduces costs to healthcare system. The aforementioned paper is a clear demonstration of a simple and effective Wireless Sensor Network (WSN) system which detects senior patients falling in nursing homes. Behavior of senior patients was observed in nursing home and used to create list of possible activities that senior patients engage in daily activities. Then the system was created based on data from seven test subjects, and then system capabilities were verified on three test subjects. System has detected every fall, and didn't have false alarms.

In further research we will concentrate on creating user interface that will be able to simultaneously process data acquired from two nodes and provide care givers with alerts about conditions of patients. Also, we are developing circuit with 555 timer that will prolong life of our 9V battery. Furthermore, there is an idea to use MTS420 sensor board equipped with GPS tracking device that will provide inform us not only about condition of the patient, but also with their accurate position.

## VI. Acknowledgements

This research was supported by the Office of Naval Research, Department of Defense Grant W911NF-11-1-014.

#### Bibliography:

1. Stefano Abbate, Marco Avvenuti, Paolo Corsini, Janet Light, Alessio Vecchio, “Monitoring of human movements for fall detection and activities recognition in elderly care using wireless sensor network: a survey”, *Intech*, December 2010, pp 1-5.
2. Center for Disease Control website  
<http://www.cdc.gov/HomeandRecreationalSafety/Falls/nursing.html>
3. Qiang Li, John A. Stankovic, Mark A. Hanson, Adam T. Barth, John Lach, “Accurate, Fast Fall Detection Using Gyroscopes and Accelerometer-Derived Posture Information” University of Virginia. *Wearable and Implantable 2009*, BSN, Sixth International workshop.
4. How to Install a Crossbow MIB520 Base Station. National Instruments web site.  
<http://digital.ni.com/public.nsf/allkb/>
5. IEEE. (2011) IEEE *Xplore* Digital Library. Available: <http://www.ieeeexplore.ieee.org/>
6. Wikipedia, “Sensor Node” [Online], Available : <http://en.wikipedia.org/wiki/Motes>
7. Memsic. (2011) The Memsic Solution. Memsic. <http://www.memsic.com/>
8. Cygwin DLL Red Hat [Online] Available: <http://www.cygwin.com>
9. TinyOS Technology Exchange UC Berkeley : [www.tinyos.net](http://www.tinyos.net)

## **Now That Computers Are Here, What Do We Do In Lab?**

DONALD D. JOYE  
Department of Chemical Engineering,  
Villanova University, Villanova, PA 19085

DONALD D. JOYE

Dr. Joye has been at Villanova for 30 years and counting. He graduated from Princeton University (B.S.E. 1967) and did graduate work at Lehigh (M.S. 1969, Ph.D. 1972). His major interests are in Fluid Mechanics, Heat Transfer, Mass Transfer, Polymers and Rheology. He has five years industrial experience with Sherwin-Williams Chemicals, Engelhard, and Hercules, Inc. doing process engineering, patents, and process R&D. He has headed the laboratory program in chemical engineering at Villanova for almost 15 years and has over 40 research publications.



## NOW THAT COMPUTERS ARE HERE, WHAT DO WE DO IN LAB?

### ABSTRACT

Focused on Chemical Engineering, the following paper is a discussion of strategies and coping mechanisms for the onslaught of virtual laboratories many people are advocating for replacing the traditional lab experience, which includes coming to grips with large scale equipment used in the process industries. Yet, we also acknowledge the usefulness of computer data acquisition and the like as desirable for the modern experience in lab, because this is the way industry now does it, more or less. However, experience with real equipment and its operation is invaluable to the engineer, should never be lost as part of the educational process, and cannot be reproduced by “virtual” laboratory experiences, useful though some of them may be. Another compelling reason for hands-on experience in laboratory is preparation for research. This is often overlooked in these arguments, but lab can be a place where the student makes up his or her mind that research may be interesting or not interesting to pursue. In my own personal experience I can remember one lab in particular that was not particularly exciting, but stirred my interest in research, because it was set up like a research project. Similar anecdotal stories have bubbled up from our students in my teaching experience at Villanova and elsewhere.

In our laboratory sequence we have tried to balance these often conflicting trends. Our program has had and still has an orientation toward chemical engineering practice, so giving up large-scale equipment has been keenly felt. Integrating the computer has not always been productive or relevant. And because of rapid electronic obsolescence, whatever computer arrangement one has, has to be re-done in 5-7 years. This is an enormous challenge to those of us who run the lab. For example, who does programming any more?

In what follows, the evolution of lab at Villanova’s chemical engineering department is discussed with a view toward clarifying these issues. Some decisions need to be made, and schools will make them differently, depending on what they want lab to be.

### Development

Thirty years ago, lab consisted of hands-on experiences with various pieces of equipment, large and small. A full formal report was required for each. Twelve or so experiments were given each semester – the lab sequence was two semesters. No computers were used.

Over the years, many changes have come to lab. With these many experiments, students did not have enough time to do the experiments with the larger pieces of equipment, and their work was often sloppy and incorrect. Report writing was so bad that we instituted a new first lab to focus mainly on that. The experiments used were much simpler. In the remaining two labs, the first (junior lab) was given over to what one department chair called “analysis of principles” experiments, which were done on relatively simple pieces of equipment and were strongly related to specific situations covered in course work. In some cases they supplemented course work. In the senior lab, larger pieces of equipment were used – for example, a semi-works level double effect evaporator, a large distillation column with 20 stages (this is three stories high and about two feet in diameter), a tray drier, some miscellaneous heat transfer experiments including radiation, a packed gas absorption column and the like. Over time, some of these experiments were replaced with skid-mounted, packaged experiments. These are table-top mount and about 4 feet by 6 feet vertical board space with equipment mounted on the board. In the rest, the equipment was repaired, serviced and otherwise maintained and refined. A computer-based simulation was added consisting of an in-house program for simulating chemical reaction.

Students still could not complete these labs in one three-hour session, so consequently we went to two three-hour sessions and increased the credit accordingly. Originally labs only counted for one credit – a situation that students universally complained about, because it appeared they did much more work than they were getting credit for. We also added a supervised calculation session to improve the analytical part of the exercise.

Then the computer part of the lab fell on hard times, and we decided to buy a packaged unit for chemical reaction. This came from Jordan Spencer's line of lab experiments for chemical engineering<sup>1</sup>, first offered by Feedback, Inc. and later from Perfected Experiments. We also bought (not at the same time) his ammonia absorber, another packaged unit. Both of these have worked well in lab, after a little tweaking. Several other companies offer skid-mounted lab exercises that look quite useful for laboratory<sup>2-5</sup>, for example).

Relatively recently, we have added a new pumps lab that is set up for computer data acquisition and included a laptop and protocols for running the experiment. So far, this has worked well, and has encouraged our thinking along those lines. One of the advantages of the new setup has been the elimination of mercury manometers from that experiment and substitution of electronically calibrated rotameters for flow rate.

Also, we have been aggressively looking for a glass walled, continuous distillation column. We priced this out from various suppliers (all of which had very attractive units), and we were shocked at the average price of \$100,000. Who has money like this? This had all the electronic data acquisition and professional design components that argued for quality and convenience. However, the price was a deal-killer. So there are practical limits to converting all the equipment to computer data acquisition.

Other departments at Villanova have come to grips with these common problems in their own way. Electrical Engineering is not bothered by large equipment, and they have been at the forefront of computer applications in lab, and so they have not experienced the same kind of problems that others have. Both Civil and Mechanical Engineering have some need for large-scale equipment and modern computer data acquisition. Civil Engineering now has their own lab building, and Mechanical Engineering will soon have their equivalent. In both cases, large-scale equipment and computer data acquisition will be part of the picture. Because of the computer part of this, each of these departments has their own, dedicated expert for computer interfacing, so that the equipment can be maintained in tip-top condition. By contrast, most chemical engineering departments are not large enough to have a sufficient budget to cover this need; consequently we have more difficulties with this approach.

In another effort to address lab experience earlier in the curriculum, Villanova has followed the Notre Dame example<sup>6</sup>, adapting it to unique situations at our site<sup>7,8</sup>. In each semester of the freshman year, students have a choice of experiments to sign up for. One is usually close to the field they will major in and one outside it. There are six experiments they can select from, and they are mostly bench-scale. Two faculty members, each from a different department, supervise and guide the experiments. Student response has been overwhelmingly positive, so hands-on work is a significant motivator for engineering students and is another reason for keeping some experience like this in the program.

At Villanova, our program has a practical emphasis, even though we are moving more and more into a greater research orientation. So, lab needs to do a lot of different things. This is not easy, and some things cannot be done for various reasons, money being one of them, space another. We are not set up to do labs in courses, though some schools do that as a way to get the simpler lab experiences before the students.

## Education

What is it that we want to do in lab? It turns out different schools have different thoughts about this. Some have converted to small experiments all of which are run off the computer. Some, like us, have tried to maintain a semblance of large equipment experience in at least one lab course. Some have converted to total computer simulation experiments. What to do?

We might begin by asking the question “what is lab for?” In this author’s opinion, lab is for hands-on experience with equipment. Therefore, I would not vote for total computer simulation, though some of these may be interesting. Lab equipment does not all have to be large-scale. In fact, some smaller scale experiments can be set up like research projects and can be a way to introduce or encourage students to think about research and/or graduate school, as happened to me in my undergraduate experience. This lab was a mass-transfer lab where the rate of sublimation of a naphthalene mothball in an air stream was studied<sup>9</sup>. The lab was not particularly exciting (it was kind of like watching sand dry), but the way it was set up and the analysis comparing theory to data caught my interest. The agreement was fairly good, and I saw a use for theory and a use for testing theory with experiment.

Since I’ve had significant full-time industrial experience, in addition to consulting and summer jobs, I am convinced that the use of some large scale equipment is necessary for a good education in practical chemical engineering. It takes a little bit for a student to get comfortable with the scale of some engineering jobs. Civil and Mechanical engineers also have this challenge. I worked with such equipment directly and indirectly in many of my assignments in the chemical process industries. Because of my experience with lab, I could see the good and the bad of industrial practice. In some cases, processes were textbook; in others, one couldn’t even find a thermometer to measure temperature where it should have been measured. Not all processes had computer control or data acquisition. If industry doesn’t see a need, they don’t use it. Simple. Exposure to the industrial mind-set is something student engineers ought to be introduced to before they get there. In one, very focused work, Fogler<sup>10</sup> describes a senior lab experience dedicated to developing troubleshooting skills, which necessitates large-scale equipment. This is quite valuable but very time-consuming.

Another facet of laboratory learning that has almost disappeared is the coming to grips with getting the equipment to work right by yourself, independently. You’ve studied it in class, now make it work. This is not a cookie-cutter exercise and also takes a lot of time. Sometimes students spent six hours in a three-hour lab to do it. But you learn things beyond the textbook. Because of modern time constraints on lab and other issues, we can no longer afford to do much of this, and it’s a loss for preparing our students for real work experience.

## Conclusions

In conclusion it should be recognized that some schools are going to do it their own way regardless. That’s the diversity in our educational system. But all choices have consequences, and it’s probably not practicable to be all things to all people.

Too much reliance on the computer gives a distorted picture of real engineering in some disciplines.

Hands-on experiences are very significant for student motivation and introduction to real-world operations, and are and should continue to be an integral part of any engineering program.

## References

1. Jordan Spencer, *Perfect Experiments*, 2008.
2. Armfield, *Engineering Teaching and Research Equipment*, 8<sup>th</sup> ed
3. Hampden Engineering Corporation, *Chemical Engineering Systems*.
4. PIGNAT, *Modular Kilolab Equipment*.
5. U.S. Didactic, *Educational Equipment and Training Systems*.
6. Brockman, J.B., *Introduction to Engineering: Modeling and Problem Solving*, J. Wiley & Sons, NY, 2009
7. Dinehart, D., Gross, S., Yost, J., Radlinska, A., "The Role of Structural Engineering in Multi-Disciplinary Freshmen Projects", ASEE 2010 Annual Conference, Louisville, KY, June.
8. Caverly, R., Fulmer, H., Santhanam, S., Singh, P., O'Brien, J., Jones, G., Char, E., Mercede, F., Weinstein, R., Yost, J., "Project-based freshmen engineering experience: The Core Course," 2010 ASEE Annual Conference, Louisville, KY, June.
9. Welty, J.R., Wicks, C.E., Wilson, R.E., *Fundamentals of Momentum, Heat and Mass Transfer*, 3<sup>rd</sup> ed., J.Wiley & Sons, NY, 1984. pp. 624-626.
10. Fogler, H.S., "Using the Senior Unit Operations Laboratory to Develop Troubleshooting Skills and to Ease the Transition to the Work Place," *The Academy of Chemical Engineers Lectureship*, U. Missouri-Rolla, 2003.

# **A Visiting Associate Professor's Collaborative Research Experiences among Students, Faculty and Industry, for a Hand Opening Assistive Device (HOAD)**

## **HOAD Research Group, P. I.**

**Edward M. Land:** Appointed Faculty Member, Johns Hopkins University, School of Medicine

## **Visiting Associate Professor**

**Michael Marcus:** Penn State University – York Campus

## **Student Research Assistants:**

**Aaron Abugaber, Rohit Dayal, Noah Greenbaum, Sally Hong, Jon hunt, Joseph Saltzman**

Affiliation: Johns Hopkins University, Whiting School of Engineering – Homewood Campus

EDWARD M. LAND holds a faculty appointment at JHU, SOM as a Consulting Engineer, Principal Investigator and Instructor to PM&R, HOAD Research Group. Taught Advanced Assistive Device Technologies to BME, MechE, EE undergraduate and graduate students for 14 semesters. Serves as an invited judge, Whiting School of Engineering and SOM for CBID Medical Device Developments. Ed holds a BS from UMUC and 18Cr Hrs at the MS level at UMUC – College Park, MD Campus.

MICHAEL MARCUS is a Visiting Associate Professor, for Advanced Assistive Devices, in the Johns Hopkins School of Medicine. He worked in industry for 17 years in the Biomedical Instrumentation field as a Senior Project Engineer where he designed and submitted biomedical instrumentation to regulatory agencies. He is currently an Associate Engineering Professor at Penn State University - York Campus.

AARON ABUGABER is a Mechanical Engineering Senior at Johns Hopkins University. He is the senior most student Research Assistant member of the HOAD project, having worked on it since his freshman year. He is currently working on the CAD designs for the active device and is an integral part of the development and design of these components.

ROHIT DAYAL is a Senior in Biomedical Engineering & Applied Mathematics at Johns Hopkins University. He has devoted his time to determining the necessary steps required for the devices to meet FDA approval. Additionally, he developed an external Portfolio for HOAD that provides an overview to the general public which complements the two (2) US and two (2) foreign Patent Applications that were filed on July 7<sup>th</sup> 2011.

NOAH GREENBAUM is a Junior in Biomedical Engineering & Electrical Engineering at Johns Hopkins University. His experience in electrical engineering has been a valuable asset from the onset of this summer 2011. Through his hard work, preliminary models of the Arduino circuit to be implemented in the active device have now become a reality.

SALLY HONG is a Sophomore in Biomedical Engineering at Johns Hopkins University. Sally has looked into the funding opportunities to sustain HOAD and its immense progress. She has researched extensively and assembled an informative Comparison Chart on competing hand-assistive products. Sally has identified 24 Predicate (or prior art) devices which have contributed significantly to the pool of hand assistive devices.

JON HUNT is a Sophomore in Biomedical Engineering at Johns Hopkins University. He joined the HOAD project this summer as a volunteer, but has played a pivotal role in converting all written materials from the past 6 years to a consistent electronic format. Jon has also identified a source of single breathable, wickable material whose outer layer is also hydrophobic. This fabric is needed to complete the shell of our medical glove.

JOSEPH SALTZMAN is a Senior in Mechanical Engineering at Johns Hopkins University. Over the past three years, he composed four research papers for the HOAD project team. The format of his term papers has become the standard for others to follow.

# **A Visiting Associate Professor's Collaborative Research Experiences among Students, Faculty and Industry, for a Hand Opening Assistive Device (HOAD)**

## **HOAD Research Group, P. I.**

**Edward M. Land:** Appointed Faculty Member, Johns Hopkins University, School of Medicine

## **Visiting Associate Professor**

**Michael Marcus:** Penn State University – York Campus

## **Student Research Assistants:**

**Aaron Abugaber, Rohit Dayal, Noah Greenbaum, Sally Hong, Jon hunt, Joseph Saltzman**

Affiliation: Johns Hopkins University, Whiting School of Engineering – Homewood Campus

## **Abstract**

For the past year I have experienced working on a research project, as a Visiting Associate Professor, at the Johns Hopkins University, School of Medicine. This paper will describe the nature of my appointment, the course structure, personal contributions, how the project is documented using Dropbox, and the collaborative relationships within the university and industry, for a Hand Opening Assistive Device (HOAD) that is in its fourth year of development. This paper will describe the two types of HOAD medical devices under development and their intended use as rehabilitative appliances. In addition, the interaction of how graduate and undergraduate students have participated on this team over the semesters, taking the course for credit or as volunteers, to gain the experience of working on a team lead by an Engineer with many significant years of industrial experience. The steps in the project development will be described along with the contributions of various team members and how their work was evaluated. The regulatory aspects of this project will be described along with how an on-going search is made for competitive devices. Finally, the future direction for this project including: next generation developments, partnering with the Veterans Administration, other educational institutions, selecting manufacturing facilities and setting up future supply chain distribution will be presented.

## **1. Introduction (By Michael Marcus)**

As an Associate Professor of Engineering at Pennsylvania State University, York Campus, I have worked with students on design projects for various courses that I teach. In addition, I have published in the area of teamwork that is based on my 17 years of experience as a Senior Project Engineer in Biomedical Instrumentation field.<sup>1,2</sup> As an instructor, I have program specific knowledge of how Capstone Projects work. As a researcher, I had little knowledge of how major Research Projects function that include Faculty, Undergraduate, Graduate Students, and their relationships with Industry. I had the opportunity this past year to collaborate with EDWARD M. LAND, the HOAD Research Project P. I. of the Hand Opening Assistive Device (HOAD) Research project from Johns Hopkins University.

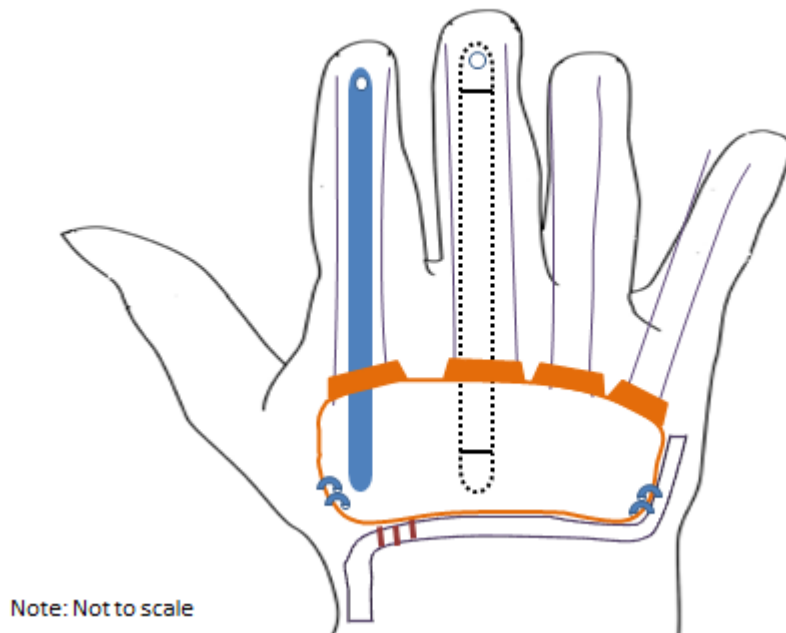
Ed is a Consulting Engineer, for the Advanced Assistive Device Technologies Class that he teaches at the Johns Hopkins University, Whiting School of Engineering through a jointly sponsored agreement with their Biomedical Engineering Department. After describing my

background, that included designing and submitting biomedical instrumentation to regulatory agencies, and my desire to become involved in the interesting project that he is heading, I offered my services to participate on his research effort. I submitted my Resume to the Advisory Board of the School of Medicine Faculty at JHU and was appointed as a Visiting Associate Professor, in the Department of Physical Medicine and Rehabilitation, Pro bono, working part time.

I will summarize my contributions to this program under the following topic areas: a) working with students to develop microprocessor software and driver electronics to control an active Hand Opening Assistive Device; b) working with students to determine which of the FDA guidelines and procedures would lead us to an FDA approval. c) Additionally, I worked with students on how to use a data acquisition system to obtain finger force measurements.

## **2. Research Area – HOAD Research Group. (By Edward Land)**

Our unique, light weight and comfortable, low-profile hand-assistive ‘glove-like device’ is designed to serve as a rehabilitation, splint or exercise appliance. The device provides finger extension assistance for individuals who lack hand-extension ability as a result of stroke or other neurologic trauma, see Figure 1. Our research team has already developed a one-off, proof-of-concept, electrically powered, assistive device and has produced three mock-up versions of our passive (spring-assisted), hand-extension prototype. An articulating thumb assembly is currently under development for both passive and active styles. Each ‘glove’ is designed to be easily adjusted or modified to produce a ‘best-fit’ that is to be available in different sizes and customized to accommodate each client’s precise needs while holding inventory to a minimum. Each glove-like device shall be capable of extending (or exercising) the closed fist of a particular class of stroke, accident victim or returning war fighter.



**Figure 1. Top View of Actuator Blades into Glide Plate Stack**

## **2.1 Project Team (By Edward Land)**

Traditionally, we look for students who enjoy working with others in synergistic relationships. Each semester (for the past 14 semesters) we (HOAD Research Group) have actively recruited biomedical engineering (BME) student research assistants under a joint venture agreement with the Whiting School of Engineering (BME Dept) located at JHU's Homewood Campus. Two semesters after having established a successful BME track record, we began recruiting much needed mechanical engineering (MechE) RAs, and beginning summer semester 2011, electrical engineering (EE) candidates.

All research assistants (RAs) learn to perform basic and applied research and the importance of conducting peer reviews in order to benefit from lessons learned. HOAD Research recruits both volunteers and credit seeking students. The recruiting process is coordinated with the assistance of each department's engineering registrar and each student's advisor or sponsor. Classes for credit seeking students are capped at eight credit seeking students. Students report that they enjoy tracking down prior art (predicate) devices, discovering the potential benefits through testing and using new materials and processes during lab periods. Our team carefully evaluates leading edge device technologies, processes and competitive designs for consideration as our passive and active designs mature. New inductees learn from other RAs who in some cases, have been with HOAD for a number of semesters. Our ever changing core of seasoned RAs eagerly takes on the responsibility of offering their assistance to new students.

Additionally, a few students enjoy taking on stretch assignments such as: learning Computer Aided Design or being able to assist new RAs to learn about CAD design and rapid prototyping. Summer semester 2011, we had a total of eight students (four volunteers and four credit seeking) and for fall 2011 we have a total of eleven students, two of whom are seeking credit. We offer opportunities to earn up to three (3) credit hours. Unfortunately, undergraduate applicants are ineligible to receive compensation in lieu of credit.

## **2.2 Background and How Selected (By Edward Land)**

HOAD Research Group was officially chartered in August 2006 as a Johns Hopkins, School of Medicine (SOM), PM&R enterprise to develop affordable, low-profile, comfortable and light weight, hand extension, glove-like devices capable of opening the closed fist of a stroke victim or other person unable to open their affected hand. Co-inventors of the group consist of two engineers, three scientists and two physicians (see Acknowledgements). The heart and soul of our team is vested in the support we receive from an on-going, crop of JHU engineering student Research Assistants (RAs).





**Figure 2. Passive Mockup, Side View w/Zipper**

### **2.3 Condensed Course Syllabus [includes course structure] (By Edward Land)**

Semester Requirements for all candidates [Classes run Tuesday evenings 6 to 8 PM]:

1. Prepare sketches and 3-D renderings of assemblies and sub-assemblies and save to Dropbox site.
2. Draft preliminary assembly instructions and conduct peer-review with assigned team members.
3. Establish and maintain working relationships with OEMs, suppliers and other Johns Hopkins University personnel.
4. Develop comprehensive understanding of: Rapid Prototype processes, memory metals, Peltier devices (TEC/TED), bi-metallics, EMG and temperature sensors, IMES type neural implants and wireless micro-controller communication devices.
5. Be willing and able to sew fabrics, assemble (or assist in the assembly of) references, summaries, findings, citations, presentations, grant applications, newsletters and press-releases; review same with instructor.

Internship(s): Prospective BME, ME, EE & 1<sup>st</sup> and 2<sup>nd</sup> yr Medical Student Research Assistants. Work assignments- Your team will develop a strategy, adopt a design, compare and contrast workable ideas through synergistic team collaborations working with 2-3 RAs (max). Your group shall include observations and findings, through the elimination of less robust designs in favor of simpler, more aggressive, and better suited ones. Selected students/RAs will be assigned to continuously review the on-going progress of competitive device designs and report their weekly progress/status to other classmates.

Graduate students or special students such as those receiving grants or stipends may also qualify as credit seeking. A 4-page, pre-approved\*, research paper is required for all undergraduates (N/A for those seeking 1 credit hour). Graduate (first and second year) medical students who have pre-registered for multiple-semester assignments: a 15-20 page 'Journal Ready' primary research paper is required.

Research papers must focus and report on each, individually approved subject by providing a summary with a conclusion and most importantly, a recommended 'path-forward' (and reasons why). Sample research formats are available for review in our HOAD "Dropbox" for undergraduates. Graduate students are to follow any recognized 'physical science' journal such as Medical Device and Diagnostic Industry.

All RAs will need to plan for (and demonstrate) at least 40 total hours of dedicated work per semester to achieve consideration for each credit hour attempted.

Your performance will be evaluated on:

Computer Aided Design (CAD) renderings (requires peer review)	@15 – 20%
Class participation and relevancy	@15 – 20%
One general subject quiz [for new RAs only] (pre-announced)	@05 – 15%
Lab participation and project leadership/ project volunteerism	@15 – 25%
Research paper on a pre-approved topic* (related to our enterprise)	@25 – 30%
Weekly WEB informal research assignments (w/in-class presentations)	@10 – 20%
1 – 2 presentations per person, per semester to include:	
Grant submissions, HOAD planning, forecasting, updating;	
Managing activities; News releases/updates @ one per semester;	
Product, component, process & /or material assessments ~ two per wk.	

Basic and Applied Research can be a lot of fun but your grade will cost you some time and dedication. Should you accept this challenge, please schedule your time accordingly. Our lab is open from 7 am until 5:30 on Tuesdays and on Thursdays from 7 am – 7 pm.

## **2.4 Student Participation** (By Edward Land)

The students and faculty were given an interest inventory chart to complete shortly after formal class registration, in which they rank their level of interest and competence for various activities that will be needed by the project over the semester. They indicated the following on the chart: Their Proficiency, Interest, Willingness to learn, Willingness to teach, and if they were already working on it. At the conclusion, they assigned weighted values for each category listed. (See Table #1)

		Edward Land	Michael Marcus	Jon Hunt (V)	Noah Greenbaum	Rohit Dayal	Sally Hong (V)	Aaron Abugaber (V)
Clean up:	HOAD	I,T (1)		I3	I2	IP	I2	I
	Lab	P,T (1)			I3	IP	I2	I
Project Management:	Develop Milestone Event Schedule	IP,T (1)		I2,L		I2		
	Develop Parts Tree	I,T (1)						
	Implement Naming Convention	I,T (1)					I1	
	Procedure Development	IP,T (1)		I1				
Technical Skills:	CAD	I, L		I1,P2/3	P2	I1, L	I2, L	I1, P2
	3D Animation	I, L			P2	I1, L	L	
	Programming	I		I1,P1	P2			
	Photoshop	I				I1, L		
	Rapid Prototyping (Training Required)	I,L			P2, T		L	I1
Tech Research	Basic	IP,L (1)				IP		
	Applied	IP,L (1)		I2				
	Prior Art/Predicate Products	IP,L (1)				I2		
	Competitive Products	IP,T (1)	I2	I2		I2		
Materials	Research	IP,T (1)					P2	
	Selection	IP,T (1)						
	Testing	I,T		I1			I2	
Next Gen Tech	Electroactive Polymers	I,L						
	TED/Peltier Devices	I,L	I2		I2, P2			
	Piezoelectric Devices	I,L		I2,L				
	Micro Linear Actuators	I,L	I2,P2	I2				
Passive Device		I,T						
Active Device	Bushing	I,T (1)						I1
	Heating Elements	I,L	I2					
	Housing Manifold	I,T (1)						I2
	Electrical Components	I,L	I1,P2,T2					
	Microprocessor	I,L	I1,P2,T2	I1,P1				
	Wireless Communication				I1, P2			
	Sensors and Controls	I,L	I1,P2,T2	I1				
	Battery Selection and Charging	I,L	I2					I2, P2
Prototypes	Finish Mock-up	IP,T (1)				I3		
	Develop Passive Device Prototype	IP,T						
Lab Testing Development	Finger Force Data Collection (Labview)	I,L	I1,P2,T2	I1,L			I2	
	Strain Gauge Force Mechanism	I,L	I2	I1,L			I2	
Establish Collaborations		IP,T (1)						
Patient Recruitment		I,L						
Presentations		IP,L (1)	I1					
Grant Work	Solicit funding	IP,T	I2			I2,L	I2,	
	Write up applications	IP,L (1)	I2			I2,L	I2,P3	
	File applications	IP,L (1)					I2	
Patent	Research	IP,T (1)					I1	
	Filing	IP,T (1)					I1	
FDA Protocol Testing		I,T	I1,P2,T2			I2,IP		
Multilingual	[Fill in Languages]							
	Spanish					P3	P3	
	German							
	Chinese							
	Korean						P1	
Legend:	Hindi					P1		
Proficient	P							
Interested	I							
Willing to Learn	L							
Willing to Teach	T							
In Process (Already Working on it)	IP							
Level	1 [High], 2 [Medium], 3 [Low]							

**Table 1. Faculty and Student Interest Inventory Sheet**

### 3. Work performed by HOAD student Research Assistants

#### 3.1 Description of the two hand-assistive devices (By Noah Greenbaum)

The Hand-Opening Assistive Device from HOAD Research is a glove that contains special (purpose-built) hardware to allow a patient with compromised hand functionality to open that hand. There are two versions in development; an unpowered (“passive”), “spring assisted” version, and a powered (“active”), “computer controlled” version. While both passive and active devices are related in form and function, they serve two distinct purposes. The passive device has a lower overall cost and complexity (Fig . 2) . It may be adapted for a majority of stroke, accident and injury cases. It is best suited for most applications involving neurological trauma to

the head, neck, elbow, arm and hand resulting in a dysfunctional hand. The highly customized, active device, however, has much tighter specifications, allowing for volitional control of individual fingers of the hand and discrete feedback to the computer (Fig. 3). Note: Active Nitinol (NiTi) driven-hand HOAD orthotics must be operated in a controlled (enclosed) environment such as the home or office. These devices are typically custom programmed to operate optimally, indoors unless otherwise specified.

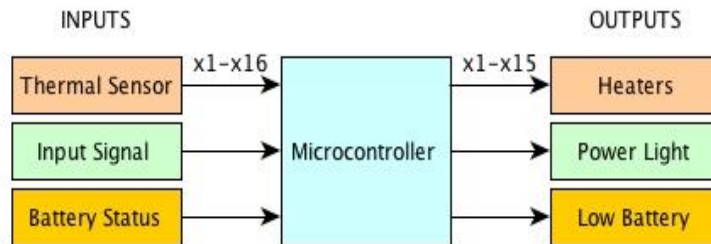
The passive device is entirely mechanical. Straight strips of a super-elastic NiTi material are elevated just above the fingers, and the force generated by each strip is sufficient to overcome the patient's deficit. The patient is able to override the material by applying a controlled counterforce, permitting the patient to modulate their hand function with their own grip control. The lifting actuator strips are integrated into channels in the glove to prevent lateral slippage and minimize the (low profile) height of the device to about one-half inch. The blades are anchored just above the finger tips and travel above the knuckles, terminating above the hand, where a stack of PTFE-coated fiberglass blades constrain their vertical movement and allow for finger splay without blade clash. Easy access to the blades and the stack is provided via a zipper that is later "stop-stitch" sewn to prevent unintended access. The wrist is mobilized in a similar manner as the fingers, but the blades enter the stack from the reverse side. For the thumb, cylindrical rods of the same super-elastic NiTi are constrained in nylon channels, which provide the same restorative force without overly restricting the natural range of motion of the thumb.

The active device allows for fine control of the compensation for the patient's deficit, as well as being an "on-demand" device rather than applying constant force. This on-demand force is exerted on each finger individually by a NiTi strip that has been shape set "annealed" in a flattened form, mimicking a finger's full extension. The patient has the ability to close their hand as normal, as the NiTi is malleable below transition temperatures. When the NiTi is heated, it returns to its shape-set annealed form. This provides an even and powerful force across the entire finger, and in concert with the other fingers, opens the hand.

In a clinical setting, the passive and active devices overlap in function and potential application. The passive device requires lower labor and cost to produce, assemble, and maintain, as the materials are chosen for strength and durability characteristics and require no batteries to operate. It can be used in a controlled setting for rehabilitation therapy, or for extended use in an outpatient setting. The active device is more expensive, but offers increased control, creating a more versatile device. In addition to inpatient and outpatient therapy, the device would be appropriate for patients with permanent deficits, restoring function to an otherwise minimally useful hand. In addition, the granular control can restore function to single fingers or joints, correcting a wider range of deficits than the passive device.



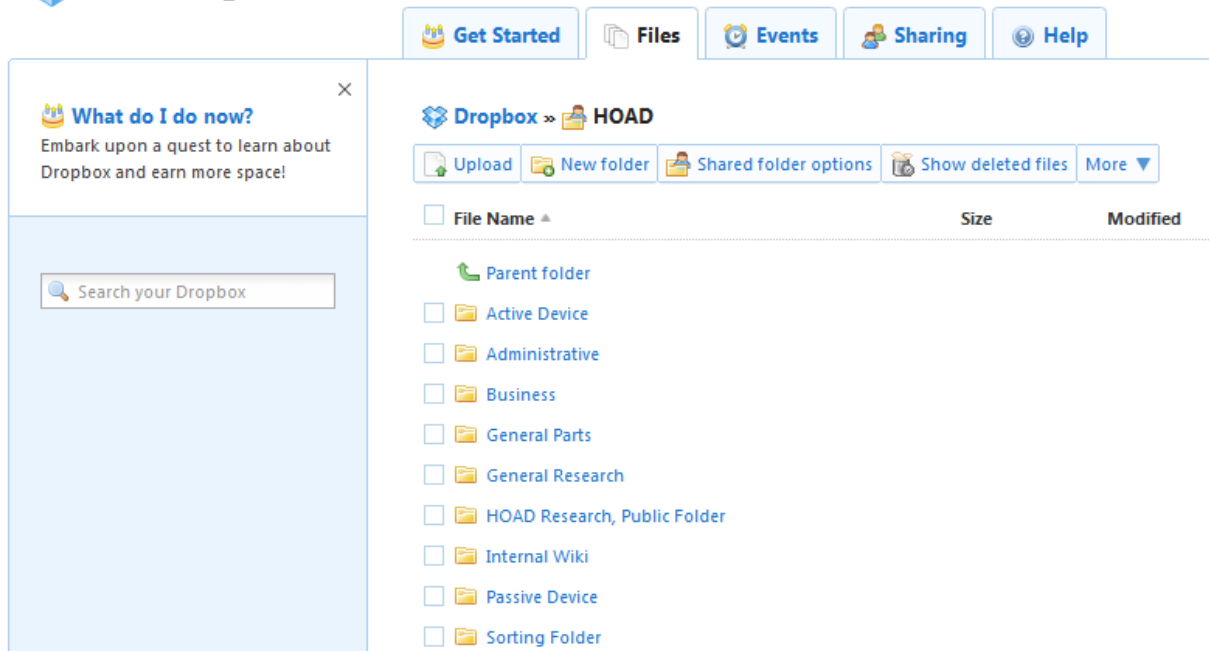
**Figure 3. Passive Mockup, Top, Interior View**



**Figure 4. Block Diagram of Active Device showing Control Circuitry**

### 3.2 How Documented (By Joseph Saltzman)

Every element of each student’s contribution to research is maintained interactively such that member students or faculty are able to review the latest version and with permission, are allowed to peer review/edit any file of interest. In this manner, anything stored in HOAD Research Group “Dropbox” is the latest rendition. Users may also elect to restore earlier versions should that become necessary. Below is a sample of this format:



**Figure 5. Generic “Dropbox” Web Site Offering**

### **3.3 Force Testing and Measurements (By Noah Greenbaum)**

As a prerequisite for customizing a HOAD glove-like device for a client, a doctor or clinician must measure the severity of the client's hand-opening or closing deficit for each affected finger or other medical trauma that may qualify them as a suitable candidate to use either of the HOAD hand orthotic devices. Patient dysfunction and severity measurements must be collected in order to pre-qualify them and to determine the counter-force actuator blade(s) best suited for that particular patient. HOAD Research Group is developing a method to measure the finger strength deficit for each individual finger. The client would utilize an electronic force measurement instrument and apply his or her maximum finger extension force against the instrument, producing a measurable voltage within the force measurement device, and would repeat the process for each finger of the affected hand. This force measuring instrument would be connected to an input channel of National Instrument's data acquisition hardware, allowing the data to be transferred to a connected computer running LabVIEW, a GUI-based programming environment. Using a coding structure our research assistants are developing, the LabVIEW program which will collect the force voltage data of each finger, calculate the force associated with the voltage data, and output a data table conveying the client's extension force for each individual trial and the deviation of the client's extension force from the norm. Obtaining this data, the doctor or clinician may determine the type and number of NiTi blades that should be installed into each specific actuator blade channel of the HOAD glove to match the client's individual needs, thereby optimizing the HOAD glove's effectiveness for each individual patient.

### **3.4 Searching for competitive devices (By Sally Hong)**

On-going searches for competitive devices are performed. The table below is an “Excel” extract.

Company	MSRP [\$ USD]	Active/ Passive	Commercial or R&D	Use	Ease of dress (don/doff)	Light weight	Low profile	Range of Motion	Wrist position	Comfortable	Weather Resistant
#1	7908	A	C	Full	Y	Y	Y	Y	None	Yes	N/A
#2	38	P	C	Full	N	Y	Y	None	Fixed	Yes	Yes
#3	305 (base)	P	C	Full	Y	Y	Y	N/A	None	Yes	Yes
#4	240	P	C	Supervised	Y	Y	Y	Partial	None	Yes	Yes
#5	1000	A	R&D	Supervised	N	N	N	Partial	Fixed	N/A	N/A
#6	1000	P	C	Supervised	Y	Y	Y	N/A	N/A	Yes	N/A
#7	1690	P	C	Supervised	N	N	N	N	Fixed	No	Yes
#8	119	P	C	Full	Y	Y	Y	None	None	Yes	Yes
#9	N/A	A	R&D	Supervised	Y	Y	Y	Full	None	Yes	No
#10	40	P	C								
#11	N/A	A	R&D	Supervised	N/A	N/A	Y	Partial	None	N/A	No
#12	not on market	A	R&D	Supervised	N/A	N	Y	Partial	None	Yes	No
#13	117	A	R&D	Supervised	N/A	Y	Y	Partial	Fixed	Yes	No
↓					↓						↓
#23	not on market	No	R&D	Full	Y	Y	Y	Partial	None	No	Yes
JHU HOAD	Competitive	A,P	R&D	Full	Y	Y	Y	Full	Full	Yes	Yes

**Table 2. Competitive/ Predicate Devices [sample extract]**

### 3.5 Meeting FDA regulatory requirements (By Rohit Dayal)

#### **FDA Medical Device Approval Process for HOAD Research Unpowered and Powered Glove-like Devices (an overview)**

Navigating the FDA process for a medical device is difficult, no matter the kind of device. Depending on the complexity and safety issues of the device, the approvals process can stall, move through several convoluted steps, and possibly even revert to previous steps. Fortunately, there are classes and lecture series dedicated to explaining these intricate steps to developers. The HOAD Research team broadened their knowledge base on the FDA process at a (XXX) FDA lecture series taught by visiting professors who currently work at the FDA.

The “take-aways” from the class, talks with FDA officials, and other medical device companies for the HOAD Research team enables us to navigate the process effectively and determine that both devices can reference predicate devices currently on the market to establish them both as Class I devices. One can find predicate devices on the FDA website and is an immensely useful resource for any device developer - no matter how big or small. The site is as follow:  
<http://www.accessdata.fda.gov/scripts/cdrh/cfdocs/cfPMN/pmn.cfm>

The following are steps of the FDA process: (1) Investigational Device Exemption for preclinical trials, (2) Premarket Program Submission to determine its risk classification, (3) Design Controls to ensure device design conforms to end-user specifications, and (4) Post-market Surveillance Program to check device safety after FDA approval.

HOAD Research will have to devise a clinical testing program for its two devices to show them as substantially equivalent to predicate devices currently on the market. After this is established, the HOAD devices can clear a 510(k) premarket notification since it is substantially equivalent to a predicate device and avoids significant costs and time to process since a similar device has already been approved. The HOAD devices will likely spend less than the average amount of time in the FDA device process because it has evidence of being “substantially equivalent”. This could not have been done without significant research on the FDA website and the informative FDA lecture series hosted by Johns Hopkins - both extremely valuable teaching tools.

### **3.6 Other Regulatory Agencies (By Michael Marcus)**

During my industry tenure, I submitted Hematology Analysis Equipment to various regulatory agencies. The FDA Class of equipment was clearly defined and the path to take with the FDA was already established with other similar (predicate) devices within the company. However, the path to take with the FDA for these Hand-Opening Assistive Devices was a unique challenge. After attending the FDA in-house, lecture series at Johns Hopkins, School of Medicine, and a workshop from Medical Design and Manufacturing (MD&M), I gained more knowledge of the requirements for these devices and how to receive up-to-date, FDA information related to medical devices.

Since the Active HOAD appliance includes electronic circuitry, one other area that we will look into is to apply for the equivalent of an Underwriters Laboratory (UL) listing, but use a harmonized standard IEC 60601-1, which also covers other countries. Additionally, we may seek a specialized marking for Medical Equipment for the European Union (CE Marking) when the devices are to be sold through licensees in Europe.<sup>3</sup>

### **3.7 HOAD Student Self-Evaluation (By Edward Land)**

Student: \_\_\_\_\_ Advisor: \_\_\_\_\_ BME, MechE, or EE: \_\_\_\_\_  
Evaluation date: \_\_\_\_\_ Your email: \_\_\_\_\_ Other participating team members: \_\_\_\_\_

Instructions: The following self-assessment is to be completed via email; you have seven days. Identify all response entries by the item number shown below.

Notes: A. Grade yourself using 1 as “BEST performance”, on a five scale.

B. Ensure that you include this page with your email response.

Basic precepts: Participating RA students are graded on their...

1. Active lab/ class-room participation [You must attend regularly.] —
2. Team leadership [planning, peer review teams, needs assessment & futures forecasting] —
3. Demonstrated technical competence and growth—
4. Quality of completed assignments —
5. Volunteerism [weekly assignments, parts lists, product research, news letter updates]—
6. Weekly time-tracking [a bona fide requirement, in-lab @ 6 – 9 hours/wk] —
7. Comprehensiveness of work—
8. Depth of knowledge and understanding of particular subject matter [including quiz results] —
9. Relevant use and application of technical terms in the area of:
  - Your term paper—
  - Biomechanics—



- MS suite of products [and computers in general] —
- CAD renderings [quality & completeness] —
- Material & component assessments—
- Process improvement & lessons learned—
- Mechanics, manufacturing, assembly, physics—

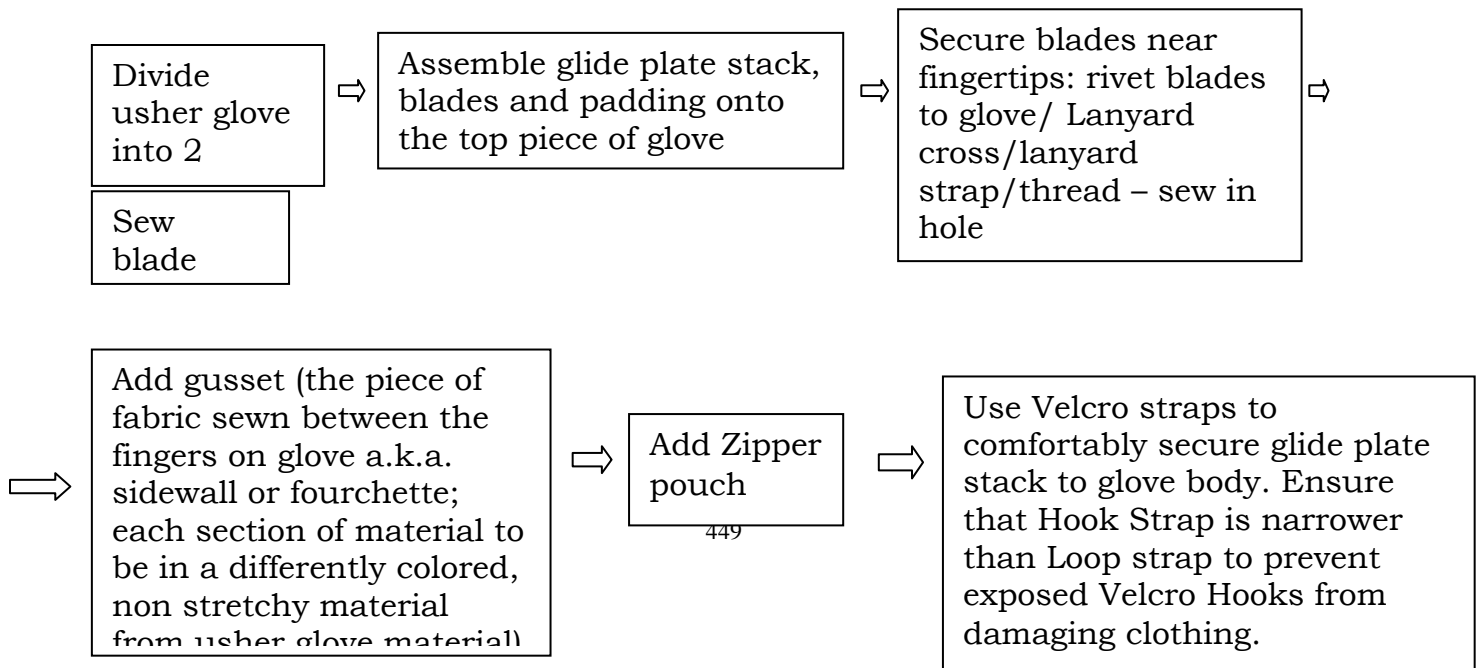
Footnote: “Students must provide examples for each response offered (See above 1 - 9).”

#### 4.0 The Project Development Research Process (By Edward Land)

##### 4.1 Steps in Project Development, [Process Flow Chart]

Define the problem> map out viable solutions> survey materials & methods> determine affordable option (time, materials, facilities & technologies)> develop preliminary sketches> review competitive devices (regularly)> assemble detailed sketches & CAD renderings> conduct internal peer review> review plan for soundness> conduct extensive “what if” evaluations> develop proof-of-concept> sell idea to management> acquire access to labor, facilities & test equipment> focus efforts to build collaborative team> recruit support network> recruit/maintain research assistants> draft provisional patent<sup>6,7</sup> application> request material donations for testing> develop mockup device> evaluate student performance> assign grades> establish collaborative relationships with internal technology transfer department> file patent application(s)> roll lessons learned into mockup> construct 1<sup>st</sup> generation prototype> invite OEMs & Financial Angles to review progress> establish collaborative relationship with Veterans Administration, local businesses and other educational institutions> evaluate “doable” internal & external grant applications> develop one-year realistic grant opportunities> review opportunities with collaborators> develop internal & external Milestone Event Schedules> assemble MES timeline with team of assigned student RAs> identify all required cost elements> compose a budget w/justifications> file targeted grant applications (do not overreach)> locate suitable venues to publish research efforts> select only one publisher for each writing effort> develop documentation suitable for publishing> concurrently meet all monthly grant expectations> apply for follow-on grant monies> down select manufacturing facilities> license technologies and IP for university> OEMs must have access to supply chain/distribution system> transition licensed technology to full service OEMs.

##### 4.2 Value Stream Map



### **4.3 RA Rules to Live By [Issued to all students]**

- Your class attendance is mandatory.
- You must be willing and able to perform lab duties and record your time.
- Volunteers are not required to submit a 4 page (min) research term paper but your submission is encouraged (its good exercise).
- You must be passionate about learning and contributing.
- You must demonstrate ability to improve Mechanical & CAD rendering skill sets.
- First timers are required to take and pass a twenty-question, pre-announced quiz.
- You must be willing and able to synergistically work on 2 or 3 person teams and make yourself available to do so.
- You must be willing and able to timely conduct assigned research activities and communicate your findings to your instructor.
- You must respond to your instructor's inquires (its mandatory).
- You must deliver the goods on time every time; your commitment is your bond.

### **4.4 Benefiting from the University Library System (By Edward Land)**

NOTE: When conducting your research from any university library system, substitute your particular engineering discipline for the term "medical".

- Use "Google Scholar" when searching for either very detailed information or broad, multidisciplinary info. Scholar gives mostly journal article citations. Use Google as a last resort and with phrases in quotation marks to narrow your search as much as possible.
- From a research perspective, we are concerned with 'granularity'; the process of reducing our search down to the level of detail where most of the answers we seek may be found.
- Useful "medical" data bases and web sites to examine: CDC; Pub Med; Institutes; Fast Stats: National Center for Health Statistics; market.research.com/academic; RefUSA; Medical Device Register; Space Modern- BME Devices; Community of Science; Chronicles of Higher Education and the Hanger Orthopedic Group.
- When looking for patient reimbursements to offset the cost of purchasing our device(s) examine applicable Center for Disease Control and Prevention (CDC) codes, collaborate with the Veterans Association to recruit their patients and establish a medical necessity on their letterhead.
- Under Pub Med, carefully examine the 'first paragraph' and not the abstract to see if the information you seek is available in the document.

- Under Institutes, look for ‘neuro’ and stroke to locate related organizations.
- Cross referencing tools: Review engineering- BME- FDA- regulations- CFR- CDC- Traumatic Brain Injury (TBI) topics.
- RefUSA has dollar amounts listed by product.
- Medical Device Register is a ‘print-only’ publication that is available in two volumes. One volume, lists manufacturers while the other is sorted by key words. These may not be checked out of the library!
- [www.oandp.com/articles/news\\_2007-09-28\\_01.asp](http://www.oandp.com/articles/news_2007-09-28_01.asp) Prosthetics Market Growing
- [www.aopanet.org](http://www.aopanet.org) American Orthotic & Prosthetic Association
- [www.hanger.com](http://www.hanger.com) Hanger Orthopedic Group – Prosthetics, Orthotics, Artificial Limbs, ...
- When using the JHU Sheridan Libraries as a research tool it is important that you start with their ‘Advanced Level’ search function and drill down from there.
- Examine GRAY SHEET and click on the heading ‘more options,’ and then check the boxes for GRAY SHEET and the one right underneath, “Health News Daily,” because those are the only ones that we own.
- In PubMed, (1) always go through the library web site to PubMed, and DON’T use “pubmed.gov.” The reason is that we have our full text linked to PubMed but you won’t get it if you use the generic URL. (2) In PubMed, Look at the bottom under MeSH (Medical Subject Heading). This is the world’s best thesaurus and will be great at helping you narrow down what you’re hunting for.
- Other library reference materials are also available in the lab for your review. We have hand-outs on the following subjects: National Institute of Neurological Disorders and Stroke (sub categories include definitions, treatment, prognosis, current research and patient recruitment for clinical trials); Traumatic Brain Injury (sub-categories include distribution by age, State, cost, outcomes, gender, population, risk, prevention and treatment.
- Collexis is a Hopkins internal database document that contains published works of BME experts, taken only from PubMed. If however, other scientists and researchers have not yet published; their efforts and contributions will remain unknown to the outside world. This no doubt, also applies to all institutes of higher learning. The message to take home is that you will never know for sure what competitive research is underway unless you physically pick up the phone and ask.

## **5. HOAD Devices**

### **5.1 Intended use (By Edward Land)**

Over a million stroke victims in the US alone (1) are unable to open their affected hand. Yet, a portion of these individuals, estimated to be 220,000, retain their ability to volitionally control their arm and their hand grip strength. Our charter is to develop comfortable, low profile and robust hand-assistive glove-like devices which enable the wearer to reopen their affected hand.

The successful completion of each of these devices has strong national and global implications to the patient and to the marketplace.



**Figure 6. Passive Mockup Device, with Zipper Access, Side View**

A total of four (4) US and foreign patents are pending (July 7<sup>th</sup> 2011) for two passive (spring assisted) and three active (computer controlled) hand-orthotic devices. For individuals who have retained their grip and their ability to direct their arm movements, but not the ability to open their hand, each customizable device will offer the stroke, traumatic brain injury (TBI) or ulna nerve patient a counterforce sufficient to extend the user's hand by overcoming grip strength and improper wrist positioning.

#### **6. Collaboration with Business and Industry (By Edward Land)**

Extensive collaborative relationships have developed over the past five years in support of our assistive device charter. Under a joint venture agreement among JHMI School of Medicine, PM&R Department the BME, MechE and Electrical Engineering Departments at JHU Homewood campus our team is fortified each semester, with undergraduate and graduate research assistants.

We already have in place, a letter of understanding that 1<sup>st</sup> and 2<sup>nd</sup> year medical students are invited to participate in a pilot study or clinical trials as our research matures and the need arises for clinical trials. Over this same period, we have had access to the use of rapid prototyping machines being offered by a local, Baltimore firm, PCS; material donations from: BSST include a working Peltier (thermoelectric device); Northrop Grumman Corporation include a \$2200 KEPCO power supply; Signode Corporation including a plant tour, banding straps, tools, clamps; Johnson Matthey and Fort Wayne Metals Corporations including expensive NITINOL material samples; Ansell Health Care Products, located in SC (military glove division), have provided about thirty (30) pairs of sample gloves provided to HOAD Research Group. Additionally, we have located a glove designer source at Clemson University (Clemson Apparel

Research) a strong glove design subcontractor. Alternatively, we have located as a back-up plan, Carolina Glove and Safety Company located in Conover, NC.

### **7. Future Direction** (By Edward Land)

At this time we are in the process of updating a third generation, passive, spring loaded, glove-like, assistive device prototype test fixture. Our first three mock-ups did not contain provisions for an articulating thumb, nor physical Nitinol (NiTi) actuator lifting elements while the fourth version will be designed to include these capabilities. These super-elastic (Ni Ti), stainless steel or fiber impregnated counterforce actuator elements are designed to permit a patient's full hand to open easily, (assuming that the patient already possesses the ability to extend and splay their fingers). We are constantly on the lookout for qualifying grant opportunities. Soon, we will be developing two grant proposals; one is internal JHU ATIP, the other is for the State of MD through TEDCO. FYI, Our internal Hopkins ATIP grant proposal opportunity occurs every six (6) months.

### **8. Next generation development** (By Edward Land)

It is important to note that over the past five (5) years, this enterprise, save for corporate contributions previously mentioned, was developed exclusively by volunteers. Credit seeking and volunteer students have basically paid the university to participate in our program and their contributions have been noteworthy in that they, as research assistants, are required to produce term papers that after faculty edits are worthy of study by other students who also support this program as new volunteer researchers.

As hardware designs have matured, internal entities such as JHU Technology Transfer and outside organizations like Clemson University and MYOMO are beginning to take note. As mentioned earlier, we have successfully filed patent applications which provide us with a better understanding of the implications and technologies that will be needed to refine our device ideas. A better understanding will also enable us to affordably offer these refined devices to those in need and perhaps offer them a better quality of life in the process.

We also realize that, we must now infuse real monies from grant capable sources to continue to drive this to fruition. Grant monies will permit us to complete our efforts to have working devices suitable for testing and evaluation, case studies, pilot program development and clinical trials. Additionally, it has become increasingly clear that our active (computer controlled) hand-orthosis models, may have other useful implications in the development of assistive devices for other body parts or as a scale-to-need, light weight, alternative to heavy motor driven robotic tools.

### **9. Conclusion** (Visiting Michael Marcus and Edward Land)

As a result of my joining the HOAD Research project team, I now have a road map of how a major collaborative Research Project functions involving Faculty, Undergraduate, Graduate Students, and how to gain support within the University and from industry. I learned how to structure a course to interest undergraduate and graduate students who take the course for credit, and as volunteers. Students learn individual elements and all phases of research and product development, which make them more knowledgeable as Researchers and Engineers and therefore more attractive to academia or industry upon graduation. I was encouraged to see how students eagerly participated in brain storming sessions, led by the Edward Land the Director of the Hand Opening Assistive Device Project. Ed taught and mentored participants to work synergistically and drive HOAD Research to fruition by establishing a plan-forward, and never without a Plan-B as an alternate solution. From an interactive Milestone Event Schedule, students were encouraged to select an area of interest that best suited them. In this way students

are able to accept leadership roles or work with their instructors and other students who were willing to learn as the group conducting research or worked on CAD renderings etc. Students who had previously expressed an interest in a particular subject were asked to make direct contributions in those areas; some of their work is also included in this paper. As these two hand rehabilitative devices progress, it is our intention that these devices advance in sophistication permitting them to achieve their intended goal of enabling people with hand disabilities improve their quality of life.

## **References**

1. Marcus, M.L.; Team Problem Solving Strategies Used by Industry and Implemented by Students of Engineering Technology. Tech Directions, pp. 23-25, February 2003.
2. Marcus, M.L.; Winters, Dixie; Team Problem Solving Strategies with a Survey of These Methods Used by faculty Members in Engineering Technology. The Journal of STEM (Science, Technology, Mathematics, and Engineering) Education: Innovations and Research, pp. 24 – 29, January – June 2004.
3. Marcus, M.L.; Biersach, B. R. (Underwriters Laboratories); Regulatory Requirements for Medical Equipment. Institute of Electrical and Electronic Engineers Instrumentation & Measurement Magazine, vol. 6, No.4, pp. 23-29, December 2003.
4. Heller, RS; Beil, C; Dam, K; Haerum, B. Student and Faculty Perceptions of Engagement in Engineering. JOURNAL OF ENGINEERING EDUCATION, ISSN 1069-4730, 07/2010, Volume 99, Issue 3, pp. 253 – 261.
5. Tennenhouse, D (08/31/2004). "INTEL'S OPEN COLLABORATIVE MODEL OF INDUSTRY-UNIVERSITY RESEARCH". *Research technology management(0895-6308)*, 47(4), p.19.
6. International Patent Application, No. 13/178,083, Filed July 7<sup>th</sup> 2011. Low Profile Hand-extension/Flexion Device (JHU Ref. Nos. C10943); International Application No. TCT/US11/43179 and US Provisional Patent Application No. 61/382,627, Filed September 14, 2010.
7. International Patent Application, No. 13/177,844, Filed July 7<sup>th</sup> 2011. Active Hand-Extension/Flexion Device; US Application No. P11548-02

## **Acknowledgements, Faculty and Other Collaborators:**

Gad Alon, Ph D, University of Maryland, Baltimore County Campus  
John Staehlin, Retired Westinghouse and Northrop Grumman, Consulting Mechanical Engineer  
Ken Silver, Physician, Johns Hopkins University, School of Medicine, PM&R  
Lee Mantelmacher, CEO Maryland Prosthetics and Orthotics Corporation  
Marlis Gonzalez-Fernandez, Physician, Ph D, Johns Hopkins University, School of Medicine, PM&R  
Rebecca German, Ph D, Johns Hopkins University, School of Medicine, PM&R  
Wayne E. Moore, Ph D, Johns Hopkins University, School of Medicine

## **Contributing Volunteer and Credit Seeking Student Research Assistants:**

Alex Artaki, Matti Makela, Tabor Barranti, Emilie Yeh, Seong-Tin Seonwoo (Nate), Aaron Abugaber, Yufeng Guo, Taig Rajpal, Joey Saltzman, Tony Ye, Lorre Atlan, Shijit Dasgupta, Danielle Dorfman, Noel Sanjuan, Noah Greenbaum, Minyoung Jeon, Jonathan Hunt, Rohit Dayal, Justin Lee, Sally Hong, Yuan Feng, Akash Ray, Fawaz Ahmed, William Rothkopf and Krzysztof Sitko.

## **Testing Jigsaw Learning Against a Traditional Lecture**

Orla Smyth LoPiccolo, Architect  
Assistant Professor & Secretary and Treasurer, ASEE Mid-Atlantic Section,  
Farmingdale State College, State University of New York  
Department of Architecture and Construction Management  
2350 Broadhollow Road, Farmingdale, NY 11735  
ph: 631.794.6123 fax: 631.420.2590 orla.lopiccolo@Farmingdale.edu

## Testing Jigsaw Learning Against a Traditional Lecture

Orla LoPiccolo, M Arch, RA, Assistant Professor  
Department of Architecture and Construction Management  
State University of New York - Farmingdale State College

### Abstract:

Oppenheimer said “The best way to learn is to teach.”<sup>1</sup> Mazur found that “Nothing clarifies ideas better than explaining them to others.”<sup>2</sup> Using this philosophy, Jigsaw Learning,<sup>3</sup> is a peer-to-peer teaching method developed by Elliot Aronson in which every student teaches something that they have learned from one study group to another group of students. During class, the faculty breaks a course topic into different assignments and the class into the same number of study groups. The study groups each contain an equal number of students. Each group is given an assignment to read, discuss and finally decide how they will serve as instructors on their topic. The faculty visits each group to discuss the topic and answer questions. After this study period, new jigsaw learning groups are formed that contain a representative from each of the original study groups, thereby bringing all of the course topics together in one group. Each representative is asked to instruct their group on what they have learned. The groups are then disbanded and the class is reunited for review and to answer remaining questions in order to guarantee correct understanding.

The goal of this paper is to test Jigsaw Learning against a traditional lecture as a teaching technique on the same topic for freshmen Architecture and Construction Management students who have been benchmarked using a prior test. The test group is given the Jigsaw Learning method, while the control group is given a lecture on the same topic. The timeframe for the exercise is the same for both groups – i.e. one hour of a class that is nearly 3 hours in duration – and immediately following, both groups were given the same test on the topic. The results of this study will provide faculty with an understanding of the relative benefit of the initial implementation of Jigsaw Learning into their courses.

### Introduction:

The goal of this paper is to quantitatively and qualitatively test the traditional lecture against an active learning, peer-to-peer teaching method called Jigsaw Learning that the author implemented for the first time early in the fall semester of 2011, in a freshman Materials and Methods of Building Construction I class.

In 1987, Thielens stated that 89% of U.S. professors lecture as a mode of instruction.<sup>4</sup> The current number of professors who lecture as the only mode of instruction, those who supplement lectures with active learning or those who only use active learning is unknown. Research has shown that students must do more than just listen to truly learn.<sup>5</sup> Surveys of learning styles have shown that 65% of our student population are visual learners, 30% auditory learners and 5% kinesthetic learners.<sup>6</sup> This may be true but there is more to teaching than presenting visuals. One type of visual presentation commonly used is the PowerPoint lecture, incorporating slides. It has been found that when lectures are turned into PowerPoint presentations, students cannot keep up writing their notes and if copies of the PowerPoint slides are distributed, students have little incentive to go to the lecture.<sup>7</sup>

In a previous study the author tested the active learning task of student-sketches lecture diagrams against students who passively looked at the same diagram on a handout. The active group achieved on average a 20% higher score than students who passively looked at the same diagram



on a handout.<sup>8</sup> Active learning according to Felder and Brent is “anything course-related that all students in a class session are called upon to do other than simply watching, listening and taking notes.”

Cooperative Learning is a collaborative active learning technique where students are placed into interdependent teams of 3 to 5 members and assigned a structured task such as “multiple-step exercises, research projects, or presentations.”<sup>9</sup> Per Johnson et al there are 5 crucial components for cooperative learning groups:<sup>10</sup>

- a. positive interdependence between students (“all for one and one for all”)
- b. face to face interaction
- c. individual accountability
- d. emphasize interpersonal and small-group skills
- e. processes must be in place for group review to improve effectiveness

Ledlow adds that equal participation is also important: “the structure of the assignment should be such that all students have to participate, and that there are mechanisms to ensure that the participation is fairly equitable. You may try assigning roles, adding steps to the lesson that require input from all team members, or establishing turn-taking procedures.”<sup>11</sup>

Per Kohn, cooperative learning emphasizes that students can learn together instead of against each other and that it works with all grade levels, all student abilities and in subjects such as “math and science, language skills and social studies, fine arts and foreign languages.”<sup>12</sup>

Jigsaw Learning:

Jigsaw Learning is a cooperative learning technique invented by Elliot Aronson in 1971 in Austin, Texas, to help to diffuse tension in the city’s classrooms after desegregation. Aronson and a group of his graduate students observed destructive competitive behavior amongst the white, African-American, and Hispanic children who were being taught together for the first time in a fifth grade classroom. Aronson and his team implemented their “Jigsaw” strategy in a random number of classrooms, which used jigsaw learning for a small portion of class time for 8 weeks. They then tested the jigsaw classes against the traditional classes. The following are their general findings.

“Jigsaw students:

1. Expressed less prejudice and negative stereotyping
2. Were more self-confident
3. Reported liking school better than children in traditional classrooms.
4. Were absent less often than were other students
5. Showed greater academic improvement; poorer students in the jigsaw classroom scored significantly higher on objective exams than comparable students in traditional classes, while the good students continued to do as well as the good students in traditional classes.”<sup>13</sup>

Per Robert Half, “When one teaches, two learn.” With Jigsaw Learning, every student teaches something<sup>14</sup> (their assigned topic – a.k.a. their ‘jigsaw piece’) to their jigsaw team after they

have read, questioned and discussed their topic in an “expert group” of different classmates. The Jigsaw Learning procedure is explained in the Methodology section below.

Reasons for Choosing Jigsaw Learning for this Study:

The author is a recipient of a Title III Students First Grant for engaging pedagogy and first-year programs, and this is their first time using and testing the Jigsaw Learning technique. This learning technique was chosen for the following reasons:

1. To ascertain the relative benefit of using a peer-to-peer active learning technique with a first semester freshman class.
2. To encourage students to communicate, provide teamwork practice and encourage learning techniques for self-directed continuing professional development – all of which are criteria of the “Program Outcomes for Engineering Technology Programs” by the *Accreditation Board for Engineering and Technology (ABET)*<sup>15</sup> and part of the American Society of Engineering Education (ASEE) Green Report – “Engineering Education in a Changing World.”
3. To add variety to a nearly 3 hour lecture class that does not have a laboratory component beyond soil sieve testing, thus helping to maintain the student’s interest.
4. The author has successfully used other active learning methods such as student-built physical models, student-produced visual dictionaries, and service learning, and is interested in finding other teaching methods to enhance lectures. Per Michael Prince – “Nonstop lecturing produces very little learning.”<sup>16</sup>

Methodology:

“Per Dietrich: “A Jigsaw requires more preparation by instructor and student than an informal study problem. The instructor needs to design the cooperative learning task appropriately, and the students must prepare outside of the class. The in-class discussion puts the puzzle together.”<sup>17</sup>

Two sections of Material and Methods of Building Construction I freshmen Architecture and Construction Management students were given the same pre-test on introductory wood topics in the fall of 2011. The pre-test results showed that both groups had an equal lack of knowledge of this topic and provided a benchmark for the post-test. The author gave the control group (n=12) a one hour lecture on the properties of wood and lumber. The second section of this course (n=25) was given the same course material as a Jigsaw Learning exercise which was conducted as follows:

1. The faculty informed the class that they will be working in teams and each member is responsible for their own individual section and for their group’s success in presenting a topic.

2. The faculty divided each of the following into the same number of segments: the material to be learned, the class into groups and each group. The course topic an introduction to the construction material wood – was divided into 5 segments, and the class of 25 students was divided into 5 heterogeneous groups each containing 5 students. (It is more constructive for the faculty to select diverse teams with up to a maximum of 5 members rather than permitting the students to form their own teams.)
3. The faculty informs the class that there will be a test at the end of the jigsaw time period. This ensures that the students are more attentive and that they know that their work really counts.
4. Each group is assigned a different segment to read/problem solve from their textbook or literature provided by the faculty. They become “experts” in this topic through study, discussion and sharing ideas on how they can present their topic to others.
5. The faculty visited each group, answered and asked questions to ensure the students understood their topic segment and the exercise and the faculty made presentation suggestions.
6. Each “expert” group member was then assigned a number from 1-5 and the “expert” group is disbanded at the end of the set study/discussion time.
7. All students with the same assigned number formed a new group – the Jigsaw Group. Therefore all #1 students were together, all #2 students were together and so forth. There were now 5 new groups that each contained 1 “expert” in each of the 5 learning segments.
8. Each group member taught their learned topic to the other group members and they are in turn taught by their peers. Therefore, each group member shared their course topic segment of the ‘jigsaw puzzle’ and learned from their peers. This completed a coherent group ‘jigsaw’ of the course topic.
9. Faculty visits each group and encouraged team members to ask questions, write notes, draw diagrams and interact.
10. After each student had completed their teaching assignment and there had been enough time for discussion within the groups, the students returned to their individual seats and the test was given on the complete topic.

After both the test group (traditional lecture) and the test group (Jigsaw Learning) were given a post-test. The post-test had the same questions as the pre-test to ascertain what the students had learned during each section of class.

Quantitative Results:

<b>Traditional Lecture</b>		
Student No	Pre-test	Post Test
1	1	10
2	2	10
3	0	5
4	1	8
5	2	9
6	0	10
7	2	8
8	2	9
9	4	7
10	8	10
11	1	6
12	1	9
mean	2.000	8.417

<b>Level of Significance for a Directional Test</b>				
0.05	0.025	0.01	0.005	5E-04
Non-Directional Test				
--	0.05	0.02	0.01	0.001
Z <sub>critical</sub>				
1.645	1.960	2.326	2.576	3.291

<b>Jigsaw Learning</b>			
	Student No	Pre-test	Post-test
	1	0	6
	2	1	8
	3	2	3
	4	2	6
	5	2	3
	6	2	4
	7	2	9
	8	0	1
	9	3	5
	10	3	6
	11	2	7
	12	3	3
	13	0	4
	14	3	6
	15	3	5
	16	4	7
	17	4	6
	18	5	5
	19	3	5
	20	1	3
	21	3	8
	22	2	5
	23	2	5
	24	8	5
	25	2	7
	mean	2.480	5.280

Qualitative Results:

The following are the results from a short survey given to the Jigsaw Learning group:

Jigsaw Learning Survey Results								
	Strongly Disagree	Disagree	Neither Agree or Disagree	Agree	Strongly Agree	Total # of Responses	Average Result	Average Result
Question	1	2	3	4	5			
I learned more working in teams than in a traditional lecture	1	11	8	5		25	2.68	Neither
I enjoyed sharing what I learned with my team		1	12	12		25	3.44	Neither
I would like part of my class time to be team based		4	9	10	2	25	3.4	Neither
Working in teams allowed me time to get to know my classmates.		2	6	14	3	25	3.72	Agree

I learn more in a class that is mainly:	
Traditional lecture/note taking discussion	6
PowerPoint lecture/note taking/discussion	15
Studio problem solving w/short lecture/discussion	4
Other	0
Total # of responses	25

Discussion:

The results of the quantitative is test indicate that the magnitude of z scores is greater than z-critical for confidence levels through 0.001. The lower average score for jigsaw learning group is statistically significant. This finding is similar to that of Thompson et al in 1998 and Slavin<sup>xviii</sup> in 1995. The Thompson et al paper titled “Cooperative Learning Versus Traditional Lecture Format: A Preliminary Study” states: “The results failed to document any significant differences in the scores of students taught by the lecture method versus students taught by Jigsaw.”<sup>xix</sup> Slavin found that students have limited exposure to the topic material that their team members are responsible for, so “learning gains on their own topics may be offset by losses on their group mates’ topics.” A separate study by the Johnsons found that the reward of group grades (based on the average of all group member individual scores) increased the achievement

of Jigsaw Learning.<sup>xx</sup> In another study, teambuilding activities alone had no effect on the achievement outcomes of Jigsaw Learning.<sup>xxi</sup>

The results of the qualitative test show that students in this study did not report benefits from the Jigsaw Learning activity beyond getting to know their classmates, which may increase their sense of community. The students' belief that they had not learned as much in the Jigsaw classroom activity was made evident by the results of the post-test above. Their negative response to active interdependent group work is also reflected in their majority vote for PowerPoint lectures – a largely passive exercise unless the faculty incorporates active questioning and problem solving within their presentations.

#### Conclusion:

The Jigsaw Learning activity described in this paper was performed in the third week of a freshman class. While this activity appeared to succeed as an “ice breaker” for the students, it failed in student retention of subject matter. This outcome, as reflected in the quantitative results, is largely based on the fact that the Jigsaw groups did not function as efficiently as a faculty member in teaching the set topics. Further research on this topic with larger sample sizes, the implementation of group grades as an incentive, and using Jigsaw Learning as a review method instead of an introductory method for new material is suggested.

---

<sup>1</sup> Frank Oppenheimer

<sup>2</sup> Eric Mazur, Harvard University, <http://mazur.harvard.edu/>

<sup>3</sup> Elliot Aronson, University of Texas and University of California, <http://www.jigsaw.org/>

<sup>4</sup> Thielens, W., “The Disciplines and Undergraduate Lecturing,” paper presented at an annual meeting of the American Educational Research Association, April 1987, Washington, DC, ED 286 436, 57 pp, MF-01, PC-03.

<sup>5</sup> Chickering, A. and Z. Gammons, “Seven Principles for Good Practice,” *AAHE Bulletin*, 39: 3-7, March 1987, ED 282 491, p.6.

<sup>6</sup> Gangwer, Timothy, *Visual Impact, Visual Teaching: Using Images to Strengthen Learning*, Sage Pub, 2009

<sup>7</sup> Felder, R.M., and R. Brent, “Death by PowerPoint,” *Chem. Engr. Education*, **39**(1), 28 (2005)  
[www.ncsu.edu/felder-public/Columns/PowerPoint.pdf](http://www.ncsu.edu/felder-public/Columns/PowerPoint.pdf)

<sup>8</sup> LoPiccolo, Orla, “What I See I Remember, What I Do I Understand” American Society of engineering Education, Middle Atlantic Section Fall 2010 Conference, Villanova University, PA.

<sup>9</sup> Paulson, Donald and Faust, Jennifer, Active Learning for the College Classroom,  
<http://www.calstatela.edu/dept/chem/chem2/Active/main.htm>

<sup>10</sup> Johnson, D. W., R. T. Johnson, and K. Smith, Active Learning: Cooperation in the College Classroom, Interaction Book Company, Edina, MN, 1991

<sup>11</sup> Ledlow, Susan, “Cooperative Learning in Higher Education,” Center for learning and Teaching Excellence,  
<http://clte.asu.edu/active/clinhighed.pdf>

<sup>12</sup> Kohn, Alfie Kohn, “Punished by Rewards. The Trouble with Gold Stars, Incentive Plans, A's, Praise, and Other Bribes” (Boston: Houghton Mifflin, 1993 / 1999

<sup>13</sup> Aronson, Elliot, History of Jigsaw, Social Psychology Network, <http://www.jigsaw.org/history.htm>

<sup>14</sup> Mel Silberman, Active Learning to Teach Any Subject, P 111, Allyn and Bacon 1996

<sup>15</sup> Criteria for Evaluating Engineering Technology Programs, ABET, 2011-2012  
<http://www.abet.org/Linked%20Documents-UPDATE/Criteria%20and%20PP/T001%2010-11%20TAC%20Criteria%2011-3-09.pdf>

- <sup>16</sup> Prince, M., "Does Active Learning Work? A Review of the Research," *J. Engr. Education*, **93**(3), 223 (2004)  
[www.ncsu.edu/felder-public/Papers/Prince\\_AL.pdf](http://www.ncsu.edu/felder-public/Papers/Prince_AL.pdf)
- <sup>17</sup> Dietrich, Suzanne W, Getting Started with Cooperative Learning in the Engineering Classroom  
<http://clte.asu.edu/active/mainart.htm>
- <sup>18</sup> Slavin, R.E., "Cooperative learning: Theory, research, and practice" 1995, (2nd Ed.). Boston: Allyn & Bacon
- <sup>19</sup> Thompson, Marceline, and Pledger, Linda, "Cooperative Learning Versus traditional Lecture Format: A Preliminary Study", 1998, National Communications Association
- <sup>20</sup> Johnson, D.W., & Johnson, R.T. "Learning together and alone: Cooperative, competitive, and individualistic learning" (4th Ed.). 1994, Boston: Allyn & Bacon
- <sup>21</sup> Rich, Y., Amir, Y., & Slavin, R.E. "Instructional strategies for improving children's cross-ethnic relations" 1986  
Ramat Gan, Israel: Bar Ilan University, Institute for the Advancement of Social Integration in the Schools

**Expanding access to engineering, science, and  
technology with an online pre-matriculation program**

VALERIE LUNDY-WAGNER  
New York University

IRAJ KALKHORAN  
MELINDA PARHAM  
YONA JEAN-PIERRE  
HAANG FUNG  
LINDSEY VANWAGENEN  
Polytechnic Institute of New York University

VALERIE LUNDY-WAGNER

Dr. Valerie Lundy-Wagner is an Assistant Professor and Faculty Fellow in the Higher Education Program at New York University. Her research focuses on student- and institution-level factors contributing to degree completion with attention to the ethnicity/race, gender, and socioeconomic status for all students and those in STEM.

IRAJ KALKHORAN

Dr. Iraj Kalkhoran is the Associate Provost of Undergraduate Academics and Associate Professor of Aerospace Engineering at the Polytechnic Institute of New York University.

MELINDA PARHAM

Ms. Melinda Parham is the Director of Freshman Programs at the Polytechnic Institute of New York University.

YONA JEAN-PIERRE

Yona Jean-Pierre is the Director of Faculty Innovations in Teaching and Learning at the Polytechnic Institute of New York University.

HAANG FUNG

Ms. Haang Fung is the Associate Dean for Undergraduate Success at the Polytechnic Institute of New York University.

LINDSEY VANWAGENEN

Dr. Lindsey VanWagenen is a lecturer in the Mathematics Department at the Polytechnic Institute of New York University; she is also the Director of Pre-calculus.



## **Expanding access to engineering, science, and technology with an online pre-matriculation program**

### Abstract

There have been numerous calls to increase the number of students interested in, matriculating to, and graduating from science, technology, engineering, and mathematics (STEM) bachelor's degree programs. In terms of expanding access at the K-12 level, stakeholders focus largely on promoting math and science achievement, while also nurturing interest in STEM through curricular activities (e.g., science experiments, competitions, computer classes). Postsecondary institutions generally expand access to STEM by identifying and recruiting students who meet admissions criteria and already have an interest in STEM. However, current K-12 STEM programs and focused undergraduate STEM student recruitment neglect students who may be interested in STEM bachelor's degree programs, but are underprepared for college level studies in these fields.

In this paper, we describe an online pre-matriculation mathematics intervention, the e-Math Forum, which was developed to expand access to STEM bachelor's degree programs at one university. The e-Math Forum was used to strengthen mastery of mathematics concepts considered critical for success in STEM degree programs. However, it also presents an opportunity for increase access to STEM among students that may not have otherwise been accepted to the institution, but who can succeed. This particular initiative involves collaboration among admissions, academic affairs, student support services, the mathematics department, and the Faculty Innovation in Teaching and Learning Center. In addition to describing the program, we also present preliminary data that suggests the intervention does expand access to STEM bachelor's degree programs, and in more ways than one.

# **Expanding access to engineering, science, and technology with an online pre-matriculation program**

## **I. Introduction**

There have been numerous calls to increase the number of students interested in, matriculating to, and graduating from science, technology, engineering, and mathematics (STEM) bachelor's degree programs [1,2]. In terms of expanding access at the K-12 level, stakeholders focus largely on promoting math and science achievement, while also nurturing interest in STEM through curricular activities (e.g., science experiments, competitions, computer classes). Postsecondary institutions generally expand access to STEM by identifying and recruiting students who meet admissions criteria and already have an interest in STEM. However, current K-12 STEM programs and focused undergraduate STEM student recruitment neglect students who may be interested in STEM bachelor's degree programs, but are underprepared for college level studies in these fields.

In terms of postsecondary entry, STEM academic programs maintain high admissions standards that effectively reduce the number of potentially eligible students in the pipeline. Although standardized achievement scores and high school grades may be good predictors of first-year college achievement, research shows that the relationship between these factors is mixed after considering ethnicity/race, gender, socioeconomic status, and institution type [3,4]. This suggests that promising students interested in STEM but who are considered underprepared may still be successful [5].

Further complicating the postsecondary STEM access is remediation, or lack thereof. In 2000, approximately one third of all first-year students needed remedial work in mathematics [6]. Despite this need, four-year institutions have significantly decreased (often by either State or Board mandate), and in many cases eliminated remedial coursework. Again, this limits access, as students that could potentially enter the STEM pipeline but lack the time and resources to strengthen basic skills (i.e., foundational mathematics and core science knowledge) are excluded.

Finally, work like Treisman's (1992) at the University of California, Berkeley has sought to address underprepared students who do matriculate to STEM bachelor's degree programs [7]. These structured support programs often focus on mathematics, providing students with resources to facilitate study groups, improve study skills, and other activities noted to promote persistence in STEM. These programs have proliferated throughout higher education, yet many students, both those considered prepared and those deemed underprepared, still leave STEM because of poor foundational knowledge of mathematics. In fact, "gateway" mathematics classes that are required for enrollment in more advanced coursework continue to pose a significant challenge to many students interested in and pursuing STEM bachelor's degree [8].

Despite efforts like Treisman's, the lack of remediation and traditional postsecondary recruitment strategies have effectively denied access to students potentially eligible for STEM bachelor's degrees or eliminated students interested in these fields due to resource deficits. In this paper, we describe an online pre-matriculation mathematics intervention, the e-Math Forum, which was developed to expand access to STEM bachelor's degree programs at one university.

The e-Math Forum was used to strengthen mastery of mathematics concepts considered critical for success in STEM degree programs. This particular initiative involves collaboration among admissions, academic affairs, student support services, the mathematics department, and the Faculty Innovation in Teaching and Learning Center. In addition to describing the program, we also present preliminary data that suggests the intervention does expand access to STEM bachelor's degree programs.

## **II. Background**

Polytechnic Institute of New York University (NYU-Poly) is a relatively small STEM-focused institution with fewer than 2,000 undergraduates. Among all undergraduates, approximately 80% are enrolled in engineering programs; the remainder matriculates into other STEM-related fields (e.g., Computer Science, Construction Management, Integrated Digital Media, Business and Technology Management). Despite NYU-Poly having a low proportion of female undergraduates on campus (approximately 20%), it is one of the most diverse institutions ethnically/racially. According to IPEDS, in 2010 the student body was comprised of 30% Asian/Pacific Islander, 26% White, 13% International, 12% Latina/o, and 10% African-American students [9]. In addition, NYU-Poly enrolls a large proportion of Pell-eligible students (41% in 2008-2009), which is significantly higher than the national average of low-income students enrolled in a private institution, making it an economically diverse institution as well. In terms of geography, well over half of all NYU-Poly students come from New York State and a large percentage from New York City.

Like most institutions, NYU-Poly has struggled with expanding access and promoting persistence in its undergraduate degree programs (all of which are in the STEM fields). In response, NYU-Poly began a "General Studies" (GS) program in 2004 to provide access to promising students that do not meet the desired academic standards for admission. The admissions office reads applicant files holistically using various applicant data points (including, but not limited to, standardized achievement scores, high school academic records, and essays) in determining whether students should be admitted to NYU-Poly through the GS program.

Students accepted into the 1-year GS program receive an array of services, beginning with a mandatory non-credit summer program prior to the start of their freshman year at no cost to the student. The program continues throughout the academic year with mandatory weekly tutoring and advisement sessions. Upon successful completion of the 1-year GS program (i.e., at least a 2.0 grade point average and a minimum of 24 earned credits), students are guaranteed full admittance into the University during their second year.

The GS summer program was designed to help bridge the gap between students' high school math, science, and writing skills, and those needed to navigate the rigorous undergraduate STEM curriculum at NYU-Poly. However, in past years some GS students continued to struggle academically after participating in the summer program, and especially in math courses. To address this, NYU-Poly developed a mandatory online summer math component in 2010 to introduce GS students to math at the college-level. The e-Math Forum was designed to increase student mastery of mathematics by providing an opportunity to review and deepen the mathematics they learned in high school.

A secondary goal of the GS online summer program was to provide an incentive for students from outside of the New York City area that could not attend the on-campus summer program. By participating in the e-Math Forum, these students have a chance to maintain their interest in matriculating to NYU-Poly by gaining a tangible understanding of the administrative and curricular expectations, but also developing relationships with their peers, and NYU-Poly faculty and staff.

### **III. Problem Statement**

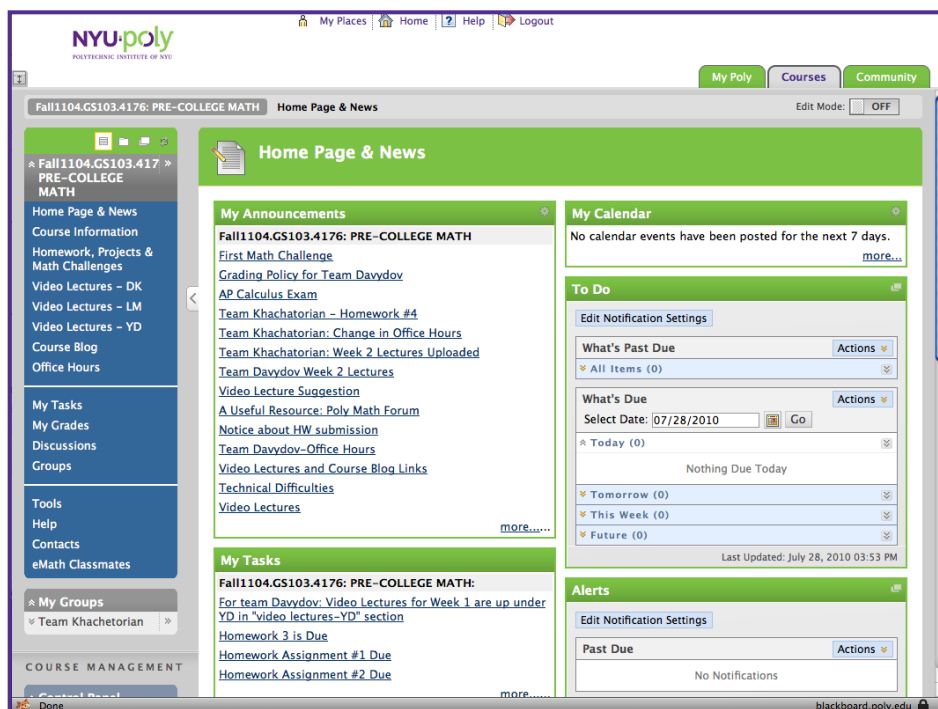
Students entering NYU-Poly in the first-year programs are typically placed in pre-Calculus, Calculus I, or Calculus II based on a placement exam and high school achievement information from their admissions application. While the institution strives to place students in the appropriate mathematics course, predicting their success is an imprecise endeavor. In addition, students often matriculate feeling confident in their own assessment of their ability, regardless of faculty and staff advice. This has contributed to many students, both those with and without exposure to advanced mathematics in high school, facing challenges related to inadequate understanding of foundational math. (It is important to note that there are other factors that may contribute to poor academic performance in mathematics including, but not limited to, poor study skills, hours spent at work, commuting, and an imbalanced course load.)

### **IV. Intervention Strategy**

The e-Math Forum presents an innovative approach to teaching and learning utilizing an online platform (see Figure 1). The e-Math Forum is a supplementary four-week program that provides GS students with access to full course content online using the Learning Management System, Blackboard and the virtual classroom tool, Wimba. All course communication, homework, sample exams, and quizzes are posted on Blackboard to facilitate access to and engagement with math coursework. For example, video lectures are provided online for students to view through Blackboard and their portable electronic devices (e.g., smart phones, iPads, and netbooks) (see Figure 2). In addition, students have access to a daily 6-hour online office hour to engage in and solve assigned problems with instructors using the chat and audio functionality in Wimba.

Student grades for the e-Math Forum component of the summer program are contingent upon homework completion, math challenges, and team assignment grades (as noted in Figure 1). Students are placed into six teams for group-work based on their SAT scores and grades in high school math courses. Specifically, there are 4 weekly homework assignments with about 10 questions each, and 1 math challenge team assignment.

Figure 1: Example e-Math Forum homepage screen shot



## V. Results

In the 2010 pilot cohort, 91 students participated in the online GS e-Math Forum, and 98% successfully completed the program. In terms of math course placement after the e-Math Forum, students were placed in Pre-Calculus (61%), Calculus I (38%), and Calculus II (1%) during their first year. As of September 2011, approximately 70% of the pilot cohort that successfully completed the online GS e-Math Forum, matriculated through the 1-year GS program, *and* are currently enrolled at NYU-Poly for the fall 2011 semester.

In the 2011 cohort, 60 students successfully completed the e-Math Forum, and 90% of these students matriculated to NYU-Poly in the 1-year GS program starting in the fall 2011 semester. Among those students who matriculated, 75% entered Pre-Calculus and 25% entered either Calculus I or II.

Figure 2: Example screen shot of e-Math Forum video lecture notes

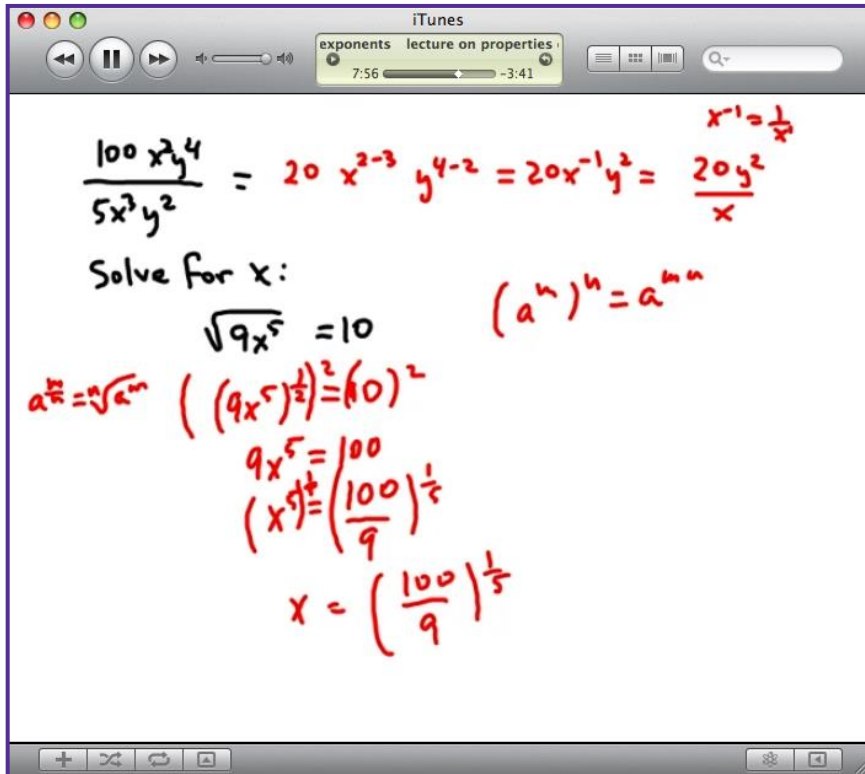
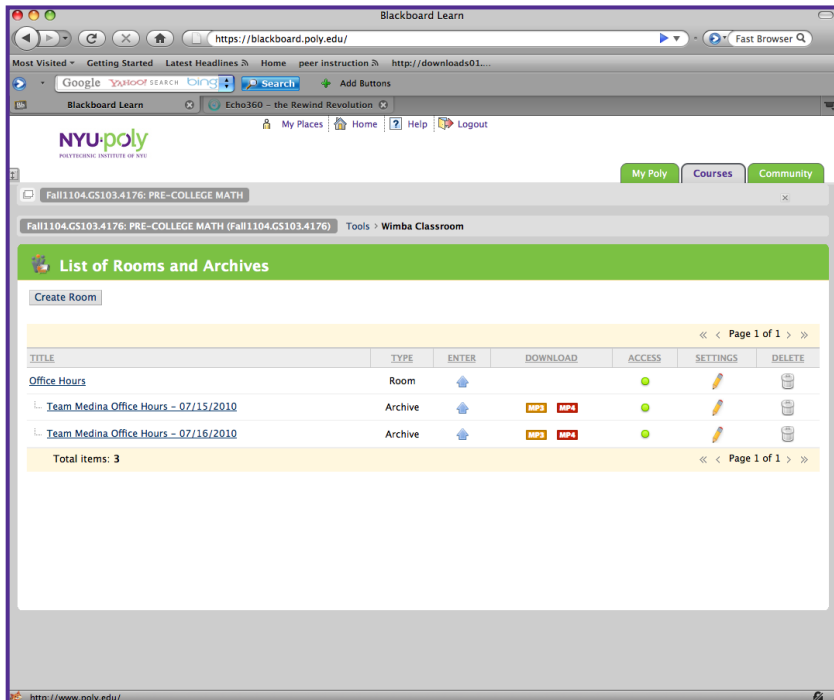


Figure 3: Example screen shot of e-Math Forum Rooms and Archives



## VI. Conclusions

The e-Math Forum highlights the possibilities and complexity of expanding access to STEM given the necessary collaboration across organizational units at NYU-Poly.

The success of the e-Math Forum can be measured by the number of students successfully completing the program, matriculating into the 1-year GS program, *and* subsequently enrolling as a regular full-time NYU-Poly student beginning in their second year. In effect, the 59 students from the 2010 online GS program who are enrolled as second-year students in STEM bachelor's degree programs at NYU-Poly represent students that would not have been admitted or enrolled without the e-Math Forum. These preliminary results suggest that the e-Math Forum can propel underprepared and underserved students into college-level mathematics courses and subsequently STEM bachelor's degree programs.

In the future the e-Math Forum will also be evaluated with reference to: a) improvement in student preparation for gateway mathematics courses, and b) persistence through NYU-Poly STEM degree programs.

We may also consider the benefits of expanding the e-Math Forum to all admitted NYU-Poly students, adding a physics curriculum, evaluating it as recruitment tool for students living outside of New York City, and conducting cost-benefit analyses.

### References

1. National Science Foundation, Division of Science Resources Statistics (2009). *Women, Minorities, and Persons with disabilities in science and engineering*, NSF 09-305, Arlington, VA. Retrieved from <http://www.nsf.gov/statistics/wmpd/>
2. Hill, C., Corbett, C., & St. Rose, A. (2010). *Why So Few? Women in Science, Technology, Engineering, and Mathematics*. American Association of University Women: Washington, DC. Retrieved from <http://www.aauw.org/learn/research/upload/whysofew.pdf>
3. Lord, S.M, Camacho, M.M., Layton, R.A., Long, R.A., Ohland, M.W., & Washburn, M.H. (2009). Who's persisting in engineering? A comparative analysis of female and male Asian, Black, Hispanic, Native American and White students. *Journal of Women and Minorities in Science and Engineering*, 15, 167-190.
4. Donaldson, K., Lichtenstein, G., & Sheppard, S. (2008). Socioeconomic status and the undergraduate engineering experience: Preliminary findings from four American universities. Paper presented at the 2008 ASEE National Conference. Retrieved from <http://soa.asee.org/paper/conference/paper-view.cfm?id=7691>
5. Carmichael, J.W., Labat, D.D., Hunter, J.T., Privett, J.A., & Sevenair, J.P. (1993). Minorities in the biological sciences- The Xavier success story and some implications. *BioScience*, 43(8), 564.
6. Duncan, H. and Dick, T. (2000). Collaborative Workshops and Student Academic Performance in Introductory College Mathematics Courses: A Study of a Treisman Model Math Excel Program. *School Science and Mathematics*, 100, 365-373.
7. Treisman, U. (1992). Studying students studying calculus: A look at the lives of minority mathematics students in college. *College Mathematics Journal*, 23(5), 362-372.
8. Thiel, T., Peterman, S., & Brown, M. (2008). Addressing the crisis in college mathematics: Designing courses for student success. *Change*, 40(4), 44-49.
9. National Center for Education Statistics. (2011). *Integrated Postsecondary Education Data System*. Washington, DC: U.S. Department of Education, Institute of Education Sciences.

## **Engineering Technology Program Development for Industry**

Harvey Lyons, Ph.D., P.E.  
Professor  
Mechanical Engineering Technology  
School of Engineering Technology  
Eastern Michigan University  
Ypsilanti, MI 48197  
734-487-2040  
hlyons@emich.edu



## **ENGINEERING TECHNOLOGY**

### **Program Development for Industry**

In the mid-eighties at Alfred University and in the early nineties at the Indiana Institute of Technology <sup>9</sup>, the writer implemented freshmen programs in the curriculum to address the lack of connectivity between the topics in basic science and introductory engineering technology courses. The entering students were exposed to a multi-dimensional course whose basic purpose was to efficiently provide not only an understanding of what is involved in the ‘design process’ performed in industry but also the *opportunity* to employ and develop those design functions and skills at the very outset of the students’ undergraduate experience. The several components of the course were integrated to include:

- Use of technical resources
- Technical report writing and oral delivery
- Research into the functions of technical societies
- Comprehensive discussions of fundamental manufacturing processes followed by design projects that would employ a given process towards the redesign of an existing part.
- Visits to local industries and talks with working technologists.
- Discussions about current and projected technology

These activities were designed to enable the development of a wide variety of open-ended design projects within a group format. Each project provided a creative opportunity for students and required progress reports, oral group activity and a comprehensive, chronological development culminating in a written report with full graphical and bibliographic elements.

We take the approach that design is a creative endeavor, leavened with logic and tempered by experience. Further, it is felt that it is inappropriate to wait until the student has accumulated ‘design information’ in subsequent (higher level) courses – we can design now! And we proceed with that concept by introducing several comprehensive design projects, organized in group format, developed by specifications, limited in time, but essentially *open-ended*. Now, in order to design, a student needs some basic tools with which to work. We feel that those tools most fundamental to the design process are: the communications skills and the graphical skills. For the former, it is essential to be able to clearly enunciate ideas in both oral and written form. For the latter, it is imperative that one be able to clearly and completely depict an idea *in order that it can be implemented*.

Subsequently, at Eastern Michigan University, the writer developed the *Introduction to Engineering Technology* course <sup>7</sup> which is designed to enable the entering freshmen to fully participate in the activities of an ET via a wide variety of projects that are carefully designed to illustrate the kinds of projects that are serviced by engineering technologists <sup>6</sup>. The activities that ensue serve as a vehicle for motivating students to pursue a clearer understanding of the factors that drive technology. Our initial objective is to make the students particularly aware of the importance of working effectively in a group, because that is the way things are commonly done in the professional world. Some of the things that are discussed include: that it is essential for all group members to establish a harmonious relationship; that it is essential for all group members to provide a reasonably equivalent effort; and that it is essential for all members to seek a common goal, namely, a quality effort within the time period specified. It is urged, that if someone in the group is not providing an equivalent amount of effort, the initial approach would

be to discuss it with that person. If that doesn't work, then the instructor should be notified. We have found this approach to work effectively.

Our next objective is to develop the procedures that effectively implement an open-ended design project. The following procedures are discussed, with accompanying handouts:

- Clearly Define the Effort. Make sure all the requirements are fully and clearly understood
- Identify all the Components. If all sizes and/or specifications are not fully provided, then establish them, with the understanding that they may be subject to change as the project develops.
- Find out About Items that are Not Clearly Understood. Use available sources.
- Develop Several Preliminary Ideas.
- Continue to Refine the Preliminary Ideas. At some early point in the design process, develop a time schedule and a design procedure.
- Consider the Organization of Your Group. It is of value to select a group leader who is sincerely motivated to develop the project to a successful conclusion.
- Develop a Consistent Attitude. Work on the project in a consistent, methodical manner. A project is rarely developed and completed successfully if the activities are erratic and/or marginal.

The project design skills and learning aids developed at the onset of the student's experience can be readily adaptable in subsequent coursework. Further, the formative skills needed for the Capstone design course can be implemented via open-ended design projects introduced to complement the specific topic being covered. It is, of course, exceedingly valuable to the student if the educator has had industrial experience and can provide practical design opportunities based upon those encountered in the professional world<sup>8</sup>. Hence, these design skills and aids are extended throughout the curriculum and are developed, in particular, in the Junior year as part of the laboratory component in the Machine Design course. Here, the formative skills needed for the Capstone Senior Design project are further improved. Open-ended design projects are created to complement the specific mechanical element – or topic – being covered. The purposes of these problems are twofold: (1) to understand, use and become proficient in the 'design process'; and (2) to explore, discover and learn a relatively basic yet significant facet of engineering technology as it is practiced. A detailed design report is required and can include: title; table of contents; introduction; technical body with sketches, figures, tables, chronological development; results; conclusions/recommendations; appendix; and references. Preference may be given to report development on a group basis to continue to learn how to work in an effective and contributory way with other members. It is notable that the students readily participated in the design projects and, overall, developed reports that exhibited a sincere and motivated effort. The student is now ready to address a more comprehensive design project and can entertain the inclusion of a more sophisticated design methodology.

The goal at this juncture of the educational process is to create a product or process that will satisfy human needs with respect to function, aesthetics, quality and cost. Satisfying this goal will require an understanding of the interrelationship among concept, technical development and marketability; and integration of the technical and aesthetic skills towards development of an engineered product. The Senior Design Capstone Project<sup>5</sup> is an introduction to the methods of

interdisciplinary engineering via participation in a concentrated and accelerated engineering project. It is also a way to bridge the student-engineering professional gap. The objectives and some of the expected benefits of this course include:

- Experience an appreciation of the overall problems in carrying out the open-ended design of a typical complex engineering device or system.
- Enhance their creativity in a practical and dynamic environment.
- Work progressively and positively with others in a practical and scheduled manner.
- An opportunity to use and integrate material learned in earlier courses.
- An opportunity to develop the communication skills required of a professional engineer.
- More enthusiasm for Engineering Technology as a career.

The Mechanical Engineering Technology Capstone Program employs open-ended projects, all of which are developed and designed to benefit the community and, in a cooperative manner, instill leadership among the students that are engaged in this effort. Students are actively engaged in community service by offering their engineering and technological services to design and develop projects for use in both non-profits and small businesses. For example, one student project group offered their engineering services to the Veterans Affairs Hospital in Ann Arbor, Michigan, for assistance in the rehabilitation of wounded veterans. Their project was a Rehabilitation Therapy Walker. The Physical Therapist in the VA Hospital described the project's values and benefits in the magazine 'PT in Motion' <sup>1</sup> in which she wrote that '... when four undergraduate students at Eastern Michigan University approached her about a school project, she knew exactly what she wanted.' Further, '...the students were conscientious and listened well and they'd also listened to their professor who had suggested that they look at the VA Medical Center for projects that could help patients. Knock on some doors and see what you can do, he had advised. And when the opportunity knocked, I answered.'

The very nature of providing an engineering project for a sponsor promotes and develops leadership skills <sup>2</sup>. For example, the client/sponsor may propose a desired 'result' but generally is not familiar with the design stages that must be implemented to arrive at a suitable solution. Here is where the students must take the lead whereby they interact with a variety of sources – consultants, industry representatives and the like – in order to fully develop a satisfactory and cost-effective system. The development – and requirement – for leadership skills was particularly needed for a design project at a County Fairgrounds. Here, a student's father notified his daughter – an MET senior design student – that there was an urgency to replace the current thirty-year old, steam-powered locomotive at the Fairgrounds. The student design team learned that the facility favored a diesel-powered locomotive that would carry fair-goers for years to come. As was expected, the fairground committee had no specific solution in mind, so the students had to take the leadership role and introduce a variety of concepts and designs. The students not only fulfilled the design requirements within the Capstone period, they also built a prototype for display. In conclusion, the scope of leadership efforts included the necessary materials, tools, equipment, accessories and related costs.

The MET student is urged to reach out and work with one another collectively in group projects. The Capstone projects are team projects, providing the valuable opportunity to work progressively and positively with others in a practical and scheduled manner. Due to the fact that the Capstone projects have a client or sponsor, the students will learn to acquire skills for working cooperatively with the promoters of their project. The continuing interactions with

client/sponsor throughout the extended period of project development will promote improvement of those attributes required in a professional setting. The several oral and power point presentations, collectively witnessed by the students' peers, faculty and invited guests, enables a clear assessment of the acquired skills. It is noted that many of the invited guests are the sponsors of the projects being displayed and have the opportunity – and responsibility – to comment on the presentations. Thus, the MET Capstone Program provides the sustainable transition from student to professional by employing real-world project requirements within this program. And the ethical components that are particularly suited for a specific project are fully described in the students' Final Design Report <sup>4</sup>.

A significant concluding event that is held each spring at Eastern Michigan University is the Undergraduate Symposium. Here, undergraduate students from all academic departments may be nominated to display their exceptional academic work. Student presentations may be presented in oral or poster format and by single or multiple authors. Recently, a complete energy audit and analysis was performed for the College of Technology at Eastern Michigan University by MET Capstone students. It focused on five key areas to develop solutions to reduce energy consumption and thus save EMU money. The areas investigated were: lighting, HVAC, alternative energy sources, water usage and facilities. Cost-effective solutions were recommended to be implemented for the shortest payback period. Three student groups worked on this: one group developed an audit of the energy usage and determined energy savings and payback periods; another group gathered real-time utility usage that will allow facility managers to correlate performance with occupant load; and the third group designed a small unit that enables the user to monitor the amount of energy being used real-time. This project was displayed in the recent UG Symposium and reviewed by the Provost who was very pleased with the results.

We can effectively meet the needs of student and industry by providing the engineering technology student with a comprehensive design experience that closely matches that encountered by professional design engineers. We can seek to develop the communication and teaming skills that are an inherent and vital part of design activity and address the need to promote the creative capabilities of the entering student <sup>3</sup>.

#### Bibliography

1. Wojciechowski, m., *PT in Motion, Bright Ideas: PT's as Inventors*, p.22, February, 2011.
2. Lyons, H., *Engineering Technology Collaboration with Industry*. ASEE Mid-Atlantic Fall Conference, King of Prussia, Pennsylvania, October, 2009.
3. Lyons, H., *Globalization Trends in Engineering and Engineering Technology*. ASEE North Central Section Spring Conference, Grand Rapids, Michigan, April, 2009.
4. Lyons, H., *The Future Practice of Engineering*. ASEE Annual Conference and Exposition, Chicago, Illinois, June, 2006.
5. Lyons, H., Albayyari, J., *The Capstone Program – Experience for Industry*. ASEE North Central Section Spring Conference, Kalamazoo, Michigan, April, 2004.
6. Lyons, H., Albayyari, J., *Developing Engineering Technology Education for Professional Practice*. ASEE North Central Section Spring Conference, Columbus, Ohio, April, 2003.
7. Lyons, H., Albayyari, J., *Integrating the Freshman Experience: E.T. Design Projects*. ASEE North Central Section Spring Conference, Cleveland, Ohio, April, 2001.
8. Lyons, H., *The Industrial Design of Mechanical Engineering Technology*. ASME International Mechanical Engineering Congress and Symposium, Nashville, Tennessee, November, 1999.

9. Lyons, H., Messick, G., *Science and Engineering Design Projects: Connecting and Integrating the Freshman Experience*. ASEE/IEEE Frontiers in Education, Johns Hopkins University, November, 1993.

## **The Formation of Supported Gold Nanostructures on Oxide Substrates Invited**

Melissa P. Mackinnon  
Department of Mechanical Engineering,  
Temple University, Philadelphia, PA 19122

Kyle D. Gilroy  
Department of Mechanical Engineering,  
Temple University, Philadelphia, PA 19122

Aarthi Sundar  
Department of Mechanical Engineering,  
Temple University, Philadelphia, PA 19122

Robert Hughes  
Department of Mechanical Engineering,  
Temple University, Philadelphia, PA 19122

Svetlana Neretina  
Department of Mechanical Engineering,  
Temple University, Philadelphia, PA 19122

# The Formation of Supported Gold Nanostructures on Oxide Substrates

Melissa P. Mackinnon, Kyle D. Gilroy, Aarthi Sundar, Robert Hughes and Svetlana Neretina

Department of Mechanical Engineering, Temple University, Philadelphia, PA 19122

## Abstract

Gold nanoparticles were produced using the solution-based synthetic protocols devised by Murphy and coworkers. These nanoparticles, which are 4 nm in diameter, were then dispersed onto an oxide substrate. The nanoparticles, which originally showed weak adhesion to the substrate, were then heated to temperatures approaching their melting point. This anneal resulted in nanoparticle adhesion strong enough to withstand aggressive sonication and swabbing. The strong adhesion is highly suggestive of the formation of a heteroepitaxial relationship capable of crystallographically aligning all nanoparticles in a single orientation. The nanoparticles also show a size reduction of 1 nm after the anneal which we attribute to a nanoparticle shape change, the loss of gold along the substrate due to surface diffusion and the destruction of the capping layer. These substrate-based nanoparticles should prove quite effective as seed materials for the nucleation of larger nanostructures with a higher degree of complexity.

## 1. Introduction and Motivation

While the vast majority of gold nanostructures have been produced using solution-based synthetic protocols, it is well-understood that a significant number of potential applications require that the nanostructures be supported by a substrate in a manner which renders them immobile. As an example, two dimensional nanoparticle arrays have attracted significant attention due to their applications in sensors<sup>1,2</sup> information storage<sup>3,4</sup> nanomaterial fabrication<sup>5,6</sup> bioseparation<sup>7</sup> and catalysis<sup>8,9</sup>. Nanomaterials also exhibit attractive properties in electrode modification by enhancing the electrode conductivity, facilitating the electron transfer and improving the analytical sensitivity and selectivity<sup>10</sup>.

Oxide substrates have proved particularly effective in the production of supported metallic nanostructures due to their chemical and thermal stability, crystallographic perfection, and the wide variety of accessible surface reconstructions. Numerous routes have been devised for the fabrication of supported nanostructures including the attachment of functionalized solution-based nanoparticles to the surface<sup>11</sup>, growth off of surfaces seeded with linked nanoparticles<sup>12</sup>, lithographically patterning continuous thin films<sup>13</sup>, thermal dewetting<sup>14</sup>, spinodal dewetting<sup>15</sup>, microwave plasma-induced dewetting<sup>16</sup>, vapor phase epitaxy<sup>17</sup> and nanosphere lithography<sup>18</sup>. Among these techniques, the attachment of functionalized solution-based nanoparticles to the substrate surface provides distinct advantages in terms of nanoparticle size control and uniformity.

Gold nanoparticles are generally dispersed onto surfaces using various linkers such as thiols<sup>19,20</sup>, aminopropyltrimethoxysilane (APTMS)<sup>21</sup>, mercaptopropyltrimethoxysilane (MPTMS)<sup>22,23</sup>, mercaptohexadecanoic acid (MHA)<sup>24</sup> and poly-l-lysine<sup>25</sup>. These nanoparticles, however, are encapsulated in a capping agent which limits their functionality and disrupts the plasmonic and catalytic properties<sup>26</sup>. Moreover, for some applications (e.g. electrode surface modification with nanoparticles) it is reasonable to expect that the binder molecules significantly

influence, not only the nature of the nanomaterials, but also the surface properties of the substrate<sup>27</sup>. Here, we describe an approach to mitigate these issues where we first disperse nanoparticles having capping agents onto a surface and then destroy the capping layer using a high temperature anneal near the melting point of the nanoparticle. The resulting recrystallization also creates the opportunity to engineer the shape and crystallographic orientation of the nanostructures through substrate imposed strains, heteroepitaxy, crystallographic symmetries, substrate surface morphology, interface chemistry and wettability<sup>27</sup>.

## 2. Experimental Section

**2.1 Chemicals.** DI-water HPLC Grade, Hydrogen tetrachloroaurate(III) trihydrate ( $\text{HAuCl}_4 \cdot 3\text{H}_2\text{O}$ , 99.9+%), trisodium citrate dihydrate (99%), sodium borohydride ( $\text{NaBH}_4$ , 99%), and L ascorbic acid ( $\text{C}_6\text{H}_8\text{O}_6$ , 99+%), Acetone (99+%), cetyltrimethylammonium bromide ( $\text{C}_{16}\text{TAB}$ , 98%) to achieve the acquired concentrations of  $\text{C}_{16}\text{TAB}$ , which is heated to 50°C and then cooled to room temperature.

**2.2 Instrumentation.** Annealing processes were carried out using Thermo Scientifics Lindberg Blue M furnace. The synthesized colloidal gold nanoparticles were characterized using absorption spectroscopy (JASCO UV-VIS spectrometer). Veeco's Multimode AFM was used for measuring the radius of the gold nanostructures before and after annealing. The probe used in these images was the NSC15/noAl purchased from Mikromasch.

**2.3 Nanostructure Synthesis.** Gold nanostructures were fabricated using the seed-mediated synthetic protocol developed by Murphy and co-workers<sup>29</sup>. The basic synthesis of gold nanoparticles includes the reduction of a gold salt solution, chloroauric acid ( $\text{HAuCl}_4$ ), with a sodium citrate reducing agent. The  $\text{Au}^{3+}$  ions formed in the solution are reduced to neutral gold  $\text{Au}^0$  atoms. These atoms then form nuclei which act as nucleation sites for the nanoparticles which grow in size until the supply of gold ions is exhausted. The seed-mediated growth of gold nanoparticles began with the preparation of three solutions: (i) 5 mL of 0.01M  $\text{HAuCl}_4 \cdot 3\text{H}_2\text{O}$  (ii) 4 mL of 0.01 M trisodium citrate and (iii) 4 mL of 0.01 M sodium borohydride. After preparation, the sodium borohydride solution was cooled to ice-cold temperatures. Also note that all solutions were used within one hour of their synthesis. Next, 18.4 mL of ultra pure deionized (DI) water was mixed with 0.5 mL 0.01 M  $\text{HAuCl}_4 \cdot 3\text{H}_2\text{O}$  and 0.5 mL 0.01 M trisodium citrate in a 50 mL beaker, while stirring. Lastly, 0.6 mL of 0.1 M sodium borohydride was injected into the solution while mixing vigorously for 2 minutes. The injection resulted in an immediate color change from a light gold to an orange/pink color. After 3 minutes the solution turned light purple with a wavelength absorption maximum at 520 nm. The nanoparticles produced are spherical in shape and have diameters ranging from 3-4 nm. After 10 hours, however, the nanoparticles became unstable to agglomeration, resulting in a clear solution with black precipitates.

**2.4 Coating the Sapphire Substrate.** Sapphire substrates, approximately 1 cm x 1 cm, were cleaned with ethanol, rinsed with dionized water and dried in nitrogen. Once dry, the substrates were dip-coated in the nanoparticle solution and placed on a hotplate at 60° C for 15 min where



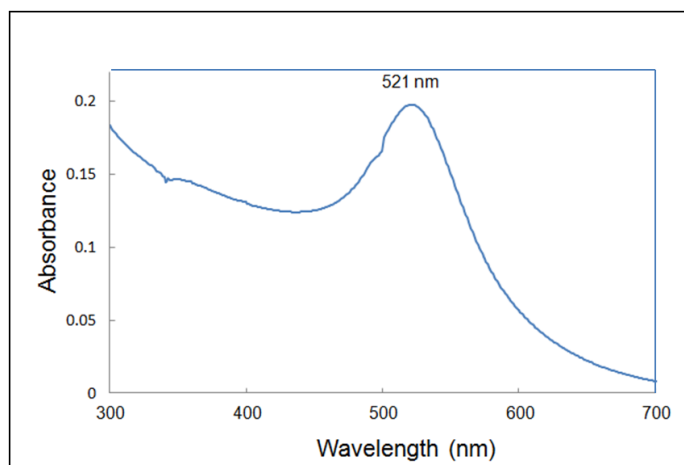
they were allowed to dry. The nanoparticles were then characterized using atomic force microscopy.

**2.5 Annealing of Gold Nanoparticles.** Substrates coated with gold nanoparticles were then annealed in a furnace to temperatures approaching the melting point of the gold nanoparticle. It should be noted, however, that for a 4 nm diameter gold nanoparticle the melting point is reduced from its bulk value of 1064 °C by approximately one-half<sup>30</sup>. The annealing regimen was, thus, chosen to be 2 hours at 375 °C. Once removed from the annealing furnace, the samples were sonicated for 3 minutes to ensure that the annealed nanoparticles were firmly affixed to the substrate. These samples were then placed on a hot plate at 60°C until dry.

### 3. Results

#### 3.1 Absorption Spectroscopy

Figure 1 shows the absorption spectrum of the nanoparticle solution measured immediately after synthesis. The absorbance maximum at 521 nm is identical to the value obtained by Murphy and coworkers<sup>29</sup> when first establishing this synthetic protocol.

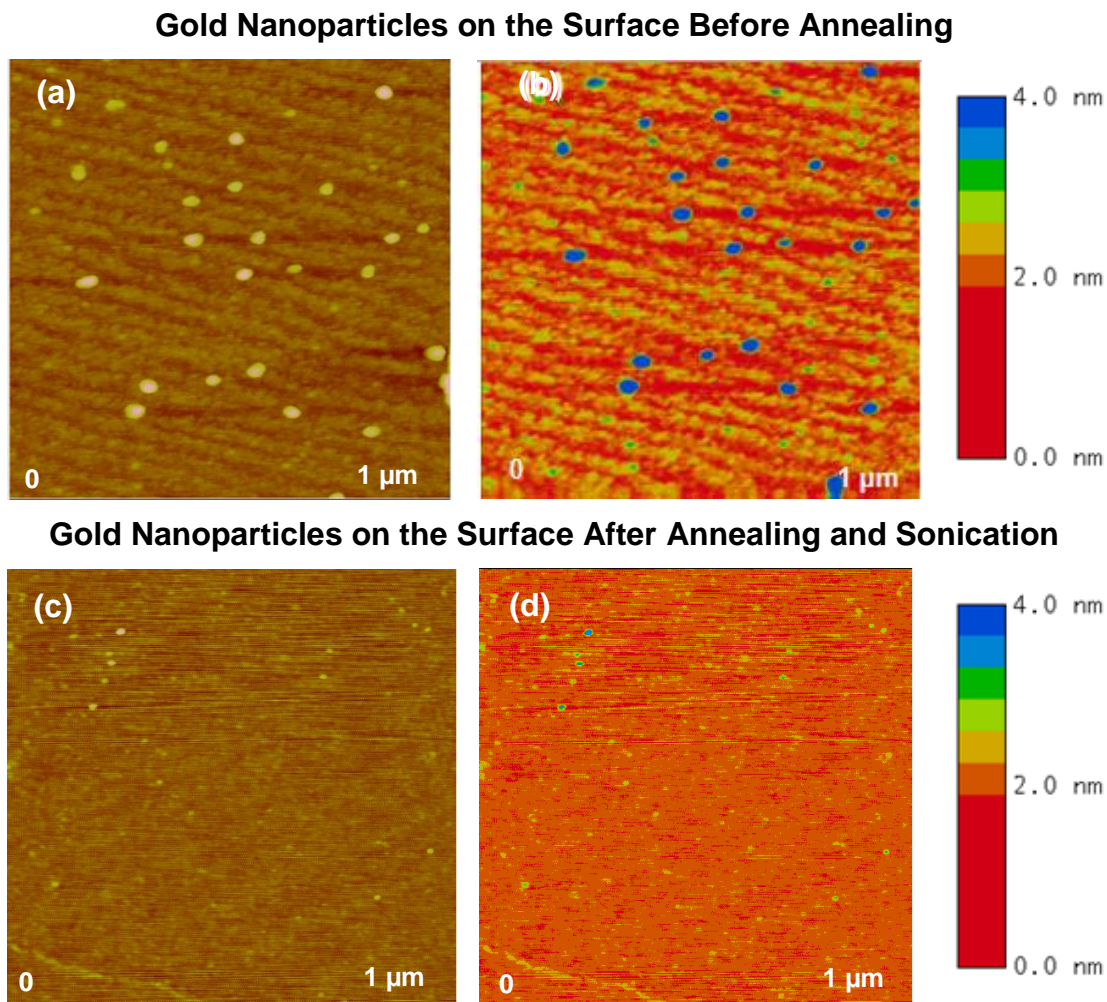


**Fig. 1** The absorbance spectrum of gold nanoparticle in solution. The peak absorbance is at 521 nm.

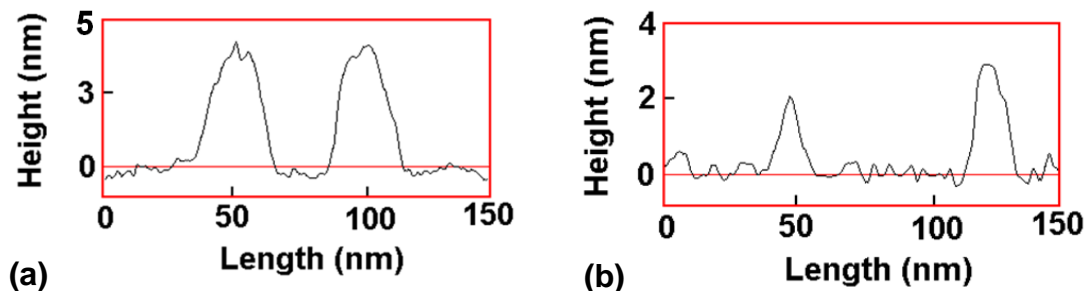
#### 3.2 Atomic Force Microscopy

The atomic force microscope was used to image the gold nanoparticles before and after annealing (Fig. 2). Figures 2b and 2d are color maps showing the gold nanoparticle height distribution. From these maps it is apparent that the nanoparticles maintain a narrow height distribution after annealing, but where the nanoparticle diameter has been reduced from 3-4 nm to 2-3 nm. Note that the density of the nanoparticles has not been altered by the anneal. This size reduction is also apparent from the gold nanoparticle cross-sections shown in Fig. 3 for nanoparticles formed before (Fig. 3a) and after (Fig. 3b) the annealing procedure. We attribute the 1 nm size reduction to the loss of the capping material, gold surface diffusion along the

substrate and to the fact that the recrystallization process gives rise to a shape change from spherical to near-hemispherical. Large area scans revealed vast fields of these nanoparticles with a few scattered regions showing agglomerated clusters.

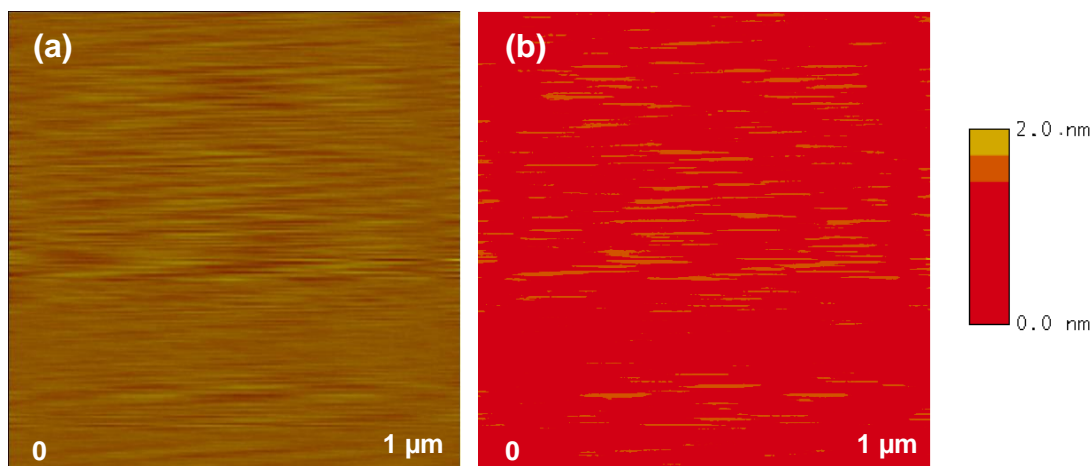


**Fig. 2** AFM images showing a comparison of gold nanoparticles on the surface of sapphire (a) before and (c) after annealing. Also presented are the corresponding color maps showing the nanoparticle height distributions (b) before and (d) after annealing. Note that the size distribution remains narrow after annealing, but where the average height has decreased by 1 nm.



**Fig. 3** Comparison of the cross-sections of gold nanoparticles on the surface of sapphire (a) before and (b) after annealing. Note that the height of the nanoparticles decreased from (a) 4 nm to (b) 3 nm.

In order to demonstrate the adhesion gained by the gold nanoparticles during the annealing process, nanoparticles were placed on a sapphire substrate and then sonicated for 3 minutes without undergoing the annealing process. Figures 4a and 4b shows the equivalent topographic image and height distribution color map to those shown in Figs. 2c and 2d. Note that no nanoparticles appear in these images. This is a clear indication that the dip-coated gold nanoparticles are loosely bound to the surface of the substrate and were easily removed during the sonication process. This is in stark contrast to annealed nanoparticles, which survive both aggressive sonication and swabbing.



**Fig. 4** AFM image showing the (a) topographic and (b) height distribution color maps for a substrate surface covered in gold nanoparticles and then exposed to 3 minutes of sonication. Note that no nanoparticles adhere to the surface.

#### 4. Discussion

The results of this study demonstrate the effectiveness of affixing substrate-based gold nanoparticles to the surface of oxide substrates using a high temperature anneal. It also lays the foundation for subsequent experiments aimed at using these gold nanoparticles as seeds for the growth of larger substrate-based nanostructures with a higher degree of complexity. One intriguing possibility is to expose these seeds to a solution which promotes the growth of gold nanorods<sup>31</sup>. Numerous studies have shown the viability of producing nanorods using spherical

gold nanoparticle seeds affixed to the surface using linkers. These seeds, however, give rise to low nanorod yields and where the nanorod direction is random. This is not unexpected when it is realized that the crystallography of the seed determines if and in which direction the nanorod emerges. By recrystallizing the seeds on a substrate it is likely that all seeds have the same crystallographic orientation due to the heteroepitaxial relationship formed with the substrate. If this relationship is chosen appropriately then identical and aligned nanorods should emerge from these seeds, a prospect which would enable detector technologies based on these structures.

## 5. Conclusion

Solution-based gold nanoparticles were dispersed on an oxide substrate and subsequently annealed to high temperatures. The heating regimen reduced the nanoparticle size and resulted in strong adhesion to the substrate. The nanostructures produced will be used as seed material for the fabrication of more complex nanostructures.

### Acknowledgements:

This work was funded by the start-up funds of Dr. Neretina. MPK and KDG acknowledge the financial support of the NSF NUE grant No 1042071. We also acknowledge Dr. M. Kiani and Dr. R. Suri for providing access to their respective facilities and Dr. Baran for providing access to the AFM instrument.

### References

- (1) A. J. Haes, L. Chang, W. L. Klein, R. P. Van Duyne, Detection of a biomarker for Alzheimer's disease from synthetic and clinical samples using a nanoscale optical biosensor, *J. Am. Chem. Soc.* **127**, 2264-2271 (2005).
- (2) A J. Haes, R. P. Van Duyne, A unified view of propagating and localized surface plasmon resonance biosensors, *Anal. Bioanal. Chem.* **379**, 920-930 (2004).
- (3) M. Chen, J. Kim, J. P. Liu, H. Y. Fan, S. H. Sun, Synthesis of FePt nanocubes and their oriented self-assembly, *J. Am. Chem. Soc.* **128**, 7132-7133 (2006).
- (4) S. H. Sun, Recent advances in chemical synthesis, self-assembly, and applications of FePt nanoparticles, *Adv. Mater.* **18**, 393-403 (2006).
- (5) D. Gao, R. R. He, C. Carraro, R. T. Howe, P. D. Yang, R. Maboudian, Selective growth of Si nanowire arrays via galvanic displacement processes in water-in-oil microemulsions, *J. Am. Chem. Soc.* **127**, 4574-4575 (2005).
- (6) Greyson, E. C.; Babayan, Y.; Odom, T. W., Directed growth of ordered arrays of small-diameter ZnO nanowires, *Adv. Mater.* 2004, 16, 1348-1352.
- (7) B. Q. Li, X. H. Fang, H. B. Luo, Y. S. Seo, E. Petersen, Y. Ji, M. Rafailovich, J. Sokolov, D. Gersappe, B. Chu, Separation of DNA with different configurations on flat and nanopatterned surfaces, *Anal. Chem.* **78**, 4743-4751 (2006).
- (8) A. M. Contreras, J. Grunes, X. M. Yan, A. Liddle, G. A. Somorjai, Fabrication of 2-dimensional platinum nanocatalyst arrays by electron beam lithography: ethylene hydrogenation and CO-poisoning reaction studies, *Top. Catal.* **39** 123-129 (2006).

- (9) S. Kwon, X. M. Yan, A. M. Contreras, J. A. Liddle, G. A. Somorjai, J. Bokor, Fabrication of metallic nanodots in large-area arrays by mold-to-mold cross imprinting (MTMCI), *Nano Lett.* **5**, 2557-2562 (2005).
- (10) E. Katz, I. Willner, J. Wang, Electroanalytical and Bioelectroanalytical Systems Based on Metal and Semiconductor Nanoparticles, *Electroanalysis* **16**, 19 (2004).
- (11) C. Sönnichsen, B. M. Reinhard, J. Liphardt, A. P. Alivisatos, A molecular ruler based on plasmon coupling of single gold and silver nanoparticles, *Nat. Biotechnol.* **6**, 741-745 (2005).
- (12) N. P. W. Pieczonka, R. F. Aroca, Single molecule analysis by surfaced-enhanced Raman scattering, *Chem. Soc. Rev.* **5**, 946-954 (2008).
- (13) L. Billot, M. Lamy de la Chapelle, A. S. Grimault, A. Vial, D. Barchiesi, J. L. Bijeon, P. M. Adam, P. Royer, Surface enhanced Raman scattering on gold nanowire arrays: Evidence of strong multipolar surface plasmon resonance enhancement, *Chem. Phys. Lett.* **4-6**, 303-307 (2006).
- (14) C. R. Henry, Morphology of supported nanoparticles, *Prog. Surf. Sci.* **3-4**, 92-116 (2005).
- (15) S. J. Henley, J. D. Carey, S. R. P. Silva, Pulsed-laser-induced nanoscale island formation in thin metal-on-oxide films, *Phys. Rev. B* **72**, 195408 (2005).
- (16) C. Y. Hsu, J. W. Huang, S. Gwo, K. J. Lin, The facile fabrication of tunable plasmonic gold nanostructure arrays using microwave plasma, *Nanotechnology* **21**, 035302 (2010).
- (17) F. Silly, M. R. Castell, Bimodal growth of Au on SrTiO<sub>3</sub>(001), *Phys. Rev. Lett.* **96**, 086104 (2006).
- (18) C. L. Haynes, R. P. Van Duyne, Nanosphere lithography: A versatile nanofabrication tool for studies of size-dependent nanoparticle optics, *J. Phys. Chem. B* **105**, 5599-5611 (2001).
- (19) K. C. Grabar, K. R. Brown, C. D. Keating, S. J. Stranick, S. L. Tang, M. J. Natan, Nanoscale characterization of gold colloid monolayers: A comparison of four techniques, *Anal. Chem.* **69**, 471 (1997).
- (20) J. A. Harnisch, A. D. Pris, M. D. Porter, Attachment of gold nanoparticles to glassy carbon electrodes via a mercaptobenzene film, *J. Am. Chem. Soc.* **123**, 5829 (2001).
- (21) N. Taub, O. Krichevski, G. Markovich, Growth of gold nanorods on surfaces, *J. Phys. Chem.* **107**, 11579-11582 (2003).
- (22) N. Taub, O. Krichevski, G. Markovich, Growth of gold nanorods on surfaces, *J. Phys. Chem.* **107**, 11579-11582 (2003).
- (23) Z. Wei, F. P. Zamborini, Directly monitoring the growth of gold nanoparticle seeds into gold nanorods, *Langmuir* **20**, 11301-11304 (2004).
- (24) A. Gole, C. J. Orendorff, C. J. Murphy, Immobilization of gold nanorods onto acid-terminated self-assembled monolayers via electrostatic interactions, *Langmuir* **20**, 7117-7122 (2004).
- (25) H. Liao, J. H. Hafner, Monitoring gold nanorod synthesis on surfaces, *J. Phys. Chem. B* **108**, 19276-19280 (2004).

- (26) C. J. Murphy, L. B. Thompson, A. M. Alkilany, P. N. Sisco, S. P. Boulos, S. T. Sivapalan, J. A. Yang, D. J. Chernak, J. Huang, The many faces of gold nanorods, *J. Phys. Chem. Lett.* **1**, 2867-2875 (2010).
- (27) G. A. Devenyi, J. Li, R. A. Hughes, A.-C. Shi, P. Mascher, J. S. Preston, The epitaxially driven formation of intricate supported gold nanostructures on a lattice-matched oxide substrate, *Nano Lett.* **9**, 4258-4263 (2009).
- (28) A. Yu, Z. Liang, J. Cho, F. Caruso, Nanostructured electrochemical sensor based on dense gold nanoparticle films, *Nano Lett.* **3**, 1203 (2003).
- (29) N. R. Jana, L. A. Gearheart, C. J. Murphy, Seed-mediated growth approach for shape-controlled synthesis of spheroidal and rod-like gold nanoparticles using a surfactant template, *Adv. Mater.* **13**, 1389-1393 (2001).
- (30) Ph. Buffat, J-P. Borel, Size effect on melting temperature of gold particles, *Phys. Rev. A* **13**, 2287-2298 (1976).
- (31) B. Nikoobakht, M. A. El-Sayed, Preparation and growth mechanism of gold nanorods (NRs) using seed-mediated growth method, *Chem. Mater.* **15**, 1957-1962 (2003).

**Professional Science Master's Programs:  
An Opportunity for Engineering Schools and Students**

Beverly Karplus Hartline, Ph.D.

Acting Dean of Engineering and Applied Sciences,  
Associate Provost for Research,  
Dean of Graduate Studies, University of the District of Columbia

**Professional Science Master's Programs:  
An Opportunity for Engineering Schools and Students**

**Beverly Karplus Hartline, Ph.D.**

Acting Dean of Engineering and Applied Sciences,  
Associate Provost for Research,  
Dean of Graduate Studies, University of the District of Columbia

The Professional Science Master's (PSM) degree prepares students with a strong foundation in natural science, computation, engineering, and/or mathematics for a broad range of professional career options in business, industry, government, and non-profit organizations.

Each PSM is an innovative degree program, designed in close consultation with interested employers, in which the students undertake an internship or team project, rather than a thesis or comprehensive exam. The PSM curriculum combines rigorous graduate-level coursework in science, engineering, computer science, and/or mathematics with workplace-oriented coursework in management, communications, law, marketing, entrepreneurship, or other, so-called "plus" fields. In 2010, the PSM scope was broadened to include engineering-based specialties, though not aimed toward professional licensure or certification. PSM degrees are offered in such specialties as bioinformatics, nanomaterials, science/engineering entrepreneurship, water resources, and renewable energy, among others. Graduates are well paid and in high demand.

UDC leads the HBCU Mid-Atlantic PSM Alliance, and was the first HBCU to join the ranks of PSM institutions. This presentation will introduce the PSM, the process for curriculum development with industry, and the myriad opportunities for engineering-based PSM that spur employment, economic development, and business partnerships in the broad region around any campus.



## **SECTION 5**

## **Undergraduate Research in Healthcare Packaging**

Siripong Malasri  
Packaging Activities & Healthcare Packaging Consortium Coordinator,  
Christian Brothers University,  
650 East Parkway South, Memphis, TN 38104,  
[pong@cbu.edu](mailto:pong@cbu.edu)

### **SIRIPONG MALASRI**

Siripong Malasri, Ph.D., P.E., is a Professor of Civil Engineering at Christian Brothers University, where he also serves as Packaging Activities & Healthcare Packaging Consortium Coordinator. He obtained his Ph.D. from Texas A&M University and is a registered professional engineer in Tennessee. Dr. Malasri was instrumental to the establishment of the packaging engineering program at CBU during his term as engineering dean from 1999-2005. His background includes construction management, structural engineering, solid mechanics, materials testing, artificial intelligence, and optimization. He is a member of IoPP, TAPPI, and NSPE. He can be reached at [pong@cbu.edu](mailto:pong@cbu.edu).

# Undergraduate Research in Healthcare Packaging

Sripong Anantwi<sup>1</sup>

**Abstract:** Christian Brothers University (CBU) is a primarily undergraduate institution with a focus on excellent teaching. Its engineering students usually obtain some undergraduate research experience through their senior design projects. However, many of these projects are routine design projects; thus, they do not contribute any new knowledge to the discipline. Unlike research institutions, it is not easy for a primarily teaching institution to develop undergraduate research that contributes new knowledge. Two factors have helped address this issue for CBU: the development of its undergraduate packaging program (including a certified packaging lab) and the establishment of a Healthcare Packaging Consortium. This paper discusses the needed infrastructure to make undergraduate research possible at primarily undergraduate teaching institutions, which includes meaningful projects, facilities, funding, and incentives for both faculty and students. It also illustrates the benefits students have received from this consortium project.

**Keywords:** Healthcare packaging research, undergraduate research, research in primarily teaching institutions, industry-sponsored projects

## Introduction

Christian Brothers University is a primarily undergraduate institution with four schools: the School of Art, School of Business, School of Engineering, and School of Science. It was founded in 1871 as Christian Brothers College. The electrical engineering program began in 1953 and was followed by mechanical engineering, civil engineering, and chemical engineering programs. Currently, these four undergraduate engineering programs are accredited by ABET. Recently, engineering management has been added to the four traditional engineering disciplines, with two concentrations in information technology and packaging. The School of Engineering has also offered a Master's degree in engineering management for over 20 years.

It was natural for CBU to develop a packaging program due to its location in Memphis, which has long been recognized as a major distribution center. FedEx's world headquarters has attracted many companies to place their distribution centers in Memphis. Meanwhile, Memphis International Airport has helped the city redefine itself as America's premier air-to-pole. According to the Greater Memphis Chamber ([www.memphischamber.com](http://www.memphischamber.com)):

- Memphis is home to the busiest air cargo airport in North America since 1992
- Memphis is on the path of I-40, the 3<sup>rd</sup> busiest trucking corridor in the U.S.
- Memphis has five Class I railroads passing through it: BNSF, CSX, Union Pacific, Norfolk Southern, and Canadian National
- The Port of Memphis is the fourth largest inland port in the U.S.
- 10.2% of the Memphis workforce is employed in transportation and utilities, the highest percentage among the top 100 largest metro areas in the U.S.

For these reasons, a packaging program located in Memphis is logical and rife with opportunities. CBU's undergraduate packaging education program [1] started with a packaging elective for engineering students in the spring of 2001, which has since grown into a Packaging Engineering Certificate and B.S. in Engineering.

---

<sup>1</sup> Packaging Activities & Healthcare Packaging Consortium Coordinator, Christian Brothers University, 650 East Parkway South, Memphis, TN 38104, [pong@cbu.edu](mailto:pong@cbu.edu)

Management (Packaging Concentration). The CBU packaging program is one of the following seventeen packaging schools listed on the website of the Institute of Packaging Professionals ([www.IoPP.org](http://www.IoPP.org)):

- American University of Beirut (Beirut, Lebanon)
- California Polytechnic University (San Luis Obispo, California, USA)
- Christian Brothers University (Memphis, Tennessee, USA)
- Clemson University (Clemson, South Carolina, USA)
- Drexel College of Technology (Minneapolis, Minnesota, USA)
- Fox Valley Technical College (Appleton, Wisconsin, USA)
- Hennepin Technical College (Brooklyn Park and Eden Prairie, Minnesota, USA)
- Indiana State University (Terre Haute, Indiana, USA)
- Michigan State University (East Lansing, Michigan, USA)
- Missouri University of Science and Technology (Rolla, Missouri, USA)
- Mohawk College (Hamilton, Ontario, Canada)
- Rochester Institute of Technology (Rochester, New York, USA)
- San Jose State University (San Jose, California, USA)
- University of Florida (Gainesville, Florida, USA)
- University of Wisconsin – Stout (Menomonie, Wisconsin, USA)
- Virginia Tech (Blacksburg, Virginia, USA)
- Wisconsin Indianhead Technical College (Shell Lake, Wisconsin, USA)

#### Challenges for Undergraduate Research at Primarily Undergraduate Institutions

Primarily undergraduate institutions face many challenges in developing meaningful undergraduate research, including:

- Expensive lab equipment is needed in many areas of research, especially in engineering and science. Even if equipment is obtained from grants or donations, maintaining it can become difficult.
- The teaching load of faculty members is usually high. Thus, they have no time for meaningful research or even to keep up with the current state of subject areas.
- Promotion and tenure considerations are often based on teaching performance. Thus, there is no incentive for research and development effort.
- Financial support for research effort is usually insufficient. Competing for external funding has often proven to be difficult.
- Lack of research vision from administrators has contributed significantly to lack of research at these institutions.
- Lack of research interest from the faculty is another factor. Some faculty members have the view that they are there just to teach.
- It is hard to find research mentors.

To develop a meaningful undergraduate research program in engineering and science, the following key success factors must be met:

- State-of-the-art and well-maintained lab equipment
- Current knowledge about subject areas
- Sufficient funding
- Highly motivated group of faculty members
- University policy that encourages entrepreneurship and innovation

The next sections describe how CBU's undergraduate research in health care packaging has developed over the last few years, during which these success factors were built one by one.

## CEU Packaging Lab: The First Success Factor

From 2003 to 2005, CEU acquired many pieces of state-of-the-art packaging equipment through a \$3M grant from the FedEx Foundation of Memphis as part of its engineering lab renovation project [2]. Some of the packaging-related equipment is shown in Figure 1.



Figure 1. Packaging Related Equipment at CEU Packaging Lab

Top Row (L - R): Drop Tester, Vibration Table, Shock Machine

Middle Row (L - R): Climate Chamber, Temperature/Humidity Chamber, Curing Table

Bottom Row (L - R): Thermoformer, Rapid Prototyping Machine, Injection Molding Machine

Note: Thermoformer was donated by FedEx Foundation. Other pieces were purchased from the FedEx Center

For education purposes, lab equipment can be used for many years without costly calibration. However, well-maintained equipment is needed for R&D work. In 2009, the CEU packaging lab became a commercial lab certified by the International Safe Transit Association (ISTA, [www.ista.org](http://www.ista.org)). It is currently one of seven such certified packaging labs and the only one in an academic setting within the tri-state area of Tennessee, Arkansas, and Mississippi. All seven certified labs are located in Tennessee:

- Christian Brothers University (Memphis, Tennessee, USA)
- FedEx Corporation (Memphis, Tennessee, USA)
- Global Testing Laboratories, LLC (Knoxville, Tennessee, USA)
- Medtronic (Memphis, Tennessee, USA)
- Ouel Manufacturing (Cookeville, Tennessee, USA)
- Sonoco Products Company (Nashville, Tennessee, USA)
- Iriad Packaging (Bristol, Tennessee, USA)

During its first year of certification, the CEU lab generated less than \$1,000 of gross revenue. However, during its second year the gross revenue went up to almost \$13,000. During the current year (3<sup>rd</sup> year of certification), almost \$9,000 of gross revenue was generated during the first three months as the lab customer base expanded. At this rate,

the gross revenue for the current cycle will be \$34,000. Forty percent of the gross revenue is used for equipment maintenance. Even though the revenue is still considered small, the trend shown in Fig 2 is very promising.

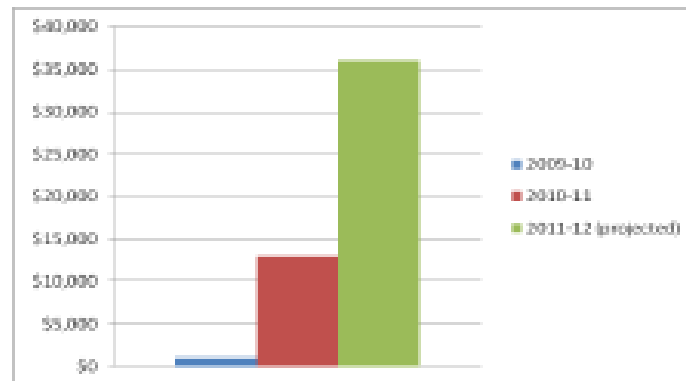


Figure 2. Certified Packaging Lab Gross Revenue

So far undergraduate student have not been involved with commercial package testing due to the desire of customers to complete tests as soon as possible. Scheduling students to work on test projects would result in delays. Furthermore, these tests are not R&D projects and follow certain test procedures outlined by ISTA.

Even so, undergraduate student have benefited indirectly from the packaging lab's commercial revenue. The net revenue provides funds for equipment maintenance and calibration, which is essential for R&D projects that do involve undergraduate students. About \$5K has already been spent this cycle on maintaining/calibrating the drop tester, vibration table, altitude chamber, temperature/humidity chamber, compression table, and cutting table. The drop tester, vibration table, and compression table are used on a regular basis for commercial testing. They are calibrated/maintained on a yearly basis. Other pieces are maintained/calibrated on a two year or three-year cycle.

#### Healthcare Packaging Consortium: The Second Success Factor

The Healthcare Packaging Consortium [5] was established at CBU on June 1, 2010, with seven founding member companies: Evergreen Packaging, FedEx, Medtronic, March Consumer Care, Plastic Ingenuity, Smith & Nephew, and Wright Medical. Its mission is to advance knowledge in healthcare packaging through education and research.

At the beginning of the consortium year, consortium representatives meet to discuss R&D projects to be executed by CBU. They provide some guidance, needed materials, and equipment not available on campus. Some CBU packaging students work on these projects as their required packaging project while some are hired at \$12.50/hour if they do not get academic credit for their work. There are three groups of packaging students who participate in consortium projects:

- B.S. in Engineering Management with Packaging Concentration
- B.S. in other engineering disciplines with Packaging Engineering Certificate (Mostly from B.S. in Chemical Engineering and B.S. in Mechanical Engineering)
- B.S. in other engineering disciplines with Packaging Minor (This minor will become effective next academic year. Currently, one civil engineering major has applied for the minor.)

Consortium consortium R&D projects include:

- Peel Testing Analysis (Sponsored by Smith & Nephew): There are three peel testing techniques within ASTM F88. Often suppliers, contract packagers, and OEM's do not communicate the specific techniques and therefore are not speaking the same language when setting acceptance criteria. This project will attempt to determine if there is a formula that can be applied to translate across the peel testing techniques (90 unsupported vs. 180 supported).
- Seal Width Integrity (Sponsored by Miami Consumer Care): General rules of thumb exist for minimum seal widths on thermoformed packages. These rules of thumb are anecdotal and not supported by data. A large study is required to develop water vapor permeation curves as a function of seal widths.
- Correlation between Burst Testing & Peel Testing (Sponsored by Smith & Nephew): There is not a correlation between peel testing and burst testing but there is a common formula that is stated to translate burst test values into 1.0 lbf peel values. This project will evaluate the robustness of this formula across varying size packages.
- Distribution Tote Testing (Sponsored by Miami Consumer Care): Products in "big box" retailers (Wal-Mart, Target, etc.) and large drug chains (Walgreens, CVS) are typically distributed in large plastic totes. Each tote contains a variety of individual products destined for a specific location in the store. There are no standards in place to perform distribution testing on such configurations; there is a need to standardize these procedures. This project's goals is to develop new ISTA procedures and/or make formal recommendations to retailer distribution centers.
- Impact of 100% Recycled Packaging Content on Performance (Sponsored by FedEx): This project compares the performance of packaging materials such as corrugated material, cushioning peanuts, and various foams when the humidity and temperature are elevated. It also includes low and high temperature & humidity tests to determine the difference in cushioning and compression strength properties between 100% recycled and non-100% recycled packaging materials.
- Performance of Different Pallet Materials and Styles under Diverse Handling and Environmental Conditions (Sponsored by FedEx): There is a great variety of design and material used for pallets that are sourced all over the globe. Pallet materials such as recycled molded pulp, particle board, and corrugated materials have influenced handling in the global supply chain. This project determines if temperature and humidity have an impact on performance of these pallet materials, while comparing them to the typical soft wood GMA pallet used in the United States.

Each consortium project requires undergraduate student involvement. In the first cycle of the consortium (2010-2011), there were two undergraduate students involved with consortium projects. Currently, the number has increased to seven, with more expected in the coming year. Results from these projects have started to appear in various publications [4, 5, 6], and more are in the pipeline. Students are listed in these publications as co-authors.

The Healthcare Packaging Consortium has contributed greatly to undergraduate research in healthcare packaging at Christian Brothers University:

- Consortium member companies are major companies. Their packaging professionals have up-to-date knowledge of the field, and they know the current problems faced by the industry. Thus, the topics sponsored by these companies are timely and relevant.
- The consortium annual membership fee (a total of \$21,000 to reach cycle with the current membership) provides financial support for these projects, including compensation for students who do not work on the project for credit, small equipment acquisition, etc.





- Students are invited to project meetings with the sponsoring company. This gives them an opportunity to network with company representatives, who are typically at the managerial level. This can lead to future job opportunities for students.
- Having student names on publications enhances their resumes.

Five seminars and a one-day conference are arranged for consortium members with no charge each year. These events are also open to the public for a fee. This additional revenue is used primarily for travel expenses to present R&D results. During the first cycle of the consortium, the seminars and conference generated about \$5,000 of net revenue.

#### University Support: The Third Success Factor

Any program or effort would not be possible without support from the university. The author has received a 1/3 time release from his teaching load to coordinate packaging activities, which include the certified lab and consortium. Even though the amount of work could justify a full-time position, the release time demonstrates a positive gesture from the university.

The most significant support is from a special account set aside for packaging operations. Typically, an overhead of 40% from any revenue-generating activities goes to the university's general fund. The university allows the special account for packaging operations to be exempt from this general rule. All packaging revenue stays in the account, which helps make equipment maintenance possible. 100% of net revenue from seminars/conferences, as well as consortium member hip fees, also remains in the account. In this way, the packaging operation at CBU is semi-independent and self-sustaining.

#### Motivated Faculty & Staff: The Fourth Success Factor

Last but not least, a group of motivated faculty and staff is needed. They believe in the opportunity packaging will bring to the university. They believe in the importance of undergraduate research. They are willing to take on challenges by stepping out of their comfort zones into a new area. They work with students on consortium projects as senior project and packaging projects. Currently, this group consists of:

- Kay Brown, Ph.D., Professor of Mechanical Engineering with expertise in thermal systems
- Simpson Maleni, Ph.D., P.E., Professor of Civil Engineering with expertise in structural engineering and solid mechanics
- Robert Meitz, Mechanical Lab Technician
- Asit Kay, Ph.D., Professor of Chemical Engineering with expertise in polymeric materials
- Henry Rhodes, Electronics/Computer Lab Technician
- Larry Rutledge, retired packaging manager from Fed Ex and currently in charge of ISIA commercial packaging at CBU
- Paul Shinn, Ph.D., Professor of Mechanical Engineering with expertise in dynamics, manufacturing and solid mechanics

#### Conclusions

To have a successful and meaningful undergraduate research program, many success factors must be met. It is very important for a primarily teaching institution to select a niche area, such as packaging for CBU. Industry connections are also essential since they can provide support in terms of how to solve timely real-world problems, and financial resources. In CBU's case, the Healthcare Packaging Consortium has successfully drawn seven major companies together. Revenue-generating activities are critical. Grants are fine but they are usually for a limited duration; a continuous revenue stream like the CBU certified packaging lab is needed. Finally, university support

and a motivated group of people are crucial. Without any of these components, it will be very hard to develop a meaningful and successful undergraduate research program.

#### References:

- [1] S. Malesni, A. Kay, Y. Zhou, J. Ventura, P. Shiro, and J. Davilla, "Undergraduate Packaging Programs at CBU," *Proceedings of the 2009 ASSE Southeast Section Conference*, Marietta, GA, April 5-7, 2009.
- [2] Sinpong Malesni, Randal Price, Yew Sheng Shiro, Asit Kay, Eugene McGinnis, Ali Pourbakhshi, K. Madhusan, Joseph Londino, and John Ventura, "CBU Engineering Lab Facility," *Proceedings of the 6th ASEC 2009 Conference*, May 2009.
- [3] S. Malesni, A. Kay, and L. Kuffedge, "Healthcare Packaging Consortium," *Proceedings of the 6th ASEC 2011 Conference*, Memphis, Tennessee, May 3, 2011.
- [4] Larry Kuffedge, Sinpong Malesni, and Anthony Lawrence, "Distribution Tote Testing," *Proceedings of the International Transport Packaging Forum*, Orlando, Florida, April 18-21, 2011.
- [5] Sinpong Malesni, Paul Shiro, Anthony Lawrence, Larry Kuffedge, and Robert Meats, "Preliminary Study of Plastic Tote Drop Impact," *Proceedings of the 6th ASEC 2011 Conference*, Memphis, Tennessee, May 3, 2011.
- [6] Sinpong Malesni, Robert Meats, John Archer, Paul Shiro, Kay Brown, and Larry Kuffedge, "Plastic Tote Drop Impact Study," *Under review for publication in a journal.*

#### Author:

Sinpong Malesni, Ph.D., P.E., is a Professor of Civil Engineering at Christian Brothers University, where he also serves as Packaging Activities & Healthcare Packaging Consortium Coordinator. He obtained his Ph.D. from Texas A&M University and is a registered professional engineer in Tennessee. Dr. Malesni was instrumental to the establishment of the packaging engineering program at CBU during his term as engineering dean from 1999-2005. His background includes construction management, structural engineering, solid mechanics, materials testing, artificial intelligence, and optimization. He is a member of ASPE, IAPPI, and NSPE. He can be reached at [psm@cbu.edu](mailto:psm@cbu.edu).

**Introducing Sae Baja in a Sophomore Mechanics and  
Machines Course**

Wael Mokhtar  
Grand Valley State University, Grand Rapids, MI

Wael Mokhtar

Assistant professor of Mechanical Engineering. Ph.D. in Aerospace Engineering and MS and BS in Mechanical Engineering. Areas of interest include: Thermo-Fluid, Mechanical Engineering Design, Capstone projects and Computational Fluid Dynamics (CFD).

# Introducing SAE Baja in a Sophomore Mechanics and Machines Course

## Abstract

A design project was introduced in a sophomore Mechanics and Machines course. This course was re-modeled by integrating machine elements, basic Mechanics of Material concepts and classical Statics topics. The design project serves as one of the teaching tools that support this integration. In the project, the students were asked to re-design an off-road vehicle for SAE Baja competition. One of the advantages of using SAE Baja was the detailed engineering and safety requirements of the competition. In addition to that, a vehicle was designed and built in the previous year by the school team, which provides an excellent information source for the students during the design process. Another objective from using SAE Baja was to introduce the students to one of the professional organizations and help in activating the local student chapter. The instructor presented the project with a list of technical constraints that served as a starting point. The students have to work in teams and collect more information for the SAE rules and by taking measurements from the vehicle. The project was limited to modifications in the drive train and the suspension system to meet a specified design challenge. The details of the project requirements, and objectives are discussed with samples from the students' work.

## Introduction

Design is one of the core engineering skills. Most of the Engineering Schools use capstone projects and senior level course projects to introduce these skills. Recently, small size design projects started to be used as teaching tools to introduce design skills earlier in the engineering programs. A secondary objective of this early introduction was to have 'real life' application for the theoretical topics of the course. In the freshman year, Mokhtar<sup>1</sup> developed a design course where a team of freshman students re-designed and built an off road vehicle for the SAE competition. The team worked for nearly two semesters where they spent the first semester in design and the second semester was for building. The team was successful to complete the vehicle and compete in the SAE race. All the design was done on CAD which is the only design skill that students have at this level. The feedback from the students was positive. In a sophomore Mechanics and Machine course, Chaphalkar et al.<sup>2</sup> and Mokhtar<sup>3</sup> introduced reverse engineering and open-ended design project to introduce Engineering Problem Solving (EPS) and design skills. In the reverse engineering, the students were asked to reverse engineer a mountain bicycle. The project included technical and cost constraints. In the open-ended project the students were asked to design an overhead mobile crane. With the experience of the first project, the students performed even better in this second project. The challenge also included both technical and budget constraints. Both projects showed success.

Projects, as a teaching tool, were used by Duesing et al.<sup>4</sup> in a freshman CAD course. The students were asked to complete a series of projects where each project focused on a certain tool in the CAD package. Mokhtar<sup>5</sup> used a similar Project-Based-Learning (BPL) in teaching a CFD undergraduate course.

For a Heat Transfer course, Newell et al. <sup>6</sup> and Fleischmann et al. <sup>7</sup> used design projects to support the material of the course for upper level engineering students. Leifer <sup>8</sup> also used projects

in junior level Kinematics and Dynamics courses. Crone <sup>9</sup> used projects in three courses in the Mechanics sequence. Mokhtar et al. <sup>10</sup> presented several approaches of using projects in a Machine Design course. In Thermo-Fluid, Mokhtar et al.<sup>11</sup> discussed the integration of design projects in several level of the engineering program. Mokhtar <sup>12</sup> and Hadim <sup>13</sup> expanded the using of Project-Based-Learning (PBL) in several levels of the engineering program starting from the freshman year to the completion of the capstone senior project.

## **Present approach**

In the present approach, a design project was assigned to the students at the end of a sophomore Mechanics and Machines course. The project was to redesign and address a list of technical concerns in a Mini Baja vehicle and to meet the SAE competition requirements. The main objective of the project was to provide the student with a real application for the topics covered in the course and challenge their skills beyond the course limits. Working in teams with a team captain was among the tools that were used to develop team work skills. Engineering problem solving (EPS) was the main tool that the students used to address the technical concerns in the vehicle. The vehicle was built by the Baja team in the previous year. The technical concerns were some of the defects that team noticed during the SAE race.

An over view of the SAE Mini Baja competition, is presented in the following section. The details of the project and samples from the students' work are discussed. Finally further discussion and conclusions are presented.

## **SAE Mini Baja competition**

Mini Baja is one the design competition that SAE (Society of Automotive Engineers) organize every year. Each team designs and builds an off-road vehicle to meet a set of rules. All teams are given the same engine and the challenge is to design a light strong car that can survive and sequence of testing during the race. Before the race each team has to submit a design and budget report. In the competition day, all vehicles have to pass a detailed inspection. The points of the race include several events such as, acceleration, braking, maneuverability, and fours hours of endurance race. Figure 1 shows three of the cars during the endurance race.



Figure 1: A photo of the Mini Baja vehicles during one of the SAE competitions

Mini-Baja is a good engineering project where the students design and build a product with realistic constraints. It is usually used as a capstone senior project by many engineering schools. It was successfully used before as a project for freshman and sophomore course, Mokhtar <sup>1,12</sup>

### Project overview

Figure 2 shows the vehicle that was built by the team during the previous year. The students was asked to re-design several sub-systems of the vehicle. Below is the list that was given to the students:

- **Speed reducing train:**  
Currently, the speed reduction train includes a CVT and a set of timing belts. Your task is to first evaluate the current system and then develop improvements for better efficiency and reliability. Train devising method has to be used for this part of the project. The final design should include all specifications and stress analysis of the components used such as shafts, bearings, keys, belts, chains, gears, lubrication system, etc.
- **Front and rear suspension:**  
The Baja team decided last year to use independent suspension system (double A-arms). It is required to evaluate the current design, perform loads and stress analysis of the components and develop improvements for better vehicle stability.
- **Steering system:**  
It is required to explore and proposed the recommended components to develop a four-wheel steering system.
- **Knuckle stress analysis:**  
The Baja team has designed and manufactured (CNC) a knuckle. During the last year race, the knuckle failed several times. It is required to evaluate the problem and propose a solution.



Figure 2: The Mini Baja vehicle that was built in the previous year.

The design challenge was to minimize the overall weight and meet the required SAE specifications. It was also required that all parts of the project should include expected cost of the components used. The students worked in teams of 5 to 6 students. A final report and presentation was the product of the project.

### Students' samples

In this section, samples from the students' work are discussed. Figure 3 shows some of the photos that one of the teams presented in their report to show some of the defects in the current design. The right hand side photo shows the interference between the upper A-arm and the spring. Each team spent a lot of time in inspecting the current design and identifying the main defects. This phase of the project is "problem definition" which is one of the major skills for practicing engineer.

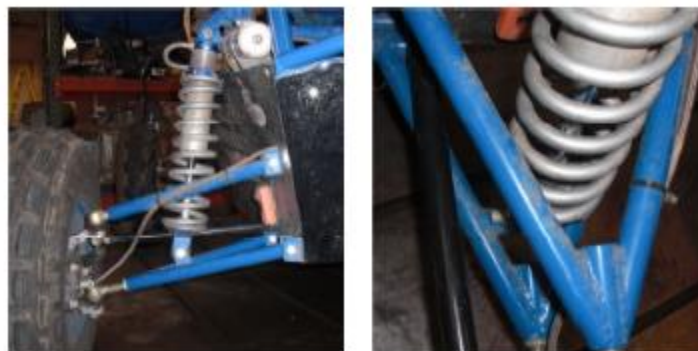


Figure 3: Photos for the front suspension.

After the inspection phase, each team developed a list of concerns that need to be addressed in the new design. Figure 4 shows part of the design process for the front suspension. The figure shows the performance and the new dimensions of the A-arms. Further force analysis was performed on the new design, Figure 5.

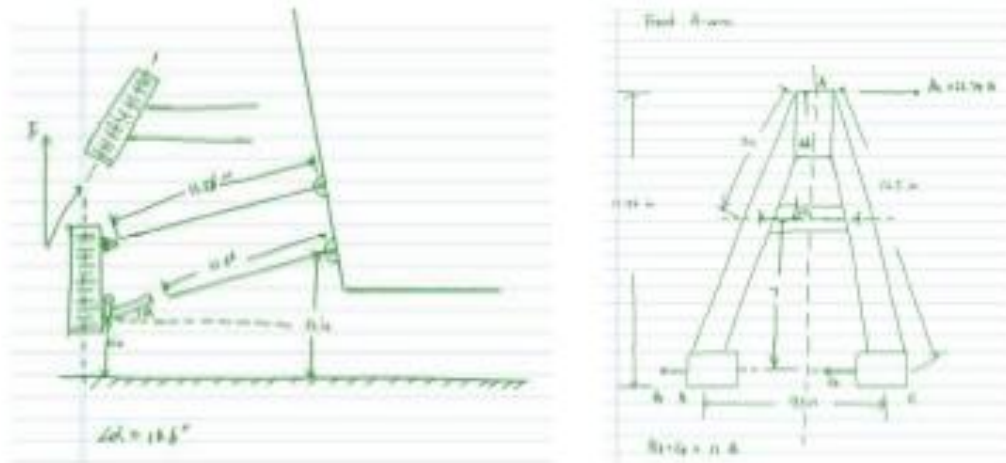


Figure 4 Sketches for the re-designed front suspension.

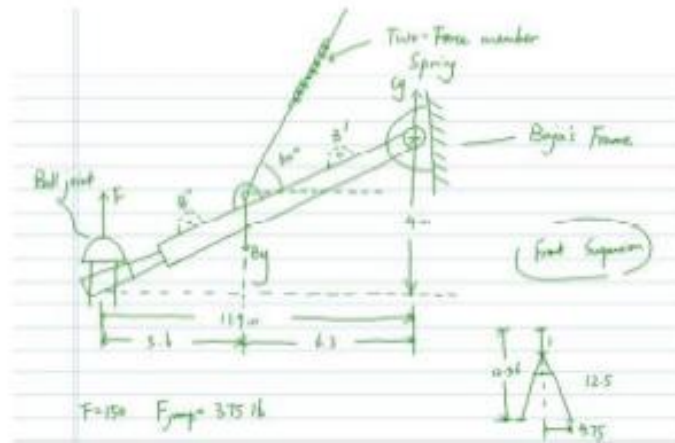


Figure 5: Free Body Diagram (FBD) for the new front suspension.

Figure 6 shows the broken knuckle. This part failed several times during the SAE race. The weld near to the left hand side was done during the race. This is another challenge where loading of the knuckle includes dynamic forces which were beyond the limits of the course. The students had to learn the dynamic loading and added its effect to the force analysis. Figure 7 shows the force analysis. One of the students in this team got more interested in this part of the project and performed a Finite Element Analysis (FEA), Figure 8. FEA is a senior level topic and this student put a lot of time to learn it on his own and performed a reasonable analyses to evaluate the problem.





Figure 6: A photo of the broken front knuckle.

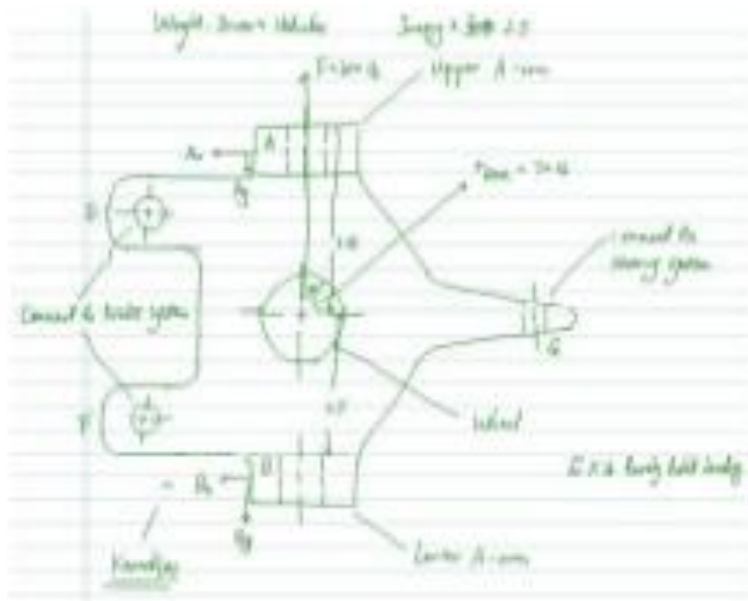


Figure 7: Free Body Diagram (FBD) for the front knuckle.

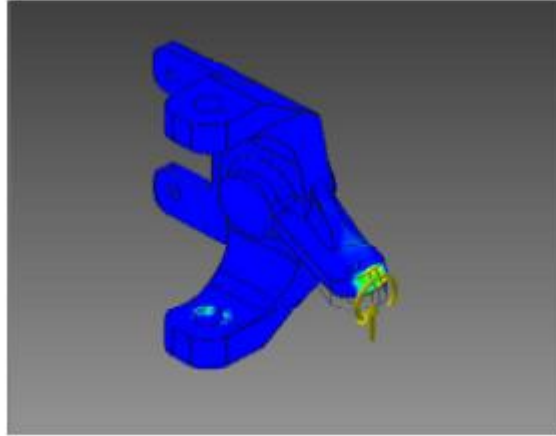


Figure 8: Finite Element Analysis (FEA) for the front knuckle.

Another task for the project was to explore the use of an alternative gear train instead of the CVT. This topic is a new part of the course where the students learn the basics of gears and use simple design software to select the suitable gear. Figure 9 shows the multi-stage gearbox the students selected for the gear train. A 3D CAD view is presented in Figure 10. Based on the limited area inside the car the students decided to use helical gear. The course was limited to spur gear. This team expanded their knowledge to learn how to select helical gears.

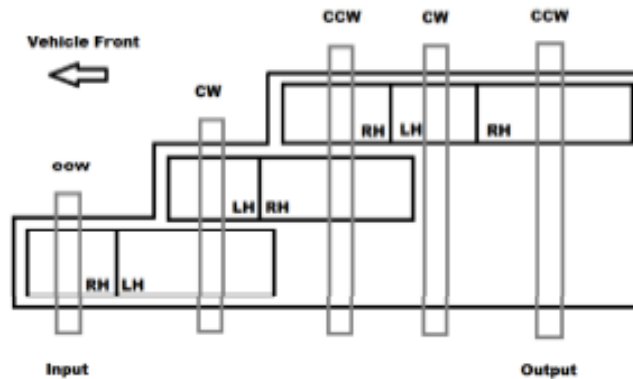


Figure 9: Layout of the designed gear train

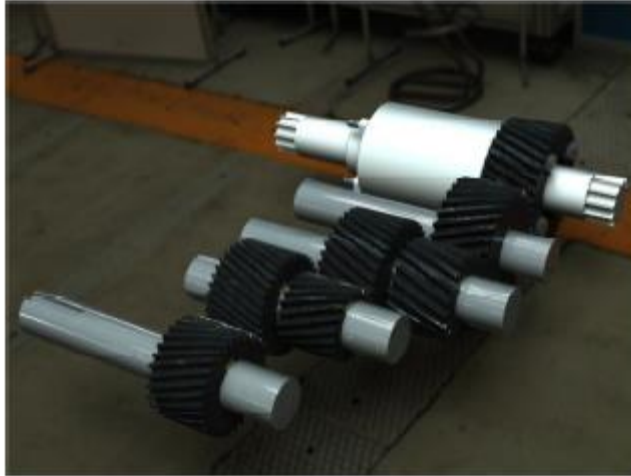


Figure 10: 3D CAD view of the designed gear train.

### **Further discussion**

The main objective of the project was to get the students to apply the knowledge they learn in the course to solve a real engineering problem. The process started with problem definition where team formulated the problem in hand. The full analysis of the current design was the first step in the solution. The teams then proposed solutions for each problem and supported their discussion with calculations.

One of the major benefits of this project was that the students learned a lot of skills beyond the course to complete some of the tasks. This is a very important skill for a professional engineer (life-long learning). Other tasks needed a direct application for the topics covered in the course. This part increased the students' confidence in the subject. Team work was another benefit of the project where the students worked as sub-teams and integrated their work to complete the project. The author used this project before in several courses, being automotive related makes it close to the students.

Another objective of the project was to increase the student interest to join the SAE chapter. Toward the end of the project, several students approached the author to join the team.

### **Conclusions**

SAE Min Baja was used as a re-design project in a Mechanics and Machines course. The students were introduced to several engineering problem solving (EPS) tools. The project showed success and many of the students went beyond the required tasks and learned advanced topics to solve some of the problems.

The project was a design only with no building. It offered a good semi-open-ended problem for a sophomore course. It helped to increase the students' interest in the subject and teach them further skills. The size of the project and the requirements were set to match the time available of the course as a supporting tool.

The author used this project for several courses and with right choice of the requirements, it showed success.

## References

1. Mokhtar, W., "Introducing a Two-Semesters Research Course in the Freshman Year", 2009 ASEE Annual Conference, ASEE no. AC 2009-2416, June 14 - 17, 2009.
2. Chaphalkar, P., Mokhtar, W. and Pawloski, J., "Using Guided Project and Reverse Engineering to Develop Critical Thinking", 2010 ASEE North Central Sectional Conference, Paper no. 130, Pittsburgh, PA, March 26-27, 2010.
3. Mokhtar, W., "Design Experience in a Sophomore Mechanics and Machines Course", ASME 2011 International Mechanical Engineering Congress & Exposition, Paper no: IMECE2011-62736, November 11-17, 2011.
4. Duesing, P. and Mokhtar, W., "Active Discovery and Engineering Problem Solving (EPS) Techniques –An Effective Approach to Teach a Freshman Level CAD Course", ASEE North Central Section Conference April 3-4, 2009.
5. Mokhtar, W., "Project-Based Learning (PBL) – An Effective Tool to Teach an Undergraduate CFD Course", 2011 ASEE Annual Conference, ASEE no. 973, Vancouver, BC, Canada, June 26-29, 2011
6. Newell, T. and Shedd, T., "A team-oriented, project-based approach for undergraduate heat transfer instruction", 2001 ASEE Annual Conference, Albuquerque, 2001.
7. Fleischmann, S., Sozen, M., and Mokhtar, W., "A Green Heat Transfer Design Project to Introduce Globalization and Society Awareness", ASME 2010 International Mechanical Engineering Congress & Exposition, Paper no: IMECE2010-38285, November 12-18, 2010.
8. Leifer, J., "An Active Learning Design Project for a Junior-Level Kinematics and Dynamics Class", 32nd ASEE/IEEE Frontiers in Education Conference, Boston, November 2002
9. Crone, W., "Using an Advanced Mechanics of Materials Design Project to Enhance Learning in an Introductory Mechanics of Materials Course", The 2002 American Society for Engineering Education Annual Conference & Exposition, ASEE, no 2268, 2002.
10. Mokhtar W. and Duesing, P., "Using Research and Applied Projects to Enhance Learning in Mechanical Engineering Design Courses", The International Journal of Learning, Common Ground Publisher, vol. 15, no. 8, pp: 265-276, November 2008.
11. Mokhtar, W., and Carroll, M., "ABET Accreditation - Realization in Thermo/Fluid Courses", AIAA 47th Aerospace Science Meeting and Exhibit, AIAA paper no. AIAA-2009-570, January 2009.
12. Mokhtar, W., Duesing, P., and Hildebrand, R., "Integration of the Project-Based Learning (PBL) into the Mechanical Engineering Programs", The International Journal of Learning, Common Ground Publisher, vol. 15, no. 8, pp: 265-276, November 2008.
13. Hadim, H., and Esche, S., "Enhancing the Engineering Curriculum Through Project-Based Learning", 32nd ASEE/IEEE Frontiers in Education Conference, Boston, November 2002.

**CGS Brain Busters: A K-16 Dynamic Educational Boxing Game**

Rasha Morsi, PhD  
Norfolk State University  
555, Park Avenue  
(757) 823-0023  
[rmorsi@nsu.edu](mailto:rmorsi@nsu.edu)

Terin Reed  
Norfolk State University  
555, Park Avenue  
[terinreed@yahoo.com](mailto:terinreed@yahoo.com)

## CGS Brain Busters: A K-16 Dynamic Educational Boxing Game

### Abstract

This paper presents the design and development of an educational boxing game that provides the user with the ability to edit the educational game content with minimal programming experience. The overall objective is to design and implement an easy-to-use game interface in which educational elements can be incorporated to help improve the player's core knowledge in any critical subject area. The boxing game is geared towards upper level high school to beginning college students; however, the design can accommodate any level of content from pre K – 16.

### Introduction

In order to master any subject area, a solid grasp of the fundamental concepts of that area is required. It is imperative to present material to the student in a way that allows him/her to assimilate the information with as little difficulty as possible. 'Identification' and 'Association' (I&A) are simple ways to learn core concepts in a rapid, efficient manner. Used correctly, I&A allow the ability to develop tools that visually engage the player as he/she learns. I&A can be used in subject areas ranging from basic shape identification to complex symbol association. By presenting 'Identification' and 'Association' concepts in a fun user friendly environment, students can be more engaged and minimize any feelings of frustration that would be encountered while practicing fundamental skills associated with any subject area. This paper will present *CGS Brain Busters* (an educational boxing game). *CGS Brain Busters* is intended for high school to college level educational content; however, it can be used for content ranging from pre K – 16.

### Background

Video games are generally thought of as leisure activities used to entertain. They use fancy graphics and sounds to keep the game players interested. Video games do have another side, however; they sharpen reflexes and promote immediate decision making. The hours people spend playing video games can also increase skills such as logical and analytical skills as well as problem solving without the player even knowing that he/she is improving those skills.

### Educational games

In order to develop a successful game environment, it must be determined which types of Flash based-games are currently available. There are many different types of educational web-based Flash games available for download on sites such as Prongo<sup>1</sup>, Class tools<sup>2</sup>, and the Problem Site<sup>3</sup>

to name a very few. These games, while presenting basic educational content, lack the curriculum based content presented in a fun unique environment.

Prongo<sup>1</sup> (see Figure 1) contains many games, e-cards, jokes, and brain teasers that have an educational focus. These games are designed for students between the ages of 3 and 12 and cover subject areas such as math and language. One of the more interesting games is *Wally The Stock Ticker*<sup>1</sup> which allows the student to choose a company and view that company's stock symbol, current price, change of price from yesterday, date of last trade, etc. As the student views the information an explanation appears that describes what the student is viewing. This game serves more as an informational tool than a game but the information is laid out in such a way that the student can understand what he/she is viewing.



Figure 1 Prongo stock ticker game<sup>1</sup>

The Lemon Larry game<sup>1</sup> (see Figure 2), is a multiplication game developed using Adobe Flash. Once the player enters and answer it provides feedback on whether it is correct or not. However, it provides the correct answer if the player makes a mistake.

Classtools.net<sup>2</sup> (see Figure 3), "allows you to create free educational games, activities and diagrams in a Flash! Host them on your own blog, website or intranet! No signup, no passwords, no charge!"<sup>2</sup>. Classtools.net allows the user access to template files that can have content entered in them. Once the content is in place, the file can be saved on the user's computer or placed on the Classtools.net server so the template can be embedded in

a wiki, website, or blog. These templates consist of text boxes where the user can add information that is then used in a game. The games range from matching games and flash card games to space invader type games. These games use the definitions and words entered by the user to teach students the content area specified by the teacher.

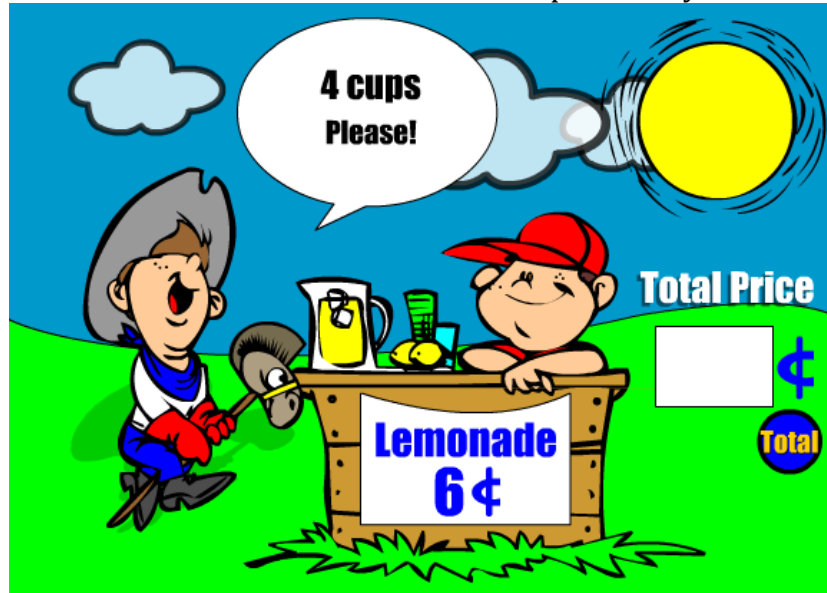


Figure 2 The Lemonade Larry game <sup>1</sup>

The Problem Site<sup>3</sup> is a collection of educational games and puzzles to help students engage in learning in interesting ways. The games on this site range from math games to word games.

**ClassTools.net** Arcade Game / Quiz / Flashcard generator!

[TITLE OF QUIZ GOES HERE]

1. Type the title of your quiz in the box above.
2. Input your questions & answers in the box below (or paste from a word processor).
3. Separate each question from its answer with an asterisk: **question\*answer**
4. Start each question on a fresh line.

What is two plus two?\*Four  
 What is the capital city of England?\*London  
 Who painted the Mona Lisa?\*Da Vinci  
 Who sang "Jailhouse Rock"?\*Elvis Presley  
 When was the Battle of Hastings?\*1066  
 When did World War Two end?\*1945  
 Where was Jonh Lennon killed?\*New York  
 Where are the pyramids?\*Egypt  
 What is the best website in the world?\*classtools.net  
 Who is the most modest web designer in the world?\*Russel Tarr  
 [etc!]

Password to stop players editing this screen (leave blank if not required)

Game to direct players to automatically (only works if password set):

[Sample Files .zip](#) **ClassTools.net**



Figure 3 Arcade game generator template<sup>2</sup>

In summary, a review of current K-16 educational Flash-based games on the web found none that mixed unique genres, in particular the boxing game genre, with educational elements in a dynamic content generation setting. This creates an interesting and exciting new area for educational Flash-based games to expand into. The boxing game genre can effectively immerse the game player in the game environment and the story line by allowing the user to actively participate in the game.

### CGS Brain Busters

Figures 4 and 5 show the game's main screen and initial menu, respectively. On the initial menu screen (see Figure 5), the player is presented with a list of nine possible opponents. Each opponent has a specific educational proficiency. These proficiencies range from mathematics, to engineering, to languages. Due to the dynamic nature with which the game pulls the educational content, the content can be any subject or topic where the educational aspect is based on 'Identification' and 'Association' (I&A). The current version of the game contains the following educational elements:

- Analog circuit components
- Analog circuit analysis terms
- Digital logic elements
- Electronics lab components
- Periodic table of elements
- Chinese numbers
- Scientific prefixes
- Geometry terms
- Greek alphabet



Figure 4 CGS Brain Busters main screen

Another version of the game, designed for elementary school students, includes content from poetry and geometrical shapes.

### CGS game characters

The characters (see Figure 5) for the game are customizable. The characters are designed to be images and animations of real people to provide the feel of realism in the game. This also allows the game to be personalized - the game is designed to allow the teacher to customize the characters in the game. This allows it to be more fun for the student.



Figure 5 Main game menu (characters)

### CGS gameplay

The gameplay is intended to be fun and carefree. The boxing motions are developed intentionally to be more humorous than real boxing movements to not be promoting violence. The player is presented with a randomly selected educational element for which the player will have to select the response from a list of answers provided. Depending on whether or not the player selects the correct answer, the player will receive a hit from the opponent or gain a hit point. Once enough hit points are accumulated, the player can then attack the opponent by using these hit points (see Figure 6). After exhausting the hit points, the player must identify more educational elements to continue to accrue points and box. When the player's health points reach zero, the player loses the round and is prompted to continue or quit. If the opponent's health points reach zero before the player's does, then the player progresses to the next opponent. In order to win, the player must defeat six opponents. If the player wins, a congratulatory message is displayed and the game is reset.

After every round, the player is given feedback on his/her progress which can be recorded for further evaluation. The information displayed includes numbers of correct answers, incorrect answers, and the average time taken per correct answer.

A	B	F
0	0	1
0	1	0
1	1	1

Not Enough Hit Points

Hit Points: 7

Time 0:34

Special Moves Remaining: 1

Blocks Remaining: 7

AND Gate	XNOR Gate	AND Truth Table
OR Gate	Truth Table	OR Truth Table
NOT Gate	S.O.P.	XOR Truth Table
NAND Gate	P.O.S.	Minterm Expr.
NOR Gate	Maxterm Expr.	
XOR Gate	XNOR Truth Table	

Increase your hitpoints by correctly identifying the element. Attack with the <LEFT>, <RIGHT>, and <UP> keys. 2 Hit Points to Punch, 6 Hit Points to Kick, 8 Hit Points to perform a Special Move. Block with the <SPACEBAR>. YOU CAN ONLY BLOCK AFTER BEING ATTACKED!

**Figure 6 CGS gameplay**

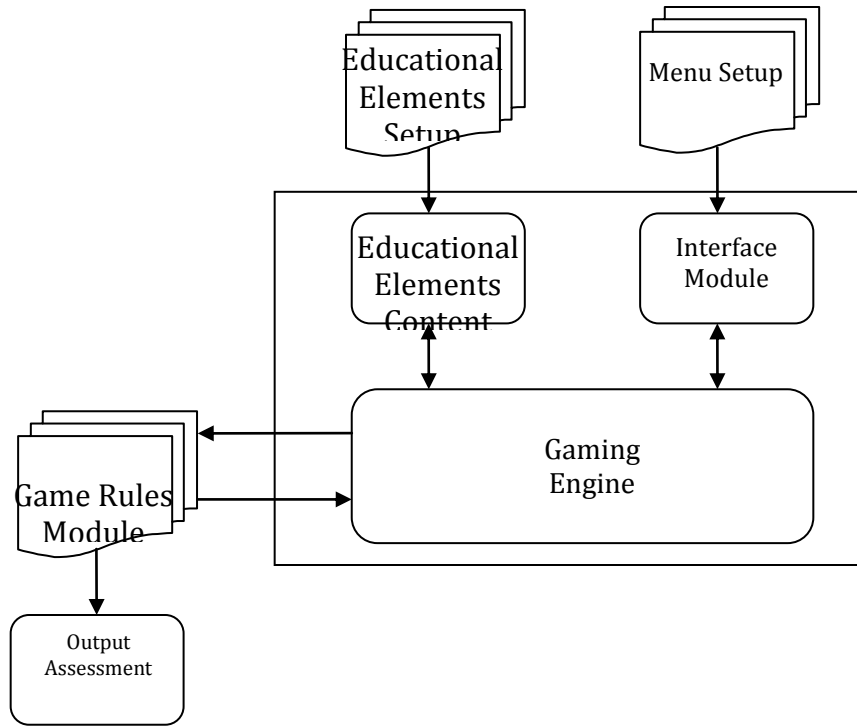
## Game framework

The goal of the *CGS Boxing Game Model* (see Figure 7) is to provide a framework for an educational boxing game where the content developer, with little to no programming experience, can edit or add content using a Flash template file. The framework requires a Flash template file with the graphics appropriately linked and the code files that actually build the application. The game design model allows for dynamic content without access to game play source code. *CGS Brain Busters* is designed to be used by upper level high school to beginning college students although, with appropriate educational content, it can be used for K – 16 education. This game is designed to allow students to assimilate content and be tested on their knowledge and given feedback on their progress. However, correct responses are not provided. This allows the student to work on identifying where s/he went wrong rather be told what the correct answer is.

## Game modules

### Educational elements unit

The primary function of the *Educational Elements* unit of the *CGS Boxing Game Model* (which includes both the setup and content modules) is to control the educational elements and user interface including placement, content, and functionality. This unit includes the *Educational Elements Setup* file (which is an external .as file) and the *Educational Elements Content* itself and is the backbone of the game design model that allows for dynamic content and random content item selection.



**Figure 7 CGS game framework**

The educational elements (see Figure 8) are entered by the content developer and are randomly selected by the application for the player to identify. The framework is designed to accept 18 elements per character. These elements can include letters, numbers, pictures, small movie clips, or any module format allowed by Adobe Flash.

#### Menu setup and interface modules

The *menu setup module* contains the coordinates for the placement of all the elements which appear on the different areas of display on the game user interface. This file also contains the names of each different component that is used to build each game scene. The menu setup file does not affect the educational elements and therefore is not necessary for the framework to run. The contents of this file serve as a way to immerse the player in the game in order to enhance the educational impact of the game. The *Interface Module* assigns functionality to all the components of a game scene. This includes the playing of sounds, and allowing for user interactivity with the components used in the different game scenes.

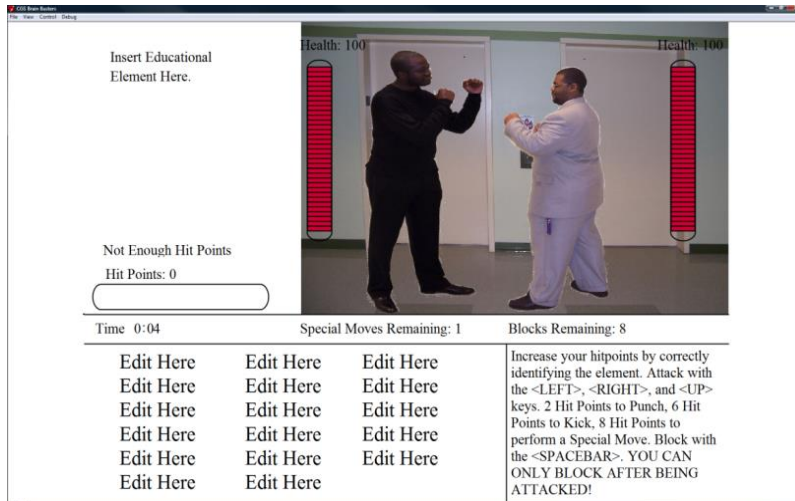


Figure 8 Educational elements screen

## Gaming engine

The gaming engine is where the components from the *Menu Setup*, *Interface Module*, and *Educational Elements* portions of the game model are used together to allow for interactivity with the player. For the game interface, the gaming engine attaches the actual graphics from the Flash library to the ActionScript code contained in the external .as files associated with the *Educational Elements Setup* and *Menu Setup* modules. The components contained in the gaming engine include graphics and sounds.

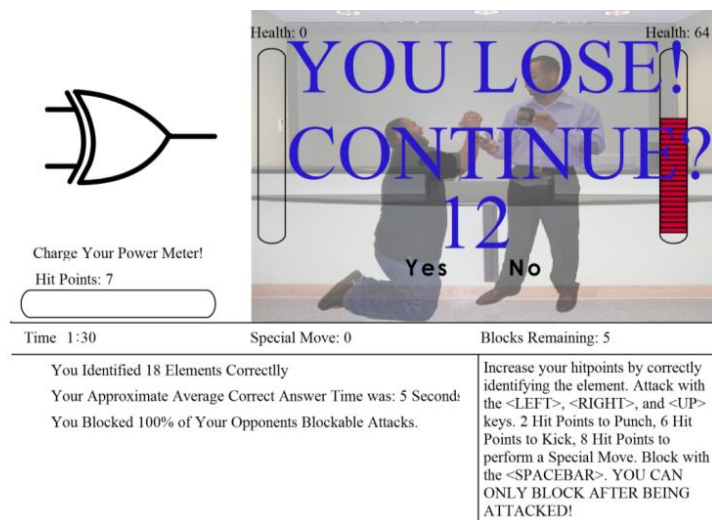


Figure 9 Output assessment screen

## Game rules

The *Game Rules Module* contains all the game play rules for the players and opponents. This module defines elements such as user controls, opponent artificial intelligence, and winning and losing.

#### Output assessment

The *Output Assessment* portion (see Figure 9) provides the user with immediate feedback on the game progression and statistics that were collected during game play.

## Conclusion

This paper presented an educational boxing game (CGS Brain Busters) which is customizable with respect to players as well as educational content. The game is designed to train students on content which requires ‘Identification’ and ‘Association’ (I&A) which is representative of any core concepts that are expected to be learned in any subject area. Two different versions of the game have been developed so far. CGS Brain Busters is currently at the evaluation phase. Efforts are under way with a local school to pilot the game in the 4<sup>th</sup> and 5<sup>th</sup> grade. The primary author is also initiating an evaluation in Digital Logic Design (a college sophomore level course) in Computer Science and Electrical and Computer Engineering degree programs.

## Acknowledgements

Our thanks go to the CGS graduate and undergraduate students who agreed to be the CGS Brain Busters game characters.

## REFERENCES

- [1] Prongo. *Prongo.com*. [Online] [Cited: September 20, 2011.] <http://www.prongo.com/>.
- [2] Tarr, Russel., Create interactive flash tools/ games for education. *classTools.net*. [Online] [Cited: September 20, 2011.] <http://classtools.net/>.
- [3] The Problem Site: Problem Solving and Educational Games. *The Problem Site*. [Online] [Cited: September 20, 2011.] <http://www.theproblemsite.com/>.
- [4] Embi, Z. C., 2008. The Implementation of Framework for Edutainment: Educational Games Customization Tool. *International Symposium on Information Technology (ITSim 2008)*. Vol 1: 26-28 Aug 2008, 1-5.
- [5] Barendregt, Wolmet and Bekker, Mathilde M., 2004. *Towards a Framework for Design Guidelines for Young Children's Computer Games*. Eindhoven : The Netherlands:Springer.
- [6] Rhodes, Glen. 2006. *Macromedia Flash Professional 8 Game Development*.. Charles River Media Boston, MA .

## **Fabrication and Performance of Inverted Organic Solar Cells**

Tyler J. Perlenfein  
Department of Chemical and Biological Engineering,  
Drexel University,  
Philadelphia, PA

Dr. Jason B. Baxter  
Department of Chemical and Biological Engineering,  
Drexel University,  
Philadelphia, PA

## Fabrication and Performance of Inverted Organic Solar Cells

### Abstract:

The present challenge of the photovoltaics industry is overcoming the large expenses associated with materials and processing. High vacuum and high temperature processing is a major factor affecting the cost of traditional solar cells. Solution-based processing of cheaper semiconductor materials (using spin coating, inkjet printing, screen printing, etc.) at low temperatures is an attractive method of cost reduction. Therefore the photovoltaic properties of the semiconducting polymer poly(3-hexylthiophene) (P3HT) blended with phenyl-C61-butryic acid methyl ester (PCBM) was investigated. Starting with conductive ITO-coated glass substrate, a thin layer of titanium oxide (TiO<sub>x</sub>) was spin coated and annealed. A blend of P3HT and PCBM was then spin coated onto the TiO<sub>x</sub>, forming the active layer. Gold contacts were evaporated to complete the inverted cell structure, which is more stable in air than conventional solar cells. The cells were characterized by taking current versus voltage and current versus wavelength curves, along with light harvesting efficiency data. Baseline quantum efficiencies, fill factors, and power conversion efficiencies were established for these cells. Active layer thickness, annealing times, and annealing temperatures were varied in order to optimize both light harvesting efficiency, short circuit current, and fill factor. A thin electron blocking layer of poly(ethylenedioxythiophene) doped with poly(styrene sulfonic acid) (PEDOT:PSS) was deposited on top of the active layer before electrode evaporation to improve the short circuit current by increasing the selectivity of the contact to holes while blocking electrons. Cell efficiency increased over the first 30 minutes of light exposure and also over several days of exposure to air. The short circuit current of this cell peaked at 8.2 mA/cm<sup>2</sup>. With an open circuit voltage of 535 mV and fill factor of 43.5%, this cell had an efficiency of 1.91%. A light harvesting efficiency peak of 88.8% was obtained for the best-performing cell, but internal quantum efficiencies only 50%, indicating that efficiency is limited either by exciton dissociation or charge collection. Using layers of PEDOT:PSS increased the fill factor and photovoltage, however the desired effect of this layer on short circuit current has not yet been observed. Further work in the area of polymer photovoltaics will hopefully see high enough efficiencies to warrant industrial-scale applications.



## Introduction:

The field of organic photovoltaics (OPVs) is growing very quickly in the scientific community. Between the years of 2002 and 2010, there were 1032 papers published in scientific journals worldwide concerning OPV cells with the P3HT:PCBM bulk heterojunction structure, with growing numbers from years to year.<sup>[1]</sup> This is mostly due to the high potential of these products for large-scale industrial applications. Solution-based processing at low temperature is a key attribute of this field, making it compatible with large-throughput, high yield processes. While OPVs currently show power conversion efficiencies in the 3-6% range, this field of photovoltaics is still young and there are many aspects of OPVs that are not well understood or not fully explored. Studies that focus on reducing bulk and interfacial charge recombination, improving the carrier lifetimes in the bulk, and improving the charge collection characteristics of the cell through nanostructuring various layers all have potential to increase the average efficiency of OPV cells.

The operation of the OPV cell begins in the photoactive layer, which is comprised of semiconducting extended polymer chains blended with fullerenes. An incident photon of correct energy creates an exciton upon absorption, which diffuses through the active layer until either the electron or hole is conducted away or the two recombine. Charge separation happens when the electron-hole pair reaches an interface with a material of differing band energies. Because of the relatively short exciton diffusion lengths in most polymers (~10 nm), it is helpful to lessen the distance that the exciton must travel to reach this interface. Thus, the bulk heterojunction OPV was introduced in which donors and acceptors are intimately blended, creating interpenetrating nanoscale domains of electron and hole conducting materials. The most popular blend to date is P3HT (hole-conducting) and PCBM (electron-conducting).

The OPV cell is traditionally manufactured in the following manner: a layer of PEDOT:PSS is deposited on top of transparent, conducting indium tin oxide (ITO) by many different kinds of solution-based processing techniques. This forms an electron-blocking layer that helps to prevent leakage currents from developing in the counter electron flow direction. The active layer composed of P3HT:PCBM is then deposited on top of the PEDOT:PSS, again through some kind of solution process. Normally, a transparent, thin layer (~1 nm) of lithium fluoride is then deposited on top of the active layer which promotes electron flow and blocks hole transport. Finally, a low work function metal is deposited on top of the TCO to complete the cell. Problems with stability arise in this cell configuration, however. The acidity of the PEDOT:PSS layer tends to corrode the ITO or FTO, reducing charge collection capabilities. Any moisture which permeates the PEDOT:PSS layer tends to form insulating oxides which can greatly increase the series resistance of the cell. Finally, the low work function top electrode (traditionally aluminum) is readily oxidized which also increases the resistance of the cell.

In response to the stability challenges of the traditional OPV cell architecture, researchers have developed a so-called "inverted structure" in which the layer deposition order is reversed, with the lowest work function layers being deposited on top of the ITO substrate first. In this cell scheme, the oxide hole-blocking layer is deposited on the ITO, followed by the active layer. The electron blocking layer (either PEDOT:PSS or a group VB or VIB transition metal oxide) is then deposited. Following this is the deposition of a high work function metal (gold or silver) to complete the cell. This type of cell structure offers much greater air stability than the traditional type, due to a few contributing factors. The PEDOT:PSS is not in direct contact with the ITO, thereby eliminating the corrosion in the ITO layer. Also, the aluminum contact is replaced by a higher work function metal, which takes much longer to form surface oxide layers.

This work focuses on fabrication and characterization of OPV cells using the inverted structure. ITO substrates were coated in either ZnO or TiO<sub>x</sub>, followed by deposition of a P3HT:PCBM layer and gold or silver electrode. Cells were produced with and without the PEDOT:PSS layer between the active layer and metal electrode. An emphasis was made on low-temperature solution processing of each layer (with exception of the metal electrode) in order to be consistent with the requirements of large scale industry.

Cells were characterized by I-V performance, absorbance spectroscopy, chronoamperometry, and scanning electron microscopy. Studies were conducted in order to optimize performance of the OPV cell, including: looking at effects of different oxide layers, changing the thickness of the active layer, effects of the presence of a PEDOT:PSS layer, effect of annealing times, looking at air stability over a period of a few days, and effects of light exposure over a period of up to an hour.

#### Experimental:

ITO coated glass sheets (~120 nm thickness, Colorado Concept Coatings) were first cleaned via sonication in heated acetone, 3% soap solution, then isopropanol. The panels were removed and dried with nitrogen gas before coating. For ZnO layers, the precursor solution was composed of .375 M zinc acetate with equimolar ethanolamine in anhydrous ethanol solvent (Sigma Aldrich). The solution was heated to 60 °C and stirred for 4 hours until it became clear.

Zno layers were prepared via dip coating ITO panels in the precursor solution at a speed of 200 mm/min and relative humidity below 15%. The panels were subsequently transferred to a glove box through which nitrogen gas was flowing. The gas was held at 32% relative humidity. The panels were annealed at 400 °C for 20 min under these conditions.

TiO<sub>x</sub> layers were prepared using a precursor solution composed of 1 wt% titanium isopropoxide (TTIP) in anhydrous 2-propanol (Sigma Aldrich).

TiO<sub>x</sub> layers were spin coated using approximately 200 μL of the precursor solution on ITO panels at 2000 rpm for 30 seconds. The panels were allowed to sit in air for one hour, then annealed at 150 °C for ten minutes to fully hydrolyze the TTIP into TiO<sub>x</sub>.<sup>[2]</sup>

Active layer solution was composed of a 2.4 wt% blend of equal mass parts P3HT (Merck M101) and PCBM (American Dye Source) in chlorobenzene. This solution was heated to 100 °C for approximately 15 seconds to aid in solute dissolution, then removed from the heat and stirred overnight. Immediately prior to use, the solution was sonicated for 10 minutes in a room temperature bath, then loaded into a syringe and strained through a 0.45 μm PVDF syringe filter upon dispensing.

The active layer was deposited onto ZnO or TiO<sub>x</sub> layers by spin coating the P3HT:PCBM solution at 500, 1000, 1500, 2000, and 2500 rpm for 50 seconds. ITO for back contacts was exposed by swabbing strips of the active area with chlorobenzene. The panels were then annealed at 170 °C for times of 1, 5, or 10 minutes.<sup>[3]</sup>

PEDOT:PSS (Clevios P VP AI 4083) was prepared for deposition by mixing with methanol. In undiluted form, the water-based PEDOT:PSS does not wet the surface of the active layer. The addition of 2 volume parts methanol to 1 volume part PEDOT:PSS decreases the surface energy of the drop/active layer interface and allows for better wetting to take place.

PEDOT:PSS was deposited by spin coating at 2000 rpm for 4 minutes. After deposition, a thin strip of ITO was exposed by swabbing with hot water (approximately 80 °C). The panels were then annealed at 90 °C for 30 minutes in order to drive out the resident water in the PEDOT:PSS layer and to improve the contact between this layer and the active layer.<sup>[4]</sup>

Immediately after the panels had cooled to room temperature, masks were applied and the panels were loaded into the thermal evaporator. Gold or silver electrodes were deposited at a rate of 1 Å/s in a vacuum of  $5 \times 10^{-5}$  torr.

After evaporating, data was taken on the cells over a period of a few days. Transient photocurrent behavior was studied by light illumination for up to 30 minutes.

#### Results:

It was found that cells using a ZnO layer as a TCO showed an initial photocurrent of 2.4 mA/cm<sup>2</sup>, which rapidly degraded upon exposure to light by up to 50% over a 30 minutes exposure period. Cells that used TiOx instead of ZnO were found to have initial photocurrents of 0.1 mA/cm<sup>2</sup>, which improved with light exposure over a period of 30 minutes to 4.2 mA/cm<sup>2</sup>. This increase in photocurrent is attributed to free electrons in the TiOx layer filling trap states, allowing other electrons to pass through unhindered. Oxygen scavenged from air during the period of film development is also thought to increase the conductivity of this layer.<sup>[5]</sup> Initial I-V curves for ZnO under light intensity of 100 mW/cm<sup>2</sup> showed Voc of 420 mV, a fill factor of 41.2%, and a power conversion efficiency of 0.5%. TiOx cells, under the same light intensity and after a 30 minute exposure period, showed a Voc of 500 mV, FF of 48.5%, and PCE of 1.03%.

When altering the spin coating speed during deposition of the active layer, it was found that a speed of 500 rpm produced the thickest layers and showed the highest amount of absorbance, which peaked at OD of 0.8. Though still lower speeds would produce thicker layers, a practical limit on the active layer thickness is imposed due to non-uniformities that arise at slower speeds.

The annealing time had a significant impact on the cell performance. The results of this test are shown in Table I.

Annealing Time (min)	Jsc (mA/cm <sup>2</sup> )	Voc (mV)	FF	Eff
1	5.46	470	36.46%	0.93%
5	4.26	500	48.50%	1.03%
10	3.64	530	41.12%	0.79%

Table I. Annealing time study of TiOx-based cells.

It can be seen that the most short circuit current is derived from cells with the smallest P3HT and PCBM domain sizes, as governed by anneal time. This is attributed to the higher internal quantum efficiencies caused by the larger interfacial area in the active layer. The performance of these cells are limited by an inflection point in the I-V curves and low shunt resistance. The highest cell efficiency is observed after annealing for 5 minutes. The fill factor of the cell is increased due to the disappearance of the inflection point after annealing. Longer annealing leads to slightly larger domains, which improves charge transport at the possible expense of charge separation.

PEDOT:PSS was shown to have a relatively small effect on the OPV cells. The results are shown in Table II.

	Jsc (mA/cm <sup>2</sup> )	Voc (mV)	FF	PCE
no PEDOT:PSS	3.71	500	42.10%	0.78%
PEDOT:PSS	4.01	515	38.90%	0.80%

Table II. Effect of PEDOT:PSS Layer.

It can be seen from Table II that the inclusion of a PEDOT:PSS layer did relatively little to increase the attributes of the cell. This seems to contradict current literature and could be due to poor adhesion of the PEDOT:PSS layer on the active layer, causing little or no deposition.

It was shown that the performance of the TiO<sub>x</sub>-based cells improved over both light exposure and a period of aging in air for a few days.

Exposure Time (min)	Jsc (mA/cm <sup>2</sup> )	Voc (mV)	FF	PCE
1	0.61	185	30.50%	0.04%
5	3.26	370	31.20%	0.37%
20	3.4	410	31.60%	0.45%
30	3.4	470	34.60%	0.55%

Table III. Light exposure study with TiO<sub>x</sub> on day 1.

Table III shows the effect of exposing the TiO<sub>x</sub> cells to light. In each study, the light intensity was the same as the testing conditions of 100 mW/cm<sup>2</sup>. As can be seen, the short circuit current reaches a steady-state value at approximately 30 minutes of exposure, and cell performance approaches a maximum value. The data in Table III is taken on the day of cell fabrication. These same cells were tested again after aging for 2 days in air. After another 30 minutes of light exposure, the I-V sweep showed Jsc values around 4.1 mA/cm<sup>2</sup>, Voc of 510 mV, FF of 38.9%, and PCE of 0.8%. This trend of improved cell performance after aging has been demonstrated with multiple batches of OPV cells.

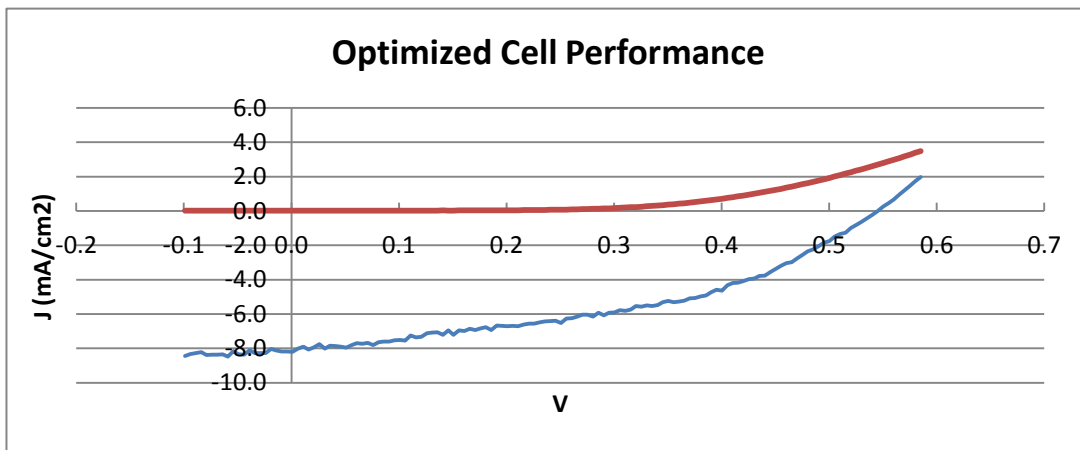


Figure I. Light and dark curves showing optimized cell performance.

The best-performing cells produced after optimization showed a Jsc of 8.2 mA/cm<sup>2</sup>, Voc of 535 mV, FF of 43.5%, and PCE of 1.91%.

Though OPV solar cells are markedly less efficient than others in the industry, notably mono- and polycrystalline silicon, this type of cell shows great promise in its potential to significantly lower the manufacturing and materials cost of the solar industry, and to provide a more flexible product to consumers.

Acknowledgements:

Funding for this project was provided by the Energy Commercialization Institute, Ben Franklin Technology Partners of Southeastern Pennsylvania.

This work would not have been possible without the guidance and support of principle investigator Dr. Jason Baxter. The author would also like to thank Hasti Majidi, Borirak Opananont, Glenn Guglietta, and Siamak Nejati for their generous and helpful advice.

#### References:

- [1] M. Dang, L. Hirsch, G. Wantz, *Adv. Mater.* 2011, 23, 3597–3602.
- [2] J. Kim, K. Allen, S. Oh, S. Lee, M. Toney, Y. Kim, C. Kagan, C. Nuckolls, Y. Loo, *Chem. Mater.*, Vol. 22, No. 20, 2010.
- [3] C. Kim, S. Lee, E. Gomez, J. Kim, Y. Loo, *Appl. Phys. Lett.* 94, 113302, 2009.
- [4] Krebs, *Polymer Photovoltaics: A Practical Approach*. SPIE Press, 2008.
- [5] K. Lee, J. Kim, S. Park, S. Kim, S. Cho, A. Heeger, *Adv. Mater.* 2007, 19, 2445–2449.F.

## **Goddard Electro-Magnetic Antenna Anechoic Chamber**

F. Pinto  
Department of Engineering  
Virginia State University  
Petersburg, VA 23806

E. Sheybani  
Department of Engineering  
Virginia State University  
Petersburg, VA 23806

Singli Garcia-Otero, Ph.D.  
Department of Engineering  
Virginia State University  
Petersburg, VA 23806  
804.524.8989 X 1126  
Fax: 804.524.6732  
[sgarcia-otero@vsu.edu](mailto:sgarcia-otero@vsu.edu)

# Goddard Electro-Magnetic Antenna Anechoic Chamber

F. Pinto, E. Sheybani and S. Garcia-Otero

## Abstract

The Goddard Electro-Magnetic Antenna Anechoic Chamber (GEMAC) is a world-class facility for measuring radiation patterns of antennas and other microwave devices and instruments.. Anechoic means neither having nor producing echoes and is a shielded room whose walls have been covered with a material that absorbs so much of the incident energy that it can simulate free space. The anechoic chamber measures the isotropic (all directions) gain pattern of an antenna. These measurements are taken at different angles and frequencies. Goddard Anechoic chamber has been used for decades to test both prototype and flight antennas affiliated with Goddard missions and outside entities. This paper presents the procedure and findings to measure, record, and document data for antenna testing, which includes the procedures to set up the chamber, measure antenna patterns, finding gain, axial ratio, and half power beam width, and adding beta cloth over antenna patch to assess any performance degradation

## Summary of Work/Results

I learned how to calculate input impedance and calibrate the PNA Analyzer. The cables needed to calculate the input impedance each were worth between \$500 and \$2,000. Each was used with delicate care. The calibrating process was a long process but once I finished that I had to put together components of a DPP 5.3 GHz antenna. When I was done I connected one cable end to the back of circular antenna figure and the other to the PNA analyzer. From here the process is too long to explain but I basically measured it and saved the data. Some of the images we saved in a certain file type on order for us to generate the codes for it to be used in MatLab When measuring this antenna on the PNA analyzer for its gain I had to make sure I kept it away from me since the antenna emits radiation.

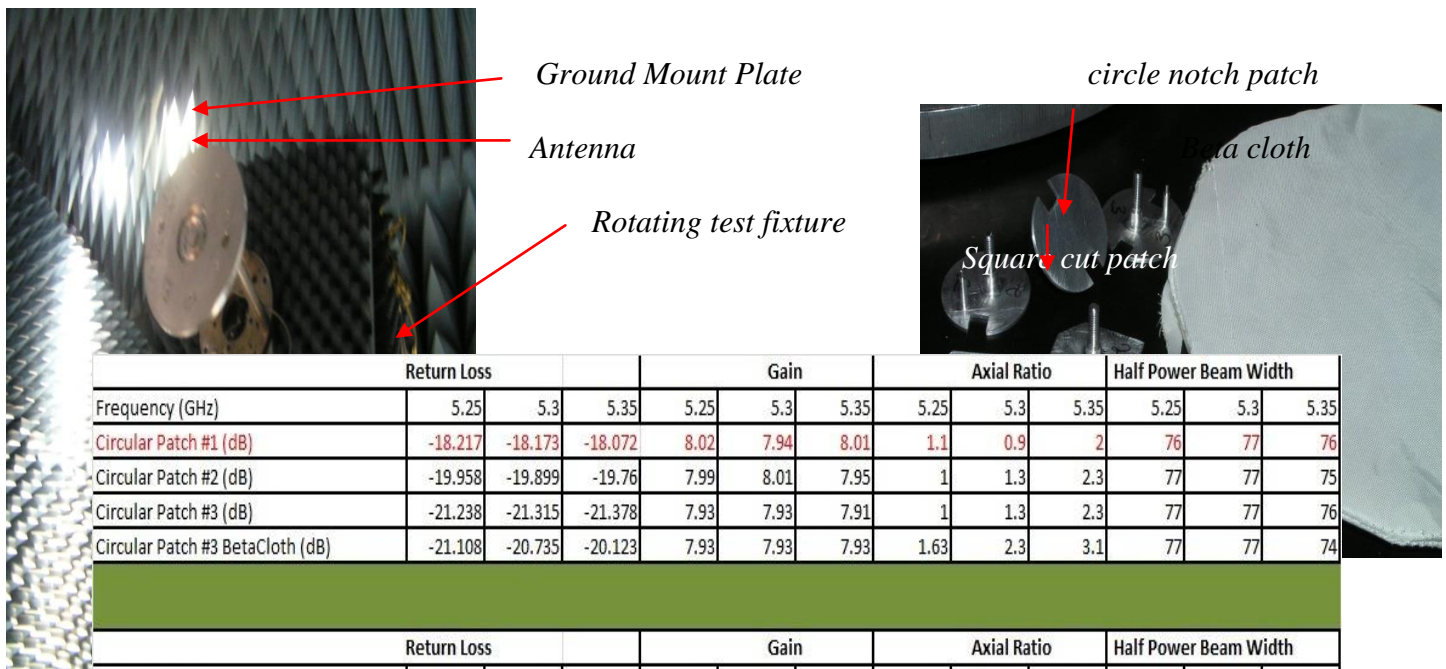


*Here is a picture of the PNA Analyzer with the cable connected to the outputs.*

*In this image the calibrated cable is connected to the back of the antenna figure. The antenna radiates so must be kept away from the body. The results are viewed on the computer.*

*Calibrated Cable*

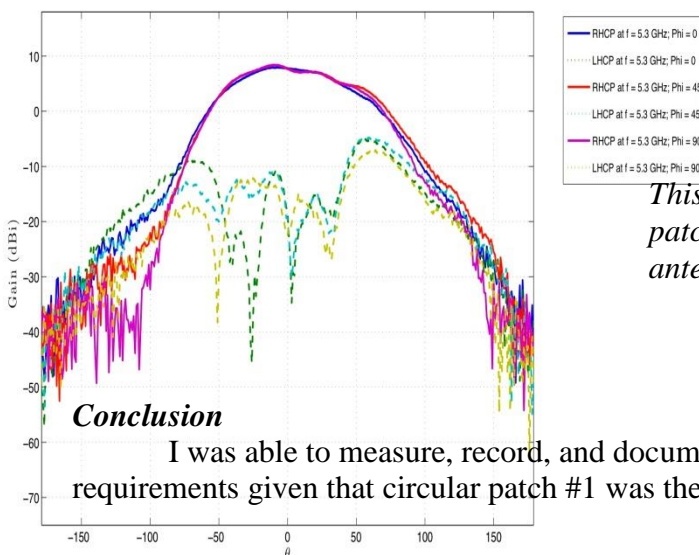
I used the antenna that I had constructed and mounted it on the test fixture of the chamber. My objective here was to run test sweeps of the antenna with different antenna patches on the one I had constructed. There were 6 antenna patches. 3 circular cut patches and 3 square patches each with different serial numbers. I would place one antenna patch on the ground plate then mount it on the chamber. Then I closed the chamber door and went over to the test station where I would use the computer to activate the sweep process. This took about 2 hours for each antenna patch to finish sweeping around in the chamber. When each was done I went back to the computer station to view the output result on the GAAMS software. This is a certain antenna software by Goddard used to work with the chamber simultaneously to view a graphical plot of the results. I was taught by both Victor and Steve on how to read the results and what exactly we were looking for. I was looking for the gain of the antenna, axial ratio, and for any inconsistencies.



	Return Loss			Gain			Axial Ratio			Half Power Beam Width		
Frequency (GHz)	5.25	5.3	5.35	5.25	5.3	5.35	5.25	5.3	5.35	5.25	5.3	5.35
Circular Patch #1 (dB)	-18.217	-18.173	-18.072	8.02	7.94	8.01	1.1	0.9	2	76	77	76
Circular Patch #2 (dB)	-19.958	-19.899	-19.76	7.99	8.01	7.95	1	1.3	2.3	77	77	75
Circular Patch #3 (dB)	-21.238	-21.315	-21.378	7.93	7.93	7.91	1	1.3	2.3	77	77	76
Circular Patch #3 BetaCloth (dB)	-21.108	-20.735	-20.123	7.93	7.93	7.93	1.63	2.3	3.1	77	77	74

	Return Loss			Gain			Axial Ratio			Half Power Beam Width		
Frequency (GHz)	5.25	5.3	5.35	5.25	5.3	5.35	5.25	5.3	5.35	5.25	5.3	5.35
Square Cut Patch #1 (dB)	-27.882	-28.403	-28.202	8.01	7.99	7.91	0.85	1.7	2.7	77	77	75
Square Cut Patch #2 (dB)	-26.257	-26.135	-27.529	7.91	7.88	7.89	0.7	1.45	2.4	77	77	75
Square Cut Patch #3 (dB)	-28.814	-28.692	-29.381	7.93	7.92	7.87	1.1	1.25	2.2	77	77	75

This table shows the return loss, gain, axial ratio, and half power beam width results from both circular and square cut patches that I measured in the chamber. Each test was run with either a circular patch or a square patch that had different serials. The one that was the best was the circular patch #1 because it met the requirements that were called for in this project.



This graph shows the measured radiation pattern of circular patch #1. It shows the principal cuts at each angle as the antenna is being rotated in the anechoic chamber.

**Conclusion**

I was able to measure, record, and document data for six antennas and concluded based on the requirements given that circular patch #1 was the best. It was noted that the beta cloth degrades the axial



ratio of the antennas when applied to the ground plate. It was also noted that the circular patch #1 at 5.3 GHz proved to meet the requirements needed and was thus the best out of all. The data and results will be recorded and tested one more time for flight usage.

**Enhancing Students' Hands-on Experience and Communication Capabilities through  
Mechatronics Engineering Program**

HOSSEIN RAHEMI, Ph.D.

Professor and Chairman, Department of Engineering and Technology, Vaughn College of Aeronautics and Technology, 86-01 23rd Avenue, Flushing, NY, 11369-USA, Email: [hossein.rahemi@vaughn.edu](mailto:hossein.rahemi@vaughn.edu)

SHOULING HE, Ph.D.

Assistant Professor, Department of Engineering and Technology, Vaughn College of Aeronautics and Technology, 86-01 23rd Avenue, Flushing, NY, 11369-USA, Email: [shouling.he@vaughn.edu](mailto:shouling.he@vaughn.edu)

# **Enhancing Students' Hands-on Experience and Communication Capabilities through Mechatronics Engineering Program**

## **Abstract**

This paper details the development process of senior-level mechatronics courses which cover comprehensive knowledge of Mechanical, Electronic, Computer and Control Engineering. The overall course objective is to provide mechatronics engineering students an opportunity to work together on software and hardware design with cross-coupled mechanical, electronic and computer subsystems. Meanwhile, considering the cross-disciplinary nature of the mechatronic engineering, we explore various approaches to enhancing students' communication and collaboration capabilities based on their solid theoretical knowledge and rich hands-on experience learned from different courses. Students are required to take the course of Computational Methods in Engineering to intensify their skills of critical thinking and problem solving and they are organized to work on course projects in a team. Furthermore, with the help of faculty members, they develop their course projects or innovative ideas into conference papers or tutorial/postal topics and present them in educational and technical conferences. Their performances working in a team and dialogue with professionals in the field, will build up their confidence and skills for their future jobs in the area of mechatronic engineering.

## **OVERVIEW**

To enhance students' communication capabilities through mechatronic engineering program, this paper will specifically address the following topics

1. Implementing teamwork and classroom presentation in core computational project-based courses.
2. Implementing teamwork and classroom presentation in hands-on project-based senior-level courses.
3. Assisting and engaging students in technical competitions and conference participation.

The implementation of teamwork and classroom presentation in core computational project-based and hands-on core courses not only improve students understanding about problems and solutions related to the engineering systems, but also, strength and enhance their critical thinking and communication skills.

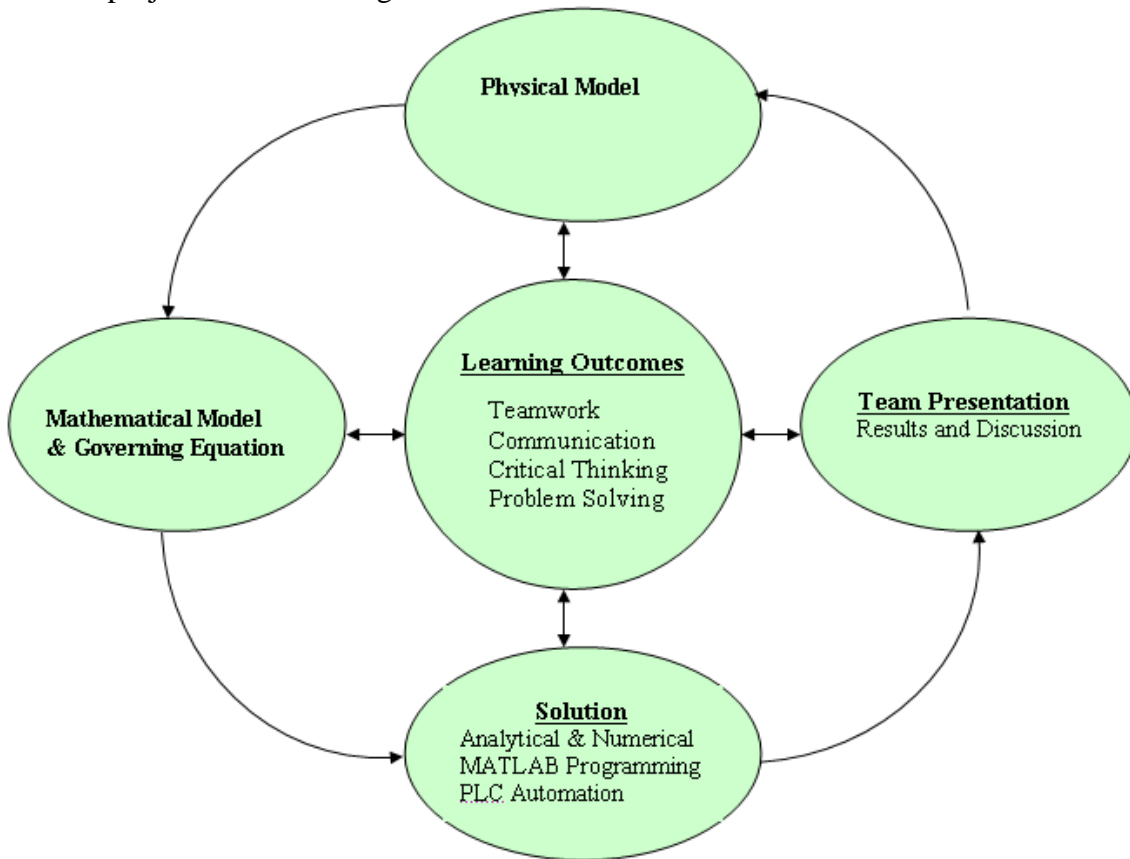
## **Introduction**

Mechatronics Engineering is a relatively new area that integrates mechanical, electronic, computer and control engineering together to design smart products that exhibit precise performance. With the rapid changes in industries as well as the ready availability of low-cost microprocessors, more and more products are becoming mechatronic in nature. Engineers are facing the challenge of having knowledge in multi- and interdisciplinary areas and working in team with people in a broad range of professional disciplines. Therefore, it is necessary to develop new program and courses that provide students with both theoretical knowledge and practical cross-platform skills as well as the strong communication and collaboration capabilities to work with people in different areas.

This paper will present the development process of core courses that can incorporate cross-disciplinary knowledge teaching, computational project-based learning, critical thinking and hands-on experiences into a curriculum through the Mechatronics Engineering program. The development process is based on a model that can improve students' communication, teamwork, and problem solving skills. This model introduces and engages students with the real-world applied problems/projects that incorporate research, analysis, teamwork, and classroom presentation. Furthermore, this study will also address on a process that can enhance teaching and learning effectiveness through core courses in enhancing and achieving those learning outcomes. This paper will specifically address senior-level engineering courses such as engineering analysis (project-based learning), fundamental mechatronics, and advanced mechatronics (hands-on projects) that incorporate teamwork and classroom presentation.

### Computational and hands-on project-based learning

The aim is to implement a methodology based on computational and hands-on project-based learning model [1], [2] such that to improve and enhance students' hands-on experiences, problem solving skills and communication capabilities through the new Mechatronics Engineering program developed at Vaughn College of Aeronautics and Technology. Figure 1 shows the graphical model of computational and hands-on project-based learning.



**Figure 1: Computational and Hands-On Project-Based Learning Model**

To provide students with the skills needed in Mechatronics Engineering, the department has developed a state-of-the-art **Automation Mechatronics Laboratory** to provide students opportunities to gain hands-on experiences and PLC programming skills. This laboratory is equipped with a small-size industrial mechatronics system (IMS) and with eight sub-systems, i.e. Sorting, Assembly, Processing, Testing, Storage, Routing, Disassembly, and Buffering sub-systems. Each sub-system (or the whole system) can be controlled by a programmable logic controller (PLC). (Siemens S300 PLC has been used for this automation control purpose.) In addition, The IMS sub-systems lab course is supplied with the state-of-the-art Virtual IMS 3D Simulation Environment, which enables instructors and students to design & test Mechatronics sub-systems, flexible manufacturing configurations, and control programs before assembly of physical components.

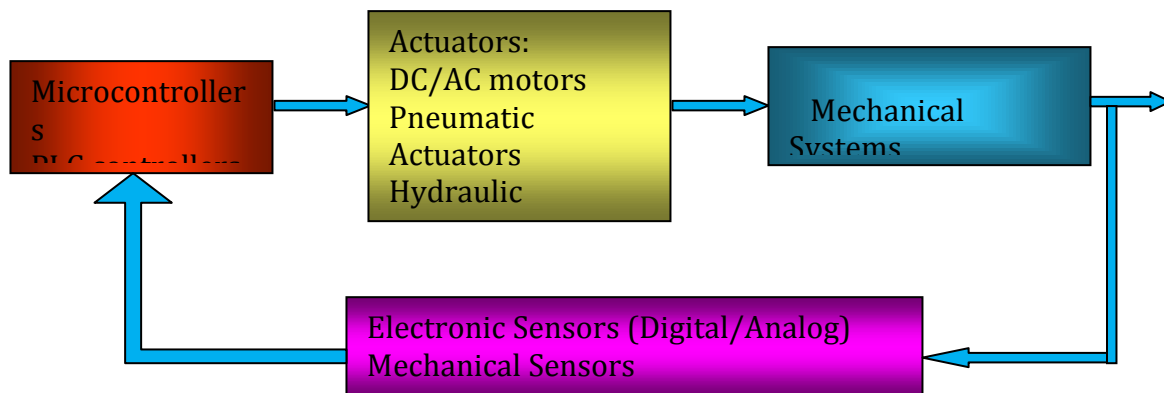
The laboratory facilities are used to teach the course of Fundamentals of Mechatronics - PLC programming and basic concepts of industrial automation. The electronic document, UniTrain-I, developed by the Lucas-Nuelle company, has been exploited to explain the sub-systems and demonstrate their programming process. Through the course and laboratory exercises, students have the opportunity to work with sensors, devices that convert mechanical and physical variables into electrical output signals, as well as a programmable logic controller (PLC), a computing device that manages and regulates the behavior of a mechatronic system. To the end of the course, students are expected to have

basic knowledge of sensors and devices as well as how they are used in industrial automation. In particular, they should be able to program the PLC controller to solve certain problems in PLC controlled automation lines.

### Advanced students' problem solving skills

In an effort to improve and enhance students' critical thinking, problem solving, and teamwork learning outcomes, the engineering and technology department implemented a computational project-based learning model (Figure 1) through both computational method in engineering, and engineering analysis courses. In those courses students will be introduced to numerical methods based on both finite difference and finite element approaches. Students are arranged in several teams, each team is assigned to a technical project with a specific engineering application. The assigned project must be studied and investigated based on available mathematical principles and MATLAB computer programming [3]. The students' projects will be measured based on learning objectives that are identified in the course syllabus and will be graded based on the criteria such as proposal, model development, programming, analysis, report and presentation. Some of those students' computational-based projects were submitted and accepted for publication and presentation in technical conferences [2], [6], [9].

After students have successfully completed the essential courses for Mechatronics Engineering, such as Statics/Dynamics (for physical modeling), Computational Methods in Engineering (for critical thinking, mathematical modeling and numerical method studying), Fundamentals of Mechatronics (for PLC programming and industrial automation), Microprocessors (for digital control using microcontrollers) and Linear Control Systems (for basic control algorithms), students are advanced to senior-level courses in Mechatronics Engineering. In these courses, system designs, i.e. integrating mechanical, electronic and computer sub-systems into one system, and implementation of the designed systems are discussed. As shown in Figure 2, a typical mechatronic system can be separated into the following four parts [4], where the sensors provide feedback signals, controllers generate the control signals based on provided regulation algorithm, and actuators are used to produce required forces/torques so that the mechanical systems (or physical systems) can behave as desired.



**Figure2: A Mechatronic System**

The courses start : programming and PLC programming. Since students have learned the working principle of microprocessors, microcontrollers and PLC programming, as well as programming microcontrollers and PLCs, they are guided to wire some components such as LEDs, LCDs and keypads with a microcontroller shortly.

After the procedure, the working principles of different sensors will be reviewed and further studied, such as positioning sensors (potentiometers), proximity sensors (infra-red sensors), ultrasonic sensors, velocity sensors (tachometers), force sensors, temperature sensors, and light sensors, etc. Especially,

students are required to wire these sensors with microcontrollers, program A/D converter and demonstrate the measurement are correct. (Notice that the difference of the courses from Fundamentals of Mechatronics is that they need to design and implement the measurement system here. Previously, they only need to obtain the measurement from pre-fabricated devices.)

Next step of the courses is to discuss different actuators. Students are supervised to find drivers or build drivers so that they can wire microcontrollers to DC motors, stepper motors and so on. In addition, pneumatic actuators and hydraulic actuators are also discussed in the lectures. Since microcontrollers, sensors and actuators have been studied step-by-step, students are required and encouraged to build some simple closed-loop mechatronic systems, for example, a temperature sensor and fan system or a light tracking system.

The last content of the advanced mechatronics courses is the closed-loop control system design. Since students have learned the principle of control systems, i.e. root loci method and bode plot method, the practical control system design [5] will be discussed here, for example, how to use an operational amplifier to build an analog controller, how to design a control system in discrete-time domain, and how to implement P, PI, PD and PID controller using analog circuits, microcontrollers, PLCs and so on.

Once four sub-systems of a typical mechatronic system, especially the industrial control algorithms, have been studied and implemented, students are required to complete a course project. In the project, students must use sensors, controllers, and actuators to build a mechatronic system. Furthermore, in the project report, students need to clearly indicate how each of four parts works in the system. Especially, the development of the control algorithm, i.e. how the control algorithm is explored to satisfy the system requirements, needs to be described.

The advanced mechatronics courses help students understand how to substantially design a mechatronic system. Besides, the system design and troubleshooting process in physically implementing a control system using microcontrollers, sensors and actuators increase students' capability for practically problem solving.

### **Students' engagements and activities**

In the core courses (computational method in engineering, finite element analysis, fundamental of mechatronics, and advanced mechatronics) students are assigned to projects that are involved with analysis, programming (MATLAB, C++, PLC, and Lab@Soft), report, and presentation. Students' best innovative projects will be selected and assisted by faculty advisors for the publication and presentation in regional, national, and international engineering conferences [6], [7], [8], and [9].

For the past four years the engineering and technology department created many activities to enhance students' hands-on experience and communication capabilities through engineering and engineering technology programs. Some of those activities and engagements can be categorized as follows

- **Industry Connection Seminar:** In Fall 2008, engineering and technology department established an industry connection seminar. This seminar is designed to enhance students' learning outcomes related to communication and problem solving. Given the rapid pace of technological change, the industry connection seminar is intended to assist the students in developing a mind-set that changes in technology are constant and that lifelong learning is necessary to meet future professional challenges. We invite guest speakers to the College to discuss a topic related to engineering and technology.
- **Robotics Club:** Robotics club has been established to motivate students' innovative mind and enhance their hands-on experiences in mechanical and mechatronics engineering programs. The

club is able to develop many innovative robots for both robotic competition and conference publications.

- **Robotic Workshop:** This workshop is given by robotics club to new students to introduce them with the development process of robots and their functionality. Students in this workshop will learn about various sensors, devices that convert mechanical and physical variables into electrical output signals, and actuators.
- **Vaughn College Journal of Engineering and Technology (VCJET):** This journal *is published annually in preparation for the Technology Day Conference*. This Journal includes events/activities of engineering & technology department, student's engagements, robotics competition, mechatronics poster competition, conference presentation and publishes the best student's research papers for the technology day presentation.
- **Vaughn College Annual Technology Day Conference:** The morning session is a meeting with the industry advisory council members. In this meeting the industry advisory members will be updated with annual departmental activities related to programs, accreditations, internships, students' activities and engagement. *In the afternoon session, students present their research and capstone degree projects in a paper format to the industry advisory members* (Sikorsky, RCM-Tech, Rockwell Collins, Paxon Manufacturing Group, FAA, CDI-Aerospace, U.S. Didactic, Int. Communications Group (ICG), Con-Edison), faculty and students from Vaughn College and Colleges in articulation with Vaughn College. Four judges, two from industry advisory members and two from faculty members, will evaluate students work. The top three papers will be selected as the recipient of the best student paper award of this session.
- **Conference Participation and Publication** – Students are encouraged and assisted by faculty advisor to work on an innovative research for their capstone degree project. For past couple of years, students in both mechanical and mechatronics engineering were able to participate, present and publish papers in engineering conferences. The following are list of conference proceedings publications of students' papers from 2009 to 2011.
  1. Daryl Gruar, "**Automation of Hawer Beechcraft B200/B300 Aircraft – CARGO Door**", presented at the ASEE Mid-Atlantic Conference at ITT-Technical Institute, Oct. 23-24. 2009.
  2. Brian Linhares, Sharifa Happy, "**Agricultural Improvements through Mechatronics**" presented at ASEE Mid-Atlantic Conference at ITT-Technical Institute, Oct. 23-24. 2009.
  3. Daryl Gruar, "**Automation Process of "King Air" Aircraft-Cargo Door Design**", presented at the ASEE Conference for Industry and Education Collaboration (CIEC), Palm Springs, CA, February 3-5. 2010.
  4. Shazim Baksh, "**Finite Difference Impulsive Response Analysis of a Frame Structure – A MATLAB Computational Project-Based Learning**", proceedings of the 8<sup>th</sup> Latin American and Caribbean Conference for Engineering and technology {LACCEI}, Arequipa, Peru, June 1-4, 2010.
  5. Brian Linhares, "**Mechatronics in the Advancement of Public Safety Control**", proceedings of the 8<sup>th</sup> Latin American and Caribbean Conference for Engineering and technology {LACCEI}, Arequipa, Peru, June 1-4, 2010.
  6. Marvin Blackman, Shahidul Islam, Joseph Kamel" **Innovative Cargo Screening Using a PLC System**" Proceedings of the ASEE St. Lawrence Section, Excelsior College, Albany, NY., March 18-19, 2011
  7. Marvin Blackman, Shahidul Islam, Joseph Kamel" **Counterbalance Transportation** " Proceedings of the ASEE Annual Conference, Vancouver, Canada, June 26-29, 2011.

8. Brian Linhares, “**Mechatronics in the Advancement of Transportation Security**”, proceedings of the 9<sup>th</sup> Latin American and Caribbean Conference for Engineering and technology {LACCEI}, Medellin, Colombia, August 1-4, 2011.
9. Marvin Blackman, Shahidul Islam, Joseph Kamel” **A PLC Automated Security Checkpoint**” Proceedings of the 9<sup>th</sup> Latin American and Caribbean Conference for Engineering and technology {LACCEI}, Medellin, Colombia, August 1-4, 2011.

- **Robotic Competition** - In past three years Vaughn College Robotics teams were active participant in both national and international Vex Robotics World Championship competition. On November 20, 2010, two groups (VCT1 and VCT2) of Vaughn College robotic team ( Brian Linhares, Chandra Mauli, Marlon Medford, Kinlok Poon) participated in VEX robotics competition at the California University of Pennsylvania. The teams won the competition with 2nd and 3rd places, respectively.
- **Poster Competition** – Students in both engineering and engineering technology programs are assisted and encouraged by faculty advisors to present their innovative research project in poster competition of technical conferences. For past couple of years our students in mechatronics engineering and mechanical engineering technology were able to participate in regional and national poster competition of American Society for Engineering Education (ASEE) and international poster competition of the Latin American and Caribbean Consortium of Engineering Institutions (LACCEI). In LACCEI 2010, our students were selected as the recipients of 2<sup>nd</sup> and 3<sup>rd</sup> place achievements award of the LACCEI poster competition.

### **Internship programs and industry involvement**

Internship program is a key part of an engineering curriculum to prepare students for the workplace. For past several years, our students were involved with both summer and during-year internship programs with top engineering companies such as Sikorsky, Northrop Grumman Corporation, Lockheed Martin, RCM-Tech, Rockwell Collins, Federal Aviation Administration (FAA), and MTA. In summer 2011, two of our Mechatronics Engineering students participated in a NASA internship program at the Goddard Space Flight Center in Greenbelt, MD. They worked on a project related to design and development process of a robotic arm for use on the International Space Station. This project provided them a greater appreciation for engineering education and expanded their hands-on and carrier-building experiences. As a result of those internship programs, many of our graduates are currently working with those industries and as new advisory members for our programs, assisting our current students in pursuing internship with those companies.

At Vaughn College the industry advisory members have pivotal role in the program delivery and students’ success. The industry advisory members work closely with faculty members of engineering and technology department in new course offering and program modification. Their valuable recommendations and comments will continuously make our program delivery stronger and more competitive with the growing demand of today’s technology. Furthermore, the close partnership with these industrial companies, such as NASA, Sikorsky, Northrop Grumman Corporation, Lockheed Martin, RCM-Tech, Rockwell Collins, Pavon Manufacturing Group, FAA, CDI-Aerospace, U.S. Didactic, Con-Edison, and MTA, allowed our students to explore an internship opportunity with top engineering enterprises. These internship programs provided our students with the needed career-building and hands-on experiences and a mind-set to adapt the fast changes and challenges in technologies.



## Conclusions

In this paper, we have discussed the development of the Mechatronics Engineering program at Vaughn College of Aeronautics and Technologies. In addition to traditional programs, the new curriculum and course arrangement address on students' hand-on experiences and collaboration and communication capabilities. Besides, we have industry involved in the departmental events, resulted programs that satisfy today's industry technological demands and produce graduates who are well prepared for both workplace and graduate study. In particular, internship and capstone degree project provide our students with valuable hands-on and carrier-building experiences.

For past several years, our students participated in many technical conferences, competitions and internship programs. Through all, our students were engaged with projects that not only required implementation of state-of-art tolls and technology but also to enhance student's critical thinking, problem solving, teamwork, leadership, and entrepreneurship activities. More than 90 % of our engineering and engineering technology graduates were able to land an engineering position immediately after their graduation (Sikorsky Aircraft, Northrop Grumman Corporation, Lockheed Martin, RCM-Tech, Rockwell Collins, Pavon Manufacturing Group, FAA, CDI-Aerospace, Con-Edison, and MTA) and many others were able to start their graduate work in well-known graduate schools (Virginia Tech, Texas A&M, Columbia University, City University of New York, and etc.).

## Reference

- [1] Rahemi, Hossein and LaVergne, Paul, "Engineering Analysis with MATLAB programming-An approach to enhance teaching and learning effectiveness" Paper presented at seventh LACCEI International Latin American and Caribbean Conference for Engineering and Technology, June 02-05, 2009, San Cristobal, Venezuela
- [2] Rahemi, Hossein and Baksh, Shazim, "Numerical Impulsive Response Analysis of a Frame Structure – A MATLAB Computational Project-Based Learning" Paper presented at eighth LACCEI International Latin American and Caribbean Conference for Engineering and Technology, June 01-04, 2010, Arequipa, Peru
- [3] Hossein Rahemi, and Baksh, Shazim "Finite Difference Impulsive Response Analysis of a Frame Structure – A MATLAB Computational Project-Based Learning", Latin American and Caribbean Journal of Engineering Education (LACJEE), Vol. 4, No. 2, pp. 31-38, 2010. © LACCEI, ISSN 1935-0295.
- [4] Bolton, William, *Mechatronics: A Multidisciplinary Approach*, 4<sup>th</sup> Edition, Prentice Hall, 2008.
- [5] He, Shouling, "A hardware platform for implementing control system designs on the Quanser DC motor control trainer", Proceedings of the ASEE St. Lawrence Section, Excelsior College, March 18-19, 2011, Albany, NY.
- [6] Daryl Gruar, "**Automation Process of "King Air" Aircraft-Cargo Door Design**", presented at the ASEE Conference for Industry and Education Collaboration (CIEC), February 3-5, 2010, Palm Springs, CA.
- [7] Brian Linhares, Sharifa Happy, "*Agricultural Improvements Through Mechatronics*" presented at ASEE Mid-Atlantic Conference at ITT-Technical Institute, Oct. 23-24. 2009.

- [8] Marvin Blackman, Shahidul Islam, Joseph Kamel” **Innovative Cargo Screening Using a PLC System**” Proceedings of the ASEE St. Lawrence Section, Excelsior College, March 18-19, 2011, Albany, NY.
- [9] Marvin Blackman, Shahidul Islam, Joseph Kamel” **Counterbalance Transportation System**” Proceedings of the ASEE Annual Conference, June 26-29, 2011, Vancouver, Canada.

## **Hardware and software development for cryogenic detector measurement**

L. Ralph  
Department of Engineering  
Virginia State University  
Petersburg, VA 23806

Singli Garcia-Otero, Ph.D.  
Department of Engineering  
Virginia State University  
Petersburg, VA 23806  
804.524.8989 X 1126  
Fax: 804.524.6732  
[sgarcia-otero@vsu.edu](mailto:sgarcia-otero@vsu.edu)

E. Sheybani  
Department of Engineering  
Virginia State University  
Petersburg, VA 23806

# Hardware and software development for cryogenic detector measurement

L. Ralph, S. Garcia-Otero, E. Sheybani

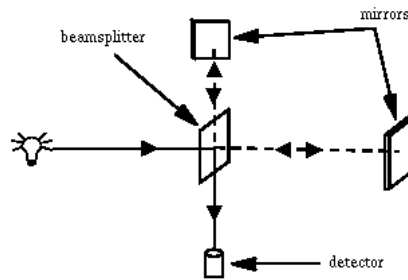
## ABSTRACT

For many years, a goal in detector development has been the realization of both high energy resolution and high efficiency within the same detector. It has become apparent that to achieve this aim it will be necessary to operate the detector at very low temperatures, as close to 0° K as possible. Cryogenics is the study of the production of very low temperatures. It involves how to produce them, and how materials behave at those temperatures. Cryogenic particle detectors are radiation sensors that operate at very low temperature, typically only a few degrees above absolute zero. The most commonly cited reason for operating any sensor at low temperature is the reduction in thermal noise.

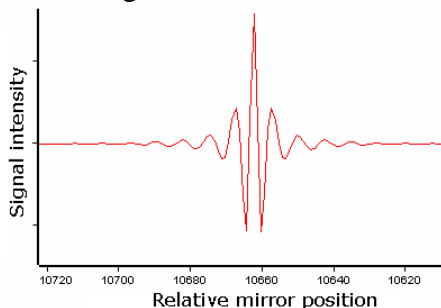
In this paper, cryogenic detectors and cooling technologies are presented. The improved performance of cryogenic devices, such as sensors and cold electronics, has opened new science applications. One of the main aims is to develop future refrigerators for the utilization of cryogenic detectors in space.

## SUMMARY AND RESULTS

FTS stands for Fourier Transform Spectrometer. It is used to study the light spectrum. Below is a diagram showing how it works.

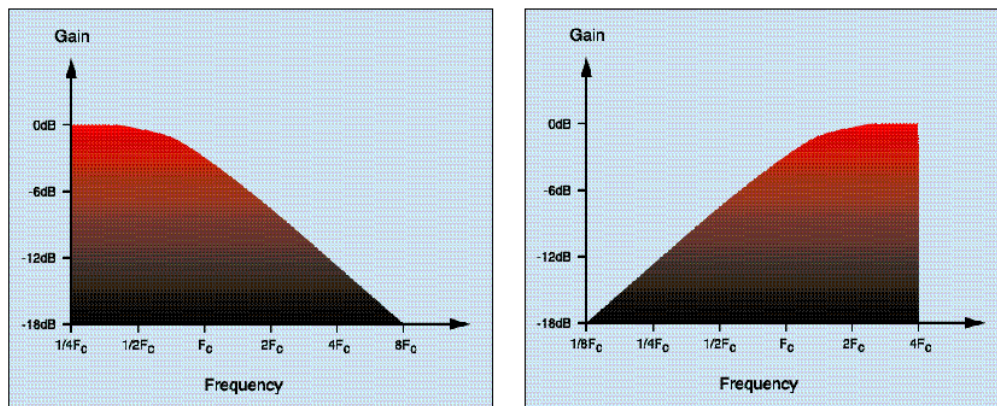


A beam of light will travel through the FTS and hit a beamsplitter that sits at a 45 degree angle. The beam of light is split into two beams, each hitting a mirror. The mirrors make a 90 degree angle, one mirror is fixed and one is mobile. The two mirrors will reflect the beams of light back to the beamsplitter where they interfere and leave the FTS through the detector. Below are the results.

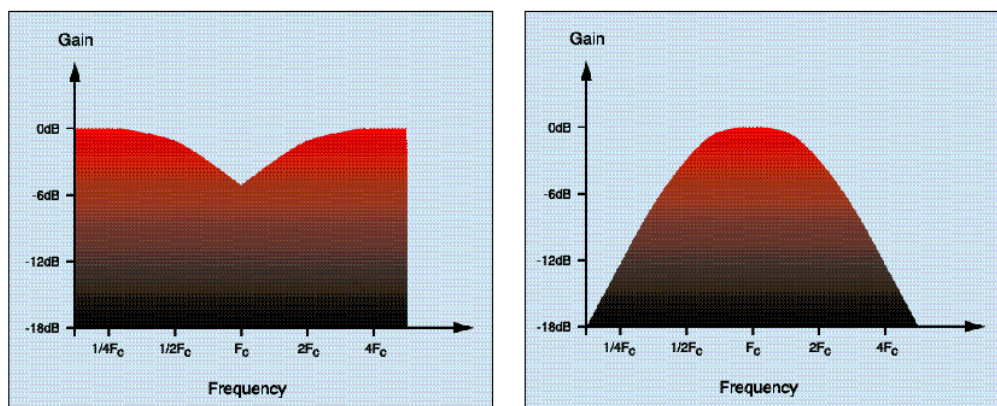


The peak at the center is the ZPD position ("Zero Path Difference"). Here, all the light passes through the interferometer because its two arms have equal length. As the two beams cancel each other out, the signal becomes a straight line.

Next, low pass, high pass, and band pass filters were studied and the frequency of each filter was measured using the network analyzer. A low-pass filter is a filter that passes low frequency. Figure 1(a) below shows the results of a low pass filter. Most low pass filters have a cut-off point of about 2 GHz. These particular filters allow all signals below 2 GHz to pass through. Any signal above 2 GHz is blocked from the filter. A high-pass filter's task is just the opposite of a low-pass filter: to offer easy passage of a high-frequency signal and difficult passage to a low-frequency signal as shown in Figure 1(b). Most of the filters used had a cut off frequency of about 40 GHz. This means the filter pass signals only if the frequency is 40 GHz or above. If any frequencies below 40 GHz entered the filter, the signal would be blocked. There are applications where a particular band, or spread, or range of frequencies need to be filtered from a wider range of mixed signals. Filter circuits can be designed to accomplish this task by combining the properties of low-pass and high-pass into a single filter. The result is called a band-pass filter as shown in Figure 1 (d). Band pass filters pass signals within a range of frequencies. The band pass filters have a high and a low cut-off point. Most of the filters that were measured had a frequency range from 3.1 to 3.9 MHz. All signals with frequencies below 3.1 and above 3.9 are blocked from the filter.



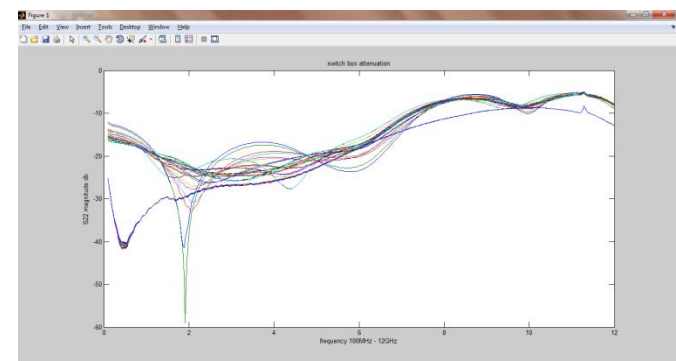
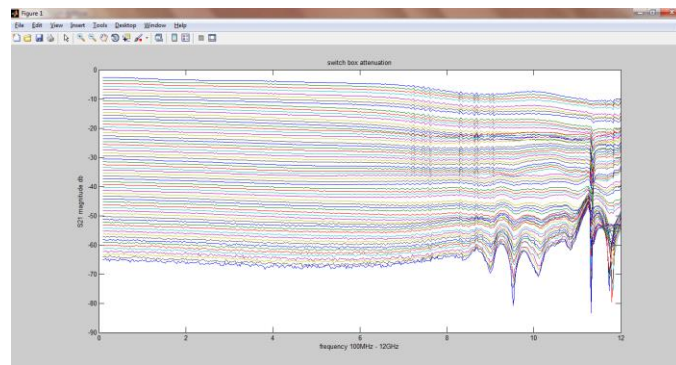
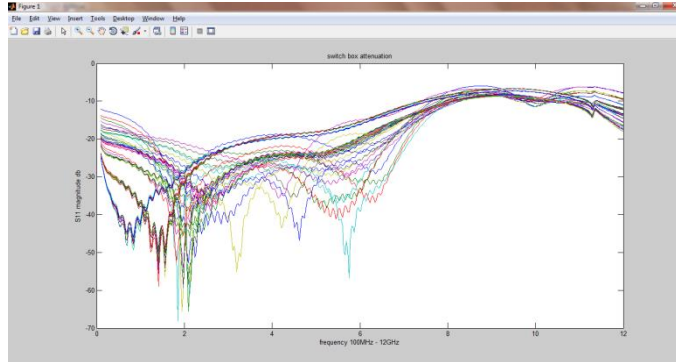
Figures 1(a) and 1(b): 6dB/octave (one-pole) low-pass and high pass filters.



Figures 1(c) and 1(d): Band-reject and band-pass filters.

The third and final way to detect sound is with an attenuator and a control mechanism. A control box for a programmable attenuator was built. An attenuator is an electronic device that reduces the amplitude or power of a signal without appreciably distorting its waveform. An attenuator is effectively the opposite of an amplifier, though the two work by different methods. While an amplifier provides gain, an attenuator provides loss (gain less than 1). The box was designed for the attenuator has six switches and six LEDs. Each switch represents a power of two and the binary range is from 0 to 63 dB, in addition, there is a main switch that controls all of the other switches. Each switch is connected to an LED and to

each pin of the attenuator. The box is then connected to a power supply measuring 5 volts. The attenuator is connected to the box and to the network analyzer. From the network analyzer, one can measure loss of the attenuator. The programmable attenuator has an attenuation level of 3.5 dB. After the other switches were turned on, the attenuation levels began to change. Below are the graphs for each s-parameter.



## CONCLUSION

In conclusion, cryogenic detectors and cooling technologies have made a remarkable amount of progress over the last 20 years. The increased reliability and simplicity of operations of cryogenic equipment have allowed operation on spacecrafts, while the improved performance of cryogenic devices, such as sensors and cold electronics, has opened new science applications. One of the main aims is to develop future refrigerators for the utilization of cryogenic detectors in space.

## **Partnerships and Experience in Building STEM Pipelines**

**PATRICIA A. S. RALSTON**

Department of Engineering Fundamentals,  
J.B. Speed School of Engineering,  
University of Louisville,  
Louisville, Ky 40292

**JEFFREY L. HIEB**

Department of Engineering Fundamentals,  
J.B. Speed School of Engineering,  
University of Louisville,  
Louisville, Ky 40292

### **DR. PATRICIA RALSTON**

Dr. Patricia Ralston is currently Professor and Chair of the Department of Engineering Fundamentals and an Associate Professor in the Chemical Engineering Department at the University of Louisville. Her research interests include the use of Tablet PCs in engineering education, retention in undergraduate engineering programs, and process monitoring and fault detection including cyber-security for SCADA systems.

### **DR. JEFFREY HIEB**

Dr. Jeffrey Hieb is currently an Assistant Professor in the Department of Engineering Fundamentals at the University of Louisville. His research interests include the use of technology in engineering education, secure operating systems and cyber-security for industrial control systems.

## Partnerships and Experience in Building STEM Pipelines

### Abstract

In 2007, University of Louisville School of Engineering charged the newly formed Department of Engineering Fundamentals to develop a K-12 outreach program. The program's goal is to increase the number of students interested in and capable of studying STEM fields in college. To organize, guide, and focus department outreach efforts, the department developed and implemented a plan to create STEM pipelines in the Jefferson County Public Schools. The pipelines are currently comprised of selected elementary and middle schools that send students to the engineering magnet high schools. The elementary program uses the Boston Museum of Science's (BMOS) curriculum, "Engineering is Elementary®" (EiE), and the engineering school is partnering with BMOS to spread the use of EiE. For selected middle schools, the "In the Middle of Engineering" (IME) program was developed in collaboration with interested middle school science teachers. The EiE and IME programs are in their fourth year, with nineteen participating schools. A comprehensive plan is in place to expand these initiatives throughout the county and state. Analysis of initial assessment data, collected from second and third graders and in partnership with BMOS, indicates positive impacts by the EiE program. EiE students showed a statistically significant improvement on science and engineering understanding. Also, students are filling the pipelines as indicated by recent increases in students who request middle schools that have IME programs based on positive experiences in EiE, and increases in students who choose targeted high schools as they leave middle school programs with IME. Several challenges remain in expanding the STEM pipelines; the most significant of which are moving successful programs to self-sustaining ones, and identifying and collecting assessment data about students in these programs, and finally tracking their progress through the pipelines to college.

### Background: The Need for a Pipeline

The creation of a robust K-12 STEM pipeline has been widely identified as critical to the future of America's global competitiveness and is based on the research of experts who have produced concrete recommendations in the NAS Gathering Storm Report from 2005<sup>19</sup>, Project Kaleidoscope Report on Reports II<sup>18</sup> and the President's American Competitiveness Initiatives of 2007<sup>17</sup>. Locally, the Kentucky Council on Postsecondary Education STEM Task Force<sup>11</sup> has developed a state-wide strategic plan to accelerate Kentucky's performance within STEM disciplines. Both the STEM Task Force and the National Science Board<sup>1</sup> recognize the need to form strategic partnerships that inform K-12 students and parents about engineering. Despite these reports and recommendations three to five years ago, updated reports *Rising Above the Gathering Storm: Two Years Later* and *Rising Above the Gathering Storm, Revisited: Rapidly Approaching Category 5*<sup>23,24</sup> show progress is not on target to address the needs, especially concerning the number one priority of improving K-12 science and mathematics education. A book published by the National Academy of Engineering and the National Research Council reviews the scope and impact of engineering education in K-12 classrooms<sup>25</sup>. *Engineering in K-12 Education* makes several recommendations to address curriculum, policy, and funding issues. The book also analyzes a number of K-12 engineering curricula in depth and discusses what is known from the cognitive sciences about how children learn engineering-related concepts and skills. These reports clearly indicate a lack of a cohesive and effective national approach to K-12 engineering education. Furthermore there is general agreement that increasing the number of students interested in and capable of studying STEM fields in post-secondary education is critical to our nation's future success. The American Society for Engineering Education, (ASEE) published an analysis of current practices and guidelines for the future<sup>9</sup> and is involved in an ambitious effort to improve K-12 engineering education and outreach.



## A Brief Review Outreach Programs for Engineering and K-12 Engineering Curriculum

The literature on outreach programs and outreach program assessment is vast. However, there is little information on assessment of K-12 engineering outreach programs<sup>16</sup>. A review of K-12 engineering outreach programs<sup>10</sup> describes several different models. The review notes that it has become clear to educators that students need to be introduced to engineering at an early age, and that K-12 teachers need assistance from engineers and engineering educators. It further states that all successful engineering outreach programs have a “do” or “hands-on” component, hearing or reading about engineers or engineering is not enough. Many universities are actively using outreach to promote STEM pipelines by offering workshops for students and teachers, hosting residential camps, competitions, conducting outreach activities at schools, conducting and sponsoring contests, developing materials and websites, and bringing students to campus for outreach activities.<sup>10,3,16,20,22</sup> Websites for most engineering colleges indicate that they offer one of these K-12 outreach approaches. Much of the recent published work still focuses on fairly small scale outreach efforts that are single camps reaching a limited number of high school students<sup>28</sup> or programs based around robotics or other competitions.<sup>27</sup>

Outreach programs by engineering colleges are an effective way to expose K-12 students to the engineering design process, engineering education, and engineering as a career. However, a growing body of research suggests the need to help K-12 teachers develop the ability for guiding the inquiry and design process of engineering and STEM hands-on activities and to support interactions with students as they tackle interesting problems. Some researchers question whether traditional outreach efforts are enough to attract the numbers of students needed in the STEM fields or if they can provide learners with the experiences needed to succeed in STEM fields in college. Engineering-based curricular material for K-12 classrooms addresses this issue, but there is limited data available on the efficacy and impact of these programs on key STEM learning outcomes. Effecting change requires building a cohort of teachers who can adopt and adapt engineering curriculum for their classrooms and achieve measurable results. Still needed is credible research results that demonstrate students’ achievement of important STEM learning objectives<sup>29</sup>. A creative way that engineering colleges can help improve K-12 STEM education is to create the teachers by providing K-12 teacher certification to engineering students. A small, but growing number of engineering colleges are offering general engineering degrees combined with K-12 teaching certification.<sup>26</sup>

Very recent research is underway to actually assess which programs are effective for learning and stimulating interest to pursue STEM fields in college. It is intended to be the first step in evaluating the ability of K-12 outreach programs to prepare students to study engineering in college<sup>30</sup>. This study was concerned with the association between types of engineering exposure (e.g., class, field trip, summer camp, etc.) and engineering self-efficacy. The results revealed that there was not a significant difference in self-efficacy scores between the students who participated in most engineering outreach experiences and those who did not. The only formal programs that produced significant differences in student self-efficacy were the semester-long, academically challenging, technology and pre-engineering courses. If it is true that participating in these classes can increase a student’s self-efficacy, engineering colleges interested in increasing the level of preparation of students in the engineering pipeline may benefit from being involved in formal K-12 technology and pre-engineering programs. In regard to informal experiences, significant differences in self-efficacy were found between students who had engineering-related hobbies and the students who did not. In particular, students who had the hobbies of programming, electronics, producing video games, robotics, and model rockets all had statistically significant higher self-efficacy scores. These hobbies share the elements of hands-on experiences, self-motivated learning, real life application, immediate feedback, and problem-based projects. The same

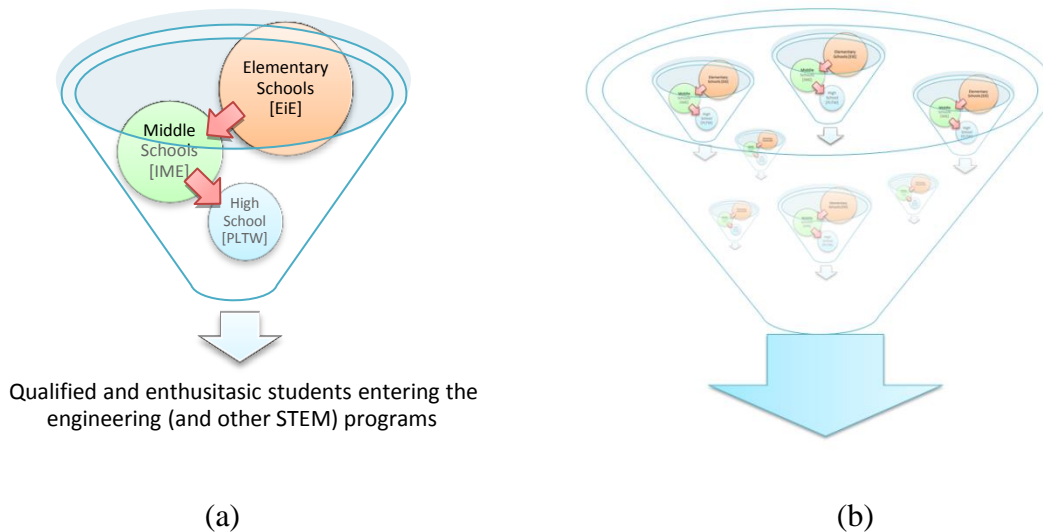
principles should be utilized by outreach programs when delivering content or in the general pedagogy of the program.

### **Pipeline Development – Goal: Develop, Sustain, and Replicate**

The J. B. Speed School of Engineering is building a successful pipeline within the local public school system, Jefferson County Public Schools (JCPS), which has more than 98,000 students. Speed School is in partnership with the Jefferson County Public School system, the Louisville Science Center, alumni, and increasingly, local industries. Through this partnership, young students will be exposed to the world of engineering and technology. The goal is to provide students with a foundation that prepares them for and encourages them to seek a STEM field of study in college, by promoting and spreading the “Engineering Is Elementary” (EiE) and “In the Middle of Engineering” (IME) programs discussed in the following sections. Through its participation in this partnership, Speed School specifically implements four of the six published ASEE guidelines: 1) working with hands-on projects at the elementary level, 2) engaging young science teachers by providing them with good curriculum, materials, training and mentoring, 3) targeting minorities and females, and 4) strengthening the existing partnership between higher education (Speed School), K-12 (JCPS), and to an important community partner, the Louisville Science Center (LSC) which can provide important guidance on teacher training.

Speed School’s approach shares many of the characteristics suggested by the current research. What makes Speed School’s outreach program unique is that it is a plan to create and implement targeted pipelines that “pull” students into engineering in elementary school and then mentors them through a pipeline that continues from elementary to middle school and on to engineering magnet high schools. The pipeline model combines the nationally recognized K-5 engineering curriculum for elementary students (EiE) with a locally developed middle school program (IME) and the successful Project Lead the Way (PLTW) high school program. A focused and effective partnership of Speed School of Engineering, Jefferson County Public School System, the Louisville Science Center with local industry and alumni, should be able to develop, sustain and replicate STEM pipelines from elementary through the college level throughout the local area and provide a model for others. The pipeline concept is illustrated in figure 1.

Speed School, via its Department of Engineering Fundamentals, was in an ideal position to initiate and build a partnership for outreach. One of the department’s specific missions is to create outreach programs to elementary and middle school students. When the department was created in April 2007, the Dean established a Director of Outreach term faculty position specifically for K-12 outreach. Through discussion and research, the department explored the best way to effectively perform outreach to our local elementary and middle school students, and this mission is part of the department’s ongoing strategic plan. The overall goal is to bring more interested and capable students to our engineering college, to effectively make use of resources, and to have a sustainable model that allows for continual expansion.



**Figure 1. A single pipeline (a) and many replicated pipelines (b).**

The overall pipeline concept was conceived in 2007 as a result of Speed’s relationship in 2006-2007 with a local elementary school (Wheeler Elementary). Speed also had a supportive relationship with the only PLTW high school in the county. Wheeler had started an EiE Program at the direction of the principal. Their EiE program was (and still is) an after-school activity offered every two weeks. Speed became involved in Wheeler’s EiE program at the request of the principal who wanted the students to see and talk to engineers, and also wanted Speed’s opinion of the program. Our Director of Outreach worked further with Wheeler in 2007-2008 to formalize our support for their EiE program. Everyone, including the Dean (who participated regularly), faculty volunteers, the elementary teachers, principal, parents, and students all agreed it was an unqualified success. Students had fun, learned about science, and more importantly, learned what engineering involved and what engineers do. With this success, the Engineering Fundamentals Department Chair and the Outreach Director, in coordination with the Science Center’s staff, researched and reviewed the EiE curriculum. Speed concluded that EiE was indeed effective curriculum that it should be encouraged in our local school system.

Speed’s experience with Wheeler offered an opportunity to effect systemic change: develop a mechanism to allow the Wheeler teachers and principal to share their knowledge and enthusiasm within JCPS so that more elementary schools might start EiE programs with support and mentoring offered by Speed, and with teacher and science/engineering education training provided with guidance from the Louisville Science Center. It was seen as critical that Speed School take a lead role in this new partnership to “pull” more young students into the pipeline, giving them ample opportunities to see and talk to engineering faculty, alumni, and college students and to receive guidance early on concerning what types of courses they should take in middle school and high school. In 2007-2008, there was only one high school with a PLTW program. Fortunately, Wheeler Elementary was one of several elementary schools that fed middle schools that eventually led to the PLTW high school. Our pipeline plan was to **target elementary schools and middle schools that would lead to the PLTW high school** and develop successful EiE or IME programs in those schools.

To complete one pipeline, we determined which middle schools fed the PLTW high school and also accepted students from Wheeler. Two middle schools were obvious targets: Carrithers and Newburg. Carrithers was the only middle school in the county with a Gateway to Technology program, which is the PLTW middle school program. Speed’s Outreach director started an IME program there and also

supports their Gateway to Technology program. Newburg Middle School had an enthusiastic science teacher that had requested a program when she heard about Speed's outreach program. An IME program was started at Newburg the same school year. Then additional elementary schools that feed these two middle schools were targeted as well as additional middle schools. The Outreach Director worked with the principals and teachers to systematically start EiE and IME programs at targeted elementary schools and middle schools. A critical supporting event was a 2008 summer teacher training to provide teachers from these newly targeted elementary and middle schools with the training needed to support EiE in their school. The EiE teachers from Wheeler, the IME teacher from Newburg, and Speed's Outreach Director demonstrated the curriculum and activities and showed how they supported the current science curriculum. In total, eighteen teachers participated with attendance from all the targeted schools. Also, in summer 2008, Speed also started working closely with the PLTW high school. The Outreach Director, working with the director of the PLTW program, hosted a summer camp for middle school students from the two middle schools, encouraging them to enter the PLTW program at the high school. Students visited Speed's Clean Room, Nano Technology, Bio-mechanics, and Rapid Prototyping Facilities, and Speed's faculty and students as part of the summer camp. These camps have continued every summer.

By the end of the 2008-2009 school year, principals and teachers at the two middle schools, five elementary schools, and the PLTW high school were excited about this new partnership and the developed pipeline and its potential to enlarge the number of students interested in and able to study STEM in college. Relationships were forged between Speed and the local school system at all points in the pipeline; what was needed was a mechanism to ensure these informal EiE programs could be supported within the school system itself, thereby enlarging the flow by getting more students in at the elementary level.

The Engineering Fundamentals Department received a small grant from the Boston Museum of Science who had a large Bechtel grant to create Regional Partners to help disseminate the EiE curriculum. This BMOS grant was for the 2009-2010 school year and supported more teachers. It also required the curriculum to be used in the science classes. The impact of this grant is discussed in a later section, but it did serve to expose the entire county system science support teachers to EiE and that has had a positive effect. However the school district science curriculum specialists do not embrace EiE to the point of selecting it to become part of the required curriculum. It is still up to individual schools to decide to incorporate various modules at appropriate times. Thus, there is still a need for external financial support of the EiE programs.

Since 2009, the outreach program continues to grow, and more schools have been added each year. Two additional IME programs are in place at middle schools that have very diverse populations; one is an all-girls academy. Additional pipelines are planned within the Jefferson County school system with this growth strategically encouraged to support two new engineering magnet programs started at high schools in the local system. Fortunately, many of the recently added middle schools will feed those high schools.

## **Outreach Programs**

The individual components of the Department of Engineering Fundamentals Outreach Program are presented next. They are the elementary curriculum, Engineering is Elementary (EiE), the middle school "hands-on" activities that augment math and science curriculum for middle school, In the Middle of Engineering (IME), and the Project Lead the Way (PLTW) high school curriculum. Two other additional support activities are also discussed briefly.

## Engineering is Elementary®

The most important part of any program is to have solid curriculum with hands-on learning activities, such as that provided by *Engineering is Elementary*®, (EiE) developed by Dr. Christine Cunningham of Boston Museum of Science. EiE is a set of 20 modular units with hands-on activities that incorporate engineering and technology concepts with elementary science objectives. These units align with the National Science Standards, the State Core Content for Assessment as well as the inquiry-based science module curriculum that the Jefferson County school system is currently implementing. The EiE development process is research-based and is clearly described in “Engineering is Elementary: An Engineering and Technology Curriculum for Children”<sup>7</sup>. Cunningham<sup>2</sup> reported in 2008 that 9,306 teachers and 484,081 students in more than 1200 schools in all 50 states had used EiE lesson materials. As of September 2011, the EiE website showed 26,744 teachers and 1,833,755 students using EiE. The work of Speed’s outreach program was instrumental in spreading the use of EiE in Kentucky.

The EiE curriculum introduces each unit with a story about a child with a problem to solve. Activities introduce the engineering foundation of design, using science concepts as the students help the child solve the problem. Soft skills are learned as students learn to work in teams, deal with failure, and learn to “try again”. **The next unit** lesson focuses on helping students develop a broader perspective on the unit's engineering discipline involved. Through hands-on activities, students learn more about the types of work done by engineers in these fields, and the kinds of technology they produce. The third unit lesson is designed to help students understand the linkages between science, mathematics, and engineering. Children collect and analyze scientific data that they can refer to in their final lessons as they create engineering designs to solve their problem. Some lessons may take longer than others, especially the initial introduction to the problem and the design and build lesson. Explanation of lesson plans is available from the Boston Museum of Science website ([http://www.mos.org/eie/lesson\\_plan\\_structure.php](http://www.mos.org/eie/lesson_plan_structure.php)).

EiE is a rigorously researched and assessed program.<sup>5,6,8,12,13,14,21</sup> Their research has shown it not only improves elementary students’ understanding of science concepts, but their understanding of technology and of engineers and why their job is important.

The EiE units are not an independent curriculum; but rather are designed to extend the learning that occurs in an existing curriculum. The units selected to be implemented in the each school will be ones that best align with the school system’s science module curriculum. JCPS is in their third year of a district-wide inquiry-based science curriculum implementation. The EiE units use the same inquiry-based pedagogy; therefore, students will have additional opportunities to learn science by doing science. Students will also extend their learning by applying and connecting the science concepts they learn in the classroom to their problem solving experiences in the EiE units. Some schools use EiE as part of their regular science class time, whereas a few schools use it as an after school or enrichment activity; but the units are selected to align with students’ science curriculum.

## Impact Assessment of EiE

The Outreach Program does not have a formal assessment component yet, however, there is some limited assessment of the impact of EiE on some of the participating students. Speed School and the Jefferson County school system participated in a grant from Bechtel administered by the Boston Museum of Science (BMOS) called the National Dissemination Through Regional Partners Project. BMOS provided the test instruments for teachers and students, and scored the assessments. The Speed School of Engineering at the University of Louisville worked to coordinate the study, soliciting principals,

teachers, and providing teacher training and support throughout the project. The study was carried out in 2009-2010. Student gains on general assessments of their understanding of technology and engineering and on EiE unit-specific assessments were examined. Sixteen grade 2 teachers used the EiE *Designing Walls* unit with their earth science unit, and 17 grade 3 teachers used EiE *Evaluating a Landscape* unit while doing a landforms science unit. *Statistically significant* improvement was found on unit assessments, (earth science unit), science sub-scores and engineering sub-scores; girls and boys improved equally well from the pre- to the post-assessment on all three scores. There was no control group in this study which limits the conclusions that can be drawn; however, it seems probable that much of the improvement is attributable to EiE. Table 2 shows Summary results from Unit Assessments of Students' Science and Engineering Understanding.

**Table 1. BMOS EiE Impact scores**

Unit	Score	Max Score	Mean Change in Score	95% CI	Pre	Post	Change
<i>Designing Walls</i> Grade 2	Overall	46	9.7	(8.7,10.8)	M>F	None	None
	Science	21	5.3	(4.8, 5.9)	M>F	M>F	None
	Engineer	24	3.1	(2.6, 3.7)	None	None	None
<i>Evaluating a Landscape</i> Grade 3	Overall	24	7.6	(6.8, 8.3)	None	None	None
	Science	12	3.1	(2.6, 3.5)	None	None	None
	Engineer	12	4.5	(4.0, 5.0)	None	None	None

### **In the Middle of Engineering**

Many students from the identified elementary schools will attend the targeted middle schools with “In The Middle of Engineering” programs. At one middle school, the IME after-school program supplements their Gateway to Technology Program. Gateway to Technology is the Middle School curriculum for Project Lead The Way, and consists of five independent nine week courses. This school refers to this as their Technology Immersion Program and it is a pre-engineering curriculum required for all students. They use Inventor Autocad software and students take all five courses: Design and Modeling, The Magic of Electrons, The Science of Technology, Automation and Robotics, and Flight and Space. The IME programs at all middle schools are developed in coordination with the science and/or mathematics teachers. Their strong point is the use of hands-on kits available from Slinky Science (<http://www.discoverthis.com/slinkyscience.html>), “Our Amazing Bridges”, “The Electro Lab”, “All About Gears” and “Solar Energy” which enhance topics covered in their Gateway to Technology and science and mathematics classes. The IME programs do not have engineering curriculum components per se, but augment the science and mathematics or Gateway to Technology programs.

Speed students help as young mentors and alumni have provided special assistance. An alumnus at the Core of Engineers comes to the school to give a presentation and answer questions during the modules on bridges, and an alumnus from the Louisville Water Company helps with the environmental module on clean water.

## **Project Lead the Way**

Project Lead The Way (PLTW) is a nationally accredited high school pre-engineering technology curriculum for aspiring engineers. It has been proven to prepare high school students for college/university engineering/technology curriculums, and is offered at only one high school in the Jefferson County system. The program's academically challenging curriculum includes a four-year sequence of five technical, mathematics, and science integrated courses that complement the honors/advanced mathematics and science courses required of pre-engineering/engineering technology students. The elementary and middle schools that were in the first identified pipeline funnel students to this high school. Speed has established a good, supportive relationship with this high school and is works with them to coordinate more closely with the targeted middle schools. Speed's Outreach Director also worked with them to offer week long summer camps each summer beginning in 2008, exposing many students to the University of Louisville campus.

## **Other Outreach Efforts**

Although Speed School did not have formal outreach programs for elementary and middle school prior to the creation of the Department of Engineering Fundamentals, the school's Director of Student Affairs (now a member of the EF Department) had organized and offered a summer program (INSPIRE) that targets under-represented minorities and females. In addition, due to the visibility and success of the elementary and middle school outreach programs, the department has begun offering summer camps in response to requests. These two activities will be briefly described.

## **INSPIRE**

**I**ncreased **S**tudent **P**reparedness and **I**nterest in the **R**equisites for **E**ngineering is a summer enrichment program for local high school students targeting female and ethnic minority students who traditionally are underrepresented in engineering fields. This four-week, half-day, non-profit program is designed to enable 20-30 participants to acquire a degree of understanding of the engineering fields through participation in laboratory-oriented studies. Participants typically will have completed the 9th, 10th or 11th grade, have above average math and science skills, a solid academic record, teacher recommendations and a commitment to participate for the full four weeks. This program has been in operation by Speed School of Engineering since 1981, with the following results: 692 participants from 1981-2011, 462 enrolled at the U of L, 175 were awarded a degree from U of L, and 80 were awarded a bachelors or Masters in Engineering. Just this year, Brown Foreman donated \$10,000 to enhance this program. With adequate funding, this four week, half-day camp might be re-designed to become a two or three week residential camp with a more focused curriculum.

## **Summer Camps**

The Outreach Director noticed that many of the middle school students had difficulty measuring things in the activity where students built a cardboard boat for a regatta contest sponsored by the PLTW high school. As a result, in 2009 he created "A Measure of Engineering" summer camp offered on campus at the engineering college. This camp focuses on measurement, geometry, scales, ratios, visualization and orthographic projection. Students use engineering drawing and measurement tools to participate in hands-on activities. Thirty students quickly filled the camp, and it was well received. As information about this camp and the other outreach programs grew, requests started coming in for additional camps, especially robotics camps. In response, the Outreach Director worked with schools and teachers that had robotics teams to support and partially fund four LEGO Mindstorms robotics

camps in 2010. These were offered at the Louisville Science Center and the local Planetarium. “A Measure of Engineering” camp was held again at Speed. The Outreach Director also supported and worked with teachers to offer two “bridge building” camps at a local private school. Summer 2011 was even busier, with five robotics camps held on campus, two of those for training of teachers and supported by our local UPS hub. “A Measure of Engineering” and the “bridge building” camps were also held. Support was given to and “Engineering Adventures” camp held at one of the more active elementary schools in the pipeline.

### **Impact and Sustainability of Partnership and Pipelines**

Strategic attempts to enlarge the funnel of interested and prepared students has the obvious impact; if successful these students enlarge the pipeline of students able to pursue STEM studies at the middle, high school, and university levels. At worst, the result is a more technologically literate group of students and more technologically literate teachers. Of particular note is that JCPS has made national news with its school desegregation plans and its commitment to maintain diverse populations at its schools. All of the schools in this pipeline have diverse populations ranging from 24-50% minority and 40-50% female. Minority and female students are particularly encouraged to participate in the EiE and IME programs.

This pipeline system model is sustainable specifically because of the partners: a department from an engineering school with a strategic mission of elementary and middle school outreach, a large, diverse county school system, a cadre of elementary and middle school science teachers who are committed to STEM initiatives, and the Louisville Science Center, whose strategic mission includes education and training in science, math, and technology, and industry partners. The partners have experience working together on other initiatives and have a common interest in STEM. Working together, these entities can effect change that would be difficult to accomplish by any one of the partners working separately. Moving successful programs to self-sustaining programs remains a challenge. The programs enjoy the high level of commitment and support from the Outreach Director, engineering students, and alumni.

By combining the enthusiasm and engagement of the teachers and principal from one very successful EiE program with the commitment of an engineering college, this partnership was forged and the pipeline concept created and implemented. Table 2 shows the program growth over the past four years. This fall, there are nine very active IME programs, five large EiE programs, with two schools adopting EiE for all students in grades K-5, and four schools inactive this fall, but starting back with programs in the spring. With one pipeline firmly in place, we have some confidence that the concept is successful and will eventually produce students who pursue and successfully complete a STEM degree in college. The following evidence, though not formal assessment, is encouraging:

- Teachers from programs in both elementary and middle schools report that students recognize that science and math are used to solve problems and that the EiE and IME programs have helped students to improve their problem solving skills.
- In fall 2011, 30 applicants to one middle school specifically stated that their selections were made *because of the IME program* to be offered.
- One principal attributes improved middle school science scores this past year at least partly to the IME program.
- 35 students from one middle school IME program applied to the PLTW high school, a huge increase.
- More qualified students are progressing from targeted middle schools to the PLTW high school.
- The PLTW High School Summer Engineering Camp now targets the best middle school students participating in IME. Previously leaders struggled to find enough students to attend the camp, but now it is by competitive admission.



- Two more pipelines are being created and populated, with termination points two newly designated engineering magnet high schools.

**Future Directions**

The program participation increases and the evidence of the pipeline becoming populated by showing an increase in PLTW enrollment are encouraging. The assessment data from the EiE program indicates concrete gains by students in science knowledge. However, a formal overall assessment plan is needed that tracks students through the pipeline and measures the impact on their education. Will more students study STEM fields, specifically engineering as a result of these programs? Also needed is a plan to turn successful programs into self-sustaining programs. The ability to sustain and replicate successful programs so that other elementary-middle-high-university pipelines can be created locally and elsewhere is critical for success of the pipeline concept model.

**Table 2. Program Participation: Engineering is Elementary (EiE) and In the Middle of Engineering (IME)**

<b>Program</b>	<b>Total Students Participating</b>	<b>Number of Female Students</b>	<b>Number of Male Students</b>	<b>Number of Minority Students</b>
<b>2008-2009 School Year</b>				
<b>(EiE)</b>	157	54	103	44
<b>(IME)</b>	224	93	131	121
<b>2009-2010 School Year</b>				
<b>(EiE)</b>	186	78	108	70
<b>(IME)</b>	238	95	143	86
<b>2010-2011 School Year</b>				
<b>(EiE)</b>	250	112	138	85
<b>(IME)</b>	191	74	117	40
<b>2011-Fall Programs</b>				
<b>(EiE)</b>	1720 students so far, with 865 of those being minority students.			
<b>(IME)</b>	198 students so far, no demographic data available at this time.			

Continued coordination with Boston Museum of Science and Louisville Science Center both for teacher training and student assessment will enable Speed and JCPS to obtain new information and additional training without draining the resources of Speed’s outreach program. In order to sustain the pipeline, especially as more students participate, Speed and JCPS must continue their dialog and support of current programs and support the teacher training. The success of these programs depends on proper training; both for those teachers already in the program and for those who wish to enter. It is this aspect that we will aggressively seek to improve and to obtain external funding in addition to alumni gifts and industry funding.

Plans to build a complete pipeline in a nearby county are progressing rapidly. A nearby county’s elementary and middle schools have committed to participate as has the county’s one high school. Funding to support the program has just recently been received from local industry and program initiation is scheduled for this fall, with the Department of Engineering Fundamental’s supervision. To date, the pipeline concept of “pulling elementary students into EiE programs then funneling them to middle schools with IME programs and then moving those students to engineering magnet or PLTW high schools has been effective and appears to be an outreach program model with tremendous potential

to increase both the quality and quantity of students selecting to study STEM fields. However, true success can only be measured when students in the pipeline:

- demonstrate learning gains in math and science on either standardized tests or middle school and high school math and science classes,
- choose math and science courses required for STEM majors in college,
- go to college and successfully complete STEM majors at rates beyond students who have not been in the pipeline.

## Bibliography

- [1] A National Science Action Plan for addressing the critical needs of the U.S. Science, Technology, Engineering, and Mathematics Education System, NSB-07-114, October, 2007 accessed on line at [http://www.nsf.gov/nsb/documents/2007/stem\\_action.pdf](http://www.nsf.gov/nsb/documents/2007/stem_action.pdf) November 2008.
- [2] Boisseau, R., "Engineering is Elementary on the Hill", *FYI: The AIP Bulletin of Science Policy News*, October 2, 2008, accessed on line at <http://www.aip.org/fyi/2008/097.html#> November 2008.
- [3] Carlson, L. and Sullivan, J., "Exploiting Design to Inspire Interest in Engineering Across the K-16 Engineering Curriculum", *International Journal of Engineering Education*, Vol. 20, No. 3, pp. 372-378, 2004.
- [4] Carson, R. and Campbell, P., "Museum of Science: Engineering is Elementary, Exploring the Impact of EiE on Participating Teachers", 6 p., September 2007, accessed on line at [http://www.mos.org/eie/pdf/research/2007\\_teacher\\_prepost.pdf](http://www.mos.org/eie/pdf/research/2007_teacher_prepost.pdf), February 2008.
- [5] Cunningham, C., "Elementary Teacher Professional Development in Engineering: Lessons Learned from Engineering is Elementary", 9p. 2005a, accessed on line at [http://www.mos.org/eie/pdf/research/engineering\\_pd.pdf](http://www.mos.org/eie/pdf/research/engineering_pd.pdf) February 2008.
- [6] Lachapelle, C. P., Cunningham, C.M., Jocz, J., Kay, A.E., Phadnis, P., Wertheimer, J., & Arteaga, R. (2011). *Engineering is Elementary: An evaluation of years 7 and 8 field testing*. Boston, MA: Museum of Science, accessed online at [http://www.mos.org/eie/pdf/research/IMD\\_Yrs\\_7-8\\_report\\_FINAL.pdf](http://www.mos.org/eie/pdf/research/IMD_Yrs_7-8_report_FINAL.pdf), September 2011.
- [7] Cunningham, C. and Hester, K., "Engineering is Elementary: An Engineering and Technology Curriculum for Children", *Proceedings of the 2007 ASEE Annual Conference and Exposition*, 17p., March 7, 2007.
- [8] Cunningham, C., Lachapelle, C., and Lindgren-Streicher, "Assessing Elementary School Students' Conceptions of Engineering and Technology", *Proceedings of the 2005 ASEE Annual Conference and Exposition*, 10p., 2005, accessed online at [http://asee.org/acPapers/2005-2122\\_Final.pdf](http://asee.org/acPapers/2005-2122_Final.pdf), February 2008.
- [9] Douglas, J., Iversen, E., and Kalyandurg, C., "Engineering in the K-12 Classroom, An Analysis of Current Practices and Guidelines for the Future", A Production of the ASEE EngineeringK12 Center, 22p., Nov. 2004. accessed online at [http://www.engineeringk12.org/educators/taking\\_a\\_closer\\_look/documents/Engineering\\_in\\_the\\_K-12\\_Classroom.pdf](http://www.engineeringk12.org/educators/taking_a_closer_look/documents/Engineering_in_the_K-12_Classroom.pdf), February 2008.
- [10] Jeffers, Andrew T., Safferman, Angela G., Safferman, and Steven I., "Understanding K-12 Engineering Outreach Programs," *Journal of Professional Issues in Engineering Education & Practice*, Vol. 130 Issue 2, pp. 95-108, Apr 2004.
- [11] Kentucky Council on Postsecondary Education STEM Task Force Report 2008, accessed on line at [http://cpe.ky.gov/news/reports/cpe\\_reports/stem.htm](http://cpe.ky.gov/news/reports/cpe_reports/stem.htm) February 2008.
- [12] Knight, M. and Cunningham, C., "Draw an Engineer Test (DAET): Development of a Tool to Investigate Students' Ideas about Engineers and Engineering", *Proceedings of the 2004 ASEE Annual Conference and Exposition*, 11p., Session 2530, 2004 accessed on line at [http://asee.org/acPapers/2004-1188\\_Final.pdf](http://asee.org/acPapers/2004-1188_Final.pdf) February 2008.
- [13] Lachapelle, C., "Engineering Our Future New Jersey: Evaluation of the Implementation of Elementary Curricula", 32 p., February 2007, accessed on line at [http://www.mos.org/eie/pdf/research/eie\\_nj\\_evaluation.pdf](http://www.mos.org/eie/pdf/research/eie_nj_evaluation.pdf), February 2008.
- [14] Lachapelle, C. and Cunningham, C., "Engineering is Elementary: Children's Changing Understandings of Science and Engineering", *Proceedings of the 2007 ASEE Annual Conference and Exposition*, 33p., March 7, 2007.
- [15] Moving Forward to Improve Engineering Education, National Science Foundation National Science Board 2007, 9 p. accessed on line at [www.nsf.gov/pubs/2007/nsb07122/nsb07122.pdf](http://www.nsf.gov/pubs/2007/nsb07122/nsb07122.pdf), February 2008.
- [16] Poole, S., deGrazia, J., and Sullivan, J., "Assessing K-12 Pre-engineering Outreach Programs", *Journal of Engineering Education*, 9p., Jan. 2001.
- [17] President's American Competitiveness Initiative for Education, 2007 accessed on line at <http://www.ed.gov/about/inits/ed/competitiveness/acc-mathscience/report.pdf>, February 2008.

- [18] Project Kaleidoscope Report on Reports II: Recommendations for Urgent Action 2006, accessed on line at <http://www.pkal.org/documents/ReportOnReportsII.cfm> November 2008.
- [19] Rising Above the Gathering Storm: Energizing and Employing America for a Brighter Economic Future, Report to Committee on Science, US House of Representatives, (2005) [http://www7.nationalacademies.org/ocga/testimony/gathering\\_storm\\_energizing\\_and\\_employing\\_america2.asp](http://www7.nationalacademies.org/ocga/testimony/gathering_storm_energizing_and_employing_america2.asp), accessed September 2011.
- [20] Rogers, C. and Portsmore, M., "Bringing Engineering to Elementary School", *Journal of STEM Education: Innovations and Research*, Vol. 5, no.3/4, pp. 17-28, Jul-Dec 2004.
- [21] Shields, C., "Engineering our Future New Jersey Elementary School", Proceedings of the 2006 Mid-Atlantic Section Conference of ASEE, 5p, 2006, accessed on line at [http://www.ciese.org/papers/2006/ASEE\\_paper\\_G.doc](http://www.ciese.org/papers/2006/ASEE_paper_G.doc), February 2008.
- [22] Sullivan, J., Davis, S., deGrazia, J., and Carolson, D., "Beyond the Pipeline: Building a K-12 Engineering Outreach Program", *Proceedings of the 29<sup>th</sup> ASEE/IEEE Frontiers in Education Conference*, 11b5-21-26, San Juan, Puerto Rico, Nov. 1999.
- [23] Rising Above the Gathering Storm: Two Years Later, "ISBN: 0-309-12872-2, 24 pages, (2009)," accessed online at <http://www.nap.edu/catalog/12537.html>, September 2011.
- [24] Rising Above the Gathering Storm, Revisited: Rapidly Approaching Category 5, (2010) National Academy of Sciences (NAS) accessed online at [http://www.nap.edu/openbook.php?record\\_id=12999&page=28](http://www.nap.edu/openbook.php?record_id=12999&page=28), September 2011.
- [25] Linda Katehi, Greg Pearson, and Michael Feder, Editors; Committee on K-12 Engineering Education; National Academy of Engineering and National Research Council; Engineering in K-12 Education: Understanding the Status and Improving the Prospects (2009) [http://www.nap.edu/catalog.php?record\\_id=12635](http://www.nap.edu/catalog.php?record_id=12635), accessed online September 2011.
- [26] Thomas, Charlotte, "Put the E in STEM", SWE Magazine, pp.36-40, Fall 2011.
- [27] Kressly, Rich, "Portable Inspiration: The Necessity of STEM Outreach Investment", *The Technology Teacher*, April 2009, pp. 26-29.
- [28] Yilmaz, M., Ren, J., Custer, S., and Coleman, J., "Hands-On Summer Camp to Attract K-12 Students to Engineering Fields", *IEEE Transactions on Education*, Vol 53, No. 1, pp. 144-151, February, 2010.
- [29] Brophy, S., Klein, S, Portsmore, M., and Rogers, C., "Advancing Engineering Education in P-12 Classrooms", *Journal of Engineering Education*, July 2008, pp. 369-387.
- [30] Fantz, T., Siller, T., and Demiranda, M., "Pre-Collegiate Factors Influencing the Self-Efficacy of Engineering Students", *Journal of Engineering Education*, Vol. 100, No. 3, July 2011, pp.604-623.

**Some Design & Validation Experiences of an Interactive Multimedia Resource Library for Teaching & Learning About Sustainable Green Engineering**

Paul G. Ranky, PhD

Full Tenured Professor, Registered and Chart. Professional Engineer,  
Department of Mechanical and Industrial Engineering,  
NCE, and the NJIT IT / IS Program, NJIT, Newark, NJ 07102

Email: [ranky@njit.edu](mailto:ranky@njit.edu)

PAUL G. RANKY

Paul G. Ranky, PhD Full Tenured Professor, The Department of Mechanical and Industrial Engineering, and the IT /IS Program, New Jersey Institute of Technology, NJ, USA. For a biographical sketch, including current projects and recent publications, many on-line, please visit: <http://www.cimwareukandusa.com/aboutpgr.htm>

# **Some Design & Validation Experiences of an Interactive Multimedia Resource Library for Teaching & Learning About Sustainable Green Engineering**

by

Paul G. Ranky, PhD

Full Tenured Professor, Registered and Chart. Professional Engineer,  
Department of Mechanical and Industrial Engineering,  
NCE, and the NJIT IT / IS Program, NJIT, Newark, NJ 07102

Email: [ranky@njit.edu](mailto:ranky@njit.edu)

## **Abstract**

In this paper, some design, implementation and validation experiences are discussed of an interactive multimedia resource library with particular interest towards teaching and learning about Sustainable Lean & Green Engineering, at undergraduate, as well as graduate engineering levels.

The design process of the Library started in 1985 with interactive multimedia, simulated 3D eBooks, combined with text, images, videos, spreadsheets and other active code for calculations, 360 degree panoramas, object movies, and full length interactive videos for undergraduate, as well as graduate engineering education. Since then, to date, over 25,000 student developed assignments (use cases) have been graded by the author and posted onto the web by his students as part of their course work.

In terms of our basic development and delivery methods, we deploy web-browser readable multimedia, text, images, interactive videos, 2D and simulated 3D animations, active code for calculations, simulation programs, and even self-assessment tools.

The presented approach and implemented / tested methods encourage analytical and team-oriented learning and problem-solving with real-world challenges. Using our methods, tools and technologies students perform significantly better and achieve significantly more, than with traditional teaching / learning methods.

In this paper we introduce the principles of our Library development methods and some recent solutions, and explain and demonstrate (during the live presentation) a series of case-based learning modules for undergraduate and graduate industrial engineering, engineering quality management, project management, concurrent / simultaneous green product / process design, visual lean factory management, and continuous professional education.

## **Introduction**

Millennial generation students are interested in an integrated, simultaneously analytical, computational, interactive, as well as practical, real-world-focused, customized education. They expect a large number of choices, because they understand the power of simulation. They are very visually focused, because this is the video gaming generation. They want personalized, customized products, processes and service, and their education process is not an exception. They look for technical details, and want to see it all; immediately, and virtually... They look for good quality and low cost and ease of use, and interactivity, because there is NO time to read traditional manuals and static textbooks...

They like to continuously explore, browse the web, watch interactive, rather than linear videos, explore multimedia-based publications, versus static textbooks, and always experiment, rather than follow the traditional path. They also have less need and desire to conform. They expect instant gratification. They are often impatient, and therefore want it immediately...

The benefits of introducing problems for students to solve using cases in a browser-readable 3DVR (3D Virtual Reality) interactive multimedia format are manifold. The entire learning process becomes more student- versus lecture- or tutor-centered. Students can learn by exploring versus being told, and can have as many goes at solving a problem, or exploring an idea, taking as much time as desired or is available.

Mistakes made can be corrected without penalties. Multimedia tools, and a variety of web-compatible, interactive 3D media, are available during the learning process. Within our cases self-assessment is possible. This means that students become more self-critical as they participate directly in their own learning process. Team, group and class assessment is integrated into every module of our programs (supported by active code spreadsheets, computer programs, often with embedded 3D objects, video-clips and animations) that the students can interrogate to understand either the question(s) or the answers better.

The important observation about millennial generation students is that all of the noted attributes should be respected, and that the education system should adjust to delivering these customer expectations at a high quality level. In this paper some tested pedagogical as well as advanced educational technology methods and tools are discussed, and demonstrated to satisfy the above requirements for both live and eLearning / distance learning (DL) classes.

The objective of our case-based multimedia research, that the author has started over 25 years ago, was to create a case-based / problem-based teaching and learning curriculum for Millennial generation engineering and IT students. In order to satisfy the need of an integrated, simultaneously analytical, computational, interactive, as well as practical, real-world-focused, customized education, we have developed an advanced 3D web-enabled active-code case library,

supported by on-line features, DVD full-screen, as well as HD videos, and even by smaller-size video iPod videos.

Our solution enables students to explore and analyze real-world processes, requirements, risks, 3D simulation, statistical analysis and design of experiment cases, following an analytical, 3D interactive multimedia approach. We demonstrate our method as applied to industrial engineering science, engineering management, design and manufacturing engineering, quality control, biomedical engineering, computer systems, networking subjects, and others, with the aid of a generic architecture. In terms of our basic methods, we deploy web-browser readable multimedia, text, images, interactive videos, 2D and 3D animations, active code for calculations, simulation programs, and even self-assessment tools.

Our educational and computational methods introduce a novel approach to developing and running undergraduate and graduate courses for face-to-face, hybrid (or blended), on-site professional, and distance learning (i.e. eLearning) modes.

In this paper we introduce the principles of our educational methods and some recent solutions, and explain and demonstrate (during our live presentation) a series of case-based learning modules (using interactive 3D eBooks, supported by DVD and HD videos) that encourage analytical and team-oriented learning and problem-solving with real-world challenges. (At the time of writing, our library has over twenty 3D eBooks, and over 150 full screen DVD and HD videos covering US and international virtual factory tours, research cases and in-depth product, process, service system demonstrations by field experts and other professionals; please see some real world examples to illustrate this point at <http://www.cimwareukandusa.com>)

Our efforts are supported by over 250 academic and industrial partners world-wide, assuring the diversity, the relevance and the quality of this rapidly growing library and teaching / learning method.

### **Millennial Generation Engineering Student Requirements Analysis**

Millennial generation students in the USA, Europe, Japan, and around the globe are interested in an integrated, simultaneously analytical, computational, interactive, as well as practical, real-world-focused, customized education. They expect continuous excitement, and challenging, real-world, practical examples that help them to learn analytical concepts. (The important observation here is, that major industrial leaders, such as the presidents of GM, BMW, GE, Toyota and others also want to employ young engineers, that demonstrate such qualities!)

Millennial generation students and young engineers are used to dealing with a large number of choices, because they understand the power of 3D interactive simulation. They are very visually (simulation) focused, because this is the video gaming generation. They want personalized, customized products, processes and service, and their education process is not an exception. They look for technical details, and want to see it all; immediately, and virtually...

They look for good quality and low cost, ease of use, because there is NO time to read traditional manuals and static textbooks... They like to continuously explore, experiment, get involved and experiment first hand (as the Japanese say, follow 'genchi-gembutsu' principles), rather than follow the traditional path. They also have less need and desire to conform, expect instant gratification. They are often impatient, and therefore want it immediately...

The important observation here is that all of these attributes should be respected, and that the education system should adjust to delivering these customer expectations at a high quality level. Based on 15+ years of continuous development, field testing, and over 12000 undergraduate and graduate assignments submitted, our advanced content library and tested pedagogical methods and tools satisfy the above requirements.

In this paper we focus on our generic methodology, and illustrate some engineering applications ([1], [2] and [12]). As a generic, object-oriented engineering management problem solving method, as with all cases in our library of cases, we are committed to the following approach:

- Analyze the needs and the requirements, the demonstrated processes, methods and systems they try to, or have to satisfy.
- Analyze the actual methods presented. Find the core methodologies, the mathematical models, the underlying engineering (and/or other) science foundation.



- Analyze the technologies involved. (How is science turned into a practical solution/ engineering and/or computing technology?)
- Analyze and review the actual processes and the way the process flow is integrated. (Follow an object-oriented process analysis method, e.g. from concept to product.)
- Analyze potential alternative solutions based on accurate data.
- Analyze the benefits and the disadvantages of each process/ solution.
- Design alternative methods, processes based on what you have experienced/ seen, and learned.
- Design an integrated system, based on what you have analyzed in this case. (Preferably use web-based, open source tools and knowledge documentation systems, because this will encourage every member of the team to participate, as well develop the methods further, so that they become dynamic, 'living documents'.)
- Work in a multi-disciplinary team and exchange ideas, because this way the engineering management team will become stronger, and their decisions better.
- Understand the boundaries as well as the tremendous potential of new ideas and developments by working on this case. (Realize that in order to survive and win, you must add value.)

The above challenges are presented to students using 3D interactive virtual environments of real-world challenges (see Figures 1 and 2). (Note, that the virtual approach here helps to bring students to advanced, industrial and research facilities, that would otherwise be impossible to reach, due to cost, time and other constraints.)

Furthermore, the expert guided in-depth discussions, the interactive tours, the text and other 2D and 3D media, the DVD and iPod videos, the worked out case-examples, as well as the active code in our cases offered help students to grasp the method, and then use the active code for calculating with their own data; please see some real world examples to illustrate this point at <http://www.cimwareukandusa.com>).

It is important to mention here, that the 2011 ESI Learning Trends Report ([www.esi-intl.com](http://www.esi-intl.com)) emphasizes very similar teaching / learning needs. As the report states: *'According to The Economist, if the 1990s was the age of abundance, then the 2010s may well be the age of scarcity. In both the private and public arena, the order of the day is trimming waste, tightening budgets and identifying efficiencies to 'do more with less.' In this lean environment, how do leaders responsible for learning programs adjust and adapt their human capital initiatives?*

*To assess the direction of training and performance improvement programs for 2011 and beyond, ESI International conducted a global learning survey directed at a cross-section of commercial and government leaders. They have focused on the overall learning trends, and the lean workforce in the USA.*

*ESI's findings confirm that three years of global economic stress have pushed organizations to maximize the productivity of their employees and, as budgets tighten, to make strategic decisions on trimming spending in a way that does not compromise future growth.*

*According to respondents, the recession has forever changed the makeup of their employee base. Commercial and government organizations now operate with a lean workforce, where employees, regardless of level, must have the capability to lead and execute work across cross-functional teams.*

*Top performing organizations have identified their workforce as the primary investment that can produce a greater return and higher quality output, even as overall resources and spending are reduced. To invest in their people, companies are focusing their training dollars on programs that produce measurable results and lead to demonstrated business improvement.*

*In order to maintain a competitive edge, best-in-class organizations are adopting new approaches to learning. These businesses expect to continue their investments in innovative, multi-modal learning, but will also devote further resources towards the development of leadership skills and business capabilities within communities of technical professionals.*

*Leading organizations are also adapting their learning programs to capitalize on advances in technology, including just-in-time learning applications that can keep pace with an evolving workforce demographic, which includes tech-savvy younger entrants.*

*Recognizing that training and development budgets are under strain and scrutiny, survey results validate that innovation and flexibility in learning content and delivery, coupled with a results-orientated approach, are critical components for effective 2011- 2012 learning initiatives.*

*The Learning Trends survey results confirm the changing requirements of successful performance improvement initiatives, as respondents noted the following priorities for the achievement of positive learning outcomes.*

- *Overall and overwhelmingly, organizations report that innovative learning solutions (70 percent) are needed to accomplish their business objectives.*
- *Regarding professional development solutions, the majority of organizations report that their learning programs must evolve and support a variety of learning modalities (71 percent) and be delivered through blended solutions (57 percent).*
- *Respondents expect to see tangible results from their training investment. Sixty percent report that the organizational priority to measure the business impact of learning will increase, while over half (52 percent) confirm the requirement to develop effective business cases for learning investments.*
- *When asked where they expect to see the greatest business impact of their learning investment, the majority of respondents (64 percent) expect that training dollars and outcomes will translate into increased workforce productivity.*
- *Fifty-three percent of organizations indicate that fostering and encouraging leadership skills in employees is an important area of training investment, coupled with a strong requirement to allocate funds to building business skills/acumen (40 percent) for technical professionals.*

- Nearly half of respondents (49 percent) reported that total learning and development budgets are expected to remain the same in 2011, while a smaller segment plans to increase its learning and development budgets (12.5 percent).

*Key Strategies for Shaping Tomorrow's Workforce*

*Based on ESI's experience, client engagements and further validation through survey results, organizations should enact three main strategies to boost workforce productivity, offset strained resources and prepare employees, at all levels, to be effective across the project or program life cycle.*

**1. LEARNING PROGRAMS MUST BE MORE RESULTS-ORIENTED**

*Organizations require that learning translate into tangible and measurable business impact. The ability to transfer learning in the classroom to changed performance in the workplace is essential in the achievement of enhanced productivity. Organizations must develop a supportive and complementary on-the-job environment, where management, business processes and supporting tools all permit the learner to apply new knowledge and skills immediately upon return to work.*

**Case in Point: Measuring Business Impact**

*A large investment and insurance company wanted to develop a program that would result in "High Performing Teams." It was essential that any further training would demonstrate a return on investment and tangible evidence of a positive impact back in the workplace.*

*The client's use of a systematic approach to measure the job impact of learning programs provided the statistical evidence needed to show the management team that the students who had undertaken learning not only learned new skills, but they could also quantify the exact areas where they expected to see a performance improvement.*

*To support learning transfer, training programs should be comprised of action learning events, or 'learning by doing.' Action learning closes the gap between the experience an individual has in a learning environment and their ability to transfer the learning to their work environment.*

*Learning modalities (instructor-led, e-training, virtual, peer-to-peer, mentoring, social media, etc.) will be required to support business outcomes and develop the skills and behaviors needed on the job across a diverse workforce demographic. In this manner, the learning event will transition from theory to experiential learning, with employees working on real deliverables in the classroom.*

*Further, organizations are demanding quantitative measurement tools to track business impact, and support the business case for continued learning investments, especially with budgets under scrutiny.*

**2. LEARNING METHODS MUST BE MORE FLEXIBLE AND CONTENT MORE RELEVANT**

*In today's economy, survey respondents are increasingly focused on maximizing their training investments and seeking options that minimize down time, acknowledge different learning styles, and can be customized to meet specific business needs without sacrificing quality.*

*To achieve flexible and relevant content, respondents are deploying blended learning solutions that mix assets, expand beyond the classroom and deliver content when and where needed to*

*compensate for limited training funds and the need to maximize a learner's time on the job.*

*Blended learning is a customized approach to addressing individual organizational priorities, combining a range of delivery modalities at all stages of the learning program. Just-in-time tools, learning-on-demand and self-paced online learning are just some methods that organizations are utilizing to ensure learning events are relevant and providing the right information at the point of need to enable an employee to perform effectively.*

*For best-in-class organizations, the blending of learning solutions is not simply offering a choice of modalities, but also takes into account content, learning styles, teaching techniques and learning environments, and aligns to specific learning objectives.*

*Therefore, a multi-touch, blended learning program must:*

- Support the learner's ability to recall and repeatedly apply the content in their work environment.*
- Reflect and be tailored to support organizational methodologies, culture and technical readiness in order to assure an engaged and productive workforce.*

***Case in Point: Blended Learning***

*A U.S. Government agency developed an integrated approach to contracting training using a combination of web-based training, classroom instruction and practical exercises. In order to engage students across offices, generations and work groups, the agency developed a blended learning solution, with 35% of the program deployed through web-based learning and 65% through instructor-led classroom sessions.*

*The modularized approach provided a rich, self-paced learning experience through interactive, engaging training events geared towards an individual's needs. Hosting a facilitated session after the self-paced learning was complete, allowed the content to be further reinforced through practice and application.*

**3. AN EMPHASIS ON LEADERSHIP SKILL DEVELOPMENT MUST INCREASE**

*To support global workforce productivity and agility, organizations report the increasing need to develop leadership capabilities in their employees and cite a growing priority to improve skills in stakeholder management, interactive communication and effectiveness in a cross-functional team environment.*

*Leadership is the human factor that binds a group together and motivates others in the achievement of objectives, but in a program environment, high-performing teams are distinguished by their ability to influence, persuade, challenge and communicate difficult issues.*

*Organizations must:*

- Equip the workforce with skills in critical thinking and business acumen to identify organizational priorities and design the appropriate responses within a business context.*
- Support a culture of individual accountability to speed decision-making, ensure successful project outcomes and ultimately, to assure organizational effectiveness.*
- Rapidly develop the capabilities of less tenured employees so they may manage and lead successfully to ensure continuity and productivity.*
- Achieve a new level of team dynamics to create more integration and cohesion on projects and programs, resulting in greater workforce productivity.*

*The ESI Learning Trends survey shows that while training budgets will largely be maintained, organizations are expecting more productivity from their workforce and both qualitative and quantitative measurement of the business impact from learning investments.*

*As such, training programs must evolve and adapt accordingly; they need to be targeted, relevant, measurable, and engage the learner in nontraditional ways, and at the same time instill learners with a set of critical thinking and leadership skills necessary to move the entire organization forward.*

*High-performing organizations will make smarter investments in their workforce by utilizing innovative, non-traditional learning approaches to maximize workforce productivity and adapt to today's global economic realities.'*

### **Some Architectural Design Methods and Solutions**

In this library we follow an object / component-oriented design approach, therefore the open systems architecture includes key design principles ([6] to [11]). The Case-based library programs are self contained objects built of reusable objects and components. Often, these objects and components are text, high quality images, interactive digital 2D videos, 2D and 3D animation, 3DVR (3D virtual reality) objects, animated 360 degree 3D panoramas, active code spreadsheets, simulation programs, and others; please see some real world examples to illustrate this point at <http://www.cimwareukandusa.com>).

They are open source, web-enabled, delivered on CD-ROM or DVDs, or fast university / company intranets, the new emerging opportunity for continuous professional development. The way we present challenges are similar to the way professional engineers, and engineering managers solve problems. Millennial engineering students like this approach. This is because we first look at the real-world customer requirement, then offer one or more solutions by explaining real-world machines, or processes, or systems, or management tasks and then discuss further development, service, maintenance, integration, connectivity and many other issues with several feedback loops, and then offer discussion opportunities for real or virtual teams.

In all cases the library modules show high quality, interactive videos and often 3D objects and 360 degree interactive panoramas so that learners can interrogate objects, take products virtually apart in 3D, enjoy virtual factory or facility tours and even participate/ collaborate actively by e-mail and other Internet methods.

In terms of challenging the learner to learn and investigate the illustrated case(s) further the cases give them several direct URL (web) contacts, e-mail addresses so that they can get in touch with anybody over the web, including any of the authors who have created/presented the cases. In several cases, assessment is supported by spreadsheet-based automated tools, that in case of an incorrect answer hyper-links the learner back to a variety of revision solutions, so that the missed material can be learned, and the test re-taken.

The assessment questions address exciting engineering, management, and computing science / IT (Information Technology), biomedical engineering, and other issues, and in many cases document best practices. This approach helps distance learners as well as educators to work with the material in real-world classroom and/or virtually web-networked teams.

**The cases are object-oriented and self-contained, nevertheless can be integrated/ grouped into different classes of objects in a lean and flexible way (the same way as a modern software program, or a modern manufacturing / assembly system can be integrated into different environments). This enables learners as well as tutors and managers to 'plug-and-play' the Library cases in the way they choose to, rather than the way the author meant it. This means that our 'typical' readers are problem solvers, as well as readers and authors at the same time... an interesting challenge for all of us.**

The ways we present challenges are very similar to the way professional engineers solve problems. Notice that we do not follow the traditional linear, but rather the modern concurrent, object oriented approach to integrated product/ process design ([7], and [8] and [11] to [13]). The methodology we follow enables basic knowledge transfer enabled with interactive multimedia. It is highly interactive, collaborative and enables large groups as well as individuals to gain the same knowledge effectively ([1]).

Although this method is not for everybody because the problems as well as the solutions are interdisciplinary, often open-ended and can get complex, in all cases our solution will enhance, support and enable a wide range of interactions with real-world challenges ([11] to [15]) and please see some real world examples to illustrate this point at <http://www.cimwareukandusa.com>.

The benefits of introducing problems for students to solve using cases in a browser-readable 3DVR interactive multimedia format are manifold. The entire learning process becomes more student- versus lecture- or tutor-centered. Students can learn by exploring versus being told, and can have as many goes at solving a problem, or exploring an idea, taking as much time as desired or is available. Mistakes made can be corrected without penalties. Multimedia tools, or a subset of such technology and a variety of media, are available during the learning process.

Within our cases self-assessment is possible. This means that students become more self-critical as they participate directly in their own learning process. Team, group and class assessment is integrated into every module of our programs (supported by active code spreadsheets, often with embedded 3D objects, video-clips and animations) that the students can interrogate to understand either the question(s) or the answers better. Furthermore, in our assessment programs graphs are shown illustrating individual vs. group/class benchmark assessment results. This is very useful, in particular for distance learning students, because they feel that they are equal members of the class. (Traditional,

as well as e-mail, web-collaborative, telephone and personal-appointment-based tutorial support is available if required.) As a result, the entire education process is more suited to satisfy individual needs from 'batch size 1 to many' at the same high quality ([14] and [15]).

The most important design feature of our object oriented system architecture is that there is only one core, reusable electronic document, built of 3D web-objects, and active code, that has to be authored and maintained. This enables a wide variety of users/viewers to occasionally become authors (via the appropriate security gates and web-technology) feeding useful knowledge into the content of the object and component oriented architecture. As an example of a learning-object, in **Figure 1**, we illustrate a Component-oriented Requirements Analysis (CORA) matrix-based method, similar to QFD (Quality Function Deployment) practices, developed for user requirement / need analysis.

As can be seen in Figure 1, the team enters the

1. User requirements in the left hand side of the matrix, including their
2. Priority ratings, then the
3. Selected engineering solutions (at the top of the matrix) and then the
4. Correlation values (1, or 3, or 9) linking requirements and engineering solutions in the actual matrix (middle section of the spreadsheet).

It should be noted, that we enter data into a CORA spreadsheet on a relative scale, therefore standards should be determined by the local CORA Team, as well as by the local, customized standards they follow. As a result of our team efforts, the CORA software tool calculates absolute and relative importance ratings, and guides the team on where to put critical resources for improving customer satisfaction, quality, and others. (Note, that some of these cells link to various additional 3D interactive multimedia, or active code. Please visit <http://www.cimwareukandusa.com>, to review more examples.)

**Figure 2** (below) illustrates a screen segment, that enables students to actively manipulate real-world photo-realistic virtual 3D objects, and explore customer requirements following our analytical approach. (Please note, that our original screens are in high quality, full screen and full color graphics that we had to reduce in size and quality to fit the format requirements of this paper.) (Please visit <http://www.cimwareukandusa.com>, to review the above interactive 3D rapid prototyped objects in color in our library).

**Fig2\_RankyCORANetwRobotsV5.xls**

**Object / Component Oriented Requirements Analysis Program for Automotive Networked Robots** by Paul G. Ranky © 1992-2002

© Paul G. Ranky, 2000-2002  
<mailto:cinware@cinwarekandusa.com?subject=Requirements Analysis Template ver.5>

Engineering / Support Solutions  
 Respon Requirements

Automotive Line Manager:  
 Customer Requirements  
 (Reflecting component/ object  
 behavior related to customer needs)

S.No	Describe the Requirement	Importance Rating (1-5)	Fieldbus Network	Profibus Network	DeviceNet Network	Ethernet	Graphical Robot Program	On-site maint. Support	Off-site Maint. Support	On-site Redundant Se	Off-site Redundant Se	Link to Factory MRP	Link to Factory TQM	2D videos/ 3D multimedia	Cell-based web Camera	PC-based Robot Controller
1	Reliability of data transfer for real-time access should be high	5	9	9	9	9				9	9					
2	Reliability of reporting process failure to the line manager's computer	4	9	9	9	9										9
3	Ease of integration into a system (plug and play networking): important!	4	9	9	9	9										9
4	Ease of robot programming (welding/ assembly)	3				9	9	9								3
5	Ease of changing robot programs (locally, and via the network)	4	9	9	9	9	9	3	9					9	9	3
6	Ease of adding new sensors to a robot, or robot cell, or line	3	9	9	9	9										9
7	Safety of operation: critical!	5	9	9	9	9		9	3	9	3					9
8	Cost of change/ extension/ system expansion should be low	4	3	3	3	3		9	3	3	3					9
9	Operator training needs and costs should be low	3					9	9	3							9
10	Network installation complexity and cost should be low	3	9	9	9	9			3	3						9
11	Maintenance complexity and cost should be low	5	9	9	9	9				9	3					9
12	Network management responsibilities should be high	3	3	3	3	9										
13	Network reliability must be high	3	3	3	3	9										
14	The network should report robot production data	5	1	1	1	3						9				
15	The network should report robot process quality data	5											9			
16	Robot tool management should be on the network	3										3				
17	Operators should have multimedia manuals for in-process training	4	3	3	3	3	9							9	9	9
18	The network should have 'panic' support by simulating alt. solutions	4	3	3	3	3	9									9
19	The network must be linked to the factory LAN	5	9	9	9	9	9		3	3	1	9	9			9
20	The system history database should be on the network	5	3	3	3	3			3	3	9	9	9	3	3	9
<b>Target Values</b> (List here the parameters that specify engineering solutions accurately. If you don't know the range of the acceptable values, use our Target Values)			27 msec	27 msec	27 msec	27 msec	ronized, edia	an 3 s	an 24 his	switch	an 30 itch	h every 2 s	h every 2 s	40 pixels per	40 pixels per	mux, . or DSX

Sheet1 / Sheet2 / Sheet3

**Figure 1.** Sample multimedia screen for analytical calculations.



- Performance
- Reliability
- Cost
- Safety
- Developmentability (i.e. how easy is it to develop an idea, or a prototype 'product' to become a real, marketable product?)
- Serviceability / maintainability
- Simplicity (Software engineers, don't forget to include the user interfaces here!)
- Interchangeability (Everybody, note the modular, or in IT terms, the object / component - oriented aspects of your product!)
- Capacity
- Life cycle, and even more: Multi-lifecycle and environmental attributes, including ease of maintenance, demanufacturing, and disassembly
- Appearance (Industrial designers you'll like this because customers like this too; just think of a [jazzy car](#), or a [motorbike](#), and many other products!)



To summarize, **the engineering** (including software engineering and engineering management) **decision process is about:**

- Analysis
- Synthesis
- Evaluation
- Execution



When working through this case we follow the above outlined thinking process. We strongly recommend, that you always keep this well tested approach in mind.

#### Rules for Brainstorming

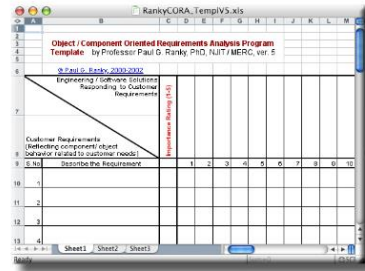
Since you'll be probably working on this case in a **small real-world, or virtual CORA team over the web**, ideally consisting of a product / process design expert, a marketing manager, a system analyst or industrial engineer, a manufacturing / assembly engineer, a quality manager, an industrial designer, a media expert and web master, and others, make sure that you understand the basics of brainstorming.



These are the well-known rules:

1. **Clarify the objectives** (in this case the objective is to find out what customers want, need, desire, and require, and then specify improved product / process design opportunities).
2. **Identify all the tasks** you have to accomplish as individuals as well as a team.
3. Put the agreed tasks into a **logical order**.
4. Estimate the **time and additional resources** you will need (e.g. web searching and research time) to accomplish the job.
5. **Allocate responsibilities within the team**.
6. **Review the entire plan, understand our approach** before you start using our CORA spreadsheet template and customize it further.

Just click on the poster below, and you'll **hyper link to the active CORA Template**, implemented in MS-Excel. Having learned our methods, you'll be able to populate this template with your own data.



In order to **trigger user requirements** and then to **identify and communicate** product / process design ideas during the brainstorming sessions, we need to see what is available in the field. (Just click on these posters to activate the **2D images** and review the huge variety of different external rearview mirror designs, that satisfy various customer groups. Need [Help?](#))



**Figure 2.** Sample 3D eBook multimedia screen with graphical, 3D interactive objects.

## Summary and Conclusions

Our 3D multimedia learning eBooks, DVD videos and active code programs have been validated and tested in several industry and university (live and virtual) classes, involving thousands of undergraduate and graduate Millennial students. The subjects include Industrial Engineering, Mechanical Engineering, Manufacturing Systems Engineering, Information Technology, Information Systems, Visual Factory Management, Total Quality Management, Product Lifecycle Management, Concurrent Engineering, Robotics, Lean Manufacturing, Warehousing and Logistics, and many others.

This work is the result of several years of on-going R&D. It started in 1977-78. Since then the topic as well as the architecture has evolved into a robust, object-oriented knowledge management architecture with 3D web-objects, DVD videos, active code programs, and others, supported by several companies and institutions. Our efforts have been validated and strongly supported most importantly by our undergraduate and graduate engineering, engineering management and computing students at NJIT, and elsewhere in the world, who have worked through different versions of our library and

helped us shaping it to its current, robust multi-platform format. Based on feedback obtained from the students surveys clearly indicated, that Millennial generation students prefer 3D interactive learning resources, rather than traditional static books. We would like to thank for their continuous support.

It is also interesting to see, that over 30 years ago, when this work started most of the 2011 ESI Learning Trends Report findings were already considered and implemented in our eBooks and the teaching / learning library...

### **Live 3D eBook and Software Demonstration**

During the presentation of this paper at the conference there will be several live demonstrations, including 3D interactive multimedia eBooks, and HD technical videos of our library. (Please see some real world examples to illustrate this point at <http://www.cimwareukandusa.com>).

### **Bibliographic Information**

[1] Ranky P G: Interactive Multimedia for Engineering Education, European Journal of Engineering Education, Vol. 21, No. 3, 1996, p. 273-293.

[2] Ranky, P G., Golgen Bengu and Gale Tenen Spak: The Development and Application of Synchronous and Asynchronous Technology Based Learning Aids for Undergraduate Engineering Education, The NSF Engineering Education Innovators' Conference, NSF sponsored participation, April 7-8, 1997, Arlington, VA, USA, Proceedings

[3] Ranky, P. G.: Some Analytical Considerations of Engineering Multimedia System Design within an Object Oriented Architecture, IJCIM (International Journal of CIM, Taylor & Francis, London, New York) ), Vol. 13, No. 2, May 2000, p. 204-214

[4] Ranky, P G, Caudill, R. J., Limaye K., Alli, N., Satishkumar ChamyVelumani, Apoorva Bhatia and Manasi Lonkar A Web-enabled Virtual Disassembly Manager (web-VDM) for Electronic Product / Process Designers, Disassembly Line Managers and Operators, a UML (Unified Modeling Language) Model of our Generic Digital Factory, and Some of Our Electronic Support System Analysis Tools, ADAM with IT (Advanced Design And Manufacturing), An international internet registered R&D journal hosted by: <http://www.cimwareukandusa.com> listed and indexed by the Association of Research Libraries, Washington DC, USA, and the Edinburgh Engineering Virtual Library, UK. USA, 5 p., Vol. 3., May 2002

[5] Ranky, P G, Herli Surjanhata, One-Jang Jeng, Geraldine Milano: The Design and Implementation of Digital Educational Knowledge Assets (DEKA) with Software Demonstration (An NJIT and Industry Sponsored R&D Project. ASEE (American Society of Engineering Education) NJ Spring Conference, April, 2001 (eProceedings)

[6] Ranky, P G, Ranky M F, Flaherty, M, Sands, S and Stratful, S: Servo Pneumatic Positioning, An Interactive Multimedia Presentation on CD-ROM (650 Mbytes, 330

interactive screens, 70 minutes of digital videos, animation and over 300 photos), published by CIMware (IEE and IMechE Approved Professional Developer), March 1996. Multimedia design & programming by P G Ranky and M F Ranky.

[7] Ranky, P.G.: A 3D Multimedia Case: Component Oriented Disassembly Failure Risk Analysis, An interactive multimedia publication with 3D objects, text and videos in a browser readable format on CD-ROM/ intranet by <http://www.cimwareukandusa.com>, CIMware USA, Inc. and CIMware Ltd., UK, ISBN 1-872631-47-9, 2001-2007. Multimedia design & programming by P G Ranky and M F Ranky. (Published 6 volumes of this main title with different risk analysis challenges explained).

[8] Ranky, P.G.: A 3D Multimedia Case: Component Oriented Disassembly User Requirements Analysis, An interactive multimedia eBook publication with 3D objects, text and videos in a browser readable format on CD-ROM/ intranet by <http://www.cimwareukandusa.com>, CIMware USA, Inc. and CIMware Ltd., UK, ISBN 1-872631-50-9, 2001-2007. Multimedia design & programming by P G Ranky and M F Ranky. (Published 7 volumes of this main title with different requirements analysis challenges explained).

[9] Nadler .S. F., Ranky, P.G and Ranky, M.: A 3D Multimedia Approach to the Diagnosis of Low Back Pain (Vol. 1 18 & 40 year old males), An Interactive 3D Multimedia Presentation on CD-ROM with off-line Internet support (650 Mbytes, approx. 150 interactive screens, 50 minutes of digital videos, 3D internal and external body tour, animation and 3DVR objects), by CIMware ISBN 1-872-631-63-0, 2002-2006, Multimedia design & Programming by P G Ranky and M F Ranky.

[10] Roman, H.T. and Ranky, P.G.: A Case-based Introduction to Service Robotics; An interactive multimedia eBook publication with 3D objects, text and videos in a browser readable format on CD-ROM/ intranet by <http://www.cimwareukandusa.com>, CIMware USA, Inc. and CIMware Ltd., UK, ISBN 1-872631-48-7, 2003-2007. Multimedia design & programming by P G Ranky and M F Ranky.

[11] Ranky, P.G.: An Introduction to Digital Factory & Digital Telematic Car Modeling with R&D and Industrial Case Studies; An interactive multimedia eBook publication with 3D objects, text and videos in a browser readable format on CD-ROM/ intranet by <http://www.cimwareukandusa.com>, CIMware USA, Inc. and CIMware Ltd., UK, ISBN 1-872631-66-5, 2003-2008.

[12] Ranky, P G: Novel Automated Inspection Methods, Tools and Technologies: Assembly Automation, An International Journal, Vol. 23, No. 3, Emerald Publishing Ltd., England, pp. 252-257.

[13] Ranky, P G: Advanced Machine Vision Systems and Application Examples: Sensor Review, An International Journal, Vol. 23, No. 3, 2003, Emerald Publishing Ltd., England, pp. 242-245.

[14] Ranky, P.G.: An Introduction to Alternative Energy Sources: Hybrid & Fuel Cell Vehicles; An interactive multimedia eBook publication with 3D objects, text and videos in a browser

readable format on CD-ROM/ intranet by <http://www.cimwareukandusa.com>, CIMware USA, Inc. and CIMware Ltd., UK, ISBN 1-872631-97-5, 2003-2008. Multimedia design & programming by P G Ranky and M F Ranky.

[15] Ranky, P.G., Ranky, G.N., Ranky, R. G.: An Integrated, Analytical Product, Process and Service System Design Innovation Method, Tools, and Examples, within a Statistical and 3D Interactive Multimedia Framework, The 2006 International Symposium on Flexible Automation (ISFA), Osaka, Japan, sponsored by NSF, IEEE Robotics and Automation Society, July 10-12, 2006

#### **Further References and Reading...**

[16] May 2008, Green Manufacturing Engineering R&D Seminars in Hong Kong, Hong Kong / China

[17] December, 2008, Sustainable Eco-friendly Green Engineering and Technology R&D Seminars in Hong Kong, China, Hong Kong Institute of Industrial Engineers, IE, CA, EV Divisions, AMC and MC co-organized technical seminar ([Summary](#))

[18] February 5, 2009, IEEE Industry Day, Sustainable Green Design and Manufacturing, Telcordia Building, Piscataway, NJ ([http://www.ewh.ieee.org/r1/princeton-centraljersey/ieee\\_industry\\_day.htm](http://www.ewh.ieee.org/r1/princeton-centraljersey/ieee_industry_day.htm))

[19] February 12, 2009, NJIT Graduate Students in Engineering Management, Total Quality Management and Green Concurrent Engineering, PLM, Stabile Lab., NJIT

[20] April 14, 2009, Sustainable Green Engineering and Quality seminar, ASQ (American Society for Quality) regional meeting at NJIT  
April 21, 2009, SAE (Society of Automotive Engineers) Green Mobility International World Congress R&D paper presentation: Sustainable Green Design And Manufacturing Requirements and Risk Analysis Within A Statistical Framework, Detroit, Michigan (In the World Congress proceedings)

[21] April 21-22, 2009, Green Supply Chain the Eyefortransport Logistics Technology Forum in Chicago, 10th North American Technology Forum

[22] April 30-May 1, 2009, New Jersey Technology Education Conference, Workshop Designed on Sustainable Green Engineering (curriculum development and research), <http://www.njtea.org/Pages/ProDev/NJTEA%20Conference.html>

[23] Ranky, P.G., and Ranky, G.N.: Wiley-Blackwell Encyclopedia of Computer Science and Engineering: Chapter on CD-ROMs and Computer Systems, by Wiley-Blackwell, USA, 5 volume set, 3328 pages total, 2009.

[24] Ranky, P.G.: A Green Product Lifecycle Management (PLM) Focused Customer Requirements Analysis Method, with Design of Experiment Principles & Tools to Assure Zero Project Failure, the IEEE Sponsored Second International Conference on Engineering Systems Management and its Applications (ICESMA2010) March, 2010, Sharjah, The

American University of Sharja, near Dubai (UAE)

[24] Ranky, P.G.: Sustainable Product and Process Engineering Management Rules and Examples, Following Monozukuri Principles, the IEEE Sponsored Second International Conference on Engineering Systems Management and its Applications (ICESMA2010) March, 2010, Sharjah, The American University of Sharja, near Dubai (UAE), also Session Chair: Green Supply Chain Management.

[25] Ranky, P.G.: An Integrated Architecture, Methods and Some Tools for Creating More Sustainable and Greener Enterprises, IEEE 2010 International Symposium on Sustainable Systems, Washington DC, USA, May 2010, In the Proceedings

[26] Ranky, P.G.: Sustainable Green Product Design and Manufacturing / Assembly Systems Engineering Principles and Rules with Examples, IEEE 2010 International Symposium on Sustainable Systems, Washington DC, USA, May 2010, In the Proceedings

[27] Ranky, P.G.: Problem-based Teaching / Learning Methods and Cases for Millennial Generation Engineering Students Interested in Sustainable Green Engineering, IEEE 2010 International Symposium on Sustainable Systems, Washington DC, USA, May 2010, In the Proceedings

[28] Ranky, P.G.: Creating More Sustainable and Greener Quality Enterprises: Methods & Technologies, ASQ (American Society for Quality), 2010 USA Symposium on Quality, New Jersey, April 2010, In the Proceedings

[29] Ranky, P.G.: Case-based / Problem-based Sustainable Green Engineering Teaching / Learning Methods and Experiences for Millennial Generation Engineering Students in the USA, Europe and Asia, ISFA2010 (International Symposium on Flexible Automation) in Tokyo, Japan, July 2010, Sponsored by NSF (USA), ASME (USA), Japan Society for Quality Engineers, and others. Paper published in the Proceedings. Also Session co-chair of the Green Engineering Session, as well as the Electric Car Design and Manufacturing Session.

[30] Ranky, P.G.: An Introduction to Sustainable Green Engineering Part 1, 2010-2011, IEEE Sustainable Green Engineering Publications, (approximately 95 interactive multimedia screens): IEEE (USA) on-line publication:  
[http://www.ieee.org/publications\\_standards/publications/subscriptions/prod/elearning\\_overview.htmlgth](http://www.ieee.org/publications_standards/publications/subscriptions/prod/elearning_overview.htmlgth)

[31] Ranky, P.G.: An Introduction to Sustainable Green Engineering Part 2, 2010-2011, IEEE Sustainable Green Engineering Publications, (approximately 90 interactive multimedia screens): IEEE (USA) on-line publication:  
[http://www.ieee.org/publications\\_standards/publications/subscriptions/prod/elearning\\_overview.htmlgth](http://www.ieee.org/publications_standards/publications/subscriptions/prod/elearning_overview.htmlgth)

[32] Ranky, P.G.: Introduction to Sustainable Green Engineering System Analysis & Design, 2010-2011, IEEE Sustainable Green Engineering Publications, (approximately 85 interactive multimedia screens): IEEE (USA) on-line publication:  
[http://www.ieee.org/publications\\_standards/publications/subscriptions/prod/elearning\\_](http://www.ieee.org/publications_standards/publications/subscriptions/prod/elearning_)

overview.htmlgth

[33] Ranky, P.G.: Sustainable Green Engineering Modeling Methods, Notations & Examples, 2010-2011, IEEE Sustainable Green Engineering Publications, (approximately 80 interactive multimedia screens): IEEE (USA) on-line publication:

[http://www.ieee.org/publications\\_standards/publications/subscriptions/prod/elearning\\_overview.htmlgth](http://www.ieee.org/publications_standards/publications/subscriptions/prod/elearning_overview.htmlgth)

[34] Ranky, P.G.: Data Dictionary and Process Description Methods & Examples, 2010-2011, IEEE Sustainable Green Engineering Publications, (approximately 70 interactive multimedia screens): IEEE (USA) on-line publication:

[http://www.ieee.org/publications\\_standards/publications/subscriptions/prod/elearning\\_overview.htmlgth](http://www.ieee.org/publications_standards/publications/subscriptions/prod/elearning_overview.htmlgth)

[35] Ranky, P.G.: Process Modeling Use Cases and More Green Engineering Challenges & Solutions, 2010-2011, IEEE Sustainable Green Engineering Publications, (approximately 90 interactive multimedia screens): IEEE (USA) on-line publication:

[http://www.ieee.org/publications\\_standards/publications/subscriptions/prod/elearning\\_overview.htmlgth](http://www.ieee.org/publications_standards/publications/subscriptions/prod/elearning_overview.htmlgth)

[36] Ranky, P.G.: Customizable and Downloadable Graphic Templates (PC and Mac) for Process Modeling Green Engineering Systems, 2010-2011, IEEE Sustainable Green Engineering Publications, (approximately 60 interactive multimedia screens): IEEE (USA) on-line publication:

[http://www.ieee.org/publications\\_standards/publications/subscriptions/prod/elearning\\_overview.htmlgth](http://www.ieee.org/publications_standards/publications/subscriptions/prod/elearning_overview.htmlgth)

[37] Ranky, P.G.: Sustainable Green Engineering and Technology, an IET Malaysia Institutional research seminar and workshop at the University of UTAR in Malaysia, July 2011.

[38] Ranky, P.G.: ISO (International Standards Organization) 50001 International Standard on Energy Management co-author. Published by ISO in June 2011 (more at <http://www.cimwareukandusa.com>)

**A New Online Laboratory-based Engineering Technology Course in Networks for the Industrial Environment**

Warren Rosen  
wrosen@ece.drexel.edu

# A New Online Laboratory-based Engineering Technology Course in Networks for the Industrial Environment

## Abstract

This paper describes the development of a new online graduate engineering technology course in advanced networks for industrial environments. The course is intended to provide an in-depth overview of high-performance wired and wireless networks for industrial control, communications, and computing. The emphasis is on understanding current and newly emerging network architectures, protocols, and technologies in terms of performance, network services, ease of implementation, maintenance, reliability, risk, and cost.

## Introduction

High-performance data networks are one of the key enabling technologies in state-of-the-art industrial settings. It is essential that anyone interested in areas such as product improvement, industrial practices, engineering technology operation, etc. have a fundamental understanding of network protocols and hardware that may be needed in this environment.

This paper describes the development of a new online graduate engineering technology course in advanced networks for industrial environments at \*\*\*\*\* University. The course is intended to provide an in-depth overview of high-performance wired and wireless networks for industrial control, communications, and computing. After completing the course students will be familiar with topics such as the OSI and TCP/IP protocol stacks and common network protocols such as Ethernet (IEEE 802.3),<sup>1</sup> Wi-Fi (IEEE 802.11<sup>2</sup>), Bluetooth,<sup>3</sup> ZigBee,<sup>4</sup> DPN3,<sup>5</sup> and CAN.<sup>6</sup> The goal is to enable students to make sensible decisions when selecting and implementing a network protocol for a particular industrial application.

## Course Content

The course syllabus is shown in Figure 2. The course begins with an introduction to what network protocols are using the example of collision detection in the context of ordinary conversation. The use of this technique in first generation Ethernet is then described. Next, the importance of layered protocols is discussed and the DARPA, OSI and TCP/IP models are discussed. Circuit and packet switching are then compared with respect to performance, ease of implementation, and cost. Statistical methods and industry-standard CAD tools used in performance modeling are then described. The introduction concludes with a discussion of physical media, including copper wire, wireless, and fiber optic cable, with an emphasis on cost-performance tradeoffs.

The next four weeks are devoted to detailed descriptions of each of the layers of the TCP/IP protocol stack. A top-down approach is used, starting with the Application and Transport layers and ending with the Physical layer. The text for the course is *Computer Networking: A Top-Down Approach*<sup>7</sup> by J.F. Kurose and K.W. Ross, early advocates of the top-down approach.

Week	Topic
1	Introduction to network protocols and technologies, network topologies, the OSI



	and TCP/IP protocol stacks, circuit and packet switching, selection criteria
2	Network performance, throughput and latency, physical media
3	Application layer
4	Transport layer
5	Network (Internet) layer
6	Network Access layer
7	Ethernet
8	Some typical industry-specific networks (CAN, DPN3, etc.)
9	Wireless network protocols
10	Network security

Figure 2. Topics covered in the 10-week course.

Following the introduction a detailed description of each of the layers of the TCP/IP protocol stack is presented. A top-down approach is used, starting with the Application and Transport layers and ending with the Physical layer. Next, a number of network protocols used in industry are described in detail, beginning with Ethernet. Ethernet is not only ubiquitous in communications systems but is also widely used in industrial control, for example, to interconnect programmable logic controllers.

Next, several industry-specific network protocols are discussed, including CAN and DPN3. CAN (Controller Area Network) is a multi-master serial bus protocol originally designed to transmit short messages between microcontrollers in an automotive environment. Since its inception in 1986, its range of applications has expanded into such areas as industrial automation and medical equipment. DPN3 (Distributed Network Protocol) is an open standard intended to provide interoperability between computers and intelligent devices in the electric utility industry. The standard provides for an IP-based serial point-to-point link.

Wireless network protocols are then discussed in some detail, including 802.11, Bluetooth, and ZigBee. Bluetooth is becoming increasingly useful in industrial applications as cable replacement, in wireless sensor networks, and as an interface to IP-based networks. ZigBee is a suite of protocols designed for low-power, low data rate RF mesh networks used to control consumer electronics, heating/cooling systems, lights, etc. It is finding increasing use in distributed control and monitoring in industrial settings.

The final topic is network security. Security is an important consideration in the industrial environment. Particular emphasis is placed on securing email, Virtual Private Networks, and security in wireless networks. The networks previously described are compared in terms of performance and security features.

To provide hands-on experience with network protocols, experiments with two industry-standard modeling and evaluation tools, OPNET's IT Guru and Wireshark, are used. OPNET is a graphical network traffic simulator used for packet-level performance analysis of metrics such as throughput and delay. To use it components such as routers, hosts, servers, etc. are dragged from various menus and then connect them up in the desired topology. Figure 3 shows a typical screenshot of a network defined in this way. It shows three hosts connected through a local 100 Mb/s Ethernet switch to a cable that provides an Internet connection through a WAN to three remote servers. OPNET provides accurate models of real commercial devices—note in the figure that the model for a real, commercially available Linksys cable modem is being used. They also have models for all

popular protocols and you can define your own devices or protocols in a high-level language such as C. You can choose the link speeds as well.

A variety of traffic patterns may be specified. For example, traffic may be generated with a random number generator using several statistical distributions such as normal or Poissonian for packet length and inter-packet time. The simulator can produce useful information such as average and instantaneous throughput, average or instantaneous delay, delay by priority, etc. Figure 4 shows the delay of individual packets as they are generated over time.

IT Guru may be freely downloaded for academic use and the students can run it on their own computers.

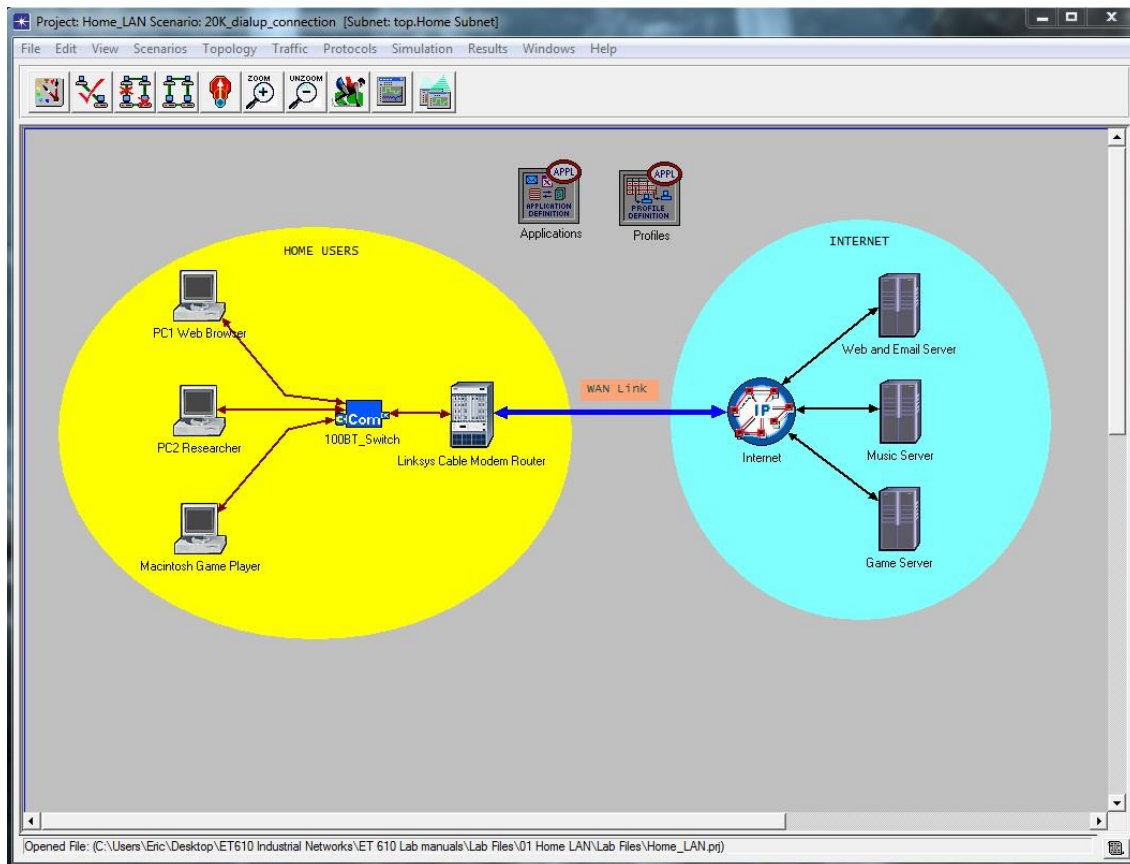


Figure 3. Typical OPNET screenshot.

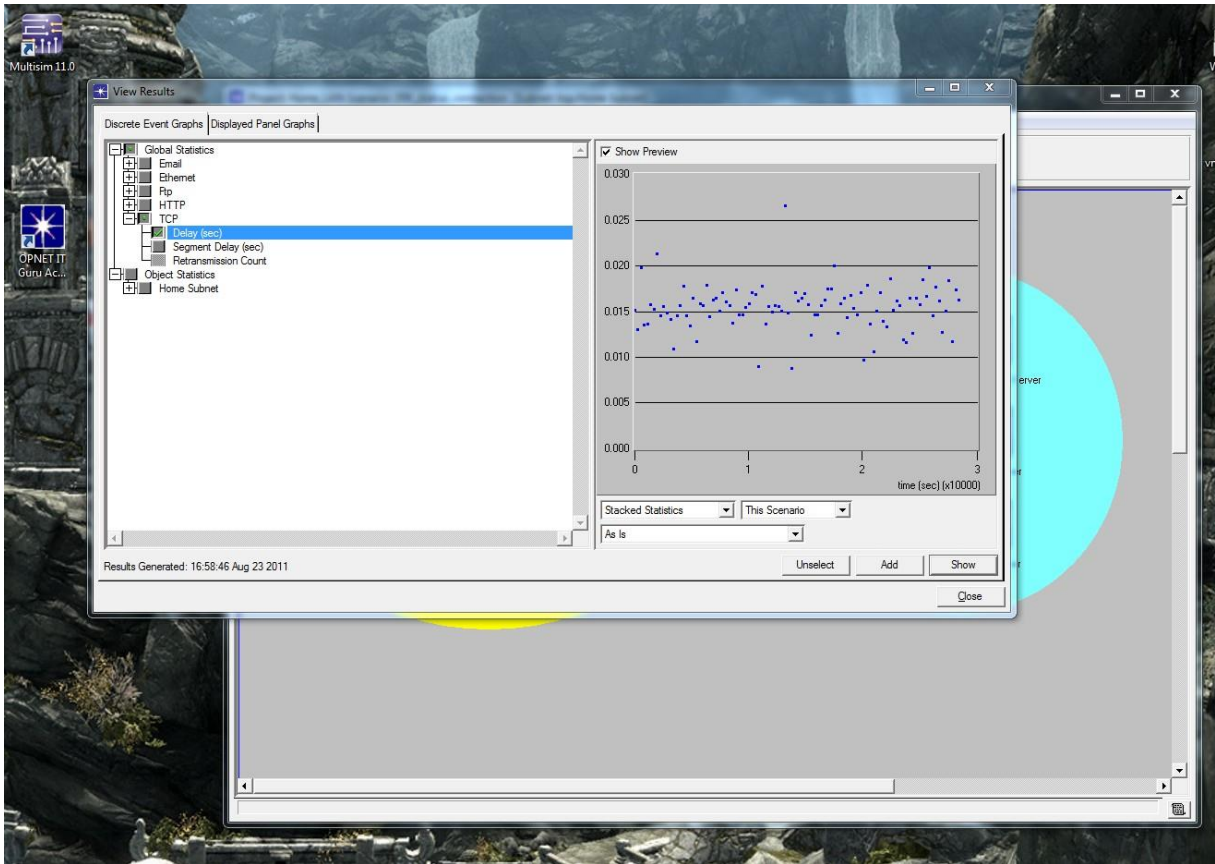


Figure 4. OPNET results showing individual packet delay over time.

Wireshark<sup>37</sup> is used to give the students hands-on experience with their own local area network. Wireshark is a GUI-based open-source protocol analyzer used for network troubleshooting and analysis. It can sniff out information such as source and destination addresses or the contents of packets at various network layers in the students' actual local network. Figure 5 shows a Wireshark screenshot showing the capture of packets corresponding to the request of a web page using the http protocol. The image shows the "Get" command, requesting the root document. The hostname is www.paleotechnologist.net.

Figure 6 shows the response from the host. It took about 300 ms for the request to go out (via a VPN connection), reach the webserver, and be processed and returned. Because Wireshark can capture a large amount of information quickly it is essential for the students to learn how to start it up, capture the needed data, and then shut it down quickly before some other process makes an Internet request. By clicking on the request, then the response, the student can see what information was exchanged.

The software may be freely downloaded by the students under the terms of the GNU General Public License, and versions are available for both PCs and Apple computers.

(Untitled) - Wireshark

File Edit View Go Capture Analyze Statistics Telephony Tools Help

Filter: http Expression... Clear Apply

No. -	Time	Source	Destination	Protocol	Info
4	0.033112	144.118.2.37	128.177.28.118	HTTP	GET / HTTP/1.1
9	0.332666	128.177.28.118	144.118.2.37	HTTP	Continuation or non-HTTP
11	0.333155	128.177.28.118	144.118.2.37	HTTP	Continuation or non-HTTP
12	0.333444	128.177.28.118	144.118.2.37	HTTP	Continuation or non-HTTP
15	0.361354	128.177.28.118	144.118.2.37	HTTP	Continuation or non-HTTP
17	0.361811	128.177.28.118	144.118.2.37	HTTP	Continuation or non-HTTP
18	0.362343	128.177.28.118	144.118.2.37	HTTP	Continuation or non-HTTP
20	0.362729	128.177.28.118	144.118.2.37	HTTP	Continuation or non-HTTP
22	0.363123	128.177.28.118	144.118.2.37	HTTP	Continuation or non-HTTP
25	0.379216	144.118.2.37	128.177.28.118	HTTP	GET /wp-content/themes/d
28	0.392008	128.177.28.118	144.118.2.37	HTTP	Continuation or non-HTTP
30	0.392498	128.177.28.118	144.118.2.37	HTTP	Continuation or non-HTTP
31	0.392787	128.177.28.118	144.118.2.37	HTTP	Continuation or non-HTTP
33	0.393197	128.177.28.118	144.118.2.37	HTTP	Continuation or non-HTTP
35	0.396869	128.177.28.118	144.118.2.37	HTTP	[TCP Previous segment lo
37	0.397254	128.177.28.118	144.118.2.37	HTTP	Continuation or non-HTTP

Frame 4 (649 bytes on wire, 649 bytes captured)

- Ethernet II, Src: Cisco\_3c:78:00 (00:05:9a:3c:78:00), Dst: PrimaryA\_6b:06:cf (00:20:9c:6b:06:cf)
- Internet Protocol, src: 144.118.2.37 (144.118.2.37), Dst: 128.177.28.118 (128.177.28.118)
- Transmission Control Protocol, Src Port: plbserve-port (3933), Dst Port: http (80), Seq: 1, Ack: 1, Len: 649
- Hypertext Transfer Protocol
  - GET / HTTP/1.1\r\n
  - Host: www.paleotechnologist.net\r\n
  - User-Agent: Mozilla/5.0 (Windows; U; Windows NT 5.1; en-US; rv:1.9.2.13) Gecko/20101203 Firefox/3.6.13\r\n
  - Accept: text/html,application/xhtml+xml,application/xml;q=0.9,\*/\*;q=0.8\r\n
  - Accept-Language: en-us,en;q=0.5\r\n
  - Accept-Encoding: gzip,deflate\r\n
  - Accept-Charset: ISO-8859-1,utf-8;q=0.7,\*;q=0.7\r\n
  - Keep-Alive: 115\r\n
  - Connection: keep-alive\r\n
  - Cookie: \_\_utma=240537730.1267018336.1290475102.1290475102.1290475102.1; \_\_utmz=240537730.1290475102.1.1\r\n

```

0030 ff ff 4f 5f 00 00 47 45 54 20 2f 20 48 54 50 50 ..O...GET / HTTP
0040 2f 31 2e 31 0d 0a 48 6f 73 74 3a 20 77 77 77 2e /1.1..Host: www.
0050 70 61 6c 65 6f 74 65 63 68 6e 6f 6c 6f 67 69 73 paleotec hnoiqis

```

Figure 5. Wireshark screenshot for an HTTP request.

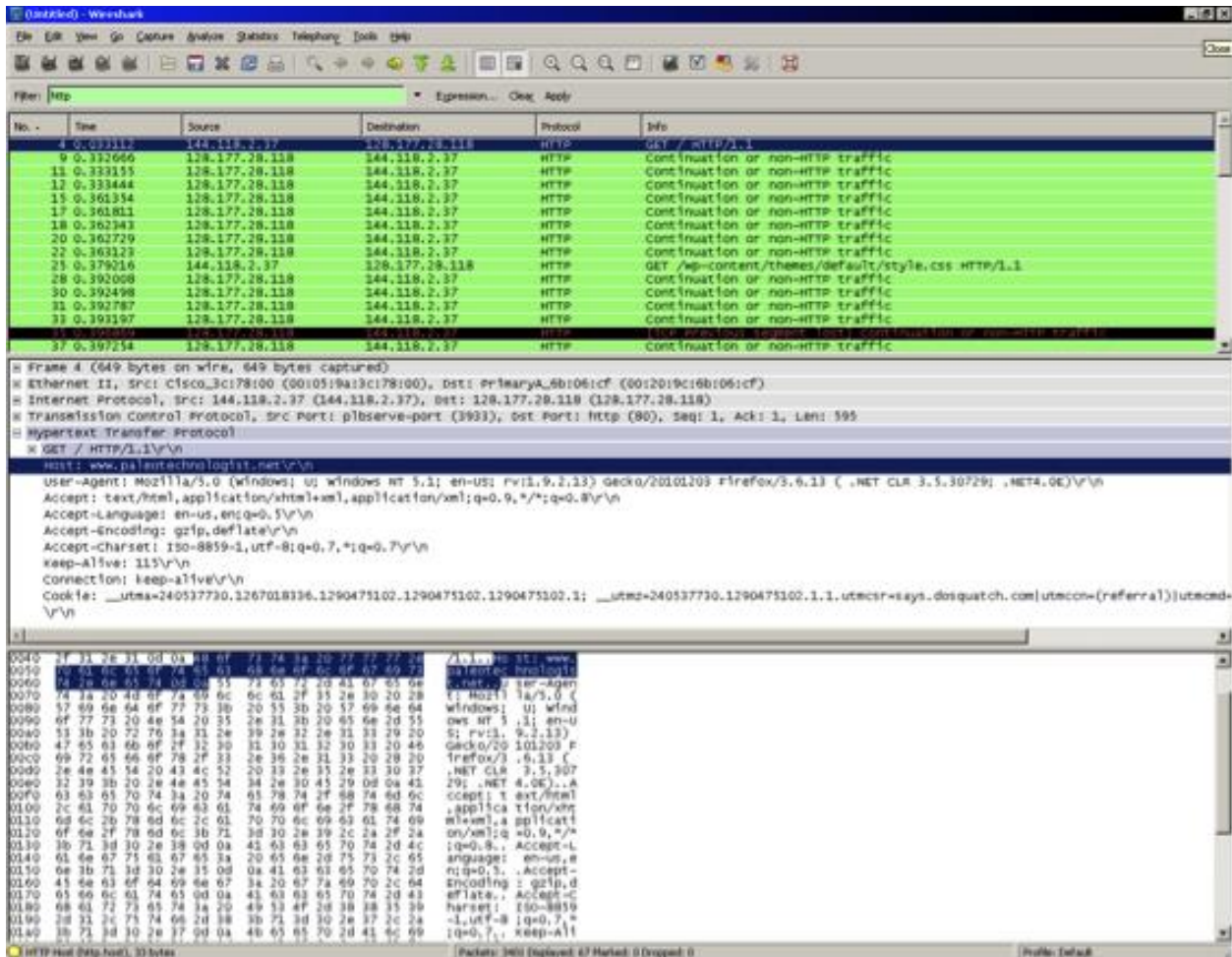


Figure 6. Screenshot of the response to the request from [www.paleotechnologist.net](http://www.paleotechnologist.net).

## Conclusions

This paper described a new online graduate engineering technology course in advanced networks for industrial environments. The course is intended to provide an in-depth overview of high-performance wired and wireless networks for industrial control, communications, and computing. The course uses a top-down approach to understanding layered protocols such as TCP/IP. The course includes topics aimed at the use of these networks in the industrial environment. These topics include performance/cost tradeoffs of various network topologies and industry specific network protocols such as ZigBee, CAN, and DPN, as well as common commercial networks that are finding their way into industrial applications such as Bluetooth and Wi-Fi. Hands-on experience in the online course is provided using the OPNET for performance modeling and simulation and Wireshark for network sniffing and protocol analysis.

## Bibliography

1. IEEE 802.3 Ethernet Working Group, <http://www.ieee802.org/3/>. Accessed October 1, 2011.
2. Working Group for WLAN Standards, <http://www.ieee802.org/11/>. Accessed October 1, 2011.
3. <http://www.bluetooth.com/English/Pages/default.aspx>. Accessed October 1, 2011.
4. <http://www.zigbee.org/>. Accessed October 1, 2011.

5. <http://www.dnp.org/>. Accessed October 1, 2011.
6. R. Bosch, CAN Specification Version 2.0, <http://esd.cs.ucr.edu/webres/can20.pdf>. Accessed October 1, 2011.
7. Kurose, James F. and Keith W. Ross. Computer Networking, Fifth Edition. New York: Addison-Wesley, 2010.

## **Robotics Games for STEM Education**

Ravi Shankar, Center for Systems Integration,  
College of Engineering and Computer Science,  
Florida Atlantic University, Boca Campus, Boca Raton, FL

Don Ploger, College of Education,  
Florida Atlantic University, Davie Campus, Davie, FL

Oren Masory, Ocean and Mechanical Engineering,  
College of Engineering and Computer Science,  
Florida Atlantic University, Boca Campus, Boca Raton, FL

Francis X McAfee, School for Communication and Multimedia Studies,  
College of Arts and Letters,  
Florida Atlantic University, Broward Campus, Ft. Lauderdale, FL

### Contact Information:

Ravi Shankar, [shankar@fau.edu](mailto:shankar@fau.edu), (561) 297-3470

## **Robotics Games for STEM Education**

Ravi Shankar, Center for Systems Integration, College of Engineering and Computer Science,  
Florida Atlantic University, Boca Campus, Boca Raton, FL

Don Ploger, College of Education, Florida Atlantic University, Davie Campus, Davie, FL

Oren Masory, Ocean and Mechanical Engineering, College of Engineering and Computer Science,  
Florida Atlantic University, Boca Campus, Boca Raton, FL

Francis X McAfee, School for Communication and Multimedia Studies, College of Arts and Letters,  
Florida Atlantic University, Broward Campus, Ft. Lauderdale, FL

### **Contact Information:**

Ravi Shankar, [shankar@fau.edu](mailto:shankar@fau.edu), (561) 297-3470

### **Abstract:**

This paper presents use of robotic floor games to enhance students' abilities and interests in STEM fields. Undergraduate students will build low cost robotic platforms that will be used by high school students to build their own intellectual and/or fun games. These robotic platforms (or kits) will be engineered to be inexpensive so high schools can afford them. We utilize open source software and hardware to achieve this.

### **Introduction:**

There is an unmet need among high school students to combine gaming and robotics in their own imaginative way. This requires students to apply knowledge of science and mathematics to practical problems in engineering. Often, when solving problems in school science and mathematics, students have difficulty applying the knowledge they have learned. In the examples shown in this study, the students are highly motivated because they have selected the problem to be solved.

We propose to use autonomous robots and mobile phones to teach math and physics to high school students. This paper is based on a new undergraduate engineering course that is being offered for the second time this semester. During the first offering, the enrolled students developed hardware and software components that will be used this semester to build a set of autonomous robots that can be managed from smart phones. The eventual goal is to develop two games (Tic-Tac-Toe and Chess) that can be played with these robots in an indoor arena. Thirty high school students are expected to take an introductory engineering course next summer when they will use these robots and learn to play and modify these games. Such a game integrates well the concepts of peer-to-peer cooperation, coordination, and communication, despite varied behaviors of robots, to achieve an overarching goal. We eventually hope to make these robotic kits low cost, modular, and incrementally acquirable, to enhance their



affordability by high schools. We will utilize open source software and hardware to achieve this<sup>1</sup>. Note that Lego sells a robotic chess system for \$30,000, typically out of reach for high schools.

The robots will use low power near-neighbor communication links, with optical/ sonar /IR/RF transceivers. These will allow the robots to self-organize in response to a chess move conveyed from a phone. Simple cameras will be used for robotic localization and navigation on & off the board. The high school students will be able to program the robots with different behaviors and plan/play different types of games/activities. This will increase their interest in the STEM curriculum and enhance their soft skills (team building, project management, communication, systems thinking, abstract thinking, and problem solving); this will also bring to the fore innovation and entrepreneurship, two hallmark qualities of the US economy, since these applications can be marketed, with these students sharing in the revenue (as per their institution's intellectual property policy).

### Method:

Figure 1 depicts mockup of a robotic chess game set up to communicate our vision (Please note: The students shown are enrolled at our developmental research school and their parents have signed Photo / Video Release forms.), Imagine that the chess pieces are powered by autonomous robots (notice the opposite color coasters under the chess pieces). Further imagine that the two players play the chess game, not by directly manipulating the chess pieces, but by making the move on the virtual chess boards displayed on the touch screen of their smart phones. The autonomous robot invoked to implement the move would negotiate its motion via occupied and unoccupied squares, to its ultimate destination. Communication and sensor technologies will be invoked to avoid collisions and to create a path, while actuator technologies will be utilized in executing the motion. STEM principles in the use of optics, sound, IR, and RF, motion, and distance estimation are evident. Global positioning, localization, and centering of the pieces will require the use of communication beacons (notice the 'red' cone near the bottom right) located at four corners of the board and use of physics and math principles for vectors and triangulation. Optimization of battery power, game speed, and acquisition cost will help develop problem solving skills also, in a fun and informal environment. The background utilization of engineering and technology principles, we hope, will enhance interest in (and reduce anxiety about) science and engineering. Advanced students will have access to C and Java-based tools for experimentation. Team-based new game development will allow the students to develop all the soft skills that are identified in <sup>2</sup>. Entrepreneurship and innovation, key US advantages in global competition, will be emphasized since the student teams will use their imagination in developing new games (and relevant marketing material, such as videos), and with the intent to market these games and to share in the royalties received.



**Figure 1: Mockup of Chess Game**

### **Advancement of Knowledge:**

Many of the algorithms can be implemented in a variety of ways, along the dimensions of STEM. Over the years, increasingly sophisticated and robust protocols and technologies (such as Bluetooth) have evolved (and are falling in price) that may persuade some to believe that this multi-dimensional exploration, while useful from a STEM learning perspective, is not economically productive, and thus may not advance knowledge. However, as chronicled by Christensen<sup>3</sup>, low cost solutions, developed after the arrival of ultra-sophistication in many a domain, have not only found a niche, but also have launched a host of new products and applications that compete with the mainstream technologies (an example is the rapid encroachment of USB flash drives into the domain of magnetic hard drives with terabyte capacity<sup>4</sup>). As an example, we may explore the use of Morse code with LEDs (and later on, via the Android monitor), for example, for peer to peer communication and recognition. Our first instinct was to develop this for educational purposes as a visible communication protocol (as compared to a non-visible protocol, such as Bluetooth), but cost and battery life considerations may pave the way for its use in our kits. Simply making these 'old' technologies available for experimentation by students may unleash their imagination in many new directions. Recent discussion on co-existence of Wi-Fi and Bluetooth<sup>5</sup> devices highlights the susceptibility of such links for both unintentional and intentional interference. A robust backup technology, perhaps for improvisation, may be low-tech.

### **Implementation of products and services in schools on a large scale:**

Our goal is to develop low cost robotic kits that are incrementally acquirable. Open sourcing will allow the cost to fall further. Thus, a school can initially acquire a few robots (or build them at still lower costs) at a cost of \$100 each, and incrementally add a few more robots every six to twelve months. Even a few robots will be able to give an adequate educational environment for the students. Availability of low-cost downloadable applications may persuade the pooling of robotic resources among schools to host games and design their own new games, which can then be marketed to generate revenue. Our experience with marketing Android smart phone applications developed at our university is the inspiration for this proposal. In this era of reduced budgeting, creative solutions are warranted; and further, in this era of heightened global competition, we need to emphasize innovation and entrepreneurship<sup>2</sup>, the earlier the better. We thus expect a trend towards low cost and open source solutions that will benefit all, not just a few major business entities. This is a welcome change and provides a way out in the changing world with pressing economic challenges. We also perceive the evolution of a healthy and social environment since such a game is not solitary (or a virtual on-line game), as many video games are, and can be held in open space as a community activity. Further, it will not be just limited to robotic enthusiasts.

We hypothesize that hands-on robotic games will enhance high school students' understanding and/or interest in the STEM disciplines. We were impressed with the phenomenal way high school students worked during summer '10 and summer '11 to develop applications on Google's Android Phone. We believe there is an unmet need among high school students to combine gaming and robotics in their own imaginative way. Robotics has excelled with super-sophisticated games, such as indoor soccer<sup>7</sup>, which may be the ultimate experience; this may, unfortunately, have raised the bar too high and made it a costly activity. Our goal is to bring robotics to a level that is within the reach of most schools and integrate it with the students' need for social networking.

Our design is based on our experience in rapid prototyping and incorporation of future skills identified in<sup>2</sup>. An overview follows:

**Game development as a ‘rapid prototyping’ activity:** The high school students will use a top-down system design approach in building their game software, during a six week summer session. The students will use good software development tools to program pre-built robotic platforms <sup>8</sup>. The game development process in the course will proceed in three stages: (1) STEM material coverage illustrated with PC simulations and field tests with robots (weeks 1 to 4), (2) Discussion of the Tic-Tac-Toe <sup>9</sup> and Chess games as a total experience (game playing to understanding the algorithms, technologies, and the code involved in implementing the game), during weeks 3 and 4, and (3) Use of these games as game platforms to implement their own games (weeks 5 and 6). Storyboarding, and discussions with faculty and engineering students, will help them implement their own game. The faculty will ensure that the high school students’ abstract model is implementable, while engineering students will help them implement this model. The high school students will do the actual implementation and troubleshooting, and will ultimately deliver a working game. Code development will be facilitated by a good GUI and APIs (Application Programming Interfaces).

### **Integration of hard and soft skills:**

We agree with the need to integrate both hard and soft skills in the curriculum, as discussed in <sup>2</sup> and actively incorporate it in all the courses that we teach. Team projects with STEM focus, and development of their own games, will lead to a quasi-competitive environment that keeps the experience educational and interesting at the same time. We add another element that <sup>2</sup> alludes to: the US advantage in innovation and entrepreneurship. The student games will be marketed and the resulting revenue will be shared with them, as per university IP (intellectual property) policy. This early exposure will help the students to fine tune their entrepreneurial skills and develop more innovative ideas along the way. As an anecdotal example, the first author’s early success with biomedical research and licensing, has persistently kept him fascinated with these aspects and led him to other successes.

**Results:** Impetus for this came from a local school that had a robotic club, but no robots. The boys and girls at this high school met every other week, but could make no progress, since they could not afford to purchase expensive robotic systems. Further, they lacked the ability to take advantage of existing low cost kits and integrate them. To address this, we offered a course in fall ’10 in which engineering students explored ways to build low cost robotic systems that can act as game platforms. The focus was on the design of hardware and software components to reach that goal<sup>8</sup>. We now have a good feel on the appropriate combination of new and old technologies that can lead to this <sup>8</sup>. We are currently offering a course on embedded robotics to undergraduate and graduate engineering students. They are working in groups of 3, typically with one each from computer science, computer engineering, and electrical engineering. The students have built low cost mobile robotic platforms (with a Uno platform from Arduino, ultrasound and infrared range sensors, and stepper motors with optical encoders) that will be used to create robotic art on large sheets of paper (6’ x 6’), by semester end. These robotic platforms are also being optimized for power dissipation. A course is also scheduled for next semester: A class of 15 high achieving high school students will be involved in building five stationary robots (‘beacons’) with Bluetooth, camera, and XBee technology. We have already completed App development to establish communication between Android phones and these beacons. Thus, all the building blocks will be ready for use by another group of high school students by summer 2011 or soon after. They will use these to develop robotic games as discussed earlier.

## Conclusion:

We have presented an outline for the use of robotic floor games to enhance students' abilities and interests in STEM fields. Here are some of the impacts: (1) Advances knowledge and understanding: STEM principles in the use of optics, sound, IR, RF, motion, and distance estimation are evident. Game development will emphasize the soft and entrepreneurship skills as well; (2) It is transformative, creative, original: This effort goes beyond typical STEM education, and gives the students an opportunity to improve their soft and innovation skills; (3) It enables advanced discovery and understanding: An open source and low-cost tool kit will open up the robotics field to all, enhancing potential for new ideas and products; (4) It helps enhance participation of underrepresented groups: Our experience with teaching courses on Android App development to high school students makes us believe that this process of fun, informality, creativity, and graphics will achieve this goal. (5) Enhances infrastructure for research and education: Sale of the robotic kits will help raise funds to sustain programs like ours. (6) Benefits to society: it is expected that some of these students will start their own businesses later on, impacting the local economy and community positively.

## Bibliography:

1. Arduino Website, <http://www.arduino.cc/>, accessed on 08/31/2011
2. National Research Council, "Research on Future Skill Demands", Washington, DC, [http://www.nap.edu/catalog.php?record\\_id=12066](http://www.nap.edu/catalog.php?record_id=12066), Free PDF Download, accessed in Dec 2010
3. Christensen, C.M., The Innovator's Dilemma: When New Technologies Cause Great Firms to Fail, *Harvard Business School Press*, Boston, MA, 1997
4. Phrolen, "New Flash Drive Holds 50 Terabytes!", <http://www.nowpublic.com/technology/new-flash-drive-holds-50-terabytes>, 9/22/2007, accessed on 1/2/2011.
5. HP Application Note, "Wi-Fi™ and Bluetooth™ - Interference Issues", [http://www.hp.com/rnd/library/pdf/WiFi\\_Bluetooth\\_coexistence.pdf](http://www.hp.com/rnd/library/pdf/WiFi_Bluetooth_coexistence.pdf), accessed on 2/1/2011
6. Shankar, R., McAfee, F.X., Harris, M., Silva, N., and Carvalho, G., STEM Education with Innovation and Entrepreneurship, ASEE Mid Atlantic Conference, Temple University, Oct 2011
7. Braunl, T., Embedded Robotics, *Springer*, Berlin, Germany, 2008
8. Our Robotics web site: <http://robotics.fau.edu/>, accessed on 10/15/2011
9. Ostermiller, S., "Tic-Tac-Toe Strategy", <http://ostermiller.org/tictactoeexpert.html>, accessed 1/6/11

## **STEM Education with Innovation and Entrepreneurship**

Ravi Shankar, Center for Systems Integration,  
College of Engineering and Computer Science,  
Florida Atlantic University, Boca Campus, Boca Raton, FL

Francis X McAfee, School for Communication and Multimedia Studies,  
College of Arts and Letters,  
Florida Atlantic University, Broward Campus, Ft. Lauderdale, FL

Michael Harris, Anthropology,  
College of Arts and Letters,  
Florida Atlantic University, Boca Campus, Boca Raton, FL

Norman Silva, Founder and Art Director,  
Silva Animation Studio, Inc, Ft. Lauderdale, FL

Georgiana Carvalho, Assistant Professor,  
College of Engineering and Computer Science,  
Florida Atlantic University, St. Lucie Campus, Port St. Lucie, FL

### Contact Information:

Ravi Shankar, [shankar@fau.edu](mailto:shankar@fau.edu), (561) 297-3470

## **Abstract**

We offer a compelling vision for bringing together like-minded faculty members across our several university campuses and colleges, to develop smart phone/ mobile applications in domains that are underrepresented but have substantial potential to succeed, with social, economic, or technological impact. A university is uniquely qualified to address such Apps given the close proximity of experts in non-overlapping and distinct fields. However, the close proximity is offset by silos built for administrative purposes. A group of faculty members and/or students drawn from the colleges of arts, business, education, and engineering have worked together over the past two years, not only to build bridges, but also to chalk up several positive outcomes. Our model has potential to be self-sustaining so it can be used to expand/scale up our model to include other groups and colleges in the ensuing years. The infrastructure built will benefit the university, partnering colleges, faculty, & students, while strengthening the social fabric of the university and lowering technology barrier so one can continue to focus on their passion, while benefitting from the rapid advances in science and engineering.

## **Introduction**

Smart phone applications are growing exponentially, fueled by several trends: quick and easy start-up, free/low cost and open source software and hardware, easy access to a rich library of application components, rapid prototyping, social networking, on-line marketing at multiple sites, and a large global market. We show here how these trends can be utilized by a university to realize more of its potential from the infrastructure.

## **Background**

A university is a bastion of knowledge; however, knowledge grows vertically in each domain, with insufficient communication across the domains. This leads to brittle solutions to real world problems and compromises any opportunity for useful innovation. Further, students graduate with limited appreciation of other skills, perspectives, and solutions that could have been brought to bear upon on a given problem. This is not unique to our university; but we are small enough to explore new ways of collaborations, without impacting academic efficiencies. Further, in bigger universities, there is depth in various colleges to duplicate some of the non-core capabilities and become self-sufficient. Our process presented here will help our and other mid-sized universities to find opportunities to collaborate and establish a unique brand of innovation that distinguishes us from others. Academic, financial, and economic returns to the participants and the local community are welcome additions.

This has potential for financial and economic return to the participants; however, equally importantly, this will build bridges for better understanding of each others' domains, setting up future research and teaching collaborations. Also, students involved in such projects, while taking courses in their colleges, will work in teams across domains, thus gaining important real-world experience. These collaborations may also lead to small business formations and a cottage industry that could impact the local economy positively.

## **Methods**

Over the past two years, we have taught Android related courses to graduate and undergraduate engineering students, and high school students, in a synergistic manner. Based on this experience, we believe that our development cycle will follow this one-year cycle:

In the spring semester, a group of faculty members drawn from engineering, arts/graphics, business, and/or an application domain come together to teach and mentor a group of about 20 to 30 undergraduate engineering students. These students take on the roles of a programmer, graphic designer, or project manager, in groups of three students. By semester end, seven to ten Android smart phone application platforms are developed. As can be appreciated, these are code-intensive projects, and it is expected that all the students will contribute to the programming effort, in addition to the effort pertinent to their roles.

During the ensuing summer semester, we teach a three-week course to 30 high school students; they will take these application platforms and use their creativity and imagination to develop marketable smart phone Apps. A group of faculty members and undergraduate students, with core expertise in engineering, graphics, and business, as pertinent to smart phone Apps, will teach, mentor, and support this intense effort. The students in each three-student group are asked to choose their roles (programming/ graphic design/ project management) in their group, and learn and contribute in that role. At the end of the three-week session, a group of distinguished academic and business leaders judge presentations of these student groups. The groups discuss and demonstrate their App, and present a marketing video. These student groups are presented with award certificates based on the evaluation of the judges and internal evaluation of the teaching staff.

During the fall semester, a group of engineering and graphics undergraduate students, savvy in Android programming and graphics design, will use feedback from student focus sessions to fine tune the Apps and add university related information. Business majors will help with the focus sessions and marketing the Apps.

All the authors, viz., undergraduate and high school students, and the faculty members, involved in the App development will share in the revenue generated from the marketing effort. A portion of the revenue will be channeled to the faculty group involved to seed their continued collaboration, to develop proposals and offer these courses during the ensuing year. Remainder of the funds is used by the university to help other faculty members.

Notes: 1. Graduate courses have been used so far to develop new components in the areas of the semantic web, and data acquisition & signal processing. These will become building blocks for future one-year programs as described above. These define new and challenging areas that smart phones will find increasing applications in. 2. During the spring '12 semester, we have planned to offer concurrent courses in engineering, graphics, business, and an application domain (social science) for students in those individual disciplines. However, the idea is to facilitate students' cooperation and collaboration across these disciplines to develop more realistic and authentic applications. 3. The students and /or their parents have signed photo/video release forms and intellectual property forms of the university.



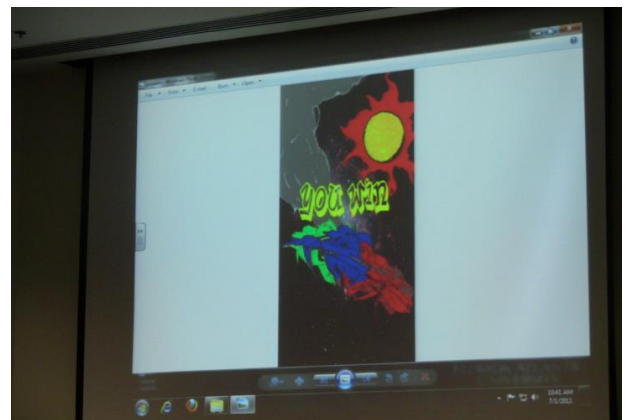
**Figure 1.** A visitor tries an App during ‘Show & Tell’.  
Block Drop



**Figure 2.** First Prize Winner App (1 of 2):  
Block Drop

## Results

During fall '09 and spring '10 engineering undergraduate students developed ten base App platforms (for fun games), while engineering graduate students developed Android components and libraries to ease the development process further. During summer '10 high school students used their creativity and imagination to develop marketable Apps from these base App platforms. They were ably supported by four faculty members (from engineering and arts) and four undergraduate students well versed in Android application development. We used Burnette's book <sup>1</sup> as the Text. Four of these Apps were then fine tuned during fall '10 by four engineering undergraduate students. We expect to market these by December '11, after having satisfied all the requirements of the university and the Android On-line Store. This first effort was financed with funding from an SBA grant for one year, during 9/09 – 8/10, and funding from the university during 9/10-12/10. A total of \$12,000 (from the SBA grant) was distributed to these high school students, based on evaluation of their Apps by a group of judges <sup>2</sup>. We hope that marketing these Apps will generate sufficient funding to continue to refine and develop new fun game Apps for smart phones. We repeated this process this summer, which culminated with 30 high school students (from 9 high schools) developing ten more Apps. We will market six of these Apps. We will present at the conference the marketing videos of three Apps that were adjudged to be the best by a panel of academic and industry leaders <sup>3</sup>.





**Figure 3:** A student team demonstrates during ‘Show & Tell’ Nuclear Madness

**Figure 4:** Art in another App:

We also developed 7 Apps in an undergraduate class during spring ’11 that were focused on games with social impact. This involved three professors, one each from engineering, graphics, and social science. Several similar collaborations have sprung up since then and will address Apps in others areas such as K-12 education, patient care, hearing aids, productivity aids for the disabled, and the semantic web <sup>4</sup>. In terms of impact, our Android website, rich with tutorials, application code, and videos, has had ~80,000 visits since its inception in Feb 2010 <sup>5</sup>.

## Conclusions

From a national perspective, US competitiveness in science and technology can be enhanced by increased involvement of the millennium generation in science and technology, not just as end users, but also as developers of modern gadgets and smart phone applications. Our experience shows that we can assemble students and faculty members from core domains pertinent to smart phone Apps, viz., arts/graphics, business, and engineering, and application domains, to build marketable gadgets and applications that bring them revenue, confidence, and excitement in shaping their future, and also increase their involvement in science and engineering, thus reducing the apprehension of non-engineers and non-scientists toward science and technology.

## Bibliography

1. BURNETTE, ED., Hello Android, 3<sup>rd</sup> Edition, *The Pragmatic Bookshelf*, Raleigh, NC, 2011
2. Nurturing Young Minds, <http://www.ceecs.fau.edu/news/nurturing-young-minds> , accessed on 10/15/11
3. Marketing Videos for top three winners from summer ’11: : <http://vimeo.com/album/1660512>, accessed on 10/15/11
4. Our Semantic Web site : <http://semanticweb.fau.edu/>, accessed on 10/15/11
5. Our Android site: <http://android.fau.edu/>, accessed on 10/15/11

## **Robotic Applications to Enhance Transportation Security**

Authors: BRIAN LINHARES  
Student, Mechatronics Engineering,  
Vaughn College of Aeronautics and Technology:  
Email: [Linhares\\_brian@hotmail.com](mailto:Linhares_brian@hotmail.com)

Advisor: HOSSEIN RAHEMI, PhD  
Professor and Chair, Engineering and Technology Department,  
Vaughn College of Aeronautics and Technology,  
Email: [hossein.rahemi@vaughn.edu](mailto:hossein.rahemi@vaughn.edu)

# Robotic Applications to Enhance Transportation Security

## ABSTRACT

The international community has been very sensitive about security since 2001. Government agencies spend billions of dollars, yet a solution has not been found in which civilians feel safe while not feeling disrespected by inspection officials. Guard dogs, officers and military personnel can practically be found throughout the world guarding airports and other forms of mass transportation locations. But as previously mentioned, even with all of these resources, narcotics and explosives still manage to elude authorities. An autonomous robot with good public relations will provide security without a martial presence. Special sensors can work as a canine does; the sensors periodically take in air samples to find out if any highly used specific explosive chemicals are in the area. This tactic is used by American soldiers in Iraq, but has yet to be properly introduced for civilian applications. The idea would be to draw people closer with monitors displaying information, thus increasing the efficiency of the sensor greatly. Also with several ultrasonic sensors, the robot will be able to move through a crowd without injuring or causing a disturbance.

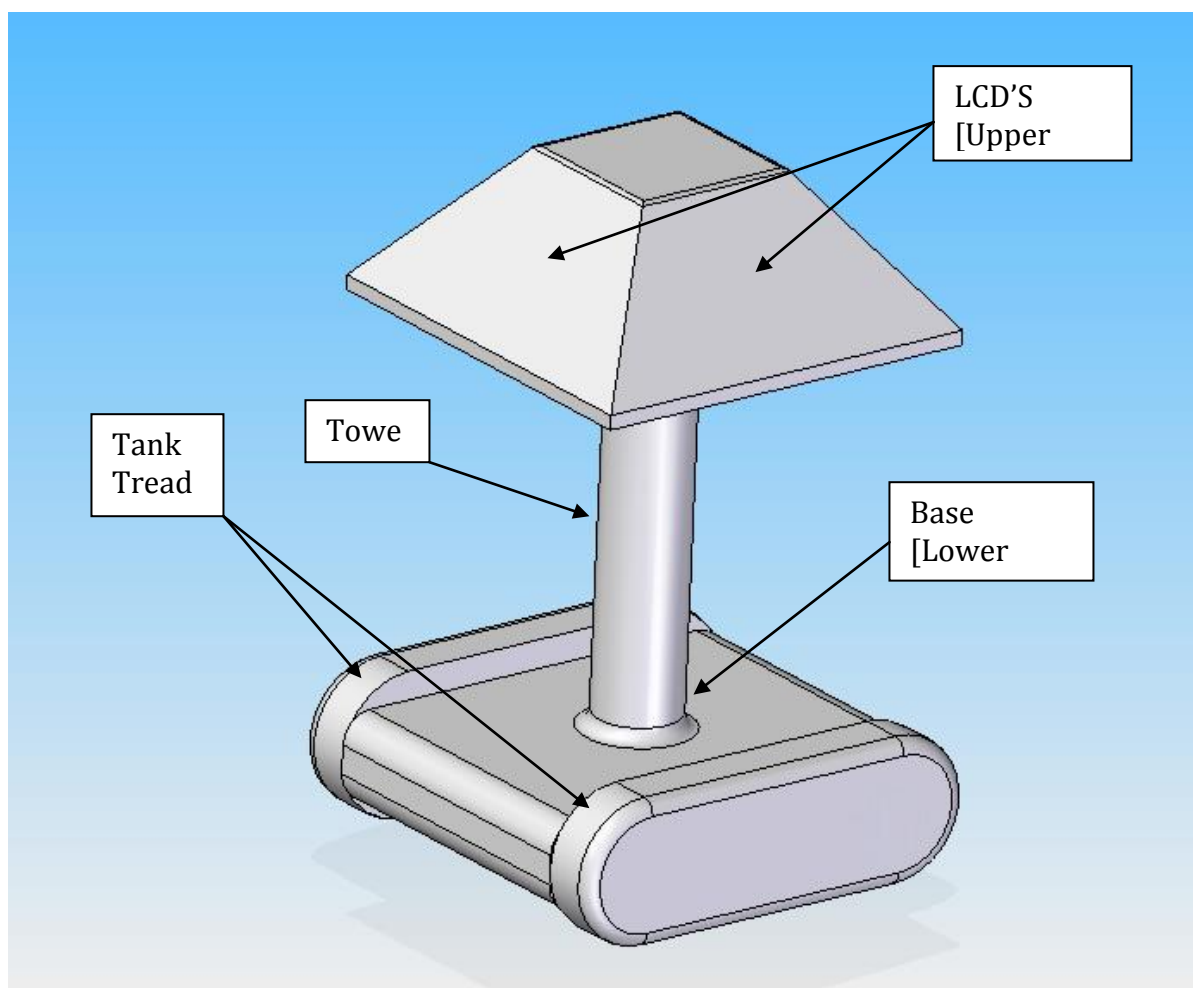
## INTRODUCTION

Beneficial advancements have always had their military counterparts that can do harm to society. This concept came together with equipment that is currently available, creating something new and innovative. Security in airports and other forms of mass transportation is very important since those are locations that are more frequently targeted. Terrorists and drug smugglers all have one thing in common, they leave behind a trace that can be tracked with the right personel and equipment [1]. It usually starts with home made, over-the-counter products which are put together to make explosives, which if exposed leaves a miniscule trace in the air. Sensors exist that can detect specific chemicals in the air by taking air samples continously but are less sensitive with distance. We determined that the next step to help resolving this problem would be to make it autonomously mobile.

Attaching a chemical sniffing sensor to a robot that can easily roam a preset location without interfering or worrying travelers will allow security personel to have another set of eyes on the floor. This would also permit a greater area to be checked. The robot will have four screens on it that will feature saved data and could even be used to stream commercials if needed to lower costs. Technologically advanced security units could lead to several prosperous investments for the locality.

## Frame and Electronics

People tend to bump into things when they are in a hurry, especially if they are late. This factor helped contribute to the shape of the frame and locations for the electrical components due to the nature of its purpose. The frame is set to have a low center of gravity to prevent it from toppling over easily. This was accomplished by placing most of the electrical components inside of the base. The remaining four LCD screens and the chemical sensors are located inside of the tower upper half. Power distribution to the top half is done by running electrical wires through the six inch aluminum pipe that secures it to the base. This in fact protects the wiring from liquids and other foreign agents that may be corrosive and damage the components [2].



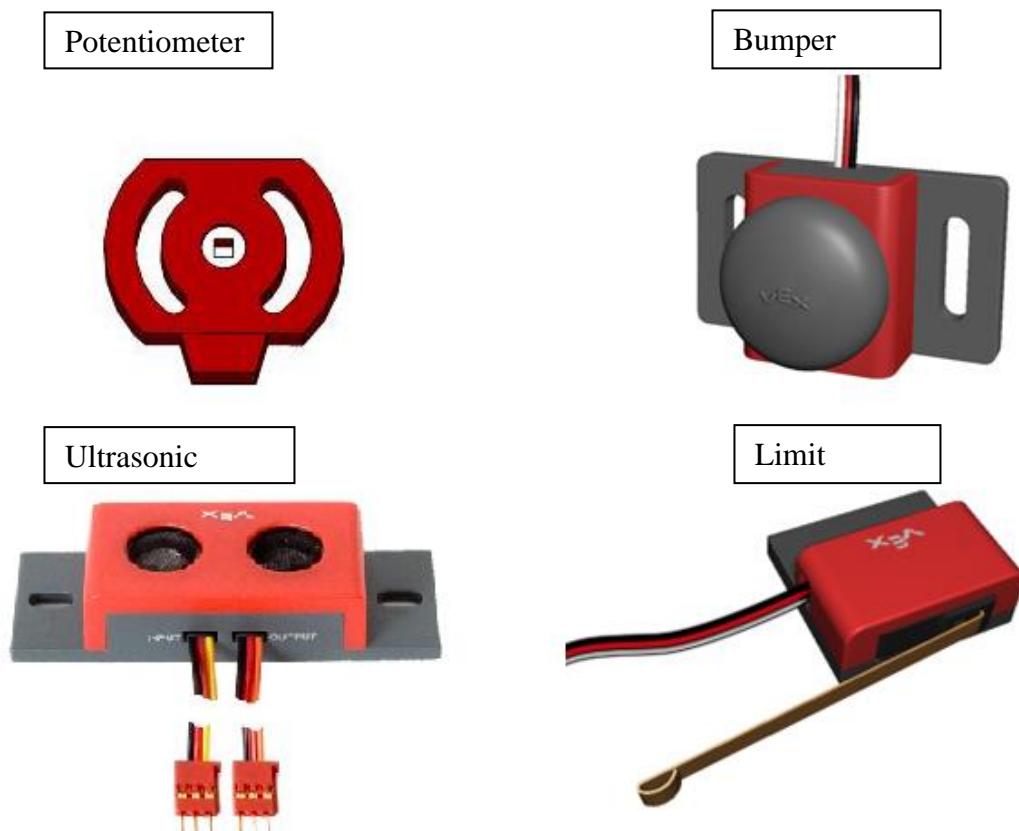
**Figure 1: Frame and Electronics**

The top half structure is mainly made up of four LCD screens which are held together by aluminum sheets and brackets keeping it sturdy yet light to remain having a low center of gravity and a chemical sensor located underneath the top half platform.. With the addition of the chemical sensor, this should place the weight of the upper half above the tower at more or less 20 pounds. The bottom half will consist of electrical components such as the 12 volt battery, micro processor, and the ultrasound sensors. The aluminum beams making up the rectangular frame will also have supports to place the motors that will power the tank treads. The center aluminum pipe will be held in place by three L shaped brackets that will be attached directly to the lowest level of the rectangular frame. This allows that a second level of three L shaped brackets be connected to the pipe a little higher connecting it to the top cross beam section of the rectangular frame.

### **Sensors and Programming**

Chemical sniffing sensors are innovative and are being used by the American military. The sensor that our group has found most interesting would be the Triacetone Triperoxide sensor. Triacetone Triperoxide is usually used for shoe bombs and is extremely hard to detect. Since it can be made easily with readily available components, it is being widely used by terrorists. Therefore if further advancements are made, this sensor can be used which will help in detecting this specific chemical that is suspect to investigation [3].

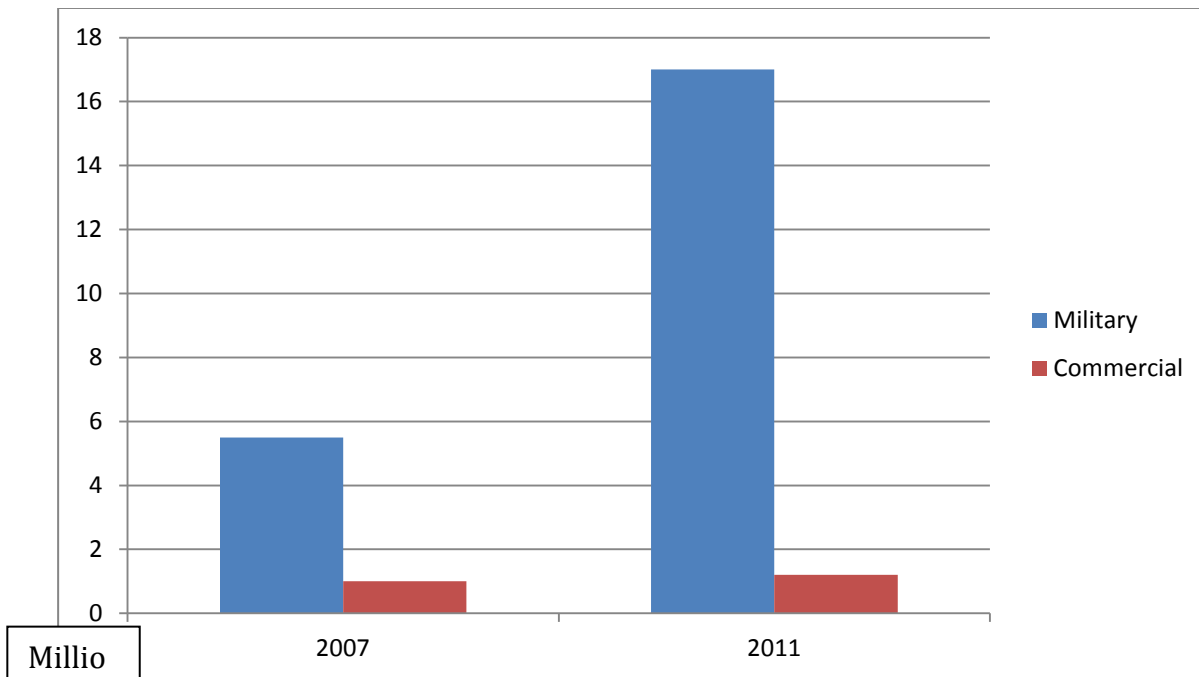
The robot will be autonomous requiring some form of sensor to prevent it from running into obstacles or falling down a flight of stairs. This is where ultrasonic, bumper, limit switches, and potentiometer sensors come into play, which are inexpensive and are very efficient [4]. The potentiometer is an analog sensor which collects info from something physically moving which in this case would be the motors for the tank treads. The following sensor would be the bumper switch which is activated through touch, activating a preset program which could allow the robot to back away in case it unfortunately hits an obstacle. Limit switches operate in the same form as a bumper switch but are much more sensitive.



**Figure 2: Sensors**

The ultrasonic sensor is a key feature in this design since it will prevent the robot from falling down stairs and would also prevent any collisions with obstacles by sending out an ultrasonic wave and picking up how fast it returns. If the ultrasonic sensor produces a value lower than a preset value than this will indicate that an obstacle is near. Presently we are using ultrasound sensors. Sensors can be mounted using small bolts that are 1/8 of an inch in diameter and about 1/4 of an inch in length including the head. Since the bolt will be attached directly to the sensor, no nuts are required. Our Mechatronics group constructed a small robot with all four of these sensors and noticed that whenever one sensor did not pick up something, the other would act as a back up. This greatly increased its success in not bumping into any obstacles that we laid out for it.

## Efficiency



**Figure 4: Robotic Division**

As shown in the above graph [5], the use of robots are skyrocketing in the military service due to the fact that the army has recognized the full potential of robotics. This alone should be relevant information when trying to figure out how to better prepare security at a civilian facility.

The robot is fitted with sensors that can detect a specific and potentially hazardous chemical, without alerting the perpetrator. This robot is compact and takes minimal amount of space to store. As it has four screens which are inclined at an angle, passengers could have easy access to gate or flight information. If a potential threat is noticed, it will automatically alert the security workers while following the trace of Triacetone Triperoxide from where the threat is coming. If an emergency situation arises, it could be equipped with an alarm system which will start and will signal people that something is occurring which will lead them to pay more attention to any announcement.

### **Design**

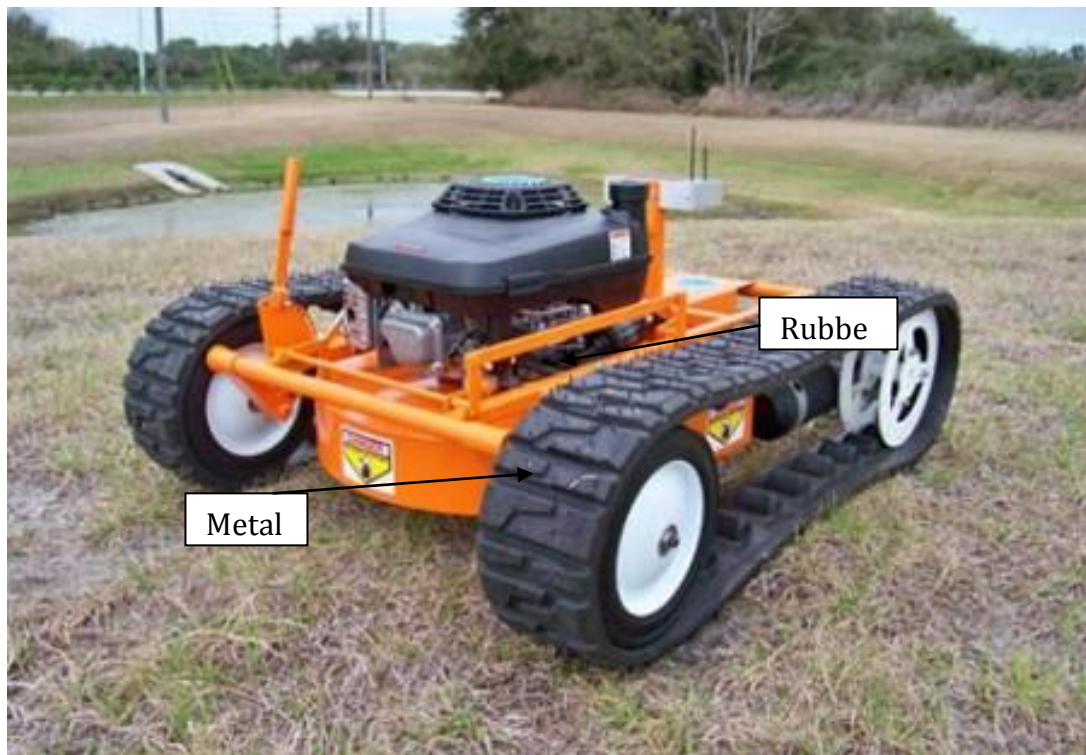
The design of the robot is simple yet complex at the same time, the structure and components allow it to freely roam around without hindering anyone. Counterweights are placed at certain locations to prevent toppling over and ultrasonic sensors are placed in particular sections of the robot to prevent bumping into and also falling down a opening or flight of stairs. Aluminum sheets are used to weight reduction and to also protect internal components by acting as a skin for the robot. Aluminum beams are used to provide a sturdy base and a aluminum pipe is used to support the top half of the robot. The processors and other important components are located in easily accessible positions with panels to replace when necessary.

### **Mobility**

The mobility of the robot is the foundation of its operation. The decision to apply tank treads to this mobile lab came from the basis that tight corners will not allow a simple rack and pinion system which is seen in automobiles to work. The application of the tank tread is to allow mobility in large and tight locations also allowing maneuverability over various types of terrain such as dirt and mud. Taking into consideration that various airports have smooth floors, the tank tread system is made of metal to

withstand the tension put out by the motors but the top half of the belt that comes in contact with the floor has a rubber cap to allow better movement.

The simplicity of the assembly also helps in future maintenance that could easily be done by someone with simple automotive skills further reducing maintenance costs. This design demands that the belt be four inches wide and be able to sit on two, nine inch diameter tracks placed 10 inches apart from center to center. The belt may be made out of aluminum links to help reduce weight but still maintain strength to withstand the tension created by torque and friction. The rubber caps that will be placed on the metal belt links can be attached in by a strong adhesive or by standard thin bolts.



**Figure 5: Track Assembly Example**

### **Public Acceptance**

Due to the design, the robot will be a short term investment that will prove inexpensive to the consumer given that companies will want to advertise their products more directly to travelers at an airport on the LCD's built on the robot. The robot features four LCD flat screens which will be used to not only display flight information, but also ads.

The non-martial appearance will give travelers a more comfortable traveling experience to and from airports more frequently, which could increase tourism leading to higher airport revenues. Presently, travelers are met with searches due to security especially in America, and many don't seem to like the TSA for it. Passengers tend to get alarmed with the sight of military personnel patrolling with heavy weapons such as the M-16 assault rifle. Our robot will give passengers more peace of mind knowing that there is something patrolling alongside the security personnel making it safer which is always a priority.

## **Conclusion**

Artificial intelligence is the intelligence of machines and the branch of computer science that aims to create it. This robot can be classified as "the study and design of intelligent agents" where an intelligent agent is a system that perceives its environment and takes actions that will maximize its chances of success. John McCarthy, who coined the term in 1956, defines it as "the science and engineering of making intelligent machines." Our robotic agent accomplishes its goals autonomously without disturbing the public. This in turn shows that if there is a military counterpart to every beneficial creation then there must be a counterpart to every military creation that will be beneficial to society. The military have run successful tests showing that their bomb sniffing robots accomplished their set tasks, thus aiding soldiers in the battlefield.

## **REFERENCES**

- [1] Battle robots in Iraq point the way to the future of warfare The Times. (2010)  
<http://www.timesonline.co.uk/tol/news/world/iraq/article7132501.ece>
- [2] Thomas L. Floyd (2007) *Electronic Devices Conventional Current Version*, 8<sup>th</sup> edition, Prentice Hall.
- [3] Sniffing out Shoe Bombs: A New and Simple Sensor for Explosive Chemicals Science Daily. (2010)  
<http://www.sciencedaily.com/releases/2010/10/101019152608.htm>
- [4] Sensor Accessories Vex Robotics. (2010) <http://www.vexrobotics.com/products/accessories/sensors>
- [5] World Robot Population Guardian. (2008)  
<http://www.guardian.co.uk/technology/blog/2008/oct/13/week>



## **SECTION 6**

## **Development of a Computer Skills Class for Older Adults Using a Service Learning Model**

DIANA SCHWERHA, PhD

Diana J. Schwerha is an Assistant Professor in the Department of Industrial and Systems Engineering in the Russ College of Engineering and Technology at Ohio University. Dr. Schwerha's research interests focus on applying ergonomics to retain older workers and designing usable technologies. She teaches courses in ergonomics, statistics, and quality control and is a trained Six Sigma Black Belt.

AARON JONES

Mr. Jones is a graduate student in the master's degree program in Industrial and Systems Engineering in the Russ College of Engineering and Technology at Ohio University. He research interests focus on the role of frustration in website usability.

SHIJING LIU

Ms. Liu is a graduate student in the master's degree program in Industrial and Systems Engineering in the Russ College of Engineering and Technology at Ohio University. Her research focuses on the usability of mobile applications for older users.

SERTAC OZERCAN, MS

Mr. Ozercan is currently a doctoral student in Computer Science at the Russ College of Engineering at Ohio University in Athens, OH. He received his Master's degree in Computer Science through the Russ College of Engineering and Technology at Ohio University in 2010. Among his research interests are human-computer interaction, computer graphics, and game development.

JIE ZHOU, MS

Ms. Zhou is a PhD student in the Mechanical and Systems Engineering doctoral program in the Russ College of Engineering and Technology at Ohio University. Her research interests focus on RFID (Radio Frequency Identification) applications and data mining.

# Development of a Computer Skills Class for Older Adults using a Service Learning Model

## Abstract

Older adults are the fastest growing group of internet users. While older users want to use the internet for communication, social networking and information seeking, many users are not competent in the basic skills. The goal of this service learning project was to have graduate students enrolled in the class, Aging and Ergonomics, design and conduct a series of computer skills training classes for older adults in the community. By conducting the class, students would benefit from learning how to design a training program for a user group different from their peers while also serving older individuals in the community. Within the course of a quarter (10 weeks), students recruited participants, designed the training, and conducted the training. The five one-hour classes were: introduction to computers, introduction to the internet, introduction to Microsoft Word, images and videos and Facebook. Participants completed weekly evaluations which were then used to improve future sessions. Feedback from the sessions indicated that teaching environment and pace of learning were among the most noted participant concerns. This presentation will also discuss recommendations on working with community partners to develop service learning projects for engineering students, designing do-able projects, and creating evaluation metrics that help students improve their interaction with the community.

## Introduction

Computers are widely used in our daily life and play an important role in modern society. Older adults are the fastest growing segment of computer users and they need computers to access websites, get health services at home, communicate with families and friends, and stay connected to the world.<sup>1</sup> Many older adults do not have enough experience with computers, and they are interested in improving their computer skills. Therefore, effective basic computer training is important to older adults.

Service learning is an experiential education method which consists of two parties: providers and recipients, where both parties can learn from this educational experience.<sup>2</sup> Service learning can include a wide range of programs, such as community service, field education, volunteerism, and internships. One situation where service learning can be most effective is when the learners are actively involved in the practice and they are learning with a purpose.<sup>3</sup> Both providers and learners benefit from service learning.

The goal of this project was to develop and conduct a service learning project within the Russ College of Engineering and Technology at Ohio University. The project consisted of graduate students in the class, Aging and Ergonomics, designing and conducting a series of five classes in the use of computers for older citizens within the community. This project utilized intergenerational service learning, and it provided students and older adults with the opportunity to learn through mutual connections with one another.<sup>4</sup> Through this relationship, students benefited from the acquired knowledge, while the older adults benefitted from the maintained social engagement.<sup>5</sup>

## Training Materials

Five training sessions were designed by the students. The sessions were each intended to be approximately one hour in length and were on the following topics: introduction to computers, introduction to the internet, introduction to Microsoft Word, images and videos, and introduction to Facebook. Every training module contained four sections designed to last no longer than ten minutes, and each section was assigned to a student to teach. This time frame allowed for twenty minutes to address questions and concerns of the older adults throughout the training class period. See Table 1 for a list of topics and learning objectives.

Since collaboration in a team is an important aspect when preparing documents, students used Google Docs to coordinate and collaborate on presentations. Google Docs provides a free, web-based application

that enables users to create and share documents, spreadsheets and presentations. It also allows real-time collaboration among users. Using Google Docs enabled the team to see the progress of presentations, and cut down on the email traffic. Since it is web-based, anyone could edit the document from any computer with Internet access, allowing flexibility.

#### Participants

Participants were recruited from The Athens, Village (TAV) as well as from the local community.<sup>6</sup> The Athens Village is one of the virtual villages for older people that are emerging across the country. They provide members with information relevant to: 1) the community, 2) independent living, and 3) community discussions.<sup>7</sup> TAV is restricted to older persons within the Athens community who are sixty years of age or older. The Athens Village is used by its members to keep in touch with one another, have access to health care information, gain assistance for personal help, and keep current on local events they might be interested in attending. The professor for the class had previously worked with TAV on another project, so the collaboration with this group was already established.

Recruiting of participants was initially done by the professor but then was continued throughout the project by the students. Participants were not paid for their participation. All individuals participated on an informed consent basis and the project was approved by the Ohio University Institutional Review Board. Each week up to ten individuals participated. Individuals were not required to attend all sessions. During the five weeks of training, weekly attendance ranged between 5 to 9 older adults, age 50 to 88 years old. Details of the participants are shown in Table 2.

Table 1

#### *Learning objectives for training topics*

Topic	Module Title	Learning Objective
Introduction to Computers	Module 1: Introduction to computers	Identify what a computer does and its components
	Module 2: Desktop	Identify Desktop and Taskbar and their uses
	Module 3: Accessibility settings	Customize your mouse and display settings
	Module 4: File types and file organization	Create, open, and save documents
Introduction to Internet	Module 1: What is the Internet?	Access the Internet
	Module 2: Access the Internet via a browser	Describe how to access information on the Internet and accessing websites
	Module 3: Email	Know how to send/receive an email
Introduction to Microsoft Word	Module 1: Overview of Microsoft Word	Describe basic functions about Microsoft Word
	Module 2: Basic functionality	Be able to open file, edit file and save file
	Module 3: Printing	Be able to set the printing properties and print file
Images and Videos	Module 1: Overview of Images	Describe what an image is and different types of

---

		images
	Module 2: Images in Word	Insert a picture into Microsoft Word
	Module 3: Compressing Images	Know how to compress an image
	Module 4: Videos	Describe what a video is, different types of videos, and know how to play videos

---

Introduction to Facebook	Module 1: Introduction to Facebook	Describe what Facebook is, how to create and account, and find people you know
	Module 2: Your profile, status updates and messaging	Change profile information, post status updates and messages to friends
	Module 3: Privacy Settings	Describe how to change privacy settings to protect your privacy
	Module 4: Sharing Photos and Videos	Share photos and videos

---

Table 2

*Demographics for participants in computer training classes*

Week		Count	Mean Age	SD	Min	Max
1	Total	9	68.67	11.62	50	88
	Male	2	67	5.66	63	71
	Female	7	69.14	13.17	50	88
2	Total	6	69.17	14.09	50	88
	Male	2	66.5	6.36	62	71
	Female	4	70.5	17.62	50	88
3	Total	6	71.83	13.98	50	88
	Male	1	71	.	71	71
	Female	5	72	15.62	50	88
4	Total	5	73.6	11.1	62	88
	Male	1	71	.	71	71
	Female	4	74.25	12.71	62	88
5	Total	6	68	7.62	62	82
	Male	3	66.33	4.51	62	71
	Female	3	69.67	10.79	62	82
Total	Total	32	70	11.31	50	88
	Male	9	67.56	4.25	62	71
	Female	23	70.96	13.04	50	88

**Procedure**

Participants initially signed up for the training and then were given reminder phone calls for the rest of the sessions. Each session was given in the Industrial and Systems Engineering Teaming Lab that contained computer terminals and a large touchscreen display on the wall in front of the terminals. The professor introduced the training and then the students each gave a part of the training. The training was given through a Power Point presentation and presentation slides were printed in three slides per page handouts, allowing participants to take notes on the side. Live demonstrations were also given by the presenters in each step to allow participants to understand and practice. During the exercise of each module, some older people were unable to follow the exercise instructions, so we had to teach the exercise more slowly. This may have influenced opinions of the older adults who were able to finish the exercise and had to wait before going further. At the end of each training session, participants then completed an evaluation and other suggestions. Suggestions were used to improved future sessions.

**Results and Discussion**

After each training section, the older trainees were requested to fill out evaluation forms (Appendix A), and answer five questions as following:

- A. I learned the basics of this topic;
- B. The training was organized in a way that I could understand it easily ;
- C. I think that the training was difficult to follow;
- D. I believe that I have a foundation to learn more about this topic;
- E. I believe that the handout was useful.

They answered these questions using the following scale:

1	2	3	4	5
Completely disagree		neutral		completely agree

Question C was reverse coded to ‘I think that the training was easy to follow’ during analysis. Since we had small numbers of participants, we utilized non-parametric statistics for the analysis and we also collected participant comments as qualitative data. Median responses for each question during each session are listed in Table 3.

Table 3

*Descriptive Statistics: Q1, Q2, Q3, Q4, Q5*

Variable	session	N	N*	Minimum	Median	Maximum
Q1	1	8	1	1	4	5
	2	6	0	4	4.5	5
	3	6	0	2	4.5	5
	4	5	0	3	5	5
	5	6	0	2	4.5	5
Q2	1	9	0	1	4	5
	2	6	0	4	5	5
	3	6	0	4	5	5
	4	5	0	3	5	5
	5	6	0	3	4	5
Q3	1	8	1	1	3	5
	2	6	0	2	5	5
	3	6	0	2	4	5
	4	4	1	2	5	5
	5	6	0	2	4	5
Q4	1	9	0	1	4	5
	2	6	0	3	4.5	5
	3	6	0	4	4.5	5
	4	5	0	4	5	5
	5	6	0	4	5	5
Q5	1	9	0	4	5	5
	2	6	0	3	5	5
	3	5	1	4	5	5
	4	5	0	4	5	5
	5	6	0	4	5	5

In order to determine whether participants had significantly different responses we conducted two types of Kruskal-Wallis tests: 1) tests on the median response between questions within a session and 2) tests on the median response for a given question between sessions. The first test sought to answer whether questions within a session differ in their median response. The second test sought to answer whether type of training affect a person's response on a particular question.

In response to the first test, no statistically significant differences were found for the median responses between questions within each session. For the second test, none of the questions had significantly different median responses between weeks (at  $p=0.05$ ). However, when weeks were pooled together, median responses were different between questions ( $DF = 4$ ,  $p = 0.042$ ) with the median response for questions 1 and 3 being 4 and the median responses for the other questions being 5. Questions 1 and 3 had to do more with their learning rather than the organization of the material. We believe that these



lower ratings may have been due to the amount of material presented and the inability for us to provide longer practice sessions.

In the evaluation form, trainees were also requested to write down their comments about the computer training. Some comments focused on the training context and computer problems:

- 1) I would like to learn about sizing photos, Skype.
- 2) How to locate missing emails? Why do they go to trash or spam? Why do they go to trash or spam, if previously received?

Some comments were about the material, hardware, software, and environment:

- 1) Everyone was very helpful but the amount of material presented was about 90% more than could be absorbed in one hour by a novice.
- 2) Noise in the room is distracting.
- 3) The main problem is that your software is so far advanced beyond what we have at home that it makes it hard to adapt this info to my equipment.

Others were about the students, faculty, and other things:

- 1) I have a little problem with hearing. Appreciate young people who speak aloud.
- 2) All my questions were thoughtfully answered.
- 3) Thanks for your patience. I learned even more this week!
- 4) Thanks for the help. I hope you have more classes. Please call me if you do.
- 5) Very helpful. I am learning a lot!
- 6) Thanks. We appreciate your time, patience and skills.
- 7) It would be nice if students could be paid (by us) to come to our home (if we want it) to go over this same stuff in our own computers. Just to adapt.
- 8) I liked the class! I hope you have more. Thanks. Please call if you have more classes.
- 9) I liked the class. Everyone help. They've done a very good job. Thank you!

Students' perceptions about their service learning experience

Service learning is concerned with the learning of the providers as well as the participants. After five weeks of training sections, students had a deeper and integrated understanding of conducting training for

older adults. Based on the preparation for each training module, the teaching experience, and the evaluation parts, the conclusions for the students' perceptions about the training experience were:

- 1) When developing each training module, students needed to prepare more examples and exercises for older adults than for young adults and adjust the teaching tasks to make them easier to be understood by older adults.
- 2) During each module, students tried to keep the atmosphere as informal as could be allowed so that older adults would feel less awkward about being in a service learning program.
- 3) Older adults started to open up and feel more comfortable when students sat down next to them rather than standing, also they would follow along better when students did examples.
- 4) When students were helping the older adults one-on-one by doing things slowly and taking everything step by step, the older adults understood very well and caught up quickly.
- 5) Students gained confidence in presentation skills, computer knowledge, and teaching older adults.

#### Suggestions on ways to design a service-learning project

Working on a service learning project during the course of one quarter (or semester) was very rewarding. However, logistical challenges can exist that could dampen the experience. From our work, it is recommended that the faculty member develop the relationship with the community group and establish the project before the beginning of the quarter. In addition, it can be very helpful if the IRB proposal is started before the beginning of the quarter. We were very fortunate in that the professor already had a working relationship with the community partner.

The second recommendation that we would suggest is that the project be scoped so that it can be completely done within the course of the quarter. Often we underestimate the time that a project takes and the project and evaluation cannot be completed. By appropriate scoping, the students experience the full-circle of activities and are not rushed through the evaluation component.

Third, we believe that knowledge of expectations is very important to intergenerational service learning projects. Students should have knowledge of user group capabilities and the goal of the project should be clear to the participants. This facilitates between learning and overall satisfaction.

#### Conclusion

For an integrated service learning program, providers and recipients are both important. In our computer training program, students (providers) and older trainees (recipients) got different benefits from this service learning project. Students gave back to their community, earned course credit, gained experience in working with older adults, and gained experience in working as a group to accomplish a goal. The older adults acquired more knowledge about five topics relating to computing and were encouraged to build on the basics that they learned when they worked at home on their own computers.

Although there were many benefits of this program, the limitations of this study cannot be neglected. It was only a five week training program. The evaluation of longer term transfer and learning could not be evaluated. The number of trainees was limited, less than ten people for each session that made it difficult to reach broad conclusions. Larger sample sizes and longer experience times would be preferred. In addition, all the computers used by the trainees were school computers with guest accounts, used only using Windows 7 operating system and a recent version of Microsoft Office. It was difficult to address the differences between what was taught in class against the different hardware and software the older

adults had at their homes. For instance, one person dropped out because she did not have Windows 7 on her own computer. For a better service learning program, multiple operating systems and software should be considered.

## Bibliography

- [1] C. B. Mayhorn, A. J. Stronge, A. C. McLaughlin and W. A. Rogers, (2004). "Older Adults, Computer Training, and the Systems Approach: A Formula for Success," *Educational Gerontology*, 30, 185-203.
- [2] Furco, A. (1996). "Service-Learning: A Balanced Approach to Experiential Education." *Expanding Boundaries: Service and Learning*. Washington DC: Corporation for National Service, 2-6.
- [3] Billig, S., H. (2000). Research on K-12 School-Based Service-Learning The Evidence Builds. *Phi Delta Kappan*, 81(9), 658-664.
- [4] Wescott, A., & Healy, T. C. (2011). The Memory Bridge Initiative on Service Learners. *Educational Gerontology*, 37(4), 307-326.
- [5] Shippee, T., Schafer, M., & Pallone, K. (2008). Building the "Bridge": Linking Gerontology Education to a Local Retirement Community. *Gerontology & Geriatrics Education*, 28(4), 57-70.
- [6] *The Athens village*. (2011). Retrieved June 5, 2011, from <http://www.theathensvillage.org>
- [7] Carroll, J. M., & Rosson, M. (1996). Developing the Blacksburg Electronic Village. *Communications of the ACM*, 39(12), 69-74.

Appendix A

Evaluation Form

Service Learning Training: Computer Training for Members of the Athens Village

At the end of the session, please answer the following questions:

1. Please list your age \_\_\_\_\_
2. Please circle your gender. M      F
3. Please circle the name of this training:
  - a. Introduction to Computers
  - b. Introduction to the Internet
  - c. Introduction to Microsoft Word
  - d. Introduction to Working with Pictures
  - e. Introduction to Facebook

Please answer the following questions using the following scale:

1	2	3	4	5
Completely disagree		neutral		completely agree

- |  |   |   |   |   |   |
|--|---|---|---|---|---|
| 4. I learned the basics of this topic  | 1 | 2 | 3 | 4 | 5 |
| 5. The training was organized in a way that I could understand it easily         | 1 | 2 | 3 | 4 | 5 |
| 6. I think that the training was difficult to follow                             | 1 | 2 | 3 | 4 | 5 |
| 7. I believe that I have a foundation to learn more about this topic             | 1 | 2 | 3 | 4 | 5 |
| 8. I believe that the handout was useful   | 1 | 2 | 3 | 4 | 5 |
| 9. Please use the space below to write any further comments about this training: |   |   |   |   |   |

**Student as Developer: An Alternative Approach to Sustainability and  
Green Building High School Education Modules**

Bhavna Sharma, Ph.D., Post-Doctoral Fellow  
Mascaro Center for Sustainable Innovation and  
Dept. of Civil and Environmental Engineering  
University of Pittsburgh

Birdy Reynolds, Research Associate  
Learning Resources and Development Center  
University of Pittsburgh

BHAVNA SHARMA

Post-doctoral fellow, Mascaro Center for Sustainable Innovation and the Department of Civil and Environmental Engineering, University of Pittsburgh, Swanson School of Engineering, Pittsburgh, PA, 15261, bhs7@pitt.edu.

BIRDY REYNOLDS

Research Associate, University of Pittsburgh, Learning Research and Development Center, Pittsburgh, PA, 15261, birdy@pitt.edu.

# **Student as Developer: An Alternative Approach to Sustainability and Green Building High School Education Modules**

## **Abstract**

An increasing focus in K-12 educational outreach is on science, technology, engineering, and mathematics (STEM) fields. A challenge in educating students about STEM topics is the ability to communicate the key concepts on a level that engages the students. Common approaches to K-12 students' experience with engineering education involve reading about engineering then completing worksheets or designing artifacts for competitive purposes. Less common is an approach that has students design materials for other peer learners.

Through partnership between the University of Pittsburgh's Learning Resources and Development Center (LRDC), Swanson School of Engineering (SSOE) and the Quality of Life Technology Center (QOLT), the NSF RET competition provided rising tenth grade high school students with the opportunity to serve as interns at the Mascaro Center for Sustainable Innovation (MCSI). The interns, from a parochial school in Western Pennsylvania spent five weeks learning about sustainability and green building, for the purpose that each student would then develop a week long education module.

The interns were tasked with development of a sustainability and green building module for high school students in the hope that students would share the best ways in which they learn. The interns were asked to free think, any possibilities, to teach students about sustainability, while linking the topic to one of the following content areas: math, science, or history. The internship provided them with a unique opportunity to develop content for a high school class, while learning about sustainable engineering topics. This paper discusses lessons learned with this less common approach to engineering education with respect to features of the design that seemed to work well and features that require strengthening as well as additional outcomes from the internship.

## **Introduction**

The National Science Foundation (NSF) Research Experience for Teachers program is but one instance of industry, government, and university-based programs that seek to insert engineering into K-12 classrooms through providing engineering research experiences to K-12 teachers. There are diverse goals for Engineering Education efforts commonly including: increasing public appreciation of engineering research, especially new areas of research, such as nanoscience or tissue engineering; increasing public appreciation of engineering work; increasing student science and math performance; and increasing the supply of future engineers overall and with greater gender, socio-economic, and racial diversity. The LRDC/SOE RET site focus is to increase the supply of future engineers and the diversity of such engineers by increasing math and science performance of traditionally underrepresented student. Authentic engineering design presents an effective platform to attain this goal.

A number of different RET models have been proposed and these vary primarily in the extent to which engineering research or K-12 activities are emphasized. As shown in Figure 1, many RET sites either have a strong focus on engineering research (Fig. 1A) or a strong emphasis on K-12 academic year development (Fig. 1B). In those sites with a strong research component, teachers are placed within a team and perform deep scientific research on a somewhat narrow engineering topic. The research lab experience is rigorous and demanding, and helps the teachers to build content knowledge in that particular domain, however, this experience does not change teacher beliefs that their students could engage and be successful in similar rigorous and demanding practices. In addition, since the focus of these sites is on teacher development, there is no real effort to ensure that the knowledge that teachers obtain gets translated into the classroom during the academic year activities.

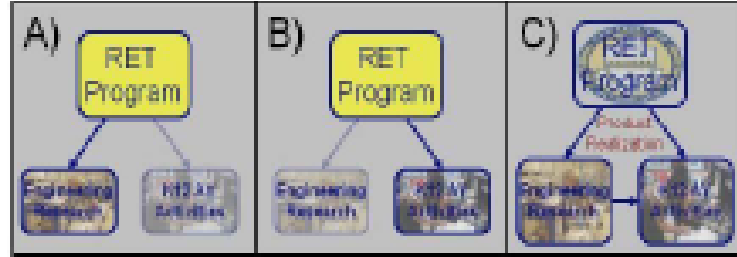


Figure 1: RET Site Examples

In contrast, the RET sites that focus on K-12 academic year activities (Fig. 1) develop in-depth curricular materials that can be implemented in K-12 science and math curricula. In these sites, RET participants often do little hands-on research and are exposed to engineering projects through presentations or observing others doing research. This approach may give the impression that teachers are capable of developing curricular materials but only engineers are capable of solving authentic engineering problems. This 'look but don't touch' model potentially reinforces the belief that their own students cannot be successful engineers. With this RET model, participants are likely to gain a limited perspective on the field of engineering and not very likely to be able to convey to their students what engineers actually do.

A third approach to RET programs that we have developed tries to create a strong linkage between the engineering research and K-12 activities (Fig. 1C). In our case, concentrating on the process of product realization has facilitated the strong linkage. Product realization can effectively be achieved as part of actual engineering research by a broad cross-section of teachers, and thus allows teachers to experience first-hand what engineers actually do. Product realization, as a process, is also something that can be directly incorporated into a significant chunk of the K-12 curriculum, perhaps more so than particular pieces of engineering research content. In other words, the process of product realization becomes the bridge between research and the classroom.

The Mascaro Center for Sustainable Innovation (MCSI) at the University of Pittsburgh is a center of excellence in sustainable engineering focusing on the design of sustainable neighborhoods. MCSI focuses on collaborative engineering and innovative research, translating the fundamental science of sustainability into real products processes. In addition to MCSI's sustainability research, extensive outreach programs work with local schools, afterschool programs, community organizations and non-profits to increase awareness of sustainability and green building concepts.

The LRDC/SOE RET and MCSI internship provided a unique opportunity to develop module content with direct input from rising tenth grade students. The interns, from a parochial school in Western Pennsylvania, served as MCSI interns for five weeks, learning about sustainability and green building, for the purpose that each student would then develop a week long education

module. The interns were tasked with development of a sustainability and green building module for high school students in the hope that students would share the best ways in which they learn. The interns were asked to free think, any possibilities, to teach students about sustainability, while linking the topic to one of the following content areas: math, science, and history. The internship provided them with a unique opportunity to develop content for a high school class, while learning about sustainable engineering topics. This paper discusses lessons learned with this less common approach to engineering education with respect to features of the design that seemed to work well and features that require strengthening as well as additional outcomes from the internship.

## Background

### *Methods of K-12 Engineering Education*

We distinguish five common approaches for bringing engineering to K-12 students, which we discuss from the basis of the limited research literature that exists and our observations of many different programs. The first two approaches involve staying out of formal K-12 classrooms. The first is to hold a variety of forms of informal programs in the summer, at weekends, or after school. The second is to hold a variety of forms of engineering competitions, the most popular of which these days are robotics competitions, such as the FIRST Lego League. These out-of-school efforts likely do well in promoting interest in engineering, however, they are difficult to organize with equitable access because they depend upon community intellectual experience with Engineering) and financial resources, which are rarely held or distributed equitably. Furthermore, complete separation between engineering outreach and formal K-12 classroom experiences gives the impression of an irrelevance of formal mathematics and science for engineering applications, and we risk developing students with an interest in engineering but no ability to survive college engineering training.

A third approach is through formal engineering curriculum units that vary in length from one week to multiple years of coursework such as Project Lead the Way, and the Infinity Project, followed separately from other curriculum content, or integrated with mathematics or science curricula e.g., such as in FOSS, or STC middle school science curricula. Here there are a number of interesting tradeoffs. Longer curricular units may be harder to insert into the already packed and highly constrained curricula, but may be more likely to produce meaningful levels of changes in students. Our approach involves a compromise of focusing on six to eight week-long units that are easier to insert into the timetable than full year curriculum units but are long enough to produce meaningful levels of change in students.<sup>1</sup> Another challenge of formal engineering curriculum units is teacher professional development. Most K-12 teachers have little experience with engineering, in addition to commonly having weaknesses in science and mathematics knowledge, and thus they require significant professional development in order to successfully implement engineering curriculum material. Again there is an equity complication: the students with the greatest needs often have the teachers with the weakest knowledge and skills.

A fourth approach involves various forms of professional, faculty, or student engineer visitations into classrooms, conducting demonstrations, guest lectures, or as teaching assistants. This approach is very commonly ad hoc, based on engineers directing attention to their own children's schools, and thus raising further equity of access issues. This approach also has more structured instances with industry, professional organizations, and university organizations. For example, the U.S. National Science Foundation's (NSF) GK-12 Program provides funds for engineering graduate students to spend 15 hours per week in K-12 classrooms for an entire year. These structured programs can strive towards equitable access, however, by not focusing on teachers or the curriculum, there is relatively little residue left in the school of these classroom visitation programs once they leave the classroom. The teacher is left mostly unchanged and is not given tools to build upon this foundation or continue the work in later years.

The fifth approach of improving K-12 Engineering Education is professional development programs for K-12 teachers, be they elementary generalists, or secondary math, technology, or science specialists. These programs typically occur in a front-loaded fashion, with teachers getting most or all training prior to start of implementation of new engineering approaches in their classrooms (e.g., in the summer or at a regional, national, or international teacher conference). Such front-loading provides little incentive or support for classroom implementation. Another feature of such programs is that they are carried out as a volunteer effort on the teacher's part, rather than mandated participation by the



schools. It is known that stronger teachers are more likely to volunteer for extra professional development opportunities,<sup>2</sup>

1B. Reynolds, M.M. Mehalik, M.R. Lovell and C.D. Schunn. (2009). Increasing Student Awareness of and Interest in Engineering as a Career Option through Design-Based Learning. *International Journal of Engineering Education*, pp. 1-11.

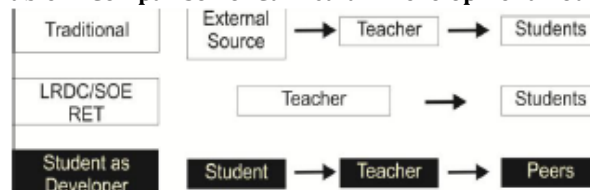
2 L. Desimone, A. C. Porter, B. F. Birman, M. S. Garet, and K. S. Yoon, *The Newsletter of the Comprehensive Center Region VI*, 8, 2005, p. 3.

and equality of access issues can arise, unless selection for admission into such programs explicitly addresses equity issues. A variation of the professional development approach that we explore in this paper is the NSF's Research Experience for Teachers (RET) program, in which teachers are paid to participate in engineering research and then must bring some aspect of that experience back into their class-rooms. By working with teachers, the theory is that the impact of the program will be felt for years to come, however, teachers often struggle with finding good integrations between their research experiences and classroom implementation.

*Internship approach*

Designing materials for other learners may have potential as another strategy for K-12 engineering education. While conceptually, “*student as teacher*” has been considered in the reciprocal teaching model, “*student as developer*” has received little attention. Design-based learning shifts the role of the student from “consumer” to “designer” in an effort to teach science. While students remain consumers of a “prescribed” curriculum, the design of the unit gives them a sense of autonomy to “design a product that meets a need in your own life.” This approach has shown to increase student engagement and motivation for learning science. We considered using a parallel approach by placing students in the developer role to create a module to teach sustainability to their peers. The goal of this approach was to deepen student understanding of sustainability and sustainable engineering. The methodology built upon the previous stated approaches, specifically, we considered how curriculum typically is disseminated from the developer to the user to the audience. Traditionally, curriculum is created by an external source (*developer*) and imported into the classroom. The teacher (*user*), an internal classroom source, is tasked with translating and communicating the developed curriculum to the students (*audience*). The LRDC/SOE RET model integrates the role of developer and user through teacher experience. Teachers develop curricular material, which translates their own engineering experience into classroom learning. In this way the teacher assumes a dual role of developer and user for their students who remain in the role of audience (Table 1). The student as developer approach, as shown in Table 1, explores how shifting the role of a student impacts student learning. The primary step in this approach places the student in the role of developer while the teacher and student peers remain in the traditional role of user and audience, respectively. This approach follows the traditional model, but serves to establish a baseline to understand student efficacy.

**Table 1: Comparison of Curriculum Development Models**



Previously our RET student intern experiences were to further the designs that they began in the classroom to deepen their engineering understandings, however, with this approach the learning resided only with the interns themselves. The student as developer approach seeks to be a bridge between individual student learning and classroom/peer learning by tapping into the ways in which students communicate and understand. Rather than a top down approach from external curriculum developer to students, this approach

may be a more organic way to access student interests and understandings about sustainable engineering topics.

### Framework for this approach

Our framework utilizes a similar structure as product realization to design curricular materials for classroom use. Over the past six years, the LRDC/SOE product realization process has been effective in impacting teacher classroom practice.<sup>3</sup> The LRDC/SOE RET framework includes an

3 Y. Doppelt, Y., C.D. Schunn, E. Silk, M. Mehalik, B. Reynolds, and E. Ward. (2009). Evaluating the impact of a facilitated learning community approach to professional development on teacher practice and student achievement. *Research in Science & Technological Education*, 27(3), 339-354.

experience for teachers, which results in development of a teacher generated artifact that is used in the classroom with students (*consumers*). Utilizing this framework the interns engaged in a process to deepen their understanding of sustainability concepts, and then generated an artifact that would be used by teachers in the classroom to teach sustainability concepts (Fig. 2).

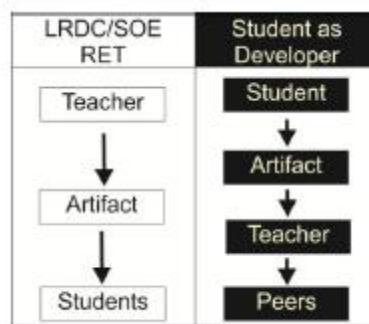


Figure 2: Internship Design Framework

### Internship Design

The internship design included specific constraints designed to address the difficulty of integrating engineering education into existing curricula, a common shortcoming of the previously discussed K-12 engineering education methods. The internship required the interns to develop a week-long module to communicate sustainability concepts. They could choose from four topic areas: green building, energy, water and green materials. Additionally, they were required to link the topic to one of the following content areas: math, science, and history. In this way, the interdisciplinary nature of sustainability would be naturally integrated and provide a lens through which to situate their module. In contrast to the content requirements, the students were not constrained in the methods (such as hands-on demonstrations, experiments, games, etc.) they could use engage students learning of the concepts.

The five-week internship was divided into steps that allowed the students to build components of the module, as shown in Table 2. The first week served as an introduction to sustainability and the topic areas. The interns were required to pick a content area and topic within the first week. The introduction week was framed to introduce the students to different teaching strategies and consisted of discussions, diagramming concepts and definitions on the marker board, and mapping product life cycles. This introductory week included a green building tour, as an example of a real-world application. Based on the introduction week the interns selected the following topics and content area: (1) Energy and Mathematics and (2) Green Building and History.

Table 2: Internship Schedule and Deliverables

Week	Topic	Deliverable
1	Define	Concept Module
2	Organize	Proposal Letter
3	Develop	Module Outline
4	Evaluate	Assessment Tool
5	Review	Symposium Presentation and Poster

The required deliverables included: a) a proposal letter written to the principal of a school to propose use of the module in a class; b) a detailed outline of the module, which also served as a teaching plan; c) an assessment tool(s); and d) a presentation and poster, which was presented at the MCSI summer Undergraduate Research Program (URP) symposium. Through iterative design, the interns refined their modules and associated materials to achieve the final product. The interns were given the flexibility to work on the deliverables in any order, while the deadlines remained fixed. In addition to the green building tour, the students also participated and interacted with undergraduate and graduate students in several activities over the five weeks, such as a competitive jeopardy game on the four topic areas, which was moderated by two undergraduate research students.

### Intern Modules

Students were unfamiliar with the subject of sustainability at the start of the internship. Linking their selected topic to a content area served as a lens to situate their module and supported their emerging understanding of the subject. Students' choice of a content lens reflected their interests and tended to be their favorite school subject. For example, one of the female interns enjoyed mathematics and used that as a lens for her unit on Energy. Below is an excerpt from the module abstract (written by the student):

*The module focuses on linking sustainability and energy to mathematics. The module explores renewable versus nonrenewable sources of energy, the advantages and disadvantages, ecological footprints, as well as meaning of "green." To link the sustainability concepts to the math content, the module will include the process of converting energy into electricity, through a series of equations to calculate the amount of energy generated by the various sources...*

Mathematical models that describe energy conversion helped this student make sense of sustainable energy concepts. Below is an example problem this student included in her module to help other students understand energy conversions. For example:

*Example Problem: Energy from Fossil Fuels*

*Five tons of coal is used every day in Mike's town to generate electricity. Assuming that the process is 20% efficient, how much electricity is generated every day?*

*Step 1. Energy Generated = Amount of coal (tons) × Energy Conversion (Btu/ton)*

*Step 2. Electricity Generated = Energy Generated × Electricity Conversion (kWh/Btu)*

*Step 3. Efficiency = Electricity Generated × Efficiency (%) = kWh/ton*

Once the basic conversion equations were established, the intern showed how to build on this with subsequent energy sources, such as solar or wind turbines, taking into consideration pertinent features such as area. Our male intern's favorite subject was history. He used a regional context to highlight his chosen topic on green buildings. Below is an excerpt from the letter he wrote to his principal:

*The focus of the module is on the history of Pittsburgh and its movement toward green buildings and sustainability and leaders. I also think this will be a good way to teach high school students because of*

*Pittsburgh's leadership in the field of sustainability and green building... [this will] give [students] a better understanding of Pittsburgh and its efforts for a better place to live.*

Considering local pioneers and their contribution to regional greenbuilding was a way for this student to relate his understandings to sustainability. Through exploration of local pioneers such as Carson, Heinz, and Lawrence, this student recognized the tenets of sustainable engineering as resource for solving local issues. In his module, accessing students' prior knowledge of local history supported the relevance of the need and how green buildings are effective solutions to these problems.

In both modules, students created curricular materials for teachers, which included lecture/review notes (PowerPoint to support classroom discussions), in-class worksheets (word searches, fill in the blank about, and well specified word problems), and homework assignments.

### ***Lessons Learned***

The outcomes from this approach yielded various levels of understanding regarding student learning. The framework for the approach served to establish a baseline to understand student efficacy. In the approach of student as developer (Fig. 2), the development of an artifact served as the process in which the interns deepened their understanding of sustainability engineering through the lens of a self-selected alternate discipline area. This supported the widely accepted belief that we understand at one level when we learn for ourselves, but at a different often deeper level when we have to "teach" that understanding to someone else. The open-ended nature of the task allowed students to choose the mappings based on their own interests and strengths. Also, development of the artifact was framed within a real world context, albeit communicated within a personal context.

To further explore the effectiveness of student as the developer framework, the approach needs to be expanded to parallel that of an LRDC/SOE RET, in which the student assumes the role of both developer and user, while the student peers remain as the audience. Potential future steps include structured assessment of student learning throughout the internship to provide a gauge of skill development, as well as the depth of knowledge in regard to the topic. The process of designing pedagogical materials also required more structure. The pedagogical model the students used is their own module is a translation of their traditional experience of learning and what worked for them. If we want them to generate a different pedagogical model we need to provide them with an experience of innovative teaching methods to fully grasp the potential impact on their own student learning.

### **Summary**

In summary, this paper explores the less common approach that has students design materials for other peer learners. Rising tenth grade high school student interns, from a parochial school in Western Pennsylvania, spent five weeks learning about sustainability and green building. The interns were tasked with development of a sustainability and green building module for high school students in the hope that students would share the best ways in which they learn. The internship approach explored the potential of student as developer of materials for other learners as another strategy for K-12 engineering education. The internship design included specific constraints designed to address the difficulty of integrating engineering education into existing curricula, a common shortcoming of the previously discussed K-12 engineering education methods.

The goal of this approach was to deepen student understanding of sustainability and sustainable engineering. The student as developer approach explored how shifting the role of a student impacts student learning. The primary step in this approach places the student in the role of developer while the teacher and student peers remain in the traditional role of user and audience, respectively. The outcomes from this approach yielded various levels of understanding regarding student learning,

including the process in which the students developed the module in relationship to their own understanding and the need to frame the topic and content within a real world context. To further explore the effectiveness of student as the developer framework, the approach needs to be expanded, in which the student assumes the role of both developer and user, while the student peers remain as the audience. Potential future steps include structured assessment of student learning throughout the internship to provide a gauge of skill development, as well as the depth of knowledge in regard to the topic.

## **A Reverse Engineering Project for an Introductory Engineering Course**

ATIN SINHA  
Professor & Coordinator of Engineering  
Albany State University  
Albany, GA

ATIN SINHA

Atin Sinha received his Ph.D. from University of Tennessee Space Institute in Aerospace Engineering in 1984 and worked in Learjet and Honeywell before joining academia. He is working in the Albany State University since 1999 as coordinator of the transfer engineering program and teaches most of the engineering courses. He is instrumental in establishing the Engineering Laboratory that incorporates the reverse engineering facility. He is a licensed professional engineer.

# A Reverse Engineering Project for an Introductory Engineering Course

## Abstract

A reverse engineering project is used as a part of the laboratory class of the introductory level undergraduate engineering course every fall since 2007 to train students attending transfer engineering program conducted by Albany State University with Georgia Institute of Technology. In earlier years students scanned their teammate's face which proved to be a challenge. The new reverse engineering project introduced in 2009 allowed students to scan a part in NextEngine and rebuild it in RapidWorks software that proved to be significantly easier and guarantees project completion.

## Introduction

Reverse Engineering has been around in one form or another for quite sometime. Reverse engineering may be defined as the process of taking the finished product and reconstructing the design data in a format from which new part or mold can be produced. For any object, even those with an organic form, the geometrical coordinates may be generated by a Coordinate Measuring Machine which is time intensive and prone to measurement errors. However, with the availability of 3D scanners from various manufacturers has made it possible to get a precise definition of the object by obtaining the point cloud of laser generated data. In general, the scanner manufacturer supplies software to reconstruct computer definition of a "true" copy of the original by aligning the scans, filling holes, polishing and buffing the model. For a great number of applications, this reconstructed model will be adequate. However, when combined with a standalone reverse engineering software, it is possible to recreate the object knowing the design intent checking against the dimensional accuracy and functional requirement. Reverse engineering software also generates model in stl format that can easily be opened in commercial CAD software as a generic model to extended the original design as needed. The final model can be used to make a prototype in a rapid prototyping machine thus significantly shortening the product development cycle.

## Hardware and Software Tools

As is evident from the above discussion, in order to develop a prototype based on an existing object, one requires a 3D scanner and software, reverse engineering software, CAD software and a rapid prototyping machine. Discussion below describes different software and hardware tools currently available.

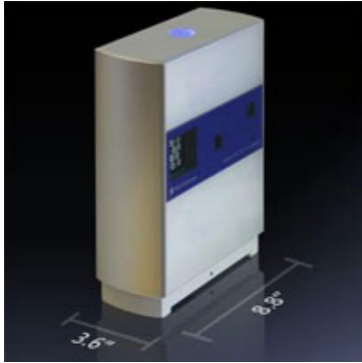
The additive manufacturing machine was first introduced 1987 where a part is made of depositing or sintering layers thermoplastic resin by a laser beam driven by the part's model definition generated by CAD software as the part evolves from the bottom up. Collectively the process is known as Rapid Prototyping<sup>1</sup> (RP). Though today there are players in this industry making RP machine based on different methods, a few of them such as Straysis and Z-Corporation dominate the market segment for small build envelop. Both of them has tabletop RP machine known as 3D Printer though they are based on different methods. The Straysis 3D Printer<sup>2</sup>



in  
of  
solid  
many

(shown in the previous page) is based on fused deposition modeling and the Z-Corporation's machine is based on powder binder method.

As in RP, numerous vendors are currently manufacturing 3D scanners suitable for different market segment from cataloging a large architectural monument to developing a custom dentures or prosthetic device. Too many scanners are available to provide even a brief description of each. However, all of them are based on laser generated data being processed by separate software to reconstruct the object. The more expensive ones do automatically process multiple scans to reconstruct the object without any human intervention thereby significantly shortening the product development cycle. The flip side of this amazing technology is that the cost is about 10 times more of those where manual trimming, aligning, filling holes etc. is required. NextEngine scanners (shown in left) made by NextEngine Inc<sup>3</sup>. is probably the least expensive scanners available which require manual reconstruction of the object in the vendor supplied



ScanStudio software. A similar product though somewhat higher priced, E-Scan (shown in right) is available from 3D – Digital Corp.<sup>4</sup> Both of these scanners are portable and can be mounted on a stand for easy operation. In contrast to these inexpensive (under \$10,000) 3D scanners, HandyScan 3D, (shown in the below) developed and marketed Creafom<sup>5</sup> from Quebec, Canada, is a handheld scanner that twin laser beams illuminating the object being scanned. The



light, by uses



reconstructed model will be visible on the computer screen in real time as the scan progresses without any user input. Trimming and aligning of the scans which is by far the most time consuming and at least for beginners the most challenging task has been eliminated in HandyScan 3D, which costs about ten times more than the previous group of scanners that makes it out of reach for most academic institutions.

As of today, there are two most widely known reverse engineering software available though many more claims the same functional ability. Rapidform<sup>6</sup> and Geomagic<sup>7</sup> are the only two software with most extensive ability to manipulate the scanned data towards recreating the original object. A version of Rapidform called RapidWorks is sold with NextEngine scanners. This software can do all the necessary steps to complete a reverse engineering project from scanning the part, cleaning the scanned data, aligning/merging the scans, patching up holes and fixing irregularities, aligning to a set of coordinate axes, creating a NURBS surface model and exporting to a CAD software, such as SolidWorks as a parametric solid or surface model. Geomagic Studio has the ability of creating NURBS surface model where as Geomagic Wrap can be used to create polygons from point cloud data and Geomagic Qualify is useful to check against dimensional accuracy. The professional version of these software cost well over \$10,000 though educational discounts are available. The RapidWorks sold exclusively for NextEngine scanners can be obtained for a little over \$2000 for academic institutions.



### Problem Definition

Albany State University (ASU) located in southwest Georgia conducts a transfer engineering program with Georgia Institute of



Technology. ASU engineering students are required to take a introductory level engineering course called “Principles of Engineering Analysis and Design” which is a prerequisite to all 2000 level engineering courses. Apart from covering all the topics normally treated in any “Introduction to Engineering” course, a three hour laboratory class is used for realistic hands-on training in Lego NXT programmable robots, CNC lathe, computer controlled wind tunnel, SolidWorks CAD software, 3D Printer, 3D scanners, and reverse engineering software. This laboratory facility which includes materials testing equipment including metallurgical microscope was established from a grant from the Department of Education with an intent to provide more realism and familiarity with current manufacturing and testing equipment at an early stage of students education.

When the 3D scanners and reverse engineering software were integrated into the laboratory curriculum<sup>8</sup>, for the first two years, students were asked to scan their teammate’s face and reconstruct that from the point cloud data with the help of reverse engineering software. One such example is shown here where the NURBS surface model has been extended with the addition of a back plate in SolidWorks. In spite of such excellent results, it proved to be a very challenging assignment for some of the student teams. First of all in order to produce a good scan, one has to hold posture and control breathing for the duration of the scan that may extend for a minute and half. Secondly, aligning scans and filling holes and removing irregularities from an organic shape such as a human face proved to be quite challenging. In order to avoid the above problems and provide the students with a positive experience where every team will be able to produce the same object with precisions, a prismatic part with geometric shapes such as cylinder, hemi-spheres, cylindrical holes etc. was chosen (see figure in the left). The part was developed in SolidWorks and prototype made in 3D Printer. Students scan this “original” part in NextEngine scanner, and then use the ScanStudioHD software to trim and align the scans, export to RapidWorks and eventually to SolidWorks to create part definition in stl format which can be printed in 3D Printer. If they follow the procedural steps accurately the final prototype will be indistinguishable from the original part.

### 3D Scanning and Reconstruction of the Model

#### Workflow Diagram

The first task for this project is to take adequate number of scans of acceptable quality making sure that there is sufficient overlap between consecutive scans. Workflow diagram for scanning and reconstruction of the model is shown here. Student laboratory manual describes each step in sufficient details for the students to feel comfortable. Brief descriptions of the steps along with the hardware and software are included here.

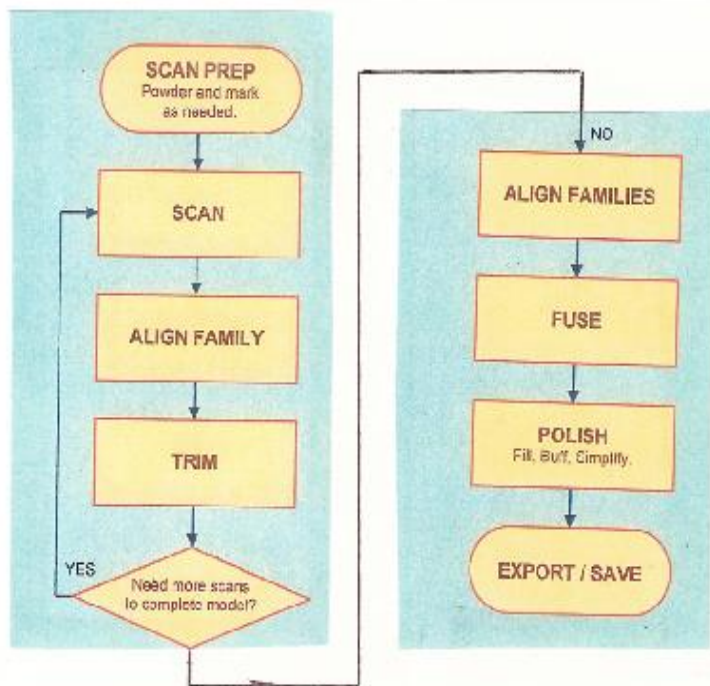
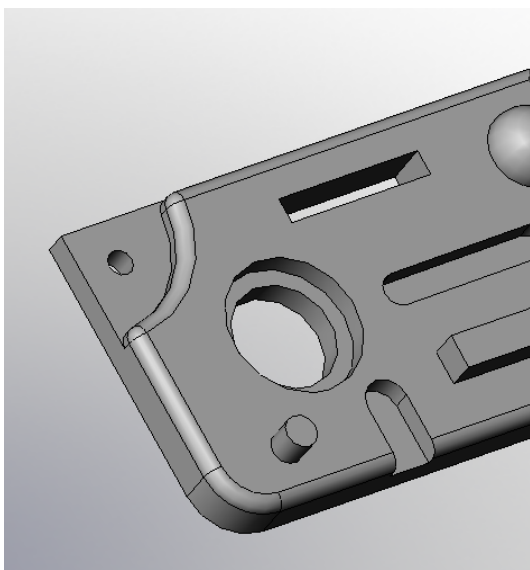


Fig  
uFi  
gur  
e 1.  
  
Wo  
rkfl

## ow Diagram

### Scanning with the NextEngine scanner

Metallic or shiny objects need to be prepped by spraying with a powder to give it a matt finish though it is not necessary for this project as the abs plastic part is made in the 3D Printer and has a natural matt finish. The scanner works for two settings of distances of the lens to the midpoint of the object, Macro mode is about 6” (right selection for this project) and wide mode is about 17”. Also, one can take 360 scans, bracket scans or single scans. Students are advised to take as many single scans as necessary to cover every part of the object making sure there is overlap between multiple scans with at least three distinguishable points in each scan which help align and merge successive scans. A minimum of eight to twelve scans are necessary to cover the entire object. It is possible to add scans even after the reconstruction process have begun.

### Reconstruction of the object via Trim, Align, Fuse and Polish tools

The procedural steps require that each scan should be cleaned of unwanted points by the trim tool manually. This requires concentration and a steady hand. Once the scans are cleaned they have to be merged by align tool. Two scans will appear in split screen with three (red, yellow, blue) balls with top right hand corner of each screen. Students have to select any of the balls and place it on a clearly distinguishable point in one scan and place the same colored ball in the other scan at the same exact point. When three sets of balls of different colors are placed in the same exact points in two scans, pressing the align button will merge the two scans. Successive scans will start appearing in split screens and the process will continue till all the scans have been merged. Application of fuse tool will fix the scans with respect to each other to reconstruct the object. Polish tool on the menu bar provides opportunity of filling holes and Buffing tool provides smoothness. Also one can clean defects under the Polish tool on the menu bar. Once all the above steps are done, the model can be exported to RapidWorks, when ScanStudio will close and the model appears in a new window in RapidWorks.

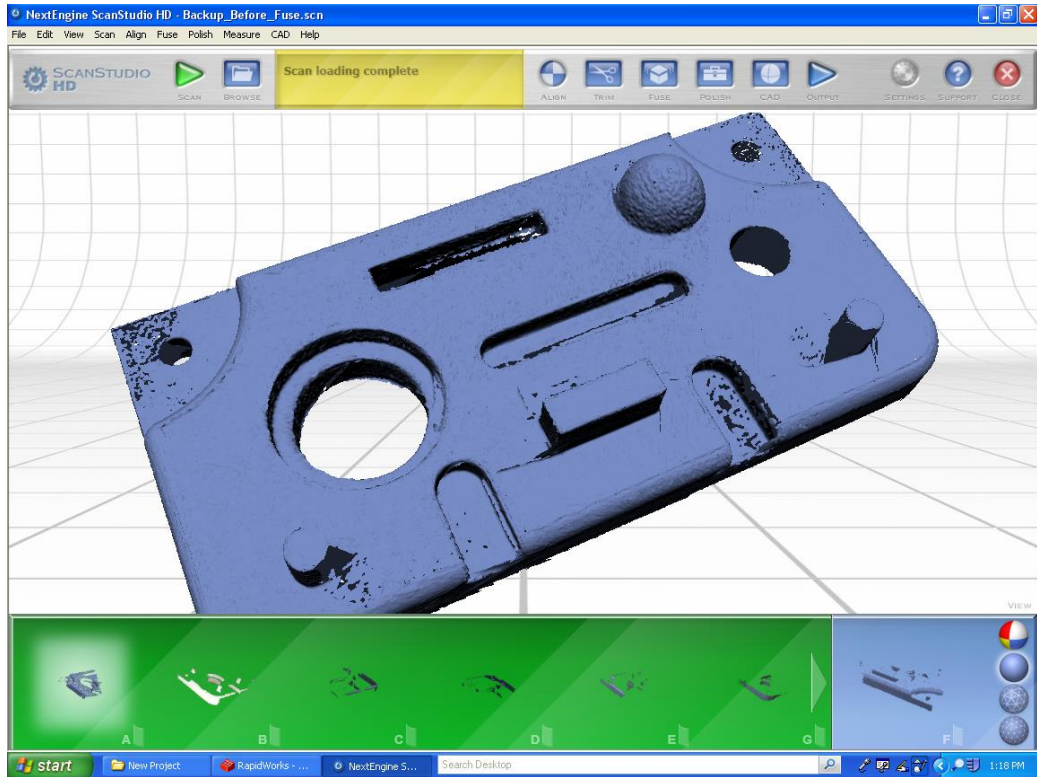


Figure 2. The screen shot above shows the aligned model before fuse and polish.  
Individual scans are shown in the film at the bottom

## Reverse Engineering

The model exported to RapidWorks still has irregularities and holes in it. It is possible to fill holes and smooth the surface one part at a time. It will be more time consuming and the final product will not resemble the original part in smoothness and finish. Instead the approach adopted here is to trace the external boundary of the part and recognize the primitives such as circular arcs, hemi-sphere, rectangular or circular hole. The model is then recreated one item at a time.

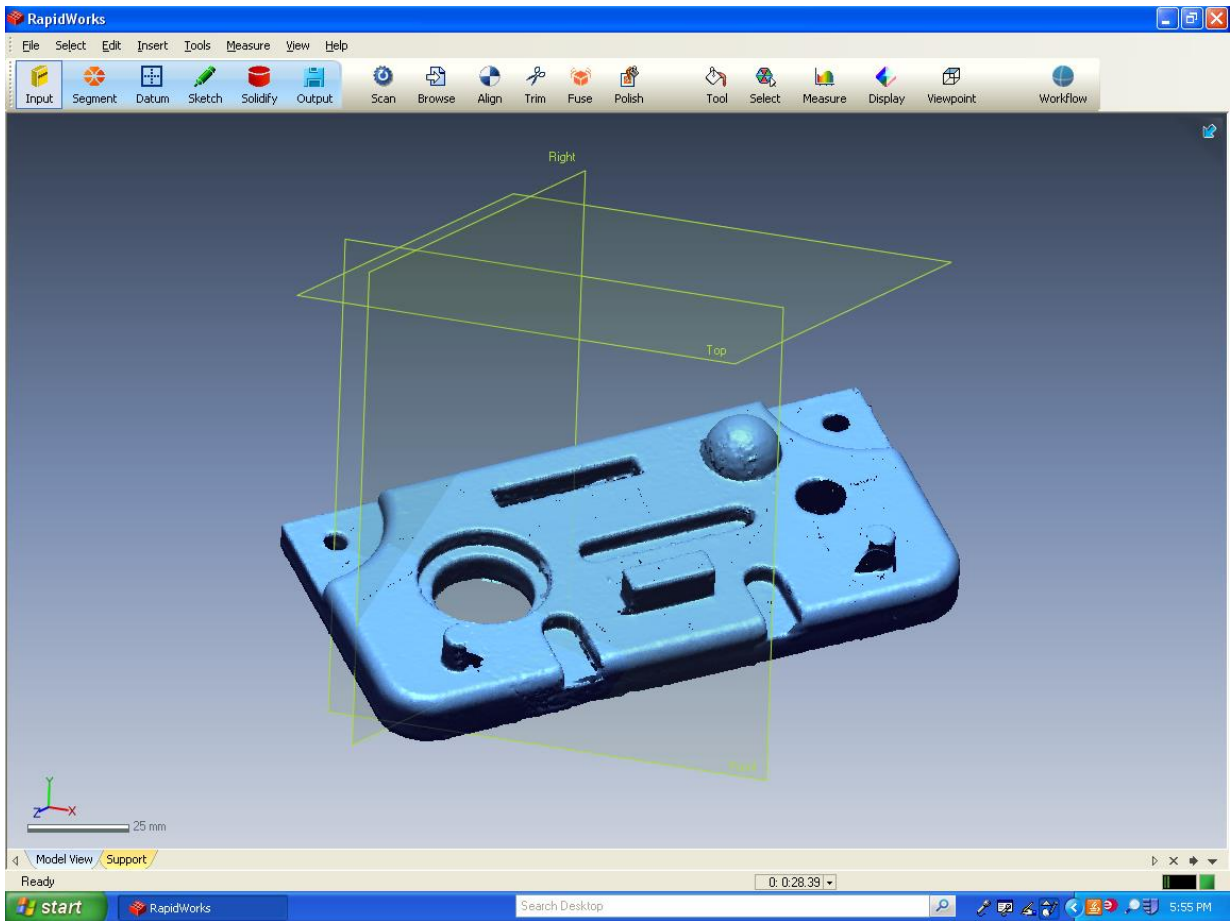


Figure 3. Scanned Model opened in RapidWorks as exported by ScanStudioHD software.

Note: The model at this stage is not aligned with the orthographic planes

In order to achieve this, one has to first go through mesh alignment, which refers to autosegmenting and then creating 3 reference planes through one or more planes of the model such that they are perpendicular to each other. Then these 3 planes which are attached to the model surfaces are interactively aligned to the front, top and right planes of the standard coordinate system. Model orientation will then correspond to the principal planes in RapidWorks as well as when exported to CAD software such as SolidWorks. Next for modeling the part, the outline is sketched with a line tool. Other tools such as trim tool, fillet tool are also used. Then each primitive is recognized one at a time by “extract specific shape” tool. Then with “extrude” and “cut” and other tools, various Boolean operations are performed. If all the steps are properly done the model should look like an exact copy of the original part.

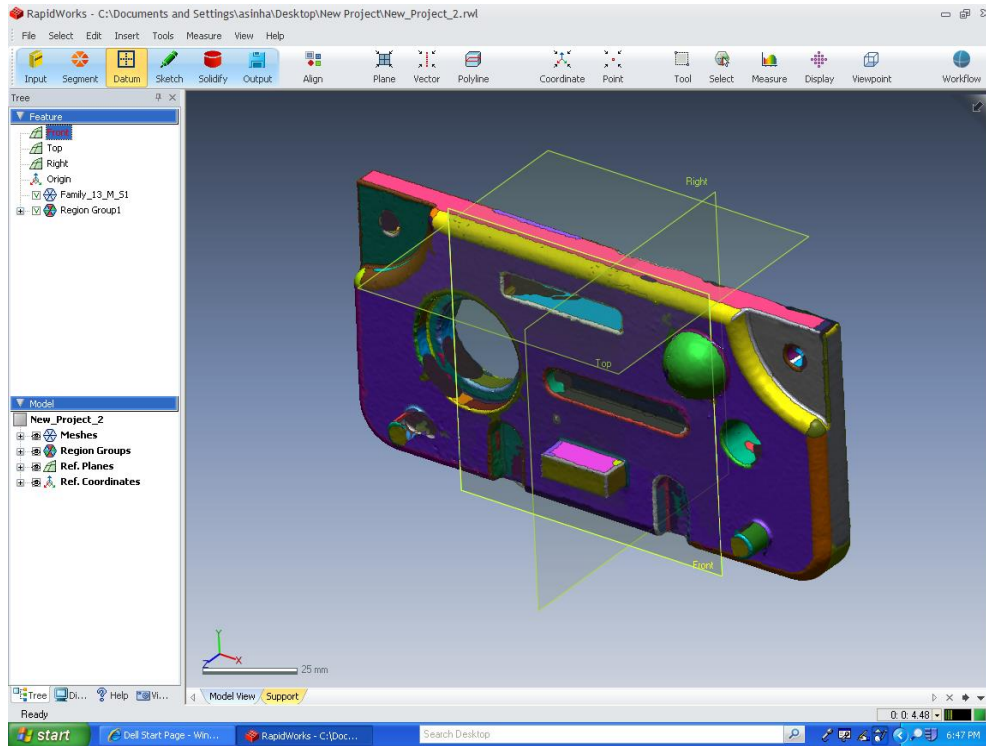


Figure 4. Model after aligned with the global coordinate axes

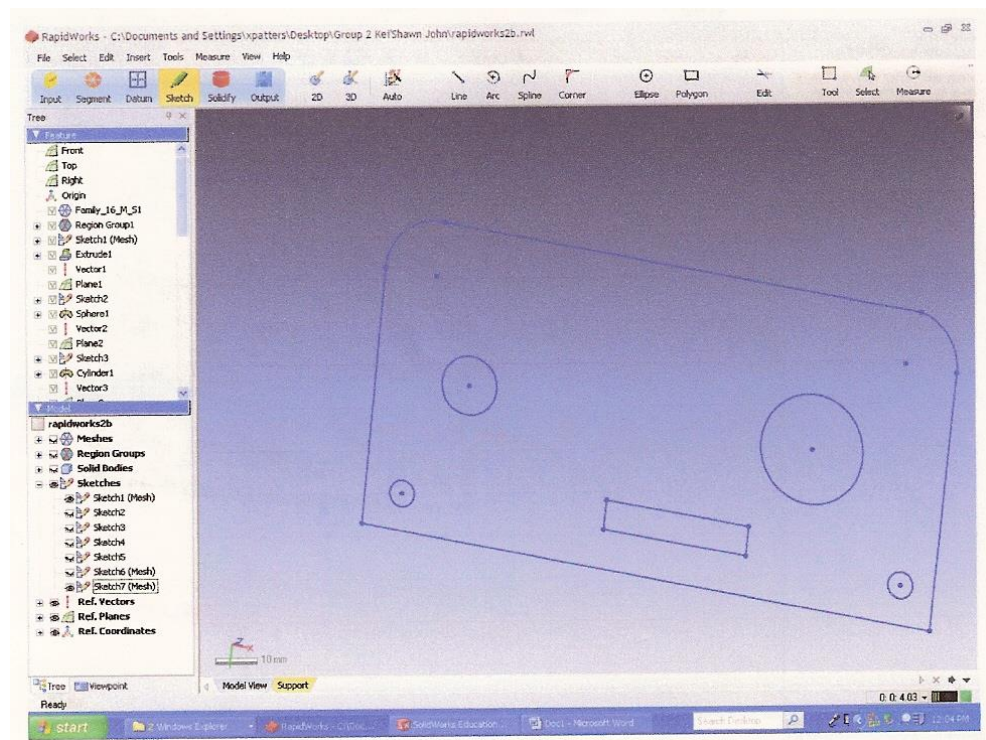
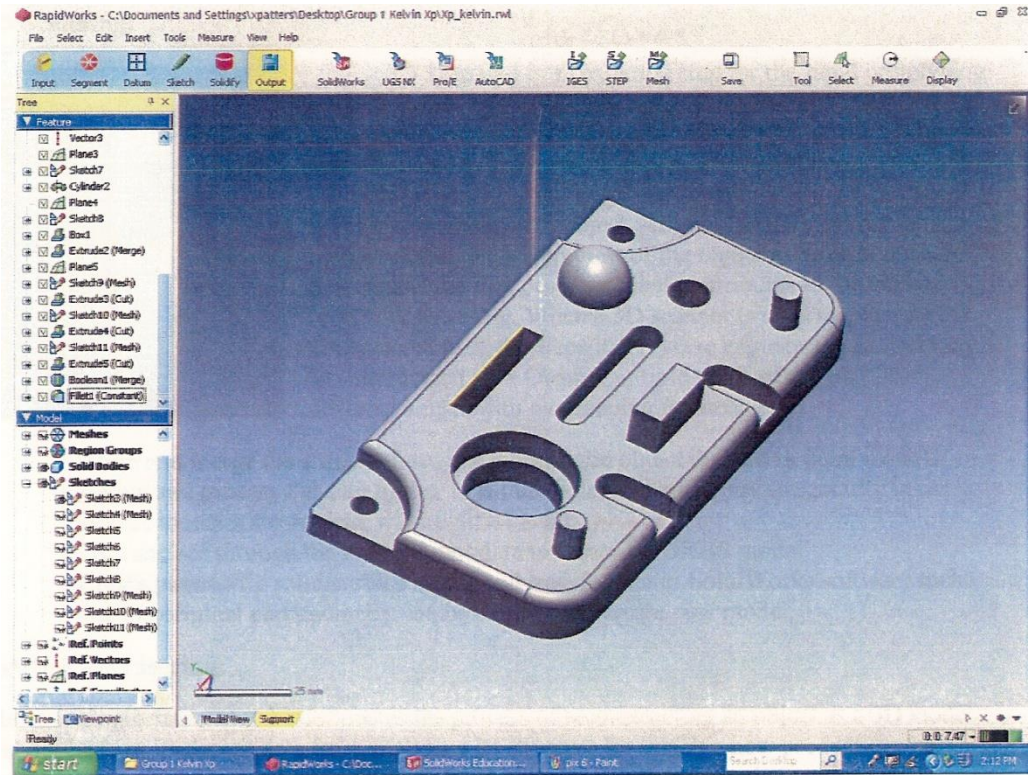


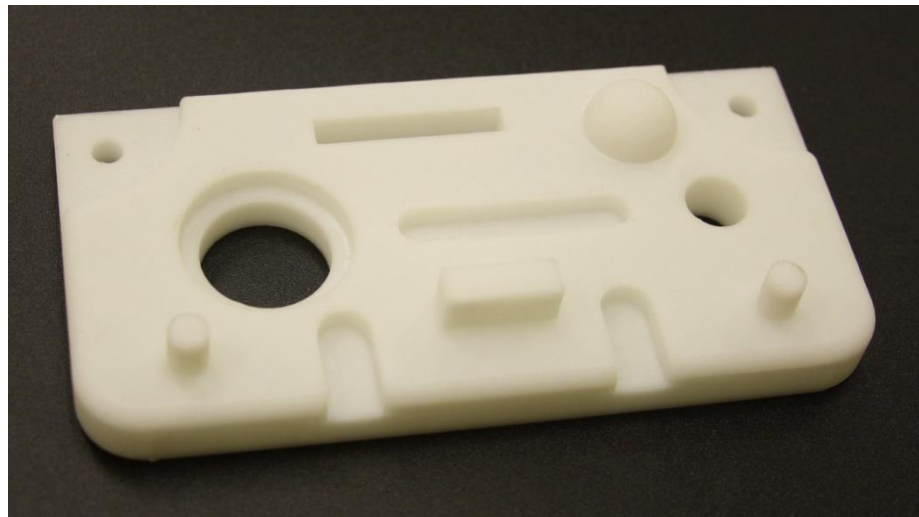
Figure 5. The model outline is sketched with sketch tools



**Figure 6. The completed model appears in RapidWorks**

### **Building the Prototype**

Finally the part can be exported to SolidWorks where it will appear as a native parametric SolidWorks model. The model's original design can be extended in SolidWorks if desired. In the last step, prototype may be made in a 3D printer by first saving the model in \*.stl format and processed by Catalyst software.



**Figure 7. Final Step: The prototype- should be an identical copy of the original**

### **Conclusion**

The step by step instructions for the project outlined above has now been included in the laboratory manual for the “Principles of Engineering Analysis and Design” introductory engineering course starting fall 2011 semester though students were doing this project for the last two years. In general, students work in teams of two. As we only have two sets of scanners and reverse engineering software, students have to take turn to work on their project. Also, because of the amount of time required (about 10 hours or more) to complete the project, by and large student teams have to work outside the normal two and half hour weekly slot for the laboratory class. This sometime requires some of the students work in the weekends though this normally did not produce any tension. This project really excites student’s imagination and makes them do their best. In last year’s survey questionnaire, in response to the question to describe students’ perception of the 3D scanning and reverse engineering project in a scale of 1 to 10, 1 being very negative and 10 being very positive, average was 8. A few students gave it a full 10 points. All students mentioned that despite the fact that they liked the 3D scanning/reverse engineering project, they are not happy with the amount of time (about 3 weeks) allotted for this project. They were also uncomfortable because of lack of a written lab manual as RapidWorks is extremely complex software. We have taken care of the lab manual issue and will allow them more time this year so that they will not be rushed to complete the project. Based on the past four years of experience it is safe to say that the 3D scanning/reverse engineering/rapid prototyping project will continue to motivate our students towards an exciting engineering career in the coming years.

## **Bibliography**

1. Grimm, T., “User Guide to Rapid Prototyping,” Society of Manufacturing Engineers, 2004
2. Stratasys, Inc., <http://www.stratasys.com>
3. NextEngine Inc., <http://www.nextengine.com>
4. 3D Digital Corporation, <http://www.3ddigitalcorp.com>
5. Creaform, <http://www.creaform3d.com>
6. Rapidform Global Headquarters, INIUS Technology, Inc., <http://www.rapidform.com>
7. Geomagic <http://www.geomagic.com>
8. Sinha, A., “AC 2009-514: Integrating Reverse Engineering Project in A Laboratory Based Introductory Engineering Course,” Proceedings of the 2009 ASEE Conference and Exposition held in Austin, TX.

**Building Affordable High Performance Computing Platforms for  
Engineering Education**

Yili Tseng

Department of Electronics, Computer, and Information Technology

North Carolina A & T State University

Greensboro, NC 27411, U.S.A.

E-mail: [ytseng@ieee.org](mailto:ytseng@ieee.org)

**YILI TSENG**

Yili Tseng received the PhD degree in computer engineering from the University of Central Florida. He is currently an Associate Professor and the advisor of the Computational Technology Concentration in the Department of Electronics, Computer, and Information Technology at North Carolina Agricultural and Technical State University. He published several research papers in internationally recognized journals and conferences, including IEEE Transactions on Parallel and Distributed Systems and Parallel Computing. His research interests include high-performance computing, grid computing, and cloud computing.



# Building Affordable High Performance Computing Platforms for Engineering Education

Yili Tseng

Department of Electronics, Computer, and Information Technology  
North Carolina A & T State University  
Greensboro, NC 27411, U.S.A.  
E-mail: ytseng@ieee.org

**Abstract** - Traditionally, engineering and science disciplines have relied on observation, theory, and experimentation as tools to perform research to explore new knowledge. With the introduction of computer hardware and software, numerical simulation based on mathematical modeling gradually becomes an important tool. After high performance computers are mature and commercially available, numerical simulation has become a tool as important as observation, theory, and experimentation to all engineering and science disciplines. In most cases, it is adopted more often than experimentation because it is more economic, less time-consuming, and able to explore infeasible situations. Without doubts, numerical simulation should be included by engineering education. Numerical simulation depends on high performance computers. High performance computers refer to parallel computers, namely computers equipped with multiple processors. However, the largest barrier to high performance computing education is the high cost of high performance computers. Most institutions cannot afford expensive parallel computers. The author explored and managed to discover three options of affordable platforms suitable for high performance computing classes. The first platform is personal computers equipped with multi-core processors and thread libraries. The second platform is PCs equipped with Graphic Processing Unit cards. The third platform is commodity clusters consisting of inexpensive PCs and network switches. They even can be built with retired PCs. All three approaches provide low-cost solutions for all institutions to offer their high-performance computing education.

## 1. Introduction

Traditionally, engineering and science disciplines have relied on observation, theory, and experimentation as tools to perform research to explore new knowledge. With the introduction of computer hardware and software, numerical simulation based on mathematical modeling gradually becomes an important tool. [1][2] Most engineering and science disciplines develop numerical modeling for simulations in their respective fields. [1][2][3] After high performance computers are mature and commercially available, numerical simulation has become a tool as important as observation, theory, and experimentation to all engineering and science disciplines. In most cases, it is adopted more often than experimentation because it is more economic, less time-consuming, and able to explore infeasible situations. [1][2] Without doubts, numerical simulation should be included by engineering education. Numerical simulation depends on high performance computers to solve large scale problems or effectively improve accuracy of results because they surpass the computing power of uniprocessor computer system. High performance computers refer to parallel computers, namely computers equipped with multiple processors. [3][19][20][22] Although parallel computers are capable to execute sequential programs, but only one processor is being utilized while other processors sitting idle. Parallel programs have to be written and executed to take advantage of all processors in a high performance computer. Therefore, introductory high performance computing and parallel programming courses should be covered by engineering education as well. Another rationale which makes both courses imperative for engineering education is explained as follows. Since 2003, the speed of uniprocessors can hardly be

pushed because of energy-consumption and heat-dissipation problems. [3] That is why the major processor manufacturers such as Intel and AMD introduce multi-core processors instead of uniprocessors with faster clock cycle since then. Just like multiprocessor computers, parallel programs have to be executed to take advantage of all cores of a multi-core processor. Both phenomena push the need for high performance computing education to be part of engineering education as engineering applications heavily depend on computation.

However, the largest barrier to high performance computing education is the high cost of high performance computers. Most institutions cannot afford expensive parallel computers. Even if a university owns few high performance computers, they are always reserved for research and would not be used for teaching and learning because they are precious. That is the case at the author's institution. In order to find affordable platforms for his high performance computing classes, the author explored and managed to discover three options of affordable platforms suitable for high performance computing classes. The first platform is personal computers (PCs) equipped with multi-core processors and thread libraries. The second platform is PCs equipped with Graphic Processing Unit (GPU) cards. The third platform is commodity clusters consisting of inexpensive PCs and network switches. They even can be built with retired PCs. All three approaches provide low-cost solutions for all institutions to offer their high-performance computing education. They will be presented in this paper so that any institution can select the option which fits their affordability and deploy high performance computing platforms with the minimal costs.

## **2. Multi-core Processors and Threading Libraries**

The easiest way to start parallel processing is to carry out multithreaded programs on multi-core PCs. No extra hardware needs to be added except multithreading libraries needed to be installed. Most multithreading libraries are free. Although multithreaded programs can be executed on uniprocessor PCs, parallelism from multithreading would not make any performance gain because all threads are executed sequentially by a single uniprocessor. Fortunately, multi-core PCs are very affordable these days. The current drawback is that all threads can only be executed on the cores of the same chip. Consequently, only small scale multithreaded programs can be executed because not many cores can be incorporated into a chip by current technology. Nonetheless, considering many-core processors with 32 or 48 cores are being rigorously tested, multithreaded programs will be able to carry out large scale parallel applications soon. It is still worthy to starting teaching multithreading programming. The popular threading libraries and concurrent programming languages are introduced in following subsections.

### **2.1 Intel Threading Building Block**

Intel Threading Building Block (TBB) is the newest threading library which supports C++. [15] It is downloadable at <http://threadingbuildingblocks.org> for free. It targets to provide high-level parallelism in contrast to low-level parallelism offered by raw threads libraries and Message Passing Interface (MPI). Issues like optimal management of a thread pool, proper distribution of task with load balancing, and cache affinity are automatically taken care of by TBB. Therefore, it is easier for beginning parallel programmers in addition to better performance than the alternatives.

### **2.2 POSIX Threads**

POSIX (Portable Operating System Interface) Threads (Pthreads) is a threading library for C++ as well. It has been existing for more a decade and was the most popular threads library in the past. Hence, more documentations and textbooks are available for Pthreads. [13][14][16]

### 2.3 Microsoft Windows Threads

Microsoft Windows Threads is a threading library supporting C++ for Microsoft Windows operating systems. It is included in Microsoft Windows SDK. Some programmers prefer it to Pthreads because of the simplicity of use. [24]

### 2.4 Threads in Java and C# and Tasks in Ada

Java, C#, and Ada are concurrent programming languages which directly support concurrency without having to use API. [17] The concurrent activities are called threads in Java [17][18][21] and C# [23] while called tasks in Ada. Different thread and tasks can be executed in parallel on different cores of a multi-core processor.

## 3. GPU-equipped Personal Computers

Compute Unified Device Architecture (CUDA) is an architecture developed by NVIDIA for its GPUs. [27][28][29] CUDA adopts many-core approach which has numerous much smaller cores than the cores of a multi-core CPU. The massive GPU cores are optimized for floating-point calculations while the CPU cores are optimized for sequential code execution. [28] Engineering applications rely heavily on floating-point calculations. CUDA can place much more cores in a chip than multi-core CPUs. That makes it more powerful than multi-core CPUs in floating-point calculations as much more cores are dedicated to the purpose. In 2009, the ratio for peak floating-point calculation throughput between many-core GPU and multi-core CPU is about 10 to 1. [28] The Chinese Tienhe-1A supercomputer took the title of fastest supercomputer in the world from American Jaguar supercomputer in November 2011 with 37794 less CPU cores by adopting GPUs. GPUs' design philosophy also makes them cheaper than multi-core CPUs. Table. 1 lists the numbers of GPU cores and costs of four different GPU cards. The numbers of CPU cores and costs of three different CPUs are shown in Table 2. Those prices as of October 2011 were found on [www.pricewatch.com](http://www.pricewatch.com). Apparently, the cost/performance ratio of GPUs is much better than that of multi-core CPUs. The programming language is CUDA C/C++ which is based on C/C++. Lots of computational scientists and researchers are adopting GPU programming because it is very cost-effective. Therefore, GPU computing is very promising and should be covered in engineering education.

Model	Number of GPU Cores	Price
GeForce 210	16	\$35
GeForce GT 430	96	\$60
GeForce GTX 460	336	\$149
GeForce GTX 580	512	\$460

Table. 1 Features and Costs of GPU

Model	Number of CPU Cores	Price
Intel Core i7 3.06GHz	4	\$297
AMD Phenom II X6 3GHz	6	\$169
AMD Phenom II X4 3GHz	4	\$120

Table. 2 Features and Costs of CPU

With the low-costs of GPUs, PCs equipped with GPU cards are affordable for any institution. The CUDA library and compiler is provided by NVIDIA for free for Linux, Windows, and MacOS. All software required for GPU programming is free if Linux platform is adopted.

### **3.1 Hardware Requirement**

Any graphic card equipped with NVIDIA GPU can be utilized. GPU Device drivers have to be installed and can be downloaded from [www.nvidia.com](http://www.nvidia.com). [27]

### **3.2 Software Requirement**

The software required for GPU programming is C compiler for GPU and C compiler for CPU. The GPU compiler is contained in CUDA Development Toolkit which is freely downloadable at NVIDIA's web site. [27] The GNU C compiler coming with Linux can be used as the compiler for CPU without charge.

## **4. Commodity Clusters**

C/C++ and FORTRAN has dominated the numerical methods field, a key part of computational science, for decades and numerous of programs were coded in both languages. It is beneficial to stick with both languages and reuse existing codes and libraries. Message Passing Interface (MPI) is a standard developed for parallel libraries supporting C/C++ and FORTRAN.[1][2][3][10] [25][26] Several MPI implementation has been developed for different platforms. MPI programs are portable among those platforms. Message-passing clusters are the most popular high performance computers. Students learning MPI programming from small-scale commodity clusters can easily adapt to large-scale high performance clusters. Thanks to the contribution of open-source software developers, MPI libraries have been successfully ported to inexpensive PC platform. Along with other free open-source operating systems and applications for PC, they can make PCs networked by low-cost switches a commodity cluster, an affordable platform for high performance computing education. With clusters built with the retired PCs and free software, any institution can own its platforms with minimal cost and start high performance computing education. Although clusters built with retired PCs do not have sufficient computing power to execute large-scale parallel applications, they do exhibit all characteristic of parallel processing and can execute qualitative experiments. If an institution owns sufficient funding, it can acquire high-end PCs and construct a cluster which has decent computing power to execute serious parallel programs for research. While an affordable cluster can be built with the free open-source software and retired PCs, it cannot work practically without some vital configurations. Several books have been written about building a cluster with Linux. [4][5][6][7][8] However, all of them fail to point out the vital configurations required to make the cluster work correctly. The practical issues in building an inexpensive cluster are addressed in the following subsections respectively.

### **4.1 Hardware Requirements**

Any PC with 128B RAM or more and an Ethernet network interface card (NIC) can work as a node. PCs with Pentium III 500MHz CPUs work smoothly at author's institution. All nodes have to be connected with a network switch. Generic Ethernet NICs and switches can be acquired with very little cost. The logical layout is shown in Figure 1 and a 10-node commodity cluster is displayed in Figure 2.

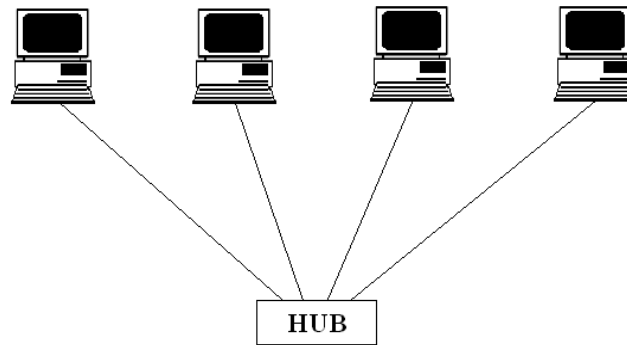


Fig. 1 Logical layout of a commodity cluster



Fig. 2 A 10-node commodity cluster built of retired PCs

## 4.2 Operating System and Software Packages

Among all operating systems, only Linux can be acquired for free. Also, Linux operating systems come with plenty of hardware drivers which cover almost all legacy and new hardware, that further makes it the ideal OS for commodity clusters. Although several implementations of open source Linux operating systems are available, not all of them work well with the MPI library. After extensive experiments, the author chose and installed CentOS Linux which is a clone of commercial Red Hat Enterprise Linux [11] and downloadable at [www.centos.org](http://www.centos.org). The following actions should be done for all nodes in the cluster. Firewall and SELinux should be turned off during installation as they cause difficulty for communications among nodes which are required for executing MPI programs. Fortunately, security is not a concern as long as the cluster is not connected with other networks. The editor, GNU C++ and FORTRAN compilers under “Development Tools” have to be installed to as they are required for MPI programming process. One node should be selected as the server node and the following software should be installed on the node during installation: Network Information Service (NIS) server under “Network Server” and Network File System (NFS) server configuration tool under “Server Configuration Tool.” After Linux is installed, networking should be correctly configured so that all nodes of the cluster can communicate among one another. In general, one user account with the same name needs to be created on each node because a parallel program is dispatched to each node under the same user account. NIS which is addressed in later subsections can take care of this and other issues.

### 4.3 MPI library

The next major step is to install the MPI library. Again, there are several free implementations of MPI, such as MPICH, LAM/MPI, Open MPI, etc. Nevertheless, only Open MPI is still under active development and growing more powerful. [9] Therefore, Open MPI is the best choice. The steps to install Open MPI are quite straightforward. They are described as follows. First, download the latest version of the library from Open MPI's website, [www.openmpi.org](http://www.openmpi.org). Log into the root account to install it. Copy the compressed file to the /tmp directory. Uncompress the file by double clicking the file icon to uncompress the library. Then change to the directory openmpi-1.4.3. Configure and make Open MPI with the commands below. [9] Replace the directory after prefix option if you want to install into another directory. The make process may take up to one hour on an old PC.

```
shell$ ./configure - -prefix=/usr/local
shell$ make all install
```

### 4.4 Need for NFS and NIS

Before we run a parallel program on our cluster, we need to dispatch a copy of the program's executable file onto every node under the same account. Manually copying the executable to all nodes is impractical. Network File System (NFS) is the solution to this requirement. With NFS, the program's executables only need to be saved into the shared directory of the NFS and a copy of the program will be automatically copied to all other nodes. It is also impractical to create accounts for all users on all nodes. To remedy this problem, Network Information System (NIS) is used to create accounts on the server node. After all nodes are configured as NIS clients, all users can login from any node and run their own parallel programs. You have to login as root to perform all following setups and reboot all nodes to take effect. Do not reboot any client node until the server node completes its boot-up process, otherwise client nodes cannot read the correct configuration information from the server and perform normally.

### 4.5 Set Up the NFS Server [11]

- 1) From the *NFS Server Configuration* window, click *File* → *Add Share*. The *Add NFS Share* window appears. In the *Add NFS Share* window Basic tab, type the following information:
  - Directory – Type the name of the directory you want to share. Type “/home” which is the parent directory to all user directories.
  - Host(s) – Enter one or more host names to indicate which hosts can access the shared directory. Type “\*” to let all nodes access NFS server.
  - Basic permissions – Click *Read/Write* to let remote computers mount the shared directory with read/write access.
- 2) To permanently turn on the NFS service, type:

```
shell$ chkconfig nfs on
shell$ chkconfig nfslock on
```

### 4.6 Set Up the NFS Client [11]

To set up an NFS file system to mount automatically each time you start your Linux system, you need to add an entry for that NFS file system to the /etc/fstab file. The /etc/fstab file contains information about all different kinds of mounted file systems for your Linux system. The format for adding an NFS file system to your local system is the following:

```
host:directory mountpoint options 0 0
```

The first item identifies the NFS server computer and shared directory. Mountpoint is the local mount point on which the NFS directory is mounted, followed by the file system type `nfs`. Any options related to the mount appear next in a comma separated list. For our system, we add the following NFS entries to `/etc/fstab`:

```
kingtiger1:/home /home nfs rsize=8192,wsiz=8192 0
```

#### 4.7 Set Up the NIS Client [11][12]

All nodes have to be configured as NIS clients by the following steps. Even the NIS server has to be set up as an NIS client first.

1) Defining an NIS domain name:

To make the NIS domain name permanent, you need to have the `domainname` command run automatically each time your system boots. It can be done by adding the command line to a run-level script that runs before the `ybind` daemon is started. The following line should be added just after the first set of comment lines in the `/etc/init.d/network` file.

```
domainname kingtiger
```

2) Setting up the `/etc/yp.conf` file:

We have an NIS domain called `kingtiger` and a server named `kingtiger1`, the following entries are added in the `/etc/yp.conf` file:

```
domain kingtiger server kingtiger1
```

```
domain kingtiger broadcast
```

```
ypserver kingtiger1
```

3) Configuring NIS client daemons:

We need set up an existing run-level script called `ybind` to start automatically at boot time. To do this, run the following command:

```
shell$ chkconfig ybind on
```

4) Using NIS maps:

For the information being distributed by the NIS server to be used by the NIS clients, you must configure the `/etc/nsswitch.conf` file to include `nis` in the search path for each file you want to use. In most cases, the local files (files) are checked first, followed by `nis`. The following are examples of how some entries should be changed:

```
passwd: files nis
```

```
shadow: files nis
```

```
group: files nis
```

```
hosts: files nis dns
```

#### 4.8 Set Up the NIS Server [11][12]

1) To configure your Linux system as an NIS server, you should first configure it as an NIS client and reboot the system.

2) Creating NIS maps:

To create NIS maps so that your Linux system can be an NIS server, start from the `/var/yp` directory from a Terminal window as root user. In that directory, a `Makefile` enables you to configure which files are being shared with NIS. All default configurations in `Makefile` are ok for our purposes, so we don't need change them.

3) Configuring access to maps:

In the `/etc/ypserv.conf` file, you can define rules regarding which client host computers have access to which maps. For our purposes we just need add the following line into `/etc/ypserv.conf` to allow all hosts access to all maps:

```
* : * : * : none
```

#### 4) Configuring NIS server daemons:

We can use the following `chkconfig` command to set `ypserv` and `yppasswdd` scripts to start automatically at boot time.

```
shell$ chkconfig ypserv on
```

```
shell$ chkconfig yppasswdd on
```

#### 5) Updating the NIS maps:

If you modify the sources for NIS maps (for example if you create a new user by adding the account to the `passwd` file), you need to regenerate the NIS maps. This is done by a simple

```
make -C /var/yp
```

This command will check which sources have changed, creates the maps new and tell `ypserv` that the maps have changed.

### 4.9 Disabling Password Authentication

As Open MPI is configured by default to use `ssh` (secured shell) to dispatch parallel tasks, it is `ssh` that asks for password to authenticate the connection. Extra steps below will prevent `ssh` from requesting passwords [9]. Because the measure should only work for the user account which intends to run MPI applications, log into the specific user account instead of root account to configure. First, generate the private and public key for the user account by executing:

```
shell$ ssh-keygen -t dsa
```

That will generate the hidden `.ssh` directory with the necessary attribute. Change into the `.ssh` directory and do the following. [9]

```
shell$ cp id_dsa.pub authorized_keys
```

With these procedures done, the public keys are duplicated as the authorized keys. They will be used for authentication for all future connections without passwords being requested from other nodes. Now the MPI applications can be executed on multiple nodes of this cluster without being asked for passwords.

### 5. Conclusion

With the maturity and availability of high performance computers, numerical simulation has surpassed experimentation and become the most important tools for research and design as it is very cost effective. Most engineering applications utilize numerical simulation to resolve problems. In turn, the efficiency of numerical simulation depends on high performance computing. That fact necessitates engineering education to cover high performance computing. As the development of processors has shifted to multi-core approach, parallel programming becomes imperative to take advantage of the extra cores of modern CPUs. Likewise, that demands the inclusion of parallel programming in engineering education. Nonetheless, the challenge for most institutions to offer both topics in engineering education is the high cost of high performance computers. The author explored and managed to discover three approaches to build affordable high performance computing platforms for high performance computing education. The first approach is to adopt PCs equipped with multi-core processors and install multithreading libraries. Multithreaded programs which exhibit parallelism can be executed on all cores of the multi-core processor. Students can learn parallel programming through writing the multithreading programs. This approach does not require any extra hardware or configuration to build the high performance computing platform. The second approach is to adopt the emerging GPU programming by acquiring PCs equipped with inexpensive GPU cards. This approach requiring only insertion of GPU cards into the PCI



Express slots in the PCs and installation of software drivers. The third approach is to build commodity cluster with PCs and network switches. This approach needs some system configurations which are all described in this paper. As retired PCs can be used and all required software can be downloaded for free, this approach is the cheapest way to build high performance computing platforms. While the three approaches may not have the computing power to carry out large scale parallel applications, all of them exhibit full features of parallel systems and applications. Hence, they are ideal for teaching high performance computing in engineering education.

## References

- [1] Quinn, Michael J., **Parallel Programming in C with MPI and OpenMP**, McGraw Hill, 2004
- [2] Karniadakis, George and Kirby, Robert, **Parallel Scientific Computing in C++ and MPI**, Cambridge University Press, 2003
- [3] Grama, Ananth et al., **Introduction to Parallel Computing**, Addison-Wesley, 2003
- [4] Sloan, Joseph D., **High Performance Linux Clusters**, O'Reilly, 2005
- [5] Bookman, Charles, **Linux Clustering**, New Riders, 2003
- [6] Vrenios, Alex, **Linux Cluster Architecture**, Sams, 2002
- [7] Lucke, Robert, **Building Clustered Linux Systems**, 2005
- [8] Gropp, William et al., **Beowulf Cluster Computing with Linux**, 2<sup>nd</sup> Ed., MIT Press, 2003
- [9] [www.openmpi.org](http://www.openmpi.org) FAQ
- [10] Pacheco, Peter S., **Parallel Programming with MPI**, Morgan Kaufmann Publishers, Inc. 1997
- [11] Sobell, Mark, **A Practical Guide to Red Hat Linux**, Third Edition, Prentice-Hall, 2006
- [12] <http://www.linux-nis.org/nis-howto/>
- [13] Hughes, C. and Hughes, T., **Professional Multicore Programming**, Wiley, 2008
- [14] Hughes, C. and Hughes, T., **Parallel and Distributed Programming Using C++**, Addison-Wesley, 2004
- [15] Reinders, James, **Intel Threading Building Blocks**, O'Reilly, 2007
- [16] Nichols, B. et al., **Pthreads Programming**, O'Reilly, 1996
- [17] Welling, A., **Concurrent and Real-Time Programming in Java**, Wiley, 2004
- [18] Breshears, C., **The Art of Concurrency**, O'Reilly, 2009
- [19] Parhami, B., **Introduction to Parallel Processing**, Plenum, 1999
- [20] Buyya, R., **High Performance Cluster Computing**, Vol. 2, Prentice-Hall, 1999
- [21] Magee, J. and Kramer, J., **Concurrency**, Wiley, 2006
- [22] Yang, L. and Guo, M., **High-Performance Computing**, Wiley, 2006
- [23] Arora, G. et al., **Microsoft C# Professional Projects**, Premier, 2002
- [24] <http://software.intel.com/en-us/blogs/2006/10/19/why-windows-threads-are-better-than-posix-threads/>
- [25] Gropp, W. et al., **Using MPI**, MIT Press, 1999
- [26] Gropp, W. et al., **Using MPI-2**, MIT Press, 1999
- [27] Sanders, J. and Kandrot, E., **CUDA by Example**, Addison-Wesley, 2011,
- [28] Kirk, D. and Hwu, W., **Programming Massively Parallel Processors**, Morgan Kaufmann, 2010
- [29] Hwu, W., **GPU Computing Gems Emerald Edition**, Morgan Kaufmann, 2011
- [30] [www.top500.org](http://www.top500.org)

**Introducing High School Students to Engineering Fundamentals by Four Weeks Engineering Innovation Summer Program**

Pawan Tyagi  
Civil and Mechanical Engineering,  
University of the District of Columbia,  
Washington DC-20008

Christine Newman  
Center for Educational Outreach,  
Whiting School of Engineering,  
Johns Hopkins University,  
Baltimore MD 21218

## **Introducing High School Students to Engineering Fundamentals by Four Weeks Long Engineering Innovation Summer Program**

**Abstract:** Preparing high school students for engineering disciplines is crucial for the sustainable scientific and technological developments in the USA. This paper discusses a precollege program, which not only exposes students to various engineering disciplines but also enables them to consider engineering as their profession. The four-week long “Engineering Innovation (EI)” course is offered every year to high school students by the Center for Educational Outreach, Whiting School of Engineering, Johns Hopkins University. The EI program is designed to develop problem-solving skills through extensive hands on engineering experiments and projects. A team consisting of an instructor, generally a PhD in Engineering, and a teaching fellow, generally a high school science teacher, closely work with students to pedagogically inculcate basics of core engineering disciplines such as civil, mechanical, electrical, materials, and chemical engineering. EI values independent problem-solving skills and simultaneously promotes team spirit among students. A number of crucial engineering aspects such as professional ethics, communication, technical writing, and understanding of common engineering principles are instilled in high school students via well-designed individual and group activities. This paper discusses the model of the EI program and its impact on students learning and their preparation for the engineering career.

**Introduction:** Shortage of engineering students threatens US's role as world's leading innovator.<sup>1</sup> According to CNN news unprepared college students entering in science, engineering, and mathematics drop out after their first year itself. The alarming percentage of dropout is around 20%.<sup>2</sup> Engineering workforce in American industries will need an unprecedented number of engineers in near future to remain competitive and to advance cutting-edge scientific development.<sup>1</sup> To produce a large number of highly skilled engineering graduates it is crucial to make the high school students interested and prepared in the engineering disciplines.<sup>1,3</sup> Early exposure of engineering disciplines provides unique opportunity for the high school students to evaluate engineering profession as a future career.<sup>4</sup> In addition to early engineering exposure, a more practical aspect of attending an introductory engineering program may be to earn college credits from Johns Hopkins University (JHU). College credits have three utilities: (a) enhances the student's college application, (b) makes college education more affordable, and (c) reduces the course load in the initial year and allows the student to settle into college at a convenient pace.<sup>5,6</sup> At present there are a large number of introductory engineering programs, however, rarely are these programs ABET accredited and provide transferable college credits to high school students. On the other hand there are a vast number of courses at community colleges and universities, which allow high school students to earn college credits by attending specific courses; however, such courses are not specifically designed for high school students. Moreover, such courses often do not give fundamental understanding about engineering disciplines to high school students via rigorous experimental approaches or hands on experience.

Introductory engineering programs for the high school students vary dramatically in their content and nature of instruction. Some of the popular engineering introduction programs are iD Tech camps, NASA SHARP program, National Youth Science Camp, Student Materials Camp, introduction to engineering program at University of Notre Dame etc. Most of the existing programs, which serve as the bridge between high school and college programs in engineering, have the following shortcomings.

- (1) Highly specific to an engineering topic, or too generic to give a critical level of understanding about engineering basics.
- (2) Less emphasis on engineering fundamentals, more emphasis on demonstrations
- (3) Instructors are generally skilled in one engineering branch and do not have sufficiently clear understanding about other engineering disciplines, to incite genuine interest in other areas. For instance an instructor with electrical engineering background is highly unlikely to teach the concepts of civil engineering.

To overcome the above stated shortcomings, the Center for Educational Outreach at the Whiting School of Engineering at the Johns Hopkins University offers Engineering Innovation (EI) for high school students.<sup>7</sup> EI is a four week long summer program that exposes high school students to major engineering disciplines like mechanical, civil, chemical, electrical, and materials. EI is a condensed version of *EN.500.110 What is Engineering?* This course was designed by Dr. Micheal Karweit for the students with undecided engineering major at JHU. This paper discusses the EI program and its salient features in preparing high school students for the engineering profession.

**2. Introduction of EI program:** EI program benefits high school students in three main areas: (a) introducing them to various engineering areas, while improving their STEM skills and self-efficacy,<sup>8</sup> (b) provide college credits<sup>5</sup> to eligible students, and (c) mitigating the disconnect between college and high school education.<sup>9</sup> EI is becoming popular and increasing number of participants are joining this program, not only from the USA but from the abroad. In 2011, 307 high school students attended EI program at various sites in the USA (Fig. 1). During 2011, following 16 sections taught in three states (Maryland, Pennsylvania, and California) and the District of Columbia:

- California Lutheran University located in Thousand Oaks, California
- California State University, Fullerton (CSU Fullerton) located in Fullerton, California
- Eastern Technical High School located in Baltimore, Maryland
- Johns Hopkins University, Elkridge campus (JHU Elkridge) located in Elkridge, Maryland
- Johns Hopkins University, Homewood Campus (JHU Homewood) located in Baltimore, Maryland (four sections – A, B, C, and D)
- Johns Hopkins University, Rockville campus (JHU Rockville) located in Rockville, Maryland (two sections – A and B)
- Tuscarora High School located in Frederick, Maryland (two sections – A and B).
- Pasadena City College located in Pasadena, California
- Sci-Tech High School (Sci-Tech) located in Harrisburg, Pennsylvania.
- University of Baltimore (UB), located in Baltimore, Maryland
- University of the District of Columbia (UDC) located in the District of Columbia.

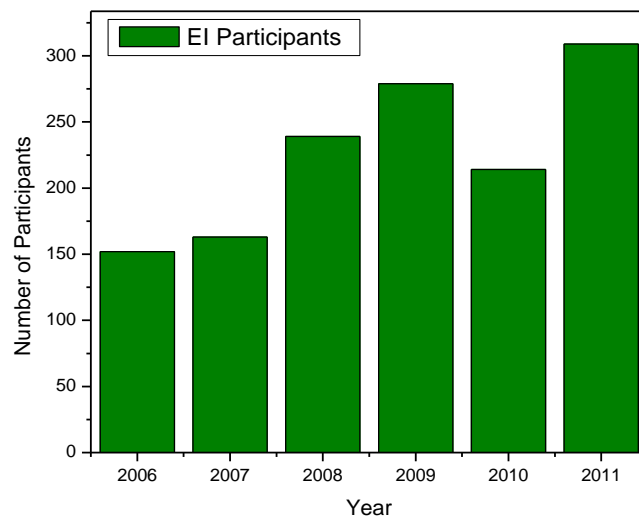


Fig. 1: Number of participants in EI program conducted from 2006-2011.

For every site, an instructor, generally with a PhD degree in an engineering discipline, and a regional high school teacher, generally with several years of teaching experience, are paired to conduct the EI program. Before the beginning of the actual EI program, instructors and teaching fellows undergo one week of rigorous training at Johns Hopkins University campus. During training instructors and teaching fellows are briefed in teaching fundamentals of multiple engineering disciplines. During

training instructors and teaching fellows conduct a variety of engineering experiments which the high school students will be required to do under the EI program for their problem based learning.<sup>10</sup>

EI course include the lecture and experiments pertaining to a number of important engineering disciplines.<sup>7</sup> In order to connect the class room instructions and the experimental learning to the real life applications, students are asked to apply material they have learned to make functional engineering systems. The engineering systems that student produce are designed to emphasize the core concepts of specific engineering streams.

To teach the components of mechanical, materials and civil engineering EI students make bridges. The bridge is expected to be made up of various trusses. Students are taught civil and mechanical engineering fundamentals to design trusses. Trusses are made up of various types of spaghetti; a cheap material which shows students that this edible stuff can be a resource for learning engineering. Spaghetti are the structural material for the truss, hence they are extensively studied under the materials experimental lab. In the materials lab, students measure bending, tension, and buckling properties of the various widths of spaghetti. After understanding the various types of material properties, students design individual bridge segments and justify their dimensions. The materials lab is one of the major components of the EI program, and serves multiple purposes. For instance, students learn how to analyze a large set of data using Excel, do error analysis and, more importantly, develop a representative mathematical model from the experimental data. Developing the representative mathematical model from the raw experimental data teaches students how to approach a new and vaguely defined real-life problem. Such skills are the core strength of an engineer or scientist which is generally never taught by a formal course; a student learns them as the need arises and in varying degrees. It is a major drawback that such skills are not discussed in general context and that their connection to science and engineering problems pertaining to real-life situations remain incompletely explored. EI endows high school students with the ability to deal with new technological problems via simple yet well-designed hands-on experiments.

The EI program acknowledges the fact that most of the high school participants did not take preparatory courses to assimilate engineering concepts. To bridge the knowledge gap and to provide an inquiry-based teaching of engineering fundamentals, generally the EI instructor presents interactive lectures on the major topics. For instance, before the materials lab, a classroom discussion is presented about the materials properties, usage, and testing. In order to use a material as a structural material students are taught statics. Students are asked to apply their understanding about statics in virtual experiments. In a virtual bridge designer experiment, students design their bridge and analyze the nature of compressive or tensile loads on the individual components of a bridge. After selecting a bridge design, based on their understanding of statics, students construct individual trusses/ bridge components utilizing their knowledge about spaghetti's tensile, buckling and bending strength learned in the materials class and lab.

To further teach the civil engineering basics or at least a small component of it, students perform a remote measurement lab. This lab utilizes a meter stick and string as the surveying tools to measure the aerial distance between the apexes of two multistory buildings. This outdoor lab teaches the ways to estimate engineering quantities using limited resources. Students apply trigonometry to accomplish the assignment and determine the systematic and random type common errors in their measurements. This EI assignment also let students experience the utility of learning math and their applicability in engineering and science.

To teach the electrical engineering concepts students are engaged in developing a microcontroller based mechanical system, which is a light sensing robotic car. Students are taught about the procedure to develop microcontrollers performing the intended tasks. To guide the students through the complex concepts, students are taught about the logic circuit and how to develop it by using Boolean logic and logic gates (mainly NAND gates). This lab also enables the students to understand the basics of robotics

and associated challenges. Developing a logic circuit from scratch and then seeing it functioning successfully is one of the most positive experiences that students had from the EI program.

To teach the chemical engineering basics, students first attend class discussion on important chemical engineering processes like chemical separations, chemical reactions, diffusion, chemical reactor design, and concepts of mass and energy conservation. Then students take part in a chemical processes lab to experience important chemical engineering steps. Chemical separation is the main theme of the chemical lab. Students do ethanol distillation from a mixture of water and ethanol. Students also do chromatography-based chemical separation. Students discover how to use a hydrometer and the Maccabe Thiele diagram for quantifying the distillation efficiency.

EI recognizes that successful and meaningful engineering careers involve understanding of various other subjects, not just mastering technical skills. Other subjects, which EI also includes in its curriculum, are professional ethics, finance, communication, and the ability to estimate.

To teach the vital role of ethics in engineering and science, an interactive session is designed. Different EI instructors conduct their ethical education session in various ways; generally by presenting numerous past ethical cases which adversely impacted economy, safety, or social wellbeing. Ethical education is imparted through discussion on the variety of case studies or hypothetical situations. Students explain their stand with regards to individual case studies. Through discussion with peers and instructors, they realize that in many cases the difference between right and wrong is not obvious. Interestingly, in the beginning EI students appeared to consider ethical discussion unnecessary or not important as they seemed to be content with their own ways of justifying right and wrong.

This program also includes discussion and assignments on the role of money and finance in engineering. Students perform calculations to understand how the value of money changes with time. They are asked how a long term project may be impacted by the changing value of money and the availability of finances. The EI lesson focuses on inculcating the importance of time and money in engineering. EI students are exposed to several types of interest rates, inflation, and methods of justifying long term finance via various strategies.

Engineering is heavily based on communications. In engineering, it is crucial that one engineer effectively communicate the guidelines and instructions for the other engineers to enable the accurate, economical, safe and efficient completion of a project. For instance, design engineers must effectively communicate the design of an engineering system to the production engineers. To make high school students realize the importance of communication, a number of assignment and activities are incorporated into the EI program. EI students partake in an exercise in which they design a mousetrap within the suggested constraint. Then this documented design is forwarded to a second group of randomly chosen students to build the mousetrap just “based on written instructions”. Finally, the second group of students test their mousetrap design and give their feedback about the issues they encountered to the students who wrote the instructions. This is a simple yet highly efficient way to impart the importance of clear articulation and effective communication. In the second communication assignment, students are asked to propose a solution to a pressing technological issue and then market their ideas to other students via a group presentation.

Estimation plays a crucial role in engineering projects. EI students are taught that engineers and scientist generally do not have access to the accurate value of all the variables, and even that they may not be aware of all the variables. The ability to estimate engineering and scientific quantities with minimal error becomes crucial in making important decisions. To hone the skills of estimation, EI students are administered a variety of Fermi problems. In fact instructors use them as buffer activities to break the monotony of long lectures and other EI activities. Most of the time, the EI final exam for earning college credit also includes an estimation problem.

To encourage students to pursue an engineering career, the EI program conducts an engineering connection day. On this special day engineers from renowned companies like Northrop Grumman, Ford, local construction companies, active research scientists and higher education specialists are invited to

share their insights and experience about engineering with EI students. Engineering professionals discuss their career journey, views about engineering work they are involved in, and their message for the budding engineers like the EI students. EI students have an opportunity to network and to get exposed to a number of engineering internship opportunities. For some sites, advanced degrees are also talked about. For instance this year the dean of the School of Engineering at UDC talked about potential advantages of higher education and numerous funding opportunities in graduate schools.

Along with the major EI activities, students are taught about graphing, report preparation, error analysis, dimensional reasoning etc.

In the final week of the EI, students work on a weeklong take home exam. Based on their performance in the final exam and grades in the EI assignments, which they did throughout the program JHU assigns their final grade. Also, in the final week of EI students work in teams to produce Spaghetti Bridge using their engineering skills. On the final day of EI, a bridge breaking competition is organized. Students test the strength of their bridges in the presence of peers, parents, EI staff and invited guests.

**3. Program evaluation:** The degree of success of EI program is measured by multi-faceted surveys. In the beginning of the EI program students are asked to fill out a pre-survey to record their skill levels, attitude for engineering, and future outlook. A similar survey is administered at the end of EI program to statistically quantify the impact of EI. In addition, EI alumni were surveyed to gauge the long term impact of EI on participating students. Survey of EI alumni was also important to map the EI effect from a new stand point. Alumni which are currently pursuing college degrees have a more matured and realistic outlook to reevaluate the EI effectiveness. For conducting these surveys and to evaluate the overall effectiveness of EI program an independent program evaluator was appointed. The external program evaluator also interviewed EI students and teaching staff about the various aspects of EI program. The findings and data discussed here is taken from the report prepared by the external program evaluator.<sup>11</sup>

**4. Findings:** EI program was attended by students of different demographics. Data suggest that female participation was 49% in the 2006 EI program. However, in other years it was significantly lower. In 2011 EI program only 26% of the participants were female (Table 1). Interestingly, the percentage of white students in the last three years have been in the 38-49 range; in the 2011 EI program it was 47% (Table 1). Percentage of Asian participants ranged from 13-29. Another interesting trend was observed with underrepresented minority participants. In 2006 it was 73%; however, this percentage dramatically dropped to 34%. Reduction in the female and underrepresented minority participants also appear to be correlated with the drop in the full or partial scholarships. Percentage of partially and fully supported EI participants decreased from 83% to 55%. It will be interesting and important to study if underrepresented minority and female participation can be boosted by the financial support.

Characteristics	2011	2010	2009	2008	2007	2006
% Female	26	31	31	37	32	49
% White	47	49	38	28	27	10
% Asian	21	29	25	22	13	14
% Underrepresented Minority	34	30	38	50	60	73
% Full or partial scholarship	55	47	54	66	72	83

EI program contents are considerably challenging. High school students are

generally selected by ensuring that they have earned reasonable proficiency in math, science, and English. Majority of the EI participants took biology, chemistry, algebra, algebra II and geometry (Table

3). The percentage of students who attended trigonometry, pre-calculus, and calculus were 69, 68, and 26, respectively. As discussed elsewhere in this paper, students who attended trigonometry and pre-calculus were found to assimilate EI material more effectively and were more likely to earn college credits. This trend is consistent with the observation about students in STEM disciplines at UDC. Students who completed pre-calculus were highly likely to complete the college degree in time.

Table 2: Percentage of 2011 EI participants taking prior science and math classes

Courses	Percentage
Biology	86
Chemistry	82
Physics	53
Algebra	87
Algebra II	90
Geometry	91
Trigonometry	69
Pre-calculus	68
Calculus	26

EI program allowed 9 to 12 grade high school students to attend the EI program. However, 10<sup>th</sup> and 11<sup>th</sup> grade high school students formed the major part of EI classes. In 2011 EI program 10<sup>th</sup> and 11<sup>th</sup> grade students were 34% and 51% respectively. In 2011, 9<sup>th</sup> and 12<sup>th</sup> grade students were 2% and 5%, respectively.

Effectiveness of EI was measured by surveying the EI participants' response to questions about specific engineering skills before and after the completion of program. Tabulated results showed that EI program significantly enhanced a number of engineering skills (Table 3). EI participants showed the highest gain in using Boolean logic (38% increase). EI participants learned basics of Boolean logic and then developed understanding about various types of logic Gates (AND, OR, NOT, NAND, XOR etc.). Students performed experiments on virtual circuit builder computer program to develop circuit diagrams to control the direction of motion of a robot car. Next highest increase was the communication of engineering design (37% increase). During one engineering communication exercise EI students wrote instruction for another student to construct a mouse trap. Under another communication exercise students worked in group to present solution for present day engineering issues—under this exercise they first communicated with the team members and subsequently as a team they communicated with the whole class. A significant improvement was noticed in participants understanding about dimensional analysis. After attending EI program students were able to understand the essence of dimensional quantities; their ability to give examples of dimensionless variables improved by 36%. A major gain was noted in using Microsoft Excel<sup>®</sup> software for engineering calculation and analysis (36% increase). During in person interviews a number of EI participants expressed their amazement about the capabilities of Microsoft Excel<sup>®</sup> software. During the analysis of materials lab data students utilized Microsoft Excel<sup>®</sup> software to develop model for representing bending and bucking load as a function of length and diameter of the mechanical testing samples. Students also used this software to do error analysis and engineering calculations. Table 3 enlists the percentage improvement in various engineering related skills due to the EI program.

Table 3: Percentage of students who could perform skills before and after 2011 EI program.

Skill	% pre	% post	Change from
-------	-------	--------	-------------



			pre to past
Use of Boolean logic	20	58	38
Write assembly instructions that someone else can follow	39	76	37
Give examples of non-dimensional variables	27	63	36
Use Microsoft Excel <sup>®</sup> to solve problems	43	76	33
Design and build a structure without a detailed plan	52	76	24
Describe uncertainty in a set of data using standard deviation	36	57	21
Apply data in scientific or engineering reasoning	55	77	22
Evaluate problems you've never seen before and whose answers can't be found in Google	47	67	20
Work with limits that are "proportional" to one another and not equal to one another	45	62	17
Use logarithms to analyze data	45	61	16
Describe equations using dimensions and units	61	76	15
Calculate a mean, standard deviation, and variance from a set of data	62	76	14
Deal with measurements that contain errors	54	68	14
Describe the properties of a force	50	64	14
Use a table of values to estimate a solution from raw data	60	74	14
Work with vector quantities	48	62	14
Develop your own problems or experiments to explore a concept or principle	50	62	12
Simplify a complex problem into a few key issues	58	70	12
Write a complex lab report that includes graphs and diagrams	59	71	12
Describe the physical properties of materials	69	79	10
Know when a problem isn't posed in a way that you can answer it	59	68	9
Estimate answers rather than calculating them	70	78	8
Make oral presentations to an audience	64	72	8
Sketch or draw two-dimensional or three dimensional objects	67	75	8

Use math to analyze data	74	80	6
Work with laboratory instruments or tools	78	84	6
Apply trigonometry to word problems	71	74	3
Identify when you don't know something in a problem	77	80	3
Visualize three-dimensional objects	73	76	3
Understand and solve word problems	77	78	1
Be a contributing team member	85	83	-2

EI program also provides college credits to eligible participants. EI program is ABET accredited and credits earned from this course can be utilized throughout the USA universities and colleges. To earn the college credit students are required to earn an A or a B in the course based on the final exam and in course assignments. In 2011 EI, 62% students earned the college credit. Percentage of student earning the college credit in the 2010, 2009, 2008 were 59%, 65% and 58%, respectively. Students' performance in EI program strongly correlated with their prior math preparation, which is in agreement with prior studies.<sup>12-14</sup> Data suggested that students with trigonometry and pre-calculus earned better exam grades and were more successful in earning college credits.

Finally students were asked to rate the EI program. More than 90% student rated EI program good, very good and excellent. More than 40% students rated EI program to be very good. This data signifies that EI program was a positive experience for most of the participants. According to interviews of numerous participants, EI program enabled them to appreciate the engineering from different angles, which they never imagined. It was also noticed that student tend to utilize their positive experiences in their high school classes. For instance, one 2010 EI participant wrote an essay during her high school class pertaining to the meaning of numbers, her new perception developed after attending the EI program. Beside this EI has produced long-term impacts on its alumni.

To study the long-term effect of EI program alumni were asked to participate in a survey. It was found that out of 102 surveyed alumni 80 alumni have made the decision about their college major. Cumulatively, 87% EI alumni are majoring in a STEM area (Table 10). Alumni who are majoring in engineering is 56%. This high percentage of EI alumni enrolment in STEM areas suggest that EI can play an important role in developing sustainable interest in STEM fields. This aspect is crucial because a large population of students who joined STEM area generally changed their disciplines after first year.

**5. Summary:** The core value of the EI program is that it teaches approaches to solving engineering problems and developing engineering aptitude. Students are given a number of individual and group assignments. They work in teams on major engineering experiments like: materials properties, structural design, robot construction, and bridge building. Prior to experiments, students take part in lecture and discussions on the relevant topics. The instructor and teaching fellow provide optimal pedagogy to foster independent critical thinking. During the EI program students are engaged in the discussion of professional ethics, engineering economics, and data analysis. At the end of the third week students are given a take home exam. Earning an A or B in this ABET accredited EI program make them eligible to get three JHU college level credits.

**Acknowledgment:** PT thanks Michael Karweit for designing engineering innovation program and nurturing it. PT also thanks Kathleen Dowell of EvalSolutions for the data analysis.

## References:

1. ASEE First Bell September 2, 2011 News Letter and <http://www.ajc.com/opinion/strong-u-s-needs-1155439.html>

2. US News Education Blog by Jason Koebler September 28 2011, <http://www.usnews.com/education/blogs/high-school-notes/2011/09/28/survey-stem-engagement-begins-early> &  
<http://www.microsoft.com/Presspass/press/2011/sep11/09-07MSSTEMSurveyPR.msp>
3. <http://www.cnn.com/2011/US/05/17/education.stem.graduation/index.html>
4. Mathers, N., M. Pakakis, et al. "Mars mission program for primary students: Building student and teacher skills in science, technology, engineering and mathematics." *Acta Astronautica* **69**(7-8): 722-729, and Carroll County Times, "Century senior recalls NASA summer program" Posted: Friday, September 30, 2011 5:15 am | Updated: 9:19 am, Fri Sep 30, 2011.
5. Wilbur, F. P. and D. W. Chapman (1977). "Transferability Of College Credit Earned During High-School." *College And University* **52**(3): 280-287.
6. Mercurio, J. A., L. Lambert, et al. (1983). "College Credit Earned In High-School - Comparing Student Performance In Project Advance And Advanced Placement." *College And University* **59**(1): 74-86.
7. <http://engineering-innovation.jhu.edu/>
8. Gore, P. A. (2006). "Academic self-efficacy as a predictor of college outcomes: Two incremental validity studies." *Journal of Career Assessment* **14**(1): 92-115.
9. Kirst, M. W. (2004). "The high school/college disconnect." *Educational Leadership* **62**(3): 51-55.
10. Urrestarazu, L. P., A. F. Salas, et al. "Multidisciplinary Education for New Landscape Engineering Concepts using Problem-Based Collaborative Learning. A Case Study in Spain." *International Journal Of Engineering Education* **27**(1): 138-145.
11. Kathleen Dowell, 2011, "Evaluation of the engineering innovation program" report prepared for Whiting School Engineering, Johns Hopkins University.

**The Power of University - Industry Collaboration: A Model Partnership**

Sofia M. Vidalis, Ph.D.  
Pennsylvania State University at Harrisburg  
Dr. Sofia M. Vidalis  
Assistant Professor of Civil Engineering  
Penn State at Harrisburg, The Capital College  
Civil Engineering and Engineering Technology  
777 West Harrisburg Pike, W-236  
Middletown, PA17057  
Office: (717) 948-6122  
Fax: (717) 948-6502  
svidalis@psu.edu

# The Power of University - Industry Collaboration: A Model Partnership

Sofia M. Vidalis, Ph.D.  
Pennsylvania State University at Harrisburg

## ABSTRACT

The goal of any university curriculum is to provide the information and skills so each student can be successful in a chosen career. This is especially critical for the Civil Engineering and the Structural Design and Construction Engineering Technology programs at Penn State Harrisburg. These programs are continuously planning, developing, and modifying their curriculum to keep abreast of the changes and advancements that are made in the engineering profession. The industrial relationships and partnerships that a program develops are critical elements to its success. Programs that foster and strengthen relationships with firms and professional associations will not only benefit the university but also those firms and associations.

This paper will discuss and model how Penn State Harrisburg's Civil Engineering and Structural Design & Construction Engineering Technology programs have been collaborating with the industry through its advisory board, financial support, student organizations, campus events, professional events, fieldtrips, and outreach programs. These various activities have been an excellent example of a win-win relationship between the university and its partners.

## INTRODUCTION

Partnership between an Educational Institution and Industry is not a new concept in fostering learning among students. There are many universities that work closely with business and industry partners to develop programs to fit their needs. Universities and industries traditionally maintained collaborations by including student internships, faculty exchanges, and industry design projects to complete a degree program. The purpose of these partnerships is to meet the needs of industries, governments, national laboratories, and the training needs of the university students.

The goal of any university engineering curriculum is to provide the information and skills so each student can be successful in a chosen career. This is especially critical for a civil engineering and engineering technology program. The program is continuously planning, developing, and modifying its curriculum to keep abreast of the changes and advancements being made in the design and construction engineering profession. The industrial relationships and partnerships that a program develops are critical elements to its success. Programs that foster and strengthen relationships with engineering firms and professional associations will not only benefit the program but also the engineering firms and associations.

The purpose of this paper is to discuss the connections between Penn State Harrisburg's Civil Engineering (CE) and Structural Design & Construction Engineering Technology (SDCET) program and the engineering industry. This paper will also discuss the various activities and programs for partnership that are conducted from the advisory board, student organizations,

national construction associations, financial support, and outreach. These various activities and programs have revealed excellent examples of a win-win relationship, which benefits both the university program and its partners.

#### ADVISORY BOARD

The program at Penn State Harrisburg has two advisory boards: SDCET and CE. Both advisory boards are unique in that its membership is a representative in various aspects of the design and construction engineering industry. The SDCET by laws requires the 21 membership to consist of SDCET graduates, small and large construction firms in addition to engineering companies which may have national and/or regional recognition in various aspects of the construction industry. The board also includes a representative from Pennsylvania Department of Transportation (Penn DOT), Associate General Contractors of America (AGC), Associated Builders and Contractors (ABC), a lawyer in construction law, an architect, and even a high school counselor. The CE program is a fairly new program at Penn State Harrisburg and therefore consists of fewer members. It currently has six active members on the board. The CE board includes a technical manager in transportation and water resources, a project manager, a bridge and tunnel maintenance coordinator, a President and two Vice Presidents of different civil engineering firms. Similar to the SDCET advisory board, the CE advisory board has similar by laws, consists of CE graduates, and small and large civil engineering firms. Both of the advisory boards present private, public, and government sections.

The membership composition provides valuable resources to legal and state licensure, exposure and interaction to secondary schools, interfacing with various audiences and employers of the design and construction engineering industry, and an advocate to each program. Both advisory boards act in advisory capacity to the CE and SDCET programs, the School of Science, Engineering and Technology, and the college. One of their goals is to identify the needs and trends regarding employment for the graduates. The board offers recommendations for improvement to the curriculum offerings and serves as an avenue of communication between each program and the design and construction engineering industry. The board assists in preparation of surveys and reports as required for their accreditation as well as other information for each program. Each advisory board promotes financial support to each program and student organization. The SDCET Advisory Board supports the Penn State Professional Engineers & Contractors (PSPEC) and the CE Advisory Board supports the Civil Engineering student club. They both support each student club in field trips to construction sites, networking events, hiring, and career and professional advice. In addition, have the opportunity to also be a guest speaker in engineering and engineering technology courses.

Both Advisory boards have been identified by the college to be an excellent example for industry and university collaboration<sup>1</sup>. Their activities show how different an industry and a civil engineering and engineering technology program both benefit. The advisory board activities include: design and construction engineering awareness luncheon for high school counselors, review of course syllabi, informal gatherings, student forums, networking events, and resource to the program and faculty.

Both advisory boards collaborate in many events. They host a luncheon that is held at Penn. State Harrisburg to inform high school counselors about the design and construction engineering industry: its economics, workforce, and job opportunities. During this luncheon, both advisory boards present and provides information on both CE and SDCET programs and why they feel it is excellent for high school students interested in the design and construction engineering profession. The CE and SDCET Career Fair is held right after the luncheon to which the counselors are also invited to attend to learn more about the industry from the various firms in attendance. The firms that attend the career fair provide displays and information about their companies. Most importantly, students have the opportunity to talk with the recruiters from many design and construction engineering firms and also have informal interviews about full-time, part-time, and internship/co-op positions. This event is always successful and numerous contacts are always made, which benefits both the firms and the students. It is also an excellent occasion to inform a key person to students on their career path about the design and construction engineering industry. The counselors have provided an opportunity for both programs to participate in numerous high school events, which are limited to other professions. This annual event has provided a great opportunity for counselors, firms, faculty, and students to network together.

The advisory boards annually review several course syllabi to ensure the material is current to the industry as well as provide advice to the instructors on course structure. A group of board members with the expertise in a particular subject in design and construction engineering reviews the material with the instructors of the courses. The advisory boards may also include key employees within their organization to assist in the review process. The constant interaction between academia and the industry is an essential requirement to train and develop students to have the knowledge of what is expected in the real world. The advisory boards' suggestions are valuable and therefore are incorporated in both civil engineering and engineering technology courses. The instructors also continue their relationships with the advisory boards' in consulting, research, or other activities to provide a win-win partnership.

## FINANCIAL SUPPORT

The first college endowment was created for the SDCET program to provide scholarships to students in the major. Additional endowments have been created for both CE and SDCET programs in order to support faculty, research, outreach programs, student development, and more student scholarships. Various construction and engineering firms as well as alumni have generated funds to support these endowments for both programs. The local construction and engineering associations have also created their own undergraduate scholarships with one criterion being that the student must be majoring in either the civil engineering or engineering technology program. This demonstrates their commitment and their partnership to Penn. State Harrisburg.

## STUDENT ORGANIZATION PARTNERSHIPS

### Penn State Professional Engineers and Contractors

Penn State Professional Engineers and Contractors (PSPEC) is an umbrella organization of three national associations: Associated General Contractors, Associated Builders and Contractors and the National Society of Professional Engineers. The club's activities and commitment to the program is a key component to the student's education, for professional growth, and also to keep them current with the construction industry. Members of PSPEC also produce a resume book annually, which is sent to more than 150 firms. This book contains resumes of students in the SDCET program and it is separated into three sections. The first section provides information and a brief overview about the SDCET program, the typical course of study the students take, and the course description. The second section contains resumes from graduating seniors, for full-time positions. The last section contains resumes of students who are seeking summer employment or part-time positions. PSPEC gets involved with various activities with the industry. The various activities include: inviting guest speakers, arrange construction project visits, and local sponsoring chapters activities<sup>2</sup>.

Inviting guest speakers to make a presentation, as stated earlier, help the students learn different aspects of the construction industry. The speakers bring valuable educational opportunities to the students about topics by owners, managers, clients and even alumni graduates from Penn State University programs that are involved in that profession. PSPEC also arranges construction project visits with firms. In some cases, the projects are restricted to the outside arena but student organization obtains access to these sites. The firm realizes the importance of assisting the students in their education. PSPEC conducts an annual two-day field trip to Pittsburgh, Pennsylvania towards the end of October, which includes visiting several projects and attending a dinner with the highway and building contractors<sup>3</sup>. In addition, another one-day field trip to Baltimore, Maryland is made in the spring. These trips include high-rise buildings, bridges, institutional, or transportation projects, concrete batch plants, engineer/contractor offices, and testing laboratories. The members are provided first-hand knowledge of how the process is done which helps them relate to things discussed in the classroom. Most project sites allow the students to actually be there next to the workers performing the work. Being in a tunnel that is being dug, going down into a caisson in the middle of a river, seeing concrete poured at 1,200 feet above the ground, or driving a highway that you had walked on during a field trip are experiences these students will always remember.

In addition, PSPEC also has a number of members that attend "CONEXPO" which is held every four years in Las Vegas, Nevada. Students that attend the world construction exposition get to see new construction equipment and technology, exhibits, education sessions, certification programs, and conferences. They also have the opportunity to network with industry professionals at the CONEXPO<sup>4</sup>. The event is also held in conjunction with the national AGC conference at the same site so the students participate in both events.

PSPEC sponsoring chapters have the members involved in their activities. Several students are invited to attend the monthly meeting so they can interact with the members. The chapter allows students to attend seminars that are of interest. Most chapters have an education committee that



serves as the liaison to the student chapter. This committee conducts fundraising activities that support the student chapter and/or the program. Depending on the local chapter, these funds are given to the program, available to the student chapter for their activities, or used to help defer the cost of attending the national conferences.

The "Network Night" event is an informal gathering for Penn State alumni, students, and the advisory board of SDCET<sup>1</sup>. The relaxed atmosphere with light refreshments makes the current students comfortable as they meet graduates; learn about the jobs, and network. During this event, students are able to gain valuable information to contribute in professional growth. The advisory board was recognized and won a university award for this event. A Student Forum is done annually by the advisory board. This allows SDCET students to have the opportunity to network with the advisory board members and ask questions about the program.

### Civil Engineering Student Club

The Civil Engineering Student Club started the fall of 2010. It would not have been feasible without the support of the local ASCE Harrisburg Parent Chapter and industry. It is currently under review by the American Society of Civil Engineers (ASCE) to become an ASCE student chapter at Penn State Harrisburg. Although the student club is fairly new, it has been very active with networking events and conferences with the help of the local parent chapter. In the past year, the student club has been actively involved in numerous events. The two major events that have increased the industry and student collaboration were the ASCE dinner meetings and the mock interview event.

The local ASCE dinner meeting events are scheduled once a month during the academic semesters, six times a year. These dinner events consist of bringing the industry and students together. The event always begins with a social hour for the students and industry to network, then a formal dinner, and a presentation on a civil engineering topic. It is a great event for students to network with the local civil engineering industry and also get exposed to information in the field of civil engineering from invited guest speakers. It also benefits the industry because each ASCE dinner meeting counts for one professional development hour.

The most successful event that the CE student club held was the mock interview and panel discussion. The Civil Engineering program at Penn State Harrisburg held a Mock Interview and Panel Discussion event to help students better prepare for an interview as realistic as possible. This was accomplished by inviting professionals from the industry from the construction management and engineering design fields to interview the students. The program used a structured approach in the mock-interviews with the interviewers rating each student from a scale they had created based on their poise/self-confidence, communication skills, experience, and closing; see Table 1. Similar to speed dating techniques, each student had a 20-minute interview with each professional and then was critiqued on their performance. During the mock interview process, each professional was given his/her own table to conduct the interview. The interviews were set up similar to that of a speed dating process. Speed dating is a process whose purpose is to encourage people to meet a large number of new people. This process allowed students and professionals to conduct more interviews. Since the students knew the firms that each professional was representing in advance and from the networking during the social hour,

the students could identify specific professionals from their fields for their 20 minute interviews. A timer was used during the event so that each person knew when to start and end on time. Then each student would then go to the next interview table and go through another 20-minute interview with the next professional. Since the event was only two hours long, each student had a chance to go through the interview process with three different professionals. At the end of each interview, the professionals were given about five minutes to go over each student's strengths and weaknesses. The event closed with the professionals making some comments and then opened up for any questions. Even though this event was to prepare students for a formal interview, several professionals made offers for internships and full-time job opportunities with their companies. After the event took place, an e-mail was sent out to the professionals thanking them for their participation with a questionnaire for their feedback. In addition, thank you cards were also sent out to all the participating firms for helping to make this a successful event. All of the industry professionals mentioned that their experience with the students was very positive. The students mentioned that the Mock Interview Event was a great way to become more comfortable in an interview setting. The students also received a lot of good feedback and criticism on their resume and overall interview. The industry professionals also mentioned that the students looked very eager to be there, which made the event even more successful. Overall, the experience between the students and the industry professionals was a very positive and rewarding experience.

## NATIONAL ASSOCIATIONS

Associations like American Society of Civil Engineers (ASCE), Associated General Contractors of America (AGC), Associated Builders and Contractors (ABC), United States Green Building Council (USGBC), and Pennsylvania Society for Professional Engineers (PSPEC) understands the importance of higher education and their relationships to programs like SDCET. They provide a variety of educational and research programs that support construction education and the student who are entering their profession. These associations offer numerous types of scholarships, awards, recognitions, up-to-date information, training opportunities, and conferences. The following shows some of what the associations offer:

- The associations offer undergraduate scholarships to students in accredited construction and civil engineering programs. The successful recipients receive the scholarship annually while completing their degree. This makes a difference in their education. The foundations also provide a limited number of graduate scholarships. Both CE and SDCET programs have been successful with numerous students receiving the undergraduate scholarships in the past.
- Several constructor associations recognize a university instructor who prepares these students for the construction industry. This award that is given at their national meeting, allows the association to acknowledge the accomplishments of faculty who have contributed to their programs and the construction industry. A SDCET faculty member has received this prestige award in the past.
- The associations recognize the value of faculty participating on their committees. The faculty is a key player to the constructors in developing educational initiatives and supporting

students. This is an excellent chance for the construction industry to interact with faculty towards educating the future constructors. Faculty members in both the CE and SDCET programs have been appointed to numerous of these national association committees as well.

- The AGC's Education and Research Foundation board comprises of past national AGC presidents and two educators. They oversee the selection of the undergraduate and graduate scholarships recipients as well as awarding university research projects. The foundation identifies the research and solicits universities to seek funding. The SDCET chairman recently completed his second three-year term on the foundation board. Again, this relationship has provided a win-win partnership.
- One association allows student access to their web site, which provides up-to-date information on legislative issues, training opportunities, safety standards, and copies of standard documents that are used in most of the construction projects in the United States. It is a good resource and research tool that students can use.
- Most of these associations allow the students to attend their national conference for a nominal fee. The students have the same opportunities as the association members in attending presentations, visit exhibit areas, and network events. This has proven to provide internships, jobs, discounts to software and products and partnerships with the program.

#### OUTREACH PROGRAMS

Another key partnership with the design and construction engineering profession is the CE and SDCET outreach. The activities have fostered into a rewarding experience for both the firms and the SDCET program. Some of these activities include: research, part time job opportunities, continuation of education, workshops, and many other opportunities of keeping current with the industry.

- The construction industry has provided frequent opportunities for the program's faculty. Faculty has consulted with firms to specific initiatives or research projects. Some of these partnerships have developed into a funded research project for the faculty member. This partnership has supported the knowledge to firms and the program.
- The firms have hired faculty during the summer. This allows the faculty member to keep current in the industry, which is essential in the constantly moving industry. The faculty member takes this experience back to the classroom so the curriculum is integrating this material. The firm's also benefit from the faculty members expertise and skills, which becomes a valuable resource. The firm continues the partnership with the faculty member during the academic year. This partnership provides firms an opportunity to become more involved with the program, its students, and their future employees.
- The program offers outreach programs to the construction community, which has benefited in this partnership. A firm has contracted on site training from the college on specific topic, which the faculty is the instructor. The program offers workshops, presentations, and continuing education courses that give opportunity for various firms to

obtain the information. These professions may be required to obtain training or continue their learning in approved Continuing Education Unit (CEU) programs. The university's resources have provided an excellent environment to deliver the program at one location, state wide, and by the Internet superhighway across the world. The two programs continues to partner with the construction industry and contribute its future.

## CONCLUSIONS

The various activities and organizations from the advisory board, financial support, student organization partnerships, national associations, and outreach programs demonstrate the partnerships universities can have with the construction industry. This partnership is a win-win relationship because at the end, they both help each other. They also both realize the need to work together for the betterment of the students and the construction industry's future. These students will be the future leaders, and both parties have a responsibility to educate the students about their profession. The various activities and rewards are only limited to the amount of commitment the construction program places on these relationships. The programs that foster and strengthen relationships with design and construction engineering firms and professional associations will not only benefit the program but also those firms and associations. The more the students get exposed to the various activities and organizations that the school provides, the better prepared the student will be to face the challenges of the real world.

## REFERENCES

1. "Currents," Penn State Alumni Magazine, Fall 2006.
2. Science and Engineering Technology (SET) News (Fall 2003), [www.cl.psu.edu/set/docs/set\\_news\\_letter\\_fall03.pdf](http://www.cl.psu.edu/set/docs/set_news_letter_fall03.pdf), Accessed 1/12/08.
3. "Executive Summary," Construction Association of Western PA. Newsletter, November 2007
4. CONEXPO(2008). <http://www.conexpoconagg.com/>. Accessed 1/10/08.

Table 1: Interview Rating Sheet

Name: _____ Interviewer: _____		Below Basic	Basic	Proficient	Advanced	Comments
Preparation	Turn off cell phone/pager. Resume					
Poise/Self-Confidence	Introduces self with firm handshake & friendly greeting. Avoids nervous actions and mannerisms during interview. Reacts appropriately. Sits correctly with good posture. Maintains eye contact. Refers to interviewer by name.					
Communication Skills	Uses correct grammar and avoids slang. Speaks slowly and clearly. Avoids mumbling. Answers questions thoroughly but keeps answers pertinent. Phrases responses in short, simple sentences. Ask appropriate questions.					
Experience & Skills	Does not criticize former employer. Does not discuss personal problems, finances, religion, or politics. Listens closely to any questions and comments. Makes positive statements. Clearly describes value from experiences/skills/related coursework.					
Closing	Thanks employer for interview with firm handshake. Ask preferred communication type for future correspondence.					

**Nanotechnology in Undergraduate Education:  
Environmental Health Implications of Nanotechnology**

Mira S. Olson  
Drexel University, Philadelphia, PA

Patrick L. Gurian  
Drexel University, Philadelphia, PA

Alisa Morss Clyne  
Drexel University, Philadelphia, PA

Wan Shih  
Drexel University, Philadelphia, PA

Wei-Heng Shih  
Drexel University, Philadelphia, PA

Peter Lelkes  
Drexel University, Philadelphia, PA

## Nanotechnology in Undergraduate Education: Environmental Health Implications of Nanotechnology

Mira S. Olson, Patrick L. Gurian, Alisa Morss Clyne, Wan Shih, Wei-Heng Shih and Peter Lelkes  
Drexel University, Philadelphia, PA

The NUE at Drexel University introduces an integrated program focused on the environmental and health impacts of nanotechnology into the undergraduate curriculum. The goal of this project is to train environmentally conscious engineers, dedicated to minimizing unintended consequences of nanomaterial development and use to humans and ecosystems. An undergraduate course, "Environmental and Health Impacts of Nanotechnology", combines weekly lectures with alternating lab sessions and topical seminars. Each week, lecture and activity, progresses through the life cycle of nanomaterials. Beginning with the fabrication of various types of nanomaterials, students compare applications, waste generation and disposal methods, environmental transport, exposure to humans and ecosystems, toxicity, and finally risk characterization. Following the course, select students participate in 6-month research appointments as a part of Drexel's cooperative education program, in which they can further explore the environmental and health risks associated with nanotechnology. This integrated approach to nanotechnology education combines foundational knowledge with application, critical thinking, and a human dimension to maximize significant learning.

**The Temple University Nanotechnology Undergraduate Education Initiative:  
A Sustainable Urban Environment Advanced  
by Engineers Empowered with Nanotechnology**

Svetlana Neretina  
Department of Mechanical Engineering,  
Temple University,  
Philadelphia, PA 19122



## **The Temple University Nanotechnology Undergraduate Education Initiative: A Sustainable Urban Environment Advanced by Engineers Empowered with Nanotechnology**

*Svetlana Neretina*

Department of Mechanical Engineering, Temple University, Philadelphia, PA 19122

In the fall of 2011 a group of researchers and educators at the College of Engineering at Temple University received a National Science Foundation award under the auspices of the Nanotechnology Undergraduate Education (NUE) program to carry out an initiative aimed at the broad-based introduction of nanotechnology into the undergraduate curriculum. The program which sees participation from the Mechanical, Civil and Environmental, and Electrical and Computer Departments has a unifying theme of advancing a sustainable urban environment through the use of nanotechnology. The overall goals of the initiative are twofold: (i) the broad inclusion of a nanotechnology component within the undergraduate engineering curriculum and (ii) to provide undergraduate engineering students with a hands-on experience directed towards the use of nanotechnologies in advancing a sustainable urban environment. The first objective is founded on the premise that nanotechnology will become a ubiquitous part of a modern society and should, therefore, become a ubiquitous part of the engineering curriculum. Already, nanotechnology modules have been introduced into the seven undergraduate courses: *The Bionic Human (ME 0844)*, *Material Science for Engineers (ENGR 3496)*, *Introduction to Bioengineering (ENGR 3719)*, *Renewable and Alternative Energy (ME 4040)*, *Mechanics of Composite Materials (ME 4311)*, *Photovoltaic System Design for Engineers (ME 4110)*, and *Water and Wastewater Systems Design (CE 4721)*. The 2011 fall semester will also see the introduction of the College of Engineering's first course offering dedicated solely to nanotechnology. The course, *Nanotechnology Solutions for a Sustainable Urban Environment (ENGR 4577)*, will be offered as an elective to junior and senior students from all engineering departments. The second objective is advanced through the introduction of five undergraduate laboratory modules and through ten week summer research internships in nanotechnology. In the 2011 summer semester seven undergraduates have worked in research laboratories undertaking projects which advance nanotechnology in such disparate topics as water purification, fuel cell technologies for the transportation sector, renewable energy, self-assembly and bioengineering. The presentation will describe the initiative in detail, highlight its successes and examine its effectiveness in advancing both knowledge and interest in nanotechnology.

**An Engineering Elective on Energy Sustainability:  
Renewable, Nuclear, and Fossil Fuels**

Shih-Liang (Sid) Wang  
Department of Mechanical Engineering  
North Carolina A&T State University  
Greensboro, North Carolina 27411

## An Engineering Elective on Energy Sustainability: Renewable, Nuclear, and Fossil Fuels

Shih-Liang (Sid) Wang  
Department of Mechanical Engineering  
North Carolina A&T State University  
Greensboro, North Carolina 27411

### **Abstract**

As the Fukushima nuclear disaster discredits nuclear energy and the price of oil continues to soar, renewable energy (wind and solar, especially) seems promising but can yet replace coal for base-load power. At this disorderly time, the author is preparing an elective on energy for next semester to provide students with a technological foundation and economic fundamentals of energy options. The course will review the history of energy resources and usage, and will outline the science, technology and economics of each option. A premise of the course is that a sustainable energy technology must be technically feasible, economically viable, and environmentally responsible. The course will examine various energy options, including solar, wind, biomass, oceanic, geothermal, hydropower, fuel cell, nuclear, oil, gas, and coal. Technological progress of each option will be reviewed, along with economic opportunities and challenges.

The objective of this course is to introduce fundamental principles of the various energy options as we face climate change and other environmental impact, and to develop an appreciation of the energy challenges that confront our present and future generations. Although several textbooks are useful as references to this course, additional resources are needed to make the course contents contemporary and relevant. This paper is to report the author's effort in preparing course materials for this upcoming course.

### **Overview**

Energy and environmental issues are constantly grabbing headlines: climate change and extreme weather, fossil fuel burning and greenhouse gas emissions, water pollution of hydraulic fracturing of shale gas, BP oil leak, Fukushima nuclear accident, Keystone pipeline for Canadian tar sand oil, and recent bankruptcy filings of two American solar companies: Silicon Valley's Solyndra and Evergreen Solar of Massachusetts. While these headlines are getting our attentions on safety, environmental impact, and commercial viability of renewable energy, the energy sector (oil and gas companies, utilities, and equipment manufactures) is actively recruiting our students. This course is intended to prepare our students with energy literacy and numeracy, and prepare those who want to seek jobs in the energy sector.

This course intends to provide a thorough introduction to the economic, social, environmental, and policy issues related to current systems of energy use. In addition, key physical and engineering features of these systems will be studied. The course will address the present status of conventional fossil fuels and nuclear power. These systems, along with hydropower and traditional biofuels, currently supply the majority of the world's commercial energy.

Concerns over non-renewable energy resources have spurred research and development in renewable energy. With tax credits and subsidies, wind and solar energy are being rapidly deployed. However, the intermittent nature of renewable energy prevents its large-scale adoption,

as the storage and transmission issues are not resolved yet. This course will provide our students with a background necessary for the transition to the future.

In the aftermath of Fukushima accident, nuclear safety becomes a big concern. Japan is reconsidering its nuclear policy, while Germany and Switzerland are phasing out nuclear energy. However, nuclear energy accounts for about 20 percent of electricity generation in the United States and 14 percent of the world's electricity, and nuclear will be in the energy mix for the foreseeable future. In this course, different types of light water reactors will be addressed and safety of nuclear power will be discussed.

## **Course Objectives**

The subject of energy and sustainability is multifaceted and interdisciplinary, involving engineering, applied sciences (physics, chemistry, biology, and geology), economics, and public policy. This course intends to give an introductory account of the present world energy situation with basic energy concepts and human energy needs. Energy supply from various resources is studied and analyzed as we face climate change and other environmental issues. It is intended that students will develop a better understanding of the energy challenges that confront our present and future generations.

## **Course Description**

The course introduces the basic concepts, principles, potentials and limitations of various energy sources, including the fossil fuels nuclear power, and renewable energy. The course will cover how that energy is supplied, the anticipated global growth in energy demand, the resource availability, and meeting that demand in a sustainable way. Basic characteristics energy storage systems and smart grids will also be addressed.

## **Course Outline**

### I. Overview

- Energy and Environment
  - Energy demand and population growth
  - Greenhouse gases and climate change
  - The Kyoto Protocol – the United Nations Framework Convention on Climate Change
- Energy Conversion
  - Thermodynamics: first and second laws, Rankine cycle and steam turbine, Brayton cycle and gas turbine
- Electricity
  - Generation, transmission, distribution, smart grid
  - Base-load, intermediate and peaking power plants

### II. Fossil fuels

- Coal
  - Types, sources, mining, and reserves
  - Coal-fired power plants, flue-gas, and other environmental impacts
- Oil
  - Geology, history, exploration and production
  - Oil transportation and refineries
  - Deep sea exploration and oil spill

- Tar sand and oil shale
- Natural Gas
  - Geology, history, exploration and production
  - Shale gas
  - Gas turbines and combined cycle

### III. Nuclear

- Nuclear Energy
  - Fission, light water reactors, and safety
  - Nuclear fuel and waste

### IV. Renewable

- Solar Energy
  - Sun path, insolation, radiation, and tracking
  - Photovoltaic systems
  - Solar thermal systems
- Wind Energy
  - Wind resources, turbines, aerodynamics, and electricity generation
  - Offshore wind farms
  - Efficiencies, economics
- Hydroelectricity
  - History, resources, and hydroturbines
  - Dams, reservoirs, and pumped storage
- Geothermal:
  - Physics and resources
  - Electricity generation
- Tidal and Wave Power:
  - Physics and resources
  - Energy conversion devices
- Energy Storage and Transmission
  - Batteries, super-capacitors, flywheels
  - Compressed Air Energy Storage (CAES)

## **Textbooks and References**

As the author intends to cover the comprehensive subjects with enough technical depths and up-to-date information like shale gas, tar sand, nuclear disaster, wind and solar energy, it becomes obvious that an ideal textbook is not there. Therefore the author decides to use several books [1, 2, 3, 4, 5, and 6] as references, and supplement these books with additional resources.

For example, Energy Explained, by U.S. Energy Information Administration [7] has good explanation on energy fundamentals with important statistics. Energy Topic Guides from New York Times and its Green blog [8] contain the following tabs: Biofuels, Tidal & Wave, Natural Gas, Geothermal, Hydro, Nuclear, Coal, Oil, Solar, and Wind. Likewise, the Guardian has an Energy page [9] containing the following tabs: biofuels, energy efficiency, fossil fuels, green technology, nuclear power, renewable energy, solar power, wind power. These two newspaper sites, along with other news media, provide up-to-date and good photos, graphs, and videos on energy and environment issues. In addition, NRC Information Digest [10] contains useful information on nuclear energy. Tennessee Valley Authority on its web site [11] has good graphics and videos on fossil-fuel generation, hydroelectric power, nuclear energy, and renewable energy.

Many universities offer courses in energy, and several professors put a lot of valuable course materials on the web. Professor T.F. Edgar of the University of Texas at Austin has a course website on ChE 359-384 Energy Technology and Policy [12]. Dr. David T. Marx of Illinois State University has a course website on Physics 207 Energy and Society [13]. Professor Frank Leslie of Florida Institute of Technology has a course website on ENS 4300 Renewable Energy and the Environment [14].

## References

- [1] Energy Systems and Sustainability: Power for a Sustainable Future, by Godfrey Boyle, Bob Everett and Janet Ramage, Oxford University Press, 2004.
- [2] Energy for Sustainability: Technology, Planning, Policy, by John Randolph and Gilbert Masters, Island Press, Washington, DC, 2008
- [3] Sustainable Energy: Choosing Among Options, by Jefferson Tester, Elisabeth M. Drake, Michael, Driscoll, and Michael Golay, MIT Press, 2005
- [4] Renewable Energy (2<sup>nd</sup> edition), by Boyle, Godfrey, Oxford University Press, 2004.
- [5] Introduction to Energy, by Grossman Cassedy, Cambridge University Press 1998
- [6] Energy Systems Engineering: Evaluation and Implementation, by Francis Vanek, Louis Albright, McGraw-Hill Professional, 2008.
- [7] Energy Explained, U.S. Energy Information Administration (EIA),  
<http://www.eia.gov/energyexplained/>
- [8] Green blog of New York Times, <http://green.blogs.nytimes.com/>
- [9] Energy of The Guardian, <http://www.guardian.co.uk/environment/energy>
- [10] NRC Information Digest, <http://www.nrc.gov/reading-rm/doc-collections/nuregs/staff/sr1350/>
- [11] Tennessee Valley Authority, <http://www.tva.com/power/index.htm>
- [12] ChE 359-384 Energy Technology and Policy - UT Austin,  
[http://www.che.utexas.edu/course/che359&384/lecture\\_notes.html](http://www.che.utexas.edu/course/che359&384/lecture_notes.html)
- [13] Physics 207 Energy and the Environment, Illinois State University,  
<http://www.phy.ilstu.edu/~marx/phy207/>
- [14] ENS 4300 Renewable Energy and the Environment, Florida Institute of Technology,  
<http://my.fit.edu/~fleslie/>

## **Adapting the Tracing Method to Java**

TOM M. WARMS  
Pennsylvania State University Abington College

KAVON FARVARDIN  
Pennsylvania State University

TOM M. WARMS

Tom M. Warms is a faculty member in the department of computer science and engineering at Penn State Abington. He received S.B. and M.S. degrees, both in mathematics, from MIT and NYU, respectively. He received his Ph.D. in formal linguistics and mathematical logic from the University of Pennsylvania in 1988. He has published papers in pattern recognition, psycholinguistics and computer science pedagogy. Dr. Warms may be reached at [t1w@psu.edu](mailto:t1w@psu.edu).

KAVON FARVARDIN

Kavon Farvardin is an undergraduate student majoring in computer science at the Pennsylvania State University. He may be reached at [kff5027@psu.edu](mailto:kff5027@psu.edu)

# Adapting the Tracing Method to Java

Tom M. Warms

Pennsylvania State University Abington College

Kavon Farvardin

Pennsylvania State University

**Abstract** - The tracing method and its software implementation RandomLinearizer are proving to be effective tools in the teaching of C++. This paper discusses the issues involved in adapting the method to the Java programming language, and presents several typical Java programs that are presented to beginning students, and the corresponding traces. It then speculates on the usefulness of tracing to students of Java.

## Introduction

The tracing method provides a set of notations in which to represent the execution of programs in a limited subset of a programming language. It is a method<sup>1</sup> by which an instructor can demonstrate some of the features and algorithms of a programming language, and students can demonstrate their understanding. It is a useful tool for beginning students because it helps them learn elementary techniques such as decision structures and looping; it is also useful to more advanced students because of its capability for helping students learn more advanced techniques such as pointers and linked lists. It supplements the kind of verbal and pictorial descriptions of the execution of elementary programs that one finds in textbooks.

The method has been shown<sup>2</sup> to clarify the execution of some programs and explain why certain techniques that may seem to work will not. A software program named RandomLinearizer<sup>3</sup> was created in support of the tracing method; an experiment showed<sup>4</sup> that students enjoyed using the method and software and found it useful. The method and software were written for C++; the current paper is a preliminary evaluation of the method's suitability for use with the Java language; it speculates on the utility of tracing to students who are learning Java as their first programming language, and to students for whom the first language was C++ and who learn Java in subsequent courses.

## Tracing

In the method, names of identifiers are placed on the left side of a vertical line and the identifiers' values on the right. The name of the function being executed appears above the vertical line. Boxes indicate output, underlines indicate input, and ↵ represents the RETURN character. Values returned by functions are enclosed in circles. Figure 1 shows a simple C++ program and its trace, assuming an input value of 23. When tracing a statement in a program, the student has available the result of tracing the previous statements in the program.

---



```

// This program doubles an input value.
#include <iostream>
using namespace std;

int main()
{
    int number, doubleNum;

    cout << "Enter an integer ->";
    cin >> number;

    doubleNum = 2 * number;

    cout << "The number = " << number << endl;
    cout << "Twice the number = " << doubleNum << endl;

    return 0;
}

```

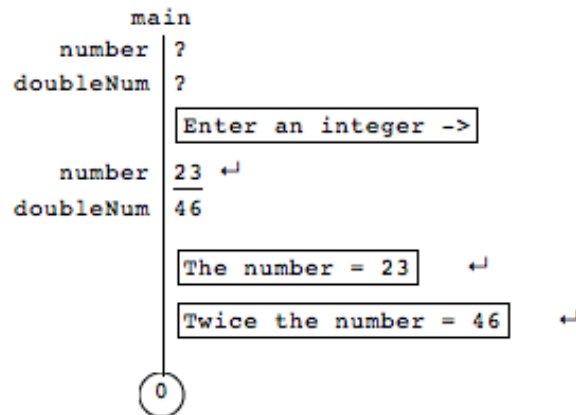


Figure 1

---

Elements of the trace of a program—the underlined material, material in boxes, and return characters—can be used to predict the contents of the console screen. The trace in Figure 1 suggests the following contents:

```

Enter an integer ->23
The number = 23
Twice the number = 46

```

A C++ program that uses a user-defined function to do the same calculation, and its trace, are shown in Figure 2. When control is transferred to the function `calculateAnswer`, the trace moves to the right, and the values of the formal parameters are indicated. Then the trace shows the execution of statements of the function block, the value returned by the function is encircled. The trace then moves back to the left.

---

```

// This program uses a user-defined function to calculate
// twice the input value
#include <iostream>
using namespace std;
int calculateAnswer(int num);

int main()
{
    int number;

    cout << "Enter an integer ->";
    cin >> number;

    int doubleNum = calculateAnswer(number);

    cout << "The number = " << number
         << endl;
    cout << "Twice the number = "
         << doubleNum << endl;

    return 0;
}

int calculateAnswer(int num)
{
    int answer = 2 * num;
    return answer;
}

```

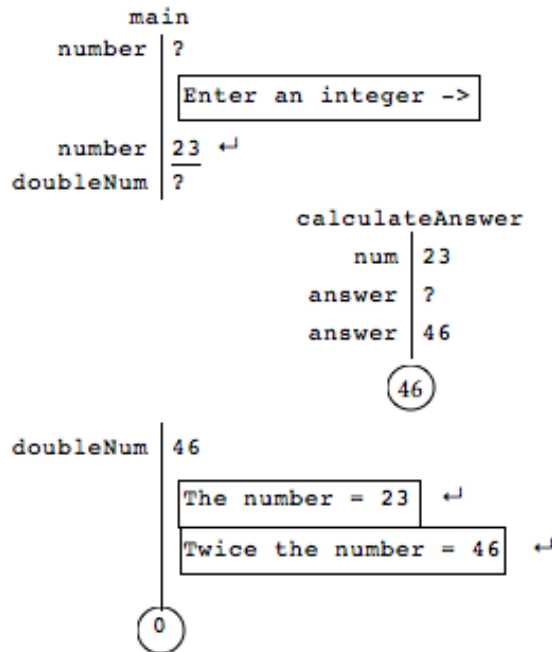


Figure 2

---

Java is similar in many ways to C++. An excellent exposition of similarities and differences is provided by Eckels<sup>5</sup>. Elementary C++ programs such as those of Figures 1 and 2 carry over without major change. In Java, however, a class must be created even to accomplish simple tasks. Figure 3 contains a Java program that is equivalent to the C++ program of Figure 2, along with its trace.

The header of the main program in Figure 3

```
public static void main(String [] args){
```

is traced by

```
main
args | null
```

The identifier args is a String array, initially null. Although console output is convenient to use in Java, as in the statement in Figure 3

```
System.out.println("The number = " + number);
```

console input is not. System.in on its own only allows for fetching bytes from the standard input; Scanner provides a wrapper for this object to make it usable by beginners. The statement

```
Scanner console = new Scanner(System.in);
```

contains a call to a constructor of the Scanner class, and thus creates an object of this class. Memory is allocated by new, and its machine address is returned as a reference and assigned to console. A complete trace sequence would indicate that System.in is the parameter and would provide details of the constructor's execution, but perhaps be confusing in its complexity. The solution arrived at is to abbreviate the sequence to

```
console | null
console | ADDR0
```

to indicate that console's initial value is null, and then it is assigned the object reference. The student can consider this to be an idiomatic trace sequence. The statement

```
String inString = console.next();
```

assigns to inString the next string that is entered at the console. It is then converted to int and the result is assigned to number:

```
number = Integer.parseInt(inString);
```

The sequence

```
inString | ""
                ADDR0.next
                ("23")
inString | "23" ↓
number   | 23
```

traces this segment. The quote marks indicate that the value of inString is indeed a String value, while the underline indicates that 23 is visible on the console.

```

class Main{
    public static void main(String [] args){
        int number;
        Scanner console = new Scanner(System.in);

        System.out.println("Enter an integer ->");
        String inString = console.next();
        number = Integer.parseInt(inString);

        int doubleNum = calculateAnswer(number);

        System.out.println("The number = " + number);
        System.out.println("Twice the number = " + doubleNum);
    }

    public int calculateAnswer(int num)
    {
        int answer = 2 * num;
        return answer;
    }
}

```

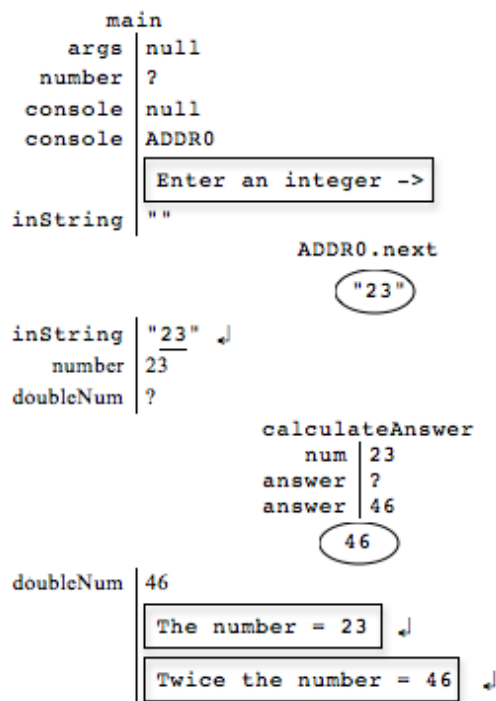


Figure 3

Java's graphic user interface provides methods of the `JOptionPane` class to prompt for input and report output--for example, `JOptionPane.showInputDialog` provides a value for `inString` in the same way as a call to a `Scanner` method, and `JOptionPane.showMessageDialog` prints output.

### Pass by value and pass by reference

In C++, a user-defined function that returns more than one value does so by reference. That is, the function's parameters, called reference parameters, are placeholders for the actual parameters in

the calling program. The program in Figure 4a uses reference parameters in a function that calculates the sum and product of two input values. In the trace of Figure 4b, the arrows between actual parameter sum and formal parameter total, and between actual parameter product and formal parameter indicate the connection.

```
---  
  
// Program to prompt user for two integers and calculate and print  
// their sum and product. The calculations are performed in a  
// user-defined function.  
#include <iostream>  
using namespace std;  
  
void getAnswers (int num1, int num2, int &total, int &prod);  
  
int main()  
{  
    int x1, x2, sum, product;  
  
    // Prompt for input  
    cout << "Enter two integers ->";  
    cin >> x1 >> x2;  
  
    // Call function to do the calculations  
    getAnswers(x1, x2, sum, product);  
  
    // Print results  
    cout << "The integers are " << x1 << " and " << x2 << endl;  
    cout << "Their sum is " << sum << endl;  
    cout << "Their product is " << product << endl;  
  
    return 0;  
}  
void getAnswers (int num1, int num2, int &total, int &prod)  
// Function getAnswers calculates the sum and product of  
// its first two parameters and places the answers  
// in the third and fourth parameters  
{  
    total = num1 + num2;  
    prod = num1 * num2;  
}
```

Figure 4a

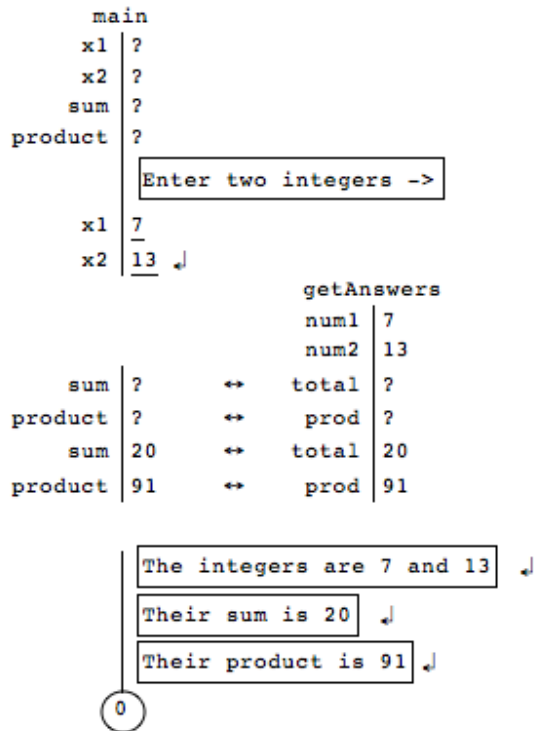


Figure 4b

---

Returning values from a function in Java to a calling program can be accomplished using accessor methods of a class. For example, the Java program shown in Figure 5 prompts the user for the length and width of a rectangle, and calculates and prints the area and perimeter.

The student must learn to frame problems in terms of classes in order to succeed in Java. Although C++ programs may also be constructed using multiple files, it is hardly possible to write a substantial program in Java without multiple files, as each public class must be contained in a separate file. Any tracing implementation for Java should emphasize the shifting from one file to another during execution of a multi-file program.

---

```

public class Rectangle{
    private double length, width;
    private double area, perimeter;

    public Rectangle(){
    }

    public void getDimensions(){
        System.out.print("Enter length and width:");
        Scanner myInput = new Scanner(System.in);
        String inString = myInput.next();
        length = Double.parseDouble(inString);
        inString = myInput.next();
        width = Double.parseDouble(inString);
    }

    public void doCalculations(){
        area = length * width;
        perimeter = 2.0 * (length + width);
    }

    double getArea(){
        return area;
    }

    double getPerimeter(){
        return perimeter;
    }
}

public class Main{
    public static void main(String args[]){
        Rectangle r = new Rectangle();
        r.getDimensions();
        r.doCalculations();
        System.out.println("Area = " + r.getArea());
        System.out.println("Perimeter = " + r.getPerimeter());
    }
}

```

```

main
args | null
r | null
      ADDR0.Rectangle
      ADDR0.length | 0.0
      ADDR0.width | 0.0
      ADDR0.area | 0.0
      ADDR0.perimeter | 0.0

r | ADDR0
      ADDR0.getDimensions
      | Enter length and width:
myInput | null
myInput | ADDR1
inString | ""
      ADDR1.next
      | "3.2"
inString | "3.2" ↓
ADDR0.length | 3.2
      ADDR1.next
      | "2.5"
inString | "2.5" ↓
ADDR0.width | 2.5

|
      ADDR0.doCalculations
      ADDR0.area | 8.0
ADDR0.perimeter | 11.4

|
      ADDR0.getArea
      | 8.0

| Area = 8.0 ↓
      ADDR0.getPerimeter
      | 11.4

| Perimeter = 11.4 ↓

```

Figure 5

The importance of object references in Java makes it worth examining whether or not a Java program using an array of objects can be traced without adding complexity. The program of Figure 6 creates an array of elements of the Student class, and prompts for a name and grade for each of the elements. It calculates and prints an average and then a list of those students whose grades are above that average.

The array of Students is declared in the statement

```
Student [] sts = new Student[numStudents];
```

The trace of this statement shows that sts is initially null:



```
sts | null
```

space is allocated for an array of 3 elements of type Student, or more accurately, an array of 3 object references, whose initial values are listed sequentially in the trace:

```
ADDR1 | null null null
```

and finally a reference to that array is assigned to sts:

```
sts | ADDR1
```

Each time the statement

```
sts[i] = new Student();
```

is executed, a new Student object is created and a reference to it is assigned to one of the elements of the array sts. Figure 6 shows that after creation of the first Student object, the elements of the array referenced by sts are ADDR2, null, and null.

---

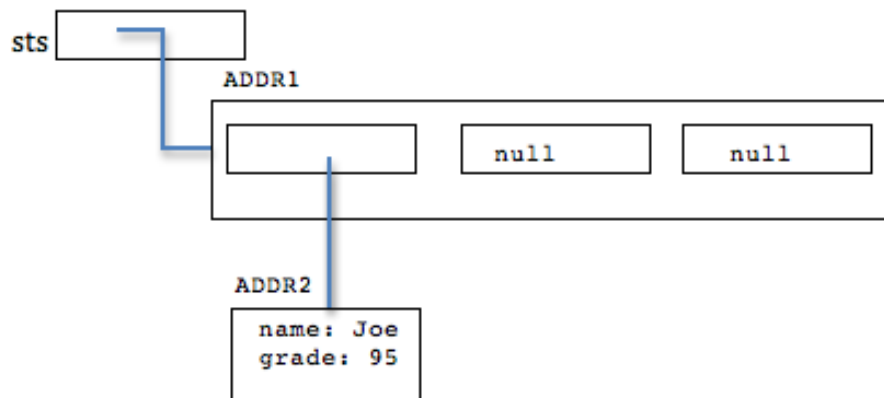


Figure 6

---

It is interesting that Figure 6 is representative of the kind of figure often found in elementary Java texts. The student can follow the trace of Figure 7 and draw a similar figure.

---

```

// This program prompts the user for the names and grades of
// three students and prints the names of those above average
public class Student
{
    static Scanner console;

    public static void main(String[] args) {
        final int numStudents = 3;
        console = new Scanner(System.in);
        Student [] sts = new Student[numStudents];
        int sum = 0, i;
        for (i = 0; i < numStudents; i++){
            sts[i] = new Student();
            sum += sts[i].getGrade();
        }
        double avg = (double) sum / numStudents;
        System.out.println("Average = "
            + Math.round(10.0 * avg) / 10.0);
        System.out.print("Above average students:");
        for (i = 0; i < numStudents; i++)
            if (sts[i].getGrade() > avg)
                System.out.print(sts[i].getName() + " ");
        System.out.println();
    }

    String name;
    int grade;

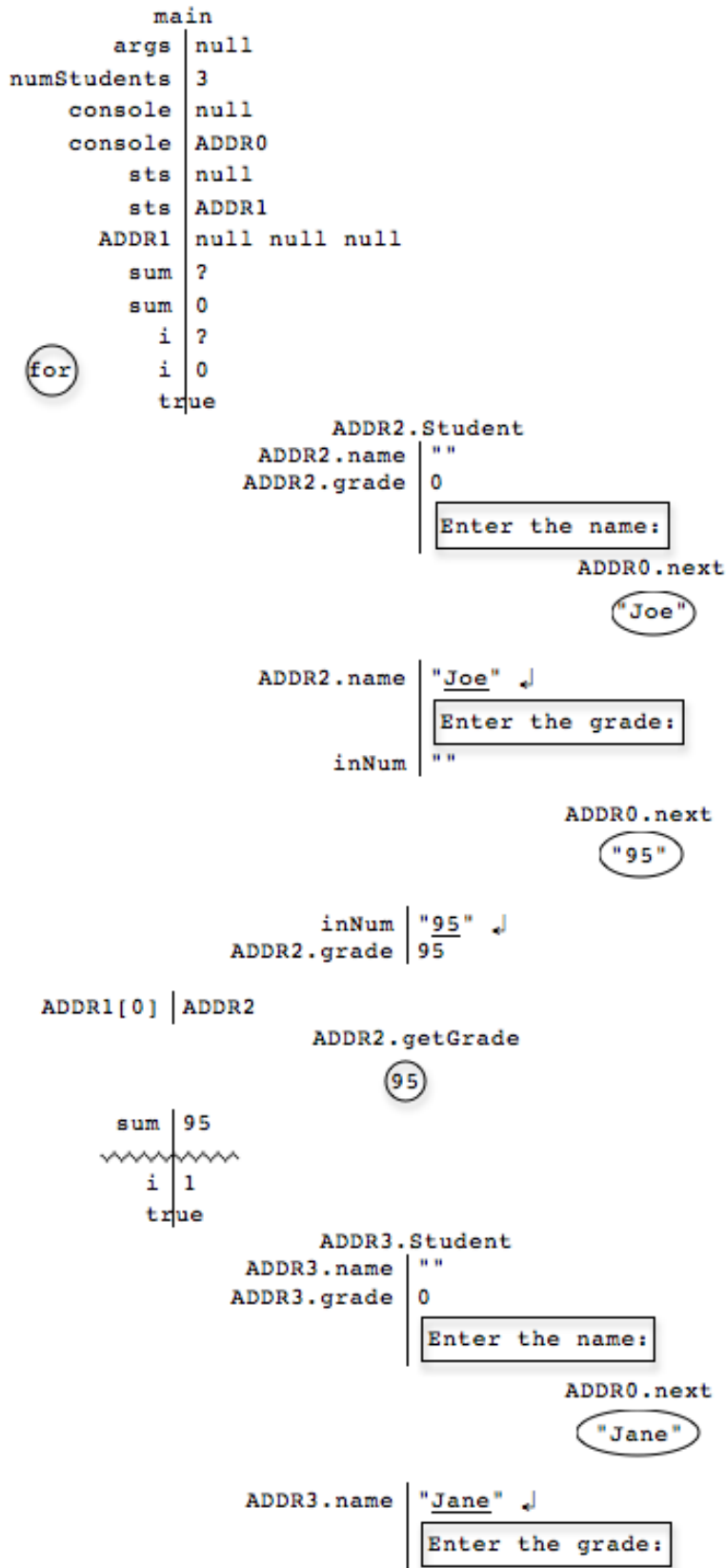
    public Student(){
        System.out.print("Enter the name:");
        name = console.next();
        System.out.print("Enter the grade:");
        String inNum = console.next();
        grade = Integer.parseInt(inNum);
    }

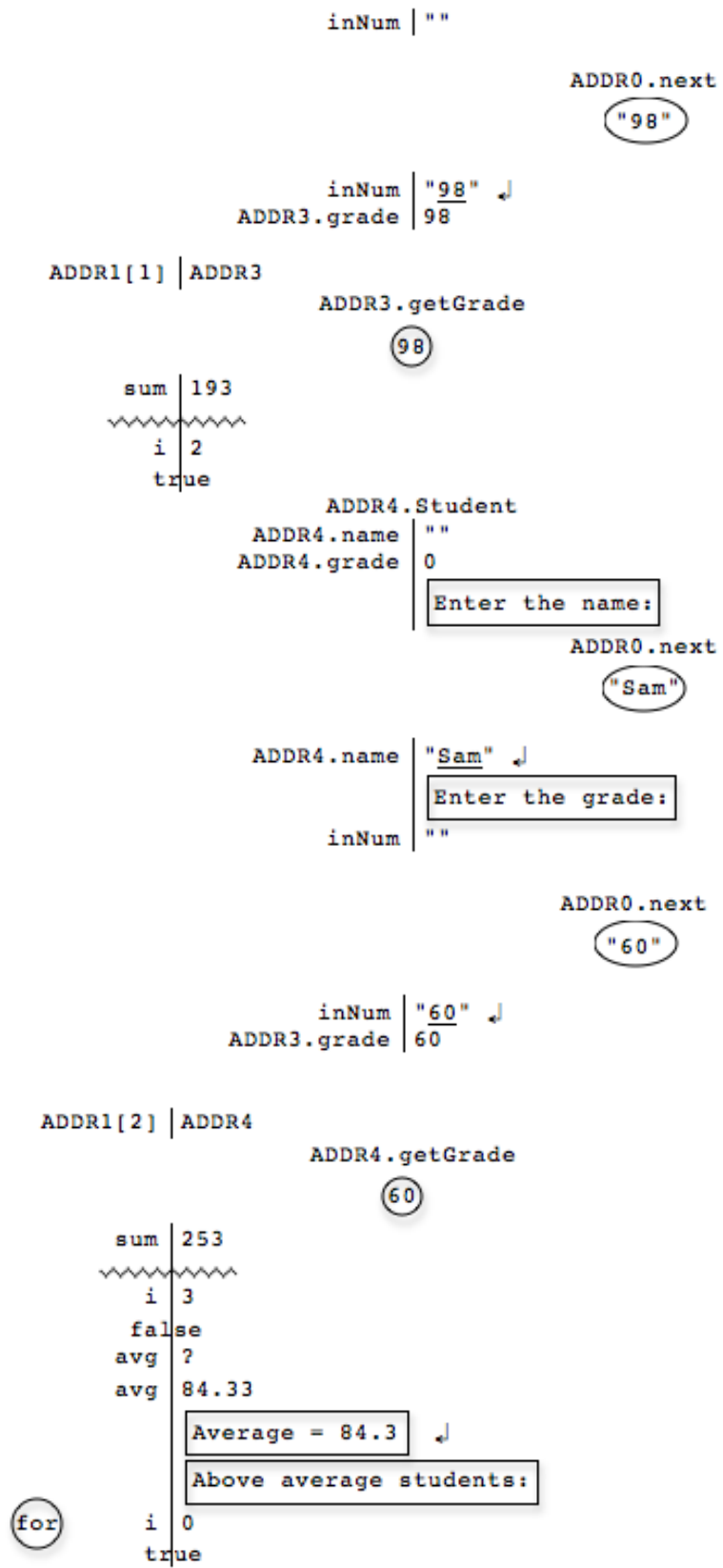
    public void display(){
        System.out.println("Name:" + name + ", Grade:" + grade);
    }

    public int getGrade(){
        return grade;
    }

    public String getName(){
        return name;
    }
}

```





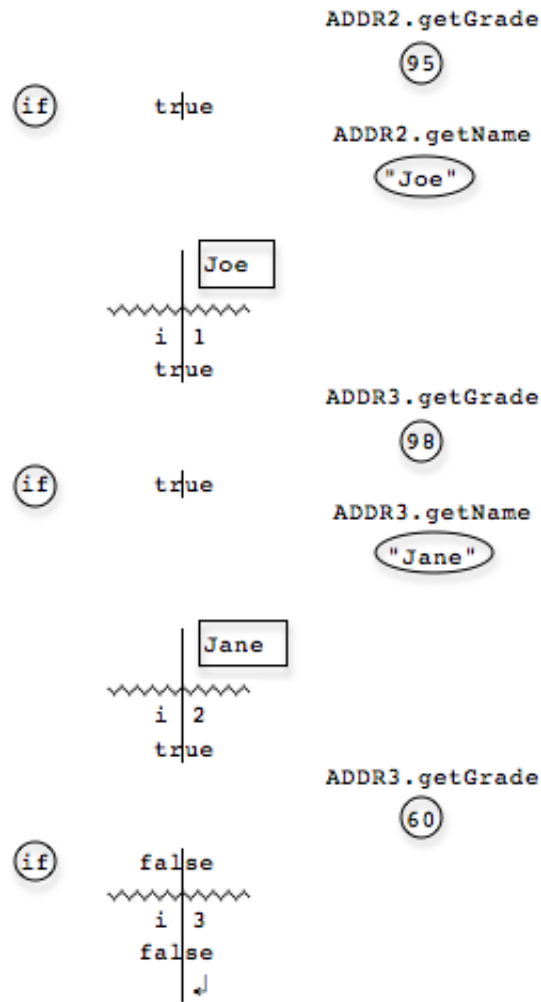


Figure 7

---

## Exceptions and interrupts

The graphical user interface of Java requires that the student be able to handle exceptions and interrupts effectively. When a Java program reads input that is formatted incorrectly, for example, it must handle the resulting exception in a way that allows the user to re-enter the input. The program of Figure 8a prompts the user for two integers and adds them; in Figure 8b, the first input value, 251, is entered correctly, but the user first mistakenly enters \*37 for the second input value and then enters 37 when the program detects the error.

---

```

public class InputNum {

    static Scanner console;
    int theInputNum;

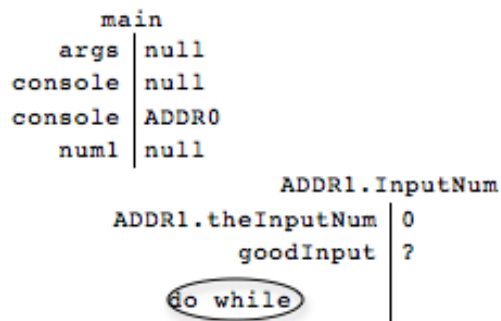
    public static void main(String [] args){
        console = new Scanner(System.in);
        InputNum num1 = new InputNum(),
            num2 = new InputNum();
        int val1 = num1.getNum(),
            val2 = num2.getNum(),
            sum = val1 + val2;
        System.out.println("Sum = " + sum);
    }

    public InputNum(){
        Boolean goodInput;
        do{
            goodInput = true;
            try{
                System.out.print("Enter an integer:");
                String inString = console.next();
                theInputNum = Integer.parseInt(inString);
            }
            catch (NumberFormatException e){
                System.out.println("Bad input");
                System.out.println();
                goodInput = false;
            }
        } while(!goodInput);
    }

    int getNum(){
        return theInputNum;
    }
}

```

Figure 8a



```

goodInput | true
(try)
Enter an integer:
inString | ""

```

ADDR0.next

"251"

```

inString | "251" ↓
ADDR1.theInputNum | 251
e | null
(catch) | false
| false
~~~~~

```

```

num1 | ADDR1
num2 | null

```

ADDR2.InputNum

```

ADDR2.theInputNum | 0
goodInput | ?

```

(do while)

```

goodInput | true

```

(try)

Enter an integer:

```

inString | ""

```

ADDR0.next

"\*37"

```

inString | "*37" ↓
e | "...exception... *37"
(catch) | true

```

Bad input ↓

```

goodInput | false
| true

```

~~~~~

```

goodInput | true

```

(try)

Enter an integer:

```

inString | ""

```

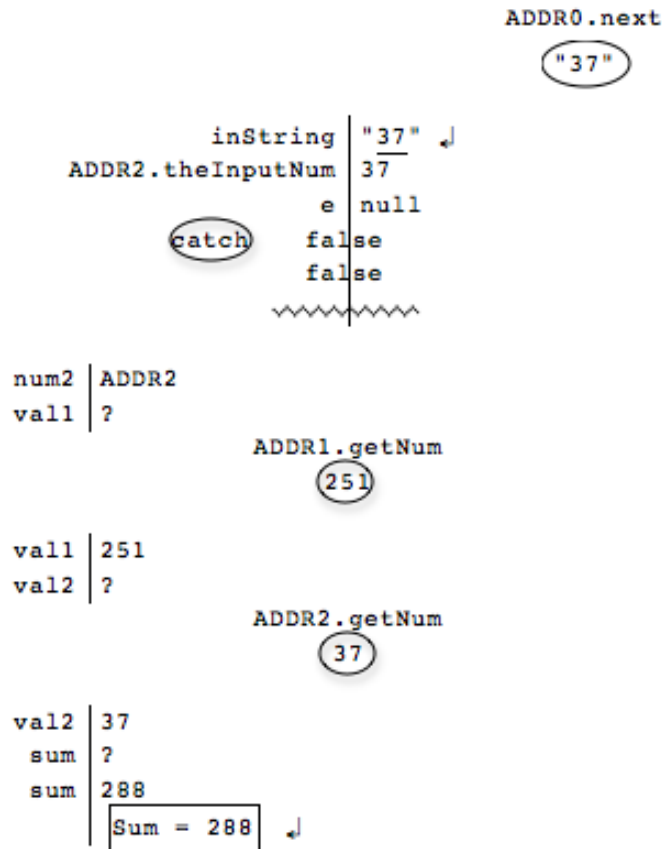


Figure 8b

---

### Copying objects

A topic that is of particular interest in Java programming is the various ways of copying objects. At issue is the question of whether the tracing method can help the student understand the differences among the various techniques.

The program of Figure 9 illustrates some of the methods. In the sequence

```
Triangle t1 = new Triangle(10.0, 15.0, 9.0);
```

```
Triangle t2 = t1;
```

a triangle object, t1, is created and a new object, t2, is set to reference it. In the further sequence

```
Triangle t3 = new Triangle();
```

```
t3.copyTriangle(t1);
```

t3 is created with the default sides of 0.0, 0.0, and 0.0, and then by means of the Triangle method copyTriangle takes on the values of the sides of t1. Finally, t4 is created, and the function copyTriangle (not the method) is invoked with actual parameters t4 and t1, ostensibly to copy t1 into t4. However, the formal parameters of copyTriangle are copies of the actual parameters and there is no effect on t4.

---



```

public class Main {
    public static void main(String[] args) {
        Triangle t1 = new Triangle(10.0, 15.0, 9.0);
        Triangle t2 = t1;
        t1.display("t1");
        t2.display("t2");
        Triangle t3 = new Triangle();
        t3.copyTriangle(t1);
        t3.display("t3");
        Triangle t4 = new Triangle();
        copyTriangle(t4, t1);
        t4.display("t4");
    }
    public static void copyTriangle(Triangle ta, Triangle tb){
        ta = tb;
    }
}

public class Triangle {
    double side1, side2, side3;
    public Triangle(double s1, double s2, double s3){
        side1 = s1; side2 = s2; side3 = s3;
    }
    public Triangle(){
    }
    public void display(String tnum){
        System.out.println("Triangle " + tnum + " -- Sides: " + side1
            + ", " + side2 + ", and " + side3);
    }
    public void copyTriangle(Triangle t){
        side1 = t.side1; side2 = t.side2; side3 = t.side3;
    }
}

```

```

main
args | null
t1 | null

      ADDR0.Triangle
ADDR0.side1 | 0.0
ADDR0.side2 | 0.0
ADDR0.side3 | 0.0
      s1 | 10.0
      s2 | 15.0
      s3 | 9.0
ADDR0.side1 | 10.0
ADDR0.side2 | 15.0
ADDR0.side3 | 9.0

t1 | ADDR0
t2 | null
t2 | ADDR0

      ADDR0.display
      | Triangle t1 -- Sides:10.0, 15.0, and 9.0 ↵

|

      ADDR0.display
      | Triangle t2 -- Sides:10.0, 15.0, and 9.0 ↵

t3 | null

      ADDR1.Triangle
ADDR1.side1 | 0.0
ADDR1.side2 | 0.0
ADDR1.side3 | 0.0

t3 | ADDR1

      ADDR1.copyTriangle
      t | ADDR0
ADDR1.side1 | 10.0
ADDR1.side2 | 15.0
ADDR1.side3 | 9.0

|

      ADDR1.display
      | Triangle t3 -- Sides:10.0, 15.0, and 9.0 ↵

t4 | null

      ADDR2.Triangle
ADDR2.side1 | 0.0
ADDR2.side2 | 0.0
ADDR2.side3 | 0.0

```

```

t4 | ADDR2
    copyTriangle
      ta | ADDR2
      tb | ADDR0
      ta | ADDR0
    |
    ADDR2.display
    |
    | Triangle t4 -- Sides:0.0, 0.0, and 0.0
    |
    |

```

Figure 9

---

### Conclusions

Tracing accounts for many of the features of Java that would be taught to beginning programmers or to students who have had a background in C++. The analysis has touched only lightly on the graphical user interface that is a major part of Java courses; a more detailed analysis might indicate that tracing operations in that environment would resemble those of the exception handling example in Figure 8.

Tracing focuses the student's attention on one step of a program at a time. It can be useful to an instructor who is explaining the execution of some programs, and it can be useful to students who are following the execution of programs that are known to execute correctly. It is not clear whether or how tracing helps students write their own programs. In fact, studies are contradictory whether it is even necessary that students be able to trace programs others have written in order to write their own programs (see Warms<sup>3</sup> for references).

While understanding the techniques covered by the tracing examples might be a necessary step toward having a good knowledge of a language, it is certainly not a sufficient condition. The hope is that using tracing helps a student master basic material and become better able to learn additional material. It may assist students in learning how to understand the use of classes and in dealing with many other features of that language. It is likely that programs that incorporate these features may be traced using the same principles that were used in tracing C++ programs, without introducing complex new notations.

### Bibliography

- [1] T. M. Warms and R. Drobish, "Tracing the execution of computer programs – report on a classroom method," in Proceedings of the Spring 2007, ASEE Mid-Atlantic Section Conference, Newark, NJ. (CD-ROM proceedings).
- [2] T. M. Warms, "The Semantics of Tracing: Transitivity of Reference," Proceedings of FECS'07 — The 2007 International Conference on Frontiers in Education: Computer Science and Computer Engineering, Las Vegas, June 2007, pp. 302 – 307

- [3] T. M. Warme, "Using the tracing method and RandomLinearizer for Teaching C++," in Proceedings of the FECS'10 — The 2010 International Conference on Frontiers in Education: Computer Science and Computer Engineering, Las Vegas, NV. pp. 16-22.
- [4] T. M. Warme, Qiang Duan, and Kavon Farvardin, "Can Using a Formal System For Tracing Computer Programs Help Students Learn Introductory Computer Science?"
- [5] B. Eckels, "Thinking in Java". Prentice Hall, Englewood Cliffs, NJ, fourth ed. (2006).

## **Bringing Concurrent Engineering into Classroom through Multidisciplinary Product Design Project - Design and Construction of Chemical Detection Robots**

Andy S. Zhang,

Department of Mechanical Engineering Technology, NYC College of Technology

Farrukh Zia

Department of Computer Engineering Technology, NYC College of Technology

Iem Heng

Department of Computer Engineering Technology, NYC College of Technology

### **ANDY S. ZHANG**

Professor Andy S. Zhang earned his master's in mechanical engineering from the City College of New York in 1987 and his Ph.D. in mechanical engineering from the Graduate Center of the City University of New York in 1995. Prior joining the Mechanical Engineering Technology department at City Tech in 2000, he served as an engineering instructor for the JUMP, an engineering training program sponsored by the New York State Department of Transportation. Professor Zhang's research area includes materials testing, composite materials, CAD/CAE, robotics and mechatronics, and engineering technology education.

### **FARRUKH ZIA**

Professor Farrukh Zia earned his master's and PhD in computer engineering from Syracuse University in 1988 and 1996, respectively. Before he joined the CET/EMT department of New York City College of Technology in 2002, he worked for Lucent Technologies in New Jersey as a member of the technical staff. Zia's PhD research work was related to the applications of neural networks and fuzzy logic in controlling non-linear dynamic systems. His current research activities include applications of neural networks and fuzzy logic in industrial control systems and robotics.

### **IEM HENG**

Professor Iem Heng earned his bachelor's degree from Providence College (Providence, RI) with double majors in Pre-Engineering Program and mathematics. In addition, he earned another bachelor's degree from Columbia University (New York, NY) in mechanical engineering and master's in applied mathematics from Western Michigan University (Kalamazoo, MI); his Ph.D. in computational and applied mathematics from Old Dominion University (Norfolk, VA). Before joining the EMT/CET department at City Tech in fall of 2007, he was a faculty member and chair of the CET department at DeVry Institute of Technology (Long Island City, NY). He worked as a researcher for NASA Langley Base in Hampton, VA, for 2 years. His research activities include embedded systems, software development for embedded systems with real time simulation, real time gaming simulation programming, and web application programming.

# ***Bringing Concurrent Engineering into Classroom through Multidisciplinary Product Design Project - Design and Construction of Chemical Detection Robots***

## **Abstract**

This paper presents a study on how to utilize hands-on design project to simulate the actual concurrent engineering practice adopted by the companies when designing and developing new products. Students from the departments of mechanical engineering technology and computer engineering technology at the New York City College of Technology of CUNY were involved in this multi-disciplinary design project called Design and Construction of Chemical Detection Robot (DCCDR).

For the past two decades, the concurrent engineering approach and product life cycle management philosophy have enabled many companies to shorten product development life cycle, improve the quality of their products and to be competitive in the fast-pace product design and development markets [1, 2]. The goal of this DCCDR project is, through the hands-on multi-disciplinary design activities with the help of concurrent engineering approach and life cycle management engineering software, to help students to master the arts and science on how to engage in the product design and development in the 21<sup>st</sup> century; to help the students to form new perspectives in solving engineering problems and dealing with issues associated with product design and development such as team work, time management, and balance between people skills and technical skills.

Because of the time constraints in the classroom setting, this paper addresses two important components related to product design: engineering design components and project management components. The engineering design component consists of mechanical design, electrical and electronic design, and software design. The project management component addresses the issues on how to form effective concurrent engineering team, what organization forms best support the innovative needs of concurrent engineering, time management, how to select team leaders and team members.

This research collaborative work in concurrent engineering among the faculty members in the Mechanical Engineering Technology and Computer Engineering Technology departments is funded by the National Science Foundation Advanced Technology Education Division (Award No. DUE-1003712) recently awarded to New York City College of Technology.

## **Introduction**

Over the past twenty years, concurrent engineering has emerged as the preferred systematic engineering approach and the de facto business strategy to solve engineering problems by companies large and small. It has been proven that concurrent engineering increases productivity and product quality, and optimizes product design and development cycles [1-3]. Concurrent engineering has become the preferred approach for high tech companies to compete in the global product design and development field. It requires the tight integration of all resources, effective collaboration among various engineering departments at the onset of a project, and demands that engineering activities engaged by various departments be conducted concurrently to minimize the errors and optimize the product. In order to expose students to the latest concurrent engineering approach and to help them to gain valuable experience in product design and development areas, faculty members from the departments of mechanical engineering technology and computer engineering technology have developed a hands-on design project called Design and Construction of Chemical Detection Robot (DCCDR). The DCCDR project contains three major components: engineering component, project management component, and project assessment and evaluation component.

The modern concurrent engineering requires the product design team to take into consideration in the early design phases, the product's life cycle when designing or choosing its components based on product's functionality, cost, manufacturability, easiness in assembly, testability, easiness in maintenance, environmental impact, disposal, and recycling [3,4]. These considerations are turned into design features, manufacturing features, assembly features, maintenance features, and recycles features that each student has to address when designing or choosing a component.

Various design constraints such as temporal constraints and spatial constraints were introduced to help students to plan design activities to decide which activities can occur at the same time, or concurrently. Project management software such as Microsoft Project is being used to help students to plan their design activities. Students were informed the ultimate goal of using concurrent approach is to significantly increase the productivity and product quality that are vital for companies to survive in today's fast-paced market economy [5].

Concurrent engineering allows errors be found and redesigns be made early in the design process when the project is still in its infancy stage and possibly in its digital realm thus avoiding costly remedies in fixing these errors as the project moves to more complicated computational models and eventually into the physical production [6-12].

### **Engineering Design Components**

The engineering component of this project contains major product design elements consisting of mechanical design, electrical/electronic design, and software design. In the classroom setting, not all elements of a product design can be discussed and implemented because of limited resources and time constraint. The mechanical design includes design of robot chassis, differential system, and steering system. Students were taught to take into consideration of all the features in design, manufacturing, assembly, maintenance, and recycles when designing or choosing a component to optimize the design.

The electrical and electronics design includes selection of robot controller, chemical sensors, wireless communication tools, and design of electrical/electronic circuits.

The software design includes the development and testing of robot control algorithms and source codes. The scope of the engineering work reflects actual engineering activities in the industry related to product design and development.

The concepts of temporal constraints and spatial constraints were introduced to help students to consider the life cycle issues in the product design. Students were asked what task has to be done first and what tasks can be proceeded concurrent to shorten the time

Various computer software packages were used to simplify and to communicate design ideas among team members.

### **Mechanical Design**

3D CAD software package are being utilized to produce digital models for three mechanical systems: chassis, differential drive train, and steering system. The mechanical design team was divided into three sub groups: Chassis Design group, Differential drive group, and Steering system group. Members in each group are taught to be mindful of the geometric constraints among the three systems.

In chassis design, students are required to use sheet metal to come up with a pattern, when bend into shape, has enough rigidity to support the whole weight of the robot. The geometry of the chassis

depends on the size of the wheels, the DC and servo motors to be used, the wheel base and the dimension between the front and rear axles. Figure 1 shows one chassis design which reflects the space consideration and other design specifications. Figure 2 is an actual chassis made of sheet metal which size has been increased to have enough space for other components.

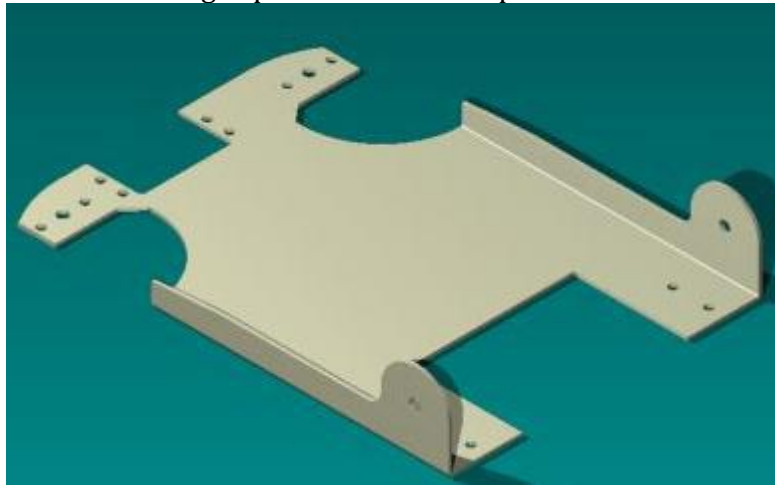


Figure 1: A typical chassis design using sheet metal



Figure 2: An actual chassis made of sheet metal

In differential drive train design, students learn the principles of gears and power train. Since the size of the differential gearbox depends on the size of DC motor, the dimension of wheel base, the wheel size, and the chassis geometry, students need to consult with chassis design team constantly when changes are made in either team. Figure 3 shows one model of the differential gearbox design.



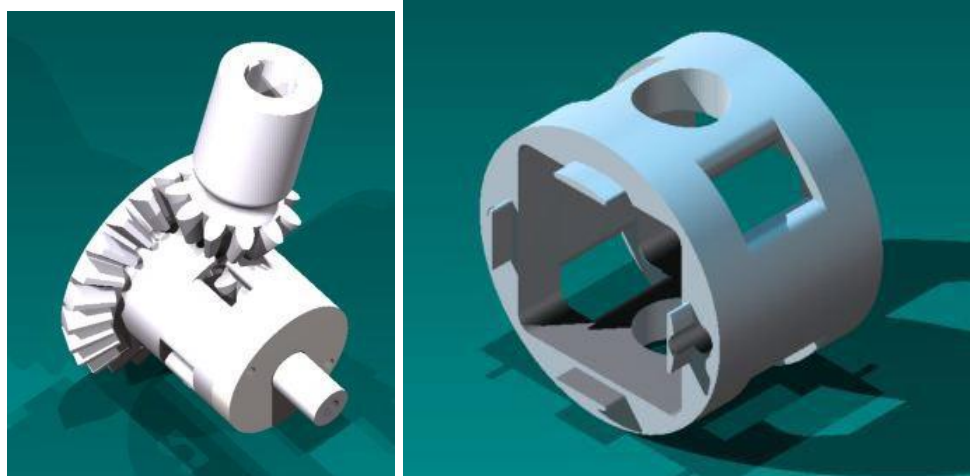


Figure 3: Differential Drive Design

In steering system design, students utilize the knowledge they learn from kinematics. They can use a four-bar linkage or rack and pinion to come up with the steering system. Since the steering system is driven by a servo motor, students preferred using four-bar linkage to make their design. Figure 4 is one of the student team's design.

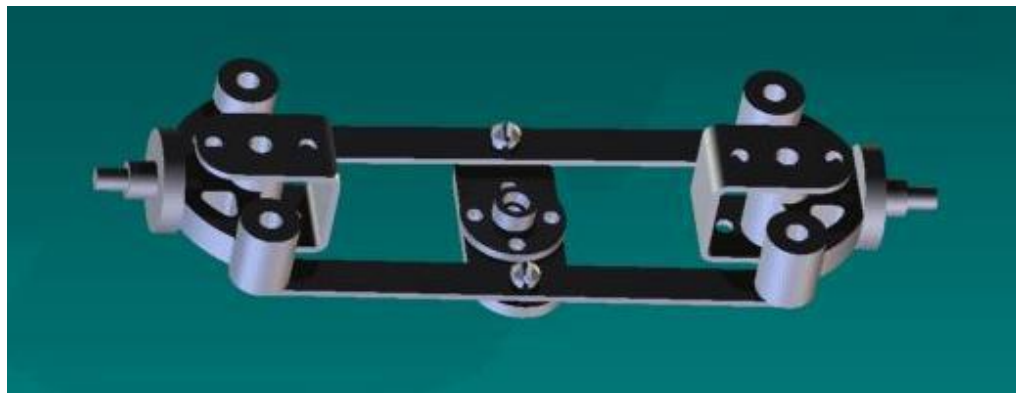


Figure 4: Steering System Design

The challenge was that four-bar parallel system does not guarantee the two steering wheels always have tangential speed with respect the instant turning center. In the new steering system design, students are required to incorporate the Ackermann Angle principle [13] as shown in Figure 5 when designing the four-bar linkage.

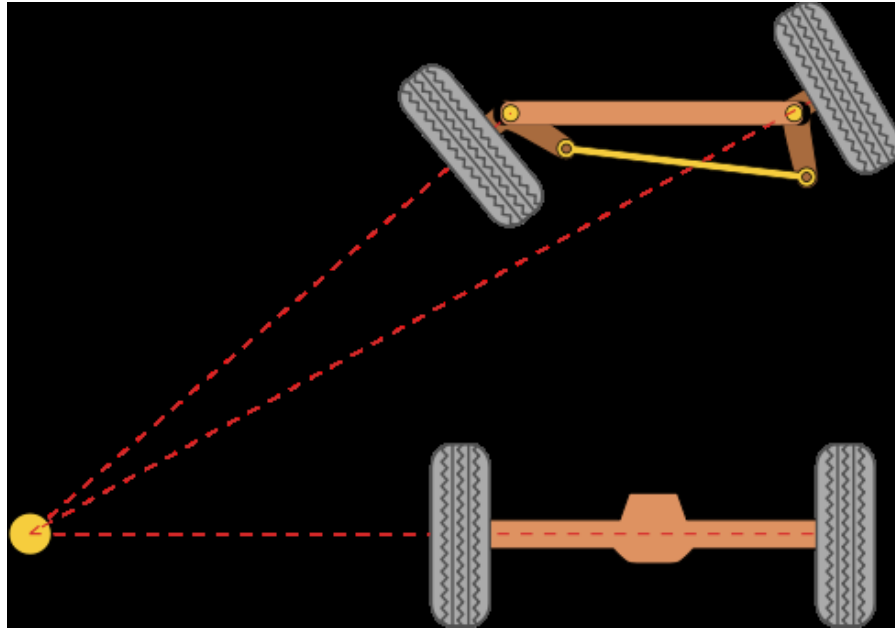


Figure 5: Ackermann Angle

### Electrical/electronic Design

Students in the computer engineering technology are responsible to design the electrical and electronic circuit for the robots. Arduino micro-controllers are being used for the circuit design.

Figure 6 is the design of electronic circuit to be mounted on the robot. It is powered by a 12 volt battery. A voltage regular is used to supply 5 volt power to Arduino micro-controller. The circuit board contains circuits to interface with two chemical sensors, one 12 volt DC motor with relays, one servo, and one ZigBee radio chip.

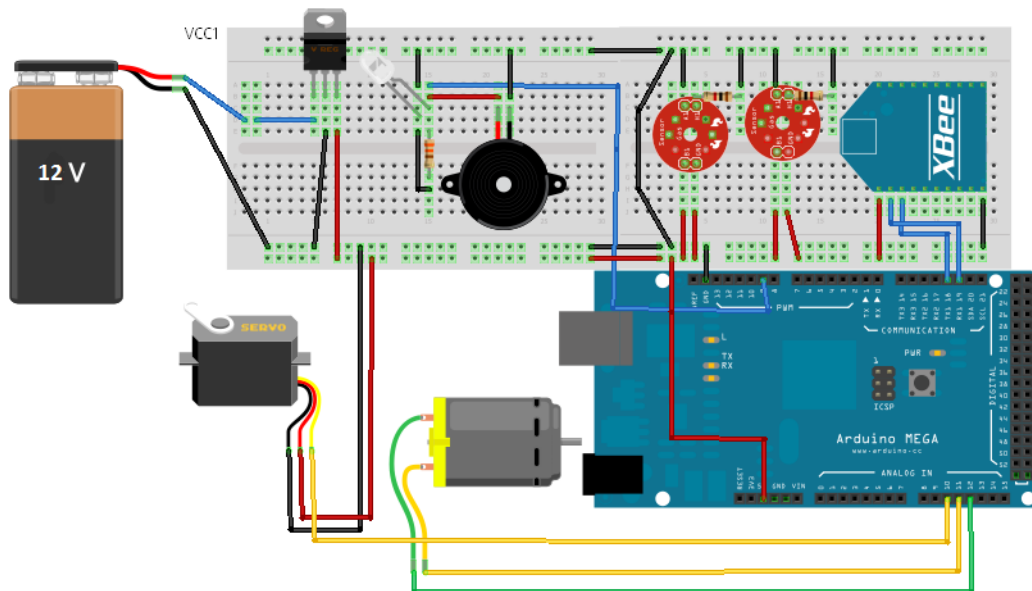


Figure 6: Circuit Design on Robot

Figure 7 is the circuit design for the remote control unit. The unit is powered by a 5 volt battery. The remote control unit contains circuit to interface with a joystick, a sound buzzer, an LED light, a LCD screen, and a ZigBee radio chip.

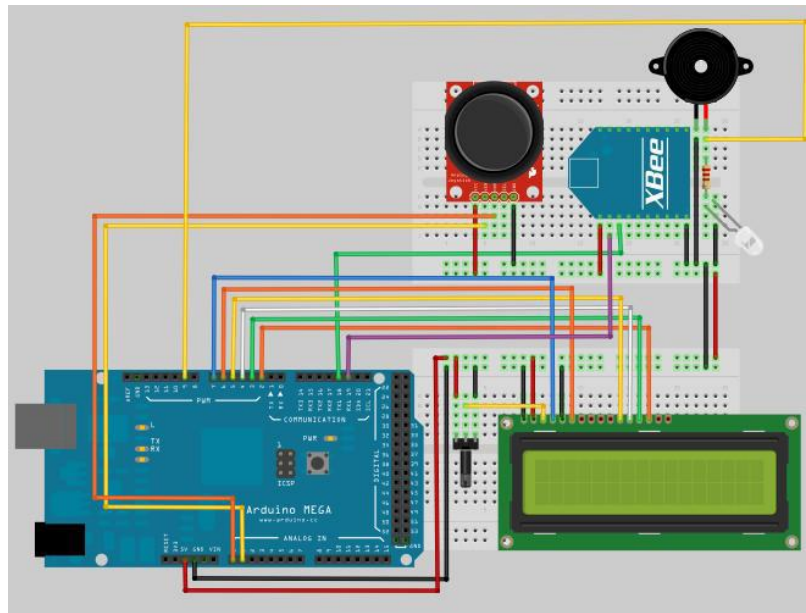


Figure 7: Circuit Design on Remote Control Unit

### Software Design

Design and development of control software is an important part of this project. The DCCDR software is written in Arduino sketch programming language (similar to C language) and consists of two distinct programs. The DCCDR Controller Program runs on the Arduino MEGA controller board, mounted on the robot chassis and the DCCDR Remote Unit Program runs on the Arduino MEGA controller board, mounted on the handheld remote unit. The two controllers communicate with each other using ZigBee wireless communication protocol. The Remote Unit sends motor control and steering commands to the Robot Controller and the Robot Controller sends chemical sensor data to the Remote Unit. A warning buzzer on the Remote Unit indicates the presence of chemicals above a threshold value. Figure 8 is the program flow chart of DCCDR controller.

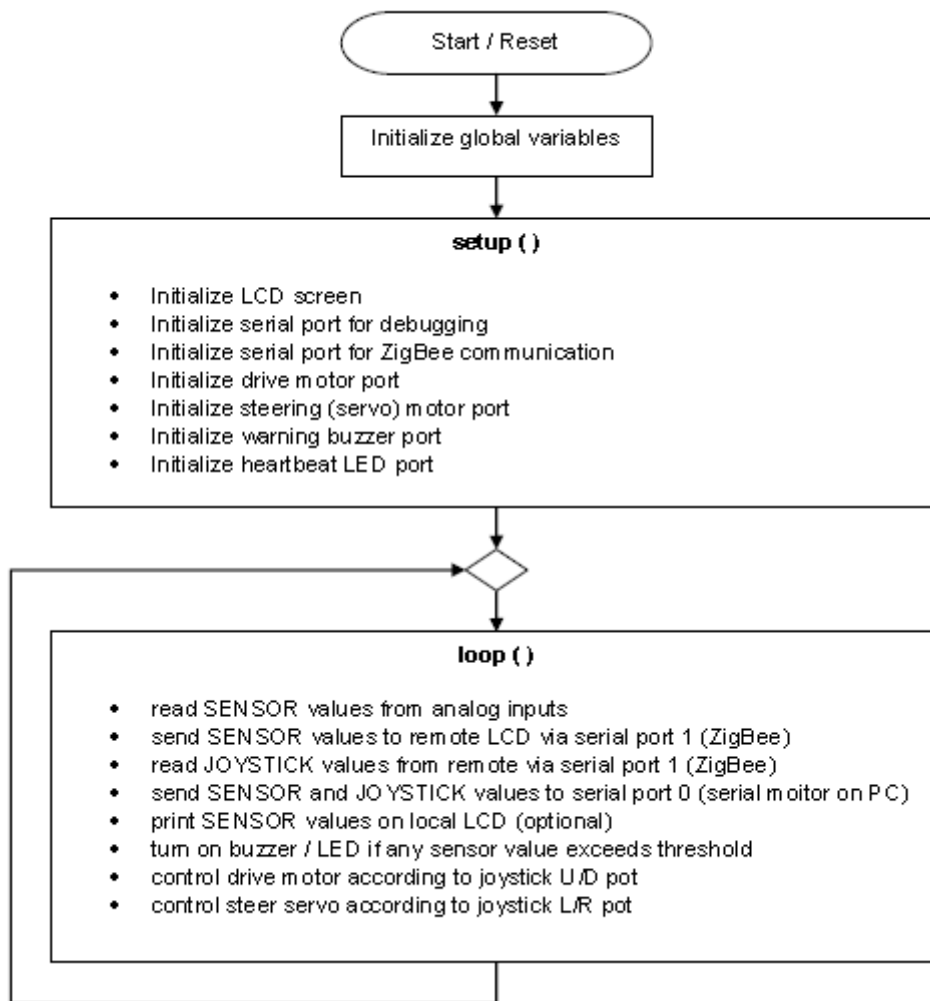


Figure 8: DCCDR Controller Program Flow Chart

The software design and development activities are carried out with the help of standard techniques and tools such as UML activity diagrams and flow charts, top down and bottom up design methods and software design cycle rules. Testing and debugging of software is carried out by following a modular and incremental approach. Figure 9 is the program flow chart of DCCDR remote control unit.

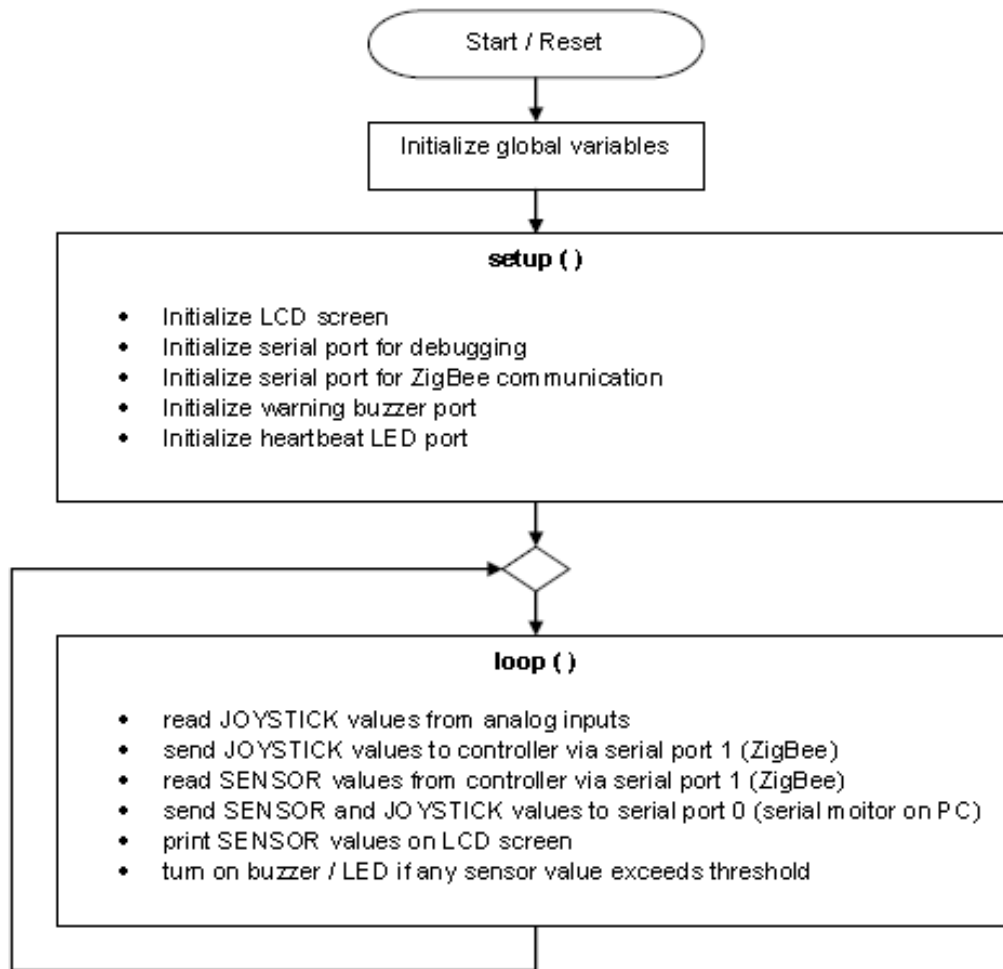


Figure 9: DCCR Remote Unit Program Flow Chart

## Project Management Components

The project management component addresses the issues on how to form effective concurrent engineering team, what organization forms best support the innovative needs of concurrent engineering, how to select team leaders and team members.

Before students were given the design projects, they were informed the importance of forming a concurrent engineering team. An effective concurrent engineering team must have three key attributes:

1. They must be able to deal with the inherent uncertainties related to innovation.
2. They must have among themselves or willing to obtain during the design process, a broad range of professional knowledge and skills in design theories, engineering principles, scientific reasoning, manufacturing, marketing and financing.
3. They must be willing to share knowledge and collaborate professionally.

## Choosing Team Leaders

Attributes to be a good team leader were discussed. Students were encouraged to nominate themselves first to be the team leaders. The candidates were then interviewed by the instructor to make final decision. The team leaders are responsible to hold group meetings, to generate plans, and report to instructors on a weekly base.

### **Selection of Team Members**

Once selected as the team leader, he or she will start interview fellow classmates to choose the members for the team. This simulates the actual hiring process occurred in companies and gives students insights on the hiring process. Each team member is assigned a task to do. He or she needs to report to the team leader on the progress and problems encountered when it happens.

The process of selecting team leaders and team members help each student to reaffirm his or role in the team.

### **Project Assessment Components**

Project assessment and evaluation component discusses the needs for effective assessment of the approach used in this project. Both pre-engineering design self-efficacy survey and post engineering design self-efficacy survey tools were used. Formative and summative assessments tools for the project have developed and used to measure the effective of this project.

Instructors will use the Design Strategies Matrix developed by Dr.Crismond [14] as a rubric to assess students' growth in using select design strategies in an "informed" way. Based on monthly observations of student working in teams, individual's growth in design capability will be reported. Table 1 (next page) shows the Design Strategies Matrix. It links 10 Patterns of Design Behaviors (Column 2) to descriptions of how Beginning Designers (Column 3) versus Informed Designers (Column 4) do those strategies or habits of mind.

Table 1: The Design Strategies Matrix

|                                           | PATTERNS                                                | DESCRIPTIONS OF PATTERNS                                                                                            |                                                                                                                                |
|-------------------------------------------|---------------------------------------------------------|---------------------------------------------------------------------------------------------------------------------|--------------------------------------------------------------------------------------------------------------------------------|
|                                           | BEGINNER VS INFORMED DESIGNERS                          | WHAT BEGINNING DESIGNERS DO                                                                                         | WHAT INFORMED DESIGNERS DO                                                                                                     |
| EXPLORE THE CHALLENGE & GENERATE IDEAS    | A. Problem Solving VS Problem Framing                   | Treat design task as a well-defined problem and make decisions prematurely, often right after reading design brief. | Delay making design decisions in order to explore, understand and frame the design problem.                                    |
|                                           | B. Skipping VS Doing Research                           | Skip doing research and instead pose or build solutions immediately.                                                | Do research and hands-on investigations to learn about the problem and how things work.                                        |
|                                           | C. Idea Fixation VS Idea Fluency                        | Get stuck on their first design ideas that they won't let go of.                                                    | Practice idea fluency via brainstorming, sketching, and rapid prototyping.                                                     |
|                                           | D. Surface VS Deep Drawing & Modeling                   | Sketch ideas or make models of devices that would not work if built.                                                | Use words, drawings and models to explore ideas and show how things work.                                                      |
| CHOOSE, TEST & IMPROVE IDEAS & PROTOTYPES | E. Ignore VS Balance Benefits & Tradeoffs               | Attend only to positive traits of favored ideas, and notice only drawbacks of lesser approaches.                    | Weigh both benefits and tradeoffs of all ideas before deciding on an approach to solving the design challenge.                 |
|                                           | F. Confounded VS Valid Tests & Experiments              | Do few or no prototype tests or run confounded experiments                                                          | Do valid experimental tests to learn about materials and key design variables or optimize performance.                         |
|                                           | G. Unfocused VS Diagnostic Troubleshooting              | Use a generalized, unfocused way to troubleshoot ideas during testing.                                              | Focus attention on key problem areas when diagnosing and troubleshooting ideas or devices.                                     |
| USE EFFECTIVE DESIGN HABITS               | H. Solitary or Dominating VS Collaborative Design Work  | Team members work in isolation OR individuals dominate the group's work and decision making.                        | Members of team collaborate in performing different project roles and negotiate when making key design decisions.              |
|                                           | I. Haphazard or Linear VS Managed & Iterative Designing | Designing is done haphazardly OR steps are done once in linear order.                                               | Do design in a managed way, where ideas are improved iteratively via feedback, and strategies are used in any order as needed. |
|                                           | J. Tacit VS Reflective Thinking                         | Do tacit designing with little self-reflection or monitoring of actions.                                            | Practice reflective thinking by keeping tabs on design work and thinking.                                                      |

## Results

Figure 10 is the computer rendering of the remote control unit and the chemical detection robot.

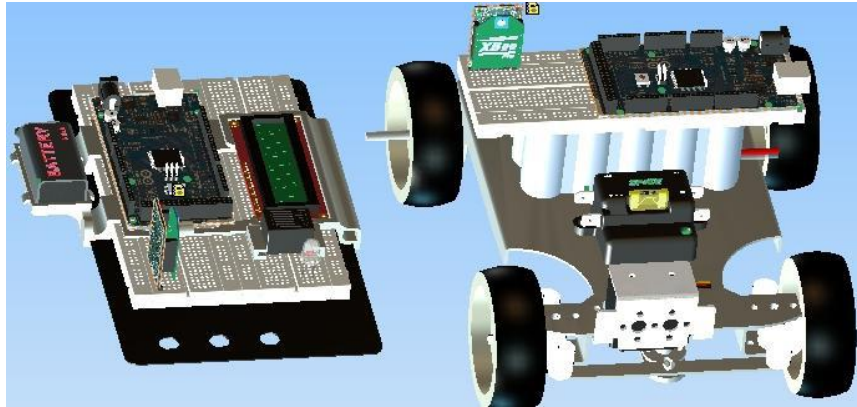


Figure 10: Computer Rendering of Remote Control Unit (left) and Chemical Detection Robot (Right)

Figure 11 and Figure 12 are the actual robot remote control unit and chemical detection robot (DCCDR), respectively, constructed by students. Note that Figure 12 has two prototypes of DCCDR.

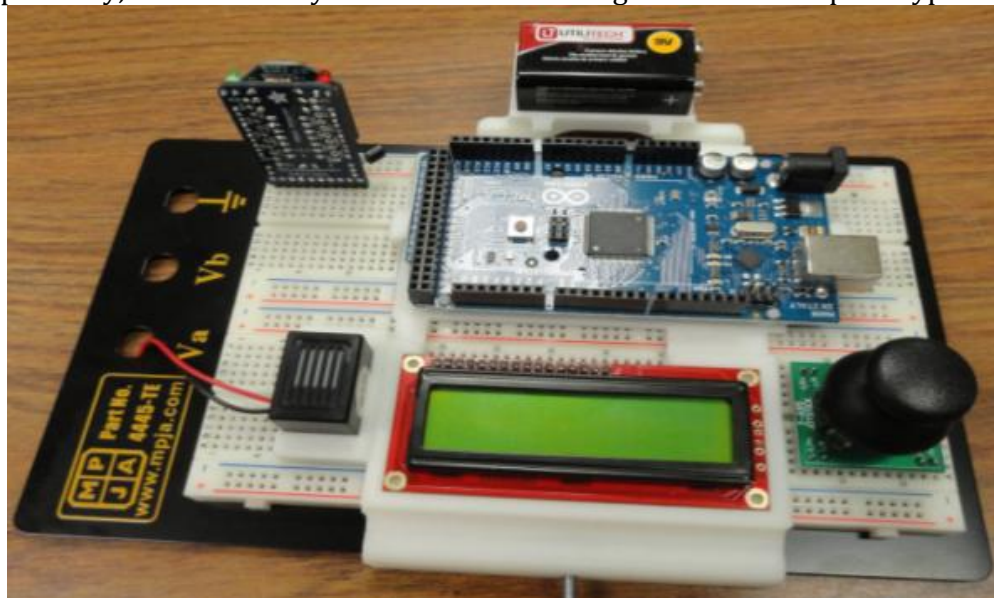
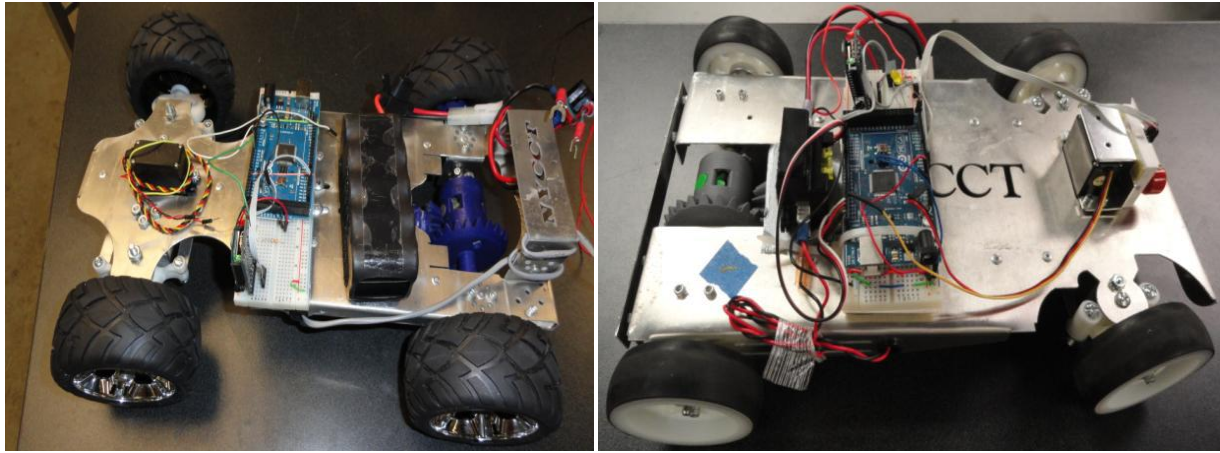


Figure 11: An Actual Remote Control Unit Prototype





Prototype One

Prototype Two

Figure 12: Prototypes of DCCDR

## Conclusion

Hands-on multi-disciplinary design project with concurrent engineering approach has given students an important tool and much needed precious experience for them to work in product design and development fields. It helps the students to form new perspectives in solving engineering problems and dealing with issues associated with product design and development: team work, time management, and balance between people skills and technical skills.

## References

- [1] Preston G. Smith, "Field Guide to Project Management – Chap 32: Concurrent Engineering Team", David I. Cleland, Editor, John Wiley & Son, 1998.
- [2] Andy S. Zhang, "Making Transition from 2-D Design to 3-D Design and Preparing to Bring the Product Lifecycle Management into the Classroom", *ASME 2005 International Design Engineering Technical Conference & Computer and Information in Engineering Conference*, IDETC/CIE 2005 85529, September 20-28, 2005, Long Beach, CA.
- [3] Ma, Y., Chen, G., Thimm, G., "Paradigm Shift: Unified and Associative Feature-based Concurrent Engineering and Collaborative Engineering", *Journal of Intelligent Manufacturing*, DOI 10.1007/s10845-008-0128-y
- [4] D. Xue and H. Yang, "A Concurrent Engineering-Oriented Design Database Representation Model", *Computer Aided Design* 36 (2004) 947-965, [www.elsevier.com/locate/cad](http://www.elsevier.com/locate/cad)
- [5] Kusiak, Andrew; *Concurrent Engineering: Automation, Tools and Techniques*
- [6] Quan, W. & Jianmin, H., *A Study on Collaborative Mechanism for Product Design in Distributed Concurrent Engineering* IEEE
- [7] "The standard waterfall model for systems development", NASA Webpage, November 14, 2008
- [8] Kock, N. and Nosek, J., "Expanding the Boundaries of E-Collaboration", *IEEE Transactions on Professional Communication*, Vol 48 No 1, March 2005.
- [9] Royce, Winston, "Managing the Development of Large Software Systems", *Proceedings of IEEE WESCON 26* (August 1970): 1-9.
- [10] Rosenblatt, A. and Watson, G. (1991). "Concurrent Engineering", *IEEE Spectrum*, July, pp 22-37.
- [11] Kathleen L. Kitto, "Integrating Concurrent Engineering into Undergraduate Design and Research Experiences", *Proceedings of the 1997 Conference on Frontiers in Education*, Pittsburgh, PA.
- [12] Abul K. M. Azad, Andrew Otieno and Radha Balamuralikrishna, "Interdisciplinary Student Projects Towards Simultaneous engineering: Learning and Issues Brought Forward", *ASEE, 2003 IL/IN Sectional Conference*, April 4-5, 2003 – Valparaiso University, Valparaiso, IN.
- [13] [http://en.wikipedia.org/wiki/Ackermann\\_steering\\_geometry](http://en.wikipedia.org/wiki/Ackermann_steering_geometry)
- [14] Crismond, David (2011) "Selected pedagogical approaches for integrating engineering design and scientific inquiry in project-based learning environments". In *Fostering Human Development through Engineering and Technology Education*, M. Barak and M. Hacker (Eds.). Netherlands: Sense Publishers.

## **Acknowledgement**

The work is partially funded by a grant from the National Science Foundation Advanced Technology Education Division. The award number is NSF ATE No 1003712. The authors appreciate greatly the support from the NSF. In addition, the authors also would like to thank all of the students who are involved in this project.

**Do Engineers Have Enough Computing Knowledge and Skills after Obtaining the Undergraduate Degree?**

Fani Zlatarova  
Elizabethtown College  
Elizabethtown, PA

Pavel Azalov  
Penn State Hazleton  
Hazleton, PA

# Do Engineers Have Enough Computing Knowledge and Skills after Obtaining the Undergraduate Degree?

Fani Zlatarova  
Elizabethtown College  
Elizabethtown, PA

Pavel Azalov  
Penn State Hazleton  
Hazleton, PA

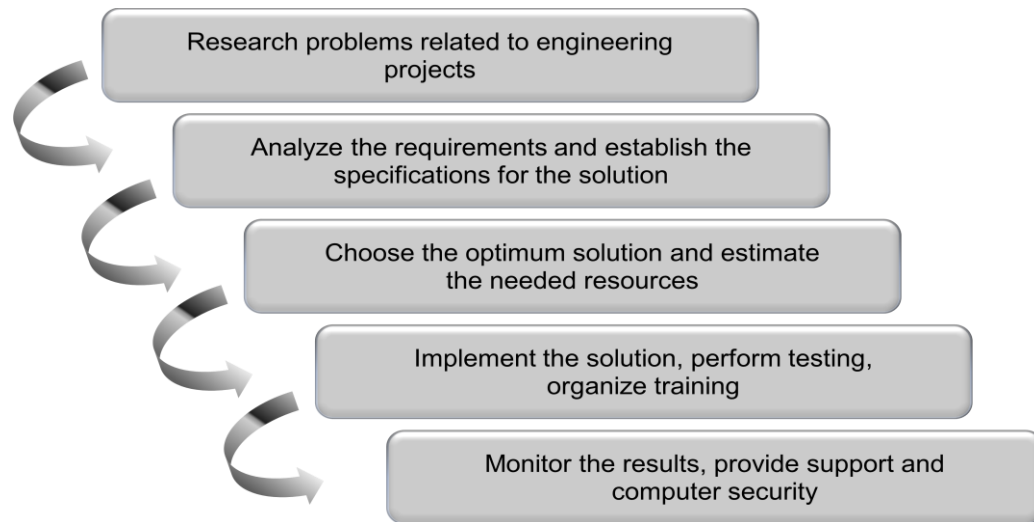
## Abstract

One of the main student learning outcomes for engineering students could be formulated as: “*Collect, analyze, and interpret data*”. Obviously, this statement implies possessing computing knowledge and skills. Current engineering students are future operational employees, supervisors and team leaders, middle managers and knowledge workers, and also top managers. Obtaining an appropriate background in Computing during the years of undergraduate studies is important for their successful career. The authors of this paper try to answer the question if the currently offered undergraduate computing courses for engineering students provide the needed preparation for taking advantage of Information Technology when developing a variety of projects in the everyday professional activity. After analyzing academic programs for engineering majors at different academic institutions, a recommendation is proposed to include the Systems Analysis and Design course belonging to the Software Engineering computing area. This course should be a required course or at least an elective course not only for students majoring in Computer Engineering but also in all Engineering curricula. The content of the course includes basic topics from the Computing theory and practice and provides students with a rich variety of Information Technology tools needed for the planning, analysis, design, implementation, operation, and support of engineering activities.

## 1. Introduction

Along with the traditional knowledge and skills, the engineering practice requires a great degree of creativity when developing miscellaneous projects. Finding an appropriate solution for the problems related to a project starts with the analysis and design of the respective problem and after that choosing the approach to solve it (Fig. 1). Presently, information technology (IT) is widely applied in all areas of the human life and especially in the engineering area because it offers significant advantages.

Software Engineering (SE) as one of the major computing sciences emerged from the traditional engineering practices by introducing IT to them. Today, it includes highly advanced methods that allow the development of software systems applied in different engineering-related cases. Not only the SE theoretical aspects have been researched, but SE-related standards have been established by the American National Standard Institute (ANSI) in collaboration with the International Standard Organization (ISO). In their everyday practice, engineers use a variety of software products as users and also as developers of specialized software systems. This is the reason SE represents an indivisible part of the engineering projects <sup>[5, 9]</sup>.



*Figure 1.* Steps in developing engineering projects

Researching Engineering curricula, which are different than Computer Engineering (CE) curricula, it would be interesting to understand if the computing courses included in them provide students with the needed computing knowledge and skills [6, 14].

## 2. Computing Courses in Engineering Curricula

Most academic institutions require only one undergraduate computing course for engineers and usually, this is an introductory course in programming, based on a programming language such as Java, C++, FORTRAN, Python, and others [1]. The programming course is very useful, because students would have the opportunity to learn introductory programming paradigms and develop routine in writing programs in a specific programming language. This is useful because engineers use existing software packages containing program libraries especially developed for solving engineering problems. They also participate in miscellaneous real projects at different levels. Basically, they need to provide the right input to existing programs and interpret the output obtained after the programs execution. There are colleges and universities offering few SE topics as a part of other courses. For example, it is possible to find similar courses having names such as Project Management, Basic Design, Introduction to Engineering Design, Engineering Design with CAD Systems, Engineering Design and Graphics, and others. However, thinking about the possible overall activities relevant to engineering projects, essential computing knowledge and skills are not part of the engineering curricula. With small exceptions, even Engineering curricula do not include the Systems Analysis and Design (SAD) course that represents the basic course from the SE area. This should be considered as absurd. The SAD course definitely should be one of the keystone courses offered to CE students. Mainly, the discussion from this paper focuses on including the SAD course in the curricula for engineering majors different than CE.

Students, who realize the importance of having a solid background in Computing take additional computing free elective courses or register for a Computer Science (CS) or Information Systems (ISs) minor or even major. This track is very challenging for students because engineering majors require a very high number of credits. The authors' opinion is that adding a SE course, e.g. SAD, as a required course or at least as an elective course for engineering students would be extremely useful. Students would be able to benefit from the topics discussed in this course, to develop experimental practice-oriented projects, to understand the core of the project management, and to practice with existing computer-aided software engineering (CASE) tools including computer-aided project management tools.

Having this course in the engineering curricula would better satisfy the recommendations established by leading organizations such as ASEE, IEEE, ABET, and others about engineering curricula and respective accreditations.

The phases of the project development from the engineering point of view and the related computing knowledge and skills accompanied by corresponding software products are described in the next section. This is intended to show why possessing strong background in SE would be important for engineering students.

### 3. The Role of the Systems Analysis and Design in Engineering Projects

Engineering activities rely heavily on implementing a variety of software systems which represent specialized ISs involving a high degree of integration, i.e. the output from an IS is accepted as the input by another IS. ISs combine IT, people, and data to support application requirements. In particular, Engineering represents a major application area. An IS could be graphically drawn as it is shown in Fig. 2.



Figure 2. Components of an information system

This simplified model suggests to a high extent why ISs are so important for engineers. In most of the cases, they use ISs to collect and store data, to use them for executing programs from specialized software packages, and to analyze, visualize, and interpret the obtained results. Sometimes, they also participate as developers of special-purpose ISs implemented when building up civil or industrial constructions, creating intelligent machines, designing power networks, researching biodigital problems, and many others <sup>[2, 3, 13]</sup>. Using the SSP (Subroutine Scientific Package), which is an IBM software product written in FORTRAN, could be considered as one of the first steps in the evolution of incorporating IT methods in the engineering research and practice. Currently, it is still used; however, the IT advances include much more. The innovative spirit that is characteristic for engineers puts them in a position to be among the first people adopting the most recent IT methods and approaches and implementing a variety of ISs, such as:

- enterprise computing systems,
- transaction processing systems,
- business support systems,
- knowledge management systems, and
- user productivity systems.

These systems are used by engineering professionals working at different levels of a company or organization (Fig. 3).



Figure 3. Typical levels of a company or organization

Developing ISs or using them requires engineering students to be able to know how to work with miscellaneous systems development computing tools such as:

- tools for project management,
- tools for systems modeling and design,
- tools for creating experimental models by applying agile methods, and
- computer-aided software engineering (CASE) tools.

Engineering students should also be familiar with the 4G (4<sup>th</sup> Generation) environment which includes data modeling languages (UML as a world standard), database languages (SQL as a world standard), powerful CASE tools, application generators, report generators, and others. At the moment of their graduation, engineering students should have experience from using different approaches for systems development, such as the traditional structured analysis, the object-oriented analysis, and the widely implemented contemporary agile methods <sup>[10]</sup>.

#### 4. The Variety of Basic Computing Knowledge and Skills for Engineering Students

As it was mentioned above, Engineering undergraduate curricula include, if any, introductory programming courses, such as Programming for Engineers with C++, Programming for Engineers with Java, or Programming for Engineers with FORTRAN <sup>[4, 8]</sup>. Actually, in most of the cases, students are required to select only one of them. This is far away from the understanding of a strong computing background for engineering students which is needed for the development of practice-oriented experimental engineering projects and for their future professional activity. These students should possess SE-oriented knowledge and skills relevant to the following phases characteristic for the development of an engineering project:

- project planning,
- project analysis,
- project design,
- project implementation, and
- project operation and support.

The corresponding project development computing tools relevant to each phase are discussed.

##### 4.1. Project Planning

Usually, this phase includes the formal request for the development of an engineering project by describing corresponding problems which should be solved. The preliminary investigation performed during this step consists of the analysis of the project's justification and feasibility. CASE tools such as Visible Analyst, Systems Architect, and others could be used for the preparation of the overall documentation, which is supposed to fulfill rigid standards imposed by ANSI and ISO. Using CASE tools affects the project management in a positive way and creates a better support for achieving the final goals of the project. The individual and group performance improves. The integrated meaningful information allows making right decisions. There exist stronger controls that lead to a higher quality of the project and reduce the cost of the project tasks.

The most widely used software products for automating the management of projects are Microsoft Office Project and Open Workbench. They allow the good understanding of project details and are very appropriate for the visualization of different project aspects. Both systems are applied for planning, scheduling, monitoring, and reporting activities performed during the planning phase. The project's success is determined by specific quality standards and depends on the decisions made about the project scope, budget limits, and time constraints. All of these factors could be modeled by using corresponding SE methods and tools to create a corresponding set of diagrams such as Gantt charts, PERT/CMP charts, network diagrams, and numerous spreadsheets.

Knowing how to create diagrams, which are specific for the planning phase, is important. For example, fishbone diagrams are considered to be an analysis tool that graphically highlights existing causes of problems. Pareto charts represent one of the most used tools for quality assessment. Using spreadsheet processing systems and even the graphical features of the recent text-processing systems empowers analysis and visualization aspects related to the planning process. Spreadsheet systems are also very appropriate for purposes of the risk management of the developed projects.

Having a clear vision and correct understanding about the organizational structure of the company or organization, which manages the project, is critical for the smooth flow of the entire project. Organizational charts should be developed and Microsoft Visio would be a helpful project development tool to draw them.

Using report generators belonging to the 4G environment would be useful for reporting the progress in the project development at the end of each project phase.

All above mentioned tools allow the correct analysis of the project usability and help to estimate the needed costs, time schedules, and possible benefits.

#### 4.2. Project Analysis

The analysis of engineering projects is similar to the systems analysis that represents the second step in the project/system development. This step includes the preliminary modeling and team-based development strategies, the fact-finding techniques, and preparing the corresponding documentation. Students should be taught to acquire skills that allow them to identify a problem, evaluate its main elements, and find an optimum solution. Conveying interpersonal communication skills to students is also important for the successful accomplishment of a project. SE provides information to students about the most used group-based techniques for developing team projects such as JAD (Joint Application Development), RAD (Rapid Application Development), and available modern agile methods, which reflect current trends for productive and creative collaboration between users and project developers.



There exists a rich set of modeling tools and techniques related to the analysis phase. The most important of them are mentioned below.

The functional decomposition diagrams (FDDs) are used to visualize function and/or processes. They implement the top-down approach in representing the main tasks of a project and the respective functionality. Another graphical analytical tool related to the structured analysis is provided by drawing data flow diagrams (DFDs). They show a closer look to the specific data exchange operations, represented through data flows, and describe corresponding process details at different levels. When documenting project aspects related to the object-oriented approach, UML, which is accepted to be a world standard, is very helpful for the development of a variety of useful diagrams. UML is not related to a specific programming language, and this offers flexibility in drawing diagrams such as:

- class diagrams,
- object diagrams,
- use case diagrams,
- state diagrams,
- sequence diagrams,
- activity diagrams,
- collaboration diagrams,
- component diagrams,
- deployment diagrams, and
- other features accompanying them (packages, notes, and stereotypes).

Engineers work with people representing different groups participating in the project development. They should possess the skills needed to conduct successful interviews, to write questionnaires and surveys, and to analyze and interpret obtained results. Working with documentation, which is electronically stored, is also part of the analysis phase. Being able to use contemporary communication tools and systems for distributed collaboration is highly needed.

The analysis phase also includes the data and processing modeling by using appropriate data models. This could be performed by drawing Entity-Relationship (ER) diagrams, containing the data and the relationships among them, or by drawing DFDs by choosing one of the existing sets: the Gane Set and the Sarson and Yourdon Set. The good understanding of the concepts related to DFDs, such as balancing, leveling, data flows, and processes would lead to the production of correct and meaningful diagrams that reflect clearly the project essentials.

Using data dictionaries, also called catalogs, containing the description of all the data and everything related to them allows a high data independence at logical and physical levels of the data representation and the data processing. Knowing how to describe existing processing relevant to a project is also needed. Flow-charts can graphically show the programming constructs inside the modular design of a project. Other commonly used tools for process description are:

- Structured English, similar to a Pseudocode used to explain algorithms for solving problems by using a computer;
- Decision Tables, showing the logical structure and displaying the possible combinations between outcomes and existing conditions;
- Decision Trees, which graphically represent all the elements contained in a decision table.

The object-oriented modeling of data and related properties and operations (methods) is possible if knowing the corresponding object-oriented concepts, tools, techniques, and object-oriented programming languages (for example Java and C++) which are considered in most of the introductory programming courses offered to engineering students. Understanding terms and notions relevant to the object-oriented analysis such as object, class of objects, inheritance, encapsulation, polymorphism, associativity, and others could be used when writing program code which solves specific project-related algorithmic problems. As it was mentioned above, UML is the main modeling tool in the object-oriented system analysis. Engineers should be able to use the most recent strategies for project development. Possessing knowledge about the traditional development strategies is a requirement. However, the Web-based strategies start to overtake because of the globalization of the world's economies. SE will provide engineering students with knowledge and skills to perform cost-benefit analysis and to choose the right software packages and hardware products which could empower tremendously the development of their projects. Students should be familiar with the dynamic aspects of IT and should have the ability to learn new computing technologies, such as the cloud computing, the upcoming Web 3.0, and everything which makes the virtual reality become an everyday practice <sup>[7, 12]</sup>.

Performing financial analysis related to projects by using appropriate software products is required when analyzing the cost and benefits of a project. Orientation about existing specialized software and needed corresponding hardware is helpful. All the guidelines related to the project development and provided by SE will assure a solid basis for the successful termination of the project.

#### 4.3. Project Design

After accomplishing the planning and analysis of a project, the next phase, the project design, could start. The output of the results from the project should be determined at this moment. To a high extent, the success of the project is based on the user-friendly human-computer interaction, i.e. on the language tools and interface environment used in an IS which is implemented in an engineering project. SE provides specific principles which should be known and kept. When engineers use specialized software packages, an appropriate output should be produced to help them obtain valuable multimedia results. Knowing how to create miscellaneous reports, such as detail reports, exception reports, or summary reports would be extremely appreciated for the decision making process. Learning how to work with pivot tables in spreadsheet processing systems or in database management systems (DBMSs) would be also helpful. SE also teaches how to create well-structured and well-edited documents and Web story boards which are technically sound.

One of the most frequently asked questions by employers during internship and job interviews is if the applicant can use the relational language SQL used in the majority of DBMSs today because ISs are used everywhere in the human life. They are based on databases and DBMSs. Respective basic knowledge and skills about them should be acquired by engineering students. They should understand topics from the area of the data design, data models, relational and object-oriented DBMSs, normalization, query processing, Internet DBMSs, and others.

All projects involve collection of data and their storage in appropriate media. Organizing them in a database is already a tradition. Developing database diagrams in different DBMS environments would clarify the data modeling and the establishment of correct relationship corresponding to a given data model. Applying integrity rules, such as entity integrity and referential integrity, is directly related to the development of specific databases. Students should know the basic maintenance operations on data along with the retrieval operation. This knowledge is required for always having well-organized and consistent data in a database. Methods of the Artificial Intelligence are used when creating knowledge databases

used for the development of data warehouses by applying data mining software which looks for meaningful patterns and desirable relationships among data.

One of the most important requirements today when processing data in different computer and networking environments is related to the data, computer, and network security issues. Possessing basic knowledge about network systems software and hardware is critical for the safety of the electronic communication used in the majority of the developed projects in a global environment.

#### 4.4. Project Implementation

After the first three phases, the project finally should be implemented, tested, and the people, who will use the project outcomes, should be trained. SE describes the implementation tasks which are accompanied by corresponding quantitative and qualitative metrics. During this phase, structure charts are developed to visualize the modularity of the project tasks and to describe their functionality by determining the corresponding primitive functions.

Engineering students would benefit to understand the possible conversion steps in the project implementation such as:

- direct implementation,
- parallel operation,
- pilot operation, and
- phased operation.

They also should be able to perform post-implementation evaluation by using specific CASE tools and appropriate application software systems.

#### 4.5. Operating and Support Activities

The support activities for managing the results obtained from a project are important for the smooth operation. They include different types of maintenance tasks such as

- corrective maintenance,
- adaptive maintenance,
- perfective maintenance, and
- preventive maintenance.

Teaching SE to engineering students creates the opportunity for them to adopt the principles of ethical conduct and moral behavior as users and developers of software products <sup>[11]</sup>. Students should be able to show integrity in their individual decisions as engineering professionals. These decisions could affect in a positive way their social and working environment.

### 5. Conclusions

By describing the major SE topics and in particular the SAD topics, it would be possible to understand how important they are for students majoring in different engineering fields. Some of these topics are considered briefly in introductory programming courses which are a part of engineering curricula. However in the majority of the cases, they are not included at all. A well-designed SE course would be a good addition to every engineering curriculum. The content of this course would enable the development of practice-oriented individual and team projects <sup>[15]</sup> which provide students with a routine in using a rich

variety of appropriate software products and corresponding computing environments and integrated platforms.

The topics included in a SAD course which should be offered to engineering students during their undergraduate studies should represent an indispensable part of the engineering curriculum. Possessing a strong background in Computing would allow them a flying start in their professional career along with solid knowledge and skills in pursuing graduate degrees.

Foremost, engineers are people of action. Engineering students deserve to be prepared for the challenges of their profession. They should be able to implement their creativity and make their dreams come true by also relying on the computing power.

## References

- [1] Bäcker, A. *Computational Physics Education with Python*. IEEE Computer Society, Computing in Science and Engineering, May 2007, pp. 30-33.
- [2] Glotzer, S. C., B. Panoff & S. Lathrop. *Challenges and Opportunities in Preparing Students for Petascale Computational Science and Engineering*. [IEEE Computer Society, Computing in Science and Engineering, September 2009, pp. 22-27.](#)
- [3] Hasna, A.M. *E-competence in chemical engineering learning and teaching*. 2nd International Conference on Education Technology and Computer (ICETC), Volume 4, 2010, pp. V4-330 - V4-336.
- [4] Jermann, W. H., *Using computers in an engineering curriculum. Where are we? Where are we going?* [Frontiers in Education, FIE 26th Annual Conference](#). Proceedings volume, 1996, pp. 1402-1404.
- [5] Kelly, D, S. Smith & N. Meng. *Software Engineering for Scientists*. IEEE Computer Society, Computing in Science and Engineering, September 2011, pp. 7-11.
- [6] Kral, J. & M. Zemlicka. *Engineering Education - A Great Challenge to Software Engineering*. ICIS 08. Seventh IEEE/ACIS International Conference on Computer and Information Science, 2008, pp. 488-495.
- [7] Lutz, R. *Software Engineering for Space Exploration*. IEEE, Computer, September 2011, pp. 98-101.
- [8] MacBride, G., E. L. Hayward, G. Hayward, E. Spencer, E. Ekevall, J. Magill, A. C. Bryce & B. Stimpson. *Engineering the Future: Embedding Engineering Permanently Across the School–University Interface*. IEEE Transactions on Education, Volume 53, Issue 1, 2010, pp. 120 – 127.
- [9] Meyer, B. *Software Engineering in the Academy*. IEEE, Computer, May 2001, pp. 28-35.
- [10] Qumer, A. & B. Henderson. *An evaluation of the degree of agility in six agile methods and its applicability for method engineering*. Information and Software Technology, Volume 50, Issue 4, March 2008, pp. 280-295.
- [11] Rashid, A. J. Weckert & R. Lucas. *Software Engineering Ethics in a Digital World*. IEEE, Computer, May 2009, pp. 34-41.
- [12] Rhodes, D. H. *Systems engineering: an essential engineering discipline for the 21st Century*. ICSE, Proceedings of the 24rd International Conference on Software Engineering, 2002.
- [13] Sendlinger, S. C., D. J. DeCoste, T. H. Dunning, D. A. Dummitt, E. Jakobsson, D. R. Mattson & E. N. Wiziecki. *Transforming Chemistry Education through Computational Science*. IEEE Computer Society, Computing in Science and Engineering, September 2008, pp. 34-39.
- [14] Welch, H.L. *Teaching a service course in software engineering*. IEEE, 37th Annual Frontiers In Education Conference - Global Engineering: Knowledge Without Borders, Opportunities Without Passports, 2007, pp. F4B-6 - F4B-11.

- [15] Zlatarova, F. *Diversity in the Development of Computing Projects*. ASEE, Spring 2007 Middle Atlantic Conference Proceedings, 2007, <http://www.asee.org/papers-and-publications/papers/section-proceedings/middle-atlantic/spring-2007>.

**3-D Pore-Scale Resolved Model for Transport in a Vanadium Redox Flow Battery using X-ray Tomography and the Lattice Boltzmann Method**

Gang Qiu,  
Department of Mechanical Engineering and Mechanics,  
Drexel University,  
Philadelphia, PA 19104

Abhijit S. Joshi  
Department of Mechanical Engineering and Mechanics,  
Drexel University,  
Philadelphia, PA 19104

Christopher R. Dennison  
Department of Mechanical Engineering and Mechanics,  
Drexel University,  
Philadelphia, PA 19104

E. C. Kumbur  
Department of Mechanical Engineering and Mechanics,  
Drexel University,  
Philadelphia, PA 19104

Ying Sun  
Department of Mechanical Engineering and Mechanics,  
Drexel University,  
Philadelphia, PA 19104

### **3-D Pore-Scale Resolved Model for Transport in a Vanadium Redox Flow Battery using X-ray Tomography and the Lattice Boltzmann Method**

*Gang Qiu, Abhijit S. Joshi, Christopher R. Dennison, E. C. Kumbur, Ying Sun*

Department of Mechanical Engineering and Mechanics, Drexel University, Philadelphia, PA 19104

The Vanadium Redox Battery (VRB) promises to be an attractive option for storing electrical energy from renewable energy sources and delivering the stored energy to the grid whenever it is required. In this work, a novel methodology is proposed for modeling the transport mechanisms in the VRB including the flow of electrolyte in the pore space of the porous electrode, chemical species transport through the electrolyte, electrochemical reactions at active sites and transport of charge through the solid and electrolyte phases. The detailed geometry of the electrode is obtained using X-ray computed tomography (XCT) and this geometry is first calibrated against experimentally determined values to calculate the porosity. The XCT geometry is further characterized to calculate the pore-size distribution, connectivity and the active surface area for electrochemical reactions. The processed XCT data is then used as geometry input for modeling transport processes in the VRB at the pore-scale, that is at the level where individual carbon fibers and electrolyte can be clearly resolved. The flow of electrolyte through the pore space is modelled using the lattice Boltzmann method (LBM). An electrochemical model using the Butler-Volmer equations is used to provide local current density and species mole flux at the surface of the carbon fibers and to provide the necessary coupling to the local concentration of these species present in the pore space. Having obtained a solution to the flow field using the LBM, a finite volume method is used to solve the governing equations for species and charge transport and predict the performance of the VRB under various conditions. The model developed is used to better understand the impact of assembly-induced compression on the micro-structural properties and performance of a vanadium redox battery. Results are obtained for the battery voltage variation under galvanostatic charge and discharge conditions. The model provides a useful tool that can be used to clarify the structure-performance relationship in the VRB and to optimize the flow of electrolyte inside the battery. This approach can also be useful for developing a fundamental understanding of transport processes in other electrochemical energy conversion devices such as solid oxide fuel cells, proton exchange membrane fuel cells and lithium-ion batteries.

## **Blended Learning with Nuclear Reactors**

Artur Ljamin<sup>1</sup>, Jeffrey Gorn<sup>1</sup>, Timothy Golden<sup>1</sup>, Ezekiel J. Blain <sup>2</sup>, Bryndol Sones<sup>1</sup>,  
Timothy H. Trumbull<sup>2</sup>, Brian Moretti<sup>1</sup>, Don Gillich<sup>1</sup>

1 Department of Physics and Nuclear Engineering,  
United States Military Academy,  
West Point, NY 10996

2 Department of Mechanical, Aerospace, and Nuclear Engineering,  
Rensselaer Polytechnic Institute,  
Troy, NY 12180



# Blended Learning with Nuclear Reactors

Artur Liamin<sup>1</sup>, Jeffrey Gorn<sup>1</sup>, Timothy Golden<sup>1</sup>, Ezekiel J. Blain<sup>2</sup>, Bryndol Sones<sup>1</sup>,  
Timothy H. Trumbull<sup>2</sup>, Brian Moretti<sup>1</sup>, Don Gillich<sup>1</sup>

<sup>1</sup>*Department of Physics and Nuclear Engineering, United States Military Academy, West Point, NY 10996*  
<sup>2</sup>*Department of Mechanical, Aerospace, and Nuclear Engineering, Rensselaer Polytechnic Institute, Troy, NY 12180*

## Abstract

Cadets majoring in Nuclear Engineering (NE) at the United States Military Academy (USMA) at West Point have the opportunity to participate in a blended learning laboratory experience using the reactor critical facility (RCF) at Rensselaer Polytechnic Institute (RPI). RPI, through a grant from the Nuclear Regulatory Commission, developed a series of laboratory modules and associated lectures using their RCF. As a pilot program, the cadets at West Point conducted a blended learning laboratory exercise using a series of online videos which included both lecture and the conduct of a laboratory. Prior to conducting the blended learning laboratory, cadets mapped the neutron flux in a sub-critical assembly at West Point. A survey conducted of the cadets at the conclusion of the blended learning laboratory exercise indicated that the previous work with the sub-critical assembly at USMA was most helpful in understanding the material presented by the module laboratory developed by RPI. This paper outlines the laboratory program and presents lessons learned from the conduct of this series of exercises from the student's perspective.

## Introduction

During their sophomore year, cadets can choose to major in NE at West Point. Their initial NE class concentrates on learning core concepts and does not include any laboratory work. In the second semester of the NE major, cadets conduct laboratory exercises with plutonium-beryllium (PuBe) neutron sources in a sub-critical facility as part of a course dedicated to nuclear reactor design. This lab exposes students to working with nuclear material and to detecting and plotting the neutron flux.

Conducting laboratory exercises with a sub-critical assembly helps the students reinforce the knowledge learned in the classroom environment and prepares them to take the next step in the educational process of the NE program. Because West Point does not have a critical reactor, NE Faculty at USMA teamed with RPI Faculty to offer students an opportunity to gain experience with the RCF. This experience was delivered using multiple videos that first present lectures given by RPI instructors about the concept of the lab and then the conduct of the laboratory itself.

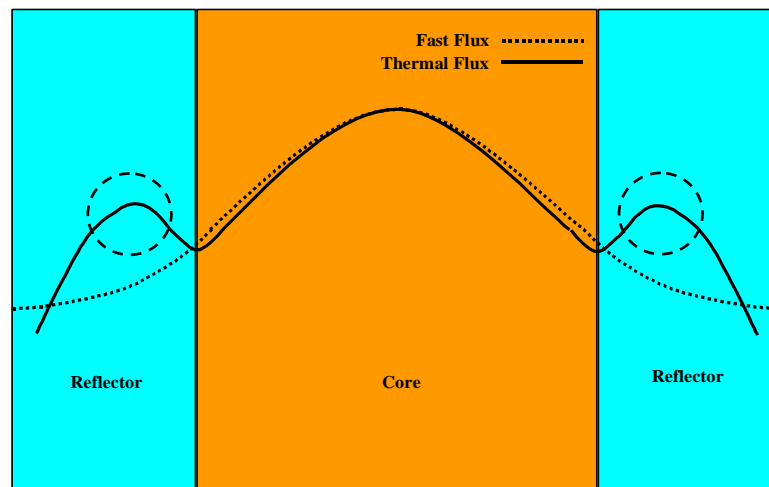
*Disclaimer: The views expressed herein are those of the author and do not reflect the position of the United States Military Academy, the Department of the Army, or the Department of Defense.*

This blended learning opportunity enables cadets to broaden the skills and knowledge gained in the classroom to the laboratory environment. It is essential for the cadets to work with the West Point sub-critical assembly prior to the conduct of this blended learning experience, as it prepares them to better understand the experiment conducted with the RPI critical reactor.

## West Point Nuclear Reactor Design Laboratory Program

Nuclear engineers must understand the neutron flux distribution in a reactor. Therefore, the laboratory exercises conducted during the nuclear reactor design course at West Point revolved around measuring and calculating the flux at different positions in a given geometry. The neutron flux is the number of neutrons per unit area per unit time. Because the neutron density is higher within proximity to a fission source, it follows that the flux will be the highest near the center of the source and decrease with distance from the source.

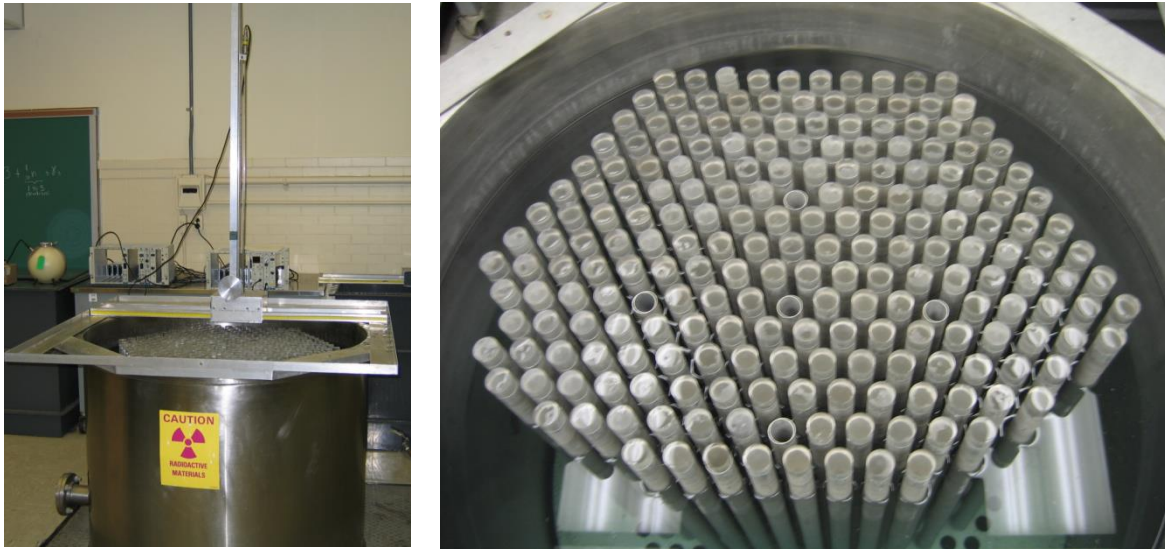
Later in the course, cadets derive the equations needed to solve for the neutron flux at any point away from the source, given the geometry. Students also learn that for a cylindrical reactor the flux in the radial direction away from the center follows a Bessel-function shape, while the neutron flux along the length of the fuel rod in the axial direction varies with the shape of a cosine function. Reactors with moderating reflectors will also have a small peak in the thermal moderation of fast neutrons that leak from the core and are moderated in the reflector region. This theoretical distribution of neutrons within the reactor can be observed in Figure 1 and is verified experimentally by taking measurements of neutron counts at various positions within the reactor core.



**Figure 1:** Fast and thermal radial flux profiles for a cylindrical, reflected, homogeneous reactor.<sup>1</sup>

Following these conceptual lessons, the cadets conduct a laboratory exercise utilizing a plastic, rectangular container filled with water, referred to as a sigma-pile. In the sigma-pile exercise, cadets place a single one curie PuBe neutron source at the bottom, center of the sigma-pile. A BF<sub>3</sub> detector system is used to measure the number of neutrons at various positions from this source. The BF<sub>3</sub> detector is positioned at known radial and axial distances from the source and neutron counts at each position are measured and plotted. This laboratory serves as an introduction to the experimental process with the goal of measuring the diffusion length of thermal neutrons in water. Cadets also gain hands-on experience with the detector system which is used in the sub-critical assembly laboratory.

Cadet conceptual knowledge of the neutron flux is further expanded through the use of the sub-critical assembly. The sub-critical assembly, fueled with natural uranium and moderated with distilled water, cannot sustain a nuclear chain reaction without an external neutron source. In this laboratory exercise, five one curie PuBe neutron sources were placed in the sub-critical assembly, initiating fission of the natural uranium, and a steady-state neutron flux was established. The sub-critical assembly is shown in Figure 2.



**Figure 2:** Images of the sub-critical assembly setup with the  $\text{BF}_3$  detector system (left) and the sub-critical assembly top view (right). The fuel tubes are arranged in a hexagonal shape.

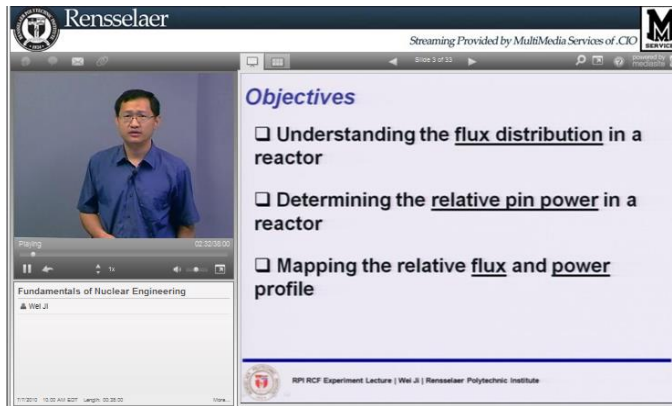
The goals of this laboratory exercise were to measure and map the axial and radial thermal neutron flux distribution of the sub-critical facility and then to ultimately calculate its effective neutron multiplication factor.

### **Video Experience: Critical Reactor Lab**

The final lab of this nuclear reactor design course series was conducted using an online module provided by RPI through a grant from the Nuclear Regulatory Commission. West Point cadets were provided an access user ID and password to RPI's Learning Management System (RPI LMS) by the RPI laboratory instructor. Cadets were given a week to watch the video of the laboratory experiment conducted at the RCF by RPI students and then to write up the results in a report.

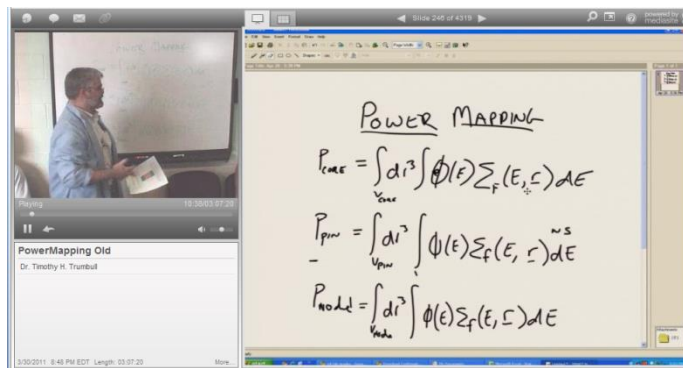
The module chosen for use at West Point was a laboratory experiment to determine the RCF power distribution. This power mapping is related to the West Point laboratory exercises because the power distribution within a reactor is correlated to the thermal neutron flux distribution. If there are more thermal neutrons available at a position in the reactor, there will be higher probability of fission and hence, higher power at that position. Therefore, it is expected that the power distribution will have a similar plotted shape as the thermal neutron flux depicted in Figure 1.

To enhance viewing of the experiment, the instructor provided additional videos that present an overview of the concepts behind the module. The first was a video lecture by Dr. Wei Ji at RPI which included the underlying theory behind radial and axial power mapping. Figure 3 is a screen capture of Dr. Ji's lecture.

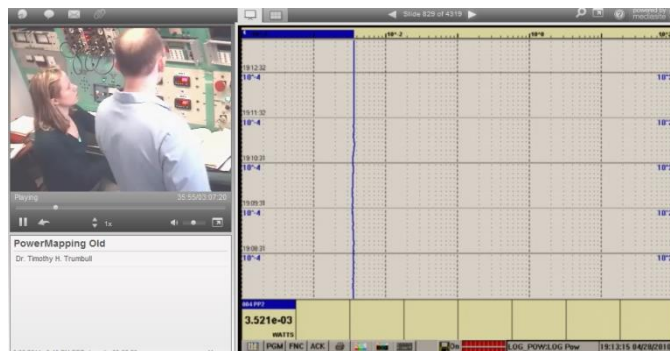


**Figure 3:** Screen capture of the video module provided by RPI. Dr. Ji reviews the theory behind flux distribution and power in a critical reactor.

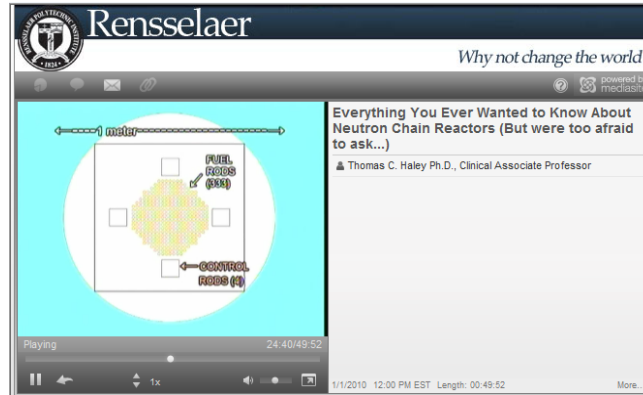
The second video was three hours long and taped at the RCF which included an introductory lecture by Dr. Timothy H. Trumbull about power mapping (approximately 25 minutes) and then the conduct of the lab itself. Figure 4 is a screen capture of the power mapping lecture portion of the video. Figure 5 is a screen capture of the conduct of the lab itself.



**Figure 4:** Screen capture of the video module provided by RPI. Dr. Trumbull reviews the theory behind power mapping of a critical reactor in this three hour video.



Viewing of a third video was optional. It was a video giving an introduction to fission and other related RCF processes which provided an overview of some reactor analysis and design considerations. Figure 6 provides a screen capture of this video in which Dr. Thomas C. Haley presents an overview of the fission process and the RCF.



**Figure 6:** Screen capture of the “Everything You Ever Wanted to Know About Neutron Chain Reactions (But were too afraid to ask...)” introduction video to the RCF.

The video of the laboratory exercise being conducted was also viewed online. Although the cadets at West Point were not able to directly participate in the experiment, the video followed every step of the RPI students’ experimentation. Instead of  $\text{BF}_3$  detectors, students at RPI used a collimated shield and a sodium iodide detector gamma spectroscopy system to find the number of delayed fission product gamma rays at locations in the core. Because the gamma-ray intensity is proportional to the concentration of fission products, the power distribution within the reactor can be determined from this data.

After watching the two required videos, the West Point cadets were then given RPI’s laboratory manual for the experiment, as well the data from the lab that would otherwise have been available to them if they had conducted the measurements taken in the video themselves. Based on this information, cadets then analyzed the data, and provided analyses similar to those exercised while conducting the sigma-pile and sub-critical assembly experiments at West Point.

### Assessment

The desired outcome of the blended learning program was to enrich the West Point curriculum by offering cadets an opportunity they would otherwise not be afforded because USMA does not have a critical reactor facility. To assess the effectiveness of this pilot program, in addition to grading the laboratory reports, West Point NE faculty sought feedback from the cadets involved. This feedback was collected via a course survey and results were measured using a constructed proxy scale of 0 to 5. The scale numbers represent the following responses:

0. I didn’t watch the video.
1. Not at all.
2. Slight extent.
3. Moderate extent.
4. Great extent.
5. Very great extent.

The questions specifically inquired about the effect each video had on the learning process. The survey also asked the cadets if they found prior laboratory exercises conducted at West Point helpful. Because RPI's Laboratory Manual provided an explanation of the theory for the experiment, it was also included in the survey. The overall effectiveness of the blended learning laboratory program was reflected in an average score of 3.56 based on the results from 18 cadet participants. The breakdown for each rated material is reflected in Table 1.

It was important to note that not all cadets watched all the videos. Because some cadets had no basis to judge the efficacy a given video, it was more accurate to only account for those cadets who actually watched the video. Therefore, dividing the sum of the scores by only those cadets that watched the video showed a significant increase of the rating for each video. These results are depicted in the adjusted column of Table 1.

**Table 1:** Collected data from surveys. The raw data column depicts all the student responses. The adjusted column shows the rating of the video by only those cadets who actually watched each video.

| Material                                     | Raw data | Adjusted |
|----------------------------------------------|----------|----------|
| Video lesson by Dr. Wei Ji                   | 2.06     | 2.64     |
| Video on power mapping by Dr. Tim Trumbull   | 2.44     | 3.14     |
| Video of the actual experiment               | 1.61     | 2.41     |
| Video on fission by Dr. Tom Haley (optional) | 1.11     | 4.00     |
| RPI's Lab Manual                             | 3.44     | N/A      |
| Prior Laboratories at West Point             | 3.78     | N/A      |

The required videos had an average of 2.73 on the 5 point scale as rated by the cadets. The optional video on the basic principles of fission and an overview of the conduct of RCF lab by Dr. Haley was viewed by only 20 percent of the class. However, those students that did view this video, found it more helpful when compared with the other videos with an average of 4.00 out of the 5 point scale. The video of the actual experiment was rated the lowest likely because the conduct of the laboratory involved repetitive tasks with relatively long gaps between taking data. Additionally, the laboratory video was 2 and half hours long.

The results in Table 1 also show that, besides the optional video, prior laboratories conducted at West Point provided cadets with the most effective and useful experiences to help them complete the RPI laboratory. This result indicates that it may be better to have a “crawl, walk, run” approach to education in a blended learning environment. In the crawl phase, concepts can be introduced in class and preliminary laboratories can be conducted to introduce students to the equipment and experimental methods. During the walk stage, similar laboratories can be conducted with equipment available locally (i.e. the sub-critical assembly). Finally, during the run stage, students are able to synthesize their experiences from hands-on laboratories and apply that knowledge in a virtual environment.

There are a few suggestions for improvement to the blended learning laboratory program. One obvious improvement is that the video of the basic principles of fission and the RCF overview should be made mandatory for the cadets at West Point. Those cadets that watched the video, thought it very useful. The primary sustain for this program is the progression of the laboratories, starting with an analysis of neutrons diffusing in water, the sub-critical assembly and ending with the RCF. The increasing

complexity of the laboratories and the advancing depth of nuclear engineering concepts tailor the laboratory experience to cadets beginning with little understanding of the behavior of nuclear reactors to successfully equip them with more advanced knowledge and a fuller understanding of nuclear reactors.

## **Conclusions**

The collaborative effort between USMA and RPI proved to be successful. RPI's pilot program to create and export blended learning laboratory modules proved to be very beneficial to the cadets' learning and gave them experience that they would not have had otherwise. NE Faculty at West Point also gained valuable insights into the educational benefits of blended learning laboratories and learning in a virtual environment.

The survey results offer a valuable assessment of the nuclear reactor design laboratory exercises at West Point, and the blended learning exercise created by RPI. Clearly the laboratory exercises have been an effective tool for enriching the NE curriculum and contribute to a comprehensive understanding of key concepts and materials the course is designed to target. The blended learning laboratory reinforced cadet learning while giving them exposure to a critical reactor facility.

## **Reference**

1 T. H. Trumbull, "MANE-4440: Critical Reactor Laboratory," *A Manual of Experiments* (2008). 2.

**SECTION 7 - STUDENTS SECTION**



## **Acoustic Noise Synthesis For Muffler System Design And Simulation**

B. Rajavel

Noise and Vibration Control Laboratory,  
Department of Mechanical Engineering,  
Stevens Institute of Technology,  
Hoboken NJ-07030

M.G.Prasad

Noise and Vibration Control Laboratory,  
Department of Mechanical Engineering,  
Stevens Institute of Technology,  
Hoboken NJ-07030

# Acoustic Noise Synthesis for muffler system design and simulation

## Abstract:

Mufflers are typically used to reduce the automotive exhaust noise, which is one of the major contributors of noise pollution in an urban environment. In addition, mufflers are also used to reduce the noise generated in HVAC ducts and cabin conditioning noise in aircraft. This paper describes an Acoustic Noise Synthesis (ANS) technique used for design of a virtual muffler based on Insertion Loss (IL) approach and additionally provides an audio simulation of its sound output. In this ANS technique, first the transfer function of the given muffler system is evaluated using the four pole parameters, source strength, source acoustic and termination acoustic impedances. Then the impulse response of the predicted transfer function is convolved with source signal to obtain the acoustic noise output of the muffler system in frequency domain. In order to verify this technique, the simulated output sound from virtual muffler is compared with experimentally measured sound for two types of systems namely a straight pipe and a simple expansion chamber. The results shows that the proposed ANS procedure gives reliable simulation of the acoustical noise generated by the real muffler system. The proposed ANS procedure can be applied to any complex system. The ANS procedure will have applications in studies related to virtual muffler design, sound quality and noise control studies of muffler system before actual fabrication of the muffler system.

## 1. INTRODUCTION

Acoustical studies of duct systems are important in many systems such as automotive exhaust systems, HVAC equipments, etc. Some of the performance descriptions predominately employed by acoustical engineers are insertion loss, transmission loss and noise rating. For example, in the case of automotive exhaust muffler system, measurement of insertion loss is preferred to evaluate the acoustic performance of mufflers. With the use of insertion loss approach, one can avoid the complicated method of measuring the sound pressure inside the hot exhaust gas system by simply measuring the sound pressure

in free space at the same distance from the tailpipe without and with the muffler in place. Though the insertion loss is a preferable measurement technique for both manufacturers and customers, the prediction of insertion loss is complicated because it requires the system source impedance, radiated acoustic impedance and four pole parameters<sup>1,2</sup>. The transmission loss approach which is also a popular method among muffler manufactures which is based on the fraction of acoustic power a muffler transmits. The transmission loss is more difficult to measure than insertion loss because the power incident on the muffler must be determined from complicated measurements made in the exhaust gases upstream of the muffler<sup>1,2</sup>. The transmission loss is easier to predict than insertion loss because it requires only the four pole parameters of the duct system and it is independent of source and radiated acoustic impedance. However, a knowledge of the muffler transmission loss is not very useful to the manufacturer as well as customers since it does not enable a comparison to be made between the presence of with and without the muffler and performance of different mufflers in an exhaust system as does the insertion loss.

If an accurate theoretical prediction scheme for muffler performance can be formulated, then probably an even more useful quantity to predict than insertion loss is the sound pressure radiated in free space from the tailpipe. Prasad and Crocker<sup>3</sup> formulated a procedure to measure the sound pressure level using the system four pole parameters and system boundary conditions.

Though this approach gives more information for acoustic studies of duct systems, it is only useful after the system is actually manufactured. Hence, if we are able to virtually simulate the acoustical noise based on the design so that both noise control and sound quality assessment can be done before the fabrication of the system. The present paper explains the procedure to simulate the sound pressure level virtually before the system is actually fabricated and it employs the transfer function approach and also considers the time dependency.

A preliminary study on simulation of acoustical noise has been reported by Kitu kumar et al<sup>4,5</sup>. The work presented here is termed as Acoustical Noise Synthesis (ANS) which is an audio simulation of

acoustical noise of a duct system consisting source, duct element and termination. These three components can be acoustically characterized by source acoustic impedance, source strength, four pole parameters of the duct elements and termination acoustic impedance. The transfer function of the entire system is evaluated based on the system characteristics. Then the impulse response of the system is obtained from the transfer function. The simulated sound response is obtained by convolving a white noise (or source signal) with the impulse response of the system. The spectra of the simulated noise and the measured noise are compared to verify the methodology. Two types of duct systems are used in this work to verify the ANS method.

## 2. BACKGROUND

The evaluation of the transfer function of the duct system is an important step in the ANS procedure. The transfer function in this case corresponds to a source-duct -termination model and can be approximated by using the four-pole parameters ( $\tilde{A}, \tilde{B}, \tilde{C}, \tilde{D}$ ) of each component of the system<sup>6</sup>. Figure 1 shows the physical and electrical analogs of the duct system model used for this work. Taking the four pole parameters of each component and combining them, in conjunction with the electrical analog, we get the following system matrix:

$$\begin{bmatrix} \tilde{P}_s \\ \tilde{V}_s \end{bmatrix} = \begin{bmatrix} 1 & 0 \\ 1/\tilde{Z}_s & 1 \end{bmatrix} \begin{bmatrix} \tilde{A} & \tilde{B} \\ \tilde{C} & \tilde{D} \end{bmatrix} \begin{bmatrix} 1 & \tilde{Z}_r \\ 0 & 1 \end{bmatrix} \begin{bmatrix} \tilde{P}_o \\ \tilde{V}_o \end{bmatrix} \quad \text{----- (1)}$$

Where,  $\tilde{P}_s, \tilde{V}_s$  are source sound pressure and source strength respectively,  $\tilde{Z}_s$  is the source acoustic impedance,  $\tilde{A}, \tilde{B}, \tilde{C}, \tilde{D}$  are four pole parameters of the duct systems,  $\tilde{Z}_r$  is the termination acoustic impedance and  $\tilde{P}_o, \tilde{V}_o$  are the sound pressure and volume flow rate ( $\text{m}^3/\text{s}$ ) at the tip of the open end termination. The volume velocity ratio  $\left| \frac{\tilde{V}_s}{\tilde{V}_o} \right|$  is given by the second row-second column element of the overall product in equation (1). Taking the inverse of the volume velocity ratio gives us the transfer function of the duct system.

$$|\tilde{H}(\omega)| = \frac{|\tilde{V}_o|}{|\tilde{V}_s|} = \left| \frac{1}{(\tilde{A}\tilde{Z}_r + \tilde{B})(1/\tilde{Z}_s) + (\tilde{C}\tilde{Z}_r + \tilde{D})} \right| \quad \text{----- (2)}$$

The transfer function in equation (2) can be applied to design a duct system provided the system parameters namely the four pole parameters, source acoustic impedance and termination acoustic impedance are known.

### 3. SIMULATION OF DUCT SYSTEM USING ANS

In this work, a straight pipe and a simple expansion chamber duct system are used for simulation. Before beginning the ANS simulation, it is required to measure the source strength ( $\tilde{V}_s$ ) of the given system. The source strength is determined as follows. First the electro acoustic driver is connected to the straight pipe. Then the white noise is fed into electro acoustic driver and the sound pressure level radiated from the open end of the straight pipe is measured. Using this measured radiated sound pressure ( $\tilde{p}_2'$ ), measured source acoustic impedance ( $\tilde{Z}_s$ ), and the termination acoustic impedance ( $\tilde{Z}_r$ ), the source strength ( $\tilde{V}_s$ ) is calculated using the equation (3). The derivation and successful use of the equation (3) in detail is given by Prasad and Crocker in their published work<sup>3</sup>. The  $\tilde{A}, \tilde{B}, \tilde{C}, \tilde{D}$  given in the equation (3) are four pole parameters corresponding to straight pipe.

$$|\tilde{V}_s| = (\tilde{A}\tilde{Z}_r + \tilde{B}' + \tilde{C}'\tilde{Z}_s\tilde{Z}_r + \tilde{D}'\tilde{Z}_s) \left| \tilde{p}_2' / \left( |\tilde{Z}_s| |\tilde{Z}_r| \right) \right| \quad \text{----- (3)}$$

From equation (2) we can write,

$$|\tilde{V}_o| = |\tilde{H}(\omega)| |\tilde{V}_s| \quad \text{----- (4)}$$

we can obtain sound pressure at the duct termination which is given by,

$$|\tilde{P}_o| = |\tilde{V}_o| |\tilde{Z}_r| \quad \text{----- (5)}$$

For this work, the measured source impedance is used. The source impedance was measured using two microphone random excitation technique<sup>7</sup>. Termination acoustic impedance<sup>6</sup> used for this study is given in equations (6-8) for an unflanged with an end correction of  $L' = L + 0.6a$ .

$$R_0 = 1 + 0.01336ka - 0.59079ka^2 + 0.33576ka^3 - 0.06432ka^4 \quad \text{----- (6)}$$

$$R = -R_0 e^{((-0.6393-0.1104ka)*ka*2i)} \quad \text{----- (7)}$$

$$\tilde{Z}_r = (\rho c / s) \left( \frac{1+R}{1-R} \right) \quad \text{----- (8)}$$

Where  $a$  is the radius of the pipe,  $s$  is the cross sectional area of the pipe,  $\rho$  is density,  $c$  is speed of sound,  $k$  is wave number and  $R$  is reflection coefficient. The physical and electrical analog for calculation of source strength is shown in Fig 2 and the experimental setup used for measuring the radiated source pressure from straight pipe is shown in Fig 3. The measured normalized source impedance ( $\tilde{Z}_s$ ) used for the study is shown in Fig.4 (a) and Fig 4 (b).

The ANS simulation begins with inputting the dimensions of the duct system (lengths and radii) along with frequency resolution and range. The transfer function (equation 2) is then evaluated for the input values and converted to the time domain using the inverse Fourier transform. This impulse response is then convolved with a suitable source signal (in the case of this work a white noise) to obtain the simulated acoustic noise of the duct system. The ANS procedure is shown in the flow chart in Fig 5 and can be used for any source-duct-termination model.

## 4. RESULTS OF SIMULATION USING ANS

### 4.1. Case 1: Simulation of Straight Pipe System Using ANS

First, the radiated pressure ( $\tilde{p}'_2$ ) was measured at the tip of a straight pipe (of length 0.9m and diameter 0.035m) with random noise input as shown in Fig 6. Then the source strength ( $\tilde{V}_s$ ) is calculated using four pole parameters of the pipe, source impedance, radiated impedance and measured radiated pressure ( $\tilde{p}'_2$ ) using equation (3). Using this source strength, the transfer function ( $\tilde{H}(\omega)$ ) for a test system consisting of a straight pipe of length of 0.675m and diameter of 0.035m is calculated using equation (2). The calculated transfer function for this case is shown in Fig 7 (a), (b). An Inverse Fast Fourier Transform<sup>8</sup> (IFFT) is then performed on the calculated transfer function to obtain an impulse

response ( $\tilde{h}(t)$ ) of the system<sup>9,10</sup>. The impulse response obtained for this case is shown in Fig 7 (c). The simulated output sound in time domain for the given straight pipe system (of length 0.675m) is then obtained by appropriately convolving the random noise (same parameters used to obtain the source strength) with calculated impulse response<sup>7</sup>.

Then, the frequency domain data of simulated ANS is determined as follows. First the output volume velocity ( $\tilde{V}_o$ ) is obtained by multiplying the calculated transfer function ( $\tilde{H}(\omega)$ ) of a straight pipe system (of length 0.675m) with measured source strength ( $\tilde{V}_s$ ) using equation (4). Then the frequency domain ANS value of sound pressure level is obtained by multiplying the open ended unflanged termination impedance ( $\tilde{Z}_r$ ) with output volume velocity ( $\tilde{V}_o$ ) using equation (5). The simulated ANS data in frequency domain is then compared with experiment. The experimental set up for measuring the output sound and sound pressure level for the straight pipe duct system is shown in Fig 8. The sound and vibration suite of LabView software was used for measuring the noise spectra. The simulated Sound Pressure Level (SPL) and experimentally measured SPL in frequency domain are shown in Fig 9. It is observed from Fig 9 that although the experimentally measured SPL is in overall good agreement with the simulated SPL, there are deviations observed in resonances which is possibly due to fixed length correction effects.

#### **4.2. Case 2: Simulation of Simple Expansion Chamber System Using ANS**

The system to be simulated consists of an upstream pipe (length of 0.45m and diameter of 0.035m), a simple expansion chamber (length of 0.225m and diameter of 0.095m) and a downstream pipe (length of 0.225m and diameter of 0.035m). The procedure followed for this case is similar to that of earlier systems except four pole matrices of upstream-expansion chamber-downstream pipe are used. The calculated transfer function ( $\tilde{H}(\omega)$ ) for the simple expansion chamber duct system is shown in Fig 10 (a) and (b). The impulse response ( $h(t)$ ) of the given simple expansion chamber duct system is shown in

Fig 10(c). The simulated output sound for the given duct system is then obtained by appropriately convolving the random white noise with impulse response.

The experimental set up for measuring the output sound and sound pressure level for this case is shown in Fig 11. The simulated SPL and experimentally measured SPL are shown in Fig 12. It is observed that although the experimentally measured SPL is in overall good agreement with the simulated SPL, there are deviations observed in resonances which is possibly due to fixed length correction effects. Also for this study, the upper frequency limit of 2kHz is chosen as the frequency range of interest for automotive muffler system is below 2kHz for linear theory based on pipe dimensions used in this paper.

### 5. APPLICATION OF ANS SIMULATION FOR AUTOMOTIVE MUFFLER SYTEM

Demonstration of ANS system for automotive muffler system consists of only simple expansion chamber is shown in this section. A typical automotive exhaust system without the muffler is shown in Fig. 13. Presence of muffler in exhaust system is shown in Fig.39. *(Note: Click the WAVE1, WAVE2. file symbols on the right to listen to the sound output)*



Fig. 13: Typical exhaust system without muffler element

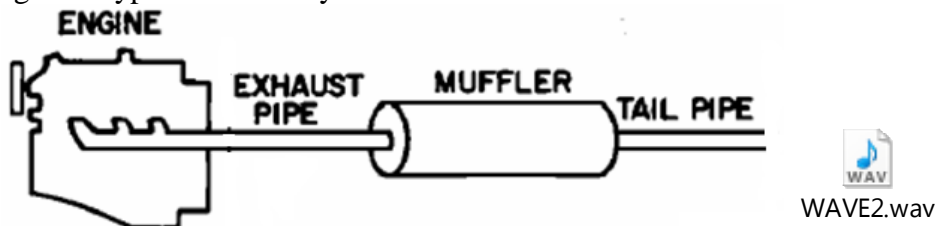
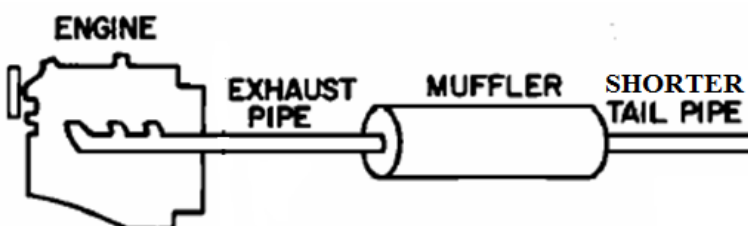


Fig 14: Typical exhaust system with muffler element to suppress the engine noise

Figure 15 and 16 shows the virtual ANS simulation of exhaust system with different tail pipe lengths. *(Note: Click the WAVE3., WAVE4. file symbols on the right to listen to the sound output)*

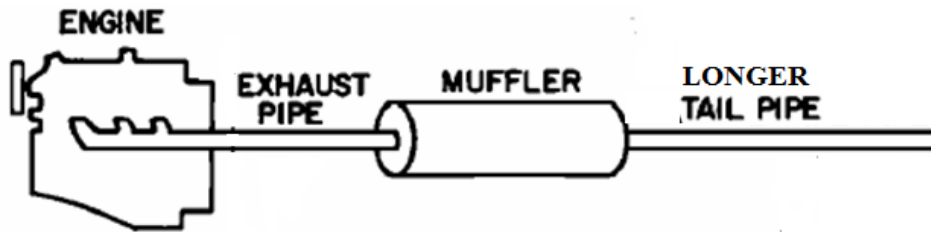






WAVE3.wav

Fig. 15: Variation of sound output due to shorter tail pipe



WAVE4.wav

Fig. 16: Variation of sound output due to longer tail pipe

This virtual ANS simulation can also be used effectively for other types of muffler systems such as reactive and dissipative types if the designers know the source impedance and geometrical parameters of the muffler systems.

## 6. CONCLUSION

The proposed Acoustic Noise Synthesis (ANS) method enables an engineer to study interactively the influence of design changes based on the simulated acoustic noise of the duct system. The ANS procedure can be applied to any complex duct system provided its transfer function or impulse response and source signal are known. The application of ANS simulation technique to the simple expansion chamber type of automotive muffler system has been demonstrated. The ANS procedure will have applications in studies related to virtual muffler design, sound quality and noise control studies of muffler or duct system before actual fabrication of the system.

## 7. REFERENCES

- <sup>1</sup>M. G. Prasad and M. J. Crocker. "Insertion Loss Studies on Models of Automotive Exhaust Systems," *J. Acoust. Soc. Am.* **70**, 1339--1343 (1981).
- <sup>2</sup>M.J. Crocker," Internal Combustion Engine Exhaust Muffling." *Noise-Con 77 Proceedings, Hampton, VA*, 331-358 (1977)
- <sup>3</sup>M.G. Prasad and Malcom J. Crocker, "A scheme to predict the sound pressure radiated from an automotive exhaust system", *J. Acoust. Soc. Am.* **70**, 1345 (1981).
- <sup>4</sup>Kitu Kumar, B Rajavel and M.G. Prasad, "Acoustic noise synthesis of muffler system", *Noise- Con 2008, Dearborn, Michigan*, July 2008.

<sup>5</sup>B Rajavel, Kitu Kumar and M.G. Prasad, “Acoustic noise synthesis of duct systems”, *Noise Control Eng. J.* **58** (5), 501-507 (2010).

<sup>6</sup>Munjal, M.L, *Acoustics of Ducts and Mufflers*, John Wiley and Sons, New York, (1987).

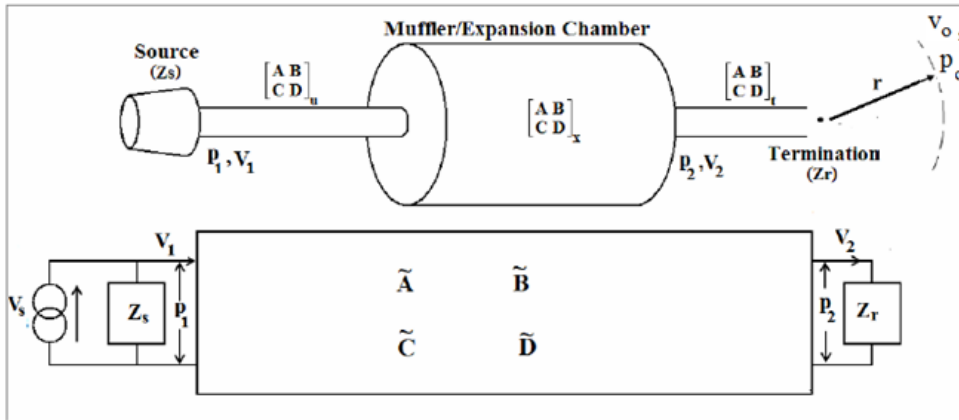
<sup>7</sup>A. F. Seybert and D. F. Ross, “Experimental determination of acoustic properties using a two-microphone random excitation technique”, *J. Acoust. Soc. Am. Volume 61, Issue 5*, pp. 1362-1370 (May 1977).

<sup>8</sup>Matlab Reference Manual, [www.mathworks.com](http://www.mathworks.com).

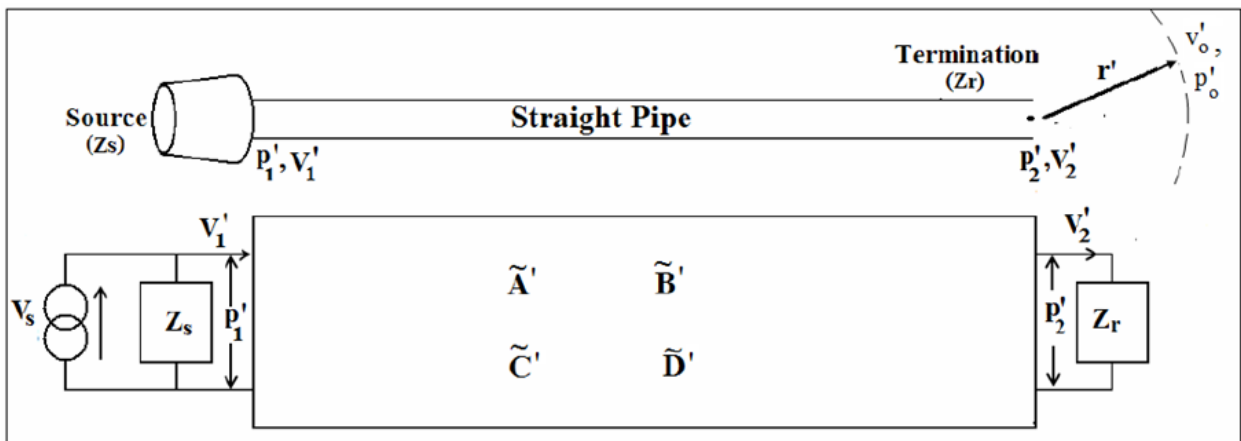
<sup>9</sup>Sanjit K Misra, *Digital Signal processing: A Computer based approach*, 3<sup>rd</sup> edition, McGraw –Hill publication, New York, (1987).

<sup>10</sup>Alan V. Oppenheim, Ronald W. Schaffer and John R. Buck, *Discrete-Time Signal Processing* 2nd Edition, Prentice Hall, (February 15, 1999).

<sup>11</sup>Lab View: Sound and Vibration Suite Reference Manual, [www.ni.com](http://www.ni.com)

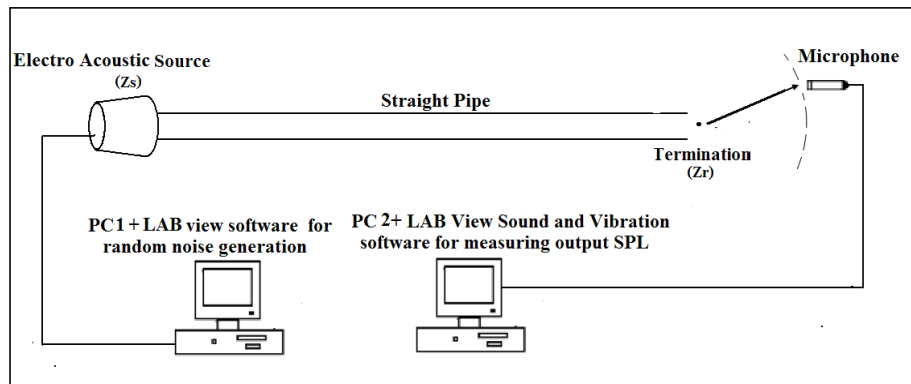


**FIG 1:** Physical and electrical analog of simple expansion chamber duct system model used for ANS

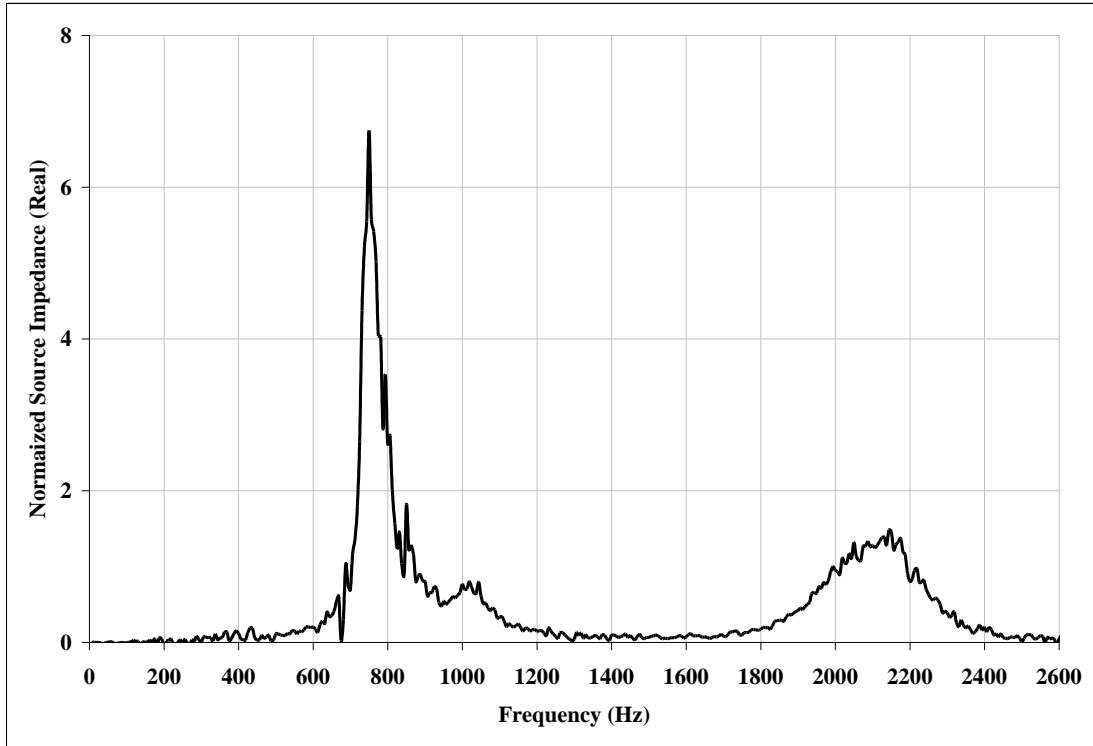


study

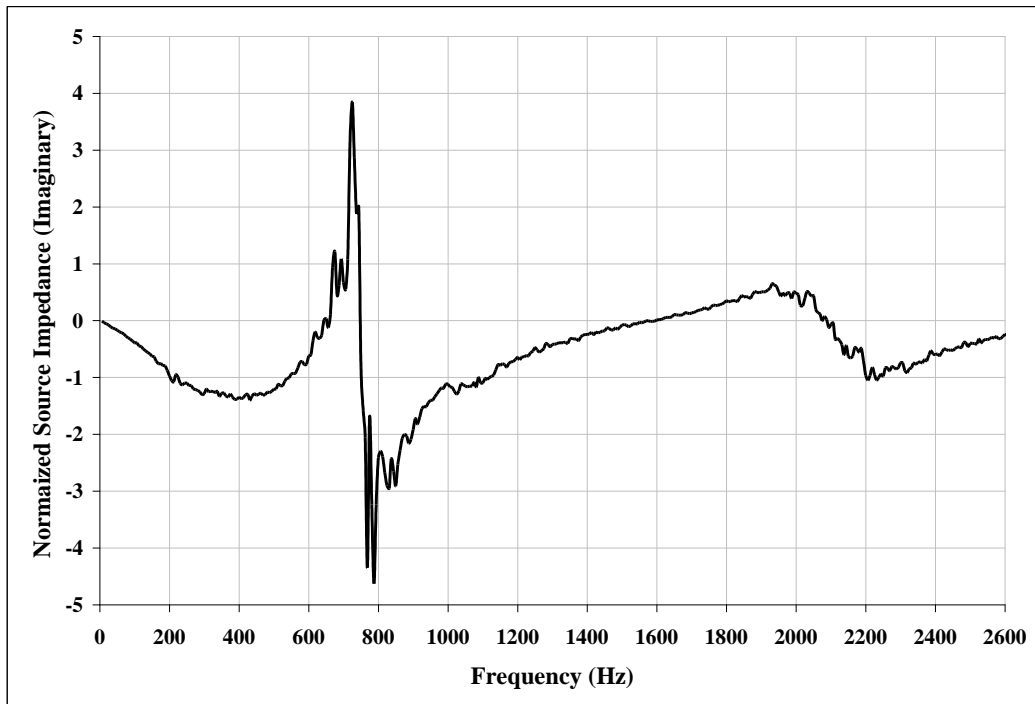
**FIG 2:** Physical and electrical analog of source strength calculation model



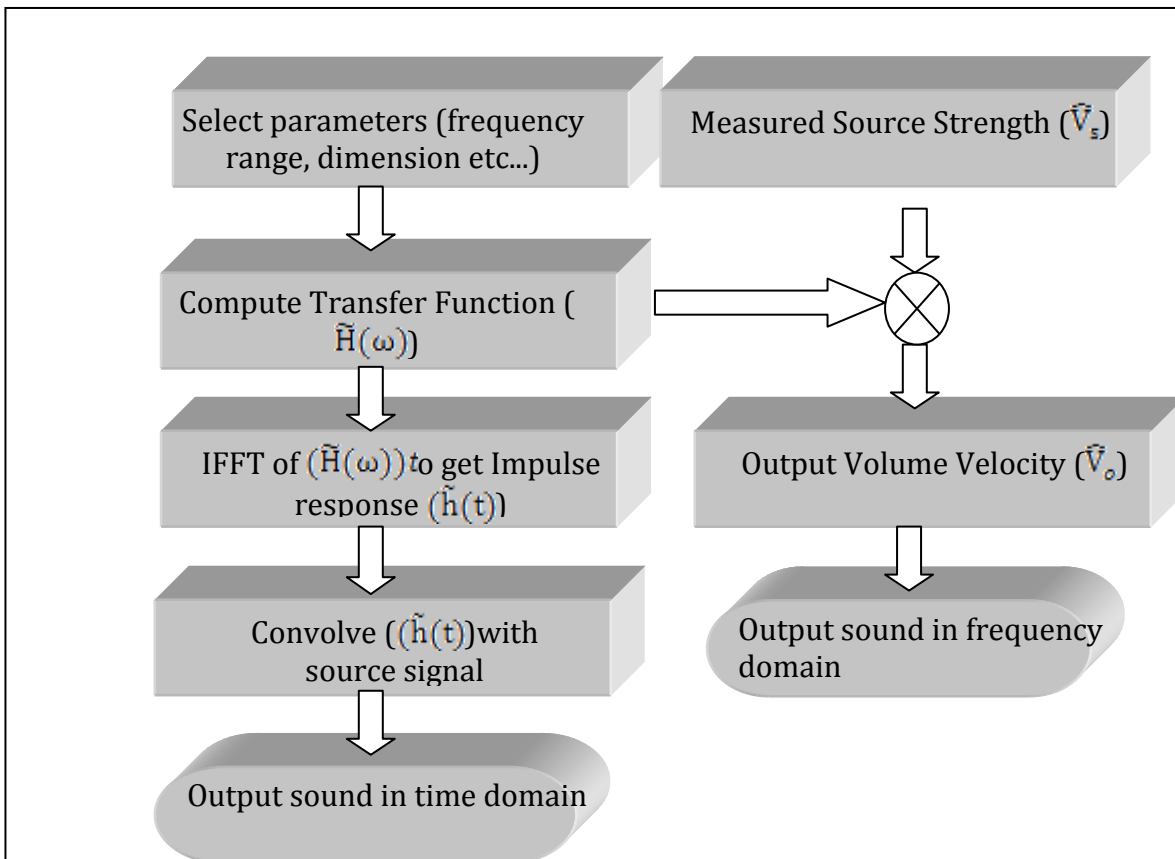
**FIG 3:** Experimental set up for measuring radiated SPL from straight pipe system for source strength calculation



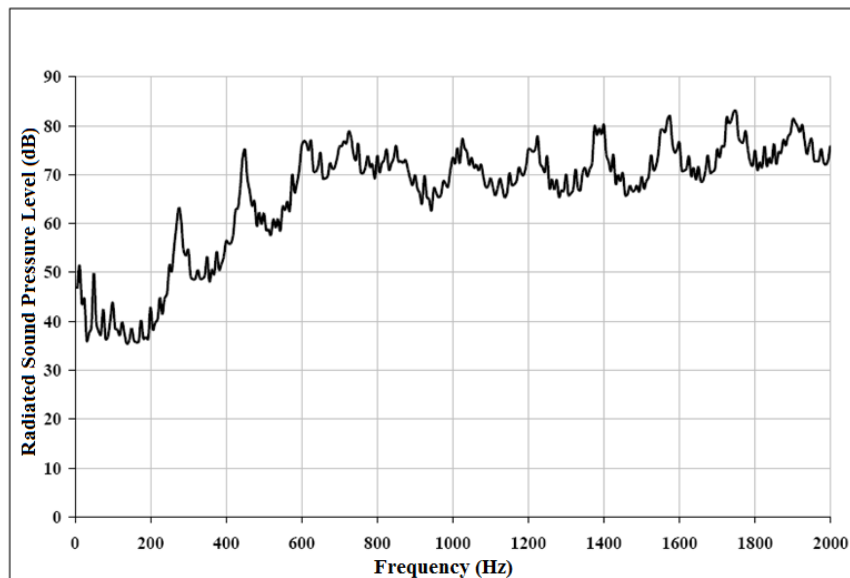
**FIG 4 (a):** Measured source impedance (Real part)



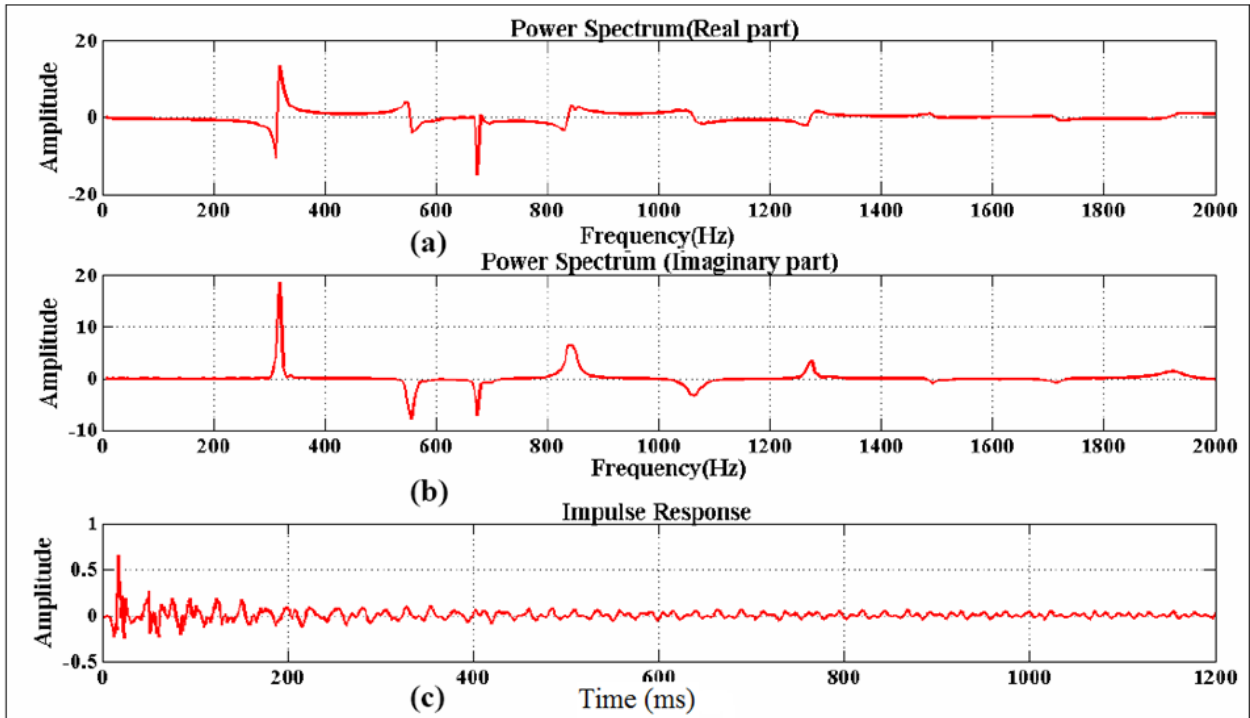
**FIG 4 (b):** Measured source impedance (Imaginary part)



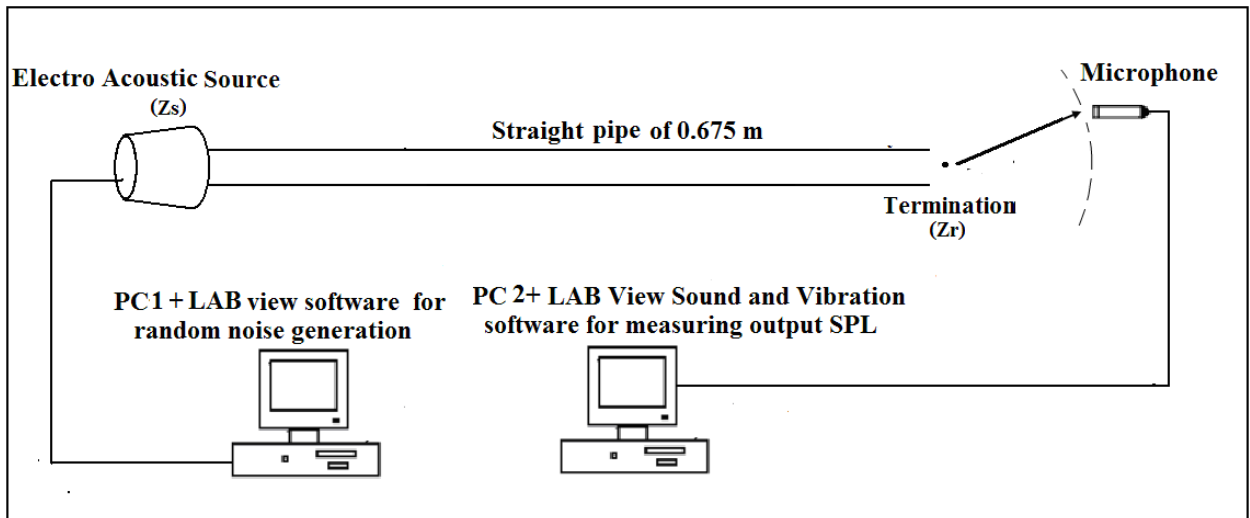
**FIG 5:** Flow Chart for Acoustic Noise Synthesis



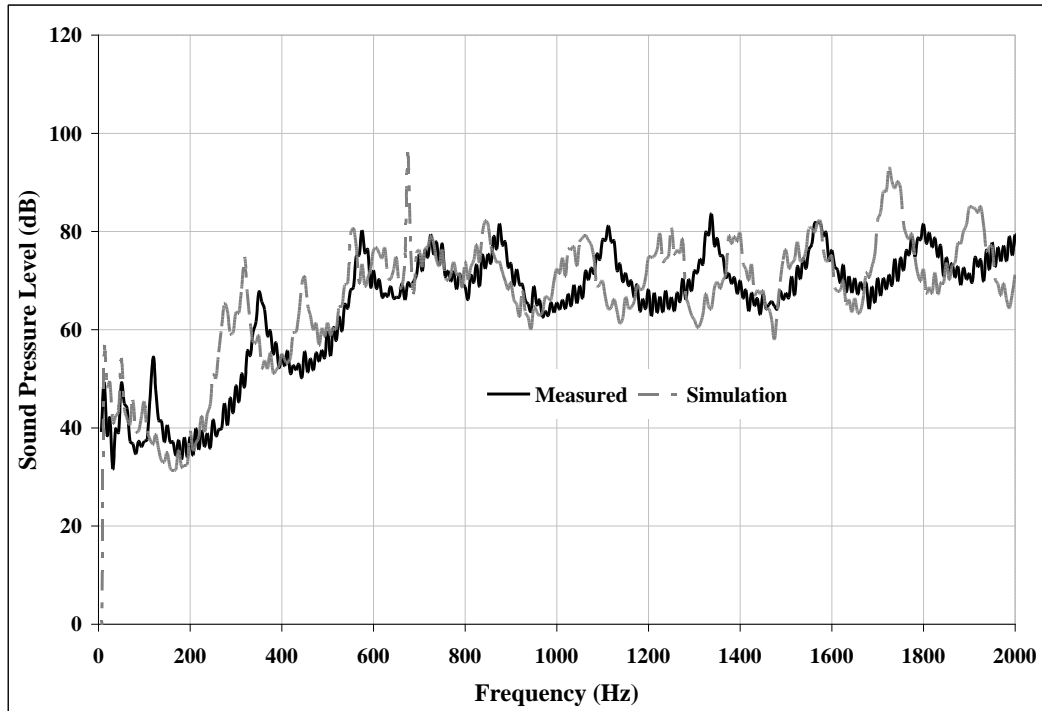
**FIG 6:** Measured source pressure of a electro acoustic driver using straight pipe system (of length 0.9m and diameter of 0.035m)



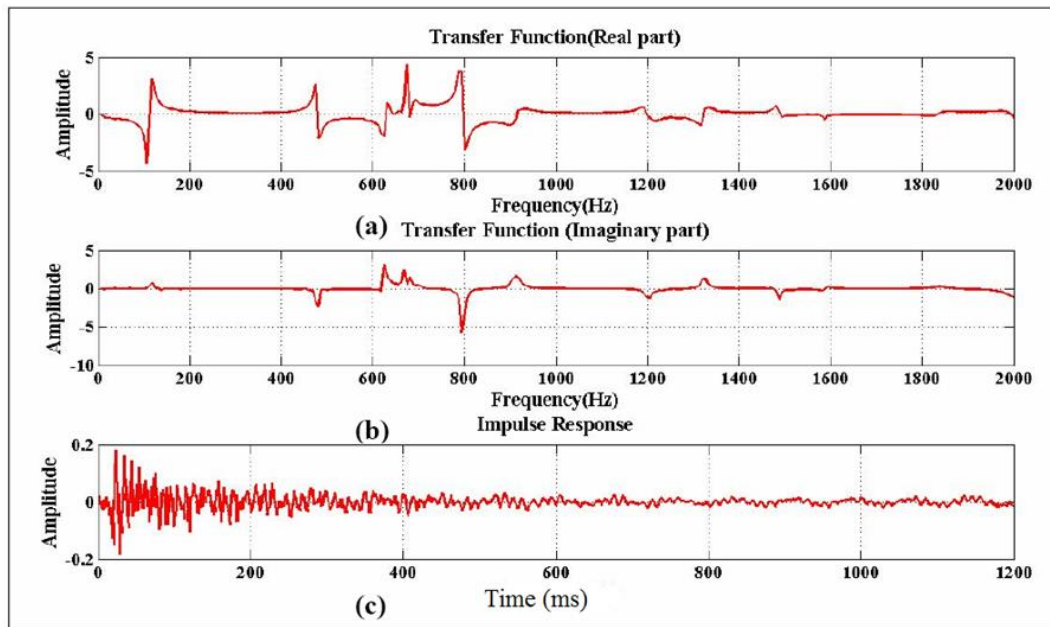
**FIG 7:** Transfer function and impulse response of an ANS model of a straight pipe system



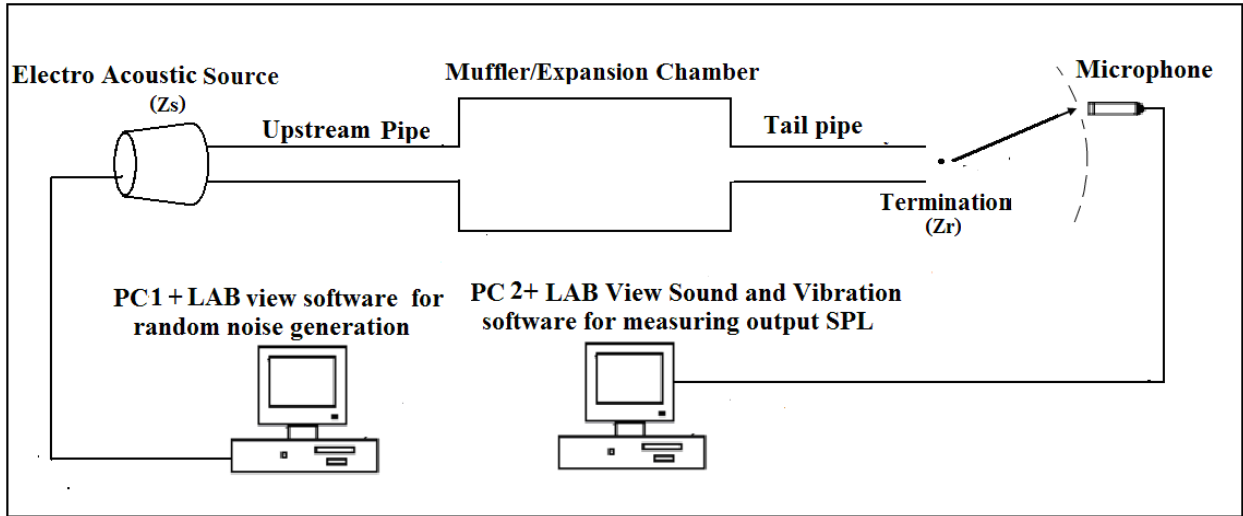
**FIG 8:** Experimental set up for measuring radiated SPL from a straight pipe system for ANS study



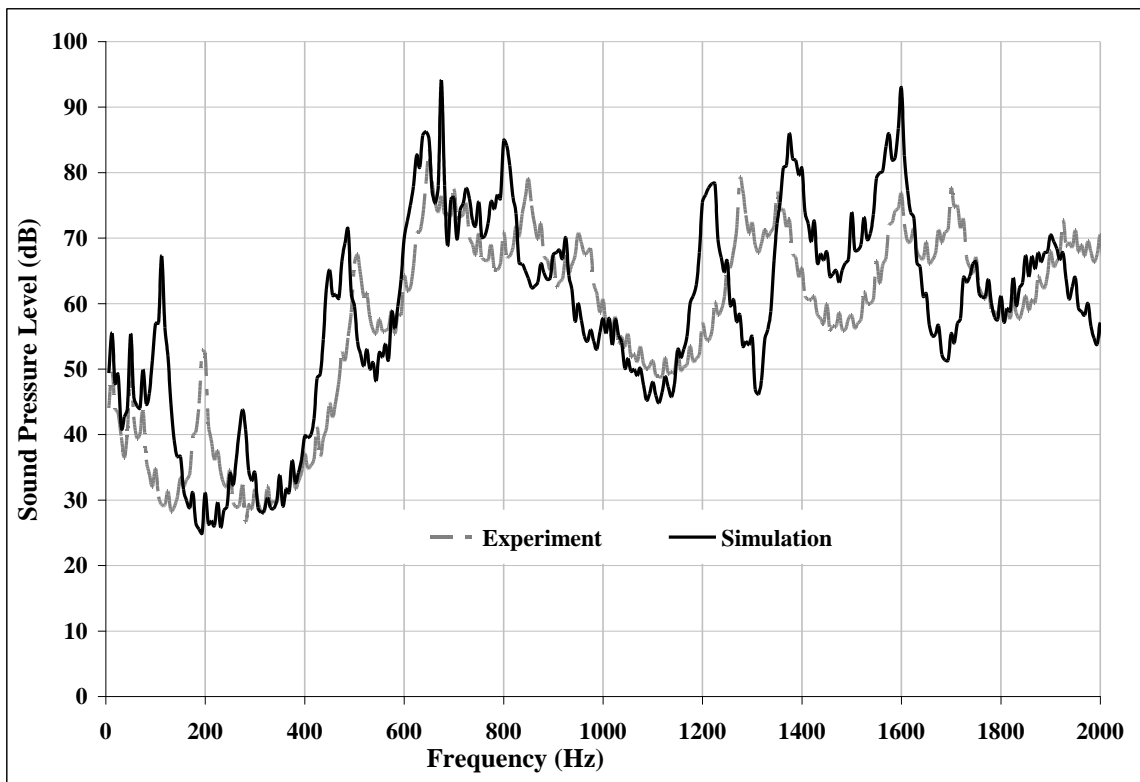
**FIG 9:** Measured and simulated sound output for straight pipe system  
(of length 0.675m and diameter of 0.035m)



**FIG 10:** Transfer Function and impulse response of an ANS for a simple expansion chamber system model



**FIG 11:** Experimental set up for measuring radiated SPL from exhaust-simple expansion chamber -tail pipe system model for ANS study



**FIG 12:** Measured and simulated sound output for simple expansion chamber system model



**Photovoltaic System Optimization through Undergraduate Engineering Clinics**

Daniel Schmalzel,  
Rowan University,  
New Jersey, USA

## **Photovoltaic System Optimization through Undergraduate Engineering Clinics Daniel Schmalzel, Rowan University, New Jersey, USA**

### **Abstract**

At Rowan University students have been introduced to Photovoltaic System Design, through the Clinic Experience, at both the residential and commercial scale. The Clinic is a project based learning approach based on the Medical School Model [1]. These experiences have included the initial feasibility assessments and continued all the way to system installation, and now include the oversight of operation and maintenance of multiple systems. Rowan University is located in the state with the second highest number of installed Photovoltaic modules in the country and still short of its 2021 goal of 2.12 percent of energy from solar PV[2]. With this installed goal far away, but completion deadline rapidly approaching, the answer may lie in large solar farms. The challenge put forth to Undergraduate Clinic Students this fall is how to optimize Photovoltaic System Designs. Where other undergraduate students are learning the basics of PV, Rowan University Students have potentially had multiple years of experience with PV and are now ready to answer the questions that will shape the future of the industry. Areas of work this semester include, but are not limited to, novel racking design, increased by-pass diode implementation to reduce the effects of shading, and possible novel ballasting systems to lower installation costs and reduce work related injuries. This diverse and broad ranging project will be tackled by an equally diverse team of engineers from all four of the College of Engineering's Disciplines (Chemical, Civil and Environmental, Electrical and Computer, and Mechanical).

### **Clinic Description**

At Rowan University every undergraduate engineering student is required to participate in four years of the Engineering Clinic. This educational approach borrows from the Medical School Model, where students spend the early part of their education in a structured classroom environment learning the fundamentals of their discipline. Once a solid medical, or in this case engineering, foundation has been laid students are ready to put their knowledge to use. The concept of applying knowledge learned in the classroom is by no means unique, but Rowan University's uniqueness is the stage at which these applications of engineering fundamentals are applied. Many engineering curricula culminate in a Senior Design during the final semester, or possibly beginning in the fall of the senior year, and ending in the spring with the final report. By the final year of a student's education only a fraction of the many lessons possibly gained from such a project are achieved. By this time a student has taken to many regimented classes which result in a sluggish ability to draw on that knowledge when finally given a unique problem. The next issue with such a late Design Project is the student may be already looking beyond school at employment possibilities, after years in a classroom the doer personality of many engineering students just want to start doing! The Senior Design Project is not without some educational merit, it does represent the first time the engineering student may do something that more accurately represents what an engineer does.

### **Clinic Advantage**

Where Rowan University differs substantially is their implementation of this "Design Project", or The Clinic, at the beginning of the junior year. Exposure to a "Real Project" at this point allows a student to see multiple projects instead of just one for a semester during their undergraduate degree. It also allows the individual to develop their professional identity, as well as a portfolio of project experience, prior to graduation. These two qualities are unique to Rowan University Graduates, which allow them to easily differentiate themselves from other degree holders, from other engineering schools. In this competitive job market it is no longer enough to just have a strong collection of course work. Candidates must also be able to show a track record of project

experience and success. Which, without the clinic, may mean a graduate would have to work one or multi jobs before getting the most competitive one.

**Clinic Structure**

We have established that the clinic exposes students to projects in the junior year, but to truly be like the Medical School Model, it also has to cover additional fundamentals. Table 1 summarizes the eight semesters of the clinic experience, along with a short description of each of the core concepts covered through the semester.

**Table 1** – The Engineering Clinic Experience at Rowan University <sup>[1]</sup>

|           | Fall Semester                              | Spring Semester                            |
|-----------|--------------------------------------------|--------------------------------------------|
| Freshman  | FEC I<br>Measurements                      | FEC II<br>Reverse<br>Engineering           |
| Sophomore | SEC I<br>Design w/written<br>communication | SEC II<br>Design w/oral<br>communication   |
| Junior    | JEC I<br>Sponsored Design<br>or Research   | JEC II<br>Sponsored Design<br>or Research  |
| Senior    | SrEC I<br>Sponsored Design<br>or Research  | SrEC II<br>Sponsored Design<br>or Research |

**Freshman Engineering Clinics (FEC I and FEC II)**

As freshman, regardless of discipline, students are introduced to basic concepts that apply to all engineers. Students work on projects that address engineering measurement and reverse engineering. An exemplar task would be to perform systematic testing of existing products with the goal of possibly illuminating areas for improvement [3]. During this year students are also lectured on professionalism and engineering ethics <sup>[4]</sup>

**Sophomore Engineering Clinics (SEC I and SEC II)**

By the second year students have an understanding of the basic composition of an engineer; their next area of development is communication. The first semester focuses on written communication, while the second emphasizes oral communication. During both of these clinics the engineering student takes a separate course that teaches the fundamentals of each communication type, a writing/literature course to teach writing and a public speaking course to complement the second clinic. All teams in a specific Clinic will be given the same well defined problem statement that is the subject of the entire semester. The individual student’s grade will be based on their performance in both team and individual presentations or writings. At the end of this year students should understand that an engineer maybe called to act as project interpreter and advocate. So their ability to accurately convey knowledge with many different audiences may be directly correlated to their later career success. It is also at this stage that students work in their first inter-disciplinary team, a hallmark of the Rowan Clinic Experience.

**Junior and Senior Engineering Clinics (JEC I, JEC II, SrEC I and SrEC II)**

Once an upper classman, the student is prepared for full exposure to the most challenging Clinic Projects. At this level the Clinic team receives an open ended problem where the solution is not immediately apparent nor is it well defined. Topics address professor research interests and are often funded from external sources, such as State and Federal Government Agencies but many industrial partnerships have been created through the clinic as well. The process of project

selection is also unique, because it relies on a mutual selection process. On the first Tuesday of the semester the Faculty member or Graduate Student, leading the project, presents the project to each engineering discipline at the school (CEE, ChE, ECE & ME). Each engineering discipline stays in a specific room though the process, and receives a slightly different project summary from the presenter. The faculty member or graduate student makes sure to showcase that disciplines potential impact area. Once the presentations are completed each student is required to rank their top three choices based on what they have just seen. It is not uncommon for students to stay intra-disciplinary, but each student is required to take a minimum of one out of discipline clinic. This requirement at times creates a level of disappointment or uneasiness, but can quickly lead to the discovery on an unknown passion. Once all of the selection sheets are submitted a panel of professors makes the final team lists, and by noon on Thursday the teams are announced, and students are to report to their first clinic meeting. Although it may seem chaotic when described it is actually very well orchestrated and serves as a good view into the pace at which project teams may be assembled. This pace and limited initial knowledge introduces them to another vital skill in engineering, confidence. Often the student will have to confidently make decisions after a relatively short learning curve.

#### Rowan University’s Center for Sustainable Design (CSD) Description

At Rowan University, a number of sustainably focused clinics and projects are regularly offered from The Center for Sustainable Design (CSD). The CSD has laboratory space at the Samuel H. Jones Innovation Center, also known as the South Jersey Technology Park. More importantly than its research facility and space, is the CSD professor make up. With professor involvement from all four disciplines of engineering and across various colleges of the university, we are able to consistently offer a diverse suite of sustainably focused projects from numerous funding sources. The CSD’s Mission Statement, as it appears on their website is:

*To actively engage faculty, graduate students and undergraduate students in research and project based learning that will advance the technology readiness and adoption of sustainable energy systems and address the challenges of:*

- *Achieving Grid Parity for Renewable Energies*
- *Combating Climate Change through:*
  - Efficiency, Conservation, Increased Asset Utilization*
- *Creating New Technologies for the Smart Grid*
- *Building the Business Case for Sustainability*

#### Rowan University’s Center for Sustainable Design (CSD) PV Project List

It is through this passion and collection of professors that Rowan University students have had numerous experiences with photovoltaics in both the classroom and the laboratory. This extensive exposure to such an emerging technology is beneficial educationally and occupationally. Below is a table that highlights the various forms photovoltaics have been presented to students over the last six years.

**Table 2. - Exemplar Photovoltaic System Clinic Design Projects [1]**

| <i>Year</i> | <i>Exemplar Photovoltaic System Design Projects</i>                                                                                                                                                                                                                                                                                                      |
|-------------|----------------------------------------------------------------------------------------------------------------------------------------------------------------------------------------------------------------------------------------------------------------------------------------------------------------------------------------------------------|
| <b>2011</b> | <i>Freshman Clinic PV System Design Laboratory (Spring 2011)</i><br><i>Sophomore Clinic PV System Design Experience (Spring 2011)</i><br><i>1.65 kW Photovoltaic (PV) System Permitting &amp; Construction Rowan Hall (Kaneka)</i><br><i>10 MW Photovoltaic (PV) System, Rowan University (Internal)</i><br><i>PV Module shading analysis (internal)</i> |

|             |                                                                                                                                                                                                                                                                |
|-------------|----------------------------------------------------------------------------------------------------------------------------------------------------------------------------------------------------------------------------------------------------------------|
| <b>2010</b> | <i>1.65 kW PV System Design &amp; Siting Rowan Hall (Kaneka - Japan)<br/>10 MW Photovoltaic (PV) System, Rowan University (Internal)<br/>PV Module shading analysis (internal)</i>                                                                             |
| <b>2009</b> | <i>12 kW Photovoltaic (PV) System SJTP (SunTechnics)<br/>PV System Design for NJDMAVA Headquarters<br/>PV System Design for W.J. Doyle Veterans Cemetery</i>                                                                                                   |
| <b>2008</b> | <i>3 MW Photovoltaic Power Plant, Falls Twp., PA (SunTechnics)<br/>1 kW Photovoltaic (PV) System Installation - SJTP (Kaneka Solar)</i>                                                                                                                        |
| <b>2007</b> | <i>3 MW Photovoltaic Power Plant, Falls Twp., PA (SunTechnics)<br/>Design of PV Systems for Municipal and School Buildings (Ocean City)<br/>1 kW PV System Design &amp; Siting (Kaneka Solar)<br/>Performance Monitoring and Data Analysis (RU Team House)</i> |
| <b>2006</b> | <i>3-kW PV System Construction RU Team House (Internal)</i>                                                                                                                                                                                                    |
| <b>2005</b> | <i>Design and Siting of 3-kW PV System at Rowan University (Internal)</i>                                                                                                                                                                                      |

### Clinic Team Challenge

With the many projects already offered at various stages in a student's education some upper level students have multiple years of experience with the technology. This both forces, and allows, the faculty to move away from the basics of the technology to addressing the "real issues" of the industry. One such opportunity to address real issues stems from the CSD's repeated cooperation with a major area Solar Installer. The University is in the final stages of finalizing an agreement that will fund research into some of the immediate and future issues of their industry. Students in the ECE-11 photovoltaic system optimization clinic will work on novel designs for both racking and a ballasting alternative. Unfortunately, at the time this paper was written the students were only a quarter of the way into the semester and still in the research phase of the process, so progress on these tasks is minimal.

In this clinic, students are presented with a specific open ended project, but the potential solutions are vast. Since the students now work in interdisciplinary groups outside the traditional confines of a classroom, they are allowed to take a more individualized approach, however they generally go as follows. Upon forming the 2-5 student team, projects start out with an information search and review, followed by development of a clear and concise problem statement. From that point students research and design solutions to the problem and develop methods for down selecting alternatives, prototyping, testing, documentation, etc [3]. During the semester, students for the most part work independently. Meetings are kept to a minimum, in order to preserve as much of the scheduled Clinic time (3 hour blocks, twice weekly) for project work. At the end of the semester, all the teams that have worked and met independently, will come back together for a final required presentation of their work to a collection of their peers, graduate students and faculty.

When compared to traditional educational approaches, students have significant autonomy, yet teams still receive guidance from a professor and often a graduate student as well. For the second semester in a row, the CSD has four funded graduate students to oversee four different projects. The primary role of the Graduate Student is to help with the day-to-day project management functions in coordination with the faculty principal investigator. Graduate Student involvement in upper level Clinics is not a requirement, but their presence ensures a smoother functioning team and gives the graduate student opportunities to develop project management skills and experience

directing a team to achieve well-defined goals within constraints. Undergraduate students benefit from working with Graduate students because fresh graduates are able to relate well to the challenges the Undergraduate students are facing.

#### By-Pass Diode/ Module Design

In a PV cell, electric generation is proportionally related to the amount of sunlight that reaches the surface of a solar cell and to the area of the cells in a module. Solar cells are typically connected in series to achieve a voltage target—e.g., a nominal 450 VDC string. The disadvantage of this configuration is that an interruption to a single cell in the series can result in the disruption of flow through the entire array. A PV cell is fundamentally a diode; when the diode is illuminated with sunlight, the PV cell becomes forward biased; on the contrary, when the light path is blocked via shadow or other obstruction, the cell becomes reverse biased <sup>[5]</sup>. What is unknown by most practitioners is just how significant an impact shading presents. Not only does shading negatively affect power output of the PV module, it can also potentially damage individual cells <sup>[5]</sup>. PV module manufacturers often include bypass diodes as one means of effectively bypassing shaded cells. Bypass diodes can also protect shaded PV cells from destructive reverse voltage. Even though they may increase manufacturing costs their potential positive impact outweighs the financial negatives. Studies conducted at the CSD have shown that the bypass diodes may be ineffective depending on the orientation of the module and the geometry of the shadow cast on the module's surface.

One of the challenges put forth to the clinic team this fall is the design of a more robust photovoltaic module. Students are responsible for the analysis and design of different PV module architectures with diverse bypass diode configurations. These modules will be modeled using appropriate design software, in this case PSpice. Once analyzed and optimized, a prototype PV module will be fabricated then tested in both real world and laboratory settings. Collaboration between students from Rowan University and Bucknell University will perform the tests.

#### Novel Racking Design

An additional topic for one of our fall clinic teams is the design of a novel racking system. Over the last ten years, the cost of installing solar has decreased by more than 50%, going from over \$10 to about \$5 /watt <sup>[6]</sup>. As module technology continues to innovate and prices continue to decrease, there is pressure to innovate on the balance of system (BOS) costs. The physical mounting system—termed “racking”—is one area that has potential for cost reduction. Students will perform a study of existing racking options available to determine strengths and weaknesses. Completing this study will illuminate opportunities for improvements based on material selection, fabrication, installation, power density, and other details that contribute to total cost. Students will complete a design based on the study results and then develop a prototype for testing. Construction will allow them to take the project from concept to full size physical model.

#### Novel Ballast Design

The final area for potential work this fall is the development of a novel ballasting option. When anchoring a system in cases where roof or ground penetration is not feasible, alternative means are required. Ballasting refers to the process of weighting the solar rack system to provide sufficient force to exceed anticipated wind loads. The amount of ballasting required is determined through an analytic assessment of the mass required to counteract the systems potential uplift. In a ground mounted system, perhaps installed over a closed landfill where penetrating the cap is a concern, large concrete blocks are often the preferred method of providing ballast. These large blocks can be easily positioned and placed with machinery. However, for a roof top system, many small concrete blocks are typically used to supply the necessary mass. The conveyance of the required block becomes an obstacle and poses risks of injury to the workers that must transfer and place the

ballast. Students will be working on devising a system that offers an equivalent mass while minimizing the potential risk to workers.

## References

1. C.D. Barreiro, P.M. Jansson, D. Schmalzel, "Educating Engineers through Undergraduate Engineering Clinics". 2011 ICEE Annual Conference. August 2011.
2. <http://www.statesadvancingsolar.org/program-guides/new-jerseys-clean-energy-program>. Accessed September 2011.
3. D. Schmalzel, "10 Megawatts to a Better Education". ASEE Middle Atlantic Spring 2011 Conference. April 2011.
4. P.M. Jansson, W. Riddell, J. Everett, "*Teaching Sustainable Design via Experiential Learning*," International Journal of Technology, Knowledge and Society, Vol. 4, Issue 3 (2008).
5. C. Barreiro, P.M. Jansson, A. Thompson, J.L. Schmalzel, "Photovoltaic Module By-Pass Diode Performance in Landscape and Portrait Modalities". 37<sup>th</sup> IEEE PV Specialists Conference. June 2011.
6. [http://www.ases.org/index.php?option=com\\_content&view=article&id=1356&Itemid=23](http://www.ases.org/index.php?option=com_content&view=article&id=1356&Itemid=23). Accessed September 2011.

**Development of a dual-receptor targeted drug  
delivery system for treating vascular disease**

Thelma Chuene  
Department of Mechanical Engineering  
Temple University,  
Philadelphia, PA 19122

Giuseppina Lamberti  
Department of Mechanical Engineering  
Temple University,  
Philadelphia, PA 19122

Mohammad F. Kiani  
Department of Mechanical Engineering  
Temple University,  
Philadelphia, PA 19122

Bin Wang  
Department of Mechanical Engineering  
Temple University,  
Philadelphia, PA 19122



## Development of a dual-receptor targeted drug delivery system for treating vascular disease

Thelma Chuene, Giuseppina Lamberti, Mohammad F. Kiani, Bin Wang

Department of Mechanical Engineering  
Temple University, Philadelphia, PA 19122

**Introduction.** Drug delivery systems targeted to the vasculature provide an effective mean for increasing the therapeutic efficiency of various drugs and reducing the side effects as well as the frequency of the dosages taken by the patient. Studies have shown that two-receptor targeted drug carriers have higher efficiency in binding and delivery of therapeutic agents to the targeted tissue in comparison with single-receptor targeting approaches. In the past, antibody coated fluorescent microspheres have been widely used as a model leukocyte to mimic leukocytes adhesion cascade. In this study we present a novel dual-receptor (selectins and ICAMs) targeting approach to enhance the drug carrier's binding efficiency to the inflamed tissue in endothelial wall.

**Methods.** Dual-receptor targeted model drug carriers (florescent microspheres) were prepared by coating the microspheres with different ratios of antibodies against ICAM-1 ( $\alpha$ ICAM-1) and E-selectin ( $\alpha$ E-selectin). The ratio of antibodies attached on the microspheres was quantified by fluorescence intensities using the Nikon Software and a Nikon Eclipse TE200 inverted microscope equipped with a fluorescence illumination system. The level of adhesion of the microspheres on HUVEC was quantified by counting the number of adherent microspheres on HUVEC using a fluorescent light microscope. Differences in the level of firm adhesion of microspheres with different ratios of  $\alpha$ ICAM-1/ $\alpha$ E-selectin were examined under different flow condition.

**Results.** Microspheres coated with different ratios of antibodies ( $\alpha$ ICAM/ $\alpha$ E-selectin = 30/70, 50/50 or 70/30) were prepared and tested under flow. Our findings indicate that microspheres coated with 50/50 ratio of  $\alpha$ ICAM-1 and  $\alpha$ E-selectin have the highest binding efficiency compared to the single antibody coated microspheres. The number of  $\alpha$ ICAM-1+ $\alpha$ E-selectin microspheres bound to HUVECs appeared to decrease with increase in wall shear stress in the flow chamber. Moreover, the number of adherent  $\alpha$ ICAM-1+ $\alpha$ E-selectin microspheres was significantly higher than the adherent  $\alpha$ E-selectin microspheres under different flow conditions. In particular, the level of firm adhesion of the dual-receptor targeting microspheres was 1.1 times than  $\alpha$ E-selectin microspheres at wall shear stress of 0.5 dynes/cm<sup>2</sup>; 2.3 times at 2 dynes/cm<sup>2</sup>; and 3.4 times at 4 dynes/cm<sup>2</sup>.

**Conclusions.** We have designed a two-receptor targeted drug delivery carrier that recognize endothelial expressed inflammation markers, selectin and ICAM, for the purpose of targeting inflammation in vivo. We conclude that the adhesion efficiency of the two-receptor targeting microspheres is significantly higher than the single-ligand microspheres under various flow conditions and that the drug carrier adhesion ability can be optimized by optimizing the ratio of the two ligands on the surface of the microsphere. Therefore a novel dual-receptor targeted drug delivery system may be developed to achieve higher targeting efficiency and effectiveness in therapeutic treatment of vascular diseases.

## **Unconventional Nanopatterning Techniques for Gold Nanostructures**

Chris Decker  
Department of Mechanical Engineering,  
Temple University,  
Philadelphia, PA 19122

Aarthi Sundar  
Department of Mechanical Engineering,  
Temple University,  
Philadelphia, PA 19122

Robert Hughes  
Department of Mechanical Engineering,  
Temple University,  
Philadelphia, PA 19122

Svetlana Neretina  
Department of Mechanical Engineering,  
Temple University,  
Philadelphia, PA 19122

## Unconventional Nanopatterning Techniques for Gold Nanostructures

*Chris Decker, Aarthi Sundar, Robert Hughes and Svetlana Neretina*

Department of Mechanical Engineering, Temple University, Philadelphia, PA 19122

The fabrication of periodic arrays of noble metal nanostructures immobilized on a substrate surface are of technological relevance to numerous applications including photovoltaics, seeded nanowire synthesis, waveguides, catalysis, chemical and biological detection, enhancement agents for light emitting diodes and the fabrication of metamaterials. Presently, such arrays are obtained using lithographic fabrication routes which are technically demanding and cost-prohibitive. Recently, numerous unconventional nanopatterning techniques have emerged which are cost-effective, but these techniques have been predominantly directed toward polymer materials where low processing temperatures are the norm. The development of similar routes for metals, where processing temperatures are considerably higher, has proved more challenging. The most straightforward method for obtaining substrate-based gold nanostructures is through the room temperature deposition of a continuous ultrathin gold film followed by its subsequent agglomeration at elevated temperatures. The main drawbacks of this thermal dewetting procedure are the substantial nanoparticle size distributions realized and the lack of control over nanostructure placement. Unconventional nanopatterning techniques directed toward polymer films have also demonstrated the utility of manipulating the dewetting phenomenon from the free surface of the film. In an analogous manner, three methodologies have been developed to test the viability of first depositing a thin gold film and then creating weak points in the film using mechanical means in an effort to activate the dewetting phenomenon such that film agglomeration occurs at predefined locations. The first approach utilizes a nano-indenter with a GS0-10 Load Cell and a 5  $\mu\text{m}$  radius carbide tip, the second utilizes a micron-scale rigiflex mold applied to the surface using a Tinius Olsen 10000 electromechanical compression testing instrument, and the third uses an embossing technique to create a template for activating the dewetting through capillary forces. The gold patterns formed will be presented and the viability of advancing these methodologies towards a cost-effective bench-top process for forming arrays of metal nanoparticles will be discussed.

## **The Mechanics of PEM Fuel Cell Stack Compression**

Bryan Dallas  
Composites Laboratory  
Department of Mechanical Engineering  
Temple University

Parsaoran Hutapea  
Composites Laboratory  
Department of Mechanical Engineering  
Temple University

## The Mechanics of PEM Fuel Cell Stack Compression

Bryan Dallas and Parsaoran Hutapea

Composites Laboratory

Department of Mechanical Engineering

Temple University

The decreasing performance of proton exchange membrane (PEM) fuel cells can be caused by changes in stack clamping pressure (i.e., compression). When the stack is compressed, the membrane electrode assembly (MEA) typically deforms 50 to 200 nm. Lee et al (Journal of Power Sources, 84, 45-51, 1999) discusses that this nanoscale deformation causes changes to the porosity of the gas diffusion layer (GDL) which, in turn, alters the permeability and diffusion of the reactant gas and the transport of the liquid water in the MEA. However, the deformation also decreases electrical contact resistance, which suggests there is an optimization of how much the MEA should deform. The focus of the project is to assess the effects of compression and GDL nano-deformation on fuel cell performance. A testing system was constructed such that the stack compression can be altered without disassembling it. This is facilitated by a cell equipped with a compression plate with a compression adjuster and a dial gauge to measure the change in thickness of the MEA. This feature is essential since a cell's performance is altered considerably if it is disassembled and then reassembled, even if the clamping conditions are accurately reproduced. The fuel cell performance will be tested at different deformations and compared.

---

<sup>1</sup> Frank Oppenheimer

<sup>2</sup> Eric Mazur, Harvard University, <http://mazur.harvard.edu/>

<sup>3</sup> Elliot Aronson, University of Texas and University of California, <http://www.jigsaw.org/>

<sup>4</sup> Thielens, W., "The Disciplines and Undergraduate Lecturing," paper presented at an annual meeting of the American Educational Research Association, April 1987, Washington, DC, ED 286 436, 57 pp, MF-01, PC-03.

<sup>5</sup> Chickering, A. and Z. Gammons, "Seven Principles for Good Practice," *AAHE Bulletin*, 39: 3-7, March 1987, ED 282 491, p.6.

<sup>6</sup> Gangwer, Timothy, *Visual Impact, Visual Teaching: Using Images to Strengthen Learning*, Sage Pub, 2009

<sup>7</sup> Felder, R.M., and R. Brent, "Death by PowerPoint," *Chem. Engr. Education*, **39**(1), 28 (2005)  
[www.ncsu.edu/felder-public/Columns/PowerPoint.pdf](http://www.ncsu.edu/felder-public/Columns/PowerPoint.pdf)

<sup>8</sup> LoPiccolo, Orla, "What I See I Remember, What I Do I Understand" American Society of engineering Education, Middle Atlantic Section Fall 2010 Conference, Villanova University, PA.

<sup>9</sup> Paulson, Donald and Faust, Jennifer, Active Learning for the College Classroom,  
<http://www.calstatela.edu/dept/chem/chem2/Active/main.htm>

<sup>10</sup> Johnson, D. W., R. T. Johnson, and K. Smith, Active Learning: Cooperation in the College Classroom, Interaction Book Company, Edina, MN, 1991

<sup>11</sup> Ledlow, Susan, "Cooperative Learning in Higher Education," Center for learning and Teaching Excellence,  
<http://clte.asu.edu/active/clinhighed.pdf>

<sup>12</sup> Kohn, Alfie Kohn, "Punished by Rewards. The Trouble with Gold Stars, Incentive Plans, A's, Praise, and Other Bribes" (Boston: Houghton Mifflin, 1993 / 1999)

<sup>13</sup> Aronson, Elliot, History of Jigsaw, Social Psychology Network, <http://www.jigsaw.org/history.htm>

<sup>14</sup> Mel Silberman, Active Learning to Teach Any Subject, P 111, Allyn and Bacon 1996

<sup>15</sup> Criteria for Evaluating Engineering Technology Programs, ABET, 2011-2012  
<http://www.abet.org/Linked%20Documents-UPDATE/Criteria%20and%20PP/T001%2010-11%20TAC%20Criteria%2011-3-09.pdf>

<sup>16</sup> Prince, M., "Does Active Learning Work? A Review of the Research," *J. Engr. Education*, **93**(3), 223 (2004)

---

[www.ncsu.edu/felder-public/Papers/Prince\\_AL.pdf](http://www.ncsu.edu/felder-public/Papers/Prince_AL.pdf)

<sup>17</sup> Dietrich, Suzanne W, Getting Started with Cooperative Learning in the Engineering Classroom  
<http://clte.asu.edu/active/mainart.htm>

<sup>xviii</sup> Slavin, R.E., "Cooperative learning: Theory, research, and practice" 1995, (2nd Ed.). Boston: Allyn & Bacon

<sup>xix</sup> Thompson, Marceline, and Pledger, Linda, "Cooperative Learning Versus traditional Lecture Format: A Preliminary Study", 1998, National Communications Association

<sup>xx</sup> Johnson, D.W., & Johnson, R.T. "Learning together and alone: Cooperative, competitive, and individualistic learning" (4th Ed.). 1994, Boston: Allyn & Bacon

<sup>xxi</sup> Rich, Y., Amir, Y., & Slavin, R.E. "Instructional strategies for improving children's cross-ethnic relations" 1986  
Ramat Gan, Israel: Bar Ilan University, Institute for the Advancement of Social Integration in the Schools